



**Economic and Social  
Council**

Distr.  
GENERAL

TRANS/WP.29/2000/58  
22 September 2000

ENGLISH ONLY

---

**ECONOMIC COMMISSION FOR EUROPE**

INLAND TRANSPORT COMMITTEE

World Forum for Harmonization of Vehicle Regulations (WP.29)  
(One-hundred-and-twenty-second session, 7-10 November 2000,  
agenda item 6.11.)

**PROPOSAL FOR DRAFT O3 SERIES OF AMENDMENTS TO REGULATION No. 49**

(Emissions of C.I., NG and P.I. (LPG) engines)

Transmitted by the Working Party on Pollution and Energy (GRPE)

Note: The text reproduced below was adopted by GRPE at its fortieth session and is transmitted to WP.29 and AC.1 for consideration. It is based on the text of documents (informal documents Nos. 8 and 14) distributed during the session without a symbol (TRANS/WP.29/GRPE/40, paras. 14-16). The proposal is intended to align Regulation No. 49 with European Community Directive 1999/96/EC.

---

This document is a working document circulated for discussion and comments. The use of this document for other purposes is the entire responsibility of the user. Documents are also available via the INTERNET:  
<http://www.unece.org/trans/main/welcwp29.htm>

Paragraph 1. footnote 1/, amend to read:

"1/ In conformity with annex 7 of the Consolidated Resolution on the Construction of Vehicles (R.E.3), (TRANS/WP.29/78/Rev.1/Amend.2)"

Paragraph 2., amend to read:

"2. DEFINITIONS AND ABBREVIATIONS

For the purposes of this Regulation:

- 2.1. "test cycle" means a sequence of test points each with a defined speed and torque to be followed by the engine under steady state (ESC test) or transient operating conditions (ETC, ELR test);
- 2.2. "approval of an engine (engine family)" means the approval of an engine type (engine family) with regard to the level of the emission of gaseous and particulate pollutants;
- 2.3. "diesel engine" means an engine which works on the compression-ignition principle;  
"gas engine" means an engine, which is fuelled with natural gas (NG) or liquid petroleum gas (LPG);
- 2.4. "engine type" means a category of engines which do not differ in such essential respects as engine characteristics as defined in annex 1 to this Regulation;
- 2.5. "engine family" means a manufacturers grouping of engines which, through their design as defined in annex 1, appendix 2 to this Regulation, have similar exhaust emission characteristics; all members of the family must comply with the applicable emission limit values;
- 2.6. "parent engine" means an engine selected from an engine family in such a way that its emissions characteristics will be representative for that engine family;
- 2.7. "gaseous pollutants" means carbon monoxide, hydrocarbons (assuming a ratio of  $CH_{1.85}$  for diesel,  $CH_{2.525}$  for LPG and  $CH_{2.93}$  for NG (NMHC)), methane (assuming a ratio of  $CH_4$  for NG) and oxides of nitrogen, the last-named being expressed in nitrogen dioxide ( $NO_2$ ) equivalent;  
"particulate pollutants" means any material collected on a specified filter medium after diluting the exhaust with clean filtered air so that the temperature does not exceed 325 K (52°C);
- 2.8. "smoke" means particles suspended in the exhaust stream of a diesel engine which absorb, reflect, or refract light;
- 2.9. "net power" means the power in ECE kW obtained on the test bench at the end of the crankshaft, or its equivalent, measured in accordance with the method of measuring power as set out in Regulation No. 24.
- 2.10. "declared maximum power ( $P_{max}$ )" means the maximum power in ECE kW (net power) as declared by the manufacturer in his application for approval;

- 2.11. "per cent load" means the fraction of the maximum available torque at an engine speed;
- 2.12. "ESC test" means a test cycle consisting of 13 steady state modes to be applied in accordance with paragraph 5.2. of this Regulation;
- 2.13. "ELR test" means a test cycle consisting of a sequence of load steps at constant engine speeds to be applied in accordance with paragraph 5.2. of this Regulation;
- 2.14. "ETC test" means a test cycle consisting of 1800 second-by-second transient modes to be applied in accordance with paragraph 5.2. of this Regulation;
- 2.15. "engine operating speed range" means the engine speed range, most frequently used during engine field operation, which lies between the low and high speeds, as set out in annex 4 to this Regulation;
- 2.16. "low speed ( $n_{100}$ )" means the lowest engine speed where 50 per cent of the declared maximum power occurs;
- 2.17. "high speed ( $n_{hi}$ )" means the highest engine speed where 70 per cent of the declared maximum power occurs;
- 2.18. "engine speeds A, B and C" means the test speeds within the engine operating speed range to be used for the ESC test and the ELR test, as set out in annex 4, appendix 1 to this Regulation;
- 2.19. "control area" means the area between the engine speeds A and C and between 25 to 100 per cent load;
- 2.20. "reference speed ( $n_{ref}$ )" means the 100 per cent speed value to be used for denormalizing the relative speed values of the ETC test, as set out in annex 4, appendix 2 to this Regulation;
- 2.21. "opacimeter" means an instrument designed to measure the opacity of smoke particles by means of the light extinction principle;
- 2.22. "NG gas range" means one of the H or L range as defined in European Standard EN 437, dated November 1993;
- 2.23. "self adaptability" means any engine device allowing the air/fuel ratio to be kept constant;
- 2.24. "recalibration" means a fine-tuning of a NG engine in order to provide the same performance (power, fuel consumption) in a different range of natural gas;
- 2.25. "Wobbe Index (lower  $W_l$ ; or upper  $W_u$ )" means the ratio of the corresponding calorific value of a gas per unit volume and the square root of its relative density under the same reference conditions:

$$W = H_{\text{gas}} \times \sqrt{\rho_{\text{air}} / \rho_{\text{gas}}}$$

- 2.26. "ë-shift factor ( $S_{\text{ë}}$ )" means an expression that describes the required flexibility of the engine management system regarding a change of the excess-air ratio  $\text{ë}$  if the engine is fuelled with a gas composition different from pure methane (see annex 8 for the calculation of  $S_{\text{ë}}$ ).
- 2.27. "EEV" means Enhanced Environmentally Friendly Vehicle which is a type of vehicle propelled by an engine complying with the permissive emission limit values given in row C of the Tables in paragraph 5.2.1. of this Regulation;
- 2.28. "Defeat Device" means any element of engine or vehicle design, which measures or senses vehicle speed, engine speed, gear used, temperature, intake pressure or any other parameter, with a view to activating, modulating delaying or deactivating the operation of any component of the emission control system, so that the effectiveness of the emission control system is reduced under conditions encountered in normal vehicle use.

Such a device will not be regarded as a defeat device if:

- 2.28.1. the need for the device is justified temporarily to protect the engine against intermittent operating conditions that could lead to damage or failure and no other measures are applicable for the same purpose which do not reduce the effectiveness of the emission control system;
- 2.28.2. the device operates only when needed during engine starting and/or warming-up and no other measures are applicable for the same purpose which do not reduce the effectiveness of the emission control system.

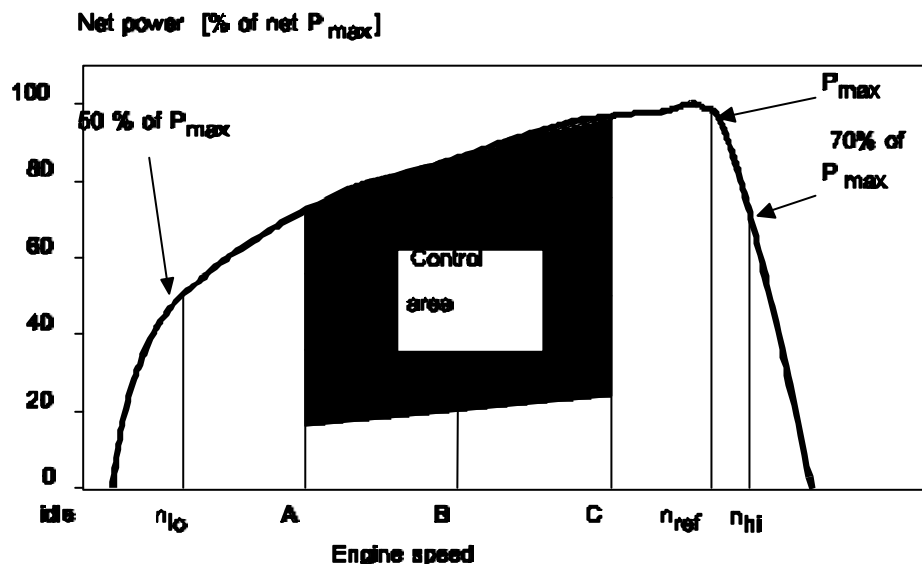

Figure 1: Specific definitions of the test cycles

## 2.29. Symbols and Abbreviations

## 2.29.1. Symbols for Test Parameters

<u>Symbol</u>	<u>Unit</u>	<u>Term</u>
$A_P$	$m^2$	Cross sectional area of the isokinetic sampling probe
$A_T$	$m^2$	Cross sectional area of the exhaust pipe
$CE_E$	-	Ethane efficiency
$CE_M$	-	Methane efficiency
$C_1$	-	Carbon 1 equivalent hydrocarbon
conc	ppm / vol%	Subscript denoting concentration
$D_0$	$m^3/s$	Intercept of PDP calibration function
$DF$	-	Dilution factor
$D$	-	Bessel function constant
$E$	-	Bessel function constant
$E_Z$	g/kWh	Interpolated $NO_x$ emission of the control point
$f_a$	-	Laboratory atmospheric factor
$f_c$	$s^{-1}$	Bessel filter cut-off frequency
$F_{FH}$	-	Fuel specific factor for the calculation of wet concentration for dry concentration
$F_S$	-	Stoichiometric factor
$G_{AIRW}$	kg/h	Intake air mass flow rate on wet basis
$G_{AIRD}$	kg/h	Intake air mass flow rate on dry basis
$G_{DILW}$	kg/h	Dilution air mass flow rate on wet basis
$G_{EDFW}$	kg/h	Equivalent diluted exhaust gas mass flow rate on wet basis
$G_{EXHW}$	kg/h	Exhaust gas mass flow rate on wet basis
$G_{FUEL}$	kg/h	Fuel mass flow rate
$G_{TOTW}$	kg/h	Diluted exhaust gas mass flow rate on wet basis
$H$	$MJ/m^3$	Calorific value
$H_{REF}$	g/kg	Reference value of absolute humidity (10.71g/kg)
$H_a$	g/kg	Absolute humidity of the intake air
$H_d$	g/kg	Absolute humidity of the dilution air
$HTCRAT$	mol/mol	Hydrogen-to-Carbon ratio
$i$	-	Subscript denoting an individual mode
$K$	-	Bessel constant
$k$	$m^{-1}$	Light absorption coefficient
$K_{H,D}$	-	Humidity correction factor for $NO_x$ for diesel engines
$K_{H,G}$	-	Humidity correction factor for $NO_x$ for gas engines
$K_V$	-	CFV calibration function
$K_{W,a}$	-	Dry to wet correction factor for the intake air
$K_{W,d}$	-	Dry to wet correction factor for the dilution air
$K_{W,e}$	-	Dry to wet correction factor for the diluted exhaust gas
$K_{W,r}$	-	Dry to wet correction factor for the raw exhaust gas
$L$	%	Percent torque related to the maximum

<u>Symbol</u>	<u>Unit</u>	<u>Term</u>
		torque for the test engine
$L_a$	m	Effective optical path length
m		Slope of PDP calibration function
mass	g/h or g	Subscript denoting emissions mass flow (rate)
$M_{DIL}$	kg	Mass of the dilution air sample passed through the particulate sampling filters
$M_d$	mg	Particulate sample mass of the dilution air collected
$M_f$	mg	Particulate sample mass collected
$M_{f,p}$	mg	Particulate sample mass collected on primary filter
$M_{f,b}$	mg	Particulate sample mass collected on back-up filter
$M_{SAM}$	kg	Mass of the diluted exhaust sample passed through the particulate sampling filters
$M_{SEC}$	kg	Mass of secondary dilution air
$M_{TOTW}$	kg	Total CVS mass over the cycle on wet basis
$M_{TOTW,i}$	kg	Instantaneous CVS mass on wet basis
N	%	Opacity
$N_p$	-	Total revolutions of PDP over the cycle
$N_{p,i}$	-	Revolutions of PDP during a time interval
n	$\text{min}^{-1}$	Engine speed
$n_p$	$\text{s}^{-1}$	PDP speed
$n_{hi}$	$\text{min}^{-1}$	High engine speed
$n_{lo}$	$\text{min}^{-1}$	Low engine speed
$n_{ref}$	$\text{min}^{-1}$	Reference engine speed for ETC test
$p_a$	kPa	Saturation vapour pressure of the engine intake air
$p_A$	kPa	Absolute pressure
$p_B$	kPa	Total atmospheric pressure
$p_d$	kPa	Saturation vapour pressure of the dilution air
$p_s$	kPa	Dry atmospheric pressure
$p_1$	kPa	Pressure depression at pump inlet
$P(a)$	kW	Power absorbed by auxiliaries to be fitted for test
$P(b)$	kW	Power absorbed by auxiliaries to be removed for test
$P(n)$	kW	Net power non-corrected
$P(m)$	kW	Power measured on test bed
$\tilde{U}$	-	Bessel constant
$Q_s$	$\text{m}^3/\text{s}$	CVS volume flow rate
q	-	Dilution ratio
r	-	Ratio of cross sectional areas of isokinetic probe and exhaust pipe
$R_a$	%	Relative humidity of the intake air
$R_d$	%	Relative humidity of the dilution air
$R_f$	-	FID response factor
$\tilde{n}$	$\text{kg}/\text{m}^3$	density
S	kW	Dynamometer setting
$S_i$	$\text{m}^{-1}$	Instantaneous smoke value
$S_{\check{e}}$	-	ë-shift factor
T	K	Absolute temperature
$T_a$	K	Absolute temperature of the intake air

<u>Symbol</u>	<u>Unit</u>	<u>Term</u>
t	s	Measuring time
t <sub>e</sub>	s	Electrical response time
t <sub>f</sub>	s	Filter response time for Bessel function
t <sub>p</sub>	s	Physical response time
Δt	s	Time interval between successive smoke data (= 1/sampling rate)
Δt <sub>i</sub>	s	Time interval for instantaneous CFV flow
ô	%	Smoke transmittance
V <sub>0</sub>	m <sup>3</sup> /rev	PDP volume flow rate at actual conditions
W	-	Wobbe index
W <sub>act</sub>	kWh	Actual cycle work of ETC
W <sub>ref</sub>	kWh	Reference cycle work of ETC
WF	-	Weighting factor
WF <sub>E</sub>	-	Effective weighting factor
X <sub>0</sub>	m <sup>3</sup> /rev	Calibration function of PDP volume flow rate
Y <sub>i</sub>	m <sup>-1</sup>	1 s Bessel averaged smoke value

### 2.29.2. Symbols for the Chemical Components

CH <sub>4</sub>	Methane
C <sub>2</sub> H <sub>6</sub>	Ethane
C <sub>3</sub> H <sub>8</sub>	Propane
CO	Carbon monoxide
DOP	Di-octylphtalate
CO <sub>2</sub>	Carbon dioxide
HC	Hydrocarbons
NMHC	Non-methane hydrocarbons
NO <sub>x</sub>	Oxides of nitrogen
NO	Nitric oxide
NO <sub>2</sub>	Nitrogen dioxide
PT	Particulates

### 2.29.3. Abbreviations

CFV	Critical flow venturi
CLD	Chemiluminescent detector
ELR	European Load Response Test
ESC	European Steady State Cycle
ETC	European Transient Cycle
FID	Flame Ionisation Detector
GC	Gas Chromatograph
HCLD	Heated Chemiluminescent Detector
HFID	Heated Flame Ionisation Detector
LPG	Liquefied Petroleum Gas
NDIR	Non-Dispersive Infrared Analyser
NG	Natural Gas
NMC	Non-Methane Cutter

Paragraph 3.2., amend to read:

"3.2. Application for approval of a vehicle type in respect of its engine"

Insert new paragraphs 3.3. to 3.2.1., to read:

"3.3. Application for approval for a vehicle type with an approved engine

3.3.1. The application for approval of a vehicle with regard to emission of gaseous and particulate pollutants by its approved diesel engine or engine family and with regard to the level of the emission of gaseous pollutants by its approved gas engine or engine family must be submitted by the vehicle manufacturer or a duly accredited representative.

3.3.2. It must be accompanied by the necessary documents in triplicate and the following particulars:

3.3.2.1. a description of the vehicle type and of engine-related vehicle parts comprising the particulars referred to in annex 1, as applicable, and a copy of the approval communication form (annex 2a) for the engine or engine family, if applicable, as a separate technical unit which is installed in the vehicle type."

Paragraph 3.3. (former), should be deleted.

Paragraph 4.1., amend to read:

"4.1. Universal fuel approval

A universal fuel approval is granted subject to the following requirements:

4.1.1. pursuant to paragraphs 3.1. or 3.2. of this Regulation meets the requirements of paragraphs 5 and 6 below, approval of that type of engine or the vehicle must be granted.

4.1.2. In the case of natural gas the parent engine should demonstrate its capability to adapt to any fuel composition that may occur across the market. In the case of natural gas there are generally two types of fuel, high calorific fuel (H-gas) and low calorific fuel (L-gas), but with a significant spread within both ranges; they differ significantly in their energy content expressed by the Wobbe Index and in their  $\bar{e}$ -shift factor ( $S_{\bar{e}}$ ). The formulae for the calculation of the Wobbe index and  $S_{\bar{e}}$  are given in paragraphs 2.25 and 2.26. The composition of the reference fuels reflects the variations of those parameters.

The parent engine must meet the requirements of this Regulation on the reference fuels G20 and G25, as specified in annex 6, without any readjustment to the fuelling between the two tests. However, one adaptation run over one ETC cycle without measurement is permitted, after the change of the fuel. Before testing, the parent engine must be run-in using the procedure given in paragraph 3 of appendix 2 to annex 4.



4.1.3. In the case of an engine fuelled with natural gas which is self-adaptive for the range of H-gases on the one hand and the range of L-gases on the other hand, and which switches between the H-range and the L-range by means of a switch, the parent engine must be tested on the two relevant reference fuels as specified in annex 6 for each range, at each position of the switch. The fuels are G20 (fuel 1) and G23 (fuel 2) for the H-range of gases, G23 (fuel 1) and G25 (fuel 2) for the L-range of gases. The parent engine must meet the requirements of this Regulation at both positions of the switch without any readjustment to the fuelling between the two tests at each position of the switch. However, one adaptation run over one ETC cycle without measurement is permitted, after the change of the fuel. Before testing the parent engine must be run-in using the procedure given in paragraph 3 of appendix 2 to annex 4.

4.1.3.1. On the manufacturer's request the engine may be tested on a third fuel (fuel 3) if the  $\ddot{e}$ -shift factor ( $S_{\ddot{e}}$ ) lies between those of the fuels G20 and G25, e.g. when fuel 3 is a market fuel. The results of this test may be used as a basis for the evaluation of the conformity of the production.

4.1.3.2. The ratio of emission results "r" must be determined for each pollutant as follows:

$$r = \frac{\text{emission result on reference fuel 2}}{\text{emission result on reference fuel 1}}$$

or,

$$r_a = \frac{\text{emission result on reference fuel 2}}{\text{emission result on reference fuel 3}}$$

and,

$$r_b = \frac{\text{emission result on reference fuel 1}}{\text{emission result on reference fuel 3}}$$

4.1.4. In the case of LPG the parent engine should demonstrate its capability to adapt to any fuel composition that may occur across the market. In the case of LPG there are variations in C<sub>3</sub>/C<sub>4</sub> composition. These variations are reflected in the reference fuels. The parent engine should meet the emission requirements on the reference fuels A and B as specified in annex 7 without any readjustment to the fuelling between the two tests. However, one adaptation run over one ETC cycle without measurement is permitted, after the change of the fuel. Before testing the parent engine must be run-in using the procedure defined in paragraph 3 of appendix 2 to annex 4.

4.1.4.1. The ratio of emission results "r" must be determined for each pollutant as follows:

$$r = \frac{\text{emission result on reference fuel 2}}{\text{emission result on reference fuel 1}}$$

Insert new paragraphs 4.2. to 4.3.2., to read:

"4.2. Granting of a fuel range restricted approval

At the present state of technology it is not yet possible to make lean-burn natural gas engines self-adaptive. Yet these engines offer an advantage in efficiency and CO<sub>2</sub> emission. If a user has the guarantee of a supply of fuel of uniform composition, he may opt for a lean-burn engine. Such an engine could be given a fuel-restricted approval. In the interest of international harmonisation it is regarded desirable that a specimen of such an engine is granted international approval. Fuel restricted variants would then need to be identical except for the contents of the database of the ECU of the fuelling system, and such parts of the fuelling system (such as injector nozzles) that need to be adapted to the different fuel flow.

Fuel range restricted approval is granted subject to the following requirements:

- 4.2.1. Exhaust emissions approval of an engine running on natural gas and laid out for operation on either the range of H-gases or on the range of L-gases

The parent engine must be tested on the two relevant reference fuels as specified in annex 6 for the relevant range. The fuels are G20 (fuel 1) and G23 (fuel 2) for the H-range of gases, G23 (fuel 1) and G25 (fuel 2) for the L-range of gases. The parent engine must meet the emission requirements without any readjustment to the fuelling between the two tests. However, one adaptation run over one ETC cycle without measurement is permitted, after the change of the fuel. Before testing the parent engine must be run-in using the procedure defined in paragraph 3 of appendix 2 to annex 4.

- 4.2.1.1. On the manufacturer's request it may be tested on a third fuel (fuel 3) if the  $\bar{e}$ -shift factor ( $S_{\bar{e}}$ ) lies between those of the fuels G20 and G23, or G23 and G25 respectively, e.g. when fuel 3 is a market fuel. The results of this test may be used as a basis for the evaluation of the conformity of the production.
- 4.2.1.2. The ratio of emission results "r" must be determined for each pollutant as follows:

$$r = \frac{\text{emission result on reference fuel 2}}{\text{emission result on reference fuel 1}}$$

or,

$$r_a = \frac{\text{emission result on reference fuel 2}}{\text{emission result on reference fuel 3}}$$

and,

$$r_b = \frac{\text{emission result on reference fuel 1}}{\text{emission result on reference fuel 3}}$$

- 4.2.1.3. Upon delivery to the customer the engine must bear a label (see paragraph 4.11.) stating for which range of gases the engine is approved.
- 4.2.2. Exhaust emissions approval of an engine running on natural gas or LPG and laid out for operation on one specific fuel composition
  - 4.2.2.1. The parent engine must meet the emission requirements on the reference fuels G20 and G25 in the case of natural gas, or the reference fuels A and B in the case of LPG, as specified in annex 7. Between the tests fine-tuning of the fuelling system is allowed. This fine-tuning will consist of a recalibration of the fuelling database, without any alteration to either the basic control strategy or the basic structure of the database. If necessary the exchange of parts that are directly related to the amount of fuel flow (such as injector nozzles) is allowed.
  - 4.2.2.2. If the manufacturer so desires the engine may be tested on the reference fuels G20 and G23, or G23 and G25, in which case the approval is only valid for the H-range or the L-range of gases respectively.
  - 4.2.2.3. Upon delivery to the customer the engine must bear a label (see paragraph 5.1.5.) stating for which fuel composition the engine has been calibrated.

4.3. Exhaust emissions approval of a member of a family

- 4.3.1. With the exception of the case mentioned in paragraph 4.3.2., the approval of a parent engine must be extended to all family members without further testing, for any fuel composition within the range for which the parent engine has been approved (in the case of engines described in paragraph 4.2.2) or the same range of fuels (in the case of engines described in either paragraphs 4.1. or 4.2) for which the parent engine has been approved.

4.3.2. Secondary test engine

In case of an application for approval of an engine, or a vehicle in respect of its engine, that engine belonging to an engine family, if the approval authority determines that, with regard to the selected parent engine the submitted application does not fully represent the engine family defined in the Regulation, appendix 1, an alternative and, if necessary, an additional reference test engine may be selected by the approval authority and tested."

Paragraph 4.2. (former), renumber as paragraph 4.4., and amend to read:

- "4.4. An approval number shall be assigned to each type approved. Its first two digits (at present 03, corresponding to 03 series of amendments which entered into force on [.....]) shall indicate the series ...."

Paragraphs 4.3. and 4.4. (former), renumber as paragraphs 4.5. and 4.6.

Paragraph 4.4.1. (former), renumber as 4.6.1., and footnote 4/, amend to read:

"4/ 1 for Germany, ... 24 for Ireland, 25 for Croatia, 26 for Slovenia, 27 for Slovakia, 28 for Belarus, 29 for Estonia, 30 (vacant), 31 for Bosnia and Herzegovina, 32 for Latvia, 33 (vacant), 34 for Bulgaria, 35-36 (vacant), 37 for Turkey, 38-39 (vacant), 40 for the former Yugoslav Republic of Macedonia, 41 (vacant), 42 for the European Community (Approvals are granted by its Member States using their respective ECE symbol), 43 for Japan, 44 (vacant), 45 for Australia and 46 for Ukraine. Subsequent numbers shall be assigned to other countries in the chronological order in which they ratify or accede to the Agreement Concerning the Adoption of Uniform Technical Prescriptions for Wheeled Vehicles, Equipment and Parts which can be Fitted and/or be Used on Wheeled Vehicles and the Conditions for Reciprocal Recognition of Approvals Granted on the Basis of these Prescriptions, and the numbers thus assigned ....."

Paragraph 4.4.2., renumber as paragraph 4.6.2.

Paragraph 4.4.3., renumber as paragraph 4.6.3., and amend to read:

- "4.6.3. However, the approval mark must contain an additional character after the letter "R", the purpose of which is to distinguish the emission limit values for which the approval has been granted. For those approvals issued to indicate compliance with the limits contained in Row A of the relevant table(s) in paragraph 5.2.1., the letter "R" will be followed by the Roman number "I". For those approvals issued to indicate compliance with the limits contained in Row B1 of the relevant table(s) in paragraph 5.2.1., the letter "R" will be followed by the Roman number "II". For those approvals issued to indicate compliance with the limits contained in Row B2 of the relevant table(s) in paragraph 5.2.1., the letter "R" will be followed by the Roman number "III". For those approvals issued to indicate compliance with the limits contained in Row C of the relevant table(s) in paragraph 5.2.1., the letter "R" will be followed by the Roman number "IV".
- 4.6.3.1. For NG fuelled engines the approval mark must contain a suffix after the national symbol, the purpose of which is to distinguish which range of gases the approval has been granted. This mark will be as follows;
- 4.6.3.1.1. H in case of the engine being approved and calibrated for the H-range of gases;
- 4.6.3.1.2. L in case of the engine being approved and calibrated for the L-range of gases;
- 4.6.3.1.3. HL in case of the engine being approved and calibrated for both the H-range and L-range of gases;
- 4.6.3.1.4. Ht in case of the engine being approved and calibrated for a specific gas composition in the H-range of gases and transformable to another specific gas in the H-range of gases by fine tuning of the engine fuelling;

- 4.6.3.1.5. It in case of the engine being approved and calibrated for a specific gas composition in the L-range of gases and transformable to another specific gas in the L-range of gases after fine tuning of the engine fuelling;
- 4.6.3.1.6. HIt in the case of the engine being approved and calibrated for a specific gas composition in either the H-range or the L-range of gases and transformable to another specific gas in either the H-range or the L-range of gases by fine tuning of the engine fuelling."

Paragraph 4.5. (former), renumber as paragraph 4.7., and amend to read:

- "4.7. If the vehicle or engine conforms to an approved type under one or more other Regulations annexed to the Agreement, in the country which has granted approval under this Regulation, the symbol prescribed in paragraph 4.6.1. need not be repeated. In such a case, the Regulation and approval numbers and the additional symbols of all the Regulations under which approval has been granted under this Regulation shall be placed in vertical columns to the right of the symbol prescribed in paragraph 4.6.1."

Paragraphs 4.6. to 4.8.2., renumber as paragraphs 4.9. to 4.10.2.

Paragraph 4.9., renumber as paragraph 4.11., and amend to read:

"4.11. Labels

In the case of NG and LPG fuelled engines with a fuel range restricted type approval, the following labels are applicable:

4.11.1. Content

The following information must be given:

In the case of paragraph 4.2.1.3, the label shall state "ONLY FOR USE WITH NATURAL GAS RANGE H". If applicable, "H" is replaced by "L".

In the case of paragraph 4.2.2.3, the label shall state "ONLY FOR USE WITH NATURAL GAS SPECIFICATION ....." or "ONLY FOR USE WITH LIQUEFIED PETROLEUM GAS SPECIFICATION .....", as applicable. All the information in the relevant table(s) in Annex 6 or 7 shall be given with the individual constituents and limits specified by the engine manufacturer.

The letters and figures must be at least 4 mm in height.

Note:

If lack of space prevents such labelling, a simplified code may be used. In this event, explanatory notes containing all the above information must be easily accessible to any person filling the fuel tank or performing maintenance or repair on the engine and its accessories, as well as to the authorities concerned. The site and

content of these explanatory notes will be determined by agreement between the manufacturer and the approval authority.

4.11.2. Properties

Labels must be durable for the useful life of the engine. Labels must be clearly legible and their letters and figures must be indelible. Additionally, labels must be attached in such a manner that their fixing is durable for the useful life of the engine, and the labels cannot be removed without destroying or defacing them.

4.11.3. Placing

Labels must be secured to an engine part necessary for normal engine operation and not normally requiring replacement during engine life. Additionally, these labels must be located so as to be readily visible to the average person after the engine has been completed with all the auxiliaries necessary for engine operation."

Insert new paragraphs 4.12. and 4.13., to read:

"4.12. In case of an application for type-approval for a vehicle type in respect of its engine, the marking specified in paragraph 4.11. must also be placed close to fuel filling aperture.

4.13. In case of an application for type-approval for a vehicle type with an approved engine, the marking specified in paragraph 4.11. must also be placed close to the fuel filling aperture."

Insert new paragraph 5.1.1., to read:

"5.1.1. The use of a defeat device and/or irrational emissions control strategy is forbidden. If the approval authority suspects that a vehicle type utilises defeat device(s) and/or any irrational emission control strategy under certain operating conditions, upon request the manufacturer has to provide information on the operation and effect on emissions of the use of such devices and/or control strategy. Such information must include a description of all emission control components, fuel control system logic including timing strategies and switch points during all modes of operation. This information should remain strictly confidential and not be attached to the documentation required in paragraph 3."

Paragraph 5.2., amend to read:

"5.2. For approval to row A of the tables in paragraph 5.2.1., the emissions must be determined on the ESC and ELR tests with conventional diesel engines including those fitted with electronic fuel injection equipment, exhaust gas recirculation (EGR), and/or oxidation catalysts. Diesel engines fitted with advanced exhaust after-treatment systems including deNOx catalysts and/or particulate traps, must additionally be tested on the ETC test.

For approval testing to either row B1 or B2 or row C of the tables in paragraph 5.2.1. the emissions must be determined on the ESC, ELR and ETC tests.

For gas engines, the gaseous emissions must be determined on the ETC test.

The ESC and ELR test procedures are described in annex 4, appendix 1, the ETC test procedure in annex 4, Appendices 2 and 3.

The emissions of gaseous pollutants and particulate pollutants, by the engine submitted for testing, if applicable, must be measured by the method described in annex 4 annex 4, appendix 4 describes .....

Paragraph 5.2.1., amend to read:

"5.2.1. Limit Values

The specific mass of the carbon monoxide, of the total hydrocarbons, of the oxides of nitrogen and of the particulates, as determined on the ESC test, and of the smoke opacity, as determined on the ELR test, must not exceed the amounts shown in Table 1. For diesel engines that are additionally tested on the ETC test, and specifically for gas engines, the specific masses of the carbon monoxide, of the non-methane hydrocarbons, of the methane (where applicable), of the oxides of nitrogen and of the particulates (where applicable) must not exceed the amounts shown in Table 2.

Table 1 Limit values - ESC and ELR tests

Row	Mass of Carbon Monoxide (CO) g/kWh	Mass of Hydrocarbons (HC) g/kWh	Mass of Nitrogen oxides (NOx) g/kWh	Mass of particulates (PT) g/kWh	Smoke m <sup>-1</sup>
A (2000)	2.1	0.66	5.0	0.10 0.13 <sup>(a)</sup>	0.8
B 1 (2005)	1.5	0.46	3.5	0.02	0.5
B 2 (2008)	1.5	0.46	2.0	0.02	0.5
C (EEV)	1.5	0.25	2.0	0.02	0.15

<sup>(a)</sup> For engines having a swept volume of less than 0.75 dm<sup>3</sup> per cylinder and a rated power speed of more than 3000 min<sup>-1</sup>.

Table 2 Limit values - ETC tests <sup>(b)</sup>

Row	Mass of Carbon monoxide (CO) g/kWh	Mass of Non-methane hydrocarbons (NMHC) g/kWh	Mass of methane (CH <sub>4</sub> ) <sup>(c)</sup> g/kWh	Mass of Nitrogen oxides (NOx) g/kWh	Mass of particulates (PT) <sup>(d)</sup> g/kWh
A (2000)	5.45	0.78	1.6	5.0	0.16 0.21 <sup>(a)</sup>
B1 (2005)	4.0	0.55	1.1	3.5	0.03
B2 (2008)	4.0	0.55	1.1	2.0	0.03
C (EEV)	3.0	0.40	0.65	2.0	0.02

- (a) For engines having a swept volume of less than  $0.75 \text{ dm}^3$  per cylinder and a rated power speed of more than  $3000 \text{ min}^{-1}$ .
- (b) The conditions for verifying the acceptability of the ETC tests (see annex 4, appendix 2, paragraph 3.9.) when measuring the emissions of gas fuelled engines against the limit values applicable in row A must be re-examined and, where necessary, modified in accordance with the procedure laid down in Consolidated Resolution R.E.3.
- (c) For NG engines only.
- (d) Not applicable for gas fuelled engines at stage A and stages B1 and B2 ."

Insert new paragraphs 5.2.2. to 5.2.3.2., to read:

"5.2.2. Hydrocarbon measurement for diesel and gas fuelled engines

5.2.2.1. A manufacturer may choose to measure the mass of total hydrocarbons (THC) on the ETC test instead of measuring the mass of non-methane hydrocarbons. In this case, the limit for the mass of total hydrocarbons is the same as shown in table 2 for the mass of non-methane hydrocarbons.

5.2.3. Specific requirements for diesel engines

5.2.3.1. The specific mass of the oxides of nitrogen measured at the random check points within the control area of the ESC test must not exceed by more than 10 per cent the values interpolated from the adjacent test modes (reference annex 4, appendix 1 paragraphs 4.6.2. and 4.6.3.).

5.2.3.2. The smoke value on the random test speed of the ELR must not exceed the highest smoke value of the two adjacent test speeds by more than 20 per cent, or by more than 5 per cent of the limit value, whichever is greater."

Paragraph 6.1.3., amend to read:

"6.1.3. power absorbed by the auxiliaries needed for operating the engine must not exceed that specified for the type-approved engine in annex 2A."

Insert new paragraphs 7. to 7.2.2., to read:

"7. ENGINE FAMILY

7.1. Parameters defining the engine family

The engine family, as determined by the engine manufacturer, may be defined by basic characteristics, which must be common to engines within the family. In some cases there may be interaction of parameters. These effects must also be taken into consideration to ensure that only engines with similar exhaust emission characteristics are included within an engine family.



In order that engines may be considered to belong to the same engine family, the following list of basic parameters must be common:

7.1.1. Combustion cycle:

- 2 cycle
- 4 cycle

7.1.2. Cooling medium:

- air
- water
- oil

7.1.3. For gas engines and engines with after-treatment

- Number of cylinders

(other diesel engines with fewer cylinders than the parent engine may be considered to belong to the same engine family provided the fuelling system meters fuel for each individual cylinder).

7.1.4. Individual cylinder displacement:

- engines to be within a total spread of 15 per cent

7.1.5. Method of air aspiration:

- naturally aspirated
- pressure charged
- pressure charged with charge air cooler

7.1.6. Combustion chamber type/design:

- pre-chamber
- swirl chamber
- open chamber

7.1.7. Valve and porting - configuration, size and number:

- cylinder head
- cylinder wall
- crankcase

7.1.8. Fuel injection system (diesel engines):

- pump-line-injector
- in-line pump
- distributor pump
- single element
- unit injector

7.1.9. Fuelling system (gas engines):

- mixing unit
- gas induction/injection (single point, multi-point)
- liquid injection (single point, multi-point)

7.1.10. Ignition system (gas engines)

7.1.11. Miscellaneous features:

- exhaust gas recirculation
- water injection/emulsion
- secondary air injection
- charge cooling system

7.1.12. Exhaust after treatment:

- 3-way-catalyst
- oxidation catalyst
- reduction catalyst
- thermal reactor
- particulate trap

7.2. Choice of the parent engine

7.2.1. Diesel engines

The parent engine of the family must be selected using the primary criteria of the highest fuel delivery per stroke at the declared maximum torque speed. In the event that two or more engines share this primary criteria, the parent engine must be selected using the secondary criteria of highest fuel delivery per stroke at rated speed. Under certain circumstances, the approval authority may conclude that the worst case emission rate of the family can best be characterised by testing a second engine. Thus, the approval authority may select an additional engine for test based upon features, which indicate that it may have the highest emission level of the engines within that family.

If engines within the family incorporate other variable features, which could be considered to affect exhaust emissions, these features must also be identified and taken into account in the selection of the parent engine.

7.2.2. Gas engines

The parent engine of the family must be selected using the primary criteria of the largest displacement. In the event that two or more engines share this primary criteria, the parent engine must be selected using the secondary criteria in the following order:

- the highest fuel delivery per stroke at the speed of declared rated power;
- the most advanced spark timing;
- the lowest EGR rate;
- no air pump or lowest actual air flow pump.

Under certain circumstances, the approval authority may conclude that the worst case emission rate of the family can best be characterised by testing a second engine. Thus, the approval authority may select an additional engine for test based upon features, which indicate that it may have the highest emission level of the engines within that family."

Paragraphs 7. to 7.4.4., replace by the following text (paragraphs 8. to 8.3.2.6., including also new Figure 2):

"8. CONFORMITY OF PRODUCTION

The conformity of production procedures shall comply with those set out in the Agreement, appendix 2 (E/ECE/324-E/ECE/TRANS/505/Rev.2), with the following requirements:

- 8.1. Every engine or vehicle bearing an approval mark as prescribed under this Regulation shall be so manufactured as to conform, with regard to the description as given in the approval form and its annexes, to the approved type.
- 8.2. As a general rule, conformity of production with regard to limitation of emissions is checked based on the description given in the communication form and its annexes.

8.3. If emissions of pollutants are to be measured and an engine approval has had one or several extensions, the tests will be carried out on the engine(s) described in the information package relating to the relevant extension.

8.3.1. Conformity of the engine subjected to a pollutant test:

After submission of the engine to the authorities, the manufacturer must not carry out any adjustment to the engines selected.

8.3.1.1. Three engines are randomly taken in the series. Engines that are subject to testing only on the ESC and ELR tests or only on the ETC test for approval to row A of the tables in paragraph 5.2.1. are subject to those applicable tests for the checking of production conformity. With the agreement of the authority, all other engines approved to row A, B1 or B2, or C of the tables in paragraph 5.2.1. are subjected to testing either on the ESC and ELR cycles or on the ETC cycle for the checking of the production conformity. The limit values are given in paragraph 5.2.1. of the Regulation.

8.3.1.2. The tests are carried out according to appendix 1 to this Regulation, where the competent authority is satisfied with the production standard deviation given by the manufacturer.

The tests are carried out according to appendix 2 to this Regulation, where the competent authority is not satisfied with the production standard deviation given by the manufacturer.

At the manufacturer's request, the tests may be carried out in accordance with appendix 3 to this Regulation.

- 8.3.1.3. On the basis of a test of the engine by sampling, the production of a series is regarded as conforming where a pass decision is reached for all the pollutants and non conforming where a fail decision is reached for one pollutant, in accordance with the test criteria applied in the appropriate appendix.

When a pass decision has been reached for one pollutant, this decision may not be changed by any additional tests made in order to reach a decision for the other pollutants.

If no pass decision is reached for all the pollutants and if no fail decision is reached for one pollutant, a test is carried out on another engine (see figure 2).

If no decision is reached, the manufacturer may at any time decide to stop testing. In that case a fail decision is recorded.

- 8.3.2. The tests will be carried out on newly manufactured engines. Gas fuelled engines must be run-in using the procedure defined in paragraph 3 of appendix 2 to annex 4.
- 8.3.2.1. However, at the request of the manufacturer, the tests may be carried out on diesel or gas engines which have been run-in more than the period referred to in paragraph 8.4.2.2., up to a maximum of 100 hours. In this case, the running-in procedure will be conducted by the manufacturer who must undertake not to make any adjustments to those engines.
- 8.3.2.2. When the manufacturer asks to conduct a running-in procedure in accordance with paragraph 8.4.2.2.1., it may be carried out on:

- all the engines that are tested,

or,

- the first engine tested, with the determination of an evolution coefficient as follows:

- the pollutant emissions will be measured at zero and at "x" hours on the first engine tested,

- the evolution coefficient of the emissions between zero and "x" hours will be calculated for each pollutant:

$$\frac{\text{Emissions " x" hours}}{\text{Emissions zero hours}}$$

It may be less than one.

The subsequent test engines will not be subjected to the running-in procedure, but their zero hour emissions will be modified by the evolution coefficient.

In this case, the values to be taken will be:

- the values at "x" hours for the first engine,
- the values at zero hour multiplied by the evolution coefficient for the other engines.

8.3.2.3 For diesel and LPG fuelled engines, all these tests may be conducted with commercial fuel. However, at the manufacturer's request, the reference fuels described in annexes 5 or 7 may be used. This implies tests, as described in paragraph 4. of this Regulation, with at least two of the reference fuels for each gas engine.

8.3.2.4. For NG fuelled engines, all these tests may be conducted with commercial fuel in the following way:

for H marked engines with a commercial fuel within the H range;

for L marked engines with a commercial fuel within the L range;

for HL marked engines with a commercial fuel within the H or the L range.

However, at the manufacturer's request, the reference fuels described in annex 6 may be used. This implies tests, as described in paragraph 4. of this Regulation, with at least two of the reference fuels for each gas engine.

8.3.2.5. In the case of dispute caused by the non-compliance of gas fuelled engines, when using a commercial fuel, the tests must be performed with a reference fuel on which the parent engine has been tested, or with the possible additional fuel 3 as referred to in paragraphs 4.1.3.1. and 4.2.1.1., on which the parent engine may have been tested. Then, the result has to be converted by a calculation applying the relevant factor(s) "r", "r<sub>a</sub>" or "r<sub>b</sub>" as described in paragraphs 4.1.3.2., 4.1.4.1. and 4.2.1.2. If r, r<sub>a</sub> or r<sub>b</sub> are less than one no correction must take place. The measured results and the calculated results must demonstrate that the engine meets the limit values with all relevant fuels (fuels 1, 2 and, if applicable, fuel 3).

8.3.2.6. Tests for conformity of production of a gas fuelled engine laid out for operation on one specific fuel composition must be performed on the fuel for which the engine has been calibrated.

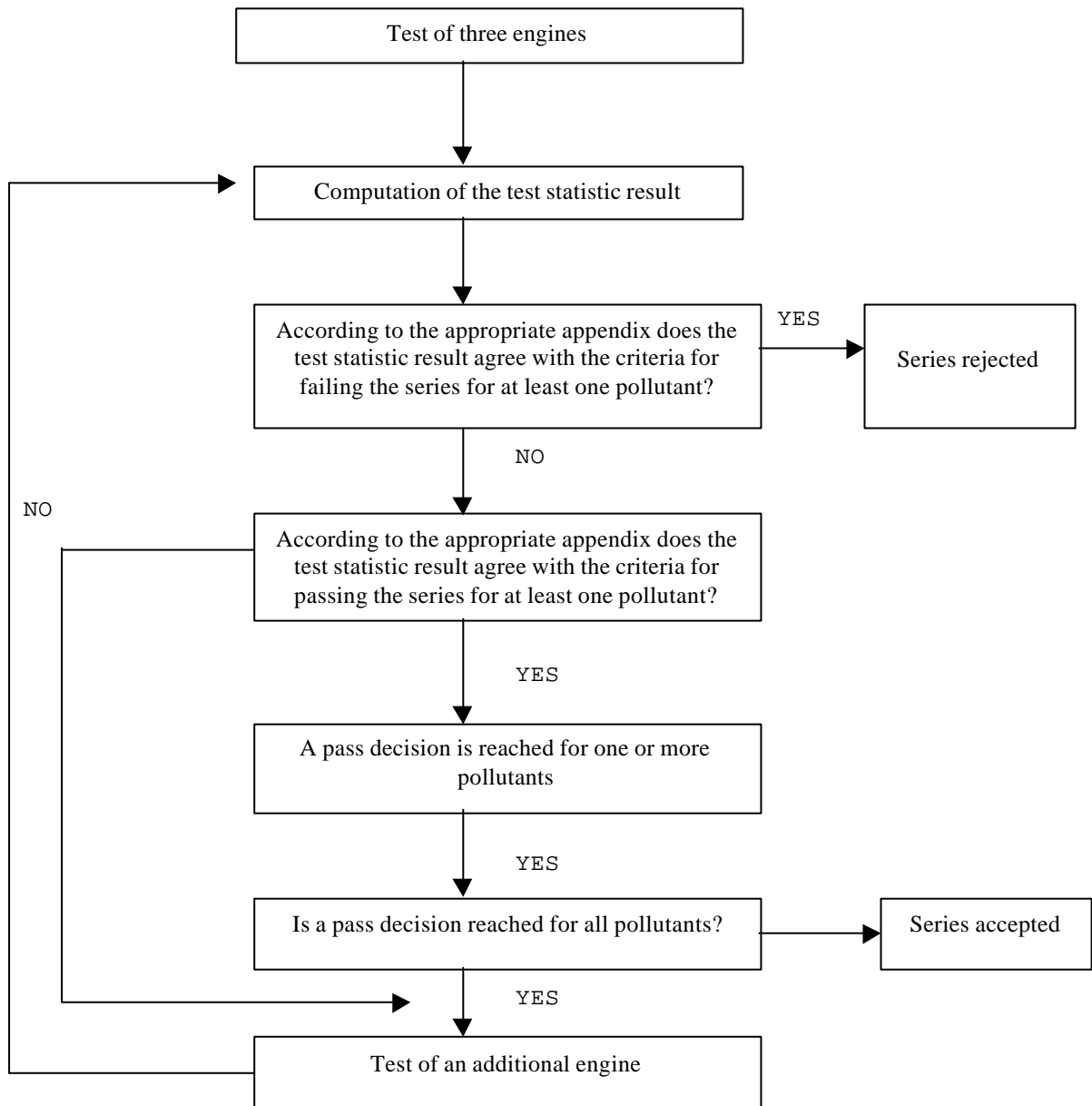

Figure 2: Conformity of production testing scheme"

Paragraphs 8. (former) to 10, renumber as paragraphs 9. to 11.

Paragraph 11. (former), renumber as paragraph 12. and amend to read:

"12. TRANSITIONAL PROVISIONS

12.1. General

12.1.1. As from the official date of entry into force of the 03 series of amendments, no Contracting Party applying this Regulation must refuse to grant ECE approval under this Regulation as amended by the 03 series of amendments.

12.1.2. As from the date of entry into force of the 03 series of amendments, Contracting Parties applying this Regulation must grant ECE approvals only if the engine meets the requirements of this Regulation as amended by the 03 series of amendments.

The engine must be subject to the relevant tests set out in paragraph 5.2. to this Regulation and must, in accordance with paragraphs 12.2.1., 12.2.2. and 12.2.3. below, satisfy the relevant emission limits detailed in paragraph 5.2.1. of this Regulation.

12.2. New type approvals

12.2.1. Subject to the provisions of paragraph 12.4.1., Contracting Parties applying this Regulation must, from the date of entry into force of the 03 series of amendments to this Regulation, grant an ECE approval to an engine only if that engine satisfies the relevant emission limits of Rows A, B1, B2 or C in the tables to paragraph 5.2.1. of this Regulation.

12.2.2. Subject to the provisions of paragraph 12.4.1., Contracting Parties applying this Regulation must, from 1 October 2005, grant an ECE approval to an engine only if that engine satisfies the relevant emission limits of Rows B1, B2 or C in the tables to paragraph 5.2.1. of this Regulation.

12.2.3. Subject to the provisions of paragraph 12.4.1., Contracting Parties applying this Regulation must, from 1 October 2008, grant an ECE approval to an engine only if that engine satisfies the relevant emission limits of Rows B2 or C in the tables to paragraph 5.2.1. of this Regulation.

12.3. Limit of validity of old type approvals

12.3.1. As from 1 October 2001, type approvals granted to this Regulation as amended by the 02 series of amendments must cease to be valid, unless the Contracting Party which granted the approval notifies the other Contracting Parties applying this Regulation that the engine type approved meets the requirements of this Regulation as amended by the 03 series of amendments, in accordance with paragraph 12.2.1. above.

12.3.2. As from 1 October 2006, type approvals granted to this Regulation as amended by the 03 series of amendments must cease to be valid, unless the Contracting Party which granted the approval notifies the other Contracting Parties applying this Regulation that the engine type

approved meets the requirements of this Regulation as amended by the 03 series of amendments, in accordance with paragraph 12.2.2. above.

- 12.3.3. As from 1 October 2009, type approvals granted to this Regulation as amended by the 03 series of amendments must cease to be valid, unless the Contracting Party which granted the approval notifies the other Contracting Parties applying this Regulation that the engine type approved meets the requirements of this Regulation as amended by the 03 series of amendments, in accordance with paragraph 12.2.3. above.

12.4. Replacement parts for vehicles in use

- 12.4.1. Contracting Parties applying this Regulation may continue to grant approvals to those engines which comply with the requirements of this Regulation as amended by any previous series of amendments, or to any level of the Regulation as amended by the 03 series of amendments, provided that the engine is intended as a replacement for a vehicle in-use and for which that earlier standard was applicable at the date of that vehicle's entry into service."

Paragraph 12.(former), renumber as paragraph 13.

Add to the Regulation new Appendices 1 to 3, to read:

"Appendix 1

PROCEDURE FOR PRODUCTION CONFORMITY TESTING  
WHEN STANDARD DEVIATION IS SATISFACTORY

1. This appendix describes the procedure to be used to verify production conformity for the emissions of pollutants when the manufacturer's production standard deviation is satisfactory.
2. With a minimum sample size of three engines, the sampling procedure is set so that the probability of a lot passing a test with 40 per cent of the engines defective is 0.95 (producer's risk = 5 per cent), while the probability of a lot being accepted with 65 per cent of the engines defective is 0.10 (consumer's risk = 10 per cent).
3. The following procedure is used for each of the pollutants given in paragraph 5.2.1. of the Regulation (see Figure 2):

Let:

L = the natural logarithm of the limit value for the pollutant;

$x_i$  = the natural logarithm of the measurement for the i-th engine of the sample;

s = an estimate of the production standard deviation (after taking the natural logarithm of the measurements);

n = the current sample number.



4. For each sample the sum of the standardised deviations to the limit is calculated using the following formula:

$$\frac{1}{s} \sum_{i=1}^n (L - x_i)$$

5. Then:

- if the test statistic result is greater than the pass decision number for the sample size given in table 3, a pass decision is reached for the pollutant;
- if the test statistic result is less than the fail decision number for the sample size given in table 3, a fail decision is reached for the pollutant;
- otherwise, an additional engine is tested according to paragraph 8.4.2.1. of the Regulation and the calculation procedure is applied to the sample increased by one more unit.

Table 3: Pass and Fail decision numbers of appendix 1 Sampling Plan

Minimum sample size: 3

Cumulative number of engines tested (sample size)	Pass decision number $A_n$	Fail decision number $B_n$
3	3.327	-4.724
4	3.261	-4.790
5	3.195	-4.856
6	3.129	-4.922
7	3.063	-4.988
8	2.997	-5.054
9	2.931	-5.120
10	2.865	-5.185
11	2.799	-5.251
12	2.733	-5.317
13	2.667	-5.383
14	2.601	-5.449
15	2.535	-5.515
16	2.469	-5.581
17	2.403	-5.647
18	2.337	-5.713
19	2.271	-5.779
20	2.205	-5.845
21	2.139	-5.911
22	2.073	-5.977
23	2.007	-6.043
24	1.941	-6.109
25	1.875	-6.175
26	1.809	-6.241
27	1.743	-6.307
28	1.677	-6.373
29	1.611	-6.439
30	1.545	-6.505
31	1.479	-6.571
32	-2.112	-2.112

-----

Appendix 2PROCEDURE FOR PRODUCTION CONFORMITY TESTING  
WHEN STANDARD DEVIATION IS UNSATISFACTORY OR UNAVAILABLE

1. This appendix describes the procedure to be used to verify production conformity for the emissions of pollutants when the manufacturer's production standard deviation is either unsatisfactory or unavailable.
2. With a minimum sample size of three engines, the sampling procedure is set so that the probability of a lot passing a test with 40 per cent of the engines defective is 0.95 (producer's risk = 5 per cent), while the probability of a lot being accepted with 65 per cent of the engines defective is 0.10 (consumer's risk = 10 per cent).
3. The values of the pollutants given in paragraph 5.2.1. of the Regulation are considered to be log normally distributed and should be transformed by taking their natural logarithms. Let  $m_0$  and  $m$  denote the minimum and maximum sample size respectively ( $m_0 = 3$  and  $m = 32$ ) and let  $n$  denote the current sample number.
4. If the natural logarithms of the values measured in the series are  $x_1, x_2, \dots, x_i$  and  $L$  is the natural logarithm of the limit value for the pollutant, then, define

$$d_i = x_i - L$$

and,

$$\bar{d}_n = \frac{1}{n} \sum_{i=1}^n d_i$$

$$V_n^2 = \frac{1}{n} \sum_{i=1}^n (d_i - \bar{d}_n)^2$$

5. Table 4 shows values of the pass ( $A_n$ ) and fail ( $B_n$ ) decision numbers against current sample number. The test statistic result is the ratio  $\bar{d}_n/V_n$  and must be used to determine whether the series has passed or failed as follows:

For  $m_0 \leq n \leq m$  :

- pass the series if  $\bar{d}_n/V_n \leq A_n$
- fail the series if  $\bar{d}_n/V_n \geq B_n$
- take another measurement if  $A_n < \bar{d}_n/V_n < B_n$

6. Remarks:

The following recursive formulae are useful for calculating successive values of the test statistic:

$$\bar{d}_n = \left(1 - \frac{1}{n}\right)\bar{d}_{n-1} + \frac{1}{n}d_n$$

$$V_n^2 = \left(1 - \frac{1}{n}\right)V_{n-1}^2 + \frac{(\bar{d}_n - d_n)^2}{n-1}$$

$$(n=2, 3, \dots; \bar{d}_1 = d_1; V_1 = 0)$$

Table 4: Pass and Fail decision numbers of appendix 2 Sampling Plan

Minimum sample size: 3

Cumulative number of engines tested (sample size)	Pass decision number $A_n$	Fail decision number $B_n$
3	-0.80381	16.64743
4	-0.76339	7.68627
5	-0.72982	4.67136
6	-0.69962	3.25573
7	-0.67129	2.45431
8	-0.64406	1.94369
9	-0.61750	1.59105
10	-0.59135	1.33295
11	-0.56542	1.13566
12	-0.53960	0.97970
13	-0.51379	0.85307
14	-0.48791	0.74801
15	-0.46191	0.65928
16	-0.43573	0.58321
17	-0.40933	0.51718
18	-0.38266	0.45922
19	-0.35570	0.40788
20	-0.32840	0.36203
21	-0.30072	0.32078
22	-0.27263	0.28343
23	-0.24410	0.24943
24	-0.21509	0.21831
25	-0.18557	0.18970
26	-0.15550	0.16328
27	-0.12483	0.13880
28	-0.09354	0.11603
29	-0.06159	0.09480
30	-0.02892	0.07493
31	-0.00449	0.05629
32	0.03876	0.03876

Appendix 3

PROCEDURE FOR PRODUCTION CONFORMITY TESTING  
AT MANUFACTURER'S REQUEST

1. This appendix describes the procedure to be used to verify, at the manufacturer's request, production conformity for the emissions of pollutants.
2. With a minimum sample size of three engines, the sampling procedure is set so that the probability of a lot passing a test with 30 per cent of the engines defective is 0.90 (producer's risk = 10 per cent), while the probability of a lot being accepted with 65 per cent of the engines defective is 0.10 (consumer's risk = 10 per cent).
3. The following procedure is used for each of the pollutants given in Paragraph 5.2.1. of the Regulation (see figure 2):

Let:

$L$  = the limit value for the pollutant,

$x_i$  = the value of the measurement for the  $i$ -th engine of the sample,

$n$  = the current sample number.

4. Calculate for the sample the test statistic quantifying the number of non-conforming engines, i.e.  $x_i > L$ :
5. Then:
  - if the test statistic is less than or equal to the pass decision number for the sample size given in table 5, a pass decision is reached for the pollutant;
  - if the test statistic is greater than or equal to the fail decision number for the sample size given in table 5, a fail decision is reached for the pollutant;
  - otherwise, an additional engine is tested according to paragraph 8.4.2.1. of the Regulation and the calculation procedure is applied to the sample increased by one more unit.

In table 5 the pass and fail decision numbers are calculated by means of the International Standard ISO 8422:1991.

Table 5: Pass and Fail decision numbers of appendix 3 Sampling Plan

Minimum sample size: 3

Cumulative number of engines tested (sample size)	Pass decision number	Fail decision number
3	-	3
4	0	4
5	0	4
6	1	5
7	1	5
8	2	6
9	2	6
10	3	7
11	3	7
12	4	8
13	4	8
14	5	9
15	5	9
16	6	10
17	6	10
18	7	11
19	8	9

\_\_\_\_\_ "

Annex 1, amend to read:"Annex 1ESSENTIAL CHARACTERISTICS OF THE (PARENT) ENGINE AND INFORMATION CONCERNING THE CONDUCT OF TEST <sup>(1)</sup>

1. DESCRIPTION OF ENGINE
  - 1.1. Manufacturer: .....
  - 1.2. Manufacturer's engine code: .....
  - 1.3. Cycle: four stroke / two stroke<sup>(2)</sup>
  - 1.4. Number and arrangement of cylinders: .....
  - 1.4.1. Bore: ..... mm
  - 1.4.2. Stroke: ..... mm
  - 1.4.3. Firing order: .....
  - 1.5. Engine capacity: ..... cm<sup>3</sup>
  - 1.6. Volumetric compression ratio<sup>(3)</sup>: .....
  - 1.7. Drawing(s) of combustion chamber and piston crown: .....
  - 1.8. Minimum cross-sectional area of inlet and outlet ports: ..... cm<sup>2</sup>
  - 1.9. Idling speed: ..... min<sup>-1</sup>
  - 1.10. Maximum net power: .....kW at ..... min<sup>-1</sup>
  - 1.11. Maximum permitted engine speed: ..... min<sup>-1</sup>
  - 1.12. Maximum net torque: .....Nm at ..... min<sup>-1</sup>
  - 1.13. Combustion system: compression ignition/positive ignition<sup>(2)</sup>

- 1.14. Fuel: Diesel/LPG/NG-H/NG-L/NG-HL<sup>(2)</sup>
- 1.15. Cooling system
  - 1.15.1. Liquid
    - 1.15.1.1. Nature of liquid: .....
    - 1.15.1.2. Circulating pump(s): yes/no<sup>(2)</sup>
    - 1.15.1.3. Characteristics or make(s) and type(s) (if applicable): .....
    - 1.15.1.4. Drive ratio(s) (if applicable): .....
  - 1.15.2. Air
    - 1.15.2.1. Blower: yes/no<sup>(2)</sup>
    - 1.15.2.2. Characteristics or make(s) and type(s) (if applicable): .....
    - 1.15.2.3. Drive ratio(s) (if applicable): .....
- 1.16. Temperature permitted by the manufacturer
  - 1.16.1. Liquid cooling: Maximum temperature at outlet: .....K
  - 1.16.2. Air cooling: ..... Reference point: .....K
    - Maximum temperature at reference point: .....K
  - 1.16.3. Maximum temperature of the air at the outlet of the intake intercooler (if applicable) .....K
  - 1.16.4. Maximum exhaust temperature at the point in the exhaust pipe(s) adjacent to the outer flange(s) of the exhaust manifold(s) or turbocharger(s): .....K
  - 1.16.5. Fuel temperature: min. ....K, max. ....K for diesel engines at injection pump inlet, for gas fuelled engines at pressure regulator final stage.
  - 1.16.6. Fuel pressure: min. ....kPa, max. ....kPa at pressure regulator final stage, NG fuelled gas engines only.
  - 1.16.7. Lubricant temperature: min. ....K, max. ....K
- 1.17. Pressure charger: yes/no<sup>(2)</sup>
  - 1.17.1. Make: .....
  - 1.17.2. Type: .....
  - 1.17.3. ....Description of the system (e.g. max. charge pressure, wastegate, if applicable): .....
- 1.17.4. Intercooler: yes/no<sup>(2)</sup>
- 1.18. Intake system
  - Maximum allowable intake depression at rated engine speed and at 100 per cent load as specified in and under the operating conditions of Regulation No. 24 ..... kPa
- 1.19. Exhaust system
  - Maximum allowable exhaust back pressure at rated engine speed and at 100 per cent load as specified in and under the operating conditions of Regulation No. 24 ..... kPa
  - Exhaust system volume: ..... dm<sup>3</sup>
- 2. MEASURES TAKEN AGAINST AIR POLLUTION
  - 2.1. Device for recycling crankcase gases (description and drawings): ..
  - 2.2. Additional anti-pollution devices (if any, and if not covered by another heading)
    - 2.2.1. Catalytic converter: yes/no<sup>(2)</sup>
      - 2.2.1.1. Make(s): .....
      - 2.2.1.2. Type(s): .....
      - 2.2.1.3. Number of catalytic converters and elements:.....
      - 2.2.1.4. Dimensions, shape and volume of the catalytic converter(s): .....



- 2.2.1.5. Type of catalytic action: .....
- 2.2.1.6. Total charge of precious metals: .....
- 2.2.1.7. Relative concentration: .....
- 2.2.1.8. Substrate (structure and material): .....
- 2.2.1.9. Cell density: .....
- 2.2.1.10. Type of casing for the catalytic converter(s): .....
- 2.2.1.11. Location of the catalytic converter(s) (place and reference distance in the exhaust line): .....
- .....
- 2.2.2. Oxygen sensor: yes/no<sup>(2)</sup>
- 2.2.2.1. Make(s): .....
- 2.2.2.2. Type: .....
- 2.2.2.3. Location: .....
- 2.2.3. Air injection: yes/no<sup>(2)</sup>
- 2.2.3.1. Type (pulse air, air pump, etc.): .....
- 2.2.4. EGR: yes/no<sup>(2)</sup>
- 2.2.4.1. Characteristics (flow rate, etc.): .....
- 2.2.5. Particulate trap: yes/no<sup>(2)</sup>
- 2.2.5.1. Dimensions, shape and capacity of the particulate trap: .....
- 2.2.5.2. Type and design of the particulate trap: .....
- 2.2.5.3. Location (reference distance in the exhaust line): .....
- 2.2.5.4. Method or system of regeneration, description and/or drawing: .....
- 2.2.6. Other systems: yes/no<sup>(2)</sup>
- 2.2.6.1. Description and operation: .....

3. FUEL FEED

- 3.1. Diesel engines
- 3.1.1. Feed pump
- 3.1.1.1. Pressure<sup>(3)</sup> : .....kPa or characteristic diagram<sup>(2)</sup>:.....
- 3.1.2. Injection system
- 3.1.2.1. Pump
- 3.1.2.1.1. Make(s): .....
- 3.1.2.1.2. Type(s): .....
- 3.1.2.1.3. Delivery: .....mm<sup>3</sup><sup>(3)</sup> per stroke at engine speed of.....rpm at full injection, or characteristic diagram<sup>(2)</sup><sup>(3)</sup>: .....
- .....
- Mention the method used: On engine/on pump bench<sup>(2)</sup>
- If boost control is supplied, state the characteristic fuel delivery and boost pressure versus engine speed.
- 3.1.2.1.4. Injection advance
- 3.1.2.1.4.1. Injection advance curve<sup>(3)</sup>: .....
- 3.1.2.1.4.2. Static injection timing<sup>(3)</sup>: .....
- 3.1.2.2. Injection piping
- 3.1.2.2.1. Length: ..... mm
- 3.1.2.2.2. Internal diameter: ..... mm
- 3.1.2.3. Injector(s)
- 3.1.2.3.1. Make(s): .....
- 3.1.2.3.2. Type(s): .....
- 3.1.2.3.3. "Opening pressure": ..... kPa<sup>(3)</sup>
- or characteristic diagram<sup>(2)</sup><sup>(3)</sup>: .....
- 3.1.2.4. Governor
- 3.1.2.4.1. Make(s): .....
- 3.1.2.4.2. Type(s): .....
- 3.1.2.4.3. Speed at which cut-off starts under full load: ..... rpm

- 3.1.2.4.4. Maximum no-load speed: ..... rpm
- 3.1.2.4.5. Idling speed: ..... rpm
- 3.1.3. Cold start system
  - 3.1.3.1. Make(s): .....
  - 3.1.3.2. Type(s): .....
  - 3.1.3.3. Description: .....
  - 3.1.3.4. Auxiliary starting aid: .....
  - 3.1.3.4.1. Make: .....
  - 3.1.3.4.2. Type: .....
- 3.2. Gas fuelled engines<sup>(6)</sup>
  - 3.2.1. Fuel: Natural gas/LPG <sup>(2)</sup>
  - 3.2.2. Pressure regulator(s) or vaporiser/pressure regulator(s) <sup>(3)</sup>
    - 3.2.2.1. Make(s): .....
    - 3.2.2.2. Type(s): .....
    - 3.2.2.3. Number of pressure reduction stages: .....
    - 3.2.2.4. Pressure in final stage: min.....kPa, max. .... kPa
    - 3.2.2.5. Number of main adjustment points: .....
    - 3.2.2.6. Number of idle adjustment points: .....
    - 3.2.2.7. Approval number according to Reg. \*\*\*: .....
  - 3.2.3. Fuelling system: mixing unit / gas injection / liquid injection / direct injection<sup>(2)</sup>
    - 3.2.3.1. Mixture strength regulation: .....
    - 3.2.3.2. System description and/or diagram and drawings: .....
    - 3.2.3.3. Approval number according to Regulation No. ....
  - 3.2.4. Mixing unit
    - 3.2.4.1. Number: .....
    - 3.2.4.2. Make(s): .....
    - 3.2.4.3. Type(s): .....
    - 3.2.4.4. Location: .....
    - 3.2.4.5. Adjustment possibilities: .....
    - 3.2.4.6. Approval number according to Regulation No. ....
  - 3.2.5. Inlet manifold injection
    - 3.2.5.1. Injection: single point / multi-point <sup>(2)</sup>
    - 3.2.5.2. Injection : continuous / simultaneously timed / sequentially timed <sup>(2)</sup>
    - 3.2.5.3. Injection equipment
      - 3.2.5.3.1. Make(s): .....
      - 3.2.5.3.2. Type(s): .....
      - 3.2.5.3.3. Adjustment possibilities: .....
      - 3.2.5.3.4. Approval number according to Regulation No. ....
    - 3.2.5.4. Supply pump (if applicable): .....
    - 3.2.5.4.1. Make(s): .....
    - 3.2.5.4.2. Type(s): .....
    - 3.2.5.4.3. Approval number according to Regulation No. ....
  - 3.2.5.5. Injector(s): .....
  - 3.2.5.5.1. Make(s): .....
  - 3.2.5.5.2. Type(s): .....
  - 3.2.5.5.3. Approval number according to Regulation No. ....
- 3.2.6. Direct injection
  - 3.2.6.1. Injection pump / pressure regulator <sup>(2)</sup>
    - 3.2.6.1.1. Make(s): .....
    - 3.2.6.1.2. Type(s): .....
    - 3.2.6.1.3. Injection timing: .....
    - 3.2.6.1.4. Approval number according to Regulation No. ....
  - 3.2.6.2. Injector(s)
    - 3.2.6.2.1. Make(s): .....

- 3.2.6.2.2. Type(s): .....
- 3.2.6.2.3. Opening pressure or characteristic diagram <sup>(3)</sup>: .....
- 3.2.6.2.4. Approval number according to Regulation No. ....
- 3.2.7. Electronic control unit (ECU)
- 3.2.7.1. Make(s): .....
- 3.2.7.2. Type(s): .....
- 3.2.7.3. Adjustment possibilities: .....
- 3.2.8. NG fuel-specific equipment
- 3.2.8.1. Variant 1 (only in the case of approvals of engines for several specific fuel compositions)
- 3.2.8.1.1. Fuel composition:

methane (CH <sub>4</sub> ):	basis:....%mole	min.....%mole	max.....%mole
ethane (C <sub>2</sub> H <sub>6</sub> ):	basis:....%mole	min.....%mole	max.....%mole
propane (C <sub>3</sub> H <sub>8</sub> ):	basis:....%mole	min.....%mole	max.....%mole
butane (C <sub>4</sub> H <sub>10</sub> ):	basis:....%mole	min.....%mole	max.....%mole
C5/C5+:	basis:....%mole	min.....%mole	max.....%mole
oxygen (O <sub>2</sub> ):	basis:....%mole	min.....%mole	max.....%mole
inert (N <sub>2</sub> , He etc):	basis:....%mole	min.....%mole	max.....%mole

- 3.2.8.1.2. Injector(s)
- 3.2.8.1.2.1. Make(s):
- 3.2.8.1.2.2. Type(s):
- 3.2.8.1.3. Others (if applicable)
- 3.2.8.2. Variant 2 (only in the case of approvals for several specific fuel compositions)

4. VALVE TIMING

- 4.1. Maximum lift of valves and angles of opening and closing in relation to dead centres or equivalent data .....
- 4.2. Reference and/or setting ranges <sup>(2)</sup> : .....

5. IGNITION SYSTEM (SPARK IGNITION ENGINES ONLY)

- 5.1. Ignition system type:
  - common coil and plugs / individual coil and plugs / coil on plug / other (specify) <sup>(2)</sup>
- 5.2. Ignition control unit
  - 5.2.1. Make(s): .....
  - 5.2.2. Type(s): .....
- 5.3. Ignition advance curve / advance map <sup>(2)</sup> <sup>(3)</sup> : .....
- 5.4. Ignition timing <sup>(3)</sup>: ...degrees before TDC at a speed of ..... rpm and a MAP of ..... kPa
- 5.5. Spark plugs
  - 5.5.1. Make(s): .....
  - 5.5.2. Type(s): .....
  - 5.5.3. Gap setting: .....mm
- 5.6. Ignition coil(s)
  - 5.6.1. Make(s): .....
  - 5.6.2. Type(s): .....

6. ENGINE-DRIVEN EQUIPMENT

The engine must be submitted for testing with the auxiliaries needed for operating the engine (e.g. fan, water pump, etc.), as specified in and under the operating conditions of Regulation No. 24.

6.1. Auxiliaries to be fitted for the test

If it is impossible or inappropriate to install the auxiliaries on the test bench, the power absorbed by them must be determined and subtracted from the measured engine power over the whole operating area of the test cycle(s).

6.2. Auxiliaries to be removed for the test

Auxiliaries needed only for the operation of the vehicle (e.g. air compressor, air-conditioning system etc.) must be removed for the test. Where the auxiliaries cannot be removed, the power absorbed by them may be determined and added to the measured engine power over the whole operating area of the test cycle(s).

7. ADDITIONAL INFORMATION ON TEST CONDITIONS

7.1. Lubricant used

7.1.1. Make: .....

7.1.2. Type: .....

(State percentage of oil in mixture if lubricant and fuel are mixed):

.....

7.2. Engine-driven equipment (if applicable)

The power absorbed by the auxiliaries needs only be determined,

- if auxiliaries needed for operating the engine, are not fitted to the engine and/or

- if auxiliaries not needed for operating the engine, are fitted to the engine.

7.2.1. Enumeration and identifying details: .....

7.2.2. Power absorbed at various indicated engine speeds:

Equipment	Power absorbed (kW) at various engine speeds						
	Idle	Low Speed	High Speed	Speed A <sup>(7)</sup>	Speed B <sup>(7)</sup>	Speed C <sup>(7)</sup>	Ref. Speed <sup>(8)</sup>
P(a) Auxiliaries needed for operating the engine (to be subtracted from measured engine power) see item 6.1.							
P(b) Auxiliaries not needed for operating the engine (to be added to measured engine power) see item 6.2.							

8. ENGINE PERFORMANCE

8.1. Engine speeds <sup>(9)</sup>

Low speed ( $n_{lo}$ ): .....rpm  
 High speed ( $n_{hi}$ ): .....rpm

for ESC and ELR Cycles

Idle: .....rpm

Speed A: .....rpm

Speed B: .....rpm

Speed C: .....rpm

for ETC cycle

Reference speed: .....rpm

8.2. Engine power (measured in accordance with the provisions of Regulation No. 24) in kW

	Engine speed				
	Idle	Speed A <sup>(7)</sup>	Speed B <sup>(7)</sup>	Speed C <sup>(7)</sup>	Ref. Speed <sup>(8)</sup>
P(m) Power measured on test bed					
P(a) Power absorbed by auxiliaries to be fitted for test (item 6.1) - if fitted - if not fitted	0	0	0	0	0
P(b) Power absorbed by auxiliaries to be removed for test (item 6.2) - if fitted - if not fitted	0	0	0	0	0
P(n) Net engine power = P(m) - P(a) + P(b)					

8.3. Dynamometer settings (kW)

The dynamometer settings for the ESC and ELR tests and for the reference cycle of the ETC test must be based upon the net engine power P(n) of paragraph 8.2. It is recommended to install the engine on the test bed in the net condition. In this case, P(m) and P(n) are identical. If it is impossible or inappropriate to operate the engine under net conditions, the dynamometer settings must be corrected to net conditions using the above formula.

8.3.1. ESC and ELR Tests

The dynamometer settings must be calculated according to the formula in annex 4, appendix 1, paragraph 1.2.

Per cent load	Engine speed			
	Idle	Speed A	Speed B	Speed C
10	--			
25	--			
50	--			
75	--			
100				

8.3.2. ETC Test

If the engine is not tested under net conditions, the correction formula for converting the measured power or measured cycle work, as determined according to annex 4, appendix 2, paragraph 2., to net power or net cycle work must be submitted by the engine manufacturer for the whole operating area of the cycle, and approved by the Technical Service.

Footnotes:

- (1) In the case of non-conventional engines and systems, particulars equivalent to those referred to here must be supplied by the manufacturer.
- (2) Strike out what does not apply.
- (3) Specify the tolerance.
- (6) In the case of systems laid out in a different manner, supply equivalent information (for paragraph 3.2).
- (7) ESC test
- (8) ETC test only.
- (9) Specify the tolerance; to be within  $\pm 3$  per cent of the values declared by the manufacturer.

\_\_\_\_\_ "

Annex 1 - Appendix, rename as annex 1 - appendix 1, and amend to read:

"Annex 1 - Appendix 1

CHARACTERISTICS OF THE ENGINE-RELATED VEHICLE PARTS

1. Intake system depression at rated engine speed and at 100 per cent load: .....kPa
2. Exhaust system back pressure at rated engine speed and at 100 per cent load: .....kPa
3. Volume of exhaust system: .....cm<sup>3</sup>
4. Power absorbed by the auxiliaries needed for operating the engine as specified in and under the operation conditions of Regulation No. 24

Equipment	Power absorbed (kW) at various engine speeds						
	Idle	Low Speed	High Speed	Speed A <sup>(1)</sup>	Speed B <sup>(1)</sup>	Speed C <sup>(1)</sup>	Ref. Speed <sup>(2)</sup>
P(a) Auxiliaries needed for operating the engine (to be subtracted from measured engine power) see annex 1, item 6.1.							

(1) ESC test

(2) ETC test only.

=====

Insert new Annex 1 - Appendices 2 and 3, to read:

"Annex 1 - Appendix 2

ESSENTIAL CHARACTERISTICS OF THE ENGINE FAMILY

1. COMMON PARAMETERS
  - 1.1. Combustion cycle: .....
  - 1.2. Cooling medium: .....
  - 1.3. Number of cylinders<sup>(1)</sup>.....
  - 1.4. Individual cylinder displacement: .....
  - 1.5. Method of air aspiration: .....
  - 1.6. Combustion chamber type/design: .....

- 1.7. Valve and porting - configuration, size and number: .....
- 1.8. Fuel system: .....
- 1.9. Ignition system (gas engines): .....
- 1.10. Miscellaneous features:
  - charge cooling system <sup>(1)</sup>: .....
  - exhaust gas recirculation <sup>(1)</sup>: .....
  - water injection/emulsion <sup>(1)</sup>: .....
  - air injection <sup>(1)</sup>: .....
- 1.11. Exhaust after-treatment <sup>(1)</sup>: .....

Proof of identical (or lowest for the parent engine) ratio:  
system capacity / fuel delivery per stroke, pursuant to  
diagram number(s): .....

2. ENGINE FAMILY LISTING

- 2.1. Name of diesel engine family: .....
- 2.1.1. Specification of engines within this family:

					Parent Engine
Engine Type					
No. of cylinders					
Rated speed (rpm)					
Fuel delivery per stroke (mm <sup>3</sup> )					
Rated net power (kW)					
Maximum torque speed (rpm)					
Fuel delivery per stroke (mm <sup>3</sup> )					
Maximum torque (Nm)					
Low idle speed (rpm)					
Cylinder displacement (in % of parent engine)					100



2.2. Name of gas engine family: .....

2.2.1 Specification of engines within this family:

					Parent Engine
Engine Type					
No. of cylinders					
Rated speed (rpm)					
Fuel delivery per stroke (mg)					
Rated net power (kW)					
Maximum torque speed (rpm)					
Fuel delivery per stroke (mm <sup>3</sup> )					
Maximum torque (Nm)					
Low idle speed (rpm)					
Cylinder displacement (in % of parent engine)					100
Spark timing					
EGR flow					
Air pump yes / no					
Air pump actual flow					

(1) If not applicable, mark "N/A"

Annex 1 - Appendix 3

ESSENTIAL CHARACTERISTICS OF THE ENGINE TYPE  
WITHIN THE FAMILY <sup>(1)</sup>

1. DESCRIPTION OF ENGINE
  - 1.1. Manufacturer: .....
  - 1.2. Manufacturer's engine code: .....
  - 1.3. Cycle: four stroke / two stroke <sup>(2)</sup>
  - 1.4. Number and arrangement of cylinders: .....
  - 1.4.1. Bore: .....mm
  - 1.4.2. Stroke: .....mm
  - 1.4.3. Firing order: .....
  - 1.5. Engine capacity: .....cm<sup>3</sup>
  - 1.6. Volumetric compression ratio <sup>(3)</sup>: .....
  - 1.7. Drawing(s) of combustion chamber and piston crown: .....
  - 1.8. Minimum cross-sectional area of inlet and outlet ports: .....cm<sup>2</sup>
  - 1.9. Idling speed: .....min<sup>-1</sup>
  - 1.10. Maximum net power: .....kW at .....min<sup>-1</sup>
  - 1.11. Maximum permitted engine speed: .....min<sup>-1</sup>
  - 1.12. Maximum net torque: .....Nm at .....min<sup>-1</sup>

- 1.13. Combustion system: compression ignition/positive ignition <sup>(2)</sup>
- 1.14. Fuel: Diesel/LPG/NG-H/NG-L/NG-HL <sup>(2)</sup>
- 1.15. Cooling system
  - 1.15.1. Liquid
    - 1.15.1.1. Nature of liquid: .....
    - 1.15.1.2. Circulating pump(s): yes/no <sup>(2)</sup>
    - 1.15.1.3. Characteristics or make(s) and type(s) (if applicable): .....
    - 1.15.1.4. Drive ratio(s) (if applicable): .....
  - 1.15.2. Air
    - 1.15.2.1. Blower: yes/no <sup>(2)</sup>
    - 1.15.2.2. Characteristics or make(s) and type(s) (if applicable): .....
    - 1.15.2.3. Drive ratio(s) (if applicable): .....
- 1.16. Temperature permitted by the manufacturer
  - 1.16.1. Liquid cooling: Maximum temperature at outlet: .....K
  - 1.16.2. Air cooling: Reference point: .....K  
Maximum temperature at reference point: .....K
  - 1.16.3. Maximum temperature of the air at the outlet of the intake intercooler (if applicable): .....K
  - 1.16.4. Maximum exhaust temperature at the point in the exhaust pipe(s) adjacent to the outer flange(s) of the exhaust manifold(s) or turbocharger(s): .....K
  - 1.16.5. Fuel temperature: min. ....K, max. ....K  
for diesel engines at injection pump inlet, for NG fuelled gas engines at pressure regulator final stage
  - 1.16.6. Fuel pressure: min. ....kPa, max. ....kPa  
at pressure regulator final stage, NG fuelled gas engines only
  - 1.16.7. Lubricant temperature: min. ....K, max. ....K
- 1.17. Pressure charger: yes/no <sup>(2)</sup>
  - 1.17.1. Make: .....
  - 1.17.2. Type: .....
  - 1.17.3. Description of the system (e.g. max. charge pressure, wastegate, if applicable): .....
  - 1.17.4. Intercooler: yes/no <sup>(2)</sup>
- 1.18. Intake system  
Maximum allowable intake depression at rated engine speed and at 100 per cent load as specified in and under the operating conditions of Regulation No. 24: .....kPa
- 1.19. Exhaust system  
Maximum allowable exhaust back pressure at rated engine speed and at 100 per cent load as specified in and under the operating conditions of Regulation No. 24: .....kPa  
Exhaust system volume: .....cm<sup>3</sup>
- 2. MEASURES TAKEN AGAINST AIR POLLUTION
  - 2.1. Device for recycling crankcase gases (description and drawings): .....
  - 2.2. Additional anti-pollution devices (if any, and if not covered by another heading)
    - 2.2.1. Catalytic converter: yes/no <sup>(2)</sup>
      - 2.2.1.1. Number of catalytic converters and elements: .....
      - 2.2.1.2. Dimensions, shape and volume of the catalytic converter(s): .....
      - 2.2.1.3. Type of catalytic action: .....

- 2.2.1.4. Total charge of precious metals: .....
- 2.2.1.5. Relative concentration: .....
- 2.2.1.6. Substrate (structure and material): .....
- 2.2.1.7. Cell density: .....
- 2.2.1.8. Type of casing for the catalytic converter(s): .....
- 2.2.1.9. Location of the catalytic converter(s) (place and reference distance in the exhaust line): .....
- .....
- 2.2.2. Oxygen sensor: yes/no <sup>(2)</sup>
- 2.2.2.1. Type: .....
- 2.2.3. Air injection: yes/no <sup>(2)</sup>
- 2.2.3.1. Type (pulse air, air pump, etc.): .....
- 2.2.4. EGR: yes/no <sup>(2)</sup>
- 2.2.4.1. Characteristics (flow rate etc.): .....
- 2.2.5. Particulate trap: yes/no <sup>(2)</sup>
- 2.2.5.1. Dimensions, shape and capacity of the particulate trap: .....
- .....
- 2.2.5.2. Type and design of the particulate trap: .....
- 2.2.5.3. Location (reference distance in the exhaust line): .....
- 2.2.5.4. Method or system of regeneration, description and/or drawing: ...
- .....
- 2.2.6. Other systems: yes/no <sup>(2)</sup>
- 2.2.6.1. Description and operation: .....
- 3. FUEL FEED
- 3.1. Diesel engines
- 3.1.1. Feed pump
- 3.1.1.1. Pressure <sup>(3)</sup>: .....kPa or characteristic diagram <sup>(2)</sup>: ....
- .....
- 3.1.2. Injection system
- 3.1.2.1. Pump
- 3.1.2.1.1. Make(s): .....
- 3.1.2.1.2. Type(s): .....
- 3.1.2.1.3. Delivery: .....mm<sup>3</sup> <sup>(3)</sup> per stroke at engine speed of.....rpm at full injection, or characteristic diagram <sup>(2)</sup> <sup>(3)</sup>: .....
- .....
- Mention the method used: On engine / on pump bench <sup>(2)</sup>
- If boost control is supplied, state the characteristic fuel delivery and boost pressure versus engine speed.
- 3.1.2.1.4. Injection advance
- 3.1.2.1.4.1. Injection advance curve <sup>(3)</sup>: .....
- 3.1.2.1.4.2. Static injection timing <sup>(3)</sup>: .....
- 3.1.2.2. Injection piping
- 3.1.2.2.1. Length: .....mm
- 3.1.2.2.2. Internal diameter: .....mm
- 3.1.2.3. Injector(s)
- 3.1.2.3.1. Make(s): .....
- 3.1.2.3.2. Type(s): .....
- 3.1.2.3.3. "Opening pressure": .....kPa <sup>(3)</sup> or characteristic diagram <sup>(2)</sup> <sup>(3)</sup>: .....
- 3.1.2.4. Governor
- 3.1.2.4.1. Make(s): .....
- 3.1.2.4.2. Type(s): .....
- 3.1.2.4.3. Speed at which cut-off starts under full load: .....rpm

- 3.1.2.4.4. Maximum no-load speed: .....rpm
- 3.1.2.4.5. Idling speed: .....rpm
- 3.1.3. Cold start system
  - 3.1.3.1. Make(s): .....
  - 3.1.3.2. Type(s): .....
  - 3.1.3.3. Description: .....
  - 3.1.3.4. Auxiliary starting aid: .....
  - 3.1.3.4.1. Make: .....
  - 3.1.3.4.2. Type: .....
- 3.2. Gas fuelled engines
  - 3.2.1. Fuel: Natural gas/LPG <sup>(2)</sup>
  - 3.2.2. Pressure regulator(s) or vaporiser/pressure regulator(s) <sup>(2)</sup>
    - 3.2.2.1. Make(s): .....
    - 3.2.2.2. Type(s): .....
    - 3.2.2.3. Number of pressure reduction stages: .....
    - 3.2.2.4. Pressure in final stage: min. ....kPa, max. ....kPa
    - 3.2.2.5. Number of main adjustment points: .....
    - 3.2.2.6. Number of idle adjustment points: .....
    - 3.2.2.7. Approval number: .....
  - 3.2.3. Fuelling system: mixing unit / gas injection / liquid injection / direct injection <sup>(2)</sup>
    - 3.2.3.1. Mixture strength regulation: .....
    - 3.2.3.2. System description and/or diagram and drawings: .....
    - 3.2.3.3. Approval number: .....
  - 3.2.4. Mixing unit
    - 3.2.4.1. Number: .....
    - 3.2.4.2. Make(s): .....
    - 3.2.4.3. Type(s): .....
    - 3.2.4.4. Location: .....
    - 3.2.4.5. Adjustment possibilities: .....
    - 3.2.4.6. Approval number: .....
  - 3.2.5. Inlet manifold injection
    - 3.2.5.1. Injection: single point / multi-point <sup>(2)</sup>
    - 3.2.5.2. Injection : continuous / simultaneously timed / sequentially timed <sup>(2)</sup>
    - 3.2.5.3. Injection equipment
      - 3.2.5.3.1. Make(s): .....
      - 3.2.5.3.2. Type(s): .....
      - 3.2.5.3.3. Adjustment possibilities: .....
      - 3.2.5.3.4. Approval number: .....
    - 3.2.5.4. Supply pump (if applicable): .....
    - 3.2.5.4.1. Make(s): .....
    - 3.2.5.4.2. Type(s): .....
    - 3.2.5.4.3. Approval number: .....
    - 3.2.5.5. Injector(s):.....
      - 3.2.5.5.1. Make(s): .....
      - 3.2.5.5.2. Type(s): .....
      - 3.2.5.5.3. Approval number: .....
  - 3.2.6. Direct injection
    - 3.2.6.1. Injection pump / pressure regulator <sup>(2)</sup>
      - 3.2.6.1.1. Make(s): .....
      - 3.2.6.1.2. Type(s): .....
      - 3.2.6.1.3. Injection timing: .....
      - 3.2.6.1.4. Approval number: .....
    - 3.2.6.2. Injector(s)

- 3.2.6.2.1. Make(s): .....
- 3.2.6.2.2. Type(s): .....
- 3.2.6.2.3. Opening pressure or characteristic diagram <sup>(3)</sup>: .....
- 3.2.6.2.4. Approval number: .....
- 3.2.7. Electronic control unit (ECU)
- 3.2.7.1. Make(s): .....
- 3.2.7.2. Type(s): .....
- 3.2.7.3. Adjustment possibilities: .....
- 3.2.8. NG fuel-specific equipment
- 3.2.8.1. Variant 1 (only in the case of approvals of engines for several specific fuel compositions)
- 3.2.8.1.1. Fuel composition:
- |   |                 |               |               |
|---|-----------------|---------------|---------------|
| methane (CH <sub>4</sub> ):               | basis:....%mole | min.....%mole | max.....%mole |
| ethane (C <sub>2</sub> H <sub>6</sub> ):  | basis:....%mole | min.....%mole | max.....%mole |
| propane (C <sub>3</sub> H <sub>8</sub> ): | basis:....%mole | min.....%mole | max.....%mole |
| butane (C <sub>4</sub> H <sub>10</sub> ): | basis:....%mole | min.....%mole | max.....%mole |
| C5/C5+:                                   | basis:....%mole | min.....%mole | max.....%mole |
| oxygen (O <sub>2</sub> ):                 | basis:....%mole | min.....%mole | max.....%mole |
| inert (N <sub>2</sub> , He etc):          | basis:....%mole | min.....%mole | max.....%mole |
- 3.2.8.1.2. Injector(s)
- 3.2.8.1.2.1. Make(s): .....
- 3.2.8.1.2.2. Type(s): .....
- 3.2.8.1.3. Others (if applicable)
- 3.2.8.2. Variant 2 (only in the case of approvals for several specific fuel compositions)
4. VALVE TIMING
- 4.1. Maximum lift of valves and angles of opening and closing in relation to dead centres of equivalent data: .....
- 4.2. Reference and/or setting ranges <sup>(2)</sup>: .....
5. IGNITION SYSTEM (SPARK IGNITION ENGINES ONLY)
- 5.1. Ignition system type: common coil and plugs / individual coil and plugs / coil on plug / other (specify) <sup>(2)</sup>
- 5.2. Ignition control unit
- 5.2.1. Make(s): .....
- 5.2.2. Type(s): .....
- 5.2. Ignition advance curve / advance map <sup>(2)(3)</sup>: .....
- 5.4. Ignition timing <sup>(3)</sup>: .....degrees before TDC at a speed of ..... rpm and a MAP of ..... kPa
- 5.5. Spark plugs
- 5.5.1. Make(s): .....
- 5.5.2. Type(s): .....
- 5.5.3. Gap setting: .....mm
- 5.6. Ignition coil(s)
- 5.6.1. Make(s): .....
- 5.6.2. Type(s): .....

Footnotes

- (1) To be submitted for each engine of the family.  
(2) Strike out what does not apply.  
(3) Specify the tolerance.

\_\_\_\_\_ "

Annex 3, amend to read:

"Annex 3

ARRANGEMENTS OF APPROVAL MARKS  
(See paragraph 4.6. of this Regulation)

- I. APPROVAL "I" (Row A).  
(See paragraph 4.6.3. of this Regulation)

Model A

Engines approved to Row A emission limits and operating on diesel or liquefied petroleum gas (LPG) fuel.



a = 8 mm min.

Model B

Engines approved to Row A emission limits and operating on natural gas (NG) fuel. The suffix after the national symbol indicates the fuel qualification determined in accordance with paragraph 4.6.3.1. of this Regulation.

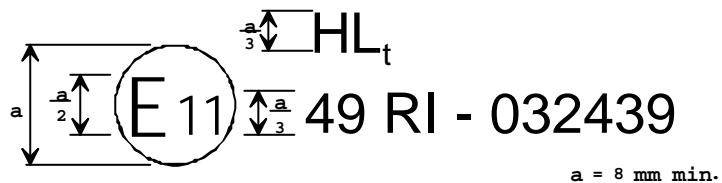

a = 8 mm min.

The above approval marks affixed to an engine/vehicle show that the engine/vehicle type concerned has been approved in the United Kingdom (E11) pursuant to Regulation No. 49 and under approval number 032439. This approval indicates that the approval was given in accordance with the requirements of Regulation No. 49 with the 03 series of amendments incorporated and satisfying the relevant limits detailed in paragraph 5.2.1. of this Regulation.

- II. APPROVAL "II" (Row B1).  
 (See paragraph 4.6.3. of this Regulation)

Model C

Engines approved to Row B1 emission limits and operating on diesel or liquefied petroleum gas (LPG) fuel.



Model D

Engines approved to Row B1 emission limits and operating on natural gas (NG) fuel. The suffix after the national symbol indicates the fuel qualification determined in accordance with paragraph 4.6.3.1. of this Regulation.

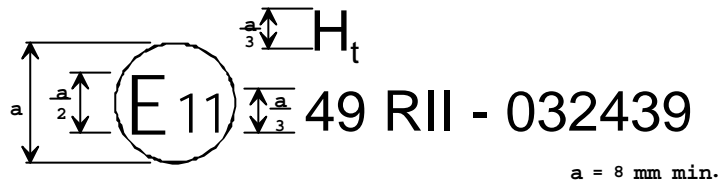

The above approval mark affixed to an engine/vehicle shows that the engine/vehicle type concerned has been approved in the United Kingdom (E11) pursuant to Regulation No. 49 and under approval number 032439. This approval indicates that the approval was given in accordance with the requirements of Regulation No. 49 with the 03 series of amendments incorporated and satisfying the relevant limits detailed in paragraph 5.2.1. of this Regulation.

- III. APPROVAL "III" (Row B2).  
 (See paragraph 4.6.3. of this Regulation)

Model E

Engines approved to Row B2 emission limits and operating on diesel or liquefied petroleum gas (LPG) fuel.



Model F

Engines approved to Row B2 emission limits and operating on natural gas (NG) fuel. The suffix after the national symbol indicates the fuel qualification determined in accordance with paragraph 4.6.3.1. of this Regulation.



The above approval mark affixed to an engine/vehicle shows that the engine/vehicle type concerned has been approved in the United Kingdom (E11) pursuant to Regulation No. 49 and under approval number 032439. This approval indicates that the approval was given in accordance with the requirements of Regulation No. 49 with the 03 series of amendments incorporated and satisfying the relevant limits detailed in paragraph 5.2.1. of this Regulation.

- IV. APPROVAL "IV" (Row C).  
(See paragraph 4.6.3. of this Regulation)

Model G

Engines approved to Row C emission limits and operating on diesel or liquefied petroleum gas (LPG) fuel.



Model H

Engines approved to Row C emission limits and operating on natural gas (NG) fuel. The suffix after the national symbol indicates the fuel qualification determined in accordance with paragraph 4.6.3.1. of this Regulation.

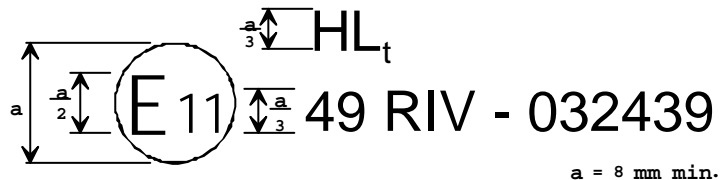

The above approval mark affixed to an engine/vehicle shows that the engine/vehicle type concerned has been approved in the United Kingdom



(E11) pursuant to Regulation No. 49 and under approval number 032439. This approval indicates that the approval was given in accordance with the requirements of Regulation No. 49 with the 03 series of amendments incorporated and satisfying the relevant limits detailed in paragraph 5.2.1. of this Regulation.

V. ENGINE/VEHICLE APPROVED TO ONE OR MORE REGULATIONS

(See paragraph 4.7. of this Regulation)

Model I

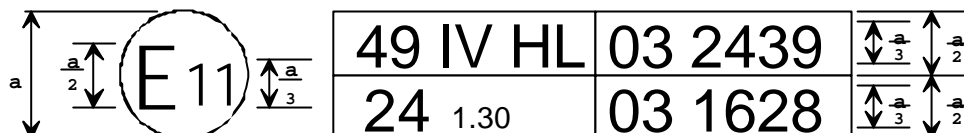

The above approval mark affixed to an engine/vehicle shows that the engine/vehicle type concerned has been approved in the United Kingdom (E11) pursuant to Regulation No. 49 (emission level IV) and Regulation No. 24. The first two digits of the approval numbers indicate that, at the dates when the respective approvals were given, Regulation No. 49 included the 03 series of amendments, as did Regulation No. 24.

<sup>1/</sup> The second Regulation number is given merely as an example; the corrected absorption coefficient is 1.30 m<sup>-1</sup>.

Annex 4, amend to read:

"Annex 4

TEST PROCEDURE

1. INTRODUCTION

1.1. This annex describes the methods of determining emissions of gaseous components, particulates and smoke from the engines to be tested. Three test cycles are described that must be applied according to the provisions of the Regulation, paragraph 6.2:

1.1.1. the ESC which consists of a steady state 13-mode cycle,

1.1.2. the ELR which consists of transient load steps at different speeds, which are integral parts of one test procedure, and are run concurrently;

1.1.3. the ETC which consists of a second-by-second sequence of transient modes.

1.2. The test must be carried out with the engine mounted on a test bench and connected to a dynamometer.

1.3. Measurement principle

The emissions to be measured from the exhaust of the engine include the gaseous components (carbon monoxide, total hydrocarbons for diesel engines on the ESC test only; non-methane hydrocarbons for diesel and gas engines on the ETC test only; methane for gas engines on the ETC test only and oxides of nitrogen), the particulates (diesel engines only) and smoke (diesel engines on the ELR test only). Additionally, carbon dioxide is often used as a tracer gas for determining the dilution ratio of partial and full flow dilution systems. Good engineering practice recommends the general measurement of carbon dioxide as an excellent tool for the detection of measurement problems during the test run.

1.3.1. ESC test

During a prescribed sequence of warmed-up engine operating conditions the amounts of the above exhaust emissions must be examined continuously by taking a sample from the raw exhaust gas. The test cycle consists of a number of speed and power modes, which cover the typical operating range of diesel engines. During each mode the concentration of each gaseous pollutant, exhaust flow and power output must be determined, and the measured values weighted. The particulate sample must be diluted with conditioned ambient air. One sample over the complete test procedure must be taken, and collected on suitable filters. The grams of each pollutant emitted per kilowatt-hour (kWh) must be calculated as described in appendix 1 to this annex. Additionally, NO<sub>x</sub> must be measured at three test points within the control area selected by the Technical Service <sup>1</sup> and the measured values compared to the values calculated from those modes of the test cycle enveloping the selected test points. The NO<sub>x</sub> control check ensures the effectiveness of the emission control of the engine within the typical engine operating range.

1.3.2. ELR test

During a prescribed load response test, the smoke of a warmed-up engine must be determined by means of an opacimeter. The test consists of loading the engine at constant speed from 10 per cent to 100 per cent load at three different engine speeds. Additionally, a fourth load step selected by the Technical Service <sup>1</sup> must be run, and the value compared to the values of the previous load steps. The smoke peak must be determined using an averaging algorithm, as described in appendix 1 to this annex.

1.3.3. ETC test

During a prescribed transient cycle of warmed-up engine operating conditions, which is based closely on road-type-specific driving patterns of heavy-duty engines installed in trucks and buses, the above

---

<sup>1</sup> The test points must be selected using approved statistical methods of randomisation.

pollutants must be examined after diluting the total exhaust gas with conditioned ambient air. Using the engine torque and speed feedback signals of the engine dynamometer, the power must be integrated with respect to time of the cycle resulting in the work produced by the engine over the cycle. The concentration of NO<sub>x</sub> and HC must be determined over the cycle by integration of the analyser signal. The concentration of CO, CO<sub>2</sub>, and NMHC may be determined by integration of the analyser signal or by bag sampling. For particulates, a proportional sample must be collected on suitable filters. The diluted exhaust gas flow rate must be determined over the cycle to calculate the mass emission values of the pollutants. The mass emission values must be related to the engine work to get the grams of each pollutant emitted per kilowatt-hour (kWh), as described in appendix 2 to this annex.

## 2. TEST CONDITIONS

### 2.1. Engine test conditions

2.1.1. The absolute temperature ( $T_a$ ) of the engine air at the inlet to the engine expressed in Kelvins, and the dry atmospheric pressure ( $p_s$ ), expressed in kPa must be measured and the parameter F must be determined according to the following provisions:

(a) for diesel engines:

Naturally aspirated and mechanically supercharged engines:

$$F = \left( \frac{99}{p_s} \right) * \left( \frac{T_a}{298} \right)^{0.7}$$

Turbocharged engines with or without cooling of the intake air:

$$F = \left( \frac{99}{p_s} \right)^{0.7} * \left( \frac{T_a}{298} \right)^{1.5}$$

(b) for gas engines:

$$F = \left( \frac{99}{p_s} \right)^{1.2} * \left( \frac{T_a}{298} \right)^{0.6}$$

### 2.1.2. Test validity

For a test to be recognised as valid, the parameter F must be such that:

$$0.96 \leq F \leq 1.06$$

2.2. Engines with charge air cooling

The charge air temperature must be recorded and must be, at the speed of the declared maximum power and full load, within  $\pm 5$  K of the maximum charge air temperature specified in annex 1, appendix 1, paragraph 1.16.3. The temperature of the cooling medium must be at least 293 K (20°C).

If a test shop system or external blower is used, the charge air temperature must be within  $\pm 5$  K of the maximum charge air temperature specified in annex 1, appendix 1, paragraph 1.16.3. at the speed of the declared maximum power and full load. The setting of the charge air cooler for meeting the above conditions must be used for the whole test cycle.

2.3. Engine air intake system

An engine air intake system must be used presenting an air intake restriction within  $\pm 100$  Pa of the upper limit of the engine operating at the speed at the declared maximum power and full load.

2.4. Engine exhaust system

An exhaust system must be used presenting an exhaust back pressure within  $\pm 1000$  Pa of the upper limit of the engine operating at the speed of declared maximum power and full load and a volume within  $\pm 40$  per cent of that specified by the manufacturer. A test shop system may be used, provided it represents actual engine operating conditions. The exhaust system must conform to the requirements for exhaust gas sampling, as set out in annex 4, appendix 4, paragraph 3.4. and in annex 4, appendix 7, paragraph 2.2.1., EP and paragraph 2.3.1., EP.

If the engine is equipped with an exhaust after-treatment device, the exhaust pipe must have the same diameter as found in-use for at least 4 pipe diameters upstream to the inlet of the beginning of the expansion paragraph containing the after-treatment device. The distance from the exhaust manifold flange or turbocharger outlet to the exhaust after-treatment device must be the same as in the vehicle configuration or within the distance specifications of the manufacturer. The exhaust back-pressure or restriction must follow the same criteria as above, and may be set with a valve. The after-treatment container may be removed during dummy tests and during engine mapping, and replaced with an equivalent container having an inactive catalyst support.

2.5. Cooling system

An engine cooling system with sufficient capacity to maintain the engine at normal operating temperatures prescribed by the manufacturer must be used.

2.6 Lubricating oil

Specifications of the lubricating oil used for the test must be recorded and presented with the results of the test, as specified in annex 1, appendix 1, paragraph 7.1.

## 2.7. Fuel

The fuel must be the reference fuel specified in annexes 5, 5 or 7.

The fuel temperature and measuring point must be specified by the manufacturer within the limits given in annex 1, appendix 1, paragraph 1.16.5. The fuel temperature must not be lower than 306 K (33°C). If not specified, it must be 311 K  $\pm$  5 K (38°C  $\pm$  5°C) at the inlet to the fuel supply.

For NG and LPG fuelled engines, the fuel temperature and measuring point must be within the limits given in annex 1, appendix 1, paragraph 1.16.5. or in annex 1, appendix 3, paragraph 1.16.5. in cases where the engine is not a parent engine.

## 2.8. Testing of exhaust after-treatment systems

If the engine is equipped with an exhaust after-treatment system, the emissions measured on the test cycle(s) must be representative of the emissions in the field. If this cannot be achieved with one single test cycle (e.g. for particulate filters with periodic regeneration), several test cycles must be conducted and the test results averaged and/or weighted. The exact procedure must be agreed by the engine manufacturer and the Technical Service based upon good engineering judgement.

\_\_\_\_\_ "

Annex 4 - Appendix 1, amend to read:

### "Annex 4 - Appendix 1

#### ESC AND ELR TEST CYCLES

### 1. ENGINE AND DYNAMOMETER SETTINGS

#### 1.1. Determination of engine speeds A, B and C

The engine speeds A, B and C must be declared by the manufacturer in accordance with the following provisions:

The high speed  $n_{hi}$  must be determined by calculating 70 per cent of the declared maximum net power  $P(n)$ , as determined in annex 1, appendix 1, paragraph 8.2. The highest engine speed where this power value occurs on the power curve is defined as  $n_{hi}$ .

The low speed  $n_{lo}$  must be determined by calculating 50 per cent of the declared maximum net power  $P(n)$ , as determined in annex 1, appendix 1, paragraph 8.2. The lowest engine speed where this power value occurs on the power curve is defined as  $n_{lo}$ .

The engine speeds A, B and C must be calculated as follows:

$$\begin{aligned}\text{Speed A} &= n_{10} + 25 \% (n_{hi} - n_{10}) \\ \text{Speed B} &= n_{10} + 50 \% (n_{hi} - n_{10}) \\ \text{Speed C} &= n_{10} + 75 \% (n_{hi} - n_{10})\end{aligned}$$

The engine speeds A, B and C may be verified by either of the following methods:

- (a) Additional test points must be measured during engine power approval according to Regulation No. 24 for an accurate determination of  $n_{hi}$  and  $n_{10}$ . The maximum power,  $n_{hi}$  and  $n_{10}$  must be determined from the power curve, and engine speeds A, B and C must be calculated according to the above provisions.
- (b) The engine must be mapped along the full load curve, from maximum no load speed to idle speed, using at least 5 measurement points per 1000 rpm intervals and measurement points within  $\pm 50$  rpm of the speed at declared maximum power. The maximum power,  $n_{hi}$  and  $n_{10}$  must be determined from this mapping curve, and engine speeds A, B and C must be calculated according to the above provisions.

If the measured engine speeds A, B and C are within  $\pm 3$  per cent of the engine speeds as declared by the manufacturer, the declared engine speeds must be used for the emissions test. If the tolerance is exceeded for any of the engine speeds, the measured engine speeds must be used for the emissions test.

#### 1.2. Determination of dynamometer settings

The torque curve at full load must be determined by experimentation to calculate the torque values for the specified test modes under net conditions, as specified in annex 1, appendix 1, paragraph 8.2. The power absorbed by engine-driven equipment, if applicable, must be taken into account. The dynamometer setting for each test mode must be calculated using the formula:

$$s = P(n) * \frac{L}{100}$$

if tested under net conditions

$$s = P(n) * \frac{L}{100} + (P(a) - P(b))$$

if not tested under net conditions

where:

s = dynamometer setting, kW

P(n) = net engine power as indicated in annex 1, appendix 1, paragraph 8.2., kW

L = per cent load as indicated in paragraph 2.7.1.,

P(a) = power absorbed by auxiliaries to be fitted as indicated in annex 1, appendix 1, paragraph 6.1.

P(b) = power absorbed by auxiliaries to be removed as indicated in annex 1, appendix 1, paragraph 6.2.

## 2. ESC TEST RUN

At the manufacturers request, a dummy test may be run for conditioning of the engine and exhaust system before the measurement cycle.

### 2.1. Preparation of the sampling filters

At least one hour before the test, each filter (pair) must be placed in a closed, but unsealed petri dish and placed in a weighing chamber for stabilisation. At the end of the stabilisation period, each filter (pair) must be weighed and the tare weight must be recorded. The filter (pair) must then be stored in a closed petri dish or sealed filter holder until needed for testing. If the filter (pair) is not used within eight hours of its removal from the weighing chamber, it must be conditioned and reweighed before use.

### 2.2. Installation of the measuring equipment

The instrumentation and sample probes must be installed as required. When using a full flow dilution system for exhaust gas dilution, the tailpipe must be connected to the system.

### 2.3. Starting the dilution system and the engine

The dilution system and the engine must be started and warmed up until all temperatures and pressures have stabilised at maximum power according to the recommendation of the manufacturer and good engineering practice.

### 2.4. Starting the particulate sampling system

The particulate sampling system must be started and running on by-pass. The particulate background level of the dilution air may be determined by passing dilution air through the particulate filters. If filtered dilution air is used, one measurement may be done prior to or after the test. If the dilution air is not filtered, measurements at the beginning and at the end of the cycle, may be done, and the values averaged.

### 2.5. Adjustment of the dilution ratio

The dilution air must be set such that the temperature of the diluted exhaust gas measured immediately prior to the primary filter must not exceed 325 K (52°C) at any mode. The dilution ratio ( $q$ ) must not be less than 4.

For systems that use CO<sub>2</sub> or NO<sub>x</sub> concentration measurement for dilution ratio control, the CO<sub>2</sub> or NO<sub>x</sub> content of the dilution air must be measured at the beginning and at the end of each test. The pre- and

post test background CO<sub>2</sub> or NO<sub>x</sub> concentration measurements of the dilution air must be within 100 ppm or 5 ppm of each other, respectively.

2.6. Checking the analysers

The emission analysers must be set at zero and spanned.

2.7. Test cycle

2.7.1. The following 13-mode cycle must be followed in dynamometer operation on the test engine:

Mode Number	Engine Speed	Percent Load	Weighting Factor	Mode Length
1	idle	-	0.15	4 minutes
2	A	100	0.08	2 minutes
3	B	50	0.10	2 minutes
4	B	75	0.10	2 minutes
5	A	50	0.05	2 minutes
6	A	75	0.05	2 minutes
7	A	25	0.05	2 minutes
8	B	100	0.09	2 minutes
9	B	25	0.10	2 minutes
10	C	100	0.08	2 minutes
11	C	25	0.05	2 minutes
12	C	75	0.05	2 minutes
13	C	50	0.05	2 minutes

2.7.2. Test sequence

The test sequence must be started. The test must be performed in the order of the mode numbers as set out in paragraph 2.7.1.

The engine must be operated for the prescribed time in each mode, completing engine speed and load changes in the first 20 seconds. The specified speed must be held to within  $\pm 50$  rpm and the specified torque must be held to within  $\pm 2$  per cent of the maximum torque at the test speed.

At the manufacturers request, the test sequence may be repeated a sufficient number of times for sampling more particulate mass on the filter. The manufacturer must supply a detailed description of the data evaluation and calculation procedures. The gaseous emissions must only be determined on the first cycle.

2.7.3. Analyser response

The output of the analysers must be recorded on a strip chart recorder or measured with an equivalent data acquisition system with the exhaust gas flowing through the analysers throughout the test cycle.



#### 2.7.4. Particulate sampling

One pair of filters (primary and back-up filters, see annex 4, appendix 4) must be used for the complete test procedure. The modal weighting factors specified in the test cycle procedure must be taken into account by taking a sample proportional to the exhaust mass flow during each individual mode of the cycle. This can be achieved by adjusting sample flow rate, sampling time, and/or dilution ratio, accordingly, so that the criterion for the effective weighting factors in paragraph 5.6. is met.

The sampling time per mode must be at least 4 seconds per 0.01 weighting factor. Sampling must be conducted as late as possible within each mode. Particulate sampling must be completed no earlier than 5 seconds before the end of each mode.

#### 2.7.5. Engine conditions

The engine speed and load, intake air temperature and depression, exhaust temperature and back pressure, fuel flow and air or exhaust flow, charge air temperature, fuel temperature and humidity must be recorded during each mode, with the speed and load requirements (see paragraph 2.7.2) being met during the time of particulate sampling, but in any case during the last minute of each mode.

Any additional data required for calculation must be recorded (see paragraphs 4 and 5).

#### 2.7.6. NO<sub>x</sub> check within the control area

The NO<sub>x</sub> check within the control area must be performed immediately upon completion of mode 13. The engine must be conditioned at mode 13 for a period of three minutes before the start of the measurements. Three measurements must be made at different locations within the control area, selected by the Technical Service <sup>1</sup>. The time for each measurement must be 2 minutes.

The measurement procedure is identical to the NO<sub>x</sub> measurement on the 13-mode cycle, and must be carried out in accordance with paragraphs 2.7.3., 2.7.5., and 4.1. of this appendix, and annex 4, appendix 4, paragraph 3.

The calculation must be carried out in accordance with paragraph 4.

#### 2.7.7. Rechecking the analysers

After the emission test a zero gas and the same span gas must be used for rechecking. The test will be considered acceptable if the difference between the pre-test and post-test results is less than 2 per cent of the span gas value.

---

<sup>1</sup> The test points must be selected using approved statistical methods of randomisation.

3. ELR TEST RUN

3.1. Installation of the measuring equipment

The opacimeter and sample probes, if applicable, must be installed after the exhaust silencer or any after-treatment device, if fitted, according to the general installation procedures specified by the instrument manufacturer. Additionally, the requirements of paragraph 10 of ISO IDS 11614 must be observed, where appropriate.

Prior to any zero and full scale checks, the opacimeter must be warmed up and stabilised according to the instrument manufacturer's recommendations. If the opacimeter is equipped with a purge air system to prevent sooting of the meter optics, this system must also be activated and adjusted according to the manufacturer's recommendations.

3.2. Checking of the opacimeter

The zero and full scale checks must be made in the opacity readout mode, since the opacity scale offers two truly definable calibration points, namely 0 per cent opacity and 100 per cent opacity. The light absorption coefficient is then correctly calculated based upon the measured opacity and the  $L_A$ , as submitted by the opacimeter manufacturer, when the instrument is returned to the k readout mode for testing.

With no blockage of the opacimeter light beam, the readout must be adjusted to  $0.0 \% \pm 1.0 \%$  opacity. With the light being prevented from reaching the receiver, the readout must be adjusted to  $100.0 \% \pm 1.0 \%$  opacity.

3.3. Test cycle

3.3.1. Conditioning of the engine

Warming up of the engine and the system must be at maximum power in order to stabilise the engine parameters according to the recommendation of the manufacturer. The preconditioning phase should also protect the actual measurement against the influence of deposits in the exhaust system from a former test.

When the engine is stabilised, the cycle must be started within  $20 \pm 2$  s after the preconditioning phase. At the manufacturers request, a dummy test may be run for additional conditioning before the measurement cycle.

3.3.2. Test sequence

The test consists of a sequence of three load steps at each of the three engine speeds A (cycle 1), B (cycle 2) and C (cycle 3) determined in accordance with annex 4, paragraph 1.1., followed by cycle 4 at a speed within the control area and a load between 10 per cent and 100 per cent, selected by the Technical Service <sup>1</sup>. The following

---

<sup>1</sup> The test points must be selected using approved statistical methods of randomisation.

sequence must be followed in dynamometer operation on the test engine, as shown in Figure 3.

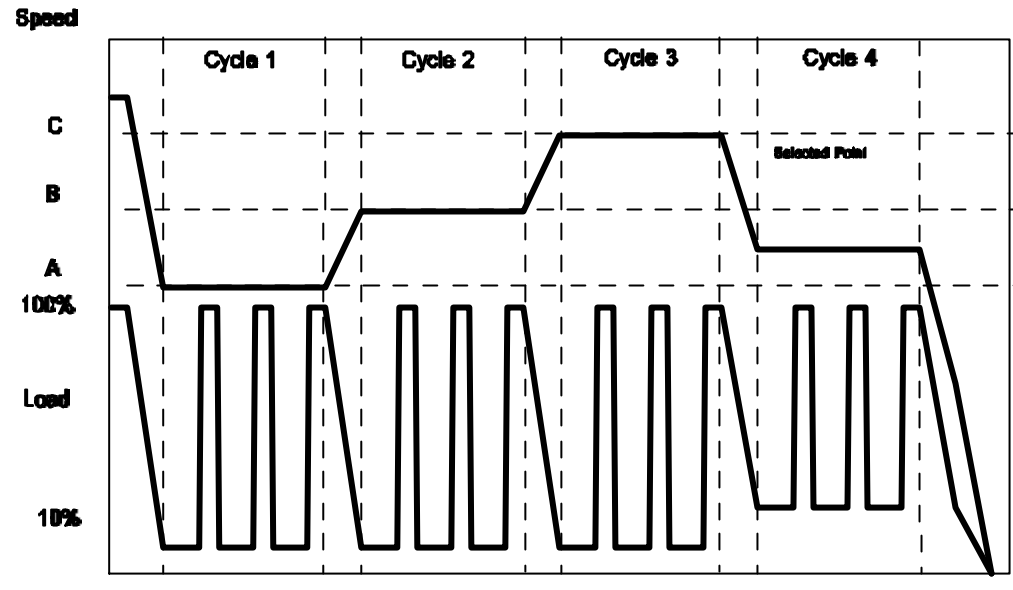

Figure 3: Sequence of ELR Test

- (a) The engine must be operated at engine speed A and 10 per cent load for  $20 \pm 2$  s. The specified speed must be held to within  $\pm 20$  rpm and the specified torque must be held to within  $\pm 2$  per cent of the maximum torque at the test speed.
- (b) At the end of the previous segment, the speed control lever must be moved rapidly to, and held in, the wide open position for  $10 \pm 1$  s. The necessary dynamometer load must be applied to keep the engine speed within  $\pm 150$  rpm during the first 3 s, and within  $\pm 20$  rpm during the rest of the segment.
- (c) The sequence described in (a) and (b) must be repeated two times.
- (d) Upon completion of the third load step, the engine must be adjusted to engine speed B and 10 per cent load within  $20 \pm 2$  s.
- (e) The sequence (a) to (c) must be run with the engine operating at engine speed B.
- (f) Upon completion of the third load step, the engine must be adjusted to engine speed C and 10 per cent load within  $20 \pm 2$  s.
- (g) The sequence (a) to (c) must be run with the engine operating at engine speed C.
- (h) Upon completion of the third load step, the engine must be adjusted to the selected engine speed and any load above 10 per cent within  $20 \pm 2$  s.
- (i) The sequence (a) to (c) must be run with the engine operating at the selected engine speed.

3.4. Cycle validation

The relative standard deviations of the mean smoke values at each test speed ( $SV_A$ ,  $SV_B$ ,  $SV_C$ , as calculated in accordance with paragraph 6.3.3. of this appendix from the three successive load steps at each test speed) must be lower than 15 per cent of the mean value, or 10 per cent of the limit value shown in Table 1 of the Regulation, whichever is greater. If the difference is greater, the sequence must be repeated until 3 successive load steps meet the validation criteria.

3.5. Rechecking of the opacimeter

The post-test opacimeter zero drift value must not exceed  $\pm 5.0$  per cent of the limit value shown in Table 1 of the Regulation.

4. CALCULATION OF THE GASEOUS EMISSIONS

4.1. Data evaluation

For the evaluation of the gaseous emissions, the chart reading of the last 30 seconds of each mode must be averaged, and the average concentrations (conc) of HC, CO and  $NO_x$  during each mode must be determined from the average chart readings and the corresponding calibration data. A different type of recording can be used if it ensures an equivalent data acquisition.

For the  $NO_x$  check within the control area, the above requirements apply for  $NO_x$ , only.

The exhaust gas flow  $G_{EXHW}$  or the diluted exhaust gas flow  $G_{TOTW}$ , if used optionally, must be determined in accordance with annex 4, appendix 4, paragraph 2.3.

4.2. Dry / Wet correction

The measured concentration must be converted to a wet basis according to the following formulae, if not already measured on a wet basis.

$$\text{conc(wet)} = K_w * \text{conc(dry)}$$

For the raw exhaust gas:

$$K_{w,r} = \left( 1 - F_{FH} * \frac{G_{FUEL}}{G_{AIRD}} \right) - K_{w2}$$

and

$$F_{FH} = \frac{1,969}{\left( 1 + \frac{G_{FUEL}}{G_{AIRW}} \right)}$$

For the diluted exhaust gas:

$$K_{W,e,1} = \left( 1 - \frac{HTCRAT * CO_2 \% (wet)}{200} \right) - K_{W1}$$

or

$$K_{W,e,2} = \left( \frac{(1 - K_{W1})}{1 + \frac{HTCRAT * CO_2 \% (dry)}{200}} \right)$$

For the dilution air:

$$K_{W,d} = 1 - K_{W1}$$

$$K_{W1} = \frac{1,608 * H_d}{1000 + (1,608 * H_d)}$$

$$H_d = \frac{6,220 * R_d * p_d}{p_B - p_d * R_d * 10^{-2}}$$

For the intake air:  
(if different from  
the dilution air)

$$K_{W,a} = 1 - K_{W2}$$

$$K_{W2} = \frac{1,608 * H_a}{1000 + (1,608 * H_a)}$$

$$H_a = \frac{6,220 * R_a * p_a}{p_B - p_a * R_a * 10^{-2}}$$

where:

$H_a, H_d$  = g water per kg dry air

$R_d, R_a$  = relative humidity of the dilution/intake air, %

$p_d, p_a$  = saturation vapour pressure of the dilution/intake air, kPa

$p_B$  = total barometric pressure, kPa

#### 4.3. NO<sub>x</sub> Correction for humidity and temperature

As the NO<sub>x</sub> emission depends on ambient air conditions, the NO<sub>x</sub> concentration must be corrected for ambient air temperature and humidity with the factors given in the following formulae:

$$K_{H,D} = \frac{1}{1 + A * (H_a - 10,71) + B * (T_a - 298)}$$

with:

$$A = 0.309 \frac{G_{FUEL}}{G_{AIRD}} - 0.0266$$

$$B = -0.209 \frac{G_{FUEL}}{G_{AIRD}} + 0.00954$$

$T_a$  = temperature of the air, K  
 $H_a$  = humidity of the intake air, g water per kg dry air in which:

$$H_a = \frac{6,220 * R_a * p_a}{p_B - p_a * R_a * 10^{-2}}$$

$R_a$  = relative humidity of the intake air, %  
 $\tilde{p}_a$  = saturation vapour pressure of the intake air, kPa  
 $\tilde{p}_B$  = total barometric pressure, kPa

#### 4.4. Calculation of the emission mass flow rates

The emission mass flow rates (g/h) for each mode must be calculated as follows, assuming the exhaust gas density to be 1.293 kg/m<sup>3</sup> at 273 K (0°C) and 101.3 kPa:

$$(1) \text{ NO}_{x \text{ mass}} = 0.001587 * \text{NO}_{x \text{ conc}} * K_{H,D} * G_{EXHW}$$

$$(2) \text{ CO}_{\text{mass}} = 0.000966 * \text{CO}_{\text{conc}} * G_{EXHW}$$

$$(3) \text{ HC}_{\text{mass}} = 0.000479 * \text{HC}_{\text{conc}} * G_{EXHW}$$

where  $\text{NO}_{x \text{ conc}}$ ,  $\text{CO}_{\text{conc}}$ ,  $\text{HC}_{\text{conc}}$ <sup>1</sup> are the average concentrations (ppm) in the raw exhaust gas, as determined in paragraph 4.1.

If, optionally, the gaseous emissions are determined with a full flow dilution system, the following formulae must be applied:

$$(1) \text{ NO}_{x \text{ mass}} = 0.001587 * \text{NO}_{x \text{ conc}} * K_{H,D} * G_{TOTW}$$

$$(2) \text{ CO}_{\text{mass}} = 0.000966 * \text{CO}_{\text{conc}} * G_{TOTW}$$

$$(3) \text{ HC}_{\text{mass}} = 0.000479 * \text{HC}_{\text{conc}} * G_{TOTW}$$

where  $\text{NO}_{x \text{ conc}}$ ,  $\text{CO}_{\text{conc}}$ ,  $\text{HC}_{\text{conc}}$ <sup>1</sup> are the average background corrected concentrations (ppm) of each mode in the diluted exhaust gas, as determined in annex 4, appendix 2, paragraph 4.3.1.1.

#### 4.5. Calculation of the specific emissions

The emissions (g/kWh) must be calculated for all individual components in the following way:

$$\overline{\text{NO}_x} = \frac{\sum \text{NO}_{x, \text{mass}} * \text{WF}_i}{\sum P(n)_i * \text{WF}_i}$$

$$\overline{\text{CO}} = \frac{\sum \text{CO}_{\text{mass}} * \text{WF}_i}{\sum P(n)_i * \text{WF}_i}$$

---

<sup>1</sup> Based on C1 equivalent

$$\overline{HC} = \frac{\sum HC_{mass} * WF_i}{\sum P(n)_i * WF_i}$$

The weighting factors (WF) used in the above calculation are according to paragraph 2.7.1.

#### 4.6. Calculation of the area control values

For the three control points selected according to paragraph 2.7.6., the NO<sub>x</sub> emission must be measured and calculated according to paragraph 4.6.1. and also determined by interpolation from the modes of the test cycle closest to the respective control point according to paragraph 4.6.2. The measured values are then compared to the interpolated values according to paragraph 4.6.3.

##### 4.6.1. Calculation of the specific emission

The NO<sub>x</sub> emission for each of the control points (Z) must be calculated as follows:

$$NO_{x \text{ mass},Z} = 0.001587 * NO_{x \text{ conc},Z} * K_{H,D} * G_{EXHW}$$

$$NO_{x,Z} = NO_{x \text{ mass},Z} / P(n)_Z$$

##### 4.6.2. Determination of the emission value from the test cycle

The NO<sub>x</sub> emission for each of the control points must be interpolated from the four closest modes of the test cycle that envelop the selected control point Z as shown in Figure 4. For these modes (R, S, T, U), the following definitions apply:

$$\text{Speed}(R) = \text{Speed}(T) = n_{RT}$$

$$\text{Speed}(S) = \text{Speed}(U) = n_{SU}$$

$$\text{Per cent load}(R) = \text{Per cent load}(S)$$

$$\text{Per cent load}(T) = \text{Per cent load}(U).$$

The NO<sub>x</sub> emission of the selected control point Z must be calculated as follows:

$$E_Z = E_{RS} + (E_{TU} - E_{RS}) \cdot (M_Z - M_{RS}) / (M_{TU} - M_{RS})$$

and:

$$E_{TU} = E_T + (E_U - E_T) \cdot (n_Z - n_{RT}) / (n_{SU} - n_{RT})$$

$$E_{RS} = E_R + (E_S - E_R) \cdot (n_Z - n_{RT}) / (n_{SU} - n_{RT})$$

$$M_{TU} = M_T + (M_U - M_T) \cdot (n_Z - n_{RT}) / (n_{SU} - n_{RT})$$

$$M_{RS} = M_R + (M_S - M_R) \cdot (n_Z - n_{RT}) / (n_{SU} - n_{RT})$$

where:

$E_R, E_S, E_T, E_U$  = specific NO<sub>x</sub> emission of the enveloping modes calculated in accordance with paragraph 4.6.1.

$M_R, M_S, M_T, M_U$  = engine torque of the enveloping modes

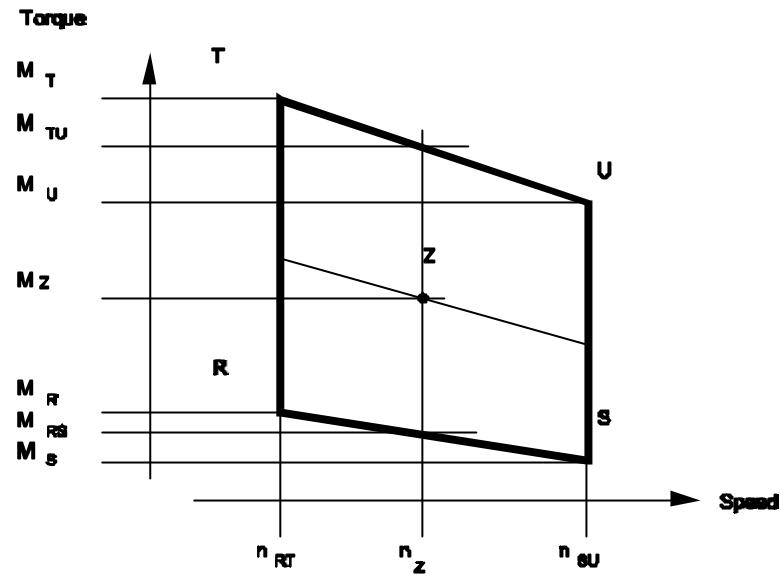

Figure 4: Interpolation of NO<sub>x</sub> Control Point

#### 4.6.3. Comparison of NO<sub>x</sub> emission values

The measured specific NO<sub>x</sub> emission of the control point Z (NO<sub>x,z</sub>) is compared to the interpolated value (E<sub>z</sub>) as follows:

$$NO_{x,diff} = 100 * (NO_{x,z} - E_z) / E_z$$

### 5. CALCULATION OF THE PARTICULATE EMISSION

#### 5.1. Data evaluation

For the evaluation of the particulates, the total sample masses (M<sub>SAM,i</sub>) through the filters must be recorded for each mode.

The filters must be returned to the weighing chamber and conditioned for at least one hour, but not more than 80 hours, and then weighed. The gross weight of the filters must be recorded and the tare weight (see paragraph 1 of this appendix) subtracted. The particulate mass M<sub>f</sub> is the sum of the particulate masses collected on the primary and back-up filters.

If background correction is to be applied, the dilution air mass (M<sub>DIL</sub>) through the filters and the particulate mass (M<sub>d</sub>) must be recorded. If more than one measurement was made, the quotient M<sub>d</sub>/M<sub>DIL</sub> must be calculated for each single measurement and the values averaged.

#### 5.2. Partial flow dilution system

The final reported test results of the particulate emission must be determined through the following steps. Since various types of dilution rate control may be used, different calculation methods for



$G_{EDFW}$  apply. All calculations must be based upon the average values of the individual modes during the sampling period.

### 5.2.1. Isokinetic systems

$$G_{EDFW,i} = G_{EXHW,i} * q_i$$

$$q_i = \frac{G_{DILW,i} + (G_{EXHW,i} * r)}{(G_{EXHW,i} * r)}$$

where  $r$  corresponds to the ratio of the cross sectional areas of the isokinetic probe and the exhaust pipe:

$$r = \frac{A_p}{A_r}$$

### 5.2.2. Systems with measurement of CO<sub>2</sub> or NO<sub>x</sub> concentration

$$G_{EDFW,i} = G_{EXHW,i} * q_i$$

$$q_i = \frac{conc_{E,i} - conc_{A,i}}{conc_{D,i} - conc_{A,i}}$$

where:

conc<sub>E</sub> = wet concentration of the tracer gas in the raw exhaust  
 conc<sub>D</sub> = wet concentration of the tracer gas in the diluted exhaust  
 conc<sub>A</sub> = wet concentration of the tracer gas in the dilution air

Concentrations measured on a dry basis must be converted to a wet basis according to paragraph 4.2. of this appendix.

### 5.2.3. Systems with CO<sub>2</sub> measurement and carbon balance method <sup>1</sup>

$$G_{EDFW,i} = \frac{206.5 - G_{FUEL,i}}{CO_{2D,i} - CO_{2A,i}}$$

where:

CO<sub>2D</sub> = CO<sub>2</sub> concentration of the diluted exhaust  
 CO<sub>2A</sub> = CO<sub>2</sub> concentration of the dilution air  
 (concentrations in Vol % on wet basis)

This equation is based upon the carbon balance assumption (carbon atoms supplied to the engine are emitted as CO<sub>2</sub>) and determined through the following steps:

$$G_{EDFW,i} = G_{EXHW,i} * q_i$$

---

<sup>1</sup> The value is only valid for the reference fuel specified in the Regulation.

$$q_i = \frac{206,5 * G_{FUEL,i}}{G_{EXW,i} * (CO_{2D,i} - CO_{2A,i})}$$

and,

5.2.4. Systems with flow measurement

$$G_{EDFW,i} = G_{EXHW,i} * q_i$$

$$q_i = \frac{G_{TOTW,i}}{(G_{TOTW,i} - G_{DILW,i})}$$

5.3. Full flow dilution system

The reported test results of the particulate emission must be determined through the following steps. All calculations must be based upon the average values of the individual modes during the sampling period.

$$G_{EDFW,i} = G_{TOTW,i}$$

5.4. Calculation of the particulate mass flow rate

The particulate mass flow rate must be calculated as follows:

$$PT_{mass} = \frac{M_f}{M_{SAM}} * \frac{\overline{G_{EDFW}}}{1000}$$

where

$$\overline{G_{EDFW}} = \sum_{i=1}^{i=n} G_{EDFW,i} * WF_i$$

$$M_{SAM} = \sum_{i=1}^{i=n} M_{SAM,i}$$

$i=1, \dots, n$

determined over the test cycle by summation of the average values of the individual modes during the sampling period.

The particulate mass flow rate may be background corrected as follows:

$$PT_{mass} = \left[ \frac{M_f}{M_{SAM}} - \left( \frac{M_d}{M_{DIL}} * \left( \sum_{i=n}^{i=n} \left( 1 - \frac{1}{DF_i} \right) * WF_i \right) \right) \right] * \frac{\overline{G_{EDFW}}}{1000}$$

If more than one measurement is made,  $(M_d/M_{DIL})$  must be replaced with the average value of  $(M_d/M_{DIL})$ .

$$DF_i = 13.4 / (\text{conc CO}_2 + (\text{conc CO} + \text{conc HC}) * 10^{-4}) \quad \text{for the individual modes}$$

or,

$$DF_i = 13.4 / \text{concCO}_2 \quad \text{for the individual modes}$$

#### 5.5. Calculation of the specific emission

The particulate emission must be calculated in the following way:

$$\overline{PT} = \frac{PT_{mass}}{\sum P(n)_i * WF_i}$$

#### 5.6. Effective weighting factor

The effective weighting factor  $WF_{E,i}$  for each mode must be calculated in the following way:

$$WF_{E,i} = \frac{M_{SAM,i} * \overline{G_{EDFW}}}{M_{SAM} * G_{EDFW,i}}$$

The value of the effective weighting factors must be within  $\pm 0.003$  (0.005 for the idle mode) of the weighting factors listed in paragraph 2.7.1.

### 6. CALCULATION OF THE SMOKE VALUES

#### 6.1. Bessel algorithm

The Bessel algorithm must be used to compute the 1 s average values from the instantaneous smoke readings, converted in accordance with paragraph 6.3.1. The algorithm emulates a low pass second order filter, and its use requires iterative calculations to determine the coefficients. These coefficients are a function of the response time of the opacimeter system and the sampling rate. Therefore, paragraph 6.1.1. must be repeated whenever the system response time and/or sampling rate changes.

### 6.1.1. Calculation of filter response time and Bessel constants

The required Bessel response time ( $t_F$ ) is a function of the physical and electrical response times of the opacimeter system, as specified in annex 4, appendix 4, paragraph 5.2.4., and must be calculated by the following equation:

$$t_f = \sqrt{1 - (t_p^2 + t_e^2)}$$

where:

$t_p$  = physical response time, s  
 $t_e$  = electrical response time, s

The calculations for estimating the filter cut-off frequency ( $f_c$ ) are based on a step input of 0 to 1 in 0.01s (see annex 8). The response time is defined as the time between when the Bessel output reaches 10 per cent ( $t_{10}$ ) and when it reaches 90 per cent ( $t_{90}$ ) of this step function. This must be obtained by iterating on  $f_c$  until  $t_{90} - t_{10} \approx t_F$ . The first iteration for  $f_c$  is given by the following formula :

$$f_c = \delta / (10 * t_F)$$

The Bessel constants E and K must be calculated by the following equations:

$$E = \frac{1}{1 + \Omega * \sqrt{3 * D} + D * \Omega^2}$$

$$K = 2 * E * (D * \tilde{\Omega}^2 - 1) - 1$$

where:

$D = 0.618034$   
 $\tilde{\Delta}t = 1 / \text{sampling rate}$   
 $\tilde{\Omega} = 1 / [\tan(\delta * \tilde{\Delta}t * f_c)]$

### 6.1.2. Calculation of the Bessel Algorithm

Using the values of E and K, the 1 s Bessel averaged response to a step input  $S_i$  must be calculated as follows:

$$Y_i = Y_{i-1} + E * (S_i + 2 * S_{i-1} + S_{i-2} - 4 * Y_{i-2}) + K * (Y_{i-1} - Y_{i-2})$$

where:

$S_{i-2} = S_{i-1} = 0$   
 $S_i = 1$   
 $Y_{i-2} = Y_{i-1} = 0$

The times  $t_{10}$  and  $t_{90}$  must be interpolated. The difference in time between  $t_{90}$  and  $t_{10}$  defines the response time  $t_F$  for that value of  $f_c$ . If this response time is not close enough to the required response

time, iteration must be continued until the actual response time is within 1 per cent of the required response as follows:

$$|(t_{90} - t_{10}) - t_F| \leq 0,01 * t_F$$

## 6.2 Data evaluation

The smoke measurement values must be sampled with a minimum rate of 20 Hz.

## 6.3 Determination of smoke

### 6.3.1 Data conversion

Since the basic measurement unit of all opacimeters is transmittance, the smoke values must be converted from transmittance ( $\hat{o}$ ) to the light absorption coefficient ( $k$ ) as follows:

$$k = -\frac{1}{L_A} * \ln\left(1 - \frac{N}{100}\right)$$

and:  $N = 100 - \hat{o}$

where:

$k$  = light absorption coefficient,  $m^{-1}$

$L_A$  = effective optical path length, as submitted by instrument manufacturer, m

$N$  = opacity, %

$\hat{o}$  = transmittance, %

The conversion must be applied, before any further data processing is made.

### 6.3.2 Calculation of Bessel averaged smoke

The proper cut-off frequency  $f_c$  is the one that produces the required filter response time  $t_F$ . Once this frequency has been determined through the iterative process of paragraph 6.1.1., the proper Bessel algorithm constants  $E$  and  $K$  must be calculated. The Bessel algorithm must then be applied to the instantaneous smoke trace ( $k$ -value), as described in paragraph 6.1.2:

$$Y_i = Y_{i-1} + E * (S_i + 2 * S_{i-1} + S_{i-2} - 4 * Y_{i-2}) + K * (Y_{i-1} - Y_{i-2})$$

The Bessel algorithm is recursive in nature. Thus, it needs some initial input values of  $S_{i-1}$  and  $S_{i-2}$  and initial output values  $Y_{i-1}$  and  $Y_{i-2}$  to get the algorithm started. These may be assumed to be 0.

For each load step of the three speeds A, B and C, the maximum  $1s$  value  $Y_{max}$  must be selected from the individual  $Y_i$  values of each smoke trace.

### 6.3.3 Final result

The mean smoke values (SV) from each cycle (test speed) must be calculated as follows:

$$\text{For test speed A:} \quad SV_A = (Y_{\max 1,A} + Y_{\max 2,A} + Y_{\max 3,A}) / 3$$

$$\text{For test speed B:} \quad SV_B = (Y_{\max 1,B} + Y_{\max 2,B} + Y_{\max 3,B}) / 3$$

$$\text{For test speed C:} \quad SV_C = (Y_{\max 1,C} + Y_{\max 2,C} + Y_{\max 3,C}) / 3$$

where:

$Y_{\max 1}, Y_{\max 2}, Y_{\max 3}$  = highest 1 s Bessel averaged smoke value at each of the three load steps

The final value must be calculated as follows:

$$SV = (0.43 * SV_A) + (0.56 * SV_B) + (0.01 * SV_C)$$

\_\_\_\_\_ "

Annex 4 - Appendix 2, amend to read

#### "Annex 4 - Appendix 2

##### ETC TEST CYCLE

### 1. ENGINE MAPPING PROCEDURE

#### 1.1. Determination of the mapping speed range

For generating the ETC on the test cell, the engine needs to be mapped prior to the test cycle for determining the speed vs. torque curve. The minimum and maximum mapping speeds are defined as follows:

Minimum mapping speed = idle speed

Maximum mapping speed =  $n_{hi} * 1.02$  or speed where full load torque drops off to zero, whichever is lower

#### 1.2. Performing the engine power map

The engine must be warmed up at maximum power in order to stabilise the engine parameters according to the recommendation of the manufacturer and good engineering practice. When the engine is stabilised, the engine map must be performed as follows:

The engine must be unloaded and operated at idle speed.

The engine must be operated at full load setting of the injection pump at minimum mapping speed.

The engine speed must be increased at an average rate of  $8 \pm 1 \text{ min}^{-1}$  /s from minimum to maximum mapping speed. Engine speed and torque points must be recorded at a sample rate of a least one point per second.

1.3. Mapping curve generation

All data points recorded under paragraph 1.2. must be connected using linear interpolation between points. The resulting torque curve is the mapping curve and must be used to convert the normalised torque values of the engine cycle into actual torque values for the test cycle, as described in paragraph 2.

1.4. Alternate mapping

If a manufacturer believes that the above mapping techniques are unsafe or unrepresentative for any given engine, alternate mapping techniques may be used. These alternate techniques must satisfy the intent of the specified mapping procedures to determine the maximum available torque at all engine speeds achieved during the test cycles. Deviations from the mapping techniques specified in this paragraph for reasons of safety or representativeness must be approved by the Technical Service along with the justification for their use. In no case, however, must descending continual sweeps of engine speed be used for governed or turbocharged engines.

1.5. Replicate tests

An engine need not be mapped before each and every test cycle. An engine must be remapped prior to a test cycle if:

- an unreasonable amount of time has transpired since the last map, as determined by engineering judgement,

or,

- physical changes or recalibrations have been made to the engine, which may potentially affect engine performance.

2. GENERATION OF THE REFERENCE TEST CYCLE

The transient test cycle is described in appendix 3 to this annex. The normalised values for torque and speed must be changed to the actual values, as follows, resulting in the reference cycle.

2.1. Actual speed

The speed must be unnormalised using the following equation:

$$\text{Actual speed} = \frac{\% \text{ speed (reference speed - idle speed)}}{100} + \text{idle speed}$$

The reference speed ( $n_{ref}$ ) corresponds to the 100 per cent speed values specified in the engine dynamometer schedule of appendix 3. It is defined as follows (see Figure 1 of the Regulation):

$$n_{ref} = n_{lo} + 95 \% * (n_{hi} - n_{lo})$$

where  $n_{hi}$  and  $n_{lo}$  are either specified according to the Regulation, paragraph 2 or determined according to annex 4, appendix 1, paragraph 1.1.

## 2.2. Actual torque

The torque is normalised to the maximum torque at the respective speed. The torque values of the reference cycle must be unnormalised, using the mapping curve determined according to section 1.3, as follows:

$$\text{Actual torque} = \frac{\% \text{ torque} * \text{max . torque}}{100}$$

for the respective actual speed as determined in paragraph 2.1.

The negative torque values of the motoring points ("m") must take on, for purposes of reference cycle generation, unnormalised values determined in either of the following ways:

- negative 40 per cent of the positive torque available at the associated speed point;
- mapping of the negative torque required to motor the engine from minimum to maximum mapping speed;
- determination of the negative torque required to motor the engine at idle and reference speeds and linear interpolation between these two points.

## 2.3. Example of the unnormalisation procedure

As an example, the following test point must be unnormalised:

% speed = 43  
% torque = 82

Given the following values:

reference speed = 2200 min<sup>-1</sup>  
idle speed = 600 min<sup>-1</sup>

results in,

$$\text{actual speed} = \frac{43 * (2200 - 600)}{100} + 600 = 1288 \text{ min}^{-1}$$



$$\text{actual torque} = \frac{82 * 700}{100} = 574Nm$$

where the maximum torque observed from the mapping curve at 1288 min<sup>-1</sup> is 700 Nm.

### 3. EMISSIONS TEST RUN

At the manufacturers request, a dummy test may be run for conditioning of the engine and exhaust system before the measurement cycle.

NG and LPG fuelled engines must be run-in using the ETC test. The engine must be run over a minimum of two ETC cycles and until the CO emission measured over one ETC cycle does not exceed by more than 10 per cent the CO emission measured over the previous ETC cycle.

#### 3.1. Preparation of the sampling filters (Diesel engines only)

At least one hour before the test, each filter (pair) must be placed in a closed, but unsealed petri dish and placed in a weighing chamber for stabilisation. At the end of the stabilisation period, each filter (pair) must be weighed and the tare weight must be recorded. The filter (pair) must then be stored in a closed petri dish or sealed filter holder until needed for testing. If the filter (pair) is not used within eight hours of its removal from the weighing chamber, it must be conditioned and reweighed before use.

#### 3.2. Installation of the measuring equipment

The instrumentation and sample probes must be installed as required. The tailpipe must be connected to the full flow dilution system.

#### 3.3. Starting the dilution system and the engine

The dilution system and the engine must be started and warmed up until all temperatures and pressures have stabilised at maximum power according to the recommendation of the manufacturer and good engineering practice.

#### 3.4. Starting the particulate sampling system (Diesel engines only)

The particulate sampling system must be started and running on by-pass. The particulate background level of the dilution air may be determined by passing dilution air through the particulate filters. If filtered dilution air is used, one measurement may be done prior to or after the test. If the dilution air is not filtered, measurements at the beginning and at the end of the cycle, may be done, and the values averaged.

#### 3.5. Adjustment of the full flow dilution system

The total diluted exhaust gas flow must be set to eliminate water condensation in the system, and to obtain a maximum filter face

temperature of 325 K (52°C) or less (see annex 4, appendix 7, paragraph 2.3.1., DT).

3.6. Checking the analysers

The emission analysers must be set at zero and spanned. If sample bags are used, they must be evacuated.

3.7. Engine starting procedure

The stabilised engine must be started according to the manufacturer's recommended starting procedure in the owner's manual, using either a production starter motor or the dynamometer. Optionally, the test may start directly from the engine preconditioning phase without shutting the engine off, when the engine has reached the idle speed.

3.8. Test cycle

3.8.1. Test sequence

The test sequence must be started, if the engine has reached idle speed. The test must be performed according to the reference cycle as set out in paragraph 2 of this appendix. Engine speed and torque command set points must be issued at 5 Hz (10 Hz recommended) or greater. Feedback engine speed and torque must be recorded at least once every second during the test cycle, and the signals may be electronically filtered.

3.8.2. Analyser response

At the start of the engine or test sequence, if the cycle is started directly from the preconditioning,, the measuring equipment must be started, simultaneously:

- start collecting or analysing dilution air;
- start collecting or analysing diluted exhaust gas;
- start measuring the amount of diluted exhaust gas (CVS) and the required temperatures and pressures;
- start recording the feedback data of speed and torque of the dynamometer.

HC and NO<sub>x</sub> must be measured continuously in the dilution tunnel with a frequency of 2 Hz. The average concentrations must be determined by integrating the analyser signals over the test cycle. The system response time must be no greater than 20 s, and must be coordinated with CVS flow fluctuations and sampling time/test cycle offsets, if necessary. CO, CO<sub>2</sub>, NMHC and CH<sub>4</sub> must be determined by integration or by analysing the concentrations in the sample bag, collected over the cycle. The concentrations of the gaseous pollutants in the dilution air must be determined by integration or by collecting into the background bag. All other values must be recorded with a minimum of one measurement per second (1 Hz).

3.8.3. Particulate sampling (Diesel engines only)

At the start of the engine or test sequence, if the cycle is started directly from the preconditioning, the particulate sampling system must be switched from by-pass to collecting particulates.

If no flow compensation is used, the sample pump(s) must be adjusted so that the flow rate through the particulate sample probe or transfer tube is maintained at a value within  $\pm 5$  per cent of the set flow rate. If flow compensation (i.e., proportional control of sample flow) is used, it must be demonstrated that the ratio of main tunnel flow to particulate sample flow does not change by more than  $\pm 5$  per cent of its set value (except for the first 10 seconds of sampling).

Note: For double dilution operation, sample flow is the net difference between the flow rate through the sample filters and the secondary dilution air flow rate.

The average temperature and pressure at the gas meter(s) or flow instrumentation inlet must be recorded. If the set flow rate cannot be maintained over the complete cycle (within  $\pm 5$  per cent) because of high particulate loading on the filter, the test must be voided. The test must be rerun using a lower flow rate and/or a larger diameter filter.

3.8.4. Engine stalling

If the engine stalls anywhere during the test cycle, the engine must be preconditioned and restarted, and the test repeated. If a malfunction occurs in any of the required test equipment during the test cycle, the test must be voided.

3.8.5. Operations after test

At the completion of the test, the measurement of the diluted exhaust gas volume, the gas flow into the collecting bags and the particulate sample pump must be stopped. For an integrating analyser system, sampling must continue until system response times have elapsed.

The concentrations of the collecting bags, if used, must be analysed as soon as possible and in any case not later than 20 minutes after the end of the test cycle.

After the emission test, a zero gas and the same span gas must be used for re-checking the analysers. The test will be considered acceptable if the difference between the pre-test and post-test results is less than 2 per cent of the span gas value.

For diesel engines only, the particulate filters must be returned to the weighing chamber no later than one hour after completion of the test and must be conditioned in a closed, but unsealed petri dish for at least one hour, but not more than 80 hours before weighing.

3.9. Verification of the test run

3.9.1. Data shift

To minimise the biasing effect of the time lag between the feedback and reference cycle values, the entire engine speed and torque feedback signal sequence may be advanced or delayed in time with respect to the reference speed and torque sequence. If the feedback signals are shifted, both speed and torque must be shifted the same amount in the same direction.

3.9.2. Calculation of the cycle work

The actual cycle work  $W_{act}$  (kWh) must be calculated using each pair of engine feedback speed and torque values recorded. This must be done after any feedback data shift has occurred, if this option is selected. The actual cycle work  $W_{act}$  is used for comparison to the reference cycle work  $W_{ref}$  and for calculating the brake specific emissions (see paragraphs 4.4. and 5.2). The same methodology must be used for integrating both reference and actual engine power. If values are to be determined between adjacent reference or adjacent measured values, linear interpolation must be used.

In integrating the reference and actual cycle work, all negative torque values must be set equal to zero and included. If integration is performed at a frequency of less than 5 Hertz, and if, during a given time segment, the torque value changes from positive to negative or negative to positive, the negative portion must be computed and set equal to zero. The positive portion must be included in the integrated value.

$W_{act}$  must be between -15 % and + 5 % of  $W_{ref}$ .

3.9.3. Validation statistics of the test cycle

Linear regressions of the feedback values on the reference values must be performed for speed, torque and power. This must be done after any feedback data shift has occurred, if this option is selected. The method of least squares must be used, with the best fit equation having the form:

$$y = mx + b$$

where:

y = feedback (actual) value of speed ( $\text{min}^{-1}$ ), torque (Nm),  
or power (kW)

m = slope of the regression line

x = reference value of speed ( $\text{min}^{-1}$ ), torque (Nm), or power (kW)

b = y intercept of the regression line

The standard error of estimate (SE) of y on x and the coefficient of determination ( $r^2$ ) must be calculated for each regression line.

It is recommended that this analysis be performed at 1 Hertz. All negative reference torque values and the associated feedback values must be deleted from the calculation of cycle torque and power

validation statistics. For a test to be considered valid, the criteria of table 6 must be met.

Table 6: Regression line tolerances

	Speed	Torque	Power
Standard error of estimate (SE) of Y on X	max 100 min <sup>-1</sup>	max 13 % of power map maximum engine torque	max 8% of power map maximum engine power
Slope of the regression line, m	0.95 to 1.03	0.83 - 1.03	0.89 - 1.03
Coefficient of determination, r <sup>2</sup>	min 0.9700	min 0.8800	min 0.9100
Y intercept of the regression line, b	± 50 min <sup>-1</sup>	± 20 Nm or ± 2 % of max torque whichever is greater	± 4 kW or ± 2 % of max power whichever is greater

Point deletions from the regression analyses are permitted where noted in table 7.

Table 7: Permitted Point Deletions From Regression Analysis

Condition	Points to be deleted
Full load and torque feedback torque reference	Torque and/or power
No load, not an idle point, and torque feedback > torque reference	Torque and/or power
No load/closed throttle, idle point and speed > reference idle speed	Speed and/or power

#### 4. CALCULATION OF THE GASEOUS EMISSIONS

##### 4.1. Determination of the diluted exhaust gas flow

The total diluted exhaust gas flow over the cycle (kg/test) must be calculated from the measurement values over the cycle and the corresponding calibration data of the flow measurement device ( $V_0$  for PDP or  $K_V$  for CFV, as determined in annex 4, appendix 5, paragraph 2.). The following formulae must be applied, if the temperature of the diluted exhaust is kept constant over the cycle by using a heat exchanger ( $\pm 6$  K for a PDP-CVS,  $\pm 11$  K for a CFV-CVS, see annex 4, appendix 7, paragraph 2.3.).

For the PDP-CVS system

$$M_{TOTW} = 1.293 * V_0 * N_P * (p_B - p_1) * 273 / (101.3 * T)$$

where:

$M_{TOTW}$  = mass of the diluted exhaust gas on wet basis over the cycle, kg  
 $V_0$  = volume of gas pumped per revolution under test conditions, m<sup>3</sup>/rev  
 $N_P$  = total revolutions of pump per test  
 $p_B$  = atmospheric pressure in the test cell, kPa  
 $p_1$  = pressure depression below atmospheric at pump inlet, kPa  
 $T$  = average temperature of the diluted exhaust gas at pump inlet over the cycle, K

For the CFV-CVS system

$$M_{TOTW} = 1.293 * t * K_V * p_A / T^{0.5}$$

where:

$M_{TOTW}$  = mass of the diluted exhaust gas on wet basis over the cycle, kg  
 $t$  = cycle time, s  
 $K_V$  = calibration coefficient of the critical flow venturi for standard conditions,  
 $p_A$  = absolute pressure at venturi inlet, kPa  
 $T$  = absolute temperature at venturi inlet, K

If a system with flow compensation is used (i.e. without heat exchanger), the instantaneous mass emissions must be calculated and integrated over the cycle. In this case, the instantaneous mass of the diluted exhaust gas must be calculated as follows.

For the PDP-CVS system:

$$M_{TOTW,I} = 1.293 * V_0 * N_{P,i} * (p_B - p_1) * 273 / (101.3 * T)$$

where:

$M_{TOTW,i}$  = instantaneous mass of the diluted exhaust gas on wet basis, kg  
 $N_{P,i}$  = total revolutions of pump per time interval

For the CFV-CVS system:

$$M_{TOTW,i} = 1.293 * \dot{A}t_i * K_V * p_A / T^{0.5}$$

where:

$M_{TOTW,i}$  = instantaneous mass of the diluted exhaust gas on wet basis, kg  
 $\dot{A}t_i$  = time interval, s

If the total sample mass of particulates (MSAM) and gaseous pollutants exceeds 0.5 per cent of the total CVS flow ( $M_{TOTW}$ ), the CVS flow must be corrected for MSAM or the particulate sample flow must be returned to the CVS prior to the flow measuring device (PDP or CFV).

#### 4.2. NO<sub>x</sub> correction for humidity

As the NO<sub>x</sub> emission depends on ambient air conditions, the NO<sub>x</sub> concentration must be corrected for ambient air humidity with the factors given in the following formulae.

(a) for diesel engines:

$$K_{H,D} = \frac{1}{1 - 0,0182 * (H_a - 10,71)}$$

(b) for gas engines:

$$K_{H,G} = \frac{1}{1 - 0,0329 * (H_a - 10,71)}$$

where:

Ha = humidity of the intake air, grams of water per kg of dry air,

in which:

$$H_a = \frac{6,220 * R_a * p_a}{p_B - p_a * R_a * 10^{-2}}$$

Ra = relative humidity of the intake air, %

pa = saturation vapour pressure of the intake air, kPa

pB = total barometric pressure, kPa

#### 4.3. Calculation of the emission mass flow

##### 4.3.1 Systems with constant mass flow

For systems with heat exchanger, the mass of the pollutants (g/test) must be determined from the following equations:

$$(1) \text{ NO}_x \text{ mass} = 0.001587 * \text{NO}_x \text{ conc} * K_{H,D} * \text{MTOTW (diesel engines)}$$

$$(2) \text{ NO}_x \text{ mass} = 0.001587 * \text{NO}_x \text{ conc} * K_{H,G} * \text{MTOTW (gas engines)}$$

$$(3) \text{ CO mass} = 0.000966 * \text{CO conc} * M_{\text{TOTW}}$$

$$(4) \text{ HC mass} = 0.000479 * \text{HC conc} * M_{\text{TOTW}}' \text{ (diesel engines)}$$

$$(5) \text{ HC mass} = 0.000502 * \text{HC conc} * M_{\text{TOTW}}' \text{ (LPG fuelled engines)}$$

$$(6) \text{ NMHC mass} = 0.000516 * \text{NMHC conc} * M_{\text{TOTW}}' \text{ (NG fuelled engines)}$$

$$(7) \text{ CH}_4 \text{ mass} = 0.000552 * \text{CH}_4 \text{ conc} * M_{\text{TOTW}} \text{ (NG fuelled engines)}$$

where:

NO<sub>x</sub> conc, CO conc, HC conc, <sup>1</sup> NMHC conc = average background corrected concentrations over the cycle from integration (mandatory for NO<sub>x</sub> and HC) or bag measurement, ppm

M<sub>TOTW</sub> = total mass of diluted exhaust gas over the cycle as determined in paragraph 4.1., kg

K<sub>H,D</sub> = humidity correction factor for diesel engines as determined in paragraph 4.2

---

<sup>1</sup> Based on C1 equivalent

$K_{H,G}$  = humidity correction factor for gas engines as determined in paragraph 4.2

Concentrations measured on a dry basis must be converted to a wet basis in accordance with annex 4, appendix 1, paragraph 4.2.

The determination of  $NMHC_{conc}$  depends on the method used (see annex 4, appendix 4, paragraph 3.3.4.). In both cases, the  $CH_4$  concentration must be determined and subtracted from the HC concentration as follows:

(a) GC method

$$NMHC_{conc} = HC_{conc} - CH_4_{conc}$$

(b) NMC method

$$NMHC_{conc} = \frac{HC(w/o\ Cutter) * (1 - CE_M) - HC(w/ Cutter)}{CE_C - CE_M}$$

where:

HC(w/ Cutter) = HC concentration with the sample gas flowing through the NMC

HC(w/o Cutter) = HC concentration with the sample gas bypassing the NMC

$CE_M$  = methane efficiency as determined per annex 4, appendix 5, paragraph 1.8.4.1.

$CE_E$  = ethane efficiency as determined per annex 4, appendix 5, paragraph 1.8.4.2.

#### 4.3.1.1. Determination of the background corrected concentrations

The average background concentration of the gaseous pollutants in the dilution air must be subtracted from measured concentrations to get the net concentrations of the pollutants. The average values of the background concentrations can be determined by the sample bag method or by continuous measurement with integration. The following formula must be used.

$$conc = conc_e - conc_d * (1 - (1/DF))$$

where:

conc = concentration of the respective pollutant in the diluted exhaust gas, corrected by the amount of the respective pollutant contained in the dilution air, ppm

$conc_e$  = concentration of the respective pollutant measured in the diluted exhaust gas, ppm



$conc_d$  = concentration of the respective pollutant measured  
in the dilution air, ppm  
DF = dilution factor

The dilution factor must be calculated as follows:

(a) for diesel and LPG fuelled gas engines

$$DF = \frac{F_s}{CO2_{conce} + (HC_{conce} + CO_{conce}) * 10^{-4}}$$

(b) for NG fuelled gas engines

$$DF = \frac{F_s}{CO2_{conce} + (NMHC_{conca} + CO_{conca}) * 10^{-4}}$$

where:

$CO_{2,conce}$  = concentration of  $CO_2$  in the diluted exhaust gas, % vol  
 $HC_{conce}$  = concentration of HC in the diluted exhaust gas, ppm C1  
 $NMHC_{conce}$  = concentration of NMHC in the diluted exhaust gas, ppm C1  
 $CO_{conce}$  = concentration of CO in the diluted exhaust gas, ppm  
 $F_s$  = stoichiometric factor

Concentrations measured on dry basis must be converted to a wet basis in accordance with annex 4, appendix 1, paragraph 4.2.

The stoichiometric factor must be calculated as follows:

$$F_s = 100 * \frac{x}{x + \frac{y}{2} + 3,76 * \left( x + \frac{y}{4} \right)}$$

where:

$x, y$  = fuel composition  $C_xH_y$

Alternatively, if the fuel composition is not known, the following stoichiometric factors may be used:

$F_s$  (diesel) = 13.4  
 $F_s$  (LPG) = 11.6  
 $F_s$  (NG) = 9.5

#### 4.3.2. Systems with flow compensation

For systems without heat exchanger, the mass of the pollutants (g/test) must be determined by calculating the instantaneous mass emissions and integrating the instantaneous values over the cycle. Also, the background correction must be applied directly to the instantaneous concentration value. The following formulae must be applied:

(1)  $NO_x$  mass =

$$\sum_{i=1}^n (M_{TOTW,i} * NO_{x,conce,i} * 0,001587 * K_{H,D}) - (M_{TOTW} * NO_{x,concd} * (1 - 1/DF) * 0,001587 * K_{H,D})$$

(diesel engines)

(2)  $NO_x$  mass =

$$\sum_{i=1}^n (M_{TOTW,i} * NO_{x,conce,i} * 0,001587 * K_{H,G}) - (M_{TOTW} * NO_{x,concd} * (1 - 1/DF) * 0,001587 * K_{H,G})$$

(gas engines)

(3)  $CO_{mass}$  =

$$\sum_{i=1}^n (M_{TOTW,i} * CO_{conce,i} * 0,000966) - (M_{TOTW} * CO_{concd} * (1 - 1/DF) * 0,000966)$$

(4)  $HC_{mass}$  =

$$\sum_{i=1}^n (M_{TOTW,i} * HC_{conce,i} * 0,000479) - (M_{TOTW} * HC_{concd} * (1 - 1/DF) * 0,000479)$$

(diesel engines)

(5)  $HC_{mass}$  =

$$\sum_{i=1}^n (M_{TOTW,i} * HC_{conce,i} * 0,000502) - (M_{TOTW} * HC_{concd} * (1 - 1/DF) * 0,000502)$$

(LPG engines)

(6)  $NMHC_{mass}$  =

$$\sum_{i=1}^n (M_{TOTW,i} * NMHC_{conce,i} * 0,000516) - (M_{TOTW} * NMHC_{concd} * (1 - 1/DF) * 0,000516)$$

(NG engines)

(7)  $CH_4$  mass =

$$\sum_{i=1}^n (M_{TOTW,i} * CH_{4conce,i} * 0,000552) - (M_{TOTW} * CH_{4concd} * (1 - 1/DF) * 0,000552)$$

(NG engines)

where:

$conc_e$  = concentration of the respective pollutant measured in the diluted exhaust gas, ppm

$conc_d$  = concentration of the respective pollutant measured in the dilution air, ppm

$M_{TOTW,I}$  = instantaneous mass of the diluted exhaust gas (see paragraph 4.1.), kg

$M_{TOTW}$  = total mass of diluted exhaust gas over the cycle (see paragraph 4.1.), kg

$K_{H,D}$  = humidity correction factor for diesel engines as determined in paragraph 4.2.

$K_{H,G}$  = humidity correction factor for gas engines as determined in paragraph 4.2

DF = dilution factor as determined in paragraph 4.3.1.1.

#### 4.4. Calculation of the specific emissions

The emissions (g/kWh) must be calculated for all individual components in the following way:

$$\overline{NO_x} = NOx_{mass} / W_{act} \quad (\text{diesel and gas engines})$$

$$\overline{CO} = CO_{mass} / W_{act} \quad (\text{diesel and gas engines})$$

$$\overline{HC} = HC_{mass} / W_{act} \quad (\text{diesel and LPG fuelled gas engines})$$

$$\overline{NMHC} = NMHC_{mass} / W_{act} \quad (\text{NG fuelled gas engines})$$

$$\overline{CH_4} = CH_{4mass} / W_{act} \quad (\text{NG fuelled gas engines})$$

where:

$W_{act}$  = actual cycle work as determined in paragraph 3.9.2., kWh

### 5. CALCULATION OF THE PARTICULATE EMISSION (DIESEL ENGINES ONLY)

#### 5.1. Calculation of the mass flow

The particulate mass (g/test) must be calculated as follows:

$$PT_{mass} = \frac{M_f}{M_{SAM}} * \frac{M_{TOTW}}{1000}$$

where:

$M_f$  = particulate mass sampled over the cycle, mg

$M_{TOTW}$  = total mass of diluted exhaust gas over the cycle as determined in paragraph 4.1., kg

$M_{SAM}$  = mass of diluted exhaust gas taken from the dilution tunnel for collecting particulates, kg

and,

$M_f = M_{f,p} + M_{f,b}$ , if weighed separately, mg

$M_{f,p}$  = particulate mass collected on the primary filter, mg

$M_{f,b}$  = particulate mass collected on the back-up filter, mg

If a double dilution system is used, the mass of the secondary dilution air must be subtracted from the total mass of the double diluted exhaust gas sampled through the particulate filters.

$$M_{SAM} = M_{TOT} - M_{SEC}$$

where:

$M_{TOT}$  = mass of double diluted exhaust gas through particulate filter, kg

$M_{SEC}$  = mass of secondary dilution air, kg

If the particulate background level of the dilution air is determined in accordance with paragraph 3.4., the particulate mass may be background corrected. In this case, the particulate mass (g/test) must be calculated as follows:

$$PT_{mass} = \left[ \frac{M_f}{M_{SAM}} - \left( \frac{M_d}{M_{DIL}} * \left( 1 - \frac{1}{DF} \right) \right) \right] * \frac{M_{TOTW}}{1000}$$

where:

$M_f, M_{SAM}, M_{TOTW}$  = see above

$M_{DIL}$  = mass of primary dilution air sampled by background particulate sampler, kg

$M_d$  = mass of the collected background particulates of the primary dilution air, mg

DF = dilution factor as determined in paragraph 4.3.1.1

## 5.2. Calculation of the specific emission

The particulate emission (g/kWh) must be calculated in the following way:

$$\overline{PT} = PT_{mass} / W_{act}$$

where:

$W_{act}$  = actual cycle work as determined in paragraph 3.9.2., kWh.

ANNEX 4- APPENDIX 3

ETC ENGINE DYNAMOMETER SCHEDULE

Time	Norm. Speed	Norm. Torque	Time	Norm. Speed	Norm. Torque	Time	Norm. Speed	Norm. Torque
s	%	%	s	%	%	s	%	%
1	0	0	52	0	0	103	0	0
2	0	0	53	0	0	104	0	0
3	0	0	54	0	0	105	0	0
4	0	0	55	0	0	106	0	0
5	0	0	56	0	0	107	0	0
6	0	0	57	0	0	108	11.6	14.8
7	0	0	58	0	0	109	0	0
8	0	0	59	0	0	110	27.2	74.8
9	0	0	60	0	0	111	17	76.9
10	0	0	61	0	0	112	36	78
11	0	0	62	25.5	11.1	113	59.7	86
12	0	0	63	28.5	20.9	114	80.8	17.9
13	0	0	64	32	73.9	115	49.7	0
14	0	0	65	4	82.3	116	65.6	86
15	0	0	66	34.5	80.4	117	78.6	72.2
16	0.1	1.5	67	64.1	86	118	64.9	"m"
17	23.1	21.5	68	58	0	119	44.3	"m"
18	12.6	28.5	69	50.3	83.4	120	51.4	83.4
19	21.8	71	70	66.4	99.1	121	58.1	97
20	19.7	76.8	71	81.4	99.6	122	69.3	99.3
21	54.6	80.9	72	88.7	73.4	123	72	20.8
22	71.3	4.9	73	52.5	0	124	72.1	"m"
23	55.9	18.1	74	46.4	58.5	125	65.3	"m"
24	72	85.4	75	48.6	90.9	126	64	"m"
25	86.7	61.8	76	55.2	99.4	127	59.7	"m"
26	51.7	0	77	62.3	99	128	52.8	"m"
27	53.4	48.9	78	68.4	91.5	129	45.9	"m"
28	34.2	87.6	79	74.5	73.7	130	38.7	"m"
29	45.5	92.7	80	38	0	131	32.4	"m"
30	54.6	99.5	81	41.8	89.6	132	27	"m"
31	64.5	96.8	82	47.1	99.2	133	21.7	"m"
32	71.7	85.4	83	52.5	99.8	134	19.1	0.4
33	79.4	54.8	84	56.9	80.8	135	34.7	14
34	89.7	99.4	85	58.3	11.8	136	16.4	48.6
35	57.4	0	86	56.2	"m"	137	0	11.2
36	59.7	30.6	87	52	"m"	138	1.2	2.1
37	90.1	"m"	88	43.3	"m"	139	30.1	19.3
38	82.9	"m"	89	36.1	"m"	140	30	73.9
39	51.3	"m"	90	27.6	"m"	141	54.4	74.4
40	28.5	"m"	91	21.1	"m"	142	77.2	55.6
41	29.3	"m"	92	8	0	143	58.1	0
42	26.7	"m"	93	0	0	144	45	82.1
43	20.4	"m"	94	0	0	145	68.7	98.1
44	14.1	0	95	0	0	146	85.7	67.2
45	6.5	0	96	0	0	147	60.2	0
46	0	0	97	0	0	148	59.4	98
47	0	0	98	0	0	149	72.7	99.6
48	0	0	99	0	0	150	79.9	45
49	0	0	100	0	0	151	44.3	0
50	0	0	101	0	0	152	41.5	84.4
51	0	0	102	0	0	153	56.2	98.2

Time	Norm. Speed	Norm. Torque	Time	Norm. Speed	Norm. Torque	Time	Norm. Speed	Norm. Torque
s	%	%	s	%	%	s	%	%
154	65.7	99.1	205	0	0	256	51.7	17
155	74.4	84.7	206	0	0	257	56.2	78.7
156	54.4	0	207	0	0	258	59.5	94.7
157	47.9	89.7	208	0	0	259	65.5	99.1
158	54.5	99.5	209	0	0	260	71.2	99.5
159	62.7	96.8	210	0	0	261	76.6	99.9
160	62.3	0	211	0	0	262	79	0
161	46.2	54.2	212	0	0	263	52.9	97.5
162	44.3	83.2	213	0	0	264	53.1	99.7
163	48.2	13.3	214	0	0	265	59	99.1
164	51	"m"	215	0	0	266	62.2	99
165	50	"m"	216	0	0	267	65	99.1
166	49.2	"m"	217	0	0	268	69	83.1
167	49.3	"m"	218	0	0	269	69.9	28.4
168	49.9	"m"	219	0	0	270	70.6	12.5
169	51.6	"m"	220	0	0	271	68.9	8.4
170	49.7	"m"	221	0	0	272	69.8	9.1
171	48.5	"m"	222	0	0	273	69.6	7
172	50.3	72.5	223	0	0	274	65.7	"m"
173	51.1	84.5	224	0	0	275	67.1	"m"
174	54.6	64.8	225	21.2	62.7	276	66.7	"m"
175	56.6	76.5	226	30.8	75.1	277	65.6	"m"
176	58	"m"	227	5.9	82.7	278	64.5	"m"
177	53.6	"m"	228	34.6	80.3	279	62.9	"m"
178	40.8	"m"	229	59.9	87	280	59.3	"m"
179	32.9	"m"	230	84.3	86.2	281	54.1	"m"
180	26.3	"m"	231	68.7	"m"	282	51.3	"m"
181	20.9	"m"	232	43.6	"m"	283	47.9	"m"
182	10	0	233	41.5	85.4	284	43.6	"m"
183	0	0	234	49.9	94.3	285	39.4	"m"
184	0	0	235	60.8	99	286	34.7	"m"
185	0	0	236	70.2	99.4	287	29.8	"m"
186	0	0	237	81.1	92.4	288	20.9	73.4
187	0	0	238	49.2	0	289	36.9	"m"
188	0	0	239	56	86.2	290	35.5	"m"
189	0	0	240	56.2	99.3	291	20.9	"m"
190	0	0	241	61.7	99	292	49.7	11.9
191	0	0	242	69.2	99.3	293	42.5	"m"
192	0	0	243	74.1	99.8	294	32	"m"
193	0	0	244	72.4	8.4	295	23.6	"m"
194	0	0	245	71.3	0	296	19.1	0
195	0	0	246	71.2	9.1	297	15.7	73.5
196	0	0	247	67.1	"m"	298	25.1	76.8
197	0	0	248	65.5	"m"	299	34.5	81.4
198	0	0	249	64.4	"m"	300	44.1	87.4
199	0	0	250	62.9	25.6	301	52.8	98.6
200	0	0	251	62.2	35.6	302	63.6	99
201	0	0	252	62.9	24.4	303	73.6	99.7
202	0	0	253	58.8	"m"	304	62.2	"m"
203	0	0	254	56.9	"m"	305	29.2	"m"
204	0	0	255	54.5	"m"	306	46.4	22

Time	Norm. Speed	Norm. Torque	Time	Norm. Speed	Norm. Torque	Time	Norm. Speed	Norm. Torque
s	%	%	s	%	%	s	%	%
307	47.3	13.8	358	72.6	99.6	409	56.3	72.3
308	47.2	12.5	359	82.4	99.5	410	59.7	99.1
309	47.9	11.5	360	88	99.4	411	62.3	99
310	47.8	35.5	361	46.4	0	412	67.9	99.2
311	49.2	83.3	362	53.4	95.2	413	69.5	99.3
312	52.7	96.4	363	58.4	99.2	414	73.1	99.7
313	57.4	99.2	364	61.5	99	415	77.7	99.8
314	61.8	99	365	64.8	99	416	79.7	99.7
315	66.4	60.9	366	68.1	99.2	417	82.5	99.5
316	65.8	"m"	367	73.4	99.7	418	85.3	99.4
317	59	"m"	368	73.3	29.8	419	86.6	99.4
318	50.7	"m"	369	73.5	14.6	420	89.4	99.4
319	41.8	"m"	370	68.3	0	421	62.2	0
320	34.7	"m"	371	45.4	49.9	422	52.7	96.4
321	28.7	"m"	372	47.2	75.7	423	50.2	99.8
322	25.2	"m"	373	44.5	9	424	49.3	99.6
323	43	24.8	374	47.8	10.3	425	52.2	99.8
324	38.7	0	375	46.8	15.9	426	51.3	100
325	48.1	31.9	376	46.9	12.7	427	51.3	100
326	40.3	61	377	46.8	8.9	428	51.1	100
327	42.4	52.1	378	46.1	6.2	429	51.1	100
328	46.4	47.7	379	46.1	"m"	430	51.8	99.9
329	46.9	30.7	380	45.5	"m"	431	51.3	100
330	46.1	23.1	381	44.7	"m"	432	51.1	100
331	45.7	23.2	382	43.8	"m"	433	51.3	100
332	45.5	31.9	383	41	"m"	434	52.3	99.8
333	46.4	73.6	384	41.1	6.4	435	52.9	99.7
334	51.3	60.7	385	38	6.3	436	53.8	99.6
335	51.3	51.1	386	35.9	0.3	437	51.7	99.9
336	53.2	46.8	387	33.5	0	438	53.5	99.6
337	53.9	50	388	53.1	48.9	439	52	99.8
338	53.4	52.1	389	48.3	"m"	440	51.7	99.9
339	53.8	45.7	390	49.9	"m"	441	53.2	99.7
340	50.6	22.1	391	48	"m"	442	54.2	99.5
341	47.8	26	392	45.3	"m"	443	55.2	99.4
342	41.6	17.8	393	41.6	3.1	444	53.8	99.6
343	38.7	29.8	394	44.3	79	445	53.1	99.7
344	35.9	71.6	395	44.3	89.5	446	55	99.4
345	34.6	47.3	396	43.4	98.8	447	57	99.2
346	34.8	80.3	397	44.3	98.9	448	61.5	99
347	35.9	87.2	398	43	98.8	449	59.4	5.7
348	38.8	90.8	399	42.2	98.8	450	59	0
349	41.5	94.7	400	42.7	98.8	451	57.3	59.8
350	47.1	99.2	401	45	99	452	64.1	99
351	53.1	99.7	402	43.6	98.9	453	70.9	90.5
352	46.4	0	403	42.2	98.8	454	58	0
353	42.5	0.7	404	44.8	99	455	41.5	59.8
354	43.6	58.6	405	43.4	98.8	456	44.1	92.6
355	47.1	87.5	406	45	99	457	46.8	99.2
356	54.1	99.5	407	42.2	54.3	458	47.2	99.3
357	62.9	99	408	61.2	31.9	459	51	100

Time	Norm.	Norm.	Time	Norm.	Norm.	Time	Norm.	Norm.
s	Speed	Torque	s	Speed	Torque	s	Speed	Torque
	%	%		%	%		%	%
460	53.2	99.7	511	0	0	562	58.7	"m"
461	53.1	99.7	512	0	0	563	56	"m"
462	55.9	53.1	513	0	0	564	53.9	"m"
463	53.9	13.9	514	30.5	25.6	565	52.1	"m"
464	52.5	"m"	515	19.7	56.9	566	49.9	"m"
465	51.7	"m"	516	16.3	45.1	567	46.4	"m"
466	51.5	52.2	517	27.2	4.6	568	43.6	"m"
467	52.8	80	518	21.7	1.3	569	40.8	"m"
468	54.9	95	519	29.7	28.6	570	37.5	"m"
469	57.3	99.2	520	36.6	73.7	571	27.8	"m"
470	60.7	99.1	521	61.3	59.5	572	17.1	0.6
471	62.4	"m"	522	40.8	0	573	12.2	0.9
472	60.1	"m"	523	36.6	27.8	574	11.5	1.1
473	53.2	"m"	524	39.4	80.4	575	8.7	0.5
474	44	"m"	525	51.3	88.9	576	8	0.9
475	35.2	"m"	526	58.5	11.1	577	5.3	0.2
476	30.5	"m"	527	60.7	"m"	578	4	0
477	26.5	"m"	528	54.5	"m"	579	3.9	0
478	22.5	"m"	529	51.3	"m"	580	0	0
479	20.4	"m"	530	45.5	"m"	581	0	0
480	19.1	"m"	531	40.8	"m"	582	0	0
481	19.1	"m"	532	38.9	"m"	583	0	0
482	13.4	"m"	533	36.6	"m"	584	0	0
483	6.7	"m"	534	36.1	72.7	585	0	0
484	3.2	"m"	535	44.8	78.9	586	0	0
485	14.3	63.8	536	51.6	91.1	587	8.7	22.8
486	34.1	0	537	59.1	99.1	588	16.2	49.4
487	23.9	75.7	538	66	99.1	589	23.6	56
488	31.7	79.2	539	75.1	99.9	590	21.1	56.1
489	32.1	19.4	540	81	8	591	23.6	56
490	35.9	5.8	541	39.1	0	592	46.2	68.8
491	36.6	0.8	542	53.8	89.7	593	68.4	61.2
492	38.7	"m"	543	59.7	99.1	594	58.7	"m"
493	38.4	"m"	544	64.8	99	595	31.6	"m"
494	39.4	"m"	545	70.6	96.1	596	19.9	8.8
495	39.7	"m"	546	72.6	19.6	597	32.9	70.2
496	40.5	"m"	547	72	6.3	598	43	79
497	40.8	"m"	548	68.9	0.1	599	57.4	98.9
498	39.7	"m"	549	67.7	"m"	600	72.1	73.8
499	39.2	"m"	550	66.8	"m"	601	53	0
500	38.7	"m"	551	64.3	16.9	602	48.1	86
501	32.7	"m"	552	64.9	7	603	56.2	99
502	30.1	"m"	553	63.6	12.5	604	65.4	98.9
503	21.9	"m"	554	63	7.7	605	72.9	99.7
504	12.8	0	555	64.4	38.2	606	67.5	"m"
505	0	0	556	63	11.8	607	39	"m"
506	0	0	557	63.6	0	608	41.9	38.1
507	0	0	558	63.3	5	609	44.1	80.4
508	0	0	559	60.1	9.1	610	46.8	99.4
509	0	0	560	61	8.4	611	48.7	99.9
510	0	0	561	59.7	0.9	612	50.5	99.7



Time	Norm. Speed	Norm. Torque	Time	Norm. Speed	Norm. Torque	Time	Norm. Speed	Norm. Torque
s	%	%	s	%	%	s	%	%
613	52.5	90.3	664	54	39.3	715	46.2	"m"
614	51	1.8	665	53.8	"m"	716	45.6	9.8
615	50	"m"	666	52	"m"	717	45.6	34.5
616	49.1	"m"	667	50.4	"m"	718	45.5	37.1
617	47	"m"	668	50.6	0	719	43.8	"m"
618	43.1	"m"	669	49.3	41.7	720	41.9	"m"
619	39.2	"m"	670	50	73.2	721	41.3	"m"
620	40.6	0.5	671	50.4	99.7	722	41.4	"m"
621	41.8	53.4	672	51.9	99.5	723	41.2	"m"
622	44.4	65.1	673	53.6	99.3	724	41.8	"m"
623	48.1	67.8	674	54.6	99.1	725	41.8	"m"
624	53.8	99.2	675	56	99	726	43.2	17.4
625	58.6	98.9	676	55.8	99	727	45	29
626	63.6	98.8	677	58.4	98.9	728	44.2	"m"
627	68.5	99.2	678	59.9	98.8	729	43.9	"m"
628	72.2	89.4	679	60.9	98.8	730	38	10.7
629	77.1	0	680	63	98.8	731	56.8	"m"
630	57.8	79.1	681	64.3	98.9	732	57.1	"m"
631	60.3	98.8	682	64.8	64	733	52	"m"
632	61.9	98.8	683	65.9	46.5	734	44.4	"m"
633	63.8	98.8	684	66.2	28.7	735	40.2	"m"
634	64.7	98.9	685	65.2	1.8	736	39.2	16.5
635	65.4	46.5	686	65	6.8	737	38.9	73.2
636	65.7	44.5	687	63.6	53.6	738	39.9	89.8
637	65.6	3.5	688	62.4	82.5	739	42.3	98.6
638	49.1	0	689	61.8	98.8	740	43.7	98.8
639	50.4	73.1	690	59.8	98.8	741	45.5	99.1
640	50.5	"m"	691	59.2	98.8	742	45.6	99.2
641	51	"m"	692	59.7	98.8	743	48.1	99.7
642	49.4	"m"	693	61.2	98.8	744	49	100
643	49.2	"m"	694	62.2	49.4	745	49.8	99.9
644	48.6	"m"	695	62.8	37.2	746	49.8	99.9
645	47.5	"m"	696	63.5	46.3	747	51.9	99.5
646	46.5	"m"	697	64.7	72.3	748	52.3	99.4
647	46	11.3	698	64.7	72.3	749	53.3	99.3
648	45.6	42.8	699	65.4	77.4	750	52.9	99.3
649	47.1	83	700	66.1	69.3	751	54.3	99.2
650	46.2	99.3	701	64.3	"m"	752	55.5	99.1
651	47.9	99.7	702	64.3	"m"	753	56.7	99
652	49.5	99.9	703	63	"m"	754	61.7	98.8
653	50.6	99.7	704	62.2	"m"	755	64.3	47.4
654	51	99.6	705	61.6	"m"	756	64.7	1.8
655	53	99.3	706	62.4	"m"	757	66.2	"m"
656	54.9	99.1	707	62.2	"m"	758	49.1	"m"
657	55.7	99	708	61	"m"	759	52.1	46
658	56	99	709	58.7	"m"	760	52.6	61
659	56.1	9.3	710	55.5	"m"	761	52.9	0
660	55.6	"m"	711	51.7	"m"	762	52.3	20.4
661	55.4	"m"	712	49.2	"m"	763	54.2	56.7
662	54.9	51.3	713	48.8	40.4	764	55.4	59.8
663	54.9	59.8	714	47.9	"m"	765	56.1	49.2

Time	Norm.	Norm.	Time	Norm.	Norm.	Time	Norm.	Norm.
s	Speed	Torque	s	Speed	Torque	s	Speed	Torque
	%	%		%	%		%	%
766	56.8	33.7	817	61.7	46.2	868	53	99.3
767	57.2	96	818	59.8	45.1	869	54.2	99.2
768	58.6	98.9	819	57.4	43.9	870	55.5	99.1
769	59.5	98.8	820	54.8	42.8	871	56.7	99
770	61.2	98.8	821	54.3	65.2	872	57.3	98.9
771	62.1	98.8	822	52.9	62.1	873	58	98.9
772	62.7	98.8	823	52.4	30.6	874	60.5	31.1
773	62.8	98.8	824	50.4	"m"	875	60.2	"m"
774	64	98.9	825	48.6	"m"	876	60.3	"m"
775	63.2	46.3	826	47.9	"m"	877	60.5	6.3
776	62.4	"m"	827	46.8	"m"	878	61.4	19.3
777	60.3	"m"	828	46.9	9.4	879	60.3	1.2
778	58.7	"m"	829	49.5	41.7	880	60.5	2.9
779	57.2	"m"	830	50.5	37.8	881	61.2	34.1
780	56.1	"m"	831	52.3	20.4	882	61.6	13.2
781	56	9.3	832	54.1	30.7	883	61.5	16.4
782	55.2	26.3	833	56.3	41.8	884	61.2	16.4
783	54.8	42.8	834	58.7	26.5	885	61.3	"m"
784	55.7	47.1	835	57.3	"m"	886	63.1	"m"
785	56.6	52.4	836	59	"m"	887	63.2	4.8
786	58	50.3	837	59.8	"m"	888	62.3	22.3
787	58.6	20.6	838	60.3	"m"	889	62	38.5
788	58.7	"m"	839	61.2	"m"	890	61.6	29.6
789	59.3	"m"	840	61.8	"m"	891	61.6	26.6
790	58.6	"m"	841	62.5	"m"	892	61.8	28.1
791	60.5	9.7	842	62.4	"m"	893	62	29.6
792	59.2	9.6	843	61.5	"m"	894	62	16.3
793	59.9	9.6	844	63.7	"m"	895	61.1	"m"
794	59.6	9.6	845	61.9	"m"	896	61.2	"m"
795	59.9	6.2	846	61.6	29.7	897	60.7	19.2
796	59.9	9.6	847	60.3	"m"	898	60.7	32.5
797	60.5	13.1	848	59.2	"m"	899	60.9	17.8
798	60.3	20.7	849	57.3	"m"	900	60.1	19.2
799	59.9	31	850	52.3	"m"	901	59.3	38.2
800	60.5	42	851	49.3	"m"	902	59.9	45
801	61.5	52.5	852	47.3	"m"	903	59.4	32.4
802	60.9	51.4	853	46.3	38.8	904	59.2	23.5
803	61.2	57.7	854	46.8	35.1	905	59.5	40.8
804	62.8	98.8	855	46.6	"m"	906	58.3	"m"
805	63.4	96.1	856	44.3	"m"	907	58.2	"m"
806	64.6	45.4	857	43.1	"m"	908	57.6	"m"
807	64.1	5	858	42.4	2.1	909	57.1	"m"
808	63	3.2	859	41.8	2.4	910	57	0.6
809	62.7	14.9	860	43.8	68.8	911	57	26.3
810	63.5	35.8	861	44.6	89.2	912	56.5	29.2
811	64.1	73.3	862	46	99.2	913	56.3	20.5
812	64.3	37.4	863	46.9	99.4	914	56.1	"m"
813	64.1	21	864	47.9	99.7	915	55.2	"m"
814	63.7	21	865	50.2	99.8	916	54.7	17.5
815	62.9	18	866	51.2	99.6	917	55.2	29.2
816	62.4	32.7	867	52.3	99.4	918	55.2	29.2

Time	Norm. Speed	Norm. Torque	Time	Norm. Speed	Norm. Torque	Time	Norm. Speed	Norm. Torque
s	%	%	s	%	%	s	%	%
919	55.9	16	970	49.9	99.7	1021	49.4	"m"
920	55.9	26.3	971	49.6	99.6	1022	48.3	"m"
921	56.1	36.5	972	49.4	99.6	1023	49.4	"m"
922	55.8	19	973	49	99.5	1024	48.5	"m"
923	55.9	9.2	974	49.8	99.7	1025	48.7	"m"
924	55.8	21.9	975	50.9	100	1026	48.7	"m"
925	56.4	42.8	976	50.4	99.8	1027	49.1	"m"
926	56.4	38	977	49.8	99.7	1028	49	"m"
927	56.4	11	978	49.1	99.5	1029	49.8	"m"
928	56.4	35.1	979	50.4	99.8	1030	48.7	"m"
929	54	7.3	980	49.8	99.7	1031	48.5	"m"
930	53.4	5.4	981	49.3	99.5	1032	49.3	31.3
931	52.3	27.6	982	49.1	99.5	1033	49.7	45.3
932	52.1	32	983	49.9	99.7	1034	48.3	44.5
933	52.3	33.4	984	49.1	99.5	1035	49.8	61
934	52.2	34.9	985	50.4	99.8	1036	49.4	64.3
935	52.8	60.1	986	50.9	100	1037	49.8	64.4
936	53.7	69.7	987	51.4	99.9	1038	50.5	65.6
937	54	70.7	988	51.5	99.9	1039	50.3	64.5
938	55.1	71.7	989	52.2	99.7	1040	51.2	82.9
939	55.2	46	990	52.8	74.1	1041	50.5	86
940	54.7	12.6	991	53.3	46	1042	50.6	89
941	52.5	0	992	53.6	36.4	1043	50.4	81.4
942	51.8	24.7	993	53.4	33.5	1044	49.9	49.9
943	51.4	43.9	994	53.9	58.9	1045	49.1	20.1
944	50.9	71.1	995	55.2	73.8	1046	47.9	24
945	51.2	76.8	996	55.8	52.4	1047	48.1	36.2
946	50.3	87.5	997	55.7	9.2	1048	47.5	34.5
947	50.2	99.8	998	55.8	2.2	1049	46.9	30.3
948	50.9	100	999	56.4	33.6	1050	47.7	53.5
949	49.9	99.7	1000	55.4	"m"	1051	46.9	61.6
950	50.9	100	1001	55.2	"m"	1052	46.5	73.6
951	49.8	99.7	1002	55.8	26.3	1053	48	84.6
952	50.4	99.8	1003	55.8	23.3	1054	47.2	87.7
953	50.4	99.8	1004	56.4	50.2	1055	48.7	80
954	49.7	99.7	1005	57.6	68.3	1056	48.7	50.4
955	51	100	1006	58.8	90.2	1057	47.8	38.6
956	50.3	99.8	1007	59.9	98.9	1058	48.8	63.1
957	50.2	99.8	1008	62.3	98.8	1059	47.4	5
958	49.9	99.7	1009	63.1	74.4	1060	47.3	47.4
959	50.9	100	1010	63.7	49.4	1061	47.3	49.8
960	50	99.7	1011	63.3	9.8	1062	46.9	23.9
961	50.2	99.8	1012	48	0	1063	46.7	44.6
962	50.2	99.8	1013	47.9	73.5	1064	46.8	65.2
963	49.9	99.7	1014	49.9	99.7	1065	46.9	60.4
964	50.4	99.8	1015	49.9	48.8	1066	46.7	61.5
965	50.2	99.8	1016	49.6	2.3	1067	45.5	"m"
966	50.3	99.8	1017	49.9	"m"	1068	45.5	"m"
967	49.9	99.7	1018	49.3	"m"	1069	44.2	"m"
968	51.1	100	1019	49.7	47.5	1070	43	"m"
969	50.6	99.9	1020	49.1	"m"	1071	42.5	"m"

Time	Norm.	Norm.	Time	Norm.	Norm.	Time	Norm.	Norm.
s	Speed	Torque	s	Speed	Torque	s	Speed	Torque
	%	%		%	%		%	%
1072	41	"m"	1123	55	"m"	1174	56.9	"m"
1073	39.9	"m"	1124	53.7	"m"	1175	56.4	4
1074	39.9	38.2	1125	52.1	"m"	1176	57	23.4
1075	40.1	48.1	1126	51.1	"m"	1177	56.4	41.7
1076	39.9	48	1127	49.7	25.8	1178	57	49.2
1077	39.4	59.3	1128	49.1	46.1	1179	57.7	56.6
1078	43.8	19.8	1129	48.7	46.9	1180	58.6	56.6
1079	52.9	0	1130	48.2	46.7	1181	58.9	64
1080	52.8	88.9	1131	48	70	1182	59.4	68.2
1081	53.4	99.5	1132	48	70	1183	58.8	71.4
1082	54.7	99.3	1133	47.2	67.6	1184	60.1	71.3
1083	56.3	99.1	1134	47.3	67.6	1185	60.6	79.1
1084	57.5	99	1135	46.6	74.7	1186	60.7	83.3
1085	59	98.9	1136	47.4	13	1187	60.7	77.1
1086	59.8	98.9	1137	46.3	"m"	1188	60	73.5
1087	60.1	98.9	1138	45.4	"m"	1189	60.2	55.5
1088	61.8	48.3	1139	45.5	24.8	1190	59.7	54.4
1089	61.8	55.6	1140	44.8	73.8	1191	59.8	73.3
1090	61.7	59.8	1141	46.6	99	1192	59.8	77.9
1091	62	55.6	1142	46.3	98.9	1193	59.8	73.9
1092	62.3	29.6	1143	48.5	99.4	1194	60	76.5
1093	62	19.3	1144	49.9	99.7	1195	59.5	82.3
1094	61.3	7.9	1145	49.1	99.5	1196	59.9	82.8
1095	61.1	19.2	1146	49.1	99.5	1197	59.8	65.8
1096	61.2	43	1147	51	100	1198	59	48.6
1097	61.1	59.7	1148	51.5	99.9	1199	58.9	62.2
1098	61.1	98.8	1149	50.9	100	1200	59.1	70.4
1099	61.3	98.8	1150	51.6	99.9	1201	58.9	62.1
1100	61.3	26.6	1151	52.1	99.7	1202	58.4	67.4
1101	60.4	"m"	1152	50.9	100	1203	58.7	58.9
1102	58.8	"m"	1153	52.2	99.7	1204	58.3	57.7
1103	57.7	"m"	1154	51.5	98.3	1205	57.5	57.8
1104	56	"m"	1155	51.5	47.2	1206	57.2	57.6
1105	54.7	"m"	1156	50.8	78.4	1207	57.1	42.6
1106	53.3	"m"	1157	50.3	83	1208	57	70.1
1107	52.6	23.2	1158	50.3	31.7	1209	56.4	59.6
1108	53.4	84.2	1159	49.3	31.3	1210	56.7	39
1109	53.9	99.4	1160	48.8	21.5	1211	55.9	68.1
1110	54.9	99.3	1161	47.8	59.4	1212	56.3	79.1
1111	55.8	99.2	1162	48.1	77.1	1213	56.7	89.7
1112	57.1	99	1163	48.4	87.6	1214	56	89.4
1113	56.5	99.1	1164	49.6	87.5	1215	56	93.1
1114	58.9	98.9	1165	51	81.4	1216	56.4	93.1
1115	58.7	98.9	1166	51.6	66.7	1217	56.7	94.4
1116	59.8	98.9	1167	53.3	63.2	1218	56.9	94.8
1117	61	98.8	1168	55.2	62	1219	57	94.1
1118	60.7	19.2	1169	55.7	43.9	1220	57.7	94.3
1119	59.4	"m"	1170	56.4	30.7	1221	57.5	93.7
1120	57.9	"m"	1171	56.8	23.4	1222	58.4	93.2
1121	57.6	"m"	1172	57	"m"	1223	58.7	93.2
1122	56.3	"m"	1173	57.6	"m"	1224	58.2	93.7

Time	Norm. Speed	Norm. Torque	Time	Norm. Speed	Norm. Torque	Time	Norm. Speed	Norm. Torque
s	%	%	s	%	%	s	%	%
1225	58.5	93.1	1276	60.6	5.5	1327	63.1	20.3
1226	58.8	86.2	1277	61	14.3	1328	61.8	19.1
1227	59	72.9	1278	61	12	1329	61.6	17.1
1228	58.2	59.9	1279	61.3	34.2	1330	61	0
1229	57.6	8.5	1280	61.2	17.1	1331	61.2	22
1230	57.1	47.6	1281	61.5	15.7	1332	60.8	40.3
1231	57.2	74.4	1282	61	9.5	1333	61.1	34.3
1232	57	79.1	1283	61.1	9.2	1334	60.7	16.1
1233	56.7	67.2	1284	60.5	4.3	1335	60.6	16.6
1234	56.8	69.1	1285	60.2	7.8	1336	60.5	18.5
1235	56.9	71.3	1286	60.2	5.9	1337	60.6	29.8
1236	57	77.3	1287	60.2	5.3	1338	60.9	19.5
1237	57.4	78.2	1288	59.9	4.6	1339	60.9	22.3
1238	57.3	70.6	1289	59.4	21.5	1340	61.4	35.8
1239	57.7	64	1290	59.6	15.8	1341	61.3	42.9
1240	57.5	55.6	1291	59.3	10.1	1342	61.5	31
1241	58.6	49.6	1292	58.9	9.4	1343	61.3	19.2
1242	58.2	41.1	1293	58.8	9	1344	61	9.3
1243	58.8	40.6	1294	58.9	35.4	1345	60.8	44.2
1244	58.3	21.1	1295	58.9	30.7	1346	60.9	55.3
1245	58.7	24.9	1296	58.9	25.9	1347	61.2	56
1246	59.1	24.8	1297	58.7	22.9	1348	60.9	60.1
1247	58.6	"m"	1298	58.7	24.4	1349	60.7	59.1
1248	58.8	"m"	1299	59.3	61	1350	60.9	56.8
1249	58.8	"m"	1300	60.1	56	1351	60.7	58.1
1250	58.7	"m"	1301	60.5	50.6	1352	59.6	78.4
1251	59.1	"m"	1302	59.5	16.2	1353	59.6	84.6
1252	59.1	"m"	1303	59.7	50	1354	59.4	66.6
1253	59.4	"m"	1304	59.7	31.4	1355	59.3	75.5
1254	60.6	2.6	1305	60.1	43.1	1356	58.9	49.6
1255	59.6	"m"	1306	60.8	38.4	1357	59.1	75.8
1256	60.1	"m"	1307	60.9	40.2	1358	59	77.6
1257	60.6	"m"	1308	61.3	49.7	1359	59	67.8
1258	59.6	4.1	1309	61.8	45.9	1360	59	56.7
1259	60.7	7.1	1310	62	45.9	1361	58.8	54.2
1260	60.5	"m"	1311	62.2	45.8	1362	58.9	59.6
1261	59.7	"m"	1312	62.6	46.8	1363	58.9	60.8
1262	59.6	"m"	1313	62.7	44.3	1364	59.3	56.1
1263	59.8	"m"	1314	62.9	44.4	1365	58.9	48.5
1264	59.6	4.9	1315	63.1	43.7	1366	59.3	42.9
1265	60.1	5.9	1316	63.5	46.1	1367	59.4	41.4
1266	59.9	6.1	1317	63.6	40.7	1368	59.6	38.9
1267	59.7	"m"	1318	64.3	49.5	1369	59.4	32.9
1268	59.6	"m"	1319	63.7	27	1370	59.3	30.6
1269	59.7	22	1320	63.8	15	1371	59.4	30
1270	59.8	10.3	1321	63.6	18.7	1372	59.4	25.3
1271	59.9	10	1322	63.4	8.4	1373	58.8	18.6
1272	60.6	6.2	1323	63.2	8.7	1374	59.1	18
1273	60.5	7.3	1324	63.3	21.6	1375	58.5	10.6
1274	60.2	14.8	1325	62.9	19.7	1376	58.8	10.5
1275	60.6	8.2	1326	63	22.1	1377	58.5	8.2

Time	Norm.	Norm.	Time	Norm.	Norm.	Time	Norm.	Norm.
s	Speed	Torque	s	Speed	Torque	s	Speed	Torque
	%	%		%	%		%	%
1378	58.7	13.7	1429	62.3	37.4	1480	60.1	4.7
1379	59.1	7.8	1430	62.3	35.7	1481	59.9	0
1380	59.1	6	1431	62.8	34.4	1482	60.4	36.2
1381	59.1	6	1432	62.8	31.5	1483	60.7	32.5
1382	59.4	13.1	1433	62.9	31.7	1484	59.9	3.1
1383	59.7	22.3	1434	62.9	29.9	1485	59.7	"m"
1384	60.7	10.5	1435	62.8	29.4	1486	59.5	"m"
1385	59.8	9.8	1436	62.7	28.7	1487	59.2	"m"
1386	60.2	8.8	1437	61.5	14.7	1488	58.8	0.6
1387	59.9	8.7	1438	61.9	17.2	1489	58.7	"m"
1388	61	9.1	1439	61.5	6.1	1490	58.7	"m"
1389	60.6	28.2	1440	61	9.9	1491	57.9	"m"
1390	60.6	22	1441	60.9	4.8	1492	58.2	"m"
1391	59.6	23.2	1442	60.6	11.1	1493	57.6	"m"
1392	59.6	19	1443	60.3	6.9	1494	58.3	9.5
1393	60.6	38.4	1444	60.8	7	1495	57.2	6
1394	59.8	41.6	1445	60.2	9.2	1496	57.4	27.3
1395	60	47.3	1446	60.5	21.7	1497	58.3	59.9
1396	60.5	55.4	1447	60.2	22.4	1498	58.3	7.3
1397	60.9	58.7	1448	60.7	31.6	1499	58.8	21.7
1398	61.3	37.9	1449	60.9	28.9	1500	58.8	38.9
1399	61.2	38.3	1450	59.6	21.7	1501	59.4	26.2
1400	61.4	58.7	1451	60.2	18	1502	59.1	25.5
1401	61.3	51.3	1452	59.5	16.7	1503	59.1	26
1402	61.4	71.1	1453	59.8	15.7	1504	59	39.1
1403	61.1	51	1454	59.6	15.7	1505	59.5	52.3
1404	61.5	56.6	1455	59.3	15.7	1506	59.4	31
1405	61	60.6	1456	59	7.5	1507	59.4	27
1406	61.1	75.4	1457	58.8	7.1	1508	59.4	29.8
1407	61.4	69.4	1458	58.7	16.5	1509	59.4	23.1
1408	61.6	69.9	1459	59.2	50.7	1510	58.9	16
1409	61.7	59.6	1460	59.7	60.2	1511	59	31.5
1410	61.8	54.8	1461	60.4	44	1512	58.8	25.9
1411	61.6	53.6	1462	60.2	35.3	1513	58.9	40.2
1412	61.3	53.5	1463	60.4	17.1	1514	58.8	28.4
1413	61.3	52.9	1464	59.9	13.5	1515	58.9	38.9
1414	61.2	54.1	1465	59.9	12.8	1516	59.1	35.3
1415	61.3	53.2	1466	59.6	14.8	1517	58.8	30.3
1416	61.2	52.2	1467	59.4	15.9	1518	59	19
1417	61.2	52.3	1468	59.4	22	1519	58.7	3
1418	61	48	1469	60.4	38.4	1520	57.9	0
1419	60.9	41.5	1470	59.5	38.8	1521	58	2.4
1420	61	32.2	1471	59.3	31.9	1522	57.1	"m"
1421	60.7	22	1472	60.9	40.8	1523	56.7	"m"
1422	60.7	23.3	1473	60.7	39	1524	56.7	5.3
1423	60.8	38.8	1474	60.9	30.1	1525	56.6	2.1
1424	61	40.7	1475	61	29.3	1526	56.8	"m"
1425	61	30.6	1476	60.6	28.4	1527	56.3	"m"
1426	61.3	62.6	1477	60.9	36.3	1528	56.3	"m"
1427	61.7	55.9	1478	60.8	30.5	1529	56	"m"
1428	62.3	43.4	1479	60.7	26.7	1530	56.7	"m"

Time	Norm. Speed	Norm. Torque	Time	Norm. Speed	Norm. Torque	Time	Norm. Speed	Norm. Torque
s	%	%	s	%	%	s	%	%
1531	56.6	3.8	1582	59.9	73.6	1633	62.5	31
1532	56.9	"m"	1583	59.8	74.1	1634	62.3	31.3
1533	56.9	"m"	1584	59.6	84.6	1635	62.6	31.7
1534	57.4	"m"	1585	59.4	76.1	1636	62.3	22.8
1535	57.4	"m"	1586	60.1	76.9	1637	62.7	12.6
1536	58.3	13.9	1587	59.5	84.6	1638	62.2	15.2
1537	58.5	"m"	1588	59.8	77.5	1639	61.9	32.6
1538	59.1	"m"	1589	60.6	67.9	1640	62.5	23.1
1539	59.4	"m"	1590	59.3	47.3	1641	61.7	19.4
1540	59.6	"m"	1591	59.3	43.1	1642	61.7	10.8
1541	59.5	"m"	1592	59.4	38.3	1643	61.6	10.2
1542	59.6	0.5	1593	58.7	38.2	1644	61.4	"m"
1543	59.3	9.2	1594	58.8	39.2	1645	60.8	"m"
1544	59.4	11.2	1595	59.1	67.9	1646	60.7	"m"
1545	59.1	26.8	1596	59.7	60.5	1647	61	12.4
1546	59	11.7	1597	59.5	32.9	1648	60.4	5.3
1547	58.8	6.4	1598	59.6	20	1649	61	13.1
1548	58.7	5	1599	59.6	34.4	1650	60.7	29.6
1549	57.5	"m"	1600	59.4	23.9	1651	60.5	28.9
1550	57.4	"m"	1601	59.6	15.7	1652	60.8	27.1
1551	57.1	1.1	1602	59.9	41	1653	61.2	27.3
1552	57.1	0	1603	60.5	26.3	1654	60.9	20.6
1553	57	4.5	1604	59.6	14	1655	61.1	13.9
1554	57.1	3.7	1605	59.7	21.2	1656	60.7	13.4
1555	57.3	3.3	1606	60.9	19.6	1657	61.3	26.1
1556	57.3	16.8	1607	60.1	34.3	1658	60.9	23.7
1557	58.2	29.3	1608	59.9	27	1659	61.4	32.1
1558	58.7	12.5	1609	60.8	25.6	1660	61.7	33.5
1559	58.3	12.2	1610	60.6	26.3	1661	61.8	34.1
1560	58.6	12.7	1611	60.9	26.1	1662	61.7	17
1561	59	13.6	1612	61.1	38	1663	61.7	2.5
1562	59.8	21.9	1613	61.2	31.6	1664	61.5	5.9
1563	59.3	20.9	1614	61.4	30.6	1665	61.3	14.9
1564	59.7	19.2	1615	61.7	29.6	1666	61.5	17.2
1565	60.1	15.9	1616	61.5	28.8	1667	61.1	"m"
1566	60.7	16.7	1617	61.7	27.8	1668	61.4	"m"
1567	60.7	18.1	1618	62.2	20.3	1669	61.4	8.8
1568	60.7	40.6	1619	61.4	19.6	1670	61.3	8.8
1569	60.7	59.7	1620	61.8	19.7	1671	61	18
1570	61.1	66.8	1621	61.8	18.7	1672	61.5	13
1571	61.1	58.8	1622	61.6	17.7	1673	61	3.7
1572	60.8	64.7	1623	61.7	8.7	1674	60.9	3.1
1573	60.1	63.6	1624	61.7	1.4	1675	60.9	4.7
1574	60.7	83.2	1625	61.7	5.9	1676	60.6	4.1
1575	60.4	82.2	1626	61.2	8.1	1677	60.6	6.7
1576	60	80.5	1627	61.9	45.8	1678	60.6	12.8
1577	59.9	78.7	1628	61.4	31.5	1679	60.7	11.9
1578	60.8	67.9	1629	61.7	22.3	1680	60.6	12.4
1579	60.4	57.7	1630	62.4	21.7	1681	60.1	12.4
1580	60.2	60.6	1631	62.8	21.9	1682	60.5	12
1581	59.6	72.7	1632	62.2	22.2	1683	60.4	11.8

Time	Norm.	Norm.	Time	Norm.	Norm.	Time	Norm.	Norm.
s	Speed	Torque	s	Speed	Torque	s	Speed	Torque
	%	%		%	%		%	%
1684	59.9	12.4	1735	61.1	25.6	1786	0	0
1685	59.6	12.4	1736	61	14.6	1787	0	0
1686	59.6	9.1	1737	61	10.4	1788	0	0
1687	59.9	0	1738	60.6	"m"	1789	0	0
1688	59.9	20.4	1739	60.9	"m"	1790	0	0
1689	59.8	4.4	1740	60.8	4.8	1791	0	0
1690	59.4	3.1	1741	59.9	"m"	1792	0	0
1691	59.5	26.3	1742	59.8	"m"	1793	0	0
1692	59.6	20.1	1743	59.1	"m"	1794	0	0
1693	59.4	35	1744	58.8	"m"	1795	0	0
1694	60.9	22.1	1745	58.8	"m"	1796	0	0
1695	60.5	12.2	1746	58.2	"m"	1797	0	0
1696	60.1	11	1747	58.5	14.3	1798	0	0
1697	60.1	8.2	1748	57.5	4.4	1799	0	0
1698	60.5	6.7	1749	57.9	0	1800	0	0
1699	60	5.1	1750	57.8	20.9			
1700	60	5.1	1751	58.3	9.2			
1701	60	9	1752	57.8	8.2			
1702	60.1	5.7	1753	57.5	15.3			
1703	59.9	8.5	1754	58.4	38			
1704	59.4	6	1755	58.1	15.4			
1705	59.5	5.5	1756	58.8	11.8			
1706	59.5	14.2	1757	58.3	8.1			
1707	59.5	6.2	1758	58.3	5.5			
1708	59.4	10.3	1759	59	4.1			
1709	59.6	13.8	1760	58.2	4.9			
1710	59.5	13.9	1761	57.9	10.1			
1711	60.1	18.9	1762	58.5	7.5			
1712	59.4	13.1	1763	57.4	7			
1713	59.8	5.4	1764	58.2	6.7			
1714	59.9	2.9	1765	58.2	6.6			
1715	60.1	7.1	1766	57.3	17.3			
1716	59.6	12	1767	58	11.4			
1717	59.6	4.9	1768	57.5	47.4			
1718	59.4	22.7	1769	57.4	28.8			
1719	59.6	22	1770	58.8	24.3			
1720	60.1	17.4	1771	57.7	25.5			
1721	60.2	16.6	1772	58.4	35.5			
1722	59.4	28.6	1773	58.4	29.3			
1723	60.3	22.4	1774	59	33.8			
1724	59.9	20	1775	59	18.7			
1725	60.2	18.6	1776	58.8	9.8			
1726	60.3	11.9	1777	58.8	23.9			
1727	60.4	11.6	1778	59.1	48.2			
1728	60.6	10.6	1779	59.4	37.2			
1729	60.8	16	1780	59.6	29.1			
1730	60.9	17	1781	50	25			
1731	60.9	16.1	1782	40	20			
1732	60.7	11.4	1783	30	15			
1733	60.9	11.3	1784	20	10			
1734	61.1	11.2	1785	10	5			

"m" = motoring



A graphical display of the ETC dynamometer schedule is shown in Figure 5.

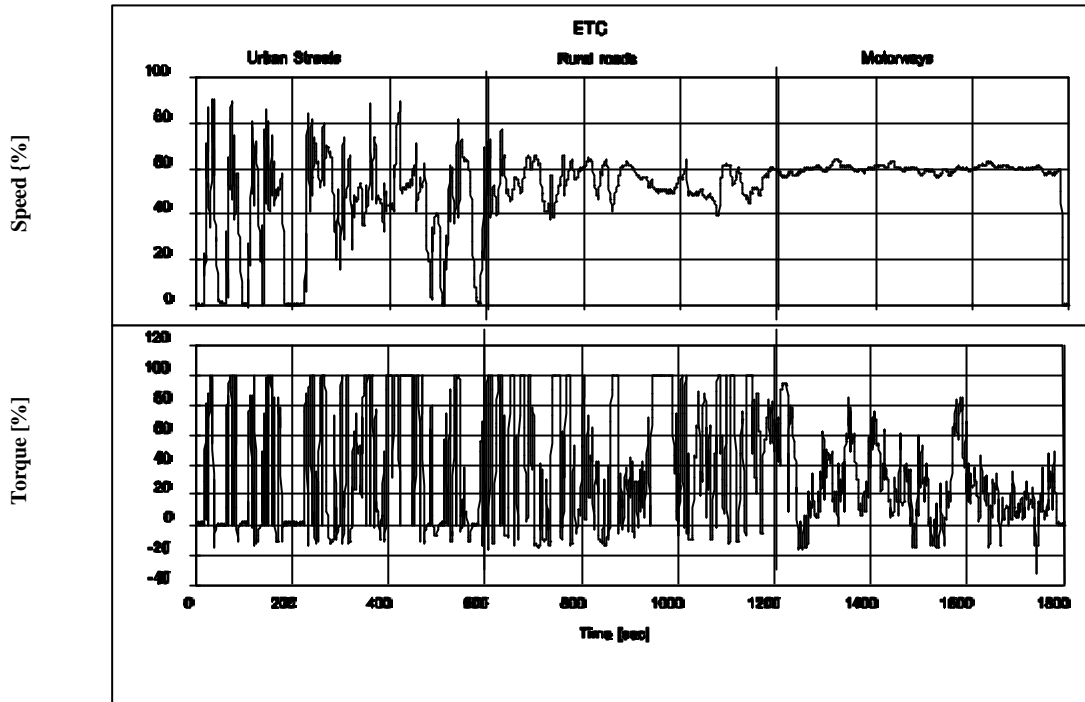

Figure 5: ETC Dynamometer Schedule

\_\_\_\_\_ "

Annex 4 - Appendix 4, amend to read:

"Annex 4 - Appendix 4

MEASUREMENT AND SAMPLING PROCEDURES

1. INTRODUCTION

Gaseous components, particulates, and smoke emitted by the engine submitted for testing must be measured by the methods described in annex 4, appendix 7. The respective paragraphs of annex 4, appendix 7 describe the recommended analytical systems for the gaseous emissions (paragraph 1.), the recommended particulate dilution and sampling systems (paragraph 2.), and the recommended opacimeters for smoke measurement (paragraph 3.).

For the ESC, the gaseous components must be determined in the raw exhaust gas. Optionally, they may be determined in the diluted exhaust gas, if a full flow dilution system is used for particulate determination. Particulates must be determined with either a partial flow or a full flow dilution system.

For the ETC, only a full flow dilution system must be used for determining gaseous and particulate emissions, and is considered the reference system. However, partial flow dilution systems may be approved by the Technical Service, if their equivalency according to paragraph 6.2. to the Regulation is proven, and if a detailed description of the data evaluation and calculation procedures is submitted to the Technical Service.

2. DYNAMOMETER AND TEST CELL EQUIPMENT

The following equipment must be used for emission tests of engines on engine dynamometers.

2.1. Engine dynamometer

An engine dynamometer must be used with adequate characteristics to perform the test cycles described in appendices 1 and 2 to this annex. The speed measuring system must have an accuracy of  $\pm 2$  per cent of reading. The torque measuring system must have an accuracy of  $\pm 3$  per cent of reading in the range  $> 20$  per cent of full scale, and an accuracy of  $\pm 0.6$  per cent of full scale in the range  $\leq 20$  per cent of full scale.

2.2. Other instruments

Measuring instruments for fuel consumption, air consumption, temperature of coolant and lubricant, exhaust gas pressure and intake manifold depression, exhaust gas temperature, air intake temperature, atmospheric pressure, humidity and fuel temperature must be used, as required. These instruments must satisfy the requirements given in table 8:

Table 8: Accuracy of measuring instruments

Measuring instrument	Accuracy
Fuel Consumption	$\pm 2$ % of Engine's Maximum Value
Air Consumption	$\pm 2$ % of Engine's Maximum Value
Temperatures 600 K (327°C)	$\pm 2$ K Absolute
Temperatures 600 K (327°C)	$\pm 1$ % of Reading
Atmospheric Pressure	$\pm 0.1$ kPa Absolute
Exhaust Gas Pressure	$\pm 0.2$ kPa Absolute
Intake Depression	$\pm 0.05$ kPa Absolute
Other Pressures	$\pm 0.1$ kPa Absolute
Relative Humidity	$\pm 3$ % Absolute
Absolute Humidity	$\pm 5$ % of Reading

2.3. Exhaust gas flow

For calculation of the emissions in the raw exhaust, it is necessary to know the exhaust gas flow (see paragraph 4.4. of appendix 1). For the determination of the exhaust flow either of the following methods may be used:

Direct measurement of the exhaust flow by flow nozzle or equivalent metering system;

Measurement of the air flow and the fuel flow by suitable metering systems and calculation of the exhaust flow by the following equation:

$$G_{\text{EXHW}} = G_{\text{AIRW}} + G_{\text{FUEL}} \quad (\text{for wet exhaust mass})$$

The accuracy of exhaust flow determination must be  $\pm 2.5$  per cent of reading or better.

#### 2.4. Diluted exhaust gas flow

For calculation of the emissions in the diluted exhaust using a full flow dilution system (mandatory for the ETC), it is necessary to know the diluted exhaust gas flow (see paragraph 4.3. of appendix 2). The total mass flow rate of the diluted exhaust ( $G_{\text{TOTW}}$ ) or the total mass of the diluted exhaust gas over the cycle ( $M_{\text{TOTW}}$ ) must be measured with a PDP or CFV (annex 4, appendix 7, paragraph 2.3.1.). The accuracy must be  $\pm 2$  per cent of reading or better, and must be determined according to the provisions of annex 4, appendix 5, paragraph 2.4.

### 3. DETERMINATION OF THE GASEOUS COMPONENTS

#### 3.1. General analyser specifications

The analysers must have a measuring range appropriate for the accuracy required to measure the concentrations of the exhaust gas components (paragraph 3.1.1). It is recommended that the analysers be operated such that the measured concentration falls between 15 per cent and 100 per cent of full scale.

If read-out systems (computers, data loggers) can provide sufficient accuracy and resolution below 15 per cent of full scale, measurements below 15 per cent of full scale are also acceptable. In this case, additional calibrations of at least 4 non-zero nominally equally spaced points are to be made to ensure the accuracy of the calibration curves according to annex 4, appendix 5, paragraph 1.5.5.2.

The electromagnetic compatibility (EMC) of the equipment must be on a level as to minimise additional errors.

##### 3.1.1. Measurement error

The total measurement error, including the cross sensitivity to other gases (see annex 4, appendix 5, paragraph 1.9.), must not exceed  $\pm 5$  per cent of the reading or  $\pm 3.5$  per cent of full scale, whichever is smaller. For concentrations of less than 100 ppm the measurement error must not exceed  $\pm 4$  ppm.

3.1.2. Repeatability

The repeatability, defined as 2.5 times the standard deviation of 10 repetitive responses to a given calibration or span gas, has to be not greater than  $\pm 1$  per cent of full scale concentration for each range used above 155 ppm (or ppm C) or  $\pm 2$  per cent of each range used below 155 ppm (or ppm C).

3.1.3. Noise

The analyser peak-to-peak response to zero and calibration or span gases over any 10 seconds period must not exceed 2 per cent of full scale on all ranges used.

3.1.4. Zero drift

The zero drift during a one hour period must be less than 2 per cent of full scale on the lowest range used. The zero response is defined as the mean response, including noise, to a zero gas during a 30 seconds time interval.

3.1.5. Span drift

The span drift during a one hour period must be less than 2 per cent of full scale on the lowest range used. Span is defined as the difference between the span response and the zero response. The span response is defined as the mean response, including noise, to a span gas during a 30 seconds time interval.

3.2. Gas drying

The optional gas drying device must have a minimal effect on the concentration of the measured gases. Chemical dryers are not an acceptable method of removing water from the sample.

3.3. Analysers

Paragraphs 3.3.1. to 3.3.4. describe the measurement principles to be used. A detailed description of the measurement systems is given in annex 4, appendix 7. The gases to be measured must be analysed with the following instruments. For non-linear analysers, the use of linearising circuits is permitted.

3.3.1. Carbon monoxide (CO) analysis

The carbon monoxide analyser must be of the Non-Dispersive Infra-Red (NDIR) absorption type.

3.3.2. Carbon dioxide (CO<sub>2</sub>) analysis

The carbon dioxide analyser must be of the Non-Dispersive Infra-Red (NDIR) absorption type.

### 3.3.3. Hydrocarbon (HC) analysis

For diesel and LPG fuelled gas engines, the hydrocarbon analyser must be of the Heated Flame Ionisation Detector (HFID) type with detector, valves, pipework, etc. heated so as to maintain a gas temperature of  $463\text{K} \pm 10\text{K}$  ( $190 \pm 10^\circ\text{C}$ ). For NG fuelled gas engines, the hydrocarbon analyser may be of the non heated Flame Ionisation Detector (FID) type depending upon the method used (see annex 4, appendix 7, paragraph 1.3.).

### 3.3.4. Non-methane hydrocarbon (NMHC) analysis (NG fuelled gas engines only)

Non-methane hydrocarbons must be determined by either of the following methods:

#### 3.3.4.1 Gas chromatographic (GC) method

Non-methane hydrocarbons must be determined by subtraction of the methane analysed with a Gas Chromatograph (GC) conditioned at 423 K ( $150^\circ\text{C}$ ) from the hydrocarbons measured according to paragraph 3.3.3.

#### 3.3.4.2. Non-methane cutter (NMC) method

The determination of the non-methane fraction must be performed with a heated NMC operated in line with an FID as per paragraph 3.3.3. by subtraction of the methane from the hydrocarbons.

### 3.3.5. Oxides of nitrogen ( $\text{NO}_x$ ) analysis

The oxides of nitrogen analyser must be of the Chemi-Luminescent Detector (CLD) or Heated Chemi-Luminescent Detector (HCLD) type with a  $\text{NO}_2/\text{NO}$  converter, if measured on a dry basis. If measured on a wet basis, a HCLD with converter maintained above 328 K ( $55^\circ\text{C}$ ) must be used, provided the water quench check (see annex 4, appendix 5, paragraph 1.9.2.2.) is satisfied.

## 3.4. Sampling of gaseous emissions

### 3.4.1. Raw exhaust gas (ESC only)

The gaseous emissions sampling probes must be fitted at least 0.5 m or 3 times the diameter of the exhaust pipe - whichever is the larger - upstream of the exit of the exhaust gas system as far as applicable and sufficiently close to the engine as to ensure an exhaust gas temperature of at least 343 K ( $70^\circ\text{C}$ ) at the probe.

In the case of a multi-cylinder engine with a branched exhaust manifold, the inlet of the probe must be located sufficiently far downstream so as to ensure that the sample is representative of the average exhaust emissions from all cylinders. In multi-cylinder engines having distinct groups of manifolds, such as in a "Vee" engine configuration, it is permissible to acquire a sample from each group individually and calculate an average exhaust emission. Other methods which have been shown to correlate with the above methods may

be used. For exhaust emission calculation the total exhaust mass flow must be used.

If the engine is equipped with an exhaust after-treatment system, the exhaust sample must be taken downstream of the exhaust after-treatment system.

#### 3.4.2. Diluted exhaust gas (mandatory for ETC, optional for ESC)

The exhaust pipe between the engine and the full flow dilution system must conform to the requirements of annex 4, appendix 7, paragraph 2.3.1., EP.

The gaseous emissions sample probe(s) must be installed in the dilution tunnel at a point where the dilution air and exhaust gas are well mixed, and in close proximity to the particulates sampling probe.

For the ETC, sampling can generally be done in two ways:

- the pollutants are sampled into a sampling bag over the cycle and measured after completion of the test;
- the pollutants are sampled continuously and integrated over the cycle; this method is mandatory for HC and NO<sub>x</sub>.

#### 4. DETERMINATION OF THE PARTICULATES

The determination of the particulates requires a dilution system. Dilution may be accomplished by a partial flow dilution system (ESC only) or a full flow dilution system (mandatory for ETC). The flow capacity of the dilution system must be large enough to completely eliminate water condensation in the dilution and sampling systems, and maintain the temperature of the diluted exhaust gas at or below 325K (52°C) immediately upstream of the filter holders. Dehumidifying the dilution air before entering the dilution system is permitted, and especially useful if dilution air humidity is high. The temperature of the dilution air must be 298 K ± 5 K (25°C ± 5°C). If the ambient temperature is below 293K (20°C), dilution air pre-heating above the upper temperature limit of 303K (30°C) is recommended. However, the dilution air temperature must not exceed 325 K (52°C) prior to the introduction of the exhaust in the dilution tunnel.

The partial flow dilution system has to be designed to split the exhaust stream into two fractions, the smaller one being diluted with air and subsequently used for particulate measurement. For this it is essential that the dilution ratio be determined very accurately. Different splitting methods can be applied, whereby the type of splitting used dictates to a significant degree the sampling hardware and procedures to be used (annex 4, appendix 7, paragraph 2.2.). The particulate sampling probe must be installed in close proximity to the gaseous emissions sampling probe, and the installation must comply with the provisions of paragraph 3.4.1.

To determine the mass of the particulates, a particulate sampling system, particulate sampling filters, a microgram balance, and a temperature and humidity controlled weighing chamber, are required. For particulate sampling, the single filter method must be applied which uses one pair of filters (see paragraph 4.1.3) for the whole test cycle. For the ESC, considerable attention must be paid to sampling times and flows during the sampling phase of the test.

#### 4.1. Particulate sampling filters

##### 4.1.1. Filter specification

Fluorocarbon coated glass fibre filters or fluorocarbon based membrane filters are required. All filter types must have a 0.3 µm DOP (di-octylphthalate) collection efficiency of at least 95 per cent at a gas face velocity between 35 and 80 cm/s.

##### 4.1.2. Filter size

Particulate filters must have a minimum diameter of 47 mm (37 mm stain diameter). Larger diameter filters are acceptable (paragraph 4.1.5).

##### 4.1.3. Primary and back-up Filters

The diluted exhaust must be sampled by a pair of filters placed in series (one primary and one back-up filter) during the test sequence. The back-up filter must be located no more than 100 mm downstream of, and must not be in contact with the primary filter. The filters may be weighed separately or as a pair with the filters placed stain side to stain side.

##### 4.1.4. Filter face velocity

A gas face velocity through the filter of 35 to 80 cm/s must be achieved. The pressure drop increase between the beginning and the end of the test must be no more than 25 kPa.

##### 4.1.5. Filter loading

The recommended minimum filter loading must be 0.5 mg/1075 mm<sup>2</sup> stain area. For the most common filter sizes the values are shown in table 9.

Table 9: Recommended filter loadings

Filter Diameter (mm)	Recommended Stain	Recommended Minimum
47	37	0.5
70	60	1.3
90	80	2.3
110	100	3.6

4.2. Weighing chamber and analytical balance specifications

4.2.1. Weighing chamber conditions

The temperature of the chamber (or room) in which the particulate filters are conditioned and weighed must be maintained to within  $295\text{K} \pm 3\text{ K}$  ( $22^\circ\text{C} \pm 3^\circ\text{C}$ ) during all filter conditioning and weighing. The humidity must be maintained to a dew point of  $282.5\text{K} \pm 3\text{ K}$  ( $9.5^\circ\text{C} \pm 3^\circ\text{C}$ ) and a relative humidity of  $45\% \pm 8\%$ .

4.2.2. Reference filter weighing

The chamber (or room) environment must be free of any ambient contaminants (such as dust) that would settle on the particulate filters during their stabilisation. Disturbances to weighing room specifications as outlined in paragraph 4.2.1. will be allowed if the duration of the disturbances does not exceed 30 minutes. The weighing room should meet the required specifications prior to personal entrance into the weighing room. At least two unused reference filters or reference filter pairs must be weighed within 4 hours of, but preferably at the same time as the sample filter (pair) weighings. They must be the same size and material as the sample filters.

If the average weight of the reference filters (reference filter pairs) changes between sample filter weighings by more than  $\pm 5$  per cent ( $\pm 7.5$  per cent for the filter pair respectively) of the recommended minimum filter loading (paragraph 4.1.5.), then all sample filters must be discarded and the emissions test repeated.

If the weighing room stability criteria outlined in paragraph 4.2.1. is not met, but the reference filter (pair) weighings meet the above criteria, the engine manufacturer has the option of accepting the sample filter weights or voiding the tests, fixing the weighing room control system and rerunning the test.

4.2.3. Analytical balance

The analytical balance used to determine the weights of all filters must have a precision (standard deviation) of  $20\ \mu\text{g}$  and a resolution of  $10\ \mu\text{g}$  (1 digit =  $10\ \mu\text{g}$ ). For filters less than 70 mm diameter, the precision and resolution must be  $2\ \mu\text{g}$  and  $1\ \mu\text{g}$ , respectively.

4.2.4. Elimination of static electricity effects

To eliminate the effects of static electricity, the filters should be neutralised prior to weighing, e.g. by a Polonium neutraliser or a device of similar effect.

4.3. Additional specifications for particulate measurement

All parts of the dilution system and the sampling system from the exhaust pipe up to the filter holder, which are in contact with raw and diluted exhaust gas, must be designed to minimise deposition or alteration of the particulates. All parts must be made of electrically conductive materials that do not react with exhaust gas



components, and must be electrically grounded to prevent electrostatic effects.

## 5. DETERMINATION OF SMOKE OPACITY

This paragraph provides specifications for the required and optional test equipment to be used for the ELR test. The smoke must be measured with an opacimeter having an opacity and a light absorption coefficient readout mode. The opacity readout mode must only be used for calibration and checking of the opacimeter. The smoke values of the test cycle must be measured in the light absorption coefficient readout mode.

### 5.1. General requirements

The ELR requires the use of a smoke measurement and data processing system which includes three functional units. These units may be integrated into a single component or provided as a system of interconnected components. The three functional units are:

- An opacimeter meeting the specifications of annex 4, appendix 7, paragraph 3.
- A data processing unit capable of performing the functions described in annex 4, appendix 1, paragraph 6.
- A printer and/or electronic storage medium to record and output the required smoke values specified in annex 4, appendix 1, paragraph 6.3.

### 5.2. Specific requirements

#### 5.2.1. Linearity

The linearity must be within  $\pm 2$  per cent opacity.

#### 5.2.2. Zero drift

The zero drift during a one hour period must not exceed  $\pm 1$  per cent opacity.

#### 5.2.3. Opacimeter display and range

For display in opacity, the range must be 0 - 100 per cent opacity, and the readability 0.1 per cent opacity. For display in light absorption coefficient, the range must be 0 - 30  $\text{m}^{-1}$  light absorption coefficient, and the readability 0.01  $\text{m}^{-1}$  light absorption coefficient.

#### 5.2.4. Instrument response time

The physical response time of the opacimeter must not exceed 0.2 s. The physical response time is the difference between the times when the output of a rapid response receiver reaches 10 and 90 per cent of

the full deviation when the opacity of the gas being measured is changed in less than 0.1 s.

The electrical response time of the opacimeter must not exceed 0.05 s. The electrical response time is the difference between the times when the opacimeter output reaches 10 and 90 per cent of the full scale when the light source is interrupted or completely extinguished in less than 0.01 s.

#### 5.2.5. Neutral density filters

Any neutral density filter used in conjunction with opacimeter calibration, linearity measurements, or setting span must have its value known to within 1.0 per cent opacity. The filter's nominal value must be checked for accuracy at least yearly using a reference traceable to a national or international standard.

Neutral density filters are precision devices and can easily be damaged during use. Handling should be minimised and, when required, should be done with care to avoid scratching or soiling of the filter.

\_\_\_\_\_ "

Insert new Annex 4 - Appendix 5, to read:

### "Annex 4 - Appendix 5

#### CALIBRATION PROCEDURE

#### 1. CALIBRATION OF THE ANALYTICAL INSTRUMENTS

##### 1.1. Introduction

Each analyser must be calibrated as often as necessary to fulfil the accuracy requirements of this Regulation. The calibration method that must be used is described in this paragraph for the analysers indicated in annex 4, appendix 4, paragraph 3. and annex 4, appendix 7, paragraph 1.

##### 1.2. Calibration gases

The shelf life of all calibration gases must be respected. The expiration date of the calibration gases stated by the manufacturer must be recorded.

##### 1.2.1. Pure gases

The required purity of the gases is defined by the contamination limits given below. The following gases must be available for operation:

Purified nitrogen  
(Contamination 1 ppm Cl, 1 ppm CO, 400 ppm CO<sub>2</sub>, 0.1 ppm NO)

Purified oxygen  
(Purity  $\geq$  99.5 % vol O<sub>2</sub>)

Hydrogen-helium mixture  
(40  $\pm$  2 % hydrogen, balance helium)  
(Contamination 1 ppm Cl, 400 ppm CO<sub>2</sub>)

Purified synthetic air  
(Contamination 1 ppm Cl, 1 ppm CO, 400 ppm CO<sub>2</sub>, 0.1 ppm NO)  
(Oxygen content between 18-21 % vol.)

Purified propane or CO for the CVS verification

#### 1.2.2. Calibration and span gases

Mixtures of gases having the following chemical compositions must be available:

C<sub>3</sub>H<sub>8</sub> and purified synthetic air (see paragraph 1.2.1);

CO and purified nitrogen;

NO<sub>x</sub> and purified nitrogen (the amount of NO<sub>2</sub> contained in this calibration gas must not exceed 5 % of the NO content);

CO<sub>2</sub> and purified nitrogen

CH<sub>4</sub> and purified synthetic air

C<sub>2</sub>H<sub>6</sub> and purified synthetic air

Note: Other gas combinations are allowed provided the gases do not react with one another.

The true concentration of a calibration and span gas must be within  $\pm$  2 per cent of the nominal value. All concentrations of calibration gas must be given on a volume basis (volume percent or volume ppm). The gases used for calibration and span may also be obtained by means of a gas divider, diluting with purified N<sub>2</sub> or with purified synthetic air. The accuracy of the mixing device must be such that the concentration of the diluted calibration gases may be determined to within  $\pm$  2 per cent.

#### 1.3. Operating procedure for analysers and sampling system

The operating procedure for analysers must follow the start-up and operating instructions of the instrument manufacturer. The minimum requirements given in paragraphs 1.4. to 1.9. must be included.

1.4. Leakage test

A system leakage test must be performed. The probe must be disconnected from the exhaust system and the end plugged. The analyser pump must be switched on. After an initial stabilisation period all flow meters should read zero. If not, the sampling lines must be checked and the fault corrected.

The maximum allowable leakage rate on the vacuum side must be 0.5 per cent of the in-use flow rate for the portion of the system being checked. The analyser flows and bypass flows may be used to estimate the in-use flow rates.

Another method is the introduction of a concentration step change at the beginning of the sampling line by switching from zero to span gas. If after an adequate period of time the reading shows a lower concentration compared to the introduced concentration, this points to calibration or leakage problems.

1.5. Calibration procedure

1.5.1. Instrument assembly

The instrument assembly must be calibrated and calibration curves checked against standard gases. The same gas flow rates must be used as when sampling exhaust.

1.5.2. Warming-up time

The warming-up time should be according to the recommendations of the manufacturer. If not specified, a minimum of two hours is recommended for warming up the analysers.

1.5.3. NDIR and HFID analyser

The NDIR analyser must be tuned, as necessary, and the combustion flame of the HFID analyser must be optimised (paragraph 1.8.1).

1.5.4. Calibration

Each normally used operating range must be calibrated.

Using purified synthetic air (or nitrogen), the CO, CO<sub>2</sub>, NO<sub>x</sub> and HC analysers must be set at zero.

The appropriate calibration gases must be introduced to the analysers, the values recorded, and the calibration curve established according to paragraph 1.5.5.

The zero setting must be rechecked and the calibration procedure repeated, if necessary.

1.5.5. Establishment of the calibration curve

1.5.5.1. General guidelines

The analyser calibration curve must be established by at least five calibration points (excluding zero) spaced as uniformly as possible. The highest nominal concentration must be equal to or higher than 90 per cent of full scale.

The calibration curve must be calculated by the method of least squares. If the resulting polynomial degree is greater than 3, the number of calibration points (zero included) must be at least equal to this polynomial degree plus 2.

The calibration curve must not differ by more than  $\pm 2$  per cent from the nominal value of each calibration point and by more than  $\pm 1$  per cent of full scale at zero.

From the calibration curve and the calibration points, it is possible to verify that the calibration has been carried out correctly. The different characteristic parameters of the analyser must be indicated, particularly:

- the measuring range;
- the sensitivity;
- the date of carrying out the calibration.

1.5.5.2. Calibration below 15 per cent of Full Scale

The analyser calibration curve must be established by at least 4 additional calibration points (excluding zero) spaced nominally equally below 15 per cent of full scale.

The calibration curve is calculated by the method of least squares.

The calibration curve must not differ by more than  $\pm 4$  per cent from the nominal value of each calibration point and by more than  $\pm 1$  per cent of full scale at zero.

1.5.5.3. Alternative methods

If it can be shown that alternative technology (e.g. computer, electronically controlled range switch, etc.) can give equivalent accuracy, then these alternatives may be used.

1.6. Verification of the calibration

Each normally used operating range must be checked prior to each analysis in accordance with the following procedure.

The calibration must be checked by using a zero gas and a span gas whose nominal value is more than 80 per cent of full scale of the measuring range.

If, for the two points considered, the value found does not differ by more than  $\pm 4$  per cent of full scale from the declared reference

value, the adjustment parameters may be modified. Should this not be the case, a new calibration curve must be established in accordance with paragraph 1.5.5.

### 1.7. Efficiency test of the NO<sub>x</sub> converter

The efficiency of the converter used for the conversion of NO<sub>2</sub> into NO must be tested as given in paragraphs 1.7.1. to 1.7.8. (Figure 6).

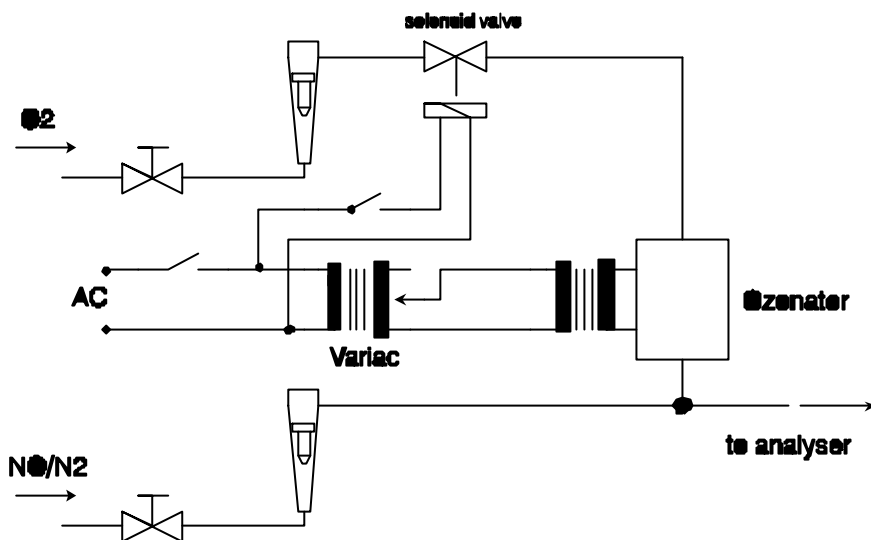

Figure 6 Schematic of NO<sub>2</sub> converter efficiency device

#### 1.7.1. Test set-up

Using the test set-up as shown in Figure 6 (see also annex 4, appendix 4, paragraph 3.3.5.) and the procedure below, the efficiency of converters can be tested by means of an ozonator.

#### 1.7.2. Calibration

The CLD and the HCLD must be calibrated in the most common operating range following the manufacturer's specifications using zero and span gas (the NO content of which must amount to about 80 per cent of the operating range and the NO<sub>2</sub> concentration of the gas mixture to less than 5 per cent of the NO concentration). The NO<sub>x</sub> analyser must be in the NO mode so that the span gas does not pass through the converter. The indicated concentration has to be recorded.

#### 1.7.3. Calculation

The efficiency of the NO<sub>x</sub> converter is calculated as follows:

$$Efficiency(\%) = \left(1 + \frac{a - b}{c - d}\right) * 100$$

where:

- a is the NO<sub>x</sub> concentration according to paragraph 1.7.6
- b is the NO<sub>x</sub> concentration according to paragraph 1.7.7
- c is the NO concentration according to paragraph 1.7.4
- d is the NO concentration according to paragraph 1.7.5

1.7.4. Adding of oxygen

Via a T-fitting, oxygen or zero air is added continuously to the gas flow until the concentration indicated is about 20 per cent less than the indicated calibration concentration given in paragraph 1.7.2. (The analyser is in the NO mode). The indicated concentration c must be recorded. The ozonator is kept deactivated throughout the process.

1.7.5. Activation of the ozonator

The ozonator is now activated to generate enough ozone to bring the NO concentration down to about 20 per cent (minimum 10 per cent) of the calibration concentration given in paragraph 1.7.2. The indicated concentration d must be recorded (The analyser is in the NO mode).

1.7.6. NO<sub>x</sub> mode

The NO analyser is then switched to the NO<sub>x</sub> mode so that the gas mixture (consisting of NO, NO<sub>2</sub>, O<sub>2</sub> and N<sub>2</sub>) now passes through the converter. The indicated concentration a must be recorded. (The analyser is in the NO<sub>x</sub> mode).

1.7.7. Deactivation of the ozonator

The ozonator is now deactivated. The mixture of gases described in paragraph 1.7.6. passes through the converter into the detector. The indicated concentration b must be recorded. (The analyser is in the NO<sub>x</sub> mode).

1.7.8. NO mode

Switched to NO mode with the ozonator deactivated, the flow of oxygen or synthetic air is also shut off. The NO<sub>x</sub> reading of the analyser must not deviate by more than ± 5 per cent from the value measured according to paragraph 1.7.2. (The analyser is in the NO mode).

1.7.9. Test interval

The efficiency of the converter must be tested prior to each calibration of the NO<sub>x</sub> analyser.

1.7.10. Efficiency requirement

The efficiency of the converter must not be less than 90 per cent, but a higher efficiency of 95 per cent is strongly recommended.

Note: If, with the analyser in the most common range, the ozonator cannot give a reduction from 80 per cent to 20 per cent according to paragraph 1.7.5., then the highest range which will give the reduction must be used.

## 1.8. Adjustment of the FID

### 1.8.1. Optimisation of the detector response

The FID must be adjusted as specified by the instrument manufacturer. A propane in air span gas should be used to optimise the response on the most common operating range.

With the fuel and air flow rates set at the manufacturer's recommendations, a  $350 \pm 75$  ppm C span gas must be introduced to the analyser. The response at a given fuel flow must be determined from the difference between the span gas response and the zero gas response. The fuel flow must be incrementally adjusted above and below the manufacturer's specification. The span and zero response at these fuel flows must be recorded. The difference between the span and zero response must be plotted and the fuel flow adjusted to the rich side of the curve.

### 1.8.2. Hydrocarbon response factors

The analyser must be calibrated using propane in air and purified synthetic air, according to paragraph 1.5.

Response factors must be determined when introducing an analyser into service and after major service intervals. The response factor ( $R_f$ ) for a particular hydrocarbon species is the ratio of the FID C1 reading to the gas concentration in the cylinder expressed by ppm C1.

The concentration of the test gas must be at a level to give a response of approximately 80 per cent of full scale. The concentration must be known to an accuracy of  $\pm 2$  per cent in reference to a gravimetric standard expressed in volume. In addition, the gas cylinder must be preconditioned for 24 hours at a temperature of  $298 \text{ K} \pm 5 \text{ K}$  ( $25^\circ\text{C} \pm 5^\circ\text{C}$ ).

The test gases to be used and the recommended relative response factor ranges are as follows:

Methane and purified synthetic air	1.00	$R_f$	1.15
Propylene and purified synthetic air	0.90	$R_f$	1.1
Toluene and purified synthetic air	0.90	$R_f$	1.10

These values are relative to the response factor ( $R_f$ ) of 1.00 for propane and purified synthetic air.

### 1.8.3. Oxygen interference check

The oxygen interference check must be determined when introducing an analyser into service and after major service intervals.



The response factor is defined and must be determined as described in paragraph 1.8.2. The test gas to be used and the recommended relative response factor range are as follows:

Propane and nitrogen                      0.95     $R_f$     1.05

This value is relative to the response factor ( $R_f$ ) of 1.00 for propane and purified synthetic air.

The FID burner air oxygen concentration must be within  $\pm 1$  mole % of the oxygen concentration of the burner air used in the latest oxygen interference check. If the difference is greater, the oxygen interference must be checked and the analyser adjusted, if necessary.

#### 1.8.4. Efficiency of the non-methane cutter (NMC, for NG fuelled gas engines only)

The NMC is used for the removal of the non-methane hydrocarbons from the sample gas by oxidising all hydrocarbons except methane. Ideally, the conversion for methane is 0 %, and for the other hydrocarbons represented by ethane is 100 %. For the accurate measurement of NMHC, the two efficiencies must be determined and used for the calculation of the NMHC emission mass flow rate (see annex 4, appendix 2, paragraph 4.3.).

##### 1.8.4.1. Methane efficiency

Methane calibration gas must be flown through the FID with and without bypassing the NMC and the two concentrations recorded. The efficiency must be determined as follows:

$$C E_M = 1 - \frac{c o n c_w}{c o n c_{w/o}}$$

where:

$conc_w$  = HC concentration with  $CH_4$  flowing through the NMC

$conc_{w/o}$  = HC concentration with  $CH_4$  bypassing the NMC

##### 1.8.4.2. Ethane efficiency

Ethane calibration gas must be flown through the FID with and without bypassing the NMC and the two concentrations recorded. The efficiency must be determined as follows:

$$C E_E = 1 - \frac{c o n c_w}{c o n c_{w/o}}$$

where:

$conc_w$  = HC concentration with  $C_2H_6$  flowing through the NMC

$conc_{w/o}$  = HC concentration with  $C_2H_6$  bypassing the NMC

1.9. Interference effects with CO, CO<sub>2</sub>, and NO<sub>x</sub> analysers

Gases present in the exhaust other than the one being analysed can interfere with the reading in several ways. Positive interference occurs in NDIR instruments where the interfering gas gives the same effect as the gas being measured, but to a lesser degree. Negative interference occurs in NDIR instruments by the interfering gas broadening the absorption band of the measured gas, and in CLD instruments by the interfering gas quenching the radiation. The interference checks in paragraphs 1.9.1. and 1.9.2. must be performed prior to an analyser's initial use and after major service intervals.

1.9.1. CO Analyser interference check

Water and CO<sub>2</sub> can interfere with the CO analyser performance. Therefore, a CO<sub>2</sub> span gas having a concentration of 80 to 100 per cent of full scale of the maximum operating range used during testing must be bubbled through water at room temperature and the analyser response recorded. The analyser response must not be more than 1 per cent of full scale for ranges equal to or above 300 ppm or more than 3 ppm for ranges below 300 ppm.

1.9.2. NO<sub>x</sub> analyser quench checks

The two gases of concern for CLD (and HCLD) analysers are CO<sub>2</sub> and water vapour. Quench responses to these gases are proportional to their concentrations, and therefore require test techniques to determine the quench at the highest expected concentrations experienced during testing.

1.9.2.1. CO<sub>2</sub> quench check

A CO<sub>2</sub> span gas having a concentration of 80 to 100 per cent of full scale of the maximum operating range must be passed through the NDIR analyser and the CO<sub>2</sub> value recorded as A. It must then be diluted approximately 50 per cent with NO span gas and passed through the NDIR and (H)CLD, with the CO<sub>2</sub> and NO values recorded as B and C, respectively. The CO<sub>2</sub> must then be shut off and only the NO span gas be passed through the (H)CLD and the NO value recorded as D.

The quench, which must not be greater than 3 per cent of full scale, must be calculated as follows:

$$\% \text{ Quench} = \left[ 1 - \left( \frac{(C * A)}{(D * A) - (D * B)} \right) \right] * 100$$

where:

A is the undiluted CO<sub>2</sub> concentration measured with NDIR in per cent  
B is the diluted CO<sub>2</sub> concentration measured with NDIR in per cent  
C is the diluted NO concentration measured with (H)CLD in ppm  
D is the undiluted NO concentration measured with (H)CLD in ppm

Alternative methods of diluting and quantifying of CO<sub>2</sub> and NO span gas values such as dynamic mixing/blending can be used.

#### 1.9.2.2. Water quench check

This check applies to wet gas concentration measurements only. Calculation of water quench must consider dilution of the NO span gas with water vapour and scaling of water vapour concentration of the mixture to that expected during testing.

A NO span gas having a concentration of 80 to 100 per cent of full scale of the normal operating range must be passed through the (H)CLD and the NO value recorded as D. The NO span gas must then be bubbled through water at room temperature and passed through the (H)CLD and the NO value recorded as C. The analyser's absolute operating pressure and the water temperature must be determined and recorded as E and F, respectively. The mixture's saturation vapour pressure that corresponds to the bubbler water temperature F must be determined and recorded as G. The water vapour concentration (H, in %) of the mixture must be calculated as follows:

$$H = 100 * ( G/E )$$

The expected diluted NO span gas (in water vapour) concentration (De) must be calculated as follows:

$$De = D * ( 1 - H/100 )$$

For diesel exhaust, the maximum exhaust water vapour concentration (Hm, in %) expected during testing must be estimated, under the assumption of a fuel atom H/C ratio of 1.8:1. from the undiluted CO<sub>2</sub> span gas concentration (A, as measured in paragraph 1.9.2.1) as follows:

$$Hm = 0.9 * A$$

The water quench, which must not be greater than 3 per cent, must be calculated as follows:

$$\% \text{ Quench} = 100 * ( ( De - C ) / De ) * ( Hm / H )$$

where:

De is the expected diluted NO concentration in ppm

C is the diluted NO concentration in ppm

Hm is the maximum water vapour concentration in %

H is the actual water vapour concentration in %

Note: It is important that the NO span gas contains minimal NO<sub>2</sub> concentration for this check, since absorption of NO<sub>2</sub> in water has not been accounted for in the quench calculations.

1.10. Calibration intervals

The analysers must be calibrated according to paragraph 1.5. at least every 3 months or whenever a system repair or change is made that could influence calibration.

2. CALIBRATION OF THE CVS-SYSTEM

2.1. General

The CVS system must be calibrated by using an accurate flowmeter traceable to national or international standards and a restricting device. The flow through the system must be measured at different restriction settings, and the control parameters of the system must be measured and related to the flow.

Various types of flowmeters may be used, e. g. calibrated venturi, calibrated laminar flowmeter, calibrated turbinometer.

2.2. Calibration of the positive displacement pump (PDP)

All parameters related to the pump must be simultaneously measured with the parameters related to the flowmeter which is connected in series with the pump. The calculated flow rate (in m<sup>3</sup>/min at pump inlet, absolute pressure and temperature) must be plotted versus a correlation function which is the value of a specific combination of pump parameters. The linear equation which relates the pump flow and the correlation function must then be determined. If a CVS has a multiple speed drive, the calibration must be performed for each range used. Temperature stability must be maintained during calibration.

2.2.1. Data analysis

The air flow rate ( $Q_s$ ) at each restriction setting (minimum 6 settings) must be calculated in standard m<sup>3</sup>/min from the flowmeter data using the manufacturer's prescribed method. The air flow rate must then be converted to pump flow ( $V_0$ ) in m<sup>3</sup>/rev at absolute pump inlet temperature and pressure as follows:

$$V_0 = \frac{Q_s}{n} * \frac{T}{273} * \frac{101,3}{P_A}$$

where:

$Q_s$  = air flow rate at standard conditions (101.3 kPa, 273 K), m<sup>3</sup>/s

$T$  = temperature at pump inlet, K

$P_A$  = absolute pressure at pump inlet ( $p_B - p_1$ ), kPa

$n$  = pump speed, rev/s

To account for the interaction of pressure variations at the pump and the pump slip rate, the correlation function ( $X_0$ ) between pump speed, pressure differential from pump inlet to pump outlet and absolute pump outlet pressure must be calculated as follows:

$$X_0 = \frac{1}{n} * \sqrt{\frac{\Delta r_A}{r_A}}$$

where:

$\Delta p_P$  = pressure differential from pump inlet to pump outlet, kPa

$p_A$  = absolute outlet pressure at pump outlet, kPa

A linear least-square fit must be performed to generate the calibration equation as follows:

$$V_0 = D_0 - m * (X_0)$$

$D_0$  and  $m$  are the intercept and slope constants, respectively, describing the regression lines.

For a CVS system with multiple speeds, the calibration curves generated for the different pump flow ranges must be approximately parallel, and the intercept values ( $D_0$ ) must increase as the pump flow range decreases.

The calculated values from the equation must be within  $\pm 0.5$  per cent of the measured value of  $V_0$ . Values of  $m$  will vary from one pump to another. Particulate influx over time will cause the pump slip to decrease, as reflected by lower values for  $m$ . Therefore, calibration must be performed at pump start-up, after major maintenance, and if the total system verification (paragraph 2.4) indicates a change of the slip rate.

### 2.3. Calibration of the critical flow venturi (CFV)

Calibration of the CFV is based upon the flow equation for a critical venturi. Gas flow is a function of inlet pressure and temperature, as shown below:

$$Q_s = \frac{K_v r_A}{\sqrt{T}}$$

where:

$K_v$  = calibration coefficient

$p_A$  = absolute pressure at venturi inlet, kPa

$T$  = temperature at venturi inlet, K

#### 2.3.1. Data Analysis

The air flow rate ( $Q_s$ ) at each restriction setting (minimum 8 settings) must be calculated in standard  $m^3/min$  from the flowmeter data using the manufacturer's prescribed method. The calibration coefficient must be calculated from the calibration data for each setting as follows:

$$K_v = \frac{Q_s * \sqrt{T}}{r_A}$$

where:

$Q_s$  = air flow rate at standard conditions (101.3 kPa, 273 K), m<sup>3</sup>/s  
 $T$  = temperature at the venturi inlet, K  
 $p_A$  = absolute pressure at venturi inlet, kPa

To determine the range of critical flow,  $K_v$  must be plotted as a function of venturi inlet pressure. For critical (choked) flow,  $K_v$  will have a relatively constant value. As pressure decreases (vacuum increases), the venturi becomes unchoked and  $K_v$  decreases, which indicates that the CFV is operated outside the permissible range.

For a minimum of eight points in the region of critical flow, the average  $K_v$  and the standard deviation must be calculated. The standard deviation must not exceed  $\pm 0.3$  per cent of the average  $K_v$ .

#### 2.4. Total system verification

The total accuracy of the CVS sampling system and analytical system must be determined by introducing a known mass of a pollutant gas into the system while it is being operated in the normal manner. The pollutant is analysed, and the mass calculated according to annex 4, appendix 2, paragraph 4.3., except in the case of propane where a factor of 0.000472 is used in place of 0.000479 for HC. Either of the following two techniques must be used.

##### 2.4.1. Metering with a critical flow orifice

A known quantity of pure gas (carbon monoxide or propane) must be fed into the CVS system through a calibrated critical orifice. If the inlet pressure is high enough, the flow rate, which is adjusted by means of the critical flow orifice, is independent of the orifice outlet pressure (critical flow). The CVS system must be operated as in a normal exhaust emission test for about 5 to 10 minutes. A gas sample must be analysed with the usual equipment (sampling bag or integrating method), and the mass of the gas calculated. The mass so determined must be within  $\pm 3$  per cent of the known mass of the gas injected.

##### 2.4.2. Metering by means of a gravimetric technique

The weight of a small cylinder filled with carbon monoxide or propane must be determined with a precision of  $\pm 0.01$  gram. For about 5 to 10 minutes, the CVS system must be operated as in a normal exhaust emission test, while carbon monoxide or propane is injected into the system. The quantity of pure gas discharged must be determined by means of differential weighing. A gas sample must be analysed with the usual equipment (sampling bag or integrating method), and the mass of the gas calculated. The mass so determined must be within  $\pm 3$  per cent of the known mass of the gas injected.

### 3. CALIBRATION OF THE PARTICULATE MEASURING SYSTEM

#### 3.1. Introduction

Each component must be calibrated as often as necessary to fulfil the accuracy requirements of this Regulation. The calibration method to be used is described in this paragraph for the components indicated in annex 4, appendix 4, paragraph 4. and annex 4, appendix 7, paragraph 2.

#### 3.2. Flow measurement

The calibration of gas flow meters or flow measurement instrumentation must be traceable to international and/or national standards. The maximum error of the measured value must be within  $\pm 2$  per cent of reading.

If the gas flow is determined by differential flow measurement, the maximum error of the difference must be such that the accuracy of  $G_{EDF}$  is within  $\pm 4$  per cent (see also annex 4, appendix 7, paragraph 2.2.1., EGA). It can be calculated by taking the Root-Mean-Square of the errors of each instrument.

#### 3.3. Checking the partial flow conditions

The range of the exhaust gas velocity and the pressure oscillations must be checked and adjusted according to the requirements of annex 4, appendix 7, paragraph 2.2.1., EP, if applicable.

#### 3.4. Calibration intervals

The flow measurement instrumentation must be calibrated at least every 3 months or whenever a system repair or change is made that could influence calibration.

### 4. CALIBRATION OF THE SMOKE MEASUREMENT EQUIPMENT

#### 4.1. Introduction

The opacimeter must be calibrated as often as necessary to fulfil the accuracy requirements of this Regulation. The calibration method to be used is described in this paragraph for the components indicated in annex 4, appendix 4, paragraph 5. and annex 4, appendix 7, paragraph 3.

#### 4.2. Calibration procedure

##### 4.2.1. Warming-up time

The opacimeter must be warmed up and stabilised according to the manufacturer's recommendations. If the opacimeter is equipped with a purge air system to prevent sooting of the instrument optics, this system should also be activated and adjusted according to the manufacturer's recommendations.

4.2.2. Establishment of the linearity response

The linearity of the opacimeter must be checked in the opacity readout mode as per the manufacturer's recommendations. Three neutral density filters of known transmittance, which must meet the requirements of annex 4, appendix 4, paragraph 5.2.5., must be introduced to the opacimeter and the value recorded. The neutral density filters must have nominal opacities of approximately 10 %, 20 % and 40 %.

The linearity must not differ by more than  $\pm 2$  per cent opacity from the nominal value of the neutral density filter. Any non-linearity exceeding the above value must be corrected prior to the test.

4.3. Calibration intervals

The opacimeter must be calibrated according to paragraph 4.2.2. at least every 3 months or whenever a system repair or change is made that could influence calibration.

\_\_\_\_\_ "

Insert new Annex 4 - Appendix 6, to read:

"Annex 4 - Appendix 6

ANALYTICAL AND SAMPLING SYSTEMS

1. DETERMINATION OF THE GASEOUS EMISSIONS

1.1. Introduction

Paragraph 1.2. and figures 7 and 8 contain detailed descriptions of the recommended sampling and analysing systems. Since various configurations can produce equivalent results, exact conformance with figures 7 and 8 is not required. Additional components such as instruments, valves, solenoids, pumps, and switches may be used to provide additional information and coordinate the functions of the component systems. Other components which are not needed to maintain the accuracy on some systems, may be excluded if their exclusion is based upon good engineering judgement.



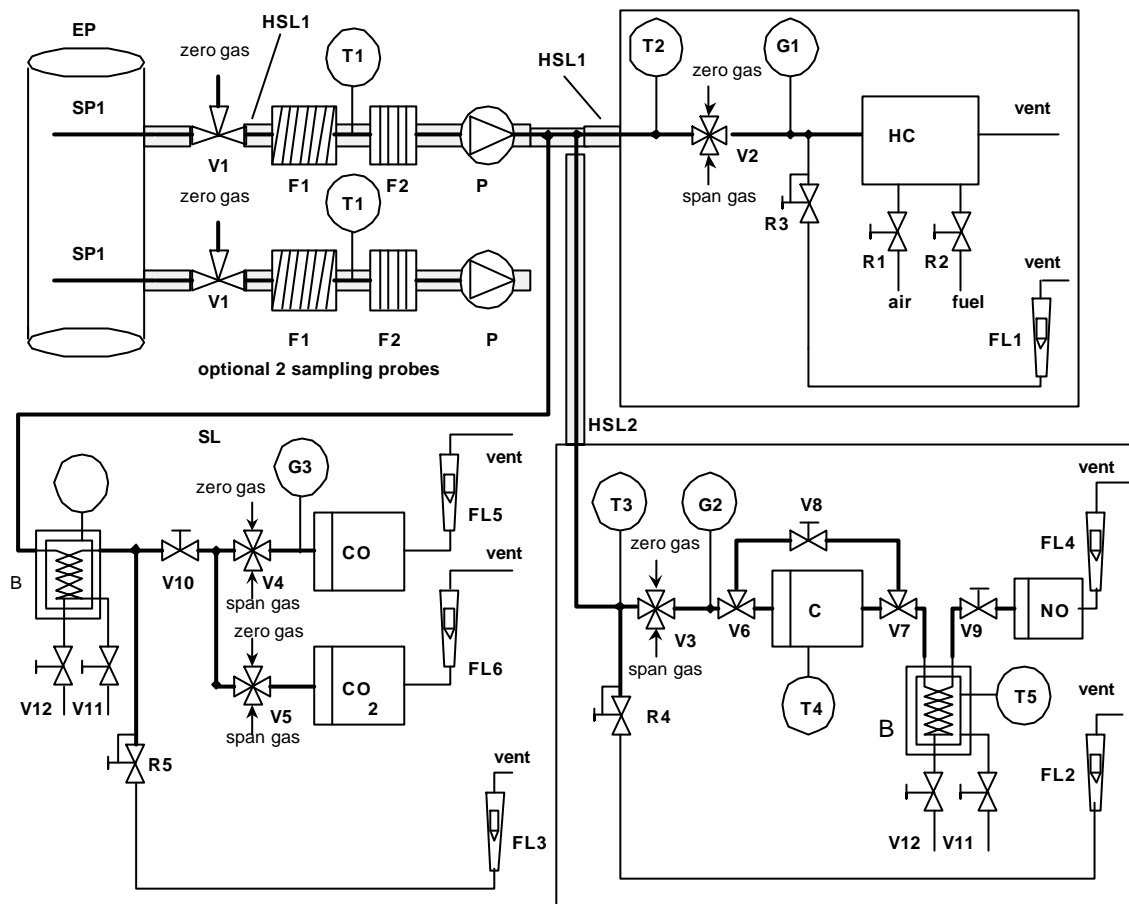

Figure 7 - Flow diagram of raw exhaust gas analysis system for CO, CO<sub>2</sub>, NO<sub>x</sub>, HC ESC only

### 1.2. Description of the analytical system

An analytical system for the determination of the gaseous emissions in the raw (Figure 7, ESC only) or diluted (Figure 8, ETC and ESC) exhaust gas is described based on the use of:

- HFID analyser for the measurement of hydrocarbons;
- NDIR analysers for the measurement of carbon monoxide and carbon dioxide;
- HCLD or equivalent analyser for the measurement of the oxides of nitrogen;

The sample for all components may be taken with one sampling probe or with two sampling probes located in close proximity and internally split to the different analysers. Care must be taken that no condensation of exhaust components (including water and sulphuric acid) occurs at any point of the analytical system.

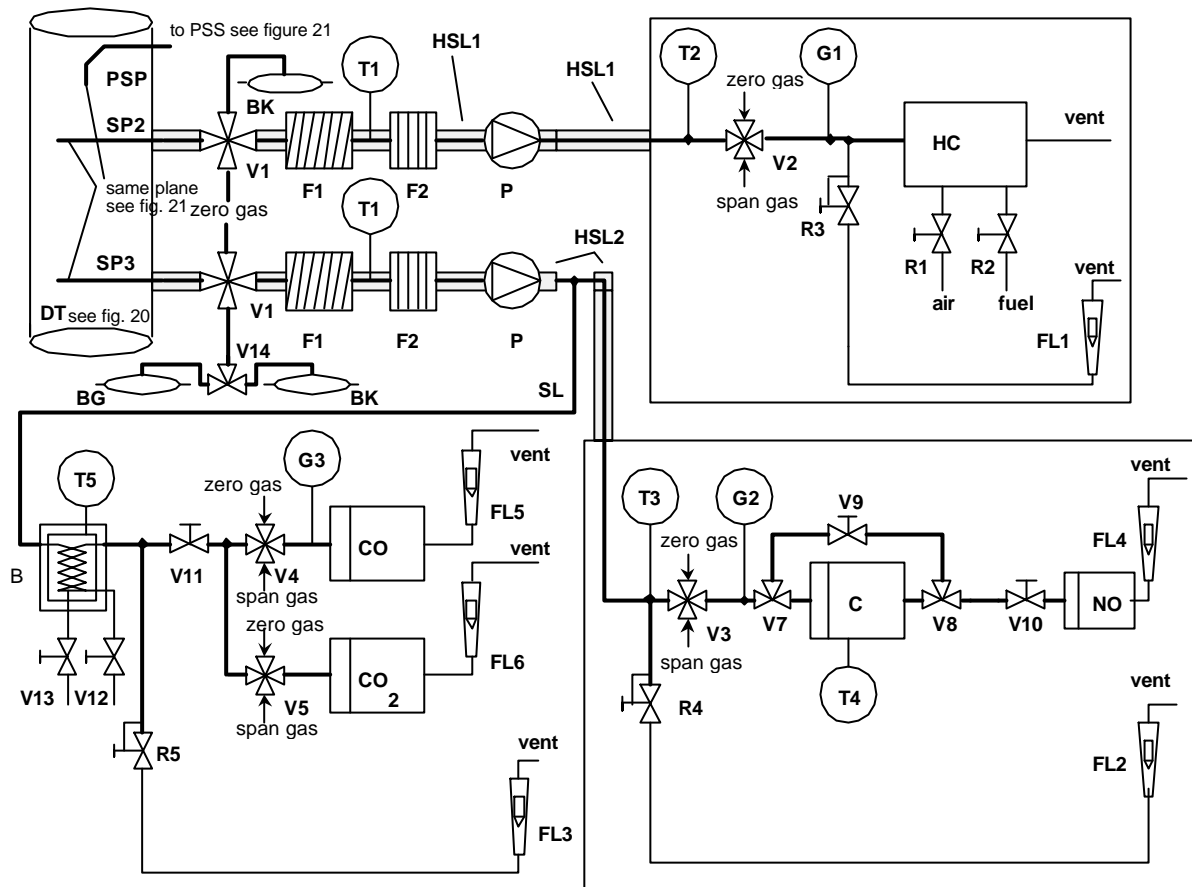

**Figure 8** - Flow diagram of diluted exhaust gas analysis system for CO, CO<sub>2</sub>, NO<sub>x</sub>, HC (ETC, optional for Economic and Social Committee)

1.2.1.1. Components of figures 7 and 8

**EP** Exhaust pipe

**SP1** Exhaust gas sampling probe (Figure 7 only)

A stainless steel straight closed end multi-hole probe is recommended. The inside diameter must not be greater than the inside diameter of the sampling line. The wall thickness of the probe must not be greater than 1 mm. There must be a minimum of 3 holes in 3 different radial planes sized to sample approximately the same flow. The probe must extend across at least 80 per cent of the diameter of the exhaust pipe. One or two sampling probes may be used.

**SP2** Diluted exhaust gas HC sampling probe (Figure 8 only)

The probe must:

- be defined as the first 254 mm to 762 mm of the heated sampling line HSL1;

- have a 5 mm minimum inside diameter;
- be installed in the dilution tunnel DT (see paragraph 2.3., Figure 20) at a point where the dilution air and exhaust gas are well mixed (i.e. approximately 10 tunnel diameters downstream of the point where the exhaust enters the dilution tunnel);
- be sufficiently distant (radially) from other probes and the tunnel wall so as to be free from the influence of any wakes or eddies;
- be heated so as to increase the gas stream temperature to  $463\text{ K} \pm 10\text{ K}$  ( $190^{\circ}\text{C} \pm 10^{\circ}\text{C}$ ) at the exit of the probe.

**SP3** Diluted exhaust gas CO, CO<sub>2</sub>, NO<sub>x</sub> sampling probe (Figure 8 only)

The probe must:

- be in the same plane as SP 2;
- be sufficiently distant (radially) from other probes and the tunnel wall so as to be free from the influence of any wakes or eddies;
- be heated and insulated over its entire length to a minimum temperature of  $328\text{ K}$  ( $55^{\circ}\text{C}$ ) to prevent water condensation.

**HSL1** Heated sampling line

The sampling line provides a gas sample from a single probe to the split point(s) and the HC analyser.

The sampling line must:

- have a 5 mm minimum and a 13.5 mm maximum inside diameter;
- be made of stainless steel or PTFE.
- maintain a wall temperature of  $463\text{ K} \pm 10\text{ K}$  ( $190^{\circ}\text{C} \pm 10^{\circ}\text{C}$ ) as measured at every separately controlled heated section, if the temperature of the exhaust gas at the sampling probe is equal to or below  $463\text{ K}$  ( $190^{\circ}\text{C}$ );
- maintain a wall temperature greater than  $453\text{ K}$  ( $180^{\circ}\text{C}$ ), if the temperature of the exhaust gas at the sampling probe is above  $463\text{ K}$  ( $190^{\circ}\text{C}$ );
- maintain a gas temperature of  $463\text{ K} \pm 10\text{ K}$  ( $190^{\circ}\text{C} \pm 10^{\circ}\text{C}$ ) immediately before the heated filter F2 and the HFID;

**HSL2** Heated NO<sub>x</sub> sampling line

The sampling line must:

- maintain a wall temperature of 328 K to 473 K (55°C to 200°C), up to the converter C when using a cooling bath B, and up to the analyser when a cooling bath B is not used.
- be made of stainless steel or PTFE.

**SL** Sampling line for CO and CO<sub>2</sub>

The line must be made of PTFE or stainless steel. It may be heated or unheated.

**BK** Background bag (optional; Figure 8 only)

For the sampling of the background concentrations

**BG** Sample bag (optional; Figure 8 CO and CO<sub>2</sub> only)

For the sampling of the sample concentrations.

**F1** Heated pre-filter (optional)

The temperature must be the same as HSL1.

**F2** Heated filter

The filter must extract any solid particles from the gas sample prior to the analyser. The temperature must be the same as HSL1. The filter must be changed as needed.

**P** Heated sampling pump

The pump must be heated to the temperature of HSL1.

**HC** Heated flame ionisation detector (HFID) for the determination of the hydrocarbons.

The temperature must be kept at 453 K to 473 K (180°C to 200°C).

**CO, CO<sub>2</sub>** NDIR analysers for the determination of carbon monoxide and carbon dioxide (optional for the determination of the dilution ratio for PT measurement).

**NO** CLD or HCLD analyser for the determination of the oxides of nitrogen.

If a HCLD is used it must be kept at a temperature of 328 K to 473 K (55°C to 200°C).

**C** Converter

A converter must be used for the catalytic reduction of NO<sub>2</sub> to NO prior to analysis in the CLD or HCLD.

**B** Cooling bath (optional)

To cool and condense water from the exhaust sample. The bath must be maintained at a temperature of 273 K to 277 K (0°C to 4°C) by ice or refrigeration. It is optional if the analyser is free from water vapour interference as determined in annex 4, appendix 5, paragraphs 1.9.1. and 1.9.2. If water is removed by condensation, the sample gas temperature or dew point must be monitored either within the water trap or downstream. The sample gas temperature or dew point must not exceed 280 K (7°C). Chemical dryers are not allowed for removing water from the sample.

**T1, T2, T3** Temperature sensor

To monitor the temperature of the gas stream.

**T4** Temperature sensor

To monitor the temperature of the NO<sub>2</sub> - NO converter.

**T5** Temperature sensor

To monitor the temperature of the cooling bath.

**G1, G2, G3** Pressure gauge

To measure the pressure in the sampling lines.

**R1, R2** Pressure regulator

To control the pressure of the air and the fuel, respectively, for the HFID.

**R3, R4, R5** Pressure regulator

To control the pressure in the sampling lines and the flow to the analysers.

**FL1, FL2, FL3** Flowmeter

To monitor the sample by-pass flow rate.

**FL4 to FL6** Flowmeter (optional)

To monitor the flow rate through the analysers.

**V1 to V5** Selector valve

Suitable valving for selecting sample, span gas or zero gas flow to the analysers.

**V6, V7** Solenoid valve

To by-pass the NO<sub>2</sub> - NO converter.

**V8** Needle valve

To balance the flow through the NO<sub>2</sub> - NO converter C and the by-pass.

**V9, V10** Needle valve

To regulate the flows to the analysers.

**V11, V12** Toggle valve (optional)

To drain the condensate from the bath B.

1.3. NMHC analysis (NG fuelled gas engines only)

1.3.1. Gas chromatographic method (GC, Figure 9)

When using the GC method, a small measured volume of a sample is injected onto an analytical column through which it is swept by an inert carrier gas. The column separates various components according to their boiling points so that they elute from the column at different times. They then pass through a detector which gives an electrical signal that depends on their concentration. Since it is not a continuous analysis technique, it can only be used in conjunction with the bag sampling method as described in annex 4, appendix 4, paragraph 3.4.2.

For NMHC an automated GC with a FID must be used. The exhaust gas must be sampled into a sampling bag from which a part must be taken and injected into the GC. The sample is separated into two parts (CH<sub>4</sub>/Air/CO and NMHC/CO<sub>2</sub>/H<sub>2</sub>O) on the Porapak column. The molecular sieve column separates CH<sub>4</sub> from the air and CO before passing it to the FID where its concentration is measured. A complete cycle from injection of one sample to injection of a second can be made in 30 s. To determine NMHC, the CH<sub>4</sub> concentration must be subtracted from the total HC concentration (see annex 4, appendix 2, paragraph 4.3.1.).

Figure 9 shows a typical GC assembled to routinely determine CH<sub>4</sub>. Other GC methods can also be used based on good engineering judgement.

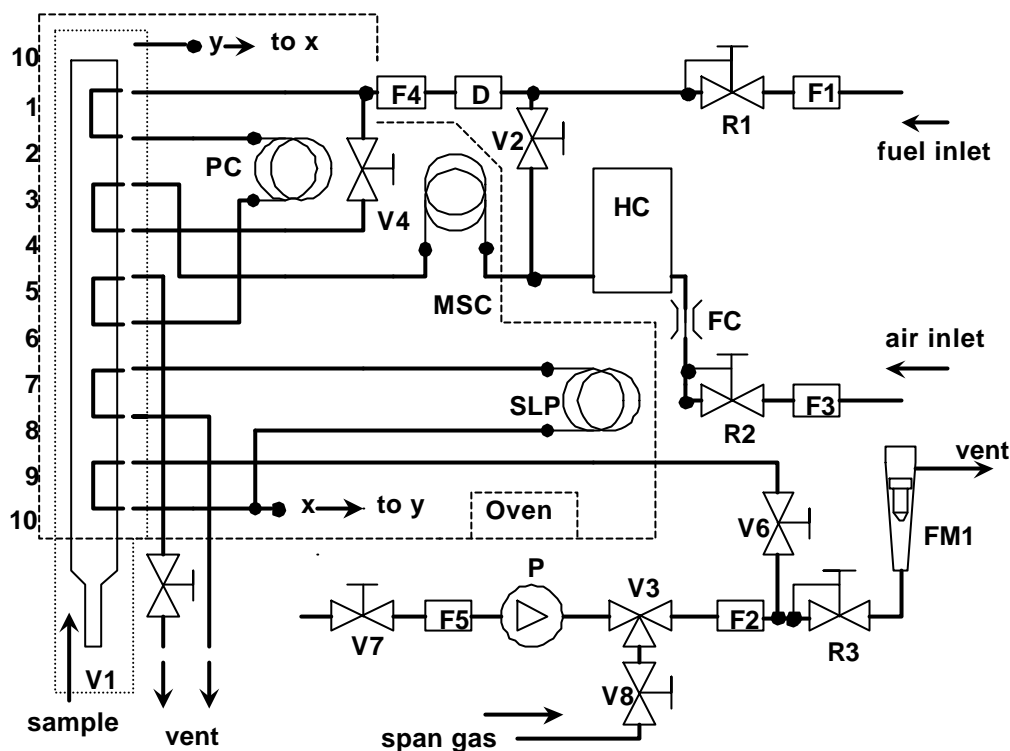

Figure 9 - Flow diagram for methane analysis (GC method)

Components of Figure 9

**PC** Porapak column

Porapak N, 180/300  $\mu\text{m}$  (50/80 mesh), 610 mm length x 2.16 mm ID must be used and conditioned at least 12 h at 423 K (150°C) with carrier gas prior to initial use.

**MSC** Molecular sieve column

Type 13X, 250/350  $\mu\text{m}$  (45/60 mesh), 1220 mm length x 2.16 mm ID must be used and conditioned at least 12 h at 423 K (150°C) with carrier gas prior to initial use.

**OV** Oven

To maintain columns and valves at stable temperature for analyser operation, and to condition the columns at 423 K (150°C).

**SLP** Sample loop

A sufficient length of stainless steel tubing to obtain approximately 1  $\text{cm}^3$  volume.

**P** Pump

To bring the sample to the gas chromatograph.

**D** Dryer

A dryer containing molecular sieve must be used to remove water and other contaminants which might be present in the carrier gas.

**HC** Flame ionisation detector (FID) to measure the concentration of methane.

**V1** Sample injection valve

To inject the sample taken from the sampling bag via SL of Figure 8. It must be low dead volume, gas tight, and heatable to 423 K (150°C).

**V3** Selector valve

To select span gas, sample, or no flow.

**V2, V4, V5, V6, V7, V8** Needle valve

To set the flows in the system.

**R1, R2, R3** Pressure regulator

To control the flows of the fuel (= carrier gas), the sample, and the air, respectively.

**FC** Flow capillary

To control the rate of air flow to the FID

**G1, G2, G3** Pressure gauge

To control the flows of the fuel (= carrier gas), the sample, and the air, respectively.

**F1, F2, F3, F4, F5** Filter

Sintered metal filters to prevent grit from entering the pump or the instrument.

**FL1** Flowmeter

To measure the sample bypass flow rate.

#### 1.3.2. Non-methane cutter method (NMC, Figure 10)

The cutter oxidises all hydrocarbons except CH<sub>4</sub> to CO<sub>2</sub> and H<sub>2</sub>O, so that by passing the sample through the NMC only CH<sub>4</sub> is detected by the FID. If bag sampling is used, a flow diverter system must be installed at SL (see paragraph 1.2., Figure 8) with which the flow can be alternatively passed through or around the cutter according to



the upper part of Figure 10. For NMHC measurement, both values (HC and CH<sub>4</sub>) must be observed on the FID and recorded. If the integration method is used, an NMC in line with a second FID must be installed parallel to the regular FID into HSL1 (see paragraph 1.2., Figure 8) according to the lower part of Figure 10. For NMHC measurement, the values of the two FID's (HC and CH<sub>4</sub>) must be observed and recorded.

The cutter must be characterised at or above 600 K (327°C) prior to test work with respect to its catalytic effect on CH<sub>4</sub> and C<sub>2</sub>H<sub>6</sub> at H<sub>2</sub>O values representative of exhaust stream conditions. The dew point and O<sub>2</sub> level of the sampled exhaust stream must be known. The relative response of the FID to CH<sub>4</sub> must be recorded (see annex 4, appendix 5, paragraph 1.8.2.).

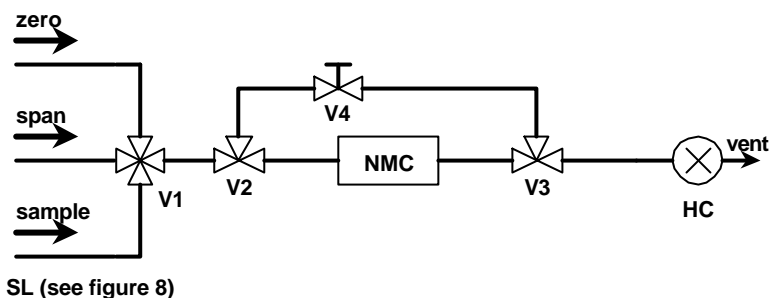

**Bag Sampling Method**

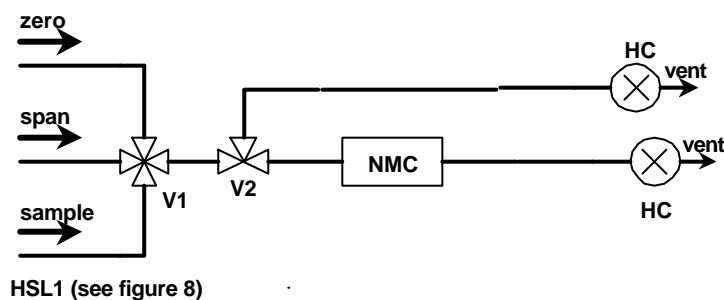

**Integrating Method**

Figure 10 - Flow diagram for methane analysis with the non-methane cutter (NMC)

Components of Figure 10

**NMC** Non-methane cutter

To oxidise all hydrocarbons except methane.

**HC** Heated flame ionisation detector (HFID)

To measure the HC and CH<sub>4</sub> concentrations. The temperature must be kept at 453 K to 473 K (180°C to 200°C).

**V1** Selector valve

To select sample, zero and span gas. V1 is identical with V2 of Figure 8.

**V2, V3** Solenoid valve

To by-pass the NMC

**V4** Needle valve

To balance the flow through the NMC and the by-pass.

**R1** Pressure regulator

To control the pressure in the sampling line and the flow to the HFID. R1 is identical with R3 of Figure 8.

**FL1** Flowmeter

To measure the sample by-pass flow rate. FL1 is identical with FL1 of Figure 8.

## 2. EXHAUST GAS DILUTION AND DETERMINATION OF THE PARTICULATES

### 2.1. Introduction

Paragraphs 2.2., 2.3. and 2.4. and figures 11 to 22 contain detailed descriptions of the recommended dilution and sampling systems. Since various configurations can produce equivalent results, exact conformance with these figures is not required. Additional components such as instruments, valves, solenoids, pumps, and switches may be used to provide additional information and coordinate the functions of the component systems. Other components which are not needed to maintain the accuracy on some systems, may be excluded if their exclusion is based upon good engineering judgement.

### 2.2. Partial flow dilution system

A dilution system is described in figures 11 to 19 based upon the dilution of a part of the exhaust stream. Splitting of the exhaust stream and the following dilution process may be done by different dilution system types. For subsequent collection of the particulates, the entire dilute exhaust gas or only a portion of the dilute exhaust gas is passed to the particulate sampling system (paragraph 2.4., Figure 21). The first method is referred to as total sampling type, the second method as fractional sampling type.

The calculation of the dilution ratio depends upon the type of system used. The following types are recommended:

Isokinetic systems (Figures 11, 12)

With these systems, the flow into the transfer tube is matched to the bulk exhaust flow in terms of gas velocity and/or pressure, thus requiring an undisturbed and uniform exhaust flow at the sampling

probe. This is usually achieved by using a resonator and a straight approach tube upstream of the sampling point. The split ratio is then calculated from easily measurable values like tube diameters. It should be noted that isokinesis is only used for matching the flow conditions and not for matching the size distribution. The latter is typically not necessary, as the particles are sufficiently small as to follow the fluid streamlines.

Flow controlled systems with concentration measurement (Figures 13 to 17)

With these systems, a sample is taken from the bulk exhaust stream by adjusting the dilution air flow and the total dilute exhaust flow. The dilution ratio is determined from the concentrations of tracer gases, such as CO<sub>2</sub> or NO<sub>x</sub>, naturally occurring in the engine exhaust. The concentrations in the dilute exhaust gas and in the dilution air are measured, whereas the concentration in the raw exhaust gas can be either measured directly or determined from fuel flow and the carbon balance equation, if the fuel composition is known. The systems may be controlled by the calculated dilution ratio (figures 13, 14) or by the flow into the transfer tube (figures 12, 13, 14).

Flow controlled systems with flow measurement (Figures 18, 19)

With these systems, a sample is taken from the bulk exhaust stream by setting the dilution air flow and the total dilute exhaust flow. The dilution ratio is determined from the difference of the two flow rates. Accurate calibration of the flow meters relative to one another is required, since the relative magnitude of the two flow rates can lead to significant errors at higher dilution ratios (of 15 and above). Flow control is very straightforward by keeping the dilute exhaust flow rate constant and varying the dilution air flow rate, if needed.

When using partial flow dilution systems, attention must be paid to avoiding the potential problems of loss of particulates in the transfer tube, ensuring that a representative sample is taken from the engine exhaust, and determination of the split ratio. The systems described pay attention to these critical areas.

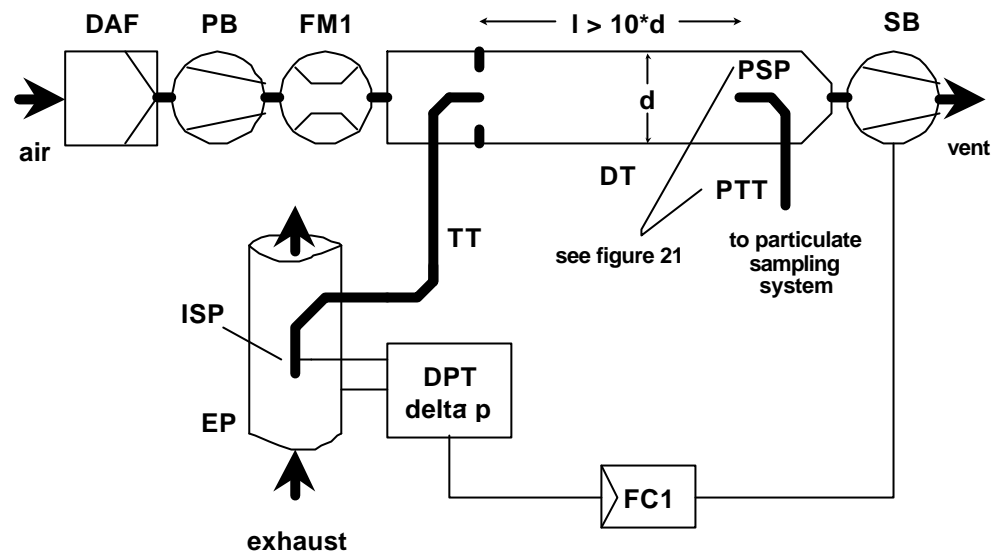

Figure 11 - Partial flow dilution system with isokinetic probe and fractional sampling (SB control)

Raw exhaust gas is transferred from the exhaust pipe EP to the dilution tunnel DT through the transfer tube TT by the isokinetic sampling probe ISP. The differential pressure of the exhaust gas between exhaust pipe and inlet to the probe is measured with the pressure transducer DPT. This signal is transmitted to the flow controller FC1 that controls the suction blower SB to maintain a differential pressure of zero at the tip of the probe. Under these conditions, exhaust gas velocities in EP and ISP are identical, and the flow through ISP and TT is a constant fraction (split) of the exhaust gas flow. The split ratio is determined from the cross sectional areas of EP and ISP. The dilution air flow rate is measured with the flow measurement device FM1. The dilution ratio is calculated from the dilution air flow rate and the split ratio.

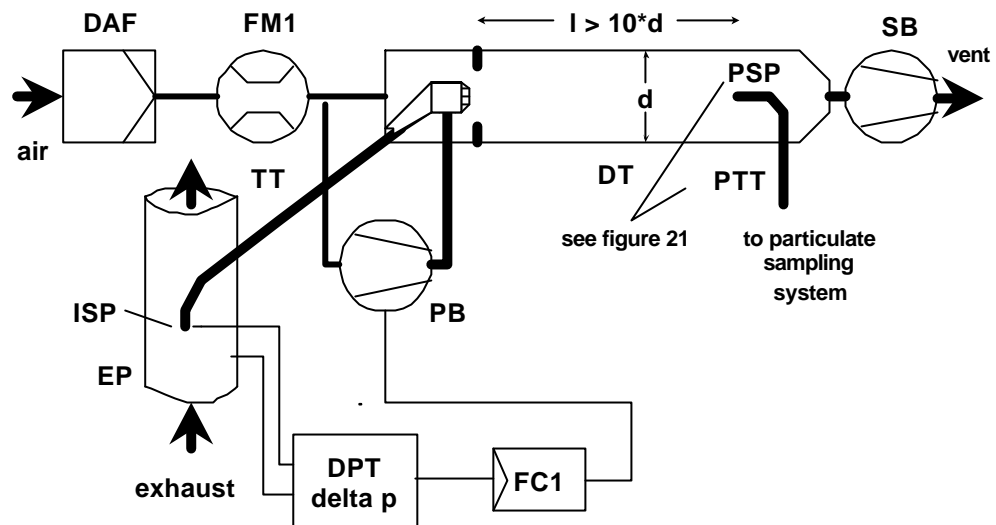

Figure 12 - Partial flow dilution system with isokinetic probe and fractional sampling (PB control)

Raw exhaust gas is transferred from the exhaust pipe EP to the dilution tunnel DT through the transfer tube TT by the isokinetic sampling probe ISP. The differential pressure of the exhaust gas between exhaust pipe and inlet to the probe is measured with the pressure transducer DPT. This signal is transmitted to the flow controller FC1 that controls the pressure blower PB to maintain a differential pressure of zero at the tip of the probe. This is done by taking a small fraction of the dilution air whose flow rate has already been measured with the flow measurement device FM1, and feeding it to TT by means of a pneumatic orifice. Under these conditions, exhaust gas velocities in EP and ISP are identical, and the flow through ISP and TT is a constant fraction (split) of the exhaust gas flow. The split ratio is determined from the cross sectional areas of EP and ISP. The dilution air is sucked through DT by the suction blower SB, and the flow rate is measured with FM1 at the inlet to DT. The dilution ratio is calculated from the dilution air flow rate and the split ratio.

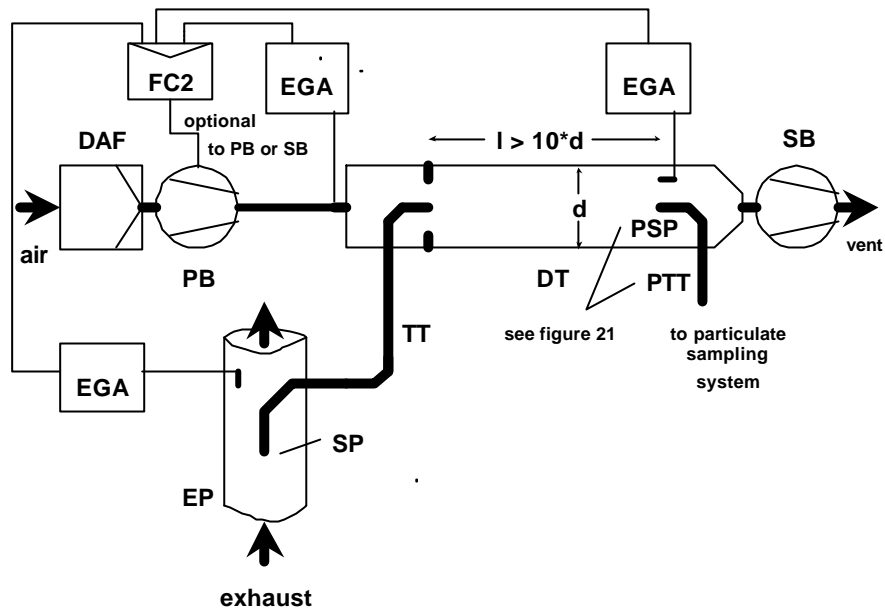

Figure 13 - Partial flow dilution system with  $\text{CO}_2$  or  $\text{NO}_x$  concentration measurement and fractional sampling

Raw exhaust gas is transferred from the exhaust pipe EP to the dilution tunnel DT through the sampling probe SP and the transfer tube TT. The concentrations of a tracer gas ( $\text{CO}_2$  or  $\text{NO}_x$ ) are measured in the raw and diluted exhaust gas as well as in the dilution air with the exhaust gas analyser(s) EGA. These signals are transmitted to the flow controller FC2 that controls either the pressure blower PB or the suction blower SB to maintain the desired exhaust split and dilution ratio in DT. The dilution ratio is calculated from the tracer gas concentrations in the raw exhaust gas, the diluted exhaust gas, and the dilution air.

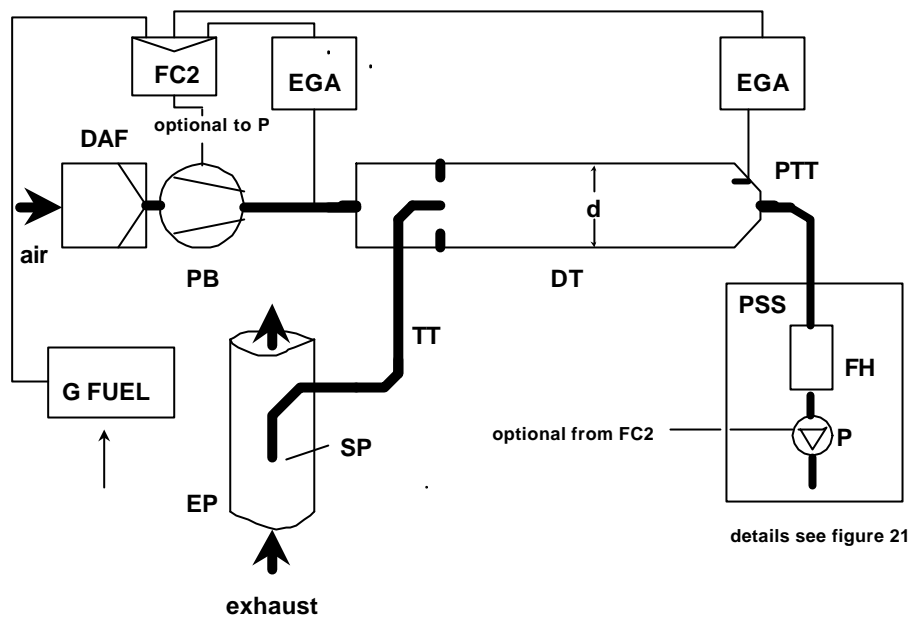

Figure 14 - Partial flow dilution system with CO<sub>2</sub> concentration measurement, carbon balance and total sampling

Raw exhaust gas is transferred from the exhaust pipe EP to the dilution tunnel DT through the sampling probe SP and the transfer tube TT. The CO<sub>2</sub> concentrations are measured in the diluted exhaust gas and in the dilution air with the exhaust gas analyser(s) EGA. The CO<sub>2</sub> and fuel flow  $G_{FUEL}$  signals are transmitted either to the flow controller FC2, or to the flow controller FC3 of the particulate sampling system (see Figure 21). FC2 controls the pressure blower PB, FC3 the sampling pump P (see Figure 21), thereby adjusting the flows into and out of the system so as to maintain the desired exhaust split and dilution ratio in DT. The dilution ratio is calculated from the CO<sub>2</sub> concentrations and  $G_{FUEL}$  using the carbon balance assumption.

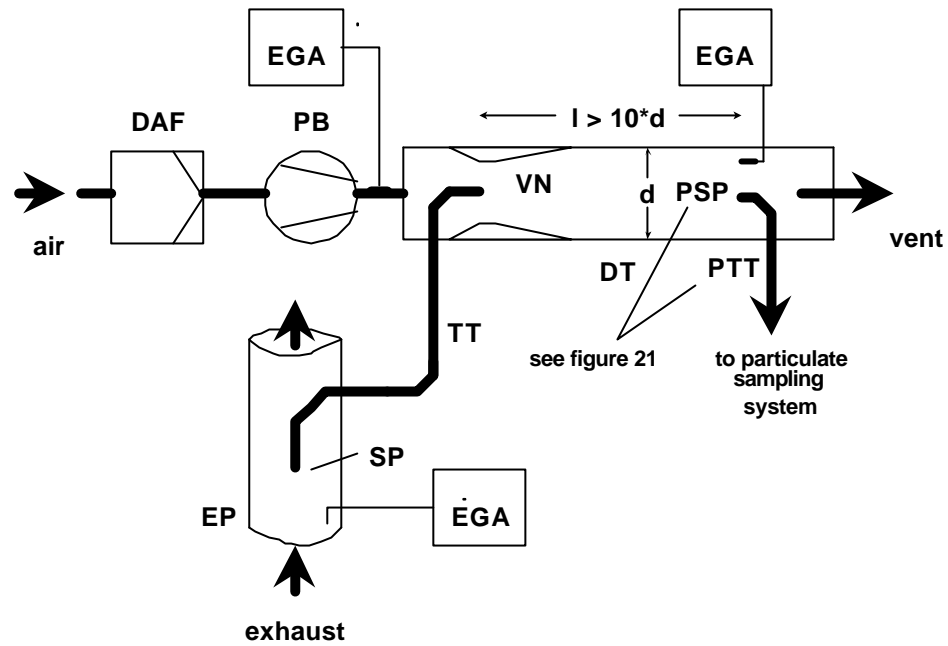

Figure 15 - Partial flow dilution system with single venturi, concentration measurement and fractional sampling

Raw exhaust gas is transferred from the exhaust pipe EP to the dilution tunnel DT through the sampling probe SP and the transfer tube TT due to the negative pressure created by the venturi VN in DT. The gas flow rate through TT depends on the momentum exchange at the venturi zone, and is therefore affected by the absolute temperature of the gas at the exit of TT. Consequently, the exhaust split for a given tunnel flow rate is not constant, and the dilution ratio at low load is slightly lower than at high load. The tracer gas concentrations ( $\text{CO}_2$  or  $\text{NO}_x$ ) are measured in the raw exhaust gas, the diluted exhaust gas, and the dilution air with the exhaust gas analyser(s) EGA, and the dilution ratio is calculated from the values so measured.



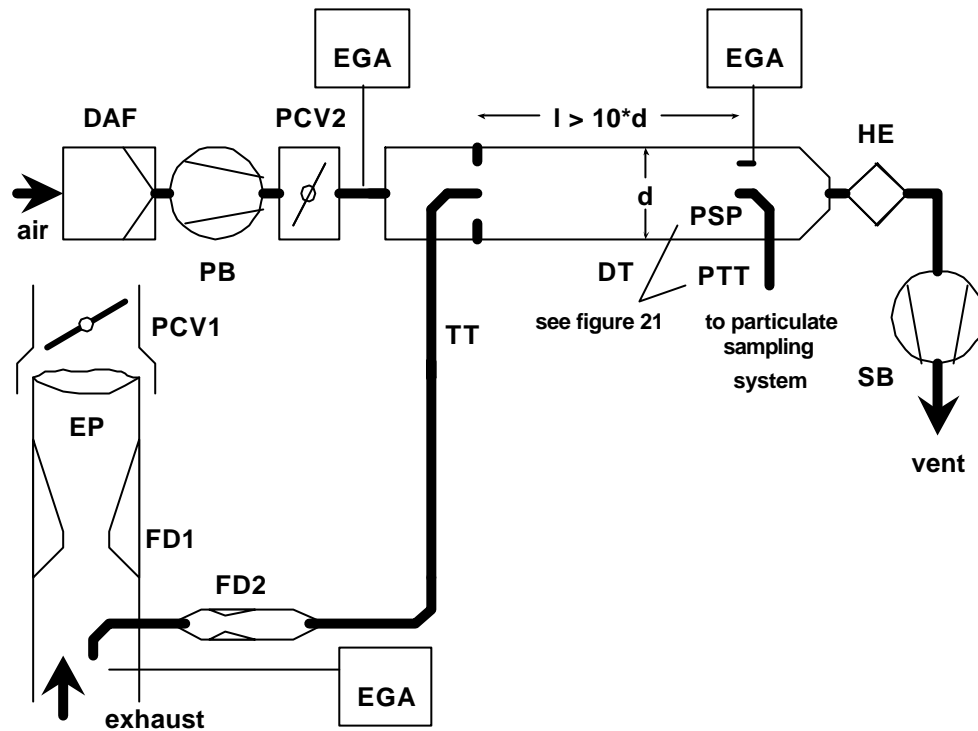

Figure 16 - Partial flow dilution system with twin venturi or twin orifice, concentration measurement and fractional sampling

Raw exhaust gas is transferred from the exhaust pipe EP to the dilution tunnel DT through the sampling probe SP and the transfer tube TT by a flow divider that contains a set of orifices or venturis. The first one (FD1) is located in EP, the second one (FD2) in TT. Additionally, two pressure control valves (PCV1 and PCV2) are necessary to maintain a constant exhaust split by controlling the back-pressure in EP and the pressure in DT. PCV1 is located downstream of SP in EP, PCV2 between the pressure blower PB and DT. The tracer gas concentrations ( $\text{CO}_2$  or  $\text{NO}_x$ ) are measured in the raw exhaust gas, the diluted exhaust gas, and the dilution air with the exhaust gas analyser(s) EGA. They are necessary for checking the exhaust split, and may be used to adjust PCV1 and PCV2 for precise split control. The dilution ratio is calculated from the tracer gas concentrations.

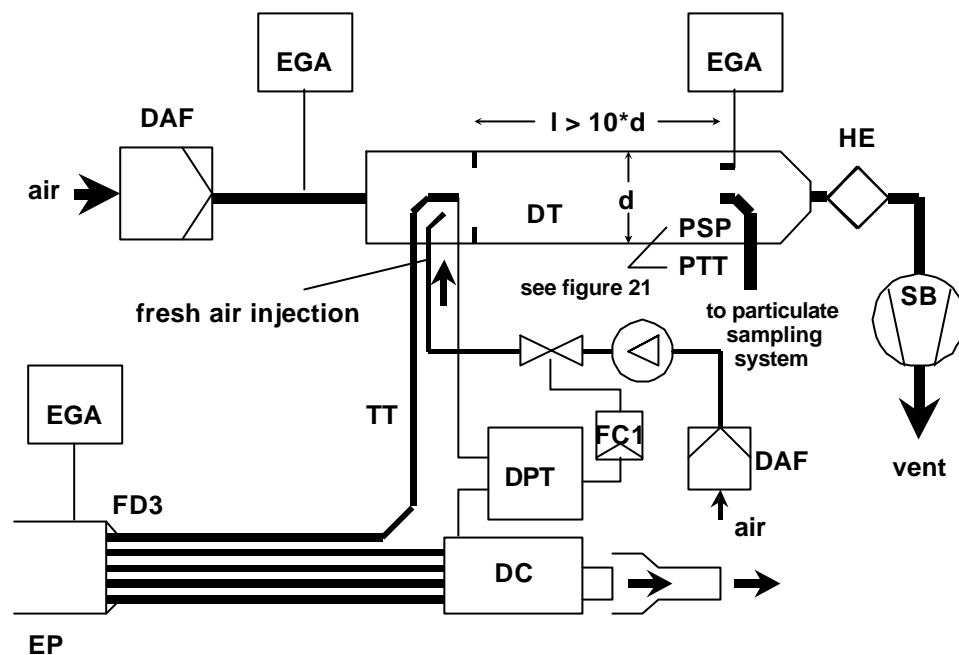

Figure 17 - Partial flow dilution system with multiple tube splitting, concentration measurement and fractional sampling

Raw exhaust gas is transferred from the exhaust pipe EP to the dilution tunnel DT through the transfer tube TT by the flow divider FD3 that consists of a number of tubes of the same dimensions (same diameter, length and bend radius) installed in EP. The exhaust gas through one of these tubes is lead to DT, and the exhaust gas through the rest of the tubes is passed through the damping chamber DC. Thus, the exhaust split is determined by the total number of tubes. A constant split control requires a differential pressure of zero between DC and the outlet of TT, which is measured with the differential pressure transducer DPT. A differential pressure of zero is achieved by injecting fresh air into DT at the outlet of TT. The tracer gas concentrations ( $\text{CO}_2$  or  $\text{NO}_x$ ) are measured in the raw exhaust gas, the diluted exhaust gas, and the dilution air with the exhaust gas analyser(s) EGA. They are necessary for checking the exhaust split and may be used to control the injection air flow rate for precise split control. The dilution ratio is calculated from the tracer gas concentrations.

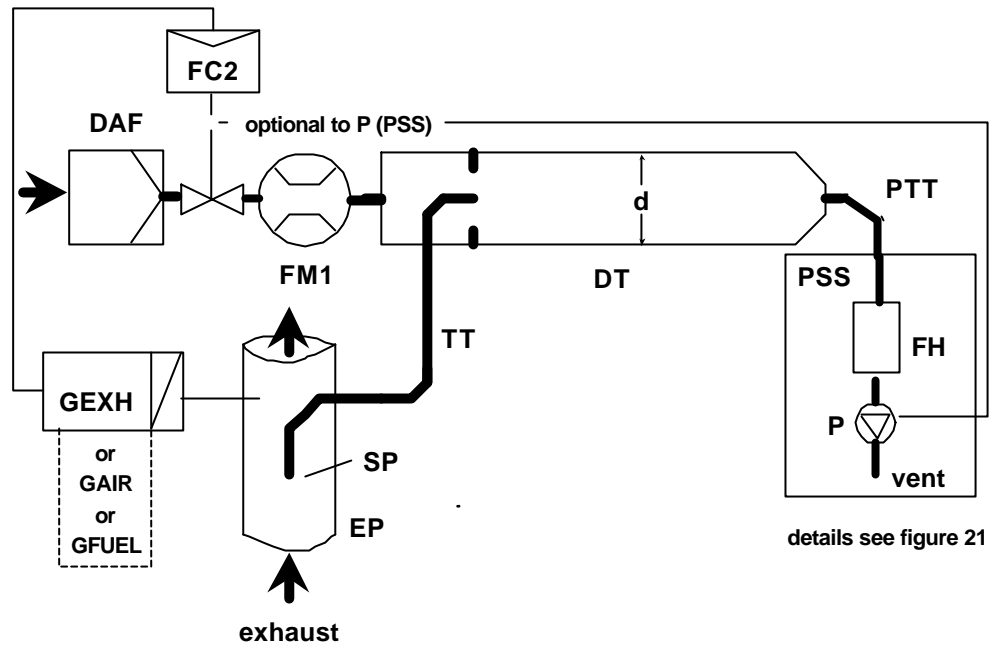

Figure 18 - Partial flow dilution system with flow control and total sampling

Raw exhaust gas is transferred from the exhaust pipe EP to the dilution tunnel DT through the sampling probe SP and the transfer tube TT. The total flow through the tunnel is adjusted with the flow controller FC3 and the sampling pump P of the particulate sampling system (see Figure 18). The dilution air flow is controlled by the flow controller FC2, which may use  $G_{EXHW}$ ,  $G_{AIRW}$ , or  $G_{FUEL}$  as command signals, for the desired exhaust split. The sample flow into DT is the difference of the total flow and the dilution air flow. The dilution air flow rate is measured with the flow measurement device FM1, the total flow rate with the flow measurement device FM3 of the particulate sampling system (see Figure 21). The dilution ratio is calculated from these two flow rates.

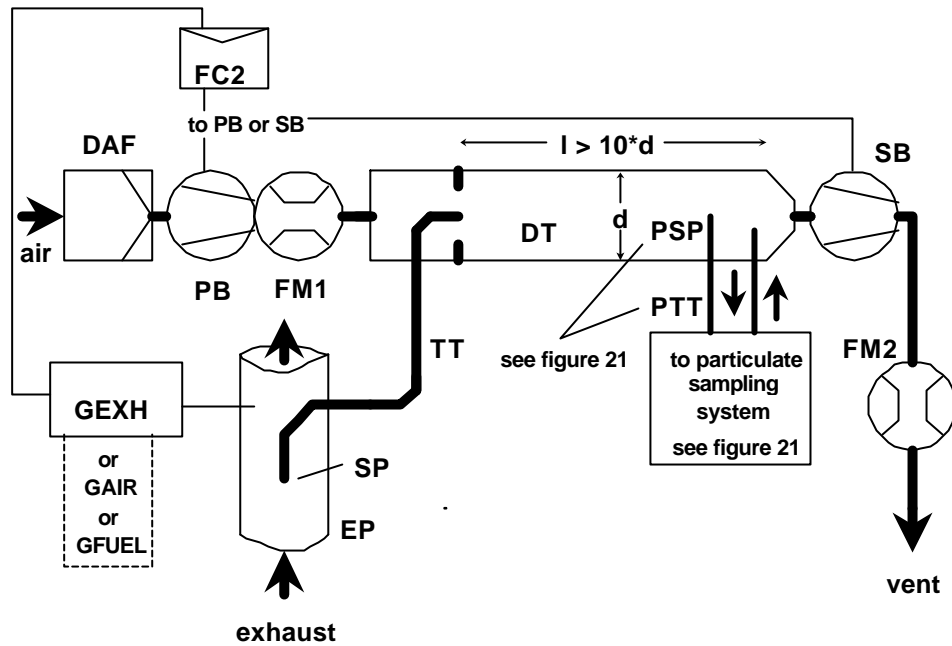

Figure 19 - Partial flow dilution system with flow control and fractional sampling

Raw exhaust gas is transferred from the exhaust pipe EP to the dilution tunnel DT through the sampling probe SP and the transfer tube TT. The exhaust split and the flow into DT is controlled by the flow controller FC2 that adjusts the flows (or speeds) of the pressure blower PB and the suction blower SB, accordingly. This is possible since the sample taken with the particulate sampling system is returned into DT.  $G_{EXHW}$ ,  $G_{AIRW}$ , or  $G_{FUEL}$  may be used as command signals for FC2. The dilution air flow rate is measured with the flow measurement device FM1, the total flow with the flow measurement device FM2. The dilution ratio is calculated from these two flow rates.

## 2.2.1. Components of figures 11 to 19

**EP** Exhaust pipe

The exhaust pipe may be insulated. To reduce the thermal inertia of the exhaust pipe a thickness to diameter ratio of 0.015 or less is recommended. The use of flexible sections must be limited to a length to diameter ratio of 12 or less. Bends must be minimised to reduce inertial deposition. If the system includes a test bed silencer the silencer may also be insulated.

For an isokinetic system, the exhaust pipe must be free of elbows, bends and sudden diameter changes for at least 6 pipe diameters upstream and 3 pipe diameters downstream of the tip of the probe. The gas velocity at the sampling zone must be higher than 10 m/s except at idle mode. Pressure oscillations of the exhaust gas must not exceed  $\pm 500$  Pa on the average. Any steps to reduce pressure oscillations beyond using a chassis-type exhaust system (including silencer and after-treatment devices) must not alter engine performance nor cause the deposition of particulates.

For systems without isokinetic probe, it is recommended to have a straight pipe of 6 pipe diameters upstream and 3 pipe diameters downstream of the tip of the probe.

**SP** Sampling probe (Figures 10, 14, 15, 16, 18, 19)

The minimum inside diameter must be 4 mm. The minimum diameter ratio between exhaust pipe and probe must be 4. The probe must be an open tube facing upstream on the exhaust pipe centreline, or a multiple hole probe as described under SP1 in paragraph 1.2.1., Figure 5.

**ISP** Isokinetic sampling probe (Figures 11, 12)

The isokinetic sampling probe must be installed facing upstream on the exhaust pipe centreline where the flow conditions in paragraph EP are met, and designed to provide a proportional sample of the raw exhaust gas. The minimum inside diameter must be 12 mm.

A control system is necessary for isokinetic exhaust splitting by maintaining a differential pressure of zero between EP and ISP. Under these conditions exhaust gas velocities in EP and ISP are identical and the mass flow through ISP is a constant fraction of the exhaust gas flow. ISP has to be connected to a differential pressure transducer DPT. The control to provide a differential pressure of zero between EP and ISP is done with the flow controller FC1.

**FD1, FD2** Flow divider (Figure 16)

A set of venturis or orifices is installed in the exhaust pipe EP and in the transfer tube TT, respectively, to provide a proportional sample of the raw exhaust gas. A control system consisting of two pressure control valves PCV1 and PCV2 is necessary for proportional splitting by controlling the pressures in EP and DT.

**FD3** Flow divider (Figure 17)

A set of tubes (multiple tube unit) is installed in the exhaust pipe EP to provide a proportional sample of the raw exhaust gas. One of the tubes feeds exhaust gas to the dilution tunnel DT, whereas the other tubes exit exhaust gas to a damping chamber DC. The tubes must have the same dimensions (same diameter, length, bend radius), so that the exhaust split depends on the total number of tubes. A control system is necessary for proportional splitting by maintaining a differential pressure of zero between the exit of the multiple tube unit into DC and the exit of TT. Under these conditions, exhaust gas velocities in EP and FD3 are proportional, and the flow TT is a constant fraction of the exhaust gas flow. The two points have to be connected to a differential pressure transducer DPT. The control to provide a differential pressure of zero is done with the flow controller FC1.

**EGA** Exhaust gas analyser (Figures 13, 14, 15, 16, 17)

CO<sub>2</sub> or NO<sub>x</sub> analysers may be used (with carbon balance method CO<sub>2</sub> only). The analysers must be calibrated like the analysers for the measurement of the gaseous emissions. One or several analysers may be used to determine the concentration differences. The accuracy of the measuring systems has to be such that the accuracy of G<sub>EDFW,i</sub> is within ± 4 per cent.

**TT** Transfer tube (Figures 11 to 19)

The transfer tube must be:

- As short as possible, but not more than 5 m in length.
- Equal to or greater than the probe diameter, but not more than 25 mm in diameter.
- Exiting on the centreline of the dilution tunnel and pointing downstream.

If the tube is 1 meter or less in length, it must be insulated with material with a maximum thermal conductivity of 0.05 W/m\*K with a radial insulation thickness corresponding to the diameter of the probe. If the tube is longer than 1 meter, it must be insulated and heated to a minimum wall temperature of 523 K (250°C).

**DPT** Differential pressure transducer (Figures 11, 12, 17)

The differential pressure transducer must have a range of ± 500 Pa or less.

**FC1** Flow controller (Figures 11, 12, 17)

For isokinetic systems (figures 11, 12), a flow controller is necessary to maintain a differential pressure of zero between EP and ISP. The adjustment can be done by:

- (a) controlling the speed or flow of the suction blower SB and keeping the speed or flow of the pressure blower PB constant during each mode (Figure 11) or
- (b) adjusting the suction blower SB to a constant mass flow of the diluted exhaust gas and controlling the flow of the pressure blower PB, and therefore the exhaust sample flow in a region at the end of the transfer tube TT (Figure 12).

In the case of a pressure controlled system the remaining error in the control loop must not exceed  $\pm 3$  Pa. The pressure oscillations in the dilution tunnel must not exceed  $\pm 250$  Pa on the average.

For a multi tube system (Figure 17), a flow controller is necessary for proportional exhaust splitting to maintain a differential pressure of zero between the exit of the multi tube unit and the exit of TT. The adjustment is done by controlling the injection air flow rate into DT at the exit of TT.

**PCV1, PCV2** Pressure control valve (Figure 16)

Two pressure control valves are necessary for the twin venturi/twin orifice system for proportional flow splitting by controlling the back-pressure of EP and the pressure in DT. The valves must be located downstream of SP in EP and between PB and DT.

**DC** Damping chamber (Figure 17)

A damping chamber must be installed at the exit of the multiple tube unit to minimise the pressure oscillations in the exhaust pipe EP.

**VN** Venturi (Figure 15)

A venturi is installed in the dilution tunnel DT to create a negative pressure in the region of the exit of the transfer tube TT. The gas flow rate through TT is determined by the momentum exchange at the venturi zone, and is basically proportional to the flow rate of the pressure blower PB leading to a constant dilution ratio. Since the momentum exchange is affected by the temperature at the exit of TT and the pressure difference between EP and DT, the actual dilution ratio is slightly lower at low load than at high load.

**FC2** Flow controller (Figures 13, 14, 18, 19; optional)

A flow controller may be used to control the flow of the pressure blower PB and/or the suction blower SB. It may be connected to the exhaust, intake air, or fuel flow signals and/or to the CO<sub>2</sub> or NO<sub>x</sub> differential signals.

When using a pressurised air supply (Figure 18), FC2 directly controls the air flow.

**FM1** Flow measurement device (Figures 11, 12, 18, 19)

Gas meter or other flow instrumentation to measure the dilution air flow. FM1 is optional if the pressure blower PB is calibrated to measure the flow.

**FM2** Flow measurement device (Figure 19)

Gas meter or other flow instrumentation to measure the diluted exhaust gas flow. FM2 is optional if the suction blower SB is calibrated to measure the flow.

**PB** Pressure blower (Figures 11, 12, 13, 14, 15, 16, 19)

To control the dilution air flow rate, PB may be connected to the flow controllers FC1 or FC2. PB is not required when using a butterfly valve. PB may be used to measure the dilution air flow, if calibrated.

**SB** Suction blower (figures 11, 12, 13, 16, 17, 19)

For fractional sampling systems only. SB may be used to measure the diluted exhaust gas flow, if calibrated.

**DAF** Dilution air filter (Figures 11 to 19)

It is recommended that the dilution air be filtered and charcoal scrubbed to eliminate background hydrocarbons. At the engine manufacturers request the dilution air must be sampled according to good engineering practice to determine the background particulate levels, which can then be subtracted from the values measured in the diluted exhaust.

**DT** Dilution tunnel (Figures 11 to 19)

The dilution tunnel:

- must be of a sufficient length to cause complete mixing of the exhaust and dilution air under turbulent flow conditions;
- must be constructed of stainless steel with:
  - thickness/diameter ratio of 0.025 or less for dilution tunnels with inside diameters greater than 75 mm;
  - a nominal thickness of no less than 1.5 mm for dilution tunnels with inside diameters of equal to or less than 75 mm;
- must be at least 75 mm in diameter for the fractional sampling type;
- is recommended to be at least 25 mm in diameter for the total sampling type;



- may be heated to no greater than 325 K (52°C) wall temperature by direct heating or by dilution air pre-heating, provided the air temperature does not exceed 325 K (52°C) prior to the introduction of the exhaust in the dilution tunnel;
- may be insulated.

The engine exhaust must be thoroughly mixed with the dilution air. For fractional sampling systems, the mixing quality must be checked after introduction into service by means of a CO<sub>2</sub> -profile of the tunnel with the engine running (at least four equally spaced measuring points). If necessary, a mixing orifice may be used.

Note: If the ambient temperature in the vicinity of the dilution tunnel (DT) is below 293K (20°C), precautions should be taken to avoid particle losses onto the cool walls of the dilution tunnel. Therefore, heating and/or insulating the tunnel within the limits given above is recommended.

At high engine loads, the tunnel may be cooled by a non-aggressive means such as a circulating fan, as long as the temperature of the cooling medium is not below 293K (20°C).

**HE** Heat exchanger (Figures 16,17)

The heat exchanger must be of sufficient capacity to maintain the temperature at the inlet to the suction blower SB within  $\pm 11\text{K}$  of the average operating temperature observed during the test.

### 2.3 Full flow dilution system

A dilution system is described in Figure 20 based upon the dilution of the total exhaust using the CVS (Constant Volume Sampling) concept. The total volume of the mixture of exhaust and dilution air must be measured. Either a PDP or a CFV system may be used.

For subsequent collection of the particulates, a sample of the dilute exhaust gas is passed to the particulate sampling system (paragraph 2.4., figures 21 and 22). If this is done directly, it is referred to as single dilution. If the sample is diluted once more in the secondary dilution tunnel, it is referred to as double dilution. This is useful, if the filter face temperature requirement cannot be met with single dilution. Although partly a dilution system, the double dilution system is described as a modification of a particulate sampling system in paragraph 2.4., Figure 22, since it shares most of the parts with a typical particulate sampling system.

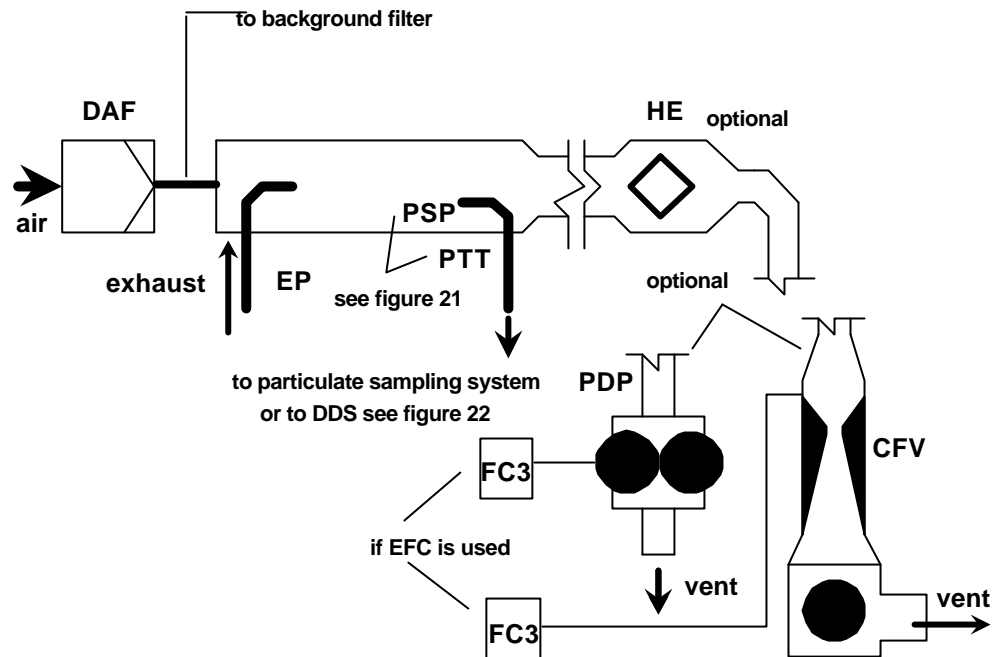

Figure 20 - Full flow dilution system

The total amount of raw exhaust gas is mixed in the dilution tunnel DT with the dilution air. The diluted exhaust gas flow rate is measured either with a Positive Displacement Pump PDP or with a Critical Flow Venturi CFV. A heat exchanger HE or electronic flow compensation EFC may be used for proportional particulate sampling and for flow determination. Since particulate mass determination is based on the total diluted exhaust gas flow, the dilution ratio is not required to be calculated.

#### 2.3.1. Components of Figure 20

**EP** Exhaust pipe

The exhaust pipe length from the exit of the engine exhaust manifold, turbocharger outlet or after-treatment device to the dilution tunnel must not exceed 10 m. If the exhaust pipe downstream of the engine exhaust manifold, turbocharger outlet or after-treatment device exceeds 4 m in length, then all tubing in excess of 4 m must be insulated, except for an in-line smokemeter, if used. The radial thickness of the insulation must be at least 25 mm. The thermal conductivity of the insulating material must have a value no greater than 0.1 W/mK measured at 673 K. To reduce the thermal inertia of the exhaust pipe a thickness to diameter ratio of 0.015 or less is recommended. The use of flexible sections must be limited to a length to diameter ratio of 12 or less.

**PDP** Positive displacement pump

The PDP meters total diluted exhaust flow from the number of the pump revolutions and the pump displacement. The exhaust system back-pressure must not be artificially lowered by the PDP or dilution air inlet system. Static exhaust back-pressure measured with the PDP system operating must remain within  $\pm 1.5$  kPa of the static pressure measured without connection to the PDP at identical engine speed and load. The gas mixture temperature immediately ahead of the PDP must be within  $\pm 6$  K of the average operating temperature observed during the test, when no flow compensation is used. Flow compensation may only be used if the temperature at the inlet to the PDP does not exceed 323K (50°C)

**CFV** Critical flow venturi

CFV measures total diluted exhaust flow by maintaining the flow at choked conditions (critical flow). Static exhaust back-pressure measured with the CFV system operating must remain within  $\pm 1.5$  kPa of the static pressure measured without connection to the CFV at identical engine speed and load. The gas mixture temperature immediately ahead of the CFV must be within  $\pm 11$  K of the average operating temperature observed during the test, when no flow compensation is used.

**HE** Heat exchanger (optional, if EFC is used)

The heat exchanger must be of sufficient capacity to maintain the temperature within the limits required above.

**EFC** Electronic flow compensation (optional, if HE is used)

If the temperature at the inlet to either the PDP or CFV is not kept within the limits stated above, a flow compensation system is required for continuous measurement of the flow rate and control of the proportional sampling in the particulate system. To that purpose, the continuously measured flow rate signals are used to correct the sample flow rate through the particulate filters of the particulate sampling system (see paragraph 2.4., figures 21, 22), accordingly.

**DT** Dilution tunnel

The dilution tunnel:

- must be small enough in diameter to cause turbulent flow (Reynolds Number greater than 4000) and of sufficient length to cause complete mixing of the exhaust and dilution air; a mixing orifice may be used;
- must be at least 460 mm in diameter with a single dilution system;

- must be at least 210 mm in diameter with a double dilution system;
- may be insulated.

The engine exhaust must be directed downstream at the point where it is introduced into the dilution tunnel, and thoroughly mixed.

When using single dilution, a sample from the dilution tunnel is transferred to the particulate sampling system (paragraph 2.4., Figure 21). The flow capacity of the PDP or CFV must be sufficient to maintain the diluted exhaust at a temperature of less than or equal to 325 K (52°C) immediately before the primary particulate filter.

When using double dilution, a sample from the dilution tunnel is transferred to the secondary dilution tunnel where it is further diluted, and then passed through the sampling filters (paragraph 2.4., Figure 22). The flow capacity of the PDP or CFV must be sufficient to maintain the diluted exhaust stream in the DT at a temperature of less than or equal to 464 K (191°C) at the sampling zone. The secondary dilution system must provide sufficient secondary dilution air to maintain the doubly-diluted exhaust stream at a temperature of less than or equal to 325 K (52°C) immediately before the primary particulate filter.

**DAF** Dilution air filter

It is recommended that the dilution air be filtered and charcoal scrubbed to eliminate background hydrocarbons. At the engine manufacturers request the dilution air must be sampled according to good engineering practice to determine the background particulate levels, which can then be subtracted from the values measured in the diluted exhaust.

**PSP** Particulate sampling probe

The probe is the leading paragraph of PTT and:

- must be installed facing upstream at a point where the dilution air and exhaust gas are well mixed, i.e. on the dilution tunnel (DT) centreline approximately 10 tunnel diameters downstream of the point where the exhaust enters the dilution tunnel;
- must be of 12 mm minimum inside diameter;
- may be heated to no greater than 325 K (52°C) wall temperature by direct heating or by dilution air pre-heating, provided the air temperature does not exceed 325 K (52°C) prior to the introduction of the exhaust in the dilution tunnel;
- may be insulated.

2.4. Particulate sampling system

The particulate sampling system is required for collecting the particulates on the particulate filter. In the case of total sampling partial flow dilution, which consists of passing the entire diluted exhaust sample through the filters, dilution (paragraph 2.2., figures 14, 18) and sampling system usually form an integral unit. In the case of fractional sampling partial flow dilution or full flow dilution, which consists of passing through the filters only a portion of the diluted exhaust, the dilution (paragraph 2.2., figures 11, 12, 13, 15, 16, 17, 19; paragraph 2.3., Figure 20) and sampling systems usually form different units.

In this Regulation, the double dilution system (Figure 22) of a full flow dilution system is considered as a specific modification of a typical particulate sampling system as shown in Figure 21. The double dilution system includes all important parts of the particulate sampling system, like filter holders and sampling pump, and additionally some dilution features, like a dilution air supply and a secondary dilution tunnel.

In order to avoid any impact on the control loops, it is recommended that the sample pump be running throughout the complete test procedure. For the single filter method, a bypass system must be used for passing the sample through the sampling filters at the desired times. Interference of the switching procedure on the control loops must be minimised.

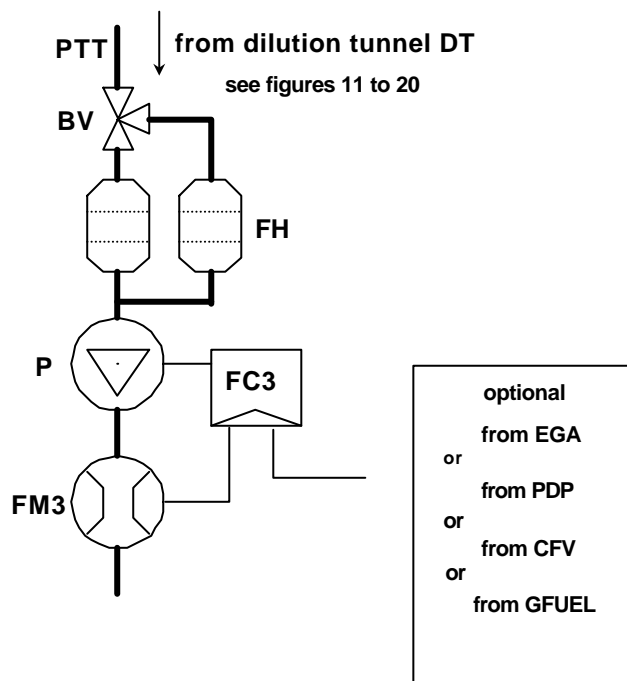

Figure 21 - Particulate sampling system

A sample of the diluted exhaust gas is taken from the dilution tunnel DT of a partial flow or full flow dilution system through the particulate sampling probe PSP and the particulate transfer tube PTT by means of the sampling pump P. The sample is passed through the filter holder(s) FH that contain the particulate sampling filters. The sample flow rate is controlled by the flow controller FC3. If electronic flow compensation EFC (see Figure 20) is used, the diluted exhaust gas flow is used as command signal for FC3.

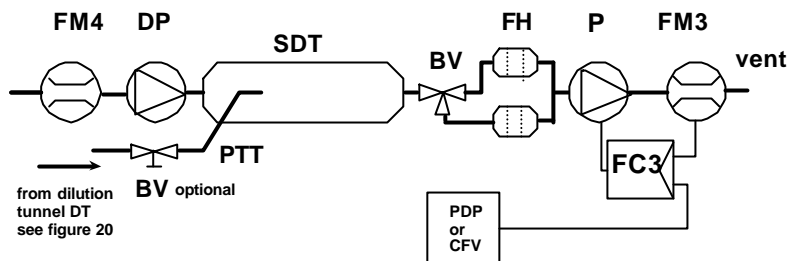

Figure 22 - Double dilution system (full flow system only)

A sample of the diluted exhaust gas is transferred from the dilution tunnel DT of a full flow dilution system through the particulate sampling probe PSP and the particulate transfer tube PTT to the secondary dilution tunnel SDT, where it is diluted once more. The sample is then passed through the filter holder(s) FH that contain the particulate sampling filters. The dilution air flow rate is usually constant whereas the sample flow rate is controlled by the flow controller FC3. If electronic flow compensation EFC (see Figure 20) is used, the total diluted exhaust gas flow is used as command signal for FC3.

#### 2.4.1. Components of figures 21 and 22

**PTT** Particulate transfer tube (Figures 21, 22)

The particulate transfer tube must not exceed 1020 mm in length, and must be minimised in length whenever possible. Where applicable (i.e. for partial flow dilution fractional sampling systems and for full flow dilution systems), the length of the sampling probes (SP, ISP, PSP, respectively, see paragraphs 2.2. and 2.3.) must be included.

The dimensions are valid for:

- the partial flow dilution fractional sampling type and the full flow single dilution system from the tip of the probe (SP, ISP, PSP, respectively) to the filter holder;
- the partial flow dilution total sampling type from the end of the dilution tunnel to the filter holder;

- the full flow double dilution system from the tip of the probe (PSP) to the secondary dilution tunnel.

The transfer tube:

- may be heated to no greater than 325K (52°C) wall temperature by direct heating or by dilution air pre-heating, provided the air temperature does not exceed 325 K (52°C) prior to the introduction of the exhaust in the dilution tunnel;
- may be insulated.

**SDT** Secondary dilution tunnel (Figure 22)

The secondary dilution tunnel should have a minimum diameter of 75 mm, and should be of sufficient length so as to provide a residence time of at least 0.25 seconds for the doubly-diluted sample. The primary filter holder FH must be located within 300 mm of the exit of the SDT.

The secondary dilution tunnel:

- may be heated to no greater than 325 K (52°C) wall temperature by direct heating or by dilution air pre-heating, provided the air temperature does not exceed 325 K (52°C) prior to the introduction of the exhaust in the dilution tunnel;
- may be insulated.

**FH** Filter holder(s) (Figures 21, 22)

For primary and back-up filters one filter housing or separate filter housings may be used. The requirements of annex 4, appendix 4, paragraph 4.1.3. must be met.

The filter holder(s):

- may be heated to no greater than 325 K (52°C) wall temperature by direct heating or by dilution air pre-heating, provided the air temperature does not exceed 325 K (52°C) prior to the introduction of the exhaust in the dilution tunnel;
- may be insulated.

**P** Sampling pump (Figures 21, 22)

The particulate sampling pump must be located sufficiently distant from the tunnel so that the inlet gas temperature is maintained constant ( $\pm 3$  K), if flow correction by FC3 is not used.

**DP** Dilution air pump (Figure 22)

The dilution air pump must be located so that the secondary dilution air is supplied at a temperature of  $298\text{ K} \pm 5\text{ K}$  ( $25^\circ\text{C} \pm 5^\circ\text{C}$ ), if the dilution air is not preheated.

**FC3** Flow controller (Figures 21, 22)

A flow controller must be used to compensate the particulate sample flow rate for temperature and back pressure variations in the sample path, if no other means are available. The flow controller is required if electronic flow compensation EFC (see Figure 20) is used.

**FM3** Flow measurement device (Figures 21, 22)

The gas meter or flow instrumentation for the particulate sample flow must be located sufficiently distant from the sampling pump P so that the inlet gas temperature remains constant ( $\pm 3\text{ K}$ ), if flow correction by FC3 is not used.

**FM4** Flow measurement device (Figure 22)

The gas meter or flow instrumentation for the dilution air flow must be located so that the inlet gas temperature remains at  $298\text{ K} \pm 5\text{ K}$  ( $25^\circ\text{C} \pm 5^\circ\text{C}$ ).

**BV** Ball valve (optional)

The ball valve must have an inside diameter not less than the inside diameter of the particulate transfer tube PTT, and a switching time of less than 0.5 seconds.

Note: If the ambient temperature in the vicinity of PSP, PTT, SDT, and FH is below  $293\text{K}$  ( $20^\circ\text{C}$ ), precautions should be taken to avoid particle losses onto the cool wall of these parts. Therefore, heating and/or insulating these parts within the limits given in the respective descriptions is recommended. It is also recommended that the filter face temperature during sampling be not below  $293\text{K}$  ( $20^\circ\text{C}$ ).

At high engine loads, the above parts may be cooled by a non-aggressive means such as a circulating fan, as long as the temperature of the cooling medium is not below  $293\text{K}$  ( $20^\circ\text{C}$ ).

3. DETERMINATION OF SMOKE OPACITY

3.1. Introduction

Paragraphs 3.2. and 3.3. and figures 23 and 24 contain detailed descriptions of the recommended opacimeter systems. Since various configurations can produce equivalent results, exact conformance with figures 23 and 24 is not required. Additional components such as instruments, valves, solenoids, pumps, and switches may be used to provide additional information and coordinate the functions of the component systems. Other components, which are not needed to



maintain the accuracy on some systems, may be excluded if their exclusion is based upon good engineering judgement.

The principle of measurement is that light is transmitted through a specific length of the smoke to be measured and that proportion of the incident light which reaches a receiver is used to assess the light obscuration properties of the medium. The smoke measurement depends upon the design of the apparatus, and may be done in the exhaust pipe (full flow in-line opacimeter), at the end of the exhaust pipe (full flow end-of-line opacimeter) or by taking a sample from the exhaust pipe (partial flow opacimeter). For the determination of the light absorption coefficient from the opacity signal, the optical path length of the instrument must be supplied by the instrument manufacturer.

### 3.2. Full Flow Opacimeter

Two general types of full flow opacimeters may be used (Figure 23). With the in-line opacimeter, the opacity of the full exhaust plume within the exhaust pipe is measured. With this type of opacimeter, the effective optical path length is a function of the opacimeter design.

With the end-of-line opacimeter, the opacity of the full exhaust plume is measured as it exits the exhaust pipe. With this type of opacimeter, the effective optical path length is a function of the exhaust pipe design and the distance between the end of the exhaust pipe and the opacimeter.

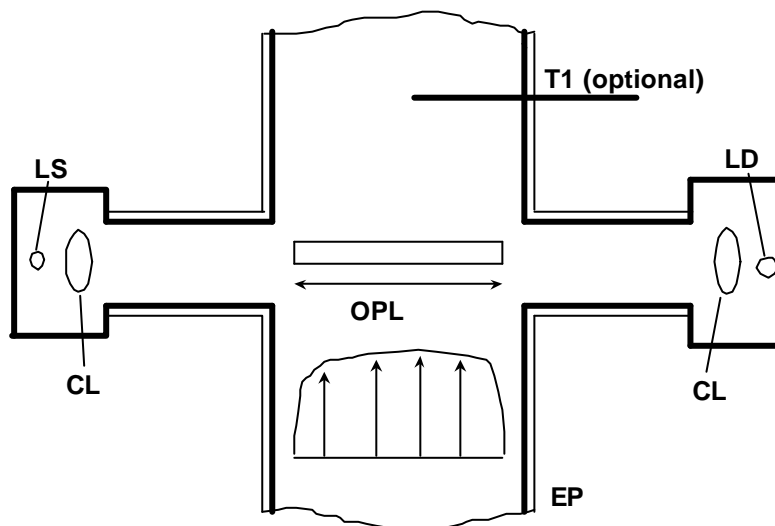

Figure 23 - Full flow opacimeter

3.2.1. Components of Figure 23

**EP** Exhaust Pipe

With an in-line opacimeter, there must be no change in the exhaust pipe diameter within 3 exhaust pipe diameters before or after the measuring zone. If the diameter of the measuring zone is greater than the diameter of the exhaust pipe, a pipe gradually convergent before the measuring zone is recommended.

With an end-of-line opacimeter, the terminal 0.6 m of the exhaust pipe must be of circular cross paragraph and be free from elbows and bends. The end of the exhaust pipe must be cut off squarely. The opacimeter must be mounted centrally to the plume within  $25 \pm 5$  mm of the end of the exhaust pipe.

**OPL** Optical Path Length

The length of the smoke obscured optical path between the opacimeter light source and the receiver, corrected as necessary for non-uniformity due to density gradients and fringe effect. The optical path length must be submitted by the instrument manufacturer taking into account any measures against sooting (e.g. purge air). If the optical path length is not available, it must be determined in accordance with ISO IDS 11614, paragraph 11.6.5. For the correct determination of the optical path length, a minimum exhaust gas velocity of 20 m/s is required.

**LS** Light source

The light source must be an incandescent lamp with a colour temperature in the range of 2800 to 3250 K or a green light emitting diode (LED) with a spectral peak between 550 and 570 nm. The light source must be protected against sooting by means that do not influence the optical path length beyond the manufacturers specifications.

**LD** Light detector

The detector must be a photocell or a photodiode (with a filter, if necessary). In the case of an incandescent light source, the receiver must have a peak spectral response similar to the photopic curve of the human eye (maximum response) in the range of 550 to 570 nm, to less than 4 per cent of that maximum response below 430 nm and above 680 nm. The light detector must be protected against sooting by means that do not influence the optical path length beyond the manufacturers specifications.

**CL** Collimating lens

The light output must be collimated to a beam with a maximum diameter of 30 mm. The rays of the light beam must be parallel within a tolerance of 3° of the optical axis.

**T1** Temperature sensor (optional)

The exhaust gas temperature may be monitored over the test.

### 3.3. Partial Flow Opacimeter

With the partial flow opacimeter (Figure 24), a representative exhaust sample is taken from the exhaust pipe and passed through a transfer line to the measuring chamber. With this type of opacimeter, the effective optical path length is a function of the opacimeter design. The response times referred to in the following paragraph apply to the minimum flow rate of the opacimeter, as specified by the instrument manufacturer.

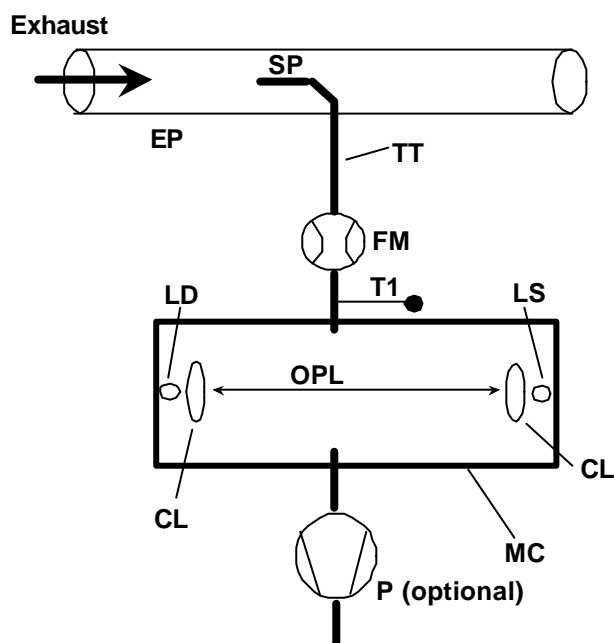

Figure 24 - Partial flow opacimeter

#### 3.3.1. Components of figure 24

**EP** Exhaust pipe

The exhaust pipe must be a straight pipe of at least 6 pipe diameters upstream and 3 pipe diameters downstream of the tip of the probe.

**SP** Sampling probe

The sampling probe must be an open tube facing upstream on or about the exhaust pipe centreline. The clearance with the wall of the tailpipe must be at least 5 mm. The probe diameter must ensure a representative sampling and a sufficient flow through the opacimeter.

**TT** Transfer tube

The transfer tube must:

- Be as short as possible and ensure an exhaust gas temperature of  $373 \pm 30$  K ( $100^{\circ}\text{C} \pm 30^{\circ}\text{C}$ ) at the entrance to the measuring chamber.
- Have a wall temperature sufficiently above the dew point of the exhaust gas to prevent condensation.
- Be equal to the diameter of the sampling probe over the entire length.
- Have a response time of less than 0.05 s at minimum instrument flow, as determined according to annex 4, appendix 4, paragraph 5.2.4.
- Have no significant effect on the smoke peak.

**FM** Flow measurement device

Flow instrumentation to detect the correct flow into the measuring chamber. The minimum and maximum flow rates must be specified by the instrument manufacturer, and must be such that the response time requirement of TT and the optical path length specifications are met. The flow measurement device may be close to the sampling pump, P, if used.

**MC** Measuring chamber

The measuring chamber must have a non-reflective internal surface, or equivalent optical environment. The impingement of stray light on the detector due to internal reflections of diffusion effects must be reduced to a minimum.

The pressure of the gas in the measuring chamber must not differ from the atmospheric pressure by more than 0.75 kPa. Where this is not possible by design, the opacimeter reading must be converted to atmospheric pressure.

The wall temperature of the measuring chamber must be set to within  $\pm 5$  K between 343 K ( $70^{\circ}\text{C}$ ) and 373 K ( $100^{\circ}\text{C}$ ), but in any case sufficiently above the dew point of the exhaust gas to prevent condensation. The measuring chamber must be equipped with appropriate devices for measuring the temperature.

**OPL** Optical path length

The length of the smoke obscured optical path between the opacimeter light source and the receiver, corrected as necessary for non-uniformity due to density gradients and fringe effect. The optical path length must be submitted by the instrument manufacturer taking into account any measures against sooting (e.g. purge air). If the optical path length is not available, it must be determined in accordance with ISO IDS 11614, paragraph 11.6.5.

**LS** Light source

The light source must be an incandescent lamp with a colour temperature in the range of 2800 to 3250 K or a green light emitting diode (LED) with a spectral peak between 550 and 570 nm. The light source must be protected against sooting by means that do not influence the optical path length beyond the manufacturers specifications.

**LD** Light detector

The detector must be a photocell or a photodiode (with a filter, if necessary). In the case of an incandescent light source, the receiver must have a peak spectral response similar to the photopic curve of the human eye (maximum response) in the range of 550 to 570 nm, to less than 4 per cent of that maximum response below 430 nm and above 680 nm. The light detector must be protected against sooting by means that do not influence the optical path length beyond the manufacturers specifications.

**CL** Collimating lens

The light output must be collimated to a beam with a maximum diameter of 30 mm. The rays of the light beam must be parallel within a tolerance of 3° of the optical axis.

**T1** Temperature sensor

To monitor the exhaust gas temperature at the entrance to the measuring chamber.

**P** Sampling pump (optional)

A sampling pump downstream of the measuring chamber may be used to transfer the sample gas through the measuring chamber.

Annex 5, amend to read:

"Annex 5

TECHNICAL CHARACTERISTICS OF REFERENCE FUEL FOR C.I. ENGINES  
PRESCRIBED FOR APPROVAL TESTS AND TO VERIFY CONFORMITY OF PRODUCTION

1. DIESEL FUEL <sup>(1)</sup>

Parameter	Unit	Limits <sup>(1)</sup>		Test Method <sup>(2)</sup>	Publication
		Minimum	Maximum		
Cetane number <sup>(3)</sup>		52	54	ISO 5165	1998 <sup>(4)</sup>
Density at 15 °C	kg/m <sup>3</sup>	833	837	ISO 3675	1995
Distillation :					
- 50 % point	°C	245		ISO 3405	1998
- 95 % point	°C	345	350	ISO 3405	1998
- final boiling point	°C	---	370	ISO 3405	1998
Flash point	°C	55	---	EN 27719	1993
CFPP	°C	---	-5	EN 116	1981
Viscosity at 40 °C	mm <sup>2</sup> /s	2.5	3.5	EN-ISO 3104	1996
Polycyclic aromatic hydrocarbons	% m/m	3.0	6.0	IP 391 <sup>(*)</sup>	1995
Sulphur content <sup>(5)</sup>	mg/kg	---	300	pr. EN-ISO/DIS 14596	1998 <sup>(4)</sup>
Copper corrosion		---	1	EN-ISO 2160	1995
Conradson carbon residue (10 % DR)	% m/m	---	0.2	EN-ISO 10370	
Ash content	% m/m	---	0.01	EN-ISO 6245	1995
Water content	% m/m	---	0.05	EN-ISO 12937	1995
Neutralisation (strong acid) number	mg OH/g	---	0.02	ASTM D 974-95	1998 <sup>(4)</sup>
Oxidation stability <sup>(6)</sup>	mg/ ml	---	0.025	EN-ISO 12205	1996

(1) If it is required to calculate the thermal efficiency of an engine or vehicle, the calorific value of the fuel can be calculated from:  
Specific energy (calorific value) (net) in MJ/kg = (46.423 - 8.792d<sup>2</sup> + 3.170d) (1 - (x + y + s)) + 9.420s - 2.499x

where:

d = the density at 15 °C  
x = the proportion by mass of water (% divided by 100)  
y = the proportion by mass of ash (% divided by 100)  
s = the proportion by mass of sulphur (% divided by 100).

(2) The values quoted in the specification are "true values". In establishment of their limit values the terms of ISO 4259, Petroleum products - Determination and application of precision data in relation to methods of test, have been applied and in fixing a minimum value, a minimum difference of 2R above zero has been taken

into account; in fixing a maximum and minimum value, the minimum difference is 4R (R - reproducibility). Notwithstanding this measure, which is necessary for statistical reasons, the manufacturer of a fuel should nevertheless aim at a zero value where the stipulated maximum value is 2R and at the mean value in the case of quotations of maximum and minimum limits. Should it be necessary to clarify the question as to whether a fuel meets the requirements of the specification, the terms of ISO 4259 should be applied.

- (3) The range for cetane number is not in accordance with the requirement of a minimum range of 4R. However, in the case of dispute between fuel supplier and fuel user, the terms in ISO 4259 can be used to resolve such disputes provided replicate measurements, of sufficient number to achieve the necessary precision, are made in preference to single determinations.
- (4) The month of publication will be completed in due course.
- (5) The actual sulphur content of the fuel used for the test must be reported. In addition, the sulphur content of the reference fuel used to approve a vehicle or engine against the limit values set out in row B of the Table in paragraph 5.2.1. of this Regulation must have a maximum sulphur content of 50 ppm.
- (6) Even though oxidation stability is controlled, it is likely that shelf life will be limited. Advice should be sought from the supplier as to storage conditions and life.

\_\_\_\_\_ "

Annex 6, amend to read:

"Annex 6

TECHNICAL CHARACTERISTICS OF REFERENCE N.G. FUEL PRESCRIBED FOR  
APPROVAL TESTS AND TO VERIFY CONFORMITY OF PRODUCTION

Type: NATURAL GAS (NG)

European market fuels are available in two ranges:

- the H range, whose extreme reference fuels are G<sub>20</sub> and G<sub>23</sub>;
- the L range, whose extreme reference fuels are G<sub>23</sub> and G<sub>25</sub>.

The characteristics of G<sub>20</sub>, G<sub>23</sub> and G<sub>25</sub> reference fuels are summarised below:

Reference fuel G<sub>20</sub>

Characteristics	Units	Basis	Limits		Test Method
			Min.	Max.	
<u>Composition:</u>					
Methane	%mole	100	99	100	ISO 6974
Balance [Inerts +C <sub>2</sub> /C <sub>2+</sub> ]		-	-	1	
N <sub>2</sub>					
Sulphur content	mg/m <sup>3</sup>	-	-	50	ISO 6326-5

Reference fuel G<sub>23</sub>

Characteristics	Units	Basis	Limits		Test Method
			Min.	Max.	
<u>Composition:</u>					
Methane	%mole	92.5	91.5	93.5	ISO 6974
Balance [Inerts +C <sub>2</sub> /C <sub>2+</sub> ]		-	-	1	
N <sub>2</sub>		7.5	6.5	8.5	
Sulphur content	mg/m <sup>3</sup> (*)	-	-	50	ISO 6326-5

(\*) value to be determined at standard conditions (293.2 K (20°C) and 101.3 kPa).



Reference fuel G<sub>25</sub>

Characteristics	Units	Basis	Limits		Test Method
			Min.	Max.	
<u>Composition:</u>					
Methane	%mole	86	84	88	ISO 6974
Balance [Inerts +C <sub>2</sub> /C <sub>2</sub> + ]		-	-	1	
N <sub>2</sub>		14	12	16	
Sulphur content	mg/m <sup>3</sup> (*)	-	-	50	ISO 6326-5

(\*) value to be determined at standard conditions (293.2 K (20°C) and 101.3 kPa).

\_\_\_\_\_ "

Insert new Annexes 7 and 8, to read:

"Annex 7

Type: LIQUEFIED PETROLEUM GAS (LPG)

Parameter	Unit	Limits Fuel A		Limits Fuel B		Test Method
		Minimum	Maximum	Minimum	Maximum	
Motor Octane Number		93.5		93.5		EN 589 Annex B
<u>Composition:</u>						
C3 content	% vol	48	52	83	87	
C4 content	% vol	48	52	13	17	ISO 7941
Olefins	% vol	0	12	9	15	
Evaporation Residue	mg/kg		50		50	NFM 41-015
Total sulphur content	ppm		50		50	EN 24260
Hydrogen sulphide	---		None		None	ISO 8819
Copper strip corrosion	rating		class 1		class 1	ISO 6251 <sup>(2)</sup>
Water at 0°C			free		free	visual inspection

(1) Value to be determined at standard conditions 293.2 K (20 °C) and 101.3 kPa

(2) This method may not accurately determine the presence of corrosive materials if the sample contains corrosion inhibitors or other chemicals, which diminish the corrosivity of the sample to the copper strip. Therefore, the addition of such compounds for the sole purpose of biasing the test method is prohibited.

\_\_\_\_\_

Annex 8

EXAMPLE OF CALCULATION PROCEDURE

1. ESC TEST

1.1. Gaseous emissions

The measurement data for the calculation of the individual mode results are shown below. In this example, CO and NO<sub>x</sub> are measured on a dry basis, HC on a wet basis.

The HC concentration is given in propane equivalent (C3) and has to be multiplied by 3 to result in the C1 equivalent.

The calculation procedure is identical for the other modes.

P (kW)	T <sub>a</sub> (K)	H <sub>a</sub> (g/kg)	G <sub>EXH</sub> (kg)	G <sub>AIRW</sub> (kg)	G <sub>FUEL</sub> (kg)	HC (ppm)	CO (ppm)	NO <sub>x</sub> (ppm)
82.9	294.8	7.81	563.38	545.29	18.09	6.3	41.2	495

Calculation of the dry to wet correction factor K<sub>w,r</sub> (annex 4, appendix 1, paragraph 4.2.):

$$F_{FH} = \frac{1,969}{\left(1 + \frac{18,09}{545,29}\right)} = 1.9058 \text{ and } K_{w2} = \frac{1,608 * 7,81}{1000 + (1,608 * 7,81)} = 0.0124$$

$$K_{w,r} = \left(1 - 1,9058 * \frac{18,09}{541,06}\right) - 0,0124 = 0,9239$$

Calculation of the wet concentrations:

$$\begin{aligned} \text{CO} &= 41.2 * 0.9239 = 38.1 \text{ ppm} \\ \text{NO}_x &= 495 * 0.9239 = 457 \text{ ppm} \end{aligned}$$

Calculation of the NO<sub>x</sub> humidity correction factor K<sub>H,D</sub> (annex 4, appendix 1, paragraph 4.3.):

$$\begin{aligned} A &= 0.309 * 18.09/541.06 - 0.0266 = -0.0163 \\ B &= -0.209 * 18.09/541.06 + 0.00954 = 0.0026 \end{aligned}$$

$$K_{H,D} = \frac{+}{1 - 0.0163 * (7.81 - 10.71) + 0.0026 * (294.8 - 298)} = 0.9625$$

Calculation of the emission mass flow rates (annex 4, appendix 1, paragraph 4.4.):

$$\begin{aligned} \text{NO}_x &= 0.001587 * 457 * 0.9625 * 563.38 = 393.27 \text{ g/h} \\ \text{CO} &= 0.000966 * 38.1 * 563.38 = 20.735 \text{ g/h} \\ \text{HC} &= 0.000479 * 6.3 * 3 * 563.38 = 5.100 \text{ g/h} \end{aligned}$$

Calculation of the specific emissions (annex 4, appendix 1, paragraph 4.5.):

The following example calculation is given for CO; the calculation procedure is identical for the other components.

The emission mass flow rates of the individual modes are multiplied by the respective weighting factors, as indicated in annex 4, appendix 1, paragraph 2.7.1., and summed up to result in the mean emission mass flow rate over the cycle:

$$\text{CO} = (6.7 * 0.15) + (24.6 * 0.08) + (20.5 * 0.10) + (20.7 * 0.10) + (20.6 * 0.05) + (15.0 * 0.05) + (19.7 * 0.05) + (74.5 * 0.09) + (31.5 * 0.10) + (81.9 * 0.08) + (34.8 * 0.05) + (30.8 * 0.05) + (27.3 * 0.05) = 30.91 \text{ g/h}$$

The engine power of the individual modes is multiplied by the respective weighting factors, as indicated in annex 4, appendix 1, paragraph 2.7.1., and summed up to result in the mean cycle power:

$$P(n) = (0.1 * 0.15) + (96.8 * 0.08) + (55.2 * 0.10) + (82.9 * 0.10) + (46.8 * 0.05) + (70.1 * 0.05) + (23.0 * 0.05) + (114.3 * 0.09) + (27.0 * 0.10) + (122.0 * 0.08) + (28.6 * 0.05) + (87.4 * 0.05) + (57.9 * 0.05) = 60.006 \text{ kW}$$

$$\overline{\text{CO}} = \frac{30,91}{60,006} = 0.515 \text{ g/kWh}$$

Calculation of the specific NO<sub>x</sub> emission of the random point (annex 4, appendix 1, paragraph 4.6.1.):

Assume the following values have been determined on the random point:

$$\begin{aligned} n_z &= 1600 \text{ min}^{-1} \\ M_z &= 495 \text{ Nm} \\ \text{NO}_{x, \text{mass}, z} &= 487.9 \text{ g/h (calculated according to the previous formulae)} \\ P(n)_z &= 83 \text{ kW} \\ \text{NO}_{x, z} &= 487.9/83 = 5.878 \text{ g/kWh} \end{aligned}$$

Determination of the emission value from the test cycle (annex 4, appendix 1, paragraph 4.6.2.):

Assume the values of the four enveloping modes on the ESC to be as follows:

n <sub>RT</sub>	n <sub>SU</sub>	E <sub>R</sub>	E <sub>S</sub>	E <sub>T</sub>	E <sub>U</sub>	M <sub>R</sub>	M <sub>S</sub>	M <sub>T</sub>	M <sub>U</sub>
1368	1785	5.943	5.565	5.889	4.973	515	460	681	610

$$E_{TU} = 5.889 + (4.973 - 5.889) * (1600 - 1368) / (1785 - 1368) = 5.377 \text{ g/kWh}$$

$$E_{RS} = 5.943 + (5.565 - 5.943) * (1600 - 1368) / (1785 - 1368) = 5.732 \text{ g/kWh}$$

$$M_{TU} = 681 + (601 - 681) * (1600 - 1368) / (1785 - 1368) = 641.3 \text{ Nm}$$

$$M_{RS} = 515 + (460-515) * (1600-1368)/(1785-1368) = 484.3 \text{ Nm}$$

$$E_z = 5.732 + (5.377-5.732) * (495-484.3)/(641.3-484.3) = 5.708 \text{ g/kWh}$$

Comparison of the NO<sub>x</sub> emission values (annex 4, appendix 1, paragraph 4.6.3.):

$$\text{NO}_x \text{ diff} = 100 * (5.878-5.708)/5.708 = 2.98 \%$$

## 1.2. Particulate Emissions

Particulate measurement is based on the principle of sampling the particulates over the complete cycle, but determining the sample and flow rates (MSAM and GEDF) during the individual modes. The calculation of GEDF depends on the system used. In the following examples, a system with CO<sub>2</sub> measurement and carbon balance method and a system with flow measurement are used. When using a full flow dilution system, GEDF is directly measured by the CVS equipment.

Calculation of GEDF (annex 4, appendix 1, paragraphs 5.2.3. and 5.2.4.):

Assume the following measurement data of mode 4. The calculation procedure is identical for the other modes.

G <sub>EXH</sub> (kg/h)	G <sub>FUEL</sub> (kg/h)	G <sub>DILW</sub> (kg/h)	G <sub>TOTW</sub> (kg/h)	CO <sub>2D</sub> (%)	CO <sub>2A</sub> (%)
334.02	10.76	5.4435	6.0	0.657	0.040

a) carbon balance method

$$G_{EDFW} = \frac{206,5 * 10,76}{0,657 - 0,040} = 3601.2 \text{ kg/h}$$

b) flow measurement method

$$q = \frac{6,0}{(6,0 - 5,4435)} = 10.78$$

$$G_{EDFW} = 334.02 * 10.78 = 3600.7 \text{ kg/h}$$

Calculation of the mass flow rate (annex 4, appendix 1, paragraph 5.4.):

The G<sub>EDFW</sub> flow rates of the individual modes are multiplied by the respective weighting factors, as indicated in annex 4, appendix 1, paragraph 2.7.1., and summed up to result in the mean G<sub>EDF</sub> over the cycle. The total sample rate M<sub>SAM</sub> is summed up from the sample rates of the individual modes.

$$\begin{aligned} \overline{G}_{EDFW} &= (3567 * 0.15) + (3592 * 0.08) + (3611 * 0.10) + (3600 * 0.10) \\ &+ (3618 * 0.05) + (3600 * 0.05) + (3640 * 0.05) + (3614 * 0.09) + (3620 * \\ &0.10) + (3601 * 0.08) + (3639 * 0.05) + (3582 * 0.05) + (3635 * 0.05) \\ &= 3604.6 \text{ kg/h} \end{aligned}$$

$$M_{SAM} = 0.226 + 0.122 + 0.151 + 0.152 + 0.076 + 0.076 + 0.076 + 0.136 + 0.151 + 0.121 + 0.076 + 0.076 + 0.075 = 1.515 \text{ kg}$$

Assume the particulate mass on the filters to be 2.5 mg, then

$$PT_{mass} = \frac{2,5}{1,515} * \frac{3604,6}{1000} = 5.948 \text{ g/h}$$

Background correction (optional)

Assume one background measurement with the following values. The calculation of the dilution factor DF is identical to paragraph 3.1. of this annex and not shown here.

$$M_d = 0.1 \text{ mg}; M_{DIL} = 1.5 \text{ kg}$$

$$\begin{aligned} \text{Sum of DF} &= [(1-1/119.15) * 0.15] + [(1-1/8.89) * 0.08] + [(1- \\ &1/14.75) * 0.10] + [(1-1/10.10) * 0.10] + [(1-1/18.02) * 0.05] \\ &+ [(1-1/12.33) * 0.05] + [(1-1/32.18) * 0.05] + [(1-1/6.94) * \\ &0.09] + [(1-1/25.19) * 0.10] + [(1-1/6.12) * 0.08] + [(1- \\ &1/20.87) * 0.05] + [(1-1/8.77) * 0.05] + [(1-1/12.59) * 0.05] \\ &= 0.923 \end{aligned}$$

$$PT_{mass} = \frac{2,5}{1,515} - \left( \frac{0,1}{1,5} * 0,923 \right) * \frac{3604,6}{1000} = 5.726 \text{ g/h}$$

Calculation of the specific emission (annex 4, appendix 1, paragraph 5.5.):

$$\begin{aligned} P(n) &= (0.1 * 0.15) + (96.8 * 0.08) + (55.2 * 0.10) + (82.9 * \\ &0.10) + (46.8 * 0.05) + (70.1 * 0.05) + (23.0 * 0.05) + (114.3 * \\ &0.09) + (27.0 * 0.10) + (122.0 * 0.08) + (28.6 * 0.05) + (87.4 * \\ &0.05) + (57.9 * 0.05) \end{aligned}$$

$$= 60.006 \text{ kW } \overline{PT} = \frac{5,948}{60,006} = 0.099 \text{ g/kWh, if background corrected}$$

$$\overline{PT} = \frac{5,726}{60,006} = 0.095 \text{ g/kWh}$$

Calculation of the specific weighting factor (annex 4, appendix 1, paragraph 5.6.):

Assume the values calculated for mode 4 above, then

$$WF_{E,I} = \frac{0,152 * 3604,6}{1,515 * 3600,7} = 0.1004$$

This value is within the required value of  $0.10 \pm 0.003$ .

2 ELR TEST

Since Bessel filtering is a completely new averaging procedure in European exhaust legislation, an explanation of the Bessel filter, an example of the design of a Bessel algorithm, and an example of the calculation of the final smoke value is given below. The constants of the Bessel algorithm only depend on the design of the opacimeter and the sampling rate of the data acquisition system. It is recommended that the opacimeter manufacturer provide the final Bessel filter constants for different sampling rates and that the customer use these constants for designing the Bessel algorithm and for calculating the smoke values.

2.1. General remarks on the Bessel filter

Due to high frequency distortions, the raw opacity signal usually shows a highly scattered trace. To remove these high frequency distortions a Bessel filter is required for the ELR-Test. The Bessel filter itself is a recursive, second-order low-pass filter which guarantees the fastest signal rise without overshoot.

Assuming a real time raw exhaust plume in the exhaust tube, each opacimeter shows a delayed and differently measured opacity trace. The delay and the magnitude of the measured opacity trace is primarily dependent on the geometry of the measuring chamber of the opacimeter, including the exhaust sample lines, and on the time needed for processing the signal in the electronics of the opacimeter. The values that characterise these two effects are called the physical and the electrical response time which represent an individual filter for each type of opacimeter. The goal of applying a Bessel filter is to guarantee a uniform overall filter characteristic of the whole opacimeter system, consisting of:

- physical response time of the opacimeter ( $t_p$ )
- electrical response time of the opacimeter ( $t_e$ )
- filter response time of the applied Bessel filter ( $t_F$ )

The resulting overall response time of the system  $t_{Aver}$  is given by:

$$t_{Aver} = \sqrt{t_F^2 + t_p^2 + t_e^2},$$

and must be equal for all kinds of opacimeters in order to give the same smoke value. Therefore, a Bessel filter has to be created in such a way, that the filter response time ( $t_F$ ) together with the physical ( $t_p$ ) and electrical response time ( $t_e$ ) of the individual opacimeter must result in the required overall response time ( $t_{Aver}$ ). Since  $t_p$  and  $t_e$  are given values for each individual opacimeter, and  $t_{Aver}$  is defined to be 1.0 s in this Regulation,  $t_F$  can be calculated as follows:

$$t_F = \sqrt{t_{Aver}^2 - t_p^2 - t_e^2}$$

By definition, the filter response time  $t_F$  is the rise time of a filtered output signal between 10 % and 90 % on a step input signal. Therefore the cut-off frequency of the Bessel filter has to be iterated in such a way, that the response time of the Bessel filter fits into the required rise time.

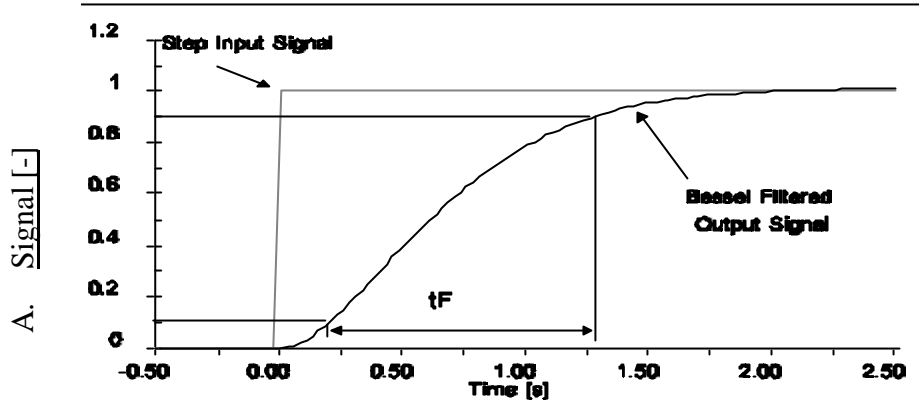
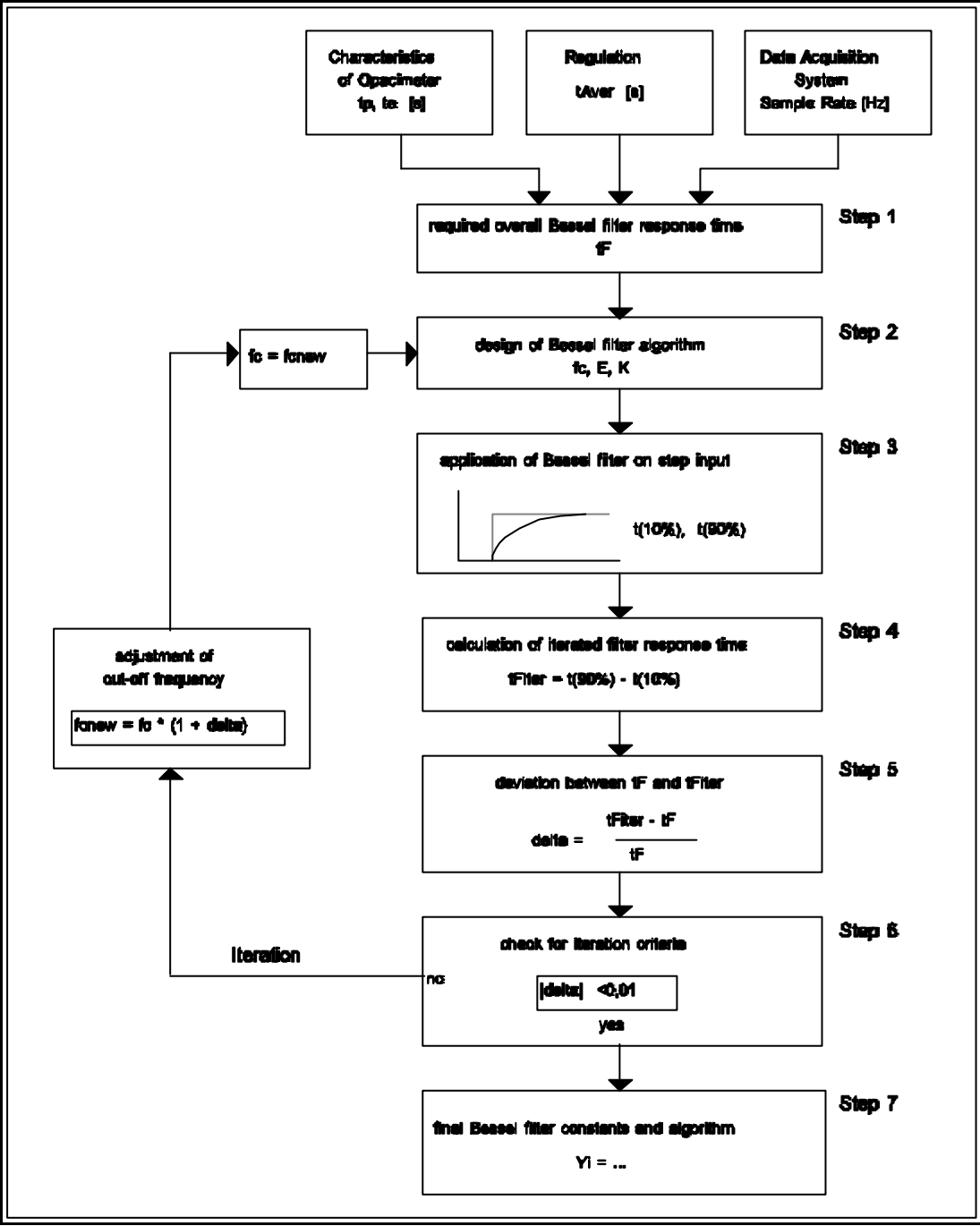

Figure (a) - Traces of a Step Input Signal and the Filtered Output Signal

In figure (a), the traces of a step input signal and Bessel filtered output signal as well as the response time of the Bessel filter ( $t_F$ ) are shown.

Designing the final Bessel filter algorithm is a multi step process which requires several iteration cycles. The scheme of the iteration procedure is presented below.





## 2.2. Calculation of the Bessel algorithm

In this example a Bessel algorithm is designed in several steps according to the above iteration procedure which is based upon annex 4, appendix 1, paragraph 6.1.

For the opacimeter and the data acquisition system, the following characteristics are assumed:

- physical response time  $t_p$       0.15 s
- electrical response time  $t_e$       0.05 s
- overall response time  $t_{Aver}$     1.00 s (by definition in this Regulation)
- sampling rate                      150 Hz

Step 1 Required Bessel filter response time  $t_F$ :

$$t_F = \sqrt{1^2 - (0,15^2 + 0,05^2)} = 0.987421 \text{ s}$$

Step 2 Estimation of cut-off frequency and calculation of Bessel constants E, K for first iteration:

$$f_c = 3.1415 / (10 * 0.987421) = 0.318152 \text{ Hz}$$

$$\Delta t = 1 / 150 = 0.006667 \text{ s}$$

$$\tilde{U} = 1 / [\tan (3.1415 * 0.006667 * 0.318152)] = 150.076644$$

$$E = \frac{1}{1 + 150,076644 * \sqrt{3 * 0,618034} + 0,618034 * 150,076644^2} = 7.07948 \text{ E-5}$$

$$K = 2 * 7.07948 \text{ E-5} * (0.618034 * 150.076644 - 1) - 1 = 0.970783$$

This gives the Bessel algorithm:

$$Y_i = Y_{i-1} + 7.07948 \text{ E-5} * (S_i + 2 * S_{i-1} + S_{i-2} - 4 * Y_{i-2}) + 0.970783 * (Y_{i-1} - Y_{i-2})$$

where  $S_i$  represents the values of the step input signal (either '0' or '1') and  $Y_i$  represents the filtered values of the output signal.

Step 3 Application of Bessel filter on step input:

The Bessel filter response time  $t_F$  is defined as the rise time of the filtered output signal between 10 % and 90 % on a step input signal. For determining the times of 10 % ( $t_{10}$ ) and 90 % ( $t_{90}$ ) of the output signal, a Bessel filter has to be applied to a step input using the above values of  $f_c$ , E and K.

The index numbers, the time and the values of a step input signal and the resulting values of the filtered output signal for the first and the second iteration are shown in table B. The points adjacent to  $t_{10}$  and  $t_{90}$  are marked in bold numbers.

In table B, first iteration, the 10 % value occurs between index number 30 and 31 and the 90 % value occurs between index number 191 and 192. For the calculation of  $t_{F,iter}$  the exact  $t_{10}$  and  $t_{90}$  values are determined by linear interpolation between the adjacent measuring points, as follows:

$$t_{10} = t_{lower} + \ddot{A}t * (0.1 - out_{lower}) / (out_{upper} - out_{lower})$$

$$t_{90} = t_{lower} + \ddot{A}t * (0.9 - out_{lower}) / (out_{upper} - out_{lower})$$

where  $out_{upper}$  and  $out_{lower}$ , respectively, are the adjacent points of the Bessel filtered output signal, and  $t_{lower}$  is the time of the adjacent time point, as indicated in table B.

$$t_{10} = 0.200000 + 0.006667 * (0.1 - 0.099208) / (0.104794 - 0.099208) = 0.200945 \text{ s}$$

$$t_{90} = 1.273333 + 0.006667 * (0.9 - 0.899147) / (0.901168 - 0.899147) = 1.276147 \text{ s}$$

Step 4 Filter response time of first iteration cycle:

$$t_{F,iter} = 1.276147 - 0.200945 = 1.075202 \text{ s}$$

Step 5 Deviation between required and obtained filter response time of first iteration cycle:

$$\ddot{A} = (1.075202 - 0.987421) / 0.987421 = 0.081641$$

Step 6 Checking the iteration criteria:

$|\ddot{A}|$  0.01 is required. Since  $0.081641 > 0.01$ , the iteration criteria is not met and a further iteration cycle has to be started. For this iteration cycle, a new cut-off frequency is calculated from  $f_c$  and  $\ddot{A}$  as follows:

$$f_{c,new} = 0.318152 * (1 + 0.081641) = 0.344126 \text{ Hz}$$

This new cut-off frequency is used in the second iteration cycle, starting at step 2 again. The iteration has to be repeated until the iteration criteria is met. The resulting values of the first and second iteration are summarised in table A.

Parameter	1. Iteration	2. Iteration
$f_c$ (Hz)	0.318152	0.344126
E (-)	7.07948 E-5	8.272777 E-5
K (-)	0.970783	0.968410
$t_{10}$ (s)	0.200945	0.185523
$t_{90}$ (s)	1.276147	1.179562
$t_{F,iter}$ (s)	1.075202	0.994039
$\ddot{A}$ (-)	0.081641	0.006657
$f_{c,new}$ (Hz)	0.344126	0.346417

Table A - Values of the first and second iteration

## Step 7 Final Bessel algorithm:

As soon as the iteration criteria has been met, the final Bessel filter constants and the final Bessel algorithm are calculated according to step 2. In this example, the iteration criteria has been met after the second iteration ( $\Delta = 0.006657 \quad 0.01$ ). The final algorithm is then used for determining the averaged smoke values (see next paragraph 2.3).

$$Y_i = Y_{i-1} + 8.272777E-5 * (S_i + 2 * S_{i-1} + S_{i-2} - 4 * Y_{i-2}) + 0.968410 * (Y_{i-1} - Y_{i-2})$$

Index i [-]	Time [s]	Step Input Signal S <sub>i</sub> [-]	Filtered Output Signal Y <sub>i</sub> [-]	
			1. Iteration	2. Iteration
-2	-0.013333	0	0.000000	0.000000
-1	-0.006667	0	0.000000	0.000000
0	0.000000	1	0.000071	0.000083
1	0.006667	1	0.000352	0.000411
2	0.013333	1	0.000908	0.001060
3	0.020000	1	0.001731	0.002019
4	0.026667	1	0.002813	0.003278
5	0.033333	1	0.004145	0.004828
~	~	~	~	~
24	0.160000	1	0.067877	0.077876
25	0.166667	1	0.072816	0.083476
26	0.173333	1	0.077874	0.089205
27	0.180000	1	0.083047	0.095056
28	0.186667	1	0.088331	0.101024
29	0.193333	1	0.093719	0.107102
30	0.200000	1	0.099208	0.113286
31	0.206667	1	0.104794	0.119570
32	0.213333	1	0.110471	0.125949
33	0.220000	1	0.116236	0.132418
34	0.226667	1	0.122085	0.138972
35	0.233333	1	0.128013	0.145605
36	0.240000	1	0.134016	0.152314
37	0.246667	1	0.140091	0.159094
~	~	~	~	~
175	1.166667	1	0.862416	0.895701
176	1.173333	1	0.864968	0.897941
177	1.180000	1	0.867484	0.900145
178	1.186667	1	0.869964	0.902312
179	1.193333	1	0.872410	0.904445
180	1.200000	1	0.874821	0.906542
181	1.206667	1	0.877197	0.908605
182	1.213333	1	0.879540	0.910633
183	1.220000	1	0.881849	0.912628
184	1.226667	1	0.884125	0.914589
185	1.233333	1	0.886367	0.916517
186	1.240000	1	0.888577	0.918412
187	1.246667	1	0.890755	0.920276
188	1.253333	1	0.892900	0.922107
189	1.260000	1	0.895014	0.923907
190	1.266667	1	0.897096	0.925676
191	1.273333	1	0.899147	0.927414
192	1.280000	1	0.901168	0.929121
193	1.286667	1	0.903158	0.930799
194	1.293333	1	0.905117	0.932448
195	1.300000	1	0.907047	0.934067
~	~	~	~	~

Table B - Values of step input signal and Bessel filtered output signal for the first and second iteration cycle

2.3. Calculation of the Smoke Values

In the scheme below the general procedure of determining the final smoke value is presented.

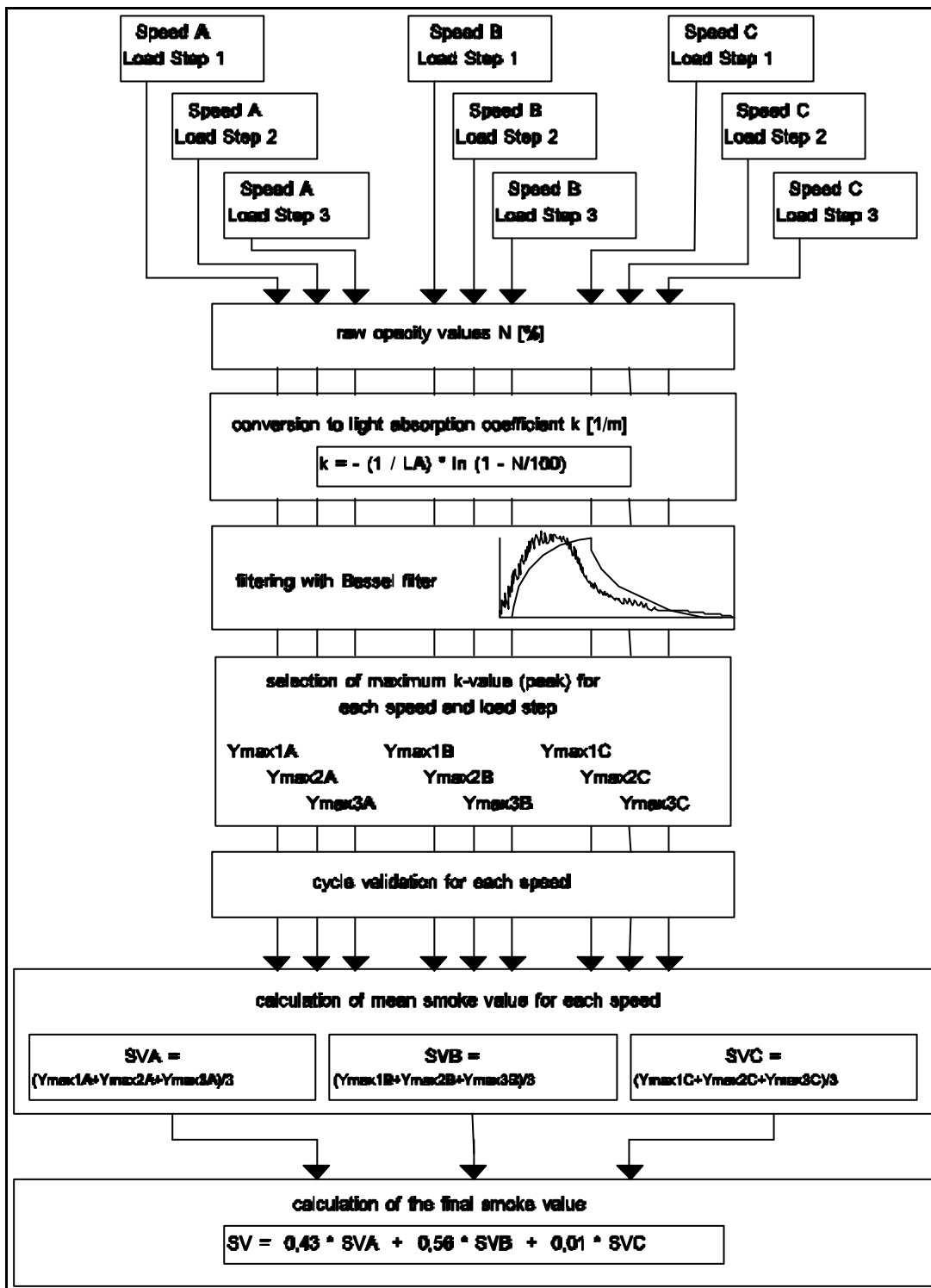

In figure b, the traces of the measured raw opacity signal, and of the unfiltered and filtered light absorption coefficients (k-value) of the first load step of an ELR-Test are shown, and the maximum value  $Y_{\max 1, A}$  (peak) of the filtered k trace is indicated. Correspondingly, table C contains the numerical values of index i, time (sampling rate of 150 Hz), raw opacity, unfiltered k and filtered k. Filtering was conducted using the constants of the Bessel algorithm designed in paragraph 2.2. of this annex. Due to the large amount of data, only those sections of the smoke trace around the beginning and the peak are tabled.

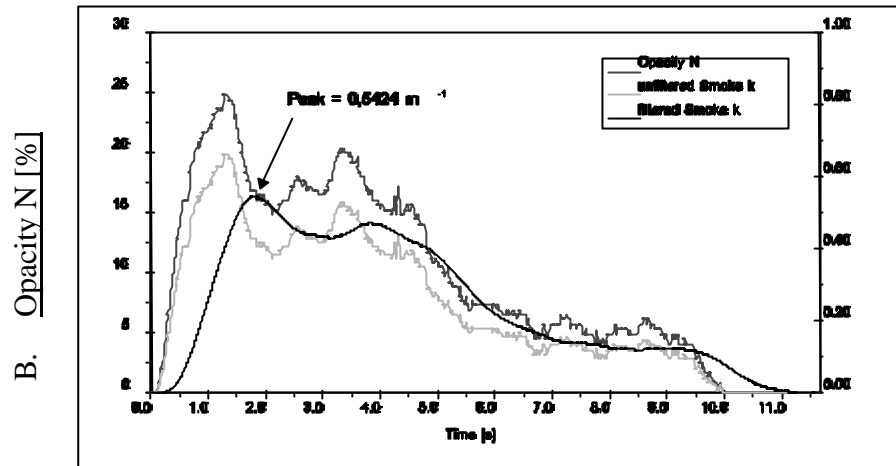

Figure b - Traces of measured opacity N, of unfiltered smoke k and of filtered smoke k

The peak value ( $i = 272$ ) is calculated assuming the following data of table C. All other individual smoke

Calculation of the k-value (annex 4, appendix 1, paragraph 6.3.1.):

$L_A$ (m)	0.430
Index I	272
N (%)	16.783
$S_{271}$ ( $m^{-1}$ )	0.427392
$S_{270}$ ( $m^{-1}$ )	0.427532
$Y_{271}$ ( $m^{-1}$ )	0.542383
$Y_{270}$ ( $m^{-1}$ )	0.542337

$$k = -\frac{1}{0,430} * \ln\left(1 - \frac{16,783}{100}\right) = 0.427252 \text{ m}^{-1}$$

This value corresponds to  $S_{272}$  in the equation that follows.

Calculation of Bessel averaged smoke (annex 4, appendix 1, paragraph 6.3.2.):

In the following equation, the Bessel constants of the previous paragraph 2.2. are used. The actual unfiltered k-value, as calculated above, corresponds to  $S_{272}$  ( $S_i$ ).  $S_{271}$  ( $S_{i-1}$ ) and  $S_{270}$  ( $S_{i-2}$ ) are the two preceding unfiltered k-values,  $Y_{271}$  ( $Y_{i-1}$ ) and  $Y_{270}$  ( $Y_{i-2}$ ) are the two preceding filtered k-values.

$$Y_{272} = 0.542383 + 8.272777E-5 * (0.427252 + 2 * 0.427392 + 0.427532 - 4 * 0.542337) + 0.968410 * (0.542383 - 0.542337) = 0.542389 \text{ m}^{-1}$$

This value corresponds to  $Y_{\max 1, A}$  in the following equation.

Calculation of the final smoke value (annex 4, appendix 1, paragraph 6.3.3.):

From each smoke trace, the maximum filtered k-value is taken for the further calculation. Assume the following values:

Speed	$Y_{\max} \text{ (m}^{-1}\text{)}$		
	Cycle 1	Cycle 2	Cycle 3
A	0.5424	0.5435	0.5587
B	0.5596	0.5400	0.5389
C	0.4912	0.5207	0.5177

$$SV_A = (0.5424 + 0.5435 + 0.5587) / 3 = 0.5482 \text{ m}^{-1}$$

$$SV_B = (0.5596 + 0.5400 + 0.5389) / 3 = 0.5462 \text{ m}^{-1}$$

$$SV_C = (0.4912 + 0.5207 + 0.5177) / 3 = 0.5099 \text{ m}^{-1}$$

$$SV = (0.43 * 0.5482) + (0.56 * 0.5462) + (0.01 * 0.5099) = 0.5467 \text{ m}^{-1}$$

Cycle validation (annex 4, appendix 1, paragraph 3.4.)

Before calculating SV, the cycle must be validated by calculating the relative standard deviations of the smoke of the three cycles for each speed.

Speed	Mean SV ( $\text{m}^{-1}$ )	absolute standard deviation ( $\text{m}^{-1}$ )	relative standard deviation (%)
A	0.5482	0.0091	1.7
B	0.5462	0.0116	2.1
C	0.5099	0.0162	3.2

In this example, the validation criteria of 15 per cent is met for each speed.



Table C

Values of opacity N, unfiltered and filtered k-value at beginning of load step

Index I [-]	Time [s]	Opacity N [%]	unfiltered k-Value [m <sup>-1</sup> ]	filtered k-Value [m <sup>-1</sup> ]
-2	0.000000	0.000000	0.000000	0.000000
-1	0.000000	0.000000	0.000000	0.000000
0	0.000000	0.000000	0.000000	0.000000
1	0.006667	0.020000	0.000465	0.000000
2	0.013333	0.020000	0.000465	0.000000
3	0.020000	0.020000	0.000465	0.000000
4	0.026667	0.020000	0.000465	0.000001
5	0.033333	0.020000	0.000465	0.000002
6	0.040000	0.020000	0.000465	0.000002
7	0.046667	0.020000	0.000465	0.000003
8	0.053333	0.020000	0.000465	0.000004
9	0.060000	0.020000	0.000465	0.000005
10	0.066667	0.020000	0.000465	0.000006
11	0.073333	0.020000	0.000465	0.000008
12	0.080000	0.020000	0.000465	0.000009
13	0.086667	0.020000	0.000465	0.000011
14	0.093333	0.020000	0.000465	0.000012
15	0.100000	0.192000	0.004469	0.000014
16	0.106667	0.212000	0.004935	0.000018
17	0.113333	0.212000	0.004935	0.000022
18	0.120000	0.212000	0.004935	0.000028
19	0.126667	0.343000	0.007990	0.000036
20	0.133333	0.566000	0.013200	0.000047
21	0.140000	0.889000	0.020767	0.000061
22	0.146667	0.929000	0.021706	0.000082
23	0.153333	0.929000	0.021706	0.000109
24	0.160000	1.263000	0.029559	0.000143
25	0.166667	1.455000	0.034086	0.000185
26	0.173333	1.697000	0.039804	0.000237
27	0.180000	2.030000	0.047695	0.000301
28	0.186667	2.081000	0.048906	0.000378
29	0.193333	2.081000	0.048906	0.000469
30	0.200000	2.424000	0.057067	0.000573
31	0.206667	2.475000	0.058282	0.000693
32	0.213333	2.475000	0.058282	0.000827
33	0.220000	2.808000	0.066237	0.000977
34	0.226667	3.010000	0.071075	0.001144
35	0.233333	3.253000	0.076909	0.001328
36	0.240000	3.606000	0.085410	0.001533
37	0.246667	3.960000	0.093966	0.001758
38	0.253333	4.455000	0.105983	0.002007
39	0.260000	4.818000	0.114836	0.002283
40	0.266667	5.020000	0.119776	0.002587
~	~	~	~	~

Table C (continued)

Values of opacity N, unfiltered and filtered k-value around  $Y_{\max 1,A}$   
(= peak value, indicated in bold number)

Index i [-]	Time [s]	Opacity N [%]	unfiltered k-Value [m <sup>-1</sup> ]	filtered k-Value [m <sup>-1</sup> ]
~	~	~	~	~
259	1.726667	17.182000	0.438429	0.538856
260	1.733333	16.949000	0.431896	0.539423
261	1.740000	16.788000	0.427392	0.539936
262	1.746667	16.798000	0.427671	0.540396
263	1.753333	16.788000	0.427392	0.540805
264	1.760000	16.798000	0.427671	0.541163
265	1.766667	16.798000	0.427671	0.541473
266	1.773333	16.788000	0.427392	0.541735
267	1.780000	16.788000	0.427392	0.541951
268	1.786667	16.798000	0.427671	0.542123
269	1.793333	16.798000	0.427671	0.542251
270	1.800000	16.793000	0.427532	0.542337
271	1.806667	16.788000	0.427392	0.542383
272	1.813333	16.783000	0.427252	0.542389
273	1.820000	16.780000	0.427168	0.542357
274	1.826667	16.798000	0.427671	0.542288
275	1.833333	16.778000	0.427112	0.542183
276	1.840000	16.808000	0.427951	0.542043
277	1.846667	16.768000	0.426833	0.541870
278	1.853333	16.010000	0.405750	0.541662
279	1.860000	16.010000	0.405750	0.541418
280	1.866667	16.000000	0.405473	0.541136
281	1.873333	16.010000	0.405750	0.540819
282	1.880000	16.000000	0.405473	0.540466
283	1.886667	16.010000	0.405750	0.540080
284	1.893333	16.394000	0.416406	0.539663
285	1.900000	16.394000	0.416406	0.539216
286	1.906667	16.404000	0.416685	0.538744
287	1.913333	16.394000	0.416406	0.538245
288	1.920000	16.394000	0.416406	0.537722
289	1.926667	16.384000	0.416128	0.537175
290	1.933333	16.010000	0.405750	0.536604
291	1.940000	16.010000	0.405750	0.536009
292	1.946667	16.000000	0.405473	0.535389
293	1.953333	16.010000	0.405750	0.534745
294	1.960000	16.212000	0.411349	0.534079
295	1.966667	16.394000	0.416406	0.533394
296	1.973333	16.394000	0.416406	0.532691
297	1.980000	16.192000	0.410794	0.531971
298	1.986667	16.000000	0.405473	0.531233
299	1.993333	16.000000	0.405473	0.530477
300	2.000000	16.000000	0.405473	0.529704
~	~	~	~	~

## 3. ETC TEST

3.1. Gaseous emissions (Diesel engine)

Assume the following test results for a PDP-CVS system

$V_0$	(m <sup>3</sup> /rev)	0.1776
$N_p$	(rev)	23073
$P_B$	(kPa)	98.0
$P_1$	(kPa)	2.3
T	(K)	322.5
$H_a$	(g/kg)	12.8
$NO_x$ conce	(ppm)	53.7
$NO_x$ concd	(ppm)	0.4
CO conce	(ppm)	38.9
CO concd	(ppm)	1.0
HC conce	(ppm)	9.00
HC concd	(ppm)	3.02
$CO_2$ , conce	(%)	0.723
$W_{act}$	(kWh)	62.72

Calculation of the diluted exhaust gas flow (annex 4, appendix 2, paragraph 4.1.):

$$M_{TOTW} = 1.293 * 0.1776 * 23073 * (98.0 - 2.3) * 273 / (101.3 * 322.5) \\ = 4237.2 \text{ kg}$$

Calculation of the  $NO_x$  correction factor (annex 4, appendix 2, paragraph 4.2.):

$$K_{H,D} = \frac{1}{1 - 0,0182 * (12,8 - 10,71)} = 1.039$$

Calculation of the background corrected concentrations (annex 4, appendix 2, paragraph 4.3.1.1.):

Assuming a diesel fuel of the composition  $C_{12}H_{18}$

$$F_S = 100 * \frac{1}{1 + (1,8/2) + (3,76 * (1 + (1,8/4)))} = 13.6$$

$$DF = \frac{13,6}{0,723 + (9,00 + 38,9) * 10^{-4}} = 18.69$$

$$NO_{x \text{ conc}} = 53.7 - 0.4 * (1 - (1/18.69)) = 53.3 \text{ ppm}$$

$$CO_{\text{conc}} = 38.9 - 1.0 * (1 - (1/18.69)) = 37.9 \text{ ppm}$$

$$HC_{\text{conc}} = 9.00 - 3.02 * (1 - (1/18.69)) = 6.14 \text{ ppm}$$

Calculation of the emissions mass flow (annex 4, appendix 2, paragraph 4.3.1.):

$$NO_{x \text{ mass}} = 0.001587 * 53.3 * 1.039 * 4237.2 = 372.391 \text{ g}$$

$$\begin{aligned} \text{CO}_{\text{mass}} &= 0.000966 * 37.9 * 4237.2 = 155.129 \text{ g} \\ \text{HC}_{\text{mass}} &= 0.000479 * 6.14 * 4237.2 = 12.462 \text{ g} \end{aligned}$$

Calculation of the specific emissions (annex 4, appendix 2, paragraph 4.4.):

$$\begin{aligned} \overline{\text{NO}}_{x1} &= 372.391 / 62.72 = 5.94 \text{ g/kWh} \\ \overline{\text{CO}}_2 &= 155.129 / 62.72 = 2.47 \text{ g/kWh} \\ \overline{\text{HC}}_3 &= 12.462 / 62.72 = 0.199 \text{ g/kWh} \end{aligned}$$

### 3.2. Particulate Emissions (Diesel Engine)

Assume the following test results for a PDP-CVS system with double dilution

$M_{\text{TOTW}}$ (kg)	4237.2
$M_{\text{f,p}}$ (mg)	3.030
$M_{\text{f,b}}$ (mg)	0.044
$M_{\text{TOT}}$ (kg)	2.159
$M_{\text{SEC}}$ (kg)	0.909
$M_{\text{d}}$ (mg)	0.341
$M_{\text{DIL}}$ (kg)	1.245
DF	18.69
$W_{\text{act}}$ (kWh)	62.72

Calculation of the mass emission (annex 4, appendix 2, paragraph 5.1.):

$$M_{\text{f}} = 3.030 + 0.044 = 3.074 \text{ mg}$$

$$M_{\text{SAM}} = 2.159 - 0.909 = 1.250 \text{ kg}$$

$$PT_{\text{mass}} = \frac{3.074}{1.250} * \frac{4237.2}{1000} = 10.42 \text{ g}$$

Calculation of the background corrected mass emission (annex 4, appendix 2, paragraph 5.1.):

$$PT_{\text{mass}} = \left[ \frac{3,074}{1,250} - \left( \frac{0,341}{1,245} * \left( 1 - \frac{1}{18,69} \right) \right) \right] * \frac{4237,2}{1000} = 9.32 \text{ g}$$

Calculation of the specific emission (annex 4, appendix 2, paragraph 5.2):

$$\begin{aligned} \overline{\text{NO}}_x &= 372.391 / 62.72 = 5.94 \text{ g/kWh} \\ \overline{\text{CO}} &= 155.129 / 62.72 = 2.47 \text{ g/kWh} \\ \overline{\text{HC}} &= 12.462 / 62.72 = 0.199 \text{ g/kWh} \end{aligned}$$

3.3. Gaseous emissions (CNG engine)

Assume the following test results for a PDP-CVS system with double dilution

$M_{TOTW}$	(kg)	4237.2
$H_a$	(g/kg)	12.8
$NO_x$ conce	(ppm)	17.2
$NO_x$ concd	(ppm)	0.4
$CO$ conce	(ppm)	44.3
$CO$ concd	(ppm)	1.0
$HC$ conce	(ppm)	27.0
$HC$ concd	(ppm)	3.02
$CH_4$ conce	(ppm)	18.0
$CH_4$ concd	(ppm)	1.7
$CO_2$ , conce	(%)	0.723
$W_{act}$	(kWh)	62.72

Calculation of the NOx correction factor (annex 4, appendix 2, paragraph 4.2.):

$$K_{H,G} = \frac{1}{1 - 0.0329 * (12.8 - 10.71)} = 1.074$$

Calculation of the NMHC concentration (annex 4, appendix 2, paragraph 4.3.1.):

a) GC method

$$NMHC_{conce} = 27.0 - 18.0 = 9.0 \text{ ppm}$$

b) NMC method

Assuming a methane efficiency of 0.04 and an ethane efficiency of 0.98 (see annex 4, appendix 5, paragraph 1.8.4.)

$$NMHC_{conce} = \frac{27.0 * (1 - 0.04) - 18.0}{0.98 - 0.04} = 8.4 \text{ ppm}$$

Calculation of the background corrected concentrations (annex 4, appendix 2, paragraph 4.3.1.1.):

Assuming a G20 reference fuel (100 % methane) of the composition  $C_1H_4$

$$F_s = 100 * \frac{1}{1 + (4/2) + (3.78 * (1 + (4/4)))} = 9.5$$

$$DF = \frac{9.5}{0.723 + (27.0 + 44.3) * 10^{-4}} = 13.01$$

For NMHC, the background concentration is the difference between HC<sub>concd</sub> and CH<sub>4</sub> <sub>concd</sub>

$$\begin{aligned} \text{NO}_x \text{ conc} &= 17.2 - 0.4 * (1 - (1/13.01)) = 16.8 \text{ ppm} \\ \text{CO}_{\text{concd}} &= 44.3 - 1.0 * (1 - (1/13.01)) = 43.4 \text{ ppm} \\ \text{NMHC}_{\text{concd}} &= 8.4 - 1.32 * (1 - (1/13.01)) = 7.2 \text{ ppm} \\ \text{CH}_4 \text{ conc} &= 18.0 - 1.7 * (1 - (1/13.01)) = 16.4 \text{ ppm} \end{aligned}$$

Calculation of the emissions mass flow (annex 4, appendix 2, paragraph 4.3.1.):

$$\begin{aligned} \text{NO}_x \text{ mass} &= 0.001587 * 16.8 * 1.074 * 4237.2 = 121.330 \text{ g} \\ \text{CO}_{\text{mass}} &= 0.000966 * 43.4 * 4237.2 = 177.642 \text{ g} \\ \text{NMHC}_{\text{mass}} &= 0.000502 * 7.2 * 4237.2 = 15.315 \text{ g} \\ \text{CH}_4 \text{ mass} &= 0.000554 * 16.4 * 4237.2 = 38.498 \text{ g} \end{aligned}$$

Calculation of the specific emissions (annex 4, appendix 2, paragraph 4.4.):

$$\begin{aligned} \overline{\text{NO}_x} &= 121.330/62.72 = 1.93 \text{ g/kWh} \\ \overline{\text{CO}} &= 177.642/62.72 = 2.83 \text{ g/kWh} \\ \overline{\text{NMHC}} &= 15.315/62.72 = 0.244 \text{ g/kWh} \\ \overline{\text{CH}_4} &= 38.498/62.72 = 0.614 \text{ g/kWh} \end{aligned}$$

4.  $\ddot{e}$ -SHIFT FACTOR ( $S_{\ddot{e}}$ )

4.1. Calculation of the  $\ddot{e}$ -shift factor ( $S_{\ddot{e}}$ ) <sup>(2)</sup>

$$SI = \frac{2}{\left(1 - \frac{\text{inert \%}}{100}\right) \left(n + \frac{m}{4}\right) - \frac{O_2^*}{100}}$$

where:

$S_{\ddot{e}}$  =  $\ddot{e}$ -shift factor;  
inert % = % by volume of inert gases in the fuel (i.e. N<sub>2</sub>, CO<sub>2</sub>, He, etc.);  
O<sub>2</sub>\* = % by volume of original oxygen in the fuel;  
n and m = refer to average C<sub>n</sub>H<sub>m</sub> representing the fuel hydrocarbons, i.e.:

$$n = \frac{1 * \left[\frac{\text{CH}_4 \%}{100}\right] + 2 * \left[\frac{\text{C}_2 \%}{100}\right] + 3 * \left[\frac{\text{C}_3 \%}{100}\right] + 4 * \left[\frac{\text{C}_4 \%}{100}\right] + 5 * \left[\frac{\text{C}_5 \%}{100}\right] + \dots}{1 - \frac{\text{diluent \%}}{100}}$$

<sup>(2)</sup> Stoichiometric Air/Fuel ratios of automotive fuels SAE J1829, June 1987. John B. Heywood, Internal Combustion Engine Fundamentals, McGraw-Hill, 1988, Chapter 3.4. Combustion stoichiometry (pages 68 72).

$$m = \frac{4 * \left[ \frac{CH_4 \%}{100} \right] + 4 * \left[ \frac{C_2H_4 \%}{100} \right] + 6 * \left[ \frac{C_2H_6 \%}{100} \right] + 8 * \left[ \frac{C_3H_8 \%}{100} \right] + \dots}{1 - \frac{diluent \%}{100}}$$

where:

CH<sub>4</sub> = % by volume of methane in the fuel;

C<sub>2</sub> = % by volume of all C<sub>2</sub> hydrocarbons (e.g.: C<sub>2</sub>H<sub>6</sub>, C<sub>2</sub>H<sub>4</sub>, etc.) in the fuel;

C<sub>3</sub> = % by volume of all C<sub>3</sub> hydrocarbons (e.g.: C<sub>3</sub>H<sub>8</sub>, C<sub>3</sub>H<sub>6</sub>, etc.) in the fuel;

C<sub>4</sub> = % by volume of all C<sub>4</sub> hydrocarbons (e.g.: C<sub>4</sub>H<sub>10</sub>, C<sub>4</sub>H<sub>8</sub>, etc.) in the fuel;

C<sub>5</sub> = % by volume of all C<sub>5</sub> hydrocarbons (e.g.: C<sub>5</sub>H<sub>12</sub>, C<sub>5</sub>H<sub>10</sub>, etc.) in the fuel;

diluent = % by volume of dilution gases in the fuel (i.e.: O<sub>2</sub>\*, N<sub>2</sub>, CO<sub>2</sub>, He, etc.).

#### 4.2. Examples for the calculation of the $\bar{e}$ -shift factor $S_{\bar{e}}$ :

Example 1: G<sub>25</sub>: CH<sub>4</sub> = 86%, N<sub>2</sub> = 14% (by vol)

$$n = \frac{1 * \left[ \frac{CH_4 \%}{100} \right] + 2 * \left[ \frac{C_2 \%}{100} \right] + \dots}{1 - \frac{diluent \%}{100}} = \frac{1 * 0.86}{1 - \frac{14}{100}} = \frac{0.86}{0.86} = 1$$

$$m = \frac{4 * \left[ \frac{CH_4 \%}{100} \right] + 4 * \left[ \frac{C_2H_4 \%}{100} \right] + \dots}{1 - \frac{diluent \%}{100}} = \frac{4 * 0.86}{0.86} = 4$$

$$SI = \frac{2}{\left( 1 - \frac{inert \%}{100} \right) \left( n + \frac{m}{4} \right) - \frac{O_2 *}{100}} = \frac{2}{\left( 1 - \frac{14}{100} \right) x \left( 1 + \frac{4}{4} \right)} = 1.16$$

Example 2:  $G_{xy}$ :  $CH_4 = 87 \%$ ,  $C_2H_6 = 13 \%$  (by vol)

$$n = \frac{1 * \left[ \frac{CH_4 \%}{100} \right] + 2 * \left[ \frac{C_2 \%}{100} \right] + \dots}{1 - \frac{\text{diluent \%}}{100}} = \frac{1 * 0,87 + 2 * 0,13}{1 - \frac{0}{100}} = \frac{1,13}{1} = 1,13$$

$$m = \frac{4 * \left[ \frac{CH_4 \%}{100} \right] + 6 * \left[ \frac{C_2H_6 \%}{100} \right] + \dots}{1 - \frac{\text{diluent \%}}{100}} = \frac{4 * 0,87 + 6 * 0,13}{1} = 4,26$$

$$SI = \frac{2}{\left( 1 - \frac{\text{inert \%}}{100} \right) \left( n + \frac{m}{4} \right) - \frac{O_2 *}{100}} = \frac{2}{\left( 1 - \frac{0}{100} \right) * \left( 1,13 + \frac{4,26}{4} \right)} = 0,911$$

Example 3: USA:  $CH_4 = 89 \%$ ,  $C_2H_6 = 4.5 \%$ ,  $C_3H_8 = 2.3 \%$ ,  $C_6H_{14} = 0.2 \%$ ,  
 $O_2 = 0.6 \%$ ,  $N_2 = 4 \%$

$$n = \frac{1 * \left[ \frac{CH_4 \%}{100} \right] + 2 * \left[ \frac{C_2 \%}{100} \right] + \dots}{1 - \frac{\text{diluent \%}}{100}} = \frac{1 * 0,89 + 2 * 0,045 + 3 * 0,023 + 4 * 0,002}{1 - \frac{(0,64 + 4)}{100}} = 1,11$$

$$m = \frac{4 * \left[ \frac{CH_4 \%}{100} \right] + 4 * \left[ \frac{C_2H_4 \%}{100} \right] + 6 * \left[ \frac{C_2H_6 \%}{100} \right] + \dots + 8 * \left[ \frac{C_3H_8 \%}{100} \right]}{1 - \frac{\text{diluent \%}}{100}} =$$

$$= \frac{4 * 0,89 + 4 * 0,045 + 8 * 0,023 + 14 * 0,002}{1 - \frac{0,6 + 4}{100}} = 4,24$$

$$SI = \frac{2}{\left( 1 - \frac{\text{inert \%}}{100} \right) \left( n + \frac{m}{4} \right) - \frac{O_2 *}{100}} = \frac{2}{\left( 1 - \frac{4}{100} \right) * \left( 1,11 + \frac{4,24}{4} \right) - \frac{0,6}{100}} = 0,96$$

\_\_\_\_\_ "