

tion No. 170 (Child Restraint Systems for Safer Transport of Children in Buses and Coaches)

Submitted by the Informal Working Group on Safe Transport of Children in Buses *

The text reproduced below has been prepared by the Informal Working Group on the Safe Transport of Children in Buses to align the text of the UN Regulations covering adult and child safety. The modifications to the current text of the UN Regulation are marked in bold for new or strikethrough for deleted characters.

I. Proposal

1. Introduction, amend to read:

~~Enhanced~~ Child Restraint System (~~E~~CRS) approved according to UN Regulation No. 129 **or UN Regulation No.44** which can be installed in vehicle seats using the **3-point** belt type and/or ISOFIX attachments can be used.

The Requirements defined in this UN Regulation do not apply to the ~~E~~CRS approved according to UN Regulation 129 **or UN Regulation No.44**.

In case that the vehicle seat is also intended to be used by an adult, the vehicle seats and its safety-belt anchorages shall be approved according to UN Regulation No. 14 and UN Regulation No. 80 or UN Regulation No. 17 if applicable.

Paragraph 3.23.1. and 3.23.2., amend to read:

"3.23.1. "Forward-facing seat" means a seat which can be used while the vehicle is in motion and which faces towards the front of the vehicle in such a manner that the vertical plane of symmetry of the seat forms an angle of less than +10° or -10° with the vertical plane of symmetry of the vehicle.

3.23.2. "Rearward-facing seat" means a seat which can be used while the vehicle is in motion and which faces towards the rear of the vehicle in such a manner that the vertical plane of symmetry of the seat forms an angle of less than +10° or -10° with the vertical plane of symmetry of the vehicle."

Paragraph 4.2.2., amend to read:

"4.2.2. Samples of the ~~Enhanced~~ Child Restraint System requested by the Technical Service responsible for conducting the test;"

Paragraph 4.2.3., amend to read:

"4.2.3. A 10-metre length of each type of strap used in the ~~Enhanced~~ Child Restraint System;"

* In accordance with the programme of work of the Inland Transport Committee for 2024 as outlined in proposed programme budget for 2024 (A/78/6 (Sect. 20), table 20.5), the World Forum will develop, harmonize and update UN Regulations in order to enhance the performance of vehicles. The present document is submitted in conformity with that mandate.



Paragraph 5.2., amend to read:

"5.2. Integral Child Restraint Systems that can be used forward and rearward facing, shall have the following label permanently attached on the part hosting the child and visible to the person installing the Child **Restraint System**:

The manufacturer shall be permitted to include the word "months" to explain the symbol "M" in the label. The word "months" should be in a language commonly spoken in the country ~~or countries~~ where the vehicle with the Child Restraint System is registered. More than one language is allowed.

Figure 1
Labels for a Forward- and a Rearward-Facing Child Restraint System

Minimum label size: 40 mm x 40 mm

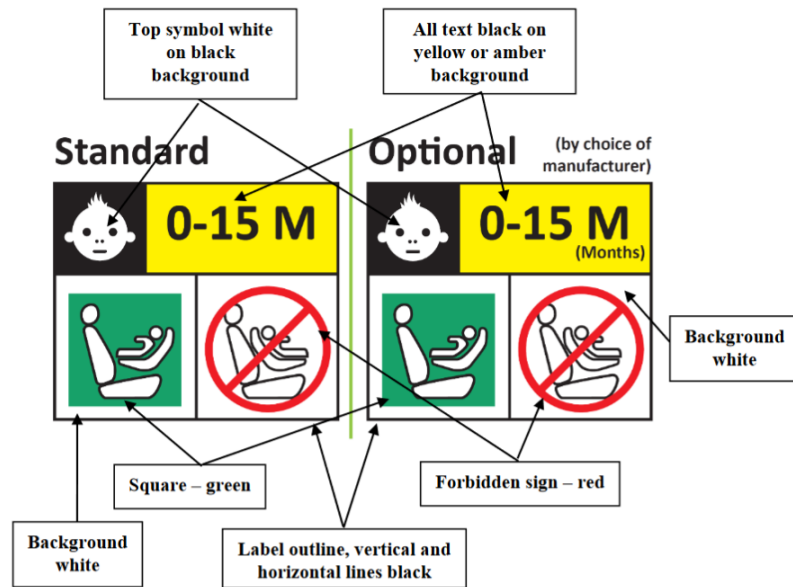

Integral Child Restraint Systems that can be used forward facing only shall have the following label permanently attached on the part hosting the child and visible to the person installing the child:

The manufacturer shall be permitted to include the word "months" to explain the symbol "M" in the label. The word "months" should be in a language commonly spoken in the country or countries where the vehicle is registered. More than one language is allowed.

Figure 2
Label for a Forward-Facing Child Restraint System

Minimum label size: 40 mm x 40 mm

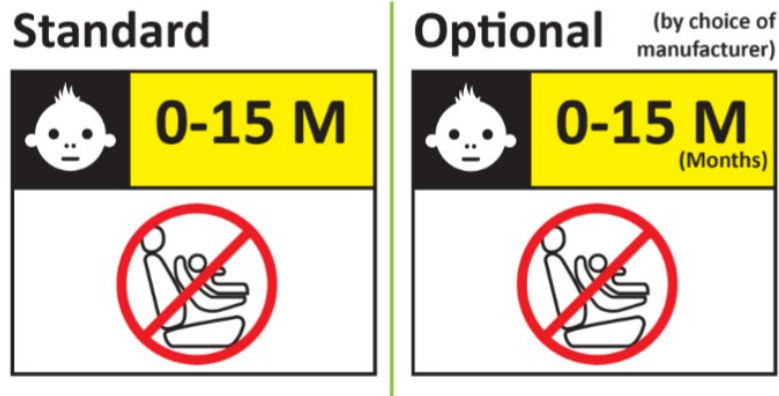

Paragraph 5.5., amend to read:

"5.5. Any removable insert, shall have a permanently attached label to indicate the brand, model and size range of the ~~Enhanced~~ Child Restraint System to which it belongs. The minimum size of the label shall be 40 x 40 mm or the equivalent area.

Paragraph 5.6., amend to read:

"5.6. Child Restraint Systems shall have a permanently attached label to inform the user of the appropriate method of restraint of the child over the entire stature range declared by the manufacturer. The label shall be visible to the person installing the ~~enhanced~~ child restraint system in a vehicle and when a child is seated in the restraint. The label shall have a minimum size of 40 × 60mm or the equivalent area and shall feature a pictogram of each restraint configuration adjacent to the stature range.

If the Child Restraint System is to be used in combination with an impact shield and/or inserts, the information on where they are stowed shall be available."

Paragraph 7.2.1.5., amend to read:

"7.2.1.5. All restraint devices utilizing a lap strap shall positively guide the lap strap to ensure that the loads transmitted by the lap strap are transmitted through the pelvis. The assembly shall not subject weak parts of the child's body (abdomen, crotch, etc.) to excessive stresses.

In the case of non-integral Child restraint Systems, the lap portion of the adult safety-belt shall be positively guided on both sides to ensure that the loads transmitted by the adult lap belt are transmitted through the pelvis. The positive guidance of loads over the pelvis shall be realized from the moment that the child is installed; the lap belt shall pass over the top of the thigh, just touching the fold with the pelvis. The angles α and β between the tangent line in which the belt touches the thighs and the horizontal shall be greater than 10° as show in in figure 43.

Figure 13
Strapped-in Child

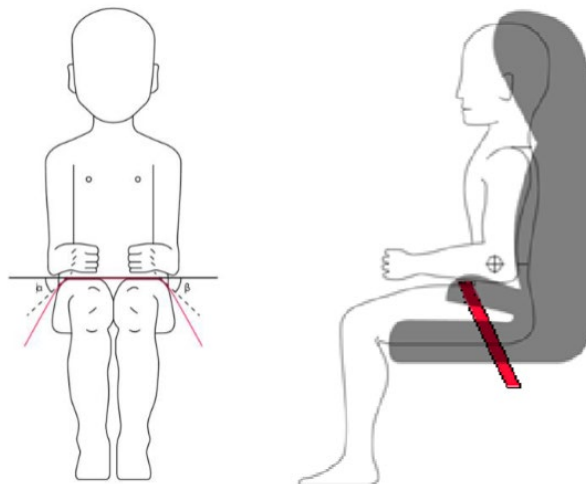

The shoulder portion of the adult safety belt shall be positively guided to ensure that the child torso and neck do not escape."

Paragraph 7.3.3., amend to read:

"7.3.3. Internal geometric characteristics

The Technical Service conducting the approval tests shall verify that the internal dimensions of the ~~Enhanced~~ Child Restraint System conform to the requirements of Annex 3. The minimum dimensions for shoulder breadth, hip breadth and sitting height shall be fulfilled simultaneously for any stature within the size range declared by the manufacturer.

Integral Child Restraint System shall also fulfil the minimum and maximum dimensions of shoulder height, for any stature within the size range declared by the manufacturer.

Integral ~~Enhanced~~ Child Restraint Systems that feature an impact shield shall also be capable of being adjusted to fulfil:

- (a) The 5th percentile upper leg thickness and 5th percentile abdomen depth, simultaneously to the 5th percentile shoulder height;
- (b) The 95th percentile upper leg thickness and 95th percentile abdomen depth, simultaneously to the 95th percentile shoulder height, shoulder breadth, hip breadth and sitting height.

For any stature within the size range declared by the manufacturer.

Non-integral ~~Enhanced~~ Child Restraint System shall also fulfil the maximum dimensions of shoulder height, for any stature within the size range declared by the manufacturer."

Paragraph 8.1.3.1., amend to read:

"8.1.3.1. The metal items of the Child Restraint System shall be positioned in a test chamber as prescribed in Annex 4. In the case of a Child Restraint Systems ~~System~~ incorporating a retractor, the strap shall be unwound to full length less 100 ± 3 mm. Except for short interruptions that may be necessary, for example, to check and replenish the salt solution, the exposure test shall proceed continuously for a period of 50 ± 0.5 hours."

Paragraph 8.1.3.2 Amend to read

"8.1.3.2. On completion of the exposure test the metal items of the Child Restraint System shall be gently washed, or dipped, in clean running water with a

temperature not higher than 38 °C to remove any salt deposit that may have formed and then allowed to dry at room temperature of 18 °C to 25 °C for 24 ± 1 hours before inspection in accordance with paragraph ~~6.6.1.2~~ 8.1.2 above."

Paragraph 8.3.4., amend to read:

"8.3.4. In the case of a Child Restraint System making use of ~~or~~ a shoulder strap positioner, the dynamic test shall be carried out as follows:

Paragraph 8.3.6.6.1. and 8.3.6.6.1.1., amend to read:

"8.3.6.6.1. No part of the head of the dummy shall pass beyond the planes BA as defined in Figure 24 below.

This shall be judged up to 300 ms or the moment that the dummy has come to a definitive standstill, whatever occurs first.

8.3.6.6.1.1. Where a test is conducted in accordance with paragraph 8.3.4.2. above, a tolerance of +10 per cent shall be applicable to the head excursion value distance between Cr point and plane AB.

Figure 24
Arrangement for Testing a Forward-Facing Device

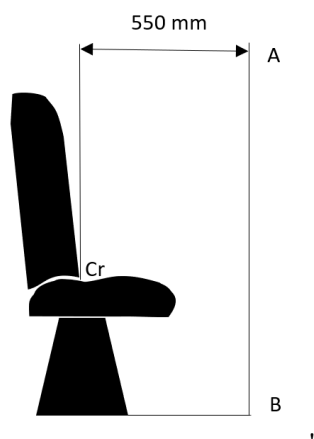

Paragraph 8.3.6.5.1., Table 1, amend to read:

"8.3.6.5.1 Injury assessment criteria for frontal and rear impact as in Table 1.

Table 1
Injury Assessment Criteria

Criterion	Abbreviation	Unit	Q0	Q1	Q1.5	Q3	Q6	Q10
Head performance criterion (only in case of contact in vehicle-testing during in-vehicle testing)	HPC * (15)		600	600	600	800	800	800
Resultant head acceleration 3 ms	A head cum 3 ms ***	g	75	75	75	80	80	80
Upper neck tension Force	Fz	N				For monitoring purposes only **		
Upper neck flexion moment	My	Nm						
Resultant chest acceleration 3 ms	A chest cum 3 ms ***	g	55	55	55	55	55	55
Chest deflection	TBC	mm	NA			For monitoring purposes only **		
Abdominal pressure ****	P	Bar	NA	NA	1.2	1.0	1.0	1.2

- * HPC: see Annex 6, Appendix 2.
- ** To be reviewed according to UN Regulation No. 129.
- *** Cum 3ms means cumulative 3ms value.
- **** Abdominal pressure, the highest recorded value is applicable for injury assessment (i.e. when the right-handed sensors record 1.3 bar and the left-handed sensor 1.0 bar, the recorded 1.3 bar is to be used for injury assessment).

Paragraph 8.3.6.6.2., amend to read:

"8.3.6.6.2. During the dynamic tests, no part of the ~~Enhanced~~ Child Restraint System restraining the child in position shall fail. This includes buckles, locking systems and reclining systems, except were identified as a load limiting device."

Paragraph 8.3.7.1.1.9.1., amend to read:

"8.3.7.1.1.9.1. Installation of Integral **Child Restraint Systems**.

The dummy shall be placed in the Child Restraint System separate from the seat-back of the chair by a flexible spacer. The spacer shall be 2.5 cm thick and 6 cm wide. It shall have length equal to the shoulder height less the thigh height, both in the sitting position and relevant to the dummy size being tested. The resulting height of the spacer is listed in the table 2 below for the different dummy sizes. The board should follow as closely as possible the curvature of the chair and its lower end should be at the height of the dummy's hip joint.

Table 2
Height of the Spacer

<i>Q0</i>	<i>Q1</i>	<i>Q1.5</i>	<i>Q3</i>	<i>Q6</i>	<i>Q10</i>
Dimensions in mm					
173 ± 2	229 ± 2	237 ± 2	250 ± 2	270 ± 2	359 ± 2

Adjust the CRS belt in accordance with the manufacturer's instructions, but to a tension of 250 ± 25 N above the adjuster force, with a deflection angle of the strap at the adjuster of 45 ± 5°, or alternatively, the angle prescribed by the manufacturer.

The spacer shall then be removed and the dummy pushed towards to the seat back. Distribute the slack evenly throughout the harness."

Paragraph 8.3.7.1.1.9.2., amend to read:

"8.3.7.1.1.9.2. Installation of non-Integral **Child Restraint Systems**.

The dummy shall be placed in the Child Restraint System.

Pull the upper torso webbing out of the retractor horizontally at a position via the centre of the dummy and allow it to retract. Repeat this operation four times. The shoulder belt should be at the position between the area which shall not be taken off from shoulder and shall not contact with the neck. Apply a 9 N to 18 N tension load to the lap belt. Allow the excess webbing in the shoulder belt to be retracted by the rewind force of the retractor."

Paragraph 8.3.7.1.1.9.3., amend to read:

"8.3.7.1.1.9.3. After installation. After installation, the dummy position shall be adjusted so that: The dummy center line shall be aligned exactly with the center line of Child Restraint System. The arms of the dummy shall be positioned symmetrically. Elbows shall be positioned in such a way that the upper arms are closely aligned with the sternum. Hands shall be positioned on the thighs. Legs shall be positioned parallel to one another or at least symmetrically.

Example for arm alignment is show in in Figure 35:

Figure 35
Examples of Arm Alignment

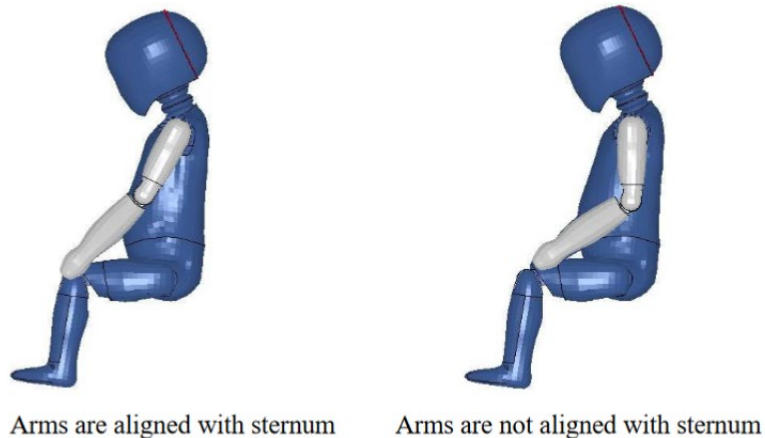

Paragraph 8.4.1.7.1.1., amend to read:

"8.4.1.7.1.1. An ~~Enhanced~~ Child Restraint Systems System having already undergone the dynamic test prescribed in paragraph 8.3. below shall be used for this test."

Paragraph 8.4.1.7.3.3.1., amend to read:

"8.4.1.7.3.3.1. For the strength test two samples have to be used. All adjusters, except for adjusters mounted directly on an ~~Enhanced~~ Child Restraint Systems are included in the test."

Paragraph 8.4.2.9.1., amend to read:

"8.4.2.9.1. Conditioning test for adjusters connected to a strap (not directly mounted to the ~~Enhanced~~ Child Restraint System).

Install the largest dummy for which the restraint is intended, as if for the dynamic test. Mark a reference line on the strap where the free end of the strap enters the adjuster.

Remove the dummy and place the restraint in the conditioning rig shown in Figure 2, Annex 8.

The strap shall be cycled for a total distance of not less than 150 mm through the adjuster. This movement shall be such that at least 100 mm of strap on the side of the reference line towards the free end of the strap. If the length of strap from the reference line to the free end of the strap is insufficient for the movement described above, the 150 mm of movement through the adjuster shall be from the fully extended strap position.

The frequency of cycling shall be 10 ± 1 cycles/minute, with a velocity on "B" of 150 ± 1 mm/s.

This process shall be conducted for each adjuster that is part of the retention system of the child within the restraint."

Paragraph 8.4.4.3.6.2.2., amend to read:

"8.4.4.3.6.2.2. After exposure, the strap shall be kept for a minimum of 24 hours in an atmosphere having a temperature of $23 \text{ }^\circ\text{C} \pm 5 \text{ }^\circ\text{C}$ and a relative humidity of 50 ± 10 per cent. The breaking load shall be determined within five minutes after the removal of the strap from the conditioning installation."

Paragraph 8.4.5.1., amend to read:

"8.4.5.1. Buckle assemblies, retractors, adjusters and lock-off devices that are liable to be affected by temperature, shall be subject to the temperature test

specified in paragraph 8.4.5.3. below. This requirement is applicable to any such components that are found on the ~~Enhanced~~ Child Restraint System, regardless of the means of restraint." *Annex 2*, amend to read:

"...

The Child Restraint Systems which bear the above approval mark is a device used for 40 cm – 70 cm size range and mass limit of 24 kg; it is approved in France (E 2) under the number 002439. The approval number indicates that the approval was granted in accordance with the requirements of the UN Regulation concerning the approval of **Child Restraint Systems for the Safer Transport of Children in Buses and Coaches** as amended by the YY series of amendments. In addition the name of the regulation has to be identified on the approval mark followed by the series of amendment according to which the approval has been granted."

Annex 3, amend to read:

"Annex 3

Internal Measurements

Figure 1
Child dimension

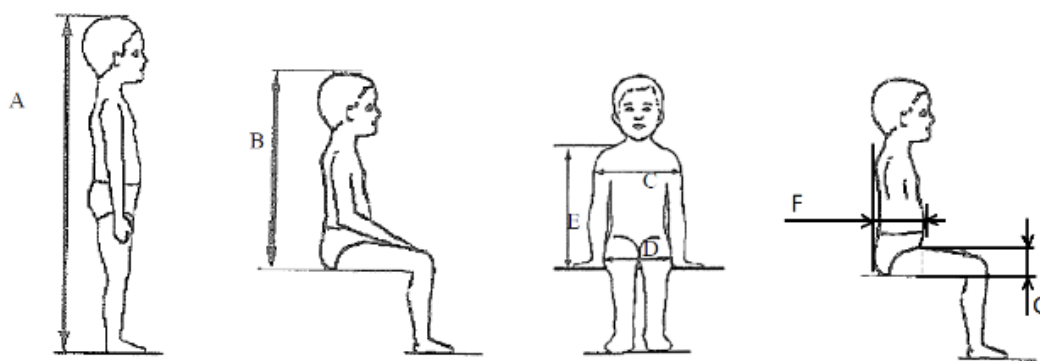

Applicable to all CRS

Stature A	Min Sitting height cm B	Min Shoulder breadth cm C	Min Hip breadth cm D	Min Shoulder height cm E1	Max Shoulder height cm E2
	95 th percentile	95 th percentile	95 th percentile	5 th percentile	95 percentile
≤ 40				< 27.4	
45	39.0	12.1	14.2	27.4	29.0
50	40.5	14.1	14.8	27.6	29.2
55	42.0	16.1	15.4	27.8	29.4
60	43.5	18.1	16.0	28.0	29.6
65	45.0	20.1	17.2	28.2	29.8
70	47.1	22.1	18.4	28.3	30.0
75	49.2	24.1	19.6	28.4	31.3
80	51.3	26.1	20.8	29.2	32.6
85	53.4	26.9	22.0	30.0	33.9
90	55.5	27.7	22.5	30.8	35.2
95	57.6	28.5	23.0	31.6	36.5
100	59.7	29.3	23.5	32.4	37.8
105	61.8	30.1	24.9	33.2	39.1
110	63.9	30.9	26.3	34.0	40.4
115	66.0	32.1	27.7	35.5	41.7
120	68.1	33.3	29.1	37.0	43.0
125	70.2	33.3	29.1	38.5	44.3
130	72.3	33.3	29.1	40.0	46.1
135	74.4	33.3	29.1	41.5	47.9
140	76.5	34.2	29.6	43.0	49.7
145	78.6	35.3	30.8	44.5	51.5
150	81.1	36.4	32.0	46.3	53.3

Additional internal dimensions for CRS with impact shields systems

Min Abdomen depth cm F1	Max Abdomen depth cm F2	Min Upper leg thickness cm G1	Max Upper leg thickness cm G2
5 th percentile	95 percentile	5 th percentile	95 th percentile
Not allowed for three these dimensions and stature below 76 cm			
12.5	15.1	5.7	8.4
12.7	15.7	5.8	8.4
12.9	16.2	5.9	8.5
13.1	16.8	6.2	8.5
13.3	17.8	6.5	8.9
13.5	18.2	6.5	9.6
13.6	18.8	6.6	10.3
13.9	19.6	6.6	10.3
13.9	19.9	6.6	10.4
14.3	20.2	6.8	10.5
14.7	20.7	7.5	10.9
Not allowed for these dimensions and stature over 125 cm			

All lateral dimensions are measured under a contact force of 50 N with the devices described in Figure 2 and Figure 3 of this annex and the following tolerances will be applied:

Minimum Sitting height:

- (a) Up to 87 cm B – 5 per cent;
- (b) From stature from 87 cm and up to 150 cm B – 10 per cent;
- (c) Minimum shoulder height (5th percentile): E1 -2+0 cm;

Maximum shoulder height (95th percentile): E2 -0+2 cm;

The mass of the devices described in Figure 2 and Figure 3 of this annex shall be 10 kg ± +/- 1 kg.

Figure 2
Measurement Device for Child Restraint Systems – Side and Front View of the Measuring Device

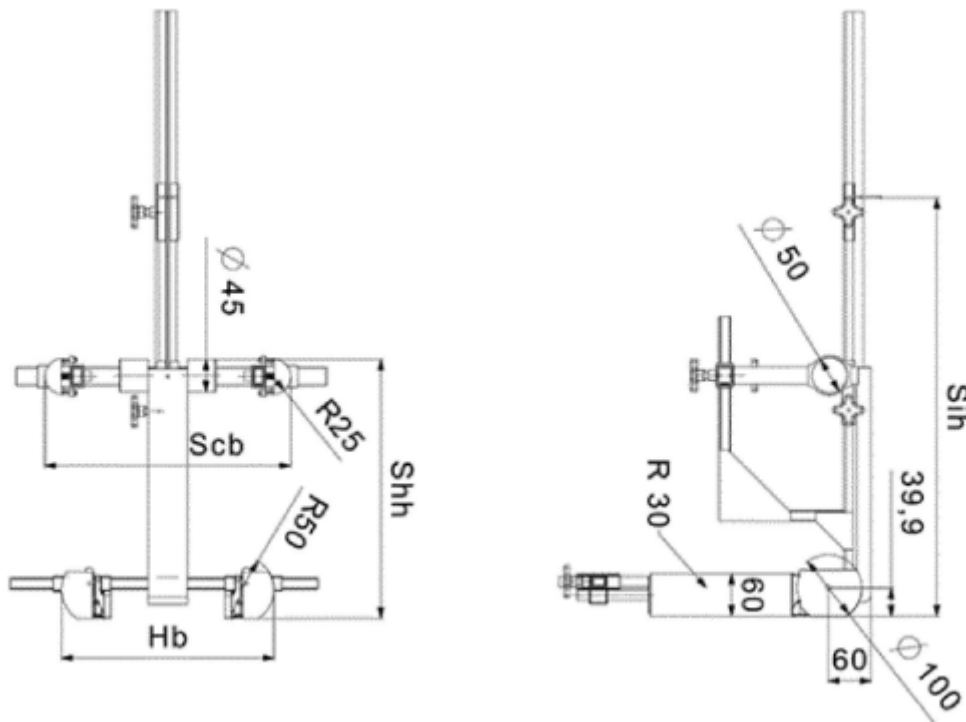
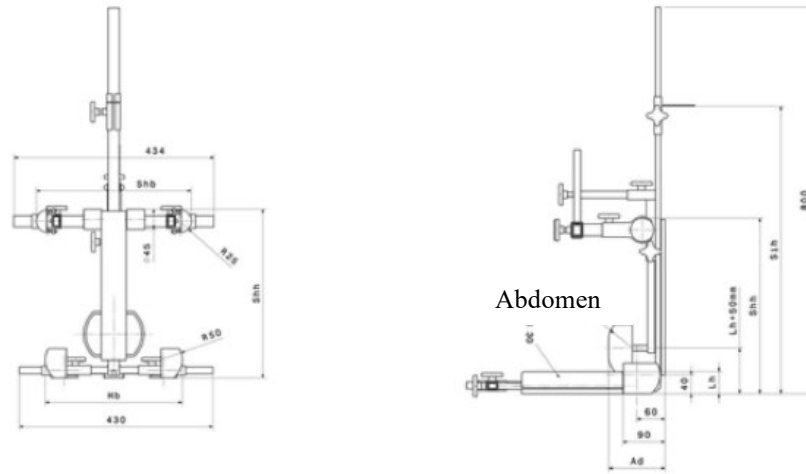
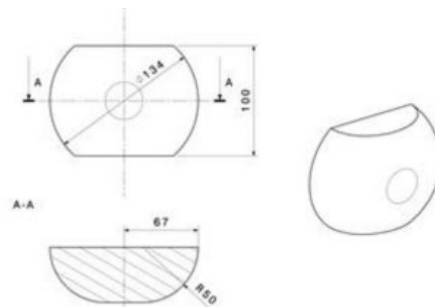

Figure 3
Side and Front View of the Measuring Device for Measurements of Child Restraint Systems that Feature an Impact Shield



Abdomen details



All dimensions in mm

"

Annex 6, Appendix 2, Paragraph 1.2., insert footnote ¹ and amend to read

"1.2. If that is not the case, a calculation of the value of HPC is made, on the basis of the acceleration (a)¹,~~‡~~ by the following expression:

$$\text{HPC} = (t_2 - t_1) \left[\frac{1}{t_2 - t_1} \int_{t_1}^{t_2} \text{adt} \right]^{2.5}$$

"

Annex 8, amend to read:

"...

1. Conditioning for adjusters mounted directly on ~~Enhanced~~ Child Restraint Systems (Figure 1)

...

1.1.2. Attach the ~~adjusted~~ **adjuster** part of the integral harness to the pulling device A.

..."

¹ The acceleration (a) referring to the centre of gravity is calculated from the triaxial components of the acceleration measured with a CFC of 1 000.

Annex 9, paragraph 1, amend to read:

"Micro Slip

Figure 1
Micro slip test method

Total travel 300 ± 20 mm

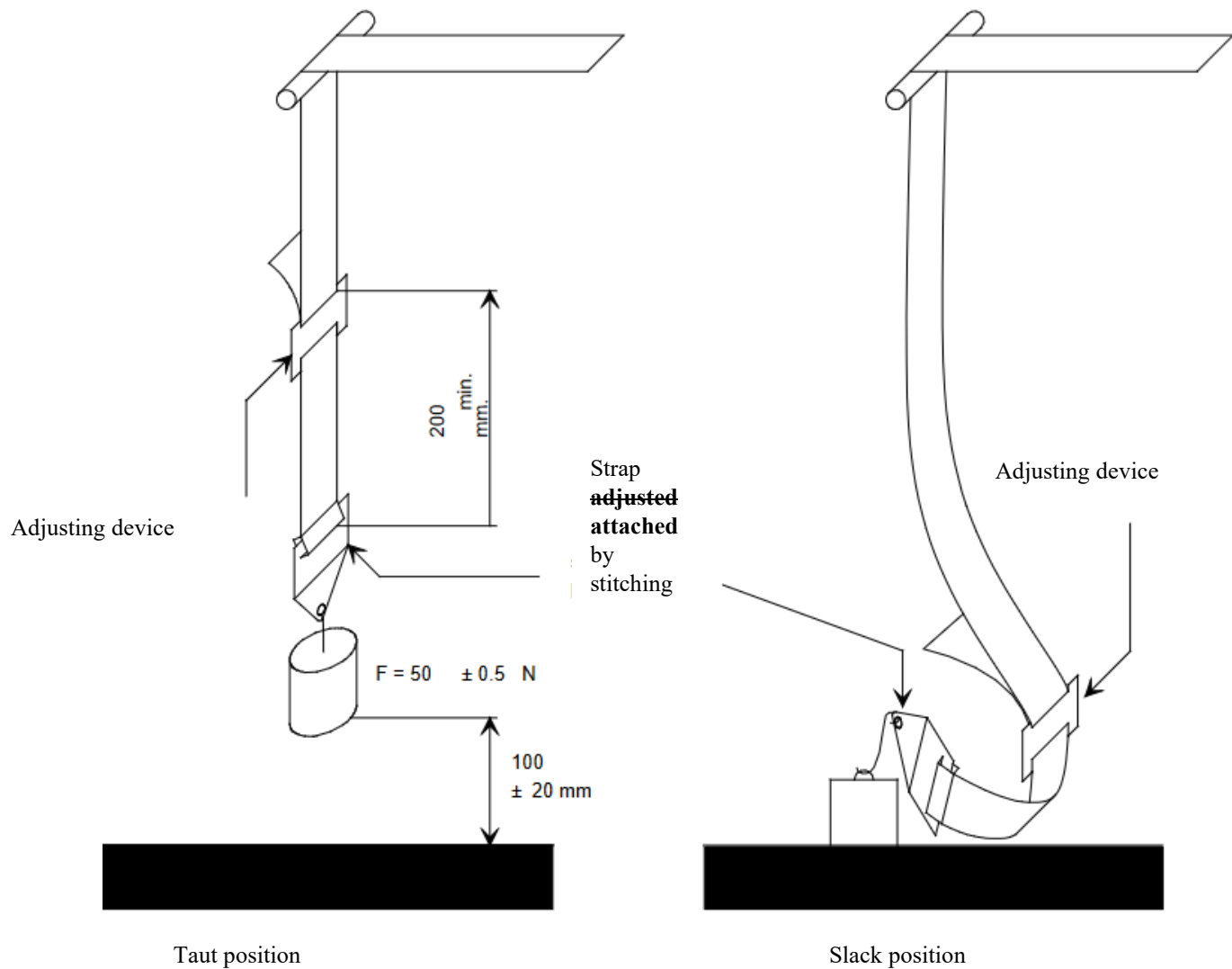

The load of 50 N on the testing device shall be vertically guided in such a way as to prevent load-swing and twisting of the strap.

The attaching device shall be fixed to the load of 50 N in the same manner as in the vehicle.

Annex 10, Figure 2, Example 2, amend to read:

"Example 2

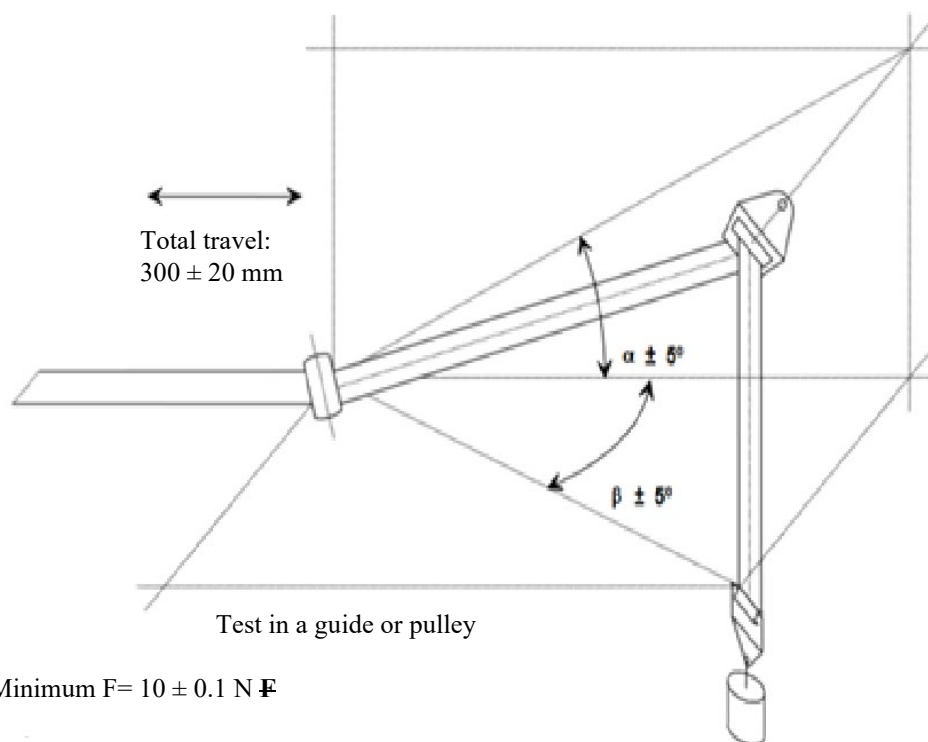

Where α and β reproduce the angles as in the real installation (in the three dimensions)"

II. Justification

1. The purpose of this document is to add some editorial corrections on the text.
2. The figures are renumbered for better consistency.
3. Adding missing figures for internal measurement devices.