



Economic and Social Council

Distr.: General
26 August 2024

Original: English

Economic Commission for Europe

Inland Transport Committee

World Forum for Harmonization of Vehicle Regulations

194th session

Geneva, 12–15 November 2024

Item 4.8.4 of the provisional agenda

1958 Agreement:

Consideration of draft amendments to existing

UN Regulations submitted by GRSP

Proposal for Supplement 4 to 03 Series of Amendments to UN Regulation No. 100 (Electric power trained vehicles)

Submitted by the Working Party on Passive Safety*

The text reproduced below was adopted by the Working Party on Passive Safety (GRSP) at its seventy-fifth session (ECE/TRANS/WP.29/GRSP/75, para. 18). It is based on GRSP-75-01-Rev.3. It is submitted to the World Forum for Harmonization of Vehicle Regulations (WP.29) and to the Administrative Committee (AC.1) for consideration at their November 2024 sessions.

* In accordance with the programme of work of the Inland Transport Committee for 2024 as outlined in proposed programme budget for 2024 (A/78/6 (Sect. 20), table 20.5), the World Forum will develop, harmonize and update UN Regulations in order to enhance the performance of vehicles. The present document is submitted in conformity with that mandate.



Paragraphs 1.1. and 1.2., amend to read:

"1. Scope

- 1.1. Part I: Safety requirements with respect to the electric power train of road vehicles of categories M, N and O¹, with a maximum design speed exceeding 25 km/h, equipped with electric power train, excluding vehicles permanently connected to the grid.

However, for vehicles of category O, with batteries which are charged by (one of) the vehicle's e-axle(s), the requirements in part I of this UN Regulation shall apply, including those for the REESS (i.e. such batteries are considered as REESS even though they may not provide propulsion).

Part I of this regulation does not cover:

- (a) Post-crash safety requirements of road vehicles.
 - (b) High voltage components and systems which are not galvanically connected to the high voltage bus of the electric power train.
 - (c) High voltage electricity connection between the towing vehicle and the trailer(s)
- 1.2. Part II: Safety requirements with respect to the Rechargeable Electrical Energy Storage System (REESS), of road vehicles of categories M, N and O equipped with electric power train, excluding vehicles permanently connected to the grid.

Part II of this Regulation does not apply to a battery whose primary use is to supply power for starting the engine and/or lighting and/or other vehicle auxiliaries' systems.

However, for vehicles of category O, with batteries which are charged by (one of) the vehicle's e-axle(s), the requirements in part II of this UN Regulation shall apply, including those for the REESS (i.e. such batteries are considered as REESS even though they may not provide propulsion)."

Paragraph 2.1., amend to read:

"2. Definitions

For the purpose of this Regulation the following definitions apply:

- 2.1. "Active driving possible mode" means the vehicle mode when application of pressure to the accelerator pedal (or activation of an equivalent control) or release of the brake system will cause the electric power train to move the vehicle or in case of a vehicle of category O, the vehicle mode when coupled with a towing vehicle in active driving possible mode."

Insert new paragraph 2.54. and 2.55., to read:

- "2.54. "Trailer load compartment" means the compartment of the trailer described by the bodywork. The trailer load compartment is contained by the floor of the loading area and the inner surface of the bodywork as well as inside the storage equipment (e.g. pallet box etc.), if any.
- 2.55. "e-axle" means an axle mounted to a vehicle of category O, generating electrical energy and/or providing electrical propulsion.

¹ As defined in the Consolidated Resolution on the Construction of Vehicles (R.E.3.), document ECE/TRANS/WP.29/78/Rev.6, para. 2. –<https://unece.org/transport/standards/transport/vehicle-regulations-wp29/resolutions>

Batteries which are charged by (one of) the vehicle's e-axle(s) may include the necessary systems for physical support, thermal management, electronic control and casing."

Paragraph 5.1.1., amend to read:

"5. Part I: Requirements of a vehicle with regard to specific requirements for the electric power train

5.1.1. Protection against direct contact

Live parts shall comply with paragraphs 5.1.1.1. and 5.1.1.2. for protection against direct contact. Electrical protection barriers, enclosures, solid insulators and connectors shall not be able to be opened, separated, disassembled or removed without the use of tools or, for vehicles of categories N₂, N₃, M₂, M₃, O₃ and O₄, an operator controlled activation/deactivation device or equivalent.

However, connectors (including the vehicle inlet) are allowed to be separated without the use of tools, if they meet one or more of the following requirements:

- (a) They comply with paragraphs 5.1.1.1. and 5.1.1.2. when separated, or
- (b) They are provided with a locking mechanism (at least two distinct actions are needed to separate the connector from its mating component). Additionally, other components, not being part of the connector, shall be removable only with the use of tools or, for vehicles of categories N₂, N₃, M₂, M₃, O₃ and O₄, an operator controlled activation/deactivation device or equivalent in order to be able to separate the connector, or
- (c) The voltage of the live parts becomes equal or below 60 V DC or equal or below 30 V AC (rms) within 1 s after the connector is separated.

For vehicles of categories N₂, N₃, M₂, M₃, O₃ and O₄, conductive connection devices not energized except during charging of the REESS are exempted from this requirement if located on the roof of the vehicle out of reach for a person standing outside of the vehicle and, for vehicles of category M₂ and M₃, the minimum wrap around distance from the instep of the vehicle to the roof mounted charging devices is 3 m. In case of multiple steps due to an elevated floor inside the vehicle, the wrap around distance is measured from the bottom most step at entry, as illustrated in Figure 1."

Figure 1
Schematic to Measure Wrap-Around Distance

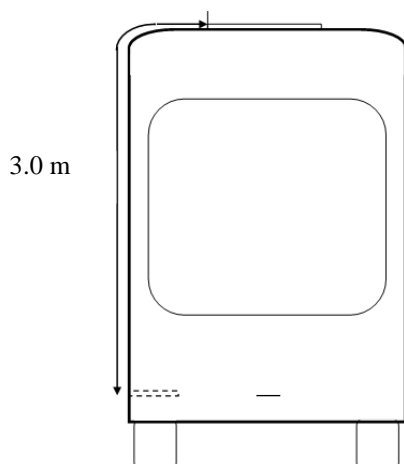

Paragraph 5.1.1.1., amend to read:

"5.1.1.1. For high voltage live parts inside the passenger compartment, or luggage compartment, or trailer load compartment, the protection degree IPXXD shall be provided."

Paragraph 5.1.1.2., amend to read:

"5.1.1.2. For high voltage live parts in areas other than the passenger compartment, or luggage compartment or trailer load compartment, the protection degree IPXXB shall be provided."

Paragraph 5.1.1.3., amend to read:

"5.1.1.3. Service disconnect

For a high voltage service disconnect which can be opened, disassembled or removed without tools, or for vehicles of categories N₂, N₃, M₂, M₃, O₃ and O₄, an operator controlled activation/deactivation device or equivalent, protection degree IPXXB shall be satisfied when it is opened, disassembled or removed."

Paragraph 5.1.1.4.2., amend to read:

"5.1.1.4.2. The symbol shall also be visible on enclosures and electrical protection barriers, which, when removed, expose live parts of high voltage circuits. This provision is optional to any connector for high voltage buses. This provision shall not apply to any of the following cases:

- (a) Where electrical protection barriers or enclosures cannot be physically accessed, opened, or removed; unless other vehicle components are removed with the use of tools;
- (b) Where electrical protection barriers or enclosures are located underneath the vehicle floor.
- (c) Electrical protection barriers or enclosures of conductive connection device for vehicles of categories N₂, N₃, M₂, M₃, O₃ and O₄ which satisfies the conditions prescribed in paragraph 5.1.1."

Paragraph 5.1.2.3., amend to read:

"5.1.2.3. In the case of vehicles which are intended to be connected to the grounded external electric power supply through the conductive connection between vehicle inlet and vehicle connector, a device to enable the galvanical connection of the electrical chassis to the earth ground for the external electric power supply shall be provided.

The device should enable connection to the earth ground before exterior voltage is applied to the vehicle and retain the connection until after the exterior voltage is removed from the vehicle.

Compliance to this requirement may be demonstrated either by using the connector specified by the vehicle manufacturer, by visual inspection or drawings.

The above requirements are only applicable for vehicles when charging from a stationary charging point, with a charging cable of finite length, through a vehicle coupler comprising a vehicle connector and a vehicle inlet."

Paragraphs 5.2.3. and 5.2.4. amend to read:

"5.2.3. Warning in the event of failure in REESS

The vehicle shall provide a warning to the driver when the vehicle is in active driving possible mode in the event specified in paragraphs 6.13. to 6.15.

In case of optical warning, the tell-tale shall, when illuminated, be sufficiently bright to be visible to the driver under both daylight and night-time driving conditions, when the driver has adapted to the ambient roadway light conditions.

This tell-tale shall be activated as a check of lamp function either when the propulsion system is turned to the "On" position, or when the propulsion system is in a position between "On" and "Start" that is designated by the manufacturer as a check position. This requirement does not apply to the tell-tale or text shown in a common space.

Notwithstanding the provisions above in case of vehicles of category O, the trailer shall provide an optical and/or audible warning to the driver of the towing vehicle in the event specified in paragraphs 6.13. to 6.15.

In case of vehicles of category O₃ and O₄, the trailer may provide to the towing vehicle a signal to address an optical warning according to this paragraph and/or an audible warning (e.g. transmission via CAN-Bus according to ISO 11992-2) in the event specified in paragraphs 6.13. to 6.15."

5.2.4. Warning in the event of low energy content of REESS.

For pure electric vehicles (vehicles equipped with a powertrain containing exclusively electric machines as propulsion energy converters and exclusively rechargeable electric energy storage systems as propulsion energy storage systems), a warning to the driver in the event of low REESS state of charge shall be provided. Based on engineering judgment, the manufacturer shall determine the necessary level of REESS energy remaining, when the driver warning is first provided.

In case of optical warning, the tell-tale shall, when illuminated, be sufficiently bright to be visible to the driver under both daylight and night-time driving conditions, when the driver has adapted to the ambient roadway light conditions.

This warning signal is not required for vehicles of category O."

Paragraphs 5.3.1. and 5.3.2. amend to read:

"5.3. Preventing accidental or unintended vehicle movement

5.3.1. At least a momentary indication shall be given to the driver each time when the vehicle is first placed in "active driving possible mode" after manual activation of the propulsion system.

However, this provision is optional under conditions where an internal combustion engine provides directly or indirectly the vehicle's propulsion power upon start up and for vehicles of category O.

To ensure that the vehicle of category O does not activate its driving mode independently, it shall be ensured that its propulsion system is only activated if the trailer is coupled to a towing vehicle and if a signal or command or action is transmitted to the trailer propulsion system.

5.3.2. When leaving the vehicle, the driver shall be informed by a signal (e.g. optical or audible signal) if the vehicle is still in the active driving possible mode. Moreover, in case of vehicles of category M₂ and M₃ with a capacity of more than 22 passengers in addition to the driver, this signal shall already be given when the drivers leave their seat.

However, this provision is optional under conditions where an internal combustion engine provides, directly or indirectly, the vehicle's propulsion power while leaving the vehicle or driver seat and for vehicles of category O."

Paragraphs 5.3.3. and new figure 3, amend to read :

"5.3.3. If the REESS can be externally charged, vehicle movement by its own propulsion system shall be impossible as long as the vehicle connector is physically connected to the vehicle inlet.

This requirement shall be demonstrated by using the vehicle connector specified by the vehicle manufacturer.

In case of vehicles of category O a trailer parking brake shall be automatically activated as long as the trailer connector is physically connected to the trailer inlet.

The above requirements are only applicable for vehicles when charging from a stationary charging point, with a charging cable of finite length, through a vehicle coupler comprising a vehicle connector and a vehicle inlet."

Annex 9C, paragraphs 3.2., amend to read:

"3.2. Test procedure

The Tested-Device shall be decelerated or accelerated in compliance with the acceleration corridors which are specified in Tables 1 to 3. The manufacturer shall decide whether the tests shall be conducted in either the positive or negative direction or both.

For each of the test pulses specified, a separate Tested-Device may be used.

The test pulse shall be within the minimum and maximum value as specified in Tables 1 to 3. A higher shock level and /or longer duration as described in the maximum value in Tables 1 to 3 can be applied to the Tested-Device if recommended by the manufacturer.

The test shall end with an observation period of 1 hour at the ambient temperature conditions of the test environment.

Figure 1
Generic description of test pulses

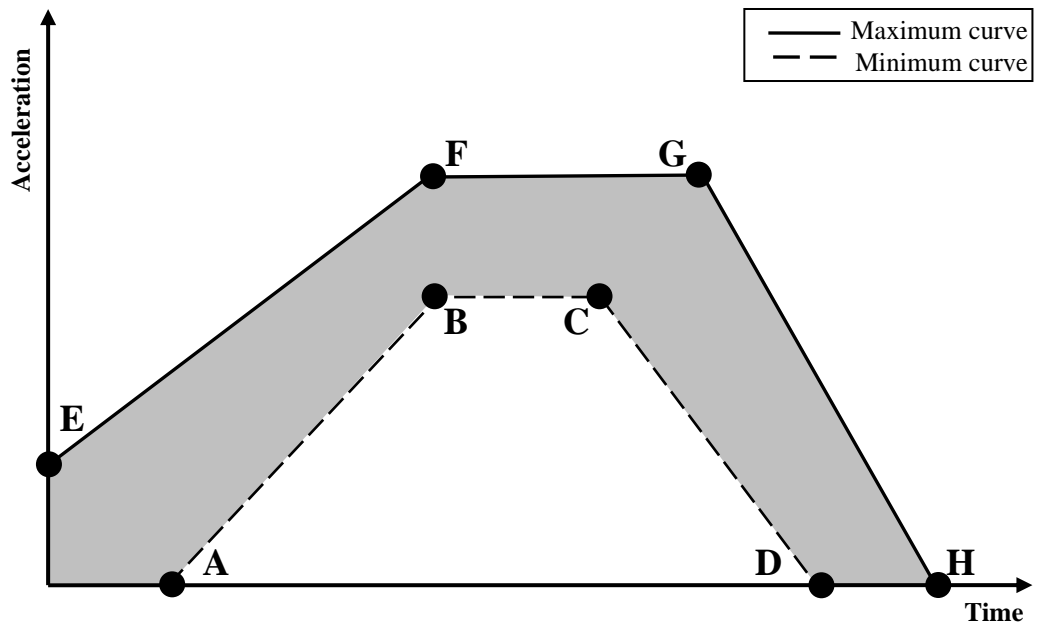

Table 1 for M₁, N₁, O₁ and O₂ vehicles¹:

Point	Time (ms)	Acceleration (g)	
		Longitudinal	Transverse
A	20	0	0
B	50	20	8
C	65	20	8
D	100	0	0

E	0	10	4.5
F	50	28	15
G	80	28	15
H	120	0	0

Table 2 for M₂ and N₂ vehicles:

Point	Time (ms)	Acceleration (g)	
		Longitudinal	Transverse
A	20	0	0
B	50	10	5
C	65	10	5
D	100	0	0
E	0	5	2.5
F	50	17	10
G	80	17	10
H	120	0	0

Table 3 for M₃, N₃, O₃, O₄ vehicles:

Point	Time (ms)	Acceleration (g)	
		Longitudinal	Transverse
A	20	0	0
B	50	6,6	5
C	65	6,6	5
D	100	0	0
E	0	4	2.5
F	50	12	10
G	80	12	10
H	120	0	0

The test shall end with an observation period of 1 hour at the ambient temperature conditions of the test environment."

Add new footnote 1 in Annex 9C Mechanical shock Paragraphs 3.2. table 1, to read:

- "1. For vehicles of category O₁ and O₂ at the request of the manufacturer the pulses defined in table 2 of Annex 9C paragraph 3.2 may be used if the maximum design speed of these vehicles of category O₁ and O₂ is limited to 100 km/h."