

**Economic and Social Council**Distr.: General  
8 August 2024

Original: English

---

**Economic Commission for Europe****Inland Transport Committee****World Forum for Harmonization of Vehicle Regulations****Working Party on Lighting and Light-Signalling****Ninety-first session**

Geneva, 22–25 October 2024

Item 7 (a) of the provisional agenda

**Device UN Regulations:****UN Regulation No. 148 (Light-Signalling Devices)****Proposal for a Supplement to the 01 series of amendments to UN Regulation No. 148 and to the 06, 07, 08 and 09 series of amendments to UN Regulation No. 48****Submitted by the expert from the International Automotive Lighting and Light-Signalling Expert Group\***

The text reproduced below was prepared by the expert from the International Automotive Lighting and Light-Signalling Expert Group (GTB) with the aim to introduce Direction Indicator Projections. The proposal is based on informal document GRE-90-16. The modifications to the existing text of the UN Regulation are marked in bold for new or strikethrough for deleted characters.

---

\* In accordance with the programme of work of the Inland Transport Committee for 2024 as outlined in proposed programme budget for 2024 (A/78/6 (Sect. 20), table 20.5), the World Forum will develop, harmonize and update UN Regulations in order to enhance the performance of vehicles. The present document is submitted in conformity with that mandate.



## I. Proposal

### A. Proposal for a Supplement to the 06, 07 and 08 series of amendments to UN Regulation No. 48

*Insert a new paragraph 2.5.22. to read:*

**“2.5.22. “Direction indicator projector” means a device used to provide direction indication projection.”**

*Insert new paragraphs 2.7.10. and 2.7.11., to read:*

**“2.7.10. “Basic element” of a direction indicator projection means the single shape composing the projected patterns.**

**2.7.11. “Direction indicator projection” means light signal projected on the ground by direction indicator projectors to provide enhanced recognition of direction indication to other road users.”**

*Insert a new paragraph 3.2.10., to read:*

**“3.2.10. Where direction indicator projections are provided, the list of patterns shall be provided by the manufacturer.”**

*Paragraph 5.9.1., amend to read:*

**“5.9.1. Direction-indicator lamps, direction indicator projections, the vehicle-hazard warning signal, amber side-marker lamps complying with paragraph 6.18.7. below, and the emergency stop signal shall be flashing lamps.”**

*Insert a new paragraph 5.9.4., to read:*

**“5.9.4. For direction indicator projections, the flash may be produced by the sequential projection of basic elements as specified in paragraph 5.12.5. of UN Regulation No. 148.”**

*Paragraph 5.15., amend to read:*

**“5.15. The colours of the light emitted by the lamps are the following:**

Main-beam headlamp:	White
...	...
Manoeuvring lamp:	White
<b>Direction indicator projection:</b>	<b>Amber”</b>

*Insert a new paragraph 5.36. and related sub-paragraphs, to read:*

**“5.36. General provision relating to direction indicator projection.**

**5.36.1. The patterns shall be explained in the owner's handbook.**

**5.36.2. When direction indicator projection(s) are provided,**

**5.36.2.1. only the basic elements listed in Annex 17 shall be used;**

**5.36.2.2. the pattern of each projection shall be constituted by one or more basic element(s) of the same type in a line;**

**5.36.2.3. the number, size, ratio and the spacing between the basic elements in the pattern are not restricted, provided that the requirements of paragraph 6.27.5 are met.**

**5.36.3. The light transmitted downwards by light-signalling devices is not considered a direction indicator projection.**

**5.36.4. When more than one projection is switched ON simultaneously, the projected patterns shall not overlap each other.**

- 5.36.5.** When the windshield wiper is switched ON and its continuous operation has occurred for a period of at least two minutes, the direction indicator projection(s) whose luminous intensity exceeds  $7.00 \cdot 10^3$  cd shall either be switched OFF, or have its luminous intensity reduced to a value less than or equal to  $7.00 \cdot 10^3$  cd. The conformity to this requirement shall be verified at the time of the direction indicator projector type approval and indicated in the related communication form.”

*Insert a new paragraph 6.27. and related sub-paragraphs, to read:*

- “6.27. Direction indicator projection**
- 6.27.1. Presence**
- Optional**
- 6.27.2. Number**
- Vehicles of categories M and N:**
- One front direction indicator projection on each side of the vehicle;
  - One rear direction indicator projection on each side of the vehicle;
  - One side direction indicator projection on each side of the vehicle.
- Vehicles of category O:**
- One rear direction indicator projection on each side;
  - One side direction indicator projection on each side.
- The projector(s) shall be type approved according to the 01 or subsequent series of amendments to UN Regulation No. 148.
- 6.27.3. Arrangement**
- Such that the provisions of paragraphs 6.27.5., 6.27.6., 6.27.9.1. to 6.27.9.3. apply.
- 6.27.4. Position**
- Such that the provisions of paragraphs 6.27.5., 6.27.6., 6.27.9.1. to 6.27.9.3. apply.
- 6.27.5. Projection area**
- 6.27.5.1. Front direction indicator projection**
- The lateral distance from the outer edge of the projection with respect to the extreme outer edge of the vehicle shall not be more than 1,500 mm.
- The longitudinal distance from the farthest edge of the projection shall not be more than 5,000 mm from the forward extreme outer edge of the vehicle and the rearward edge of the projection shall be not more than 500 mm rearward of the forward extreme outer edge of the vehicle.
- The inner boundary of the projection area is limited by a minimum distance of 300 mm from the longitudinal centre line of the vehicle (see figure below).

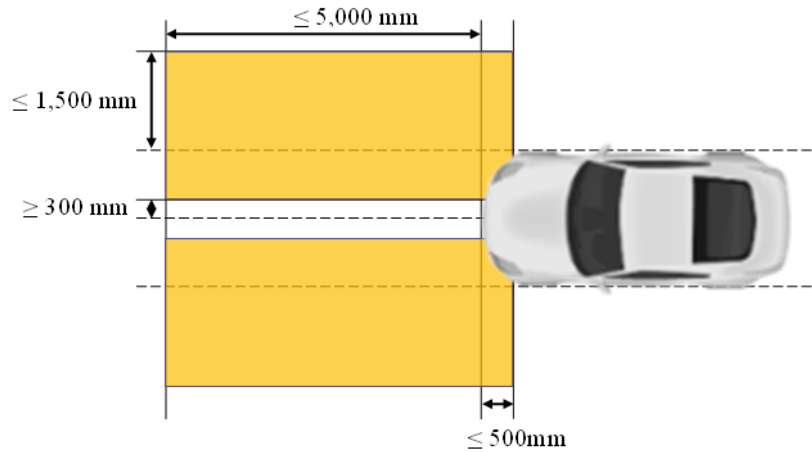

**6.27.5.2. Rear direction indicator projection**

The lateral distance from the outer edge of the projection with respect to the extreme outer edge of the vehicle shall not be more than 1,500 mm.

The longitudinal distance from the rearmost edge of the projection shall not be more than 2,000 mm from the rearward extreme outer edge of the vehicle and the forward edge of the projection shall be not more than 500mm forward of the rearward extreme outer edge of the vehicle.

The inner boundary of the projection area is limited by a minimum distance of 300 mm from the longitudinal centre line of the vehicle (see figure below).

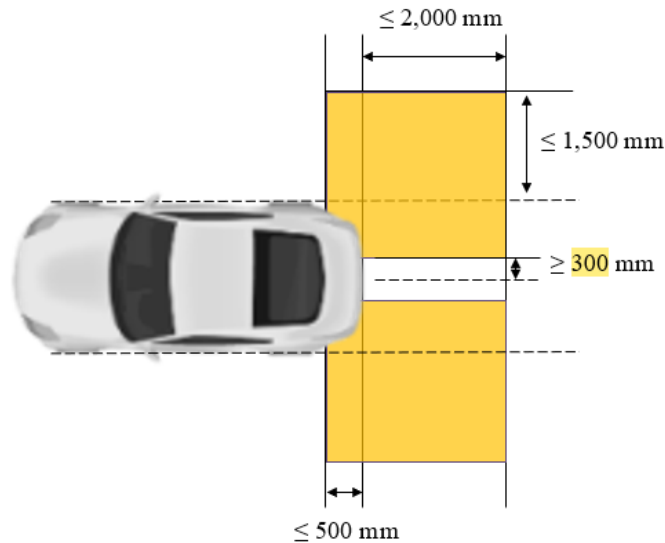

**6.27.5.3. Side direction indicator projection**

The lateral distance from the outer edge of the projection with respect to the extreme outer edge of the vehicle shall not be more than 1,500 mm.

In length, the projection area is limited by the vehicle length (see figure below)

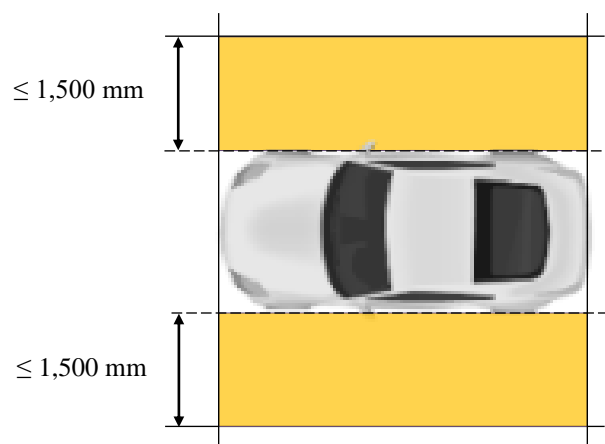

**6.27.5.4.** The patterns of each front direction indicator projection shall start with their closest edge within a zone limited by:

- a transverse plane 700 mm forwards of the front outer edge of the vehicle,
- a transverse plane 500 mm rearwards of the front outer edge of the vehicle,
- a longitudinal plane 700 mm outwards from the extreme outer edge of the vehicle and
- a longitudinal plane 300 mm outwards from the longitudinal median plane of the vehicle (see figure below)

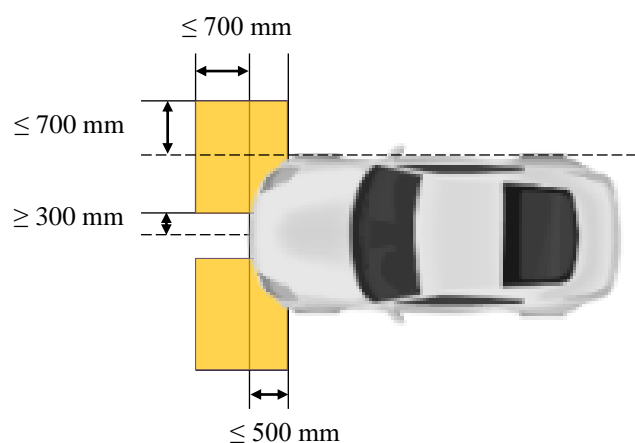

**6.27.5.5.** The patterns of each rear direction indicator projection shall start with their closest edge within a zone limited by:

- a transverse plane 700 mm rearwards of the rear outer edge of the vehicle,
- a transverse plane 500 mm forwards of the rear outer edge of the vehicle,
- a longitudinal plane 700 mm outwards from the extreme outer edge of the vehicle and
- a longitudinal plane 300 mm outwards from the longitudinal median plane of the vehicle (see figure below).

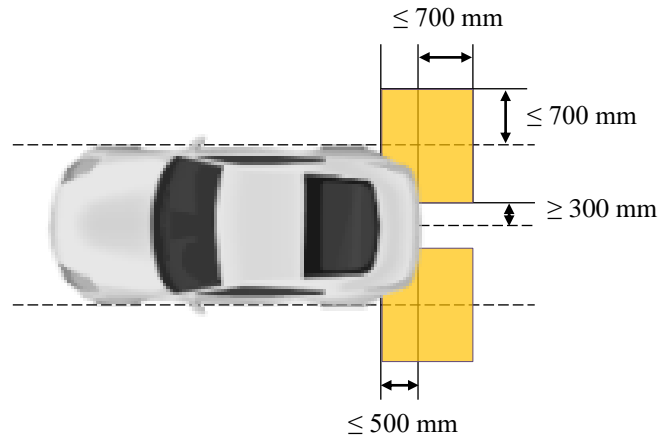

**6.27.5.6.** The patterns of each side direction indicator projection shall start with their closest edge within a zone limited by:

- a transverse plane at the front outer edge of the vehicle,
- a transverse plane at the rear outer edge of the vehicle and
- a longitudinal plane 700 mm outwards from the extreme outer edge (see figure below)

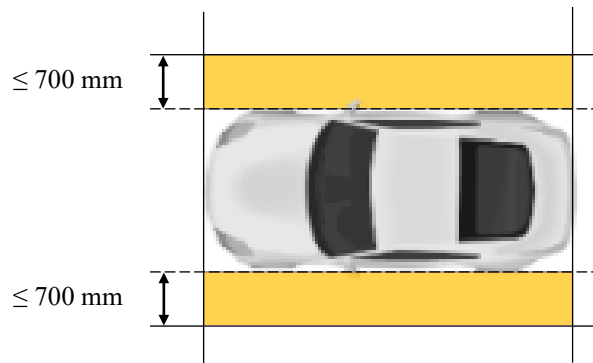

**6.27.6.** Orientation

Such that the requirements of paragraphs 6.27.5.1. or 6.27.5.2 or 6.27.5.3., whichever apply, are fulfilled.

**6.27.7.** Electrical connections

**6.27.7.1.** If provided, the direction indicator projection(s) shall be switched ON only when the direction indicator lamps on the same side are switched ON. When the direction indicator projection is switched ON, it shall flash in phase and at the same frequency of the direction indicator lamp.

**6.27.7.2.** The system which operates the direction indicator projections may be automatically and/or manually deactivated and/or reactivated.

**6.27.7.3.** A direction indicator projection capable of being activated in different modes (static or sequential), shall not switch between both modes once activated.

**6.27.7.4.** A direction indicator projection may be activated in sequential mode only if the corresponding direction indicator lamp is also activated in sequential mode.

**6.27.7.5.** All the direction indicator projections may be switched ON at the same time when the hazard warning signal is switched ON. In this case, the direction indicator projections shall flash in phase and at the same frequency as the hazard warning signal.

- 6.27.7.6.** If provided, the direction indicator projection(s) shall only be switched ON when one of the following conditions is met:
- (a) vehicle speed is equal to or less than 40 km/h, or
  - (b) vehicle speed is equal to or greater than 70 km/h.
- However, when the projection is already switched ON, it may remain switched ON until the direction indicator is deactivated.
- 6.27.8.** Tell-tale  
Optional
- 6.27.9.** Other requirements
- 6.27.9.1.** The technical service shall, to the satisfaction of the Type Approval Authority, perform a visual test to verify that there is no direct visibility of the apparent surface of any direction indicator projector, if viewed by an observer moving on the boundary of a zone on a transverse plane 10 m from the front of the vehicle, a transverse plane 10 m from the rear of the vehicle, and two longitudinal planes 10 m from each side of the vehicle; these four planes to extend from 1 m to 3 m above and perpendicular to the ground as shown in Annex 14.
- This requirement shall be deemed to be satisfied if the installation conditions comply with paragraph 5.12.1.2. (a) of UN Regulation No. 148.
- At the request of the applicant and with the consent of the Technical Service, this requirement may also be verified by a drawing or simulation.
- 6.27.9.2.** If the requirement of paragraph 6.27.9.1. is not fulfilled, the requirement of paragraph 5.12.1.2. (b) of UN Regulation No. 148 applies. The related indication shall be made in the Communication Form in Annex 1.
- 6.27.9.3.** For each direction indicator projection, only one line of patterns is allowed.
- 6.27.9.4.** If provided, the rear direction indicator projection(s) shall not be switched ON when the vehicle is in forward motion and the front direction indicator projection shall not be switched ON when the vehicle is in rearward motion, unless the horizontal angle of the direction of the projections to the median longitudinal plane of the vehicle exceeds 45°.”

*Annex 1,*

*Insert a new item 9.31. and related sub-items, to read:*

- “9.31. Direction indicator projection:**
- 9.31.1. Front direction indicator projection:** yes/no<sup>2</sup>
- 9.31.1.1. According to paragraph 5.36.5., its maximum luminous intensity is:**
- (a) less than or equal to 7.00·10<sup>3</sup> cd: yes/no<sup>2</sup>
  - (b) reduced to a value less than or equal to 7.00·10<sup>3</sup> cd: yes/no<sup>2</sup>
- 9.31.1.2. According to paragraph 6.27.9., the front direction indicator projector fulfils the requirements of paragraph**
- (a) 5.12.1.2. (a) of UN Regulation No. 148 yes/no<sup>2</sup>
  - (b) 5.12.1.2. (b) of UN Regulation No. 148 yes/no<sup>2</sup>
- 9.31.2. Rear direction indicator projection:** yes/no<sup>2</sup>
- 9.31.2.1. According to paragraph 5.36.5., its maximum luminous intensity is**
- (a) less than or equal to 7.00·10<sup>3</sup> cd: yes/no<sup>2</sup>
  - (b) reduced to a value less than or equal to 7.00·10<sup>3</sup> cd: yes/no<sup>2</sup>

- 9.31.2.2. According to paragraph 6.27.9., the rear direction indicator projector fulfils the requirements of paragraph
  - (a) 5.12.1.2. (a) of UN Regulation No. 148 yes/no<sup>2</sup>
  - (b) 5.12.1.2. (b) of UN Regulation No. 148 yes/no<sup>2</sup>
- 9.31.3. Side direction indicator projection: yes/no<sup>2</sup>
- 9.31.3.1. According to paragraph 5.36.5., its maximum luminous intensity is:
  - (a) less than or equal to 7.00·10<sup>3</sup> cd: yes/no<sup>2</sup>
  - (b) reduced to a value less than or equal to 7.00·10<sup>3</sup> cd: yes/no<sup>2</sup>
- 9.31.3.2. According to paragraph 6.27.9., the side direction indicator projector fulfils the requirements of paragraph
  - (a) 5.12.1.2. (a) of UN Regulation No. 148 yes/no<sup>2</sup>
  - (b) 5.12.1.2. (b) of UN Regulation No. 148 yes/no<sup>2</sup>

Annex 14,

Title, amend to read:

“Observing area towards the apparent surface of manoeuvring lamps, exterior courtesy lamps and direction indicator projectors”

Insert a new Annex 17, to read:

**“Annex 17**

**Basic element to be used for direction indicator projection patterns**

Basic element		Applicable function
Chevron		Front, Rear and Side Direction indicator projection • Colour of the Basic element: Amber
Note: Minor deviations from the shape of the basic element when projected on the road, due to technical restrictions or environmental conditions are considered to comply with the shape of the basic element.		

”

**B. Proposal for a Supplement to the 09 series of amendments to UN Regulation No. 48**

Insert a new paragraph 2.5.22., to read:

**“2.5.22. “Direction indicator projector” means a device used to provide direction indication projection.”**

Insert new paragraphs 2.7.10. and 2.7.11., to read:

**“2.7.10. “Basic element” of a direction indicator projection means the single shape composing the projected patterns.**

**2.7.11. “Direction indicator projection” means light signal projected on the ground by direction indicator projectors to provide enhanced recognition of direction indication to other road users.”**

Insert a new paragraph 3.2.10., to read:

**“3.2.10. Where direction indicator projections are provided, the list of patterns shall be provided by the manufacturer.”**



*Paragraph 5.9.1., amend to read:*

- “5.9.1. Direction-indicator lamps, **direction indicator projections**, the vehicle-hazard warning signal, amber side-marker lamps complying with paragraph 6.18.7. below, and the emergency stop signal shall be flashing lamps.”

*Insert a new paragraph 5.9.5., to read:*

- “**5.9.5. For direction indicator projections, the flash may be produced by the sequential projection of basic elements as specified in paragraph 5.12.5. of UN Regulation No. 148.**”

*Paragraph 5.15., amend to read:*

- “5.15. The colours of the light emitted by the lamps are the following:
- |  |   |
|--|---|
| Main-beam headlamp:                    | White   |
| ...                                    | ...   |
| Answer-back signal:                    | In accordance with the individual specifications applicable to the specific lamp used for the answer-back signal. |
| <b>Direction indicator projection:</b> | <b>Amber”</b>   |

*Insert a new paragraph 5.36. and related sub-paragraphs, to read:*

- “**5.36. General provision relating to direction indicator projection.**
- 5.36.1. The patterns shall be explained in the owner's handbook.**
- 5.36.2. When direction indicator projection(s) are provided,**
- 5.36.2.1. only the basic elements listed in Annex 17 shall be used;**
- 5.36.2.2. the pattern of each projection shall be constituted by one or more basic element(s) of the same type in a line;**
- 5.36.2.3. the number, size, ratio and the spacing between the basic elements in the pattern are not restricted, provided that the requirements of paragraph 6.28.5 are met.**
- 5.36.3. The light transmitted downwards by light-signalling devices is not considered a direction indicator projection.**
- 5.36.4. When more than one projection is switched ON simultaneously, the projected patterns shall not overlap each other.**
- 5.36.5. When the windshield wiper is switched ON and its continuous operation has occurred for a period of at least two minutes, the direction indicator projection(s) whose luminous intensity exceeds  $7.00 \cdot 10^3$  cd shall either be switched OFF, or have its luminous intensity reduced to a value less than or equal to  $7.00 \cdot 10^3$  cd. The conformity to this requirement shall be verified at the time of the direction indicator projector type approval and indicated in the related communication form.”**

*Insert a new paragraph 6.28. and related sub-paragraphs, to read:*

- “**6.28. Direction indicator projection**
- 6.28.1. Presence**
- Optional**
- 6.28.2. Number**
- Vehicles of categories M and N:**
- **One front direction indicator projection on each side of the vehicle;**
  - **One rear direction indicator projection on each side of the vehicle;**

- One side direction indicator projection on each side of the vehicle.

Vehicles of category O:

- One rear direction indicator projection on each side;
- One side direction indicator projection on each side.

The projector(s) shall be type approved according to the 01 or subsequent series of amendments to UN Regulation No. 148.

**6.28.3. Arrangement**

Such that the provisions of paragraphs 6.28.5., 6.28.6., 6.28.9.1. to 6.28.9.3. apply.

**6.28.4. Position**

Such that the provisions of paragraphs 6.28.5., 6.28.6., 6.28.9.1. to 6.28.9.3. apply.

**6.28.5. Projection area**

**6.28.5.1. Front direction indicator projection**

The lateral distance from the outer edge of the projection with respect to the extreme outer edge of the vehicle shall not be more than 1,500 mm.

The longitudinal distance from the farthest edge of the projection shall not be more than 5,000 mm from the forward extreme outer edge of the vehicle and the rearward edge of the projection shall be not more than 500 mm rearward of the forward extreme outer edge of the vehicle.

The inner boundary of the projection area is limited by a minimum distance of 300 mm from the longitudinal centre line of the vehicle (see figure below).

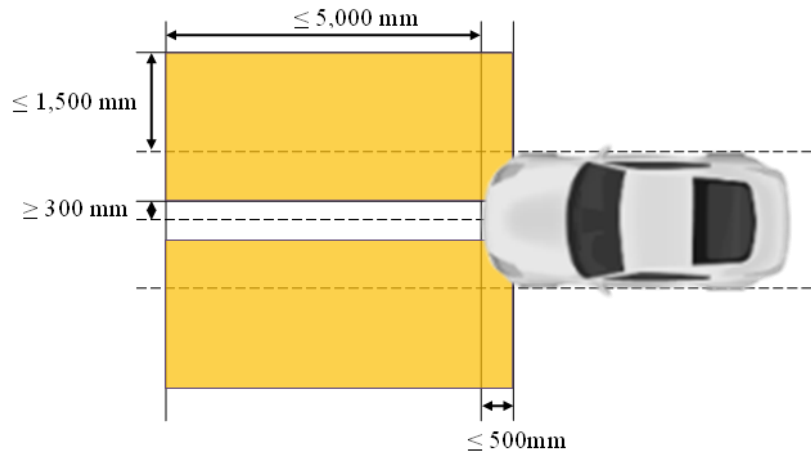

**6.28.5.2. Rear direction indicator projection**

The lateral distance from the outer edge of the projection with respect to the extreme outer edge of the vehicle shall not be more than 1,500 mm.

The longitudinal distance from the rearmost edge of the projection shall not be more than 2,000 mm from the rearward extreme outer edge of the vehicle and the forward edge of the projection shall be not more than 500 mm forward of the rearward extreme outer edge of the vehicle.

The inner boundary of the projection area is limited by a minimum distance of 300 mm from the longitudinal centre line of the vehicle (see figure below).

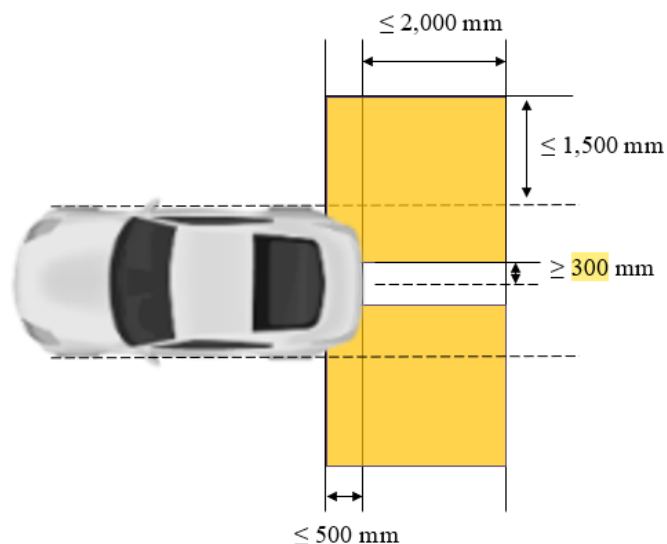

### 6.28.5.3. Side direction indicator projection

The lateral distance from the outer edge of the projection with respect to the extreme outer edge of the vehicle shall not be more than 1,500 mm.

In length, the projection area is limited by the vehicle length (see figure below).

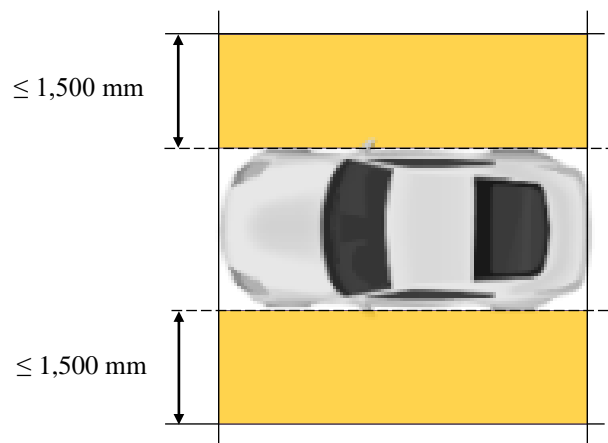

### 6.28.5.4. The patterns of each front direction indicator projection shall start with their closest edge within a zone limited by:

- a transverse plane 700 mm forwards of the front outer edge of the vehicle,
- a transverse plane 500 mm rearwards of the front outer edge of the vehicle,
- a longitudinal plane 700 mm outwards from the extreme outer edge of the vehicle and
- a longitudinal plane 300 mm outwards from the longitudinal median plane of the vehicle (see figure below).

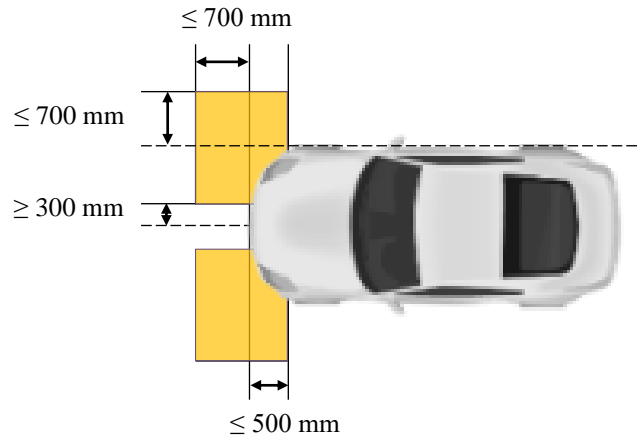

**6.28.5.5.** The patterns of each rear direction indicator projection shall start with their closest edge within a zone limited by:

- a transverse plane 700 mm rearwards of the rear outer edge of the vehicle,
- a transverse plane 500 mm forwards of the rear outer edge of the vehicle,
- a longitudinal plane 700 mm outwards from the extreme outer edge of the vehicle and
- a longitudinal plane 300 mm outwards from the longitudinal median plane of the vehicle (see figure below).

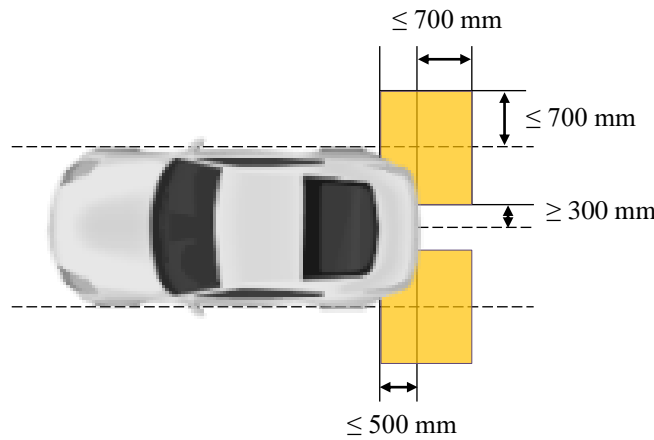

**6.28.5.6.** The patterns of each side direction indicator projection shall start with their closest edge within a zone limited by:

- a transverse plane at the front outer edge of the vehicle,
- a transverse plane at the rear outer edge of the vehicle and
- a longitudinal plane 700 mm outwards from the extreme outer edge (see figure below).

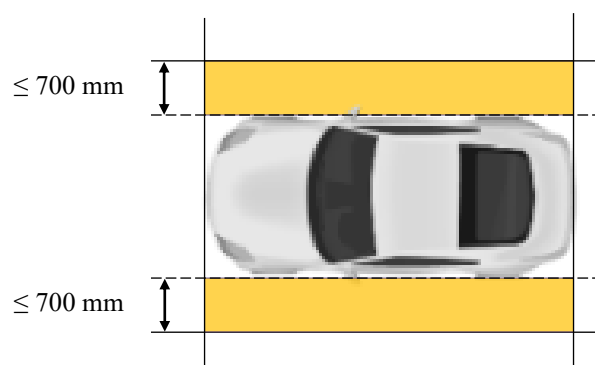

**6.28.6. Orientation**

Such that the requirements of paragraphs 6.28.5.1. or 6.28.5.2 or 6.28.5.3., whichever apply, are fulfilled.

**6.28.7. Electrical connections**

**6.28.7.1.** If provided, the direction indicator projection(s) shall be switched ON only when the direction indicator lamps on the same side are switched ON. When the direction indicator projection is switched ON, it shall flash in phase and at the same frequency of the direction indicator lamp.

**6.28.7.2.** The system which operates the direction indicator projections may be automatically and/or manually deactivated and/or reactivated.

**6.28.7.3.** A direction indicator projection capable of being activated in different modes (static or sequential), shall not switch between both modes once activated.

**6.28.7.4.** A direction indicator projection may be activated in sequential mode only if the corresponding direction indicator lamp is also activated in sequential mode.

**6.28.7.5.** All the direction indicator projections may be switched ON at the same time when the hazard warning signal is switched ON. In this case, the direction indicator projections shall flash in phase and at the same frequency as the hazard warning signal.

**6.28.7.6.** If provided, the direction indicator projection(s) shall only be switched ON when one of the following conditions is met:

- a) vehicle speed is equal to or less than 40 km/h, or
- b) vehicle speed is equal to or greater than 70 km/h.

However, when the projection is already switched ON, it may remain switched ON until the direction indicator is deactivated.

**6.28.8. Tell-tale**

**Optional**

**6.28.9. Other requirements**

**6.28.9.1.** The technical service shall, to the satisfaction of the Type Approval Authority, perform a visual test to verify that there is no direct visibility of the apparent surface of any direction indicator projector, if viewed by an observer moving on the boundary of a zone on a transverse plane 10 m from the front of the vehicle, a transverse plane 10 m from the rear of the vehicle, and two longitudinal planes 10 m from each side of the vehicle; these four planes to extend from 1 m to 3 m above and perpendicular to the ground as shown in Annex 14.

This requirement shall be deemed to be satisfied if the installation conditions comply with paragraph 5.12.1.2. (a) of UN Regulation No. 148.

At the request of the applicant and with the consent of the Technical Service, this requirement may also be verified by a drawing or simulation.

- 6.28.9.2.** If the requirement of paragraph 6.28.9.1. is not fulfilled, the requirement of paragraph 5.12.1.2. 9b) of UN Regulation No. 148 applies. The related indication shall be made in the Communication Form in Annex 1.
- 6.28.9.3.** For each direction indicator projection, only one line of patterns is allowed.
- 6.28.9.4.** If provided, the rear direction indicator projection(s) shall not be switched ON when the vehicle is in forward motion and the front direction indicator projection shall not be switched ON when the vehicle is in rearward motion, unless the horizontal angle of the direction of the projections to the median longitudinal plane of the vehicle exceeds 45°.”

*Annex 1,*

*Insert a new item 9.32. and related sub-items, to read:*

- “9.32. Direction indicator projection:**
- 9.32.1. Front direction indicator projection: yes/no<sup>2</sup>**
- 9.32.1.1. According to paragraph 5.36.5., its maximum luminous intensity is:**
- (a) less than or equal to 7.00·10<sup>3</sup> cd. yes/no<sup>2</sup>
- (b) reduced to a value less than or equal to 7.00·10<sup>3</sup> cd. yes/no<sup>2</sup>
- 9.32.1.2. According to paragraph 6.28.9., the front direction indicator projector fulfils the requirements of paragraph:**
- (a) 5.12.1.2. (a) of UN Regulation No. 148 yes/no<sup>2</sup>
- (b) 5.12.1.2. (b) of UN Regulation No. 148 yes/no<sup>2</sup>
- 9.32.2. Rear direction indicator projection: yes/no<sup>2</sup>**
- 9.32.2.1. According to paragraph 5.36.5., its maximum luminous intensity is:**
- (a) less than or equal to 7.00·10<sup>3</sup> cd. yes/no<sup>2</sup>
- (b) reduced to a value less than or equal to 7.00·10<sup>3</sup> cd. yes/no<sup>2</sup>
- 9.32.2.2. According to paragraph 6.28.9., the rear direction indicator projector fulfils the requirements of paragraph:**
- (a) 5.12.1.2. (a) of UN Regulation No. 148 yes/no<sup>2</sup>
- (b) 5.12.1.2. (b) of UN Regulation No. 148 yes/no<sup>2</sup>
- 9.32.3. Side direction indicator projection: yes/no<sup>2</sup>**
- 9.32.3.1. According to paragraph 5.36.5., its maximum luminous intensity is:**
- (a) less than or equal to 7.00·10<sup>3</sup> cd. yes/no<sup>2</sup>
- (b) reduced to a value less than or equal to 7.00·10<sup>3</sup> cd. yes/no<sup>2</sup>
- 9.32.3.2. According to paragraph 6.28.9., the side direction indicator projector fulfils the requirements of paragraph:**
- (a) 5.12.1.2. (a) of UN Regulation No. 148 yes/no<sup>2</sup>
- (b) 5.12.1.2. (b) of UN Regulation No. 148 yes/no<sup>2</sup>

*Annex 14,*

*Title, amend to read:*

“Observing area towards the apparent surface of manoeuvring lamps, exterior ~~and~~ courtesy lamps **and direction indicator projectors**”

Insert a new Annex 17, to read:

**“Annex 17**

**Basic element to be used for direction indicator projection patterns**

Basic element		Applicable function
Chevron		<b>Front, Rear and Side Direction indicator projection</b> • <b>Colour of the Basic element: Amber</b>
<b>Note: Minor deviations from the shape of the basic element when projected on the road, due to technical restrictions or environmental conditions are considered to comply with the shape of the basic element.</b>		

”

**C. Proposal for a Supplement to the 01 series of amendments to UN Regulation No. 148**

Paragraph 1., amend to read:

**“1 Scope**

This Regulation applies to the following light-signalling devices (lamps):

- Rear-registration plate illuminating lamps
- Direction indicator lamps
- Position lamps
- Stop lamps
- End-outline marker lamps
- Reversing lamps
- Manoeuvring lamps
- Rear fog lamps
- Parking lamps
- Daytime running lamps
- Side marker lamps
- **Direction indicator projectors ”**

Paragraph 2.2., amend to read:

“2.2. *“Lamps of different types”* means lamps, which differ in such essential respects as:

- (a) The trade name or mark:
  - (i) Lamps bearing the same trade name or mark but produced by different manufacturers are considered as being of different types;
  - (ii) Lamps produced by the same manufacturer differing only by the trade name or mark are considered as being of the same type.
- (b) The characteristics of the optical system (levels of intensity, light distribution angles, inclusion or elimination of components capable of altering the optical effects by reflection, refraction, absorption and/ or deformation during operation, etc.);

- (c) The category or categories of light source(s) used and/or the specific identification code (s) of the light source module(s);
- (d) The category of the lamp, if any;
- (e) The variable intensity control, if any;
- (f) The sequential activation of light sources, if any.

Nevertheless, direction indicators **lamps and direction indicator projectors** capable of being activated in different modes (sequential or not) without any modification of the optical characteristics of the lamp **or the projectors** do not constitute "*Direction indicators lamps or direction indicator projectors of different types*".

A change of the colour of the light source or the colour of any filter does not constitute a change of type.

The use of LED substitute light source(s) does not constitute a change of type. However, paragraph 4.8.1.6. applies.”

Insert a new paragraph 3.1.2.9., to read:

**“3.1.2.9. In the case of a direction indicator projector tested together with the direction indicator lamp according to the requirements of paragraph 5.12.1.2. (b), drawings showing the relative position of the projector and the lamp and the associated measurement report.”**

Table 1, amend to read:

“

<i>Lamp (function)</i>	<i>Symbol</i>	<i>Paragraph</i>
Daytime running lamp	RL	5.4.
...		
Stop lamp (variable)	S2	5.5.
<b>Front Direction indicator projector</b>	<b>DPF</b>	<b>5.12.</b>
<b>Rear Direction indicator projector</b>	<b>DPR</b>	<b>5.12.</b>
<b>Side Direction indicator projector</b>	<b>DPS</b>	<b>5.12.</b>

”

Table 2, amend to read:

“

<i>Series of amendments to the Regulation</i>	<i>00</i>	<i>01</i>	
<i>Lamp (function)</i>	<i>Change Index for the specific Lamp (function)</i>		
Daytime running lamp	0	1	
...			
Stop lamp (central high mounted)	0	1	
<b>Front Direction indicator projector</b>	-	<b>0</b>	
<b>Rear Direction indicator projector</b>	-	<b>0</b>	
<b>Side Direction indicator projector</b>	-	<b>0</b>	

”



*Insert a new paragraph 5.12. and related sub-paragraphs, to read:*

- “5.12. Direction indicator projector (DPF, DPR, and DPS)**
- 5.12.1. Luminous intensity and standard light distribution:**
- 5.12.1.1. The intensity of light emitted shall not exceed  $1.20 \cdot 10^4$  cd within the projection area as defined by the individual specifications of UN Regulation No. 48, when installed in any mounting position specified by the applicant.**
- 5.12.1.2. In addition, outside of the projection area as defined by the individual specifications of UN Regulation No. 48, one of the following conditions shall be fulfilled:**
- (a) The light emitted directly towards the side, the front or the rear of the vehicle shall not exceed  $5 \cdot 10^{-1}$  cd within the angular field as defined below:**
- (i) The vertical minimum angle  $\phi_{\min}$  (in degrees) is:  
 $\phi_{\min} = \arctan((1-h)/10)$ ; where h is mounting height in m**
- (ii) The vertical maximum angle  $\phi_{\max}$  (in degrees) is:  
 $\phi_{\max} = \phi_{\min} + 11.3$**
- The measurement shall be limited to a horizontal angle ranging from  $+90^\circ$  to  $-90^\circ$  with respect to the line which cuts the reference axis and which is perpendicular to the vertical transversal plane of the vehicle.**
- (b) When the apparent surfaces of the direction indicator projector and the apparent surface of the direction indicator lamp are arranged in such a way that**
- (i) Either the projection of the apparent surfaces in the direction of the reference axis of them occupies not less than 60 per cent of the smallest quadrilateral circumscribing the projections of the said apparent surfaces in the direction of the reference axis; or**
- (ii) The minimum distance between the facing edges of the apparent surfaces in the direction of the reference axis of them does not exceed 75 mm when measured perpendicularly to the reference axis,**
- the direction indicator projector shall be tested together with the direction indicator lamp and the integrated luminous intensity shall not exceed the maximum luminous intensity required in Table 8 of the relevant direction indicator lamp.**
- 5.12.1.3. To fulfil the requirement in paragraph 5.36.5. of UN Regulation No. 48, the luminous intensity of a direction indicator projector may be reduced to a maximum luminous intensity value not exceeding  $7.00 \cdot 10^3$  cd.**
- The related indication shall be made in the communication form in Annex 1.**
- 5.12.2. Minimum luminous intensity within the angles of geometric visibility**
- No requirement.**
- 5.12.3. Minimum or maximum area of apparent surface:**
- No requirement.**
- 5.12.4. Measurement:**
- No additional requirement.**
- 5.12.5. Additional specific requirements:**

The flash may be produced by sequential projection of basic elements if the following conditions are met:

- (a) Each projection of basic element, shall remain lit until the end of the ON cycle;
- (b) The sequence of basic elements projection shall produce a signal which proceeds in a uniform progressive manner from the area close to the vehicle to the area farther away from the vehicle within the projection area.
- (c) Each sequential projection cycle shall finish no more than 200 ms after the beginning of the ON cycle;

Compliance to the conditions mentioned above shall be verified in flashing mode.

5.12.6. Failure provisions:

No requirement.

5.12.7. Colour:

The colour of light emitted shall be amber.”

Annex 1,

Initial table, amend the list of lamps to read:

“

Lamp: <sup>2</sup>	Rear-registration plate illuminating lamp Direction indicator lamp Stop lamp Position lamp End-outline marker lamp Reversing lamp Manoeuvring lamp Rear fog lamp Parking lamp Daytime running lamp Side marker lamp <b>Direction indicator projector</b>
--------------------	---

”

Insert a new item 9.1.7. and related sub-items, to read:

“9.1.7. Direction indicator projector:

9.1.7.1. Front direction indicator projector:

9.1.7.1.1. Tested together with front direction indicator lamp: yes/no<sup>2</sup>

9.1.7.1.2. The luminous intensity of front direction indicator projector is intended to be reduced to not exceed  $7.00 \cdot 10^3$  cd: yes/no<sup>2</sup>

9.1.7.2. Rear direction indicator projector:

9.1.7.2.1. Tested together with rear direction indicator lamp: yes/no<sup>2</sup>

9.1.7.2.2. The luminous intensity of rear direction indicator projector is intended to be reduced to not exceed  $7.00 \cdot 10^3$  cd: yes/no<sup>2</sup>

9.1.7.3. Side direction indicator projector:

- 9.1.7.3.1. Tested together with side direction indicator lamp: **yes/no<sup>2</sup>**
- 9.1.7.3.2. The luminous intensity of side direction indicator projector is intended to be reduced to not exceed  $7.00 \cdot 10^3$  cd: **yes/no<sup>2a</sup>**

## II. Justification

### General

- This proposal intends to introduce the possibility of light-signalling, in form of projection of patterns on the road, for other road users through new light-signalling function “Direction indicator projection”.
- Concerning the Direction Indicator Projection, several studies have been done and have shown its effectiveness:
  - International Symposium on Automotive Lighting (ISAL) 2019: Requirement performance of Road Projection Lamp in Conjunction with Turn Signal Lamp (Koito, Shinshu university)
  - ISAL 2019: Visibility Improvement using Guide Function of Turn Signal Lamp, (Yeungnam University, SL Corporation, Hyundai Automotive)
  - SAE International 2020: Investigation on Safety Improvements by Lighting for Pedestrians and Cyclists (Audi AG)
  - ISAL 2023: Mock-up based Testing of Turn Signal Projection Lamps: Effects on Driver, Cyclist, and Pedestrian Safety (Yeungnam University)
  - ISAL 2023: Research on Alerting Effects of Road Projection of Direction Indicator to Cyclists (National Traffic Safety and Environment Laboratory, Koito)
- For example, under the following situations the direction indicator projection is very effective:

#### Front direction indicator projection

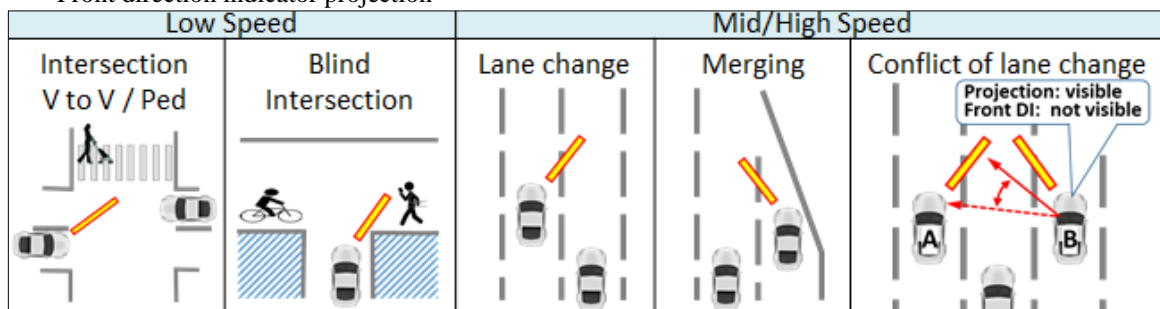

#### Front, Side, Rear direction indicator projection (blind spot avoidance)

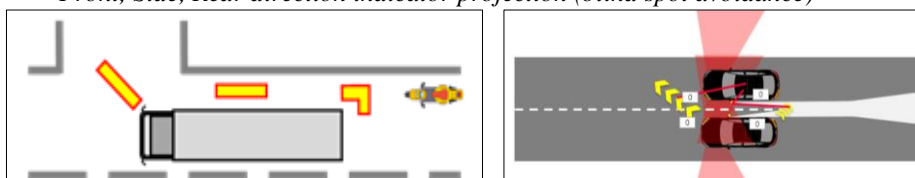

#### Relationship between Signal Road Projection and Signal Road Projector

- The direction indicator projection is an intentional projection onto the road surface for proving enhanced recognition of the direction indication signal. Therefore, it is proposed as a new light signalling function in UN Regulation No. 48 to ensure appropriate usage permissions and limitations.
- Complementary updates to UN Regulation No. 148 are also required, to ensure appropriate device performance permissions and limitations.

6. Any downwards directed light from existing light-signalling devices, that may also cause reflections from the road surface, is not regulated as direction indicator projection. It is not intended to change any existing requirements of direction indicators, as their performance is already known and regulated. This proposal allows the introduction of direction indicator projection as a supplement to the current regulations.

*Photometric requirement and test method of direction indicator projection*

7. Higher intensity of light on the road surface allows better recognition of a projected pattern. However, a maximum limit is required to prevent excessive reflections. To avoid creating unique limits, the existing limit of 12,000 cd for a front fog lamp of Category F3 is proposed as a maximum limit for direction indicator projection, as this is an already known value.

8. The direction indicator projector may be installed in any location of the vehicle if it is invisible to other road users. To confirm this, the same requirements as for other lamps defined as invisible (e.g. exterior courtesy lamp or manoeuvring lamp) shall apply. In this way, the direction indicator projector does not confuse other road users about the number of light-signalling devices.

9. Alternatively, it may be permitted for the direction indicator projector to be visible to other road users if its installation complies with the requirements of paragraph 5.7.2., single lamps. In this case, to ensure the compliance with the requirements of the corresponding lamp, the projector shall be tested in combination with the related light-signalling device as suggested in paragraph 5.12.1.2. (b).

*Projection area of Direction Indicator Projector*

10. As for the projection area, in UN Regulation No. 48 the appropriate and effective area is specified without causing discomfort, distraction or glare.

11. The requirements in paragraph 6.27.5. or 6.28.5. of UN Regulation No. 48 proposed in this document guarantee that observers are able to recognize the signal, to identify the correct relation between the direction indicator projector and a projecting vehicle and that the projection does not extend excessively beyond the vehicle.

12. Studies at Yeungnam University used test vehicles that produced projections that extended up to 2,157 mm from the extreme outer edge of the vehicle. However, following the demonstrations at the eighty-eighth session of the Working Party on Lighting and Light-Signalling (GRE) and discussions at its ninetieth session, to address concerns over excessive intrusion into adjacent lanes, the decision was made to reduce the distance allowed. Calculating from a typical lane of approximately 3,000 mm wide and a typical vehicle being 2,000 mm wide, the proposed value of 1,500 mm would mean intrusion is limited to 1,000 mm which is one third of the adjacent lane.

13. The result of the GTB internal research, comparing 5,000 mm and 2,000 mm pattern length, concluded that there is a visual recognition time difference, shorter by 1.08 sec at 10 km/h, in the case of the longer pattern. Therefore, the longitudinal distance from the farthest edge of the patterns on the road is proposed to be limited to 5,000 mm.

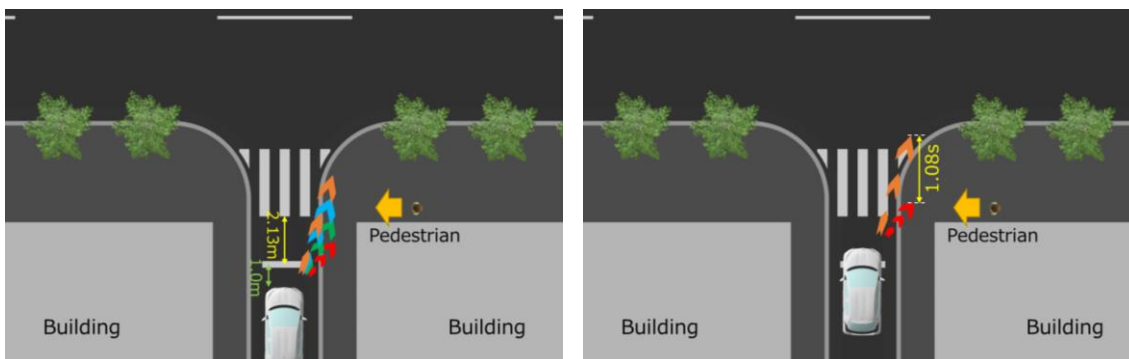

*Principle of the anti-glare restriction for projectors*

14. The projector might project into all areas of the projection zone with full intensity of 12,000 cd. Outside of the projection zone, the intensity is limited by the maximum intensity of the related light-signalling device when both the related light-signalling device and projector are switched ON.

*Basic element of Direction Indicator Projection pattern*

15. GTB defined basic elements of pattern that provide a clear information and cannot be confused with road signs/markings. The selected basic element for Direction Indicator Projection is a chevron (see Annex 17).

16. Several Signal Road Projection studies have been conducted during the past years considering different pattern elements, with similar positive results regarding visibility of the signal, comprehension of the driver's intention and perceived safety. Specifically, the selected chevron shape has been included in GTB internal and external research (ISAL, Société des Ingénieurs de l'Automobile (SIA) Vision Conference, SAE International, etc). Although the research objectives were not to evaluate the pattern shape, there was no negative opinion or result about the proposed pattern shapes. It means that the safety of the pattern shape has been proved by indirect way.

17. Chevron is proposed as the basic element of Direction Indicator projector because it is a proper shape for informing about the driver's intention of changing the direction of the vehicle.

18. The pattern shall be constituted with one or more basic element(s) of the same type in a line. However, the number, size, ratio and spacing between the basic elements in the pattern are not restricted if it meets the related projecting area requirements.

*Additional requirements for Direction indicator projection*

19. The discussions at the ninetieth session of GRE indicated that the perceive benefits of the function would not be the same at all situations and use cases. The two main scenarios that were recognised as most beneficial were urban slow speed turns into junctions and outside of urban area changing lanes on motorways. Therefore, to limit the scenarios and durations of projection function, two speed limit zones are proposed to focus the activation to the scenarios when the functionality is most beneficial. Urban slow speed turns into junctions still require the signal to be active for sufficient time to allow it to be seen by other users, especially cyclists. 40 km/h is chosen as the maximum limit, as this is aligned to maximum expected speed of cyclists / e-cyclists. Outside of urban area, changing lanes on motorways, 70 km/h is chosen as the lowest limit of this scenario, as this aligned to existing Class E switching conditions that correspond motorway conditions.

20. The front direction indicator projection is proposed to be only performed when the vehicle is in forward motion and the rear direction indicator projection is proposed to be only performed when the vehicle is in reversing motion. In the case that the pattern's horizontal angle to the median longitudinal plane of the vehicle exceeds 45°, the front direction indicator projection and the rear direction indicator projection can be switched ON, no matter of the moving direction of the vehicle. The reason is that the pattern in which the angle exceeds 45° is perceived by the other road users like directing sideward.

*Activation under adverse weather conditions*

21. Since Direction indicator projection could be used quite frequently and in many different situations, its activation is restricted under adverse weather conditions. If the windshield wiper is switched ON and its continuous operation has occurred for a period of at least two minutes, it is proposed either to switch the Direction Indicator projection OFF, or to reduce its luminous intensity at a value equal to or below  $7.00 \cdot 10^3$  cd. The chosen threshold refers to the maximum allowed luminous intensity of segment 10 and below for the adaptive front-lighting system (AFS) headlamp in adverse weather condition mode, as defined in UN Regulation No. 149, 01 series of amendments.