

29 July 2024

Agreement

Concerning the Adoption of Harmonized Technical United Nations Regulations for Wheeled Vehicles, Equipment and Parts which can be Fitted and/or be Used on Wheeled Vehicles and the Conditions for Reciprocal Recognition of Approvals Granted on the Basis of these United Nations Regulations*

(Revision 3, including the amendments which entered into force on 14 September 2017)

Addendum 128 – UN Regulation No. 129

Revision 4 - Amendment 11

04 series of amendments – Date of entry into force: 15 June 2024

Uniform provisions concerning the approval of Enhanced Child Restraint Systems used on board of motor vehicles (ECRS)

This document is meant purely as documentation tool. The authentic and legal binding text is: ECE/TRANS/WP.29/2023/109.



UNITED NATIONS

* Former titles of the Agreement:

Agreement concerning the Adoption of Uniform Conditions of Approval and Reciprocal Recognition of Approval for Motor Vehicle Equipment and Parts, done at Geneva on 20 March 1958 (original version); Agreement concerning the Adoption of Uniform Technical Prescriptions for Wheeled Vehicles, Equipment and Parts which can be Fitted and/or be Used on Wheeled Vehicles and the Conditions for Reciprocal Recognition of Approvals Granted on the Basis of these Prescriptions, done at Geneva on 5 October 1995 (Revision 2).

Reference to Consolidated Resolution on the Construction of Vehicles (R.E.3.), in all the text of the UN Regulation, amend to read:

"As defined in the Consolidated Resolution on the Construction of Vehicles (R.E.3.), document ECE/TRANS/WP.29/78/Rev.7, ... - <https://unece.org/transport/standards/transport/vehicle-regulations-wp29/resolutions>"

Paragraph 2.12., amend to read:

"2.12. "Anti-rotation device". Means a device intended to limit the rotation of the Enhanced Child Restraint System during a vehicle impact and in the case of i-Size ECRS consisting of:

- (a) A top-tether strap; or
- (b) A support-leg.

Meeting the requirements of this Regulation and fitted to an ISOFIX anchorage system and ISOFIX top tether anchorages or vehicle floor contact surface meeting the requirements of UN Regulation No. 14 or UN Regulation No. 145.

An "Anti-rotation device" for a "specific vehicle" Enhanced Child Restraint System may comprise a top tether, a support leg, lower tether strap(s) or, any other means capable of limiting the rotation."

Paragraph 2.14., amend to read:

"2.14. "Tension relieving device" means a system, which allows to release the device that adjusts and maintains the tension in the ISOFIX top tether strap or in the lower tether strap(s)."

Insert new paragraphs 2.63. to 2.63.6., to read:

"2.63. "Lower tether anchorage (LTA)" is an anchorage on the vehicle seat track, or on or close to the vehicle floor to which a lower tether bracket can be attached or is integrated. The lower tether bracket may or may not be part of the vehicle approval.

2.63.1. "Lower tether" is a type of anti-rotation device intended to restrict the rearward rotation of a rearward-facing ECRS.

2.63.2. "Lower tether strap" is a webbing strap (or equivalent) which extends from the back of a Specific Vehicle ECRS to the lower tether anchorage in the vehicle and which is equipped with an adjustment device, a tensioning-relieving device and a lower tether connector.

2.63.3. "Lower tether connector" means a device intended to be attached to a lower tether bracket.

2.63.4. "Lower tether hook" means a connector typically used to attach a lower tether strap to a lower tether bracket and which is the same and has the same dimensions as the ISOFIX top tether hook as defined in figure 3 of Annex 4 of UN Regulation 145.

2.63.5. "Lower tether bracket" means the bracket that is attached to or integrated with the lower tether anchorage.

2.63.6 "Generic lower tether bracket" means the bracket provided by the ECRS manufacturer together with the ECRS, to be attached under the rail of the front seat to the hole defined as LTA, indicated by the vehicle manufacturer."

Paragraph 3.2.2., amend to read:

"3.2.2. The applicant shall indicate the kind of application:

- (a) Application for an i-Size Enhanced Child Restraint Systems; or
- (b) Application for a specific vehicle ISOFIX Enhanced Child Restraint System; or

- (c) Application for a i-Size booster seat Enhanced Child Restraint System;
or
- (d) Application for a specific vehicle booster seat Enhanced Child Restraint System; or
- (e) Application for a Universal Belted Enhanced Child Restraint Systems;
or
- (f) Application for a Specific vehicle Belted Enhanced Child Restraint Systems; or
- (g) Application for a Universal booster cushion Enhanced Child Restraint System; or
- (h) Application for a Specific vehicle booster cushion Enhanced Child Restraint System; or
- (i) Any combination of (a), (b), (c), (d), (g) and (h) as long as they fulfil paragraphs 5.4.2.2., 6.1.2. and 6.1.3. provided there is only one belt route²; or
- (j) Any combination of (c), (d), (e), (f), (g) and (h) as long as they fulfil paragraphs 5.4.2.2., 6.1.2. and 6.1.3. provided there is only one belt route² and that the booster seat and booster cushion is not equipped with ISOFIX connectors."

Insert new paragraph 3.5., to read:

"3.5 an ECRS shall not bear more than one approval number. This provision does not apply for the purpose of approving a module as part of different ECRSs."

Insert new paragraph 4.6.4, to read:

"4.6.4. Only type-approved belt routings shall be indicated on the ECRS. The type-approved belt routings shall be green and no other colour. No other belt routings shall be indicated."

Paragraph 5.4.1.1., the reference to footnote ², renumber as footnote ³

Paragraph 6.1.3.6., the reference to footnote ³, renumber as footnote ⁴

Paragraph 6.3.5., the reference to footnote ⁴, renumber as footnote ⁵

Paragraph 7.2.4.3.4., the reference to footnote ⁵, renumber as footnote ⁶

Paragraph 4.14., amend to read:

"4.14. Additional markings

The following information may be conveyed by pictograms and/or text. The marking shall indicate:

...

- (c) The position and if necessary, the routing of top tethers, lower tethers, or other means of limiting Enhanced Child Restraint System rotation requiring action by the user, shall be indicated using one or more of the following symbols as appropriate:

² One belt route applies over the entire stature range regardless of the different configurations of use for which the ECRS will be approved: for an ECRS which allows forward and rearward facing orientation, only the one belt route shall be used for both configurations. The same applies for an ECRS which combines integral and non-integral configurations or any other combination that is allowed by this paragraph.

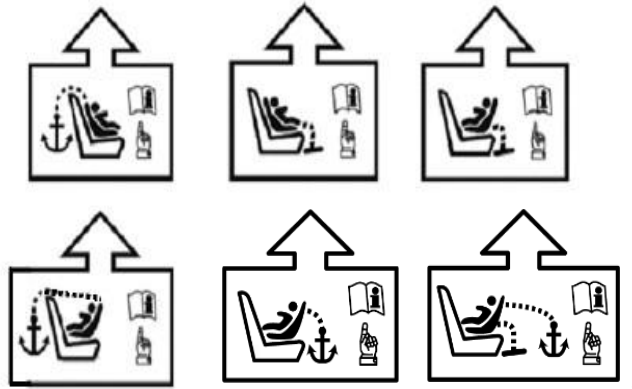

Paragraph 6.3.4.1., amend to read:

"6.3.4.1. Top tether connector
The top tether connector shall be an ISOFIX top tether hook as shown in Figure 3(c), or similar devices that fit within the envelope given by Figure 3(c). The same connector shall also be used as the lower tether hook (if applicable; see paragraph 6.3.6.)."

Insert new paragraph 6.3.4.2.1., to read:

"6.3.4.2.1. The ISOFIX top tether straps shall fulfil the requirements specified in paragraphs 6.7.4.2. to 6.7.4.4."

Paragraphs 6.3.4.2.1 to 6.3.4.2.2.(former), renumber as paragraphs 6.3.4.2.2 to 6.3.4.2.3.

paragraph 6.3.4.2.3.2., amend to read:

6.3.4.2.2. No-slack indicator
The ISOFIX top tether strap or the ISOFIX Enhanced Child Restraint System shall be equipped with a device that will indicate that all slack has been removed from the strap. The device may be part of an adjustment and tension relieving device and shall meet the requirements of paragraph 6.7.2."

Paragraph 6.3.4.2.3.(former), renumber as paragraph 6.3.4.2.4. and amend to read:

"6.3.4.2.4. Dimensions
Engagement dimensions for ISOFIX top tether hooks / lower tether hooks are shown in Figure 3(c).

...

Figure 3(c)

ISOFIX top tether or lower tether connector (hook type) dimensions....."

Paragraph 6.3.5., amend to read:

"6.3.5. Support leg and support leg foot requirements for i-Size ECRS and also for Specific Vehicle ECRS that are tested on the test bench according to paragraph 6.6.4.1.2.1

These support-legs shall comply in all positions of use (e.g. in case of length adjustable attachment, base, etc. the shortest and longest position) with the geometrical provisions defined in this paragraph and its subparagraphs.

..."

Insert new paragraphs 6.3.6. to 6.3.8., to read:

- "6.3.6. Specific vehicle belted Enhanced Child Restraint System lower tether strap specifications.
- 6.3.6.1. The lower tether straps shall fulfil the requirements specified in paragraphs 6.7.4.2. to 6.7.4.4.
- 6.3.6.2. Lower tether strap length
Enhanced Child Restraint System lower tether strap length shall be at least 900 mm including lower tether connector.
- 6.3.6.3. Lower tether no-slack indicator
The lower tether strap of the Enhanced Child Restraint System shall be equipped with a device that will indicate that all slack has been removed from the strap. The device may be part of an adjustment and tension relieving device and shall meet the requirements of paragraph 6.7.2.
- 6.3.6.4. Lower tether Retractor
An automatically locking retractor can be used to replace the provision for adjustment and release of the tension in the lower tether strap and the no slack indicator. In this case the retractor shall fulfil the requirements specified in paragraph 6.7.3.1.
- 6.3.6.5. Dimensions
Engagement dimensions for lower tether connectors (hook type) are shown in paragraph 6.3.4.2.4., Figure 3 (c).
- 6.3.7. Generic lower tether bracket and mounting material specifications (for applications where the vehicle manufacturer provides the generic anchorages).
- 6.3.7.1. The generic lower tether brackets supplied by the manufacturer of the child restraint, shall be accompanied by mounting instructions including required torque application and a note that this shall be done by qualified personnel only.
- 6.3.7.2. Dimensions bracket:
- (a) The generic lower tether bracket shall have dimensions according to Figure 3 (f);
 - (b) The outer edges of the lower tether bracket shall be at least blunted.

Figure 3 (f)
Generic Lower Tether Bracket

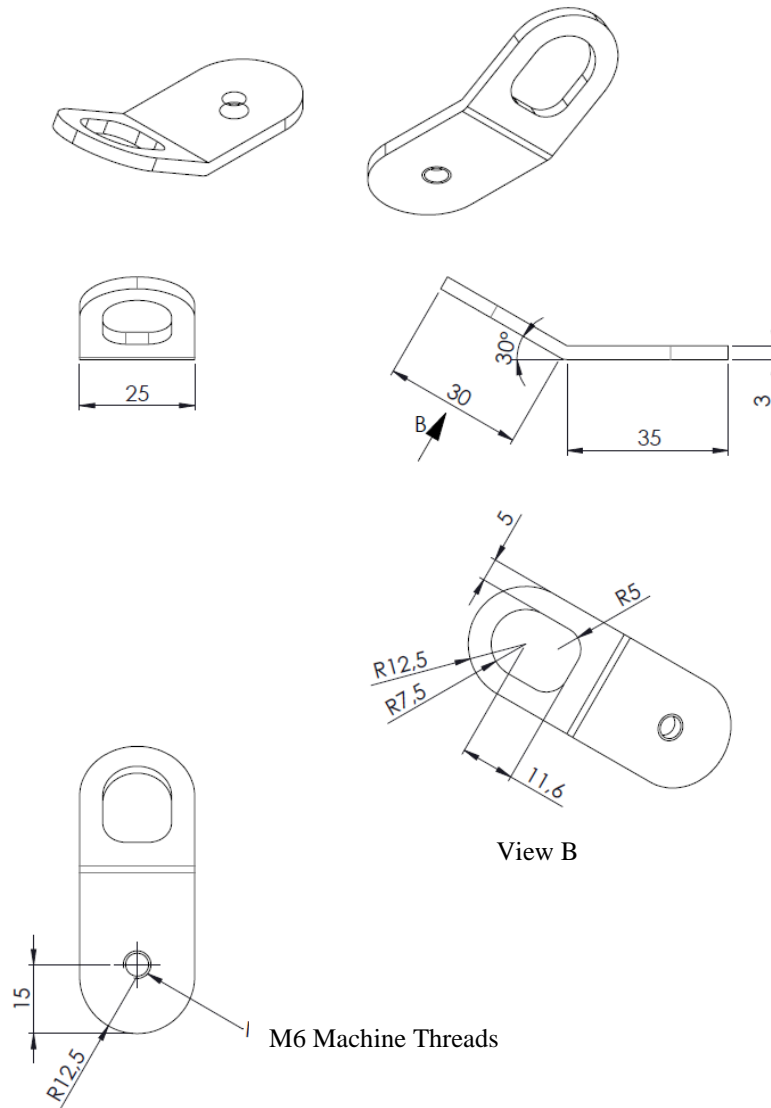

6.3.7.3. Mounting material bracket

The mounting material shall consist of:

- (a) M6x8 flange buttonhead hexagon socket-cap screw see figure 3 (g);
- (b) M6 washer; see figure 3 (h);
- (c) M6 -8 shoulder washer; see figure 3 (i).

Figure 3 (g)
M6x8 Flange Buttonhead Hexagon Socketcap Screw (ISO 7380-2)

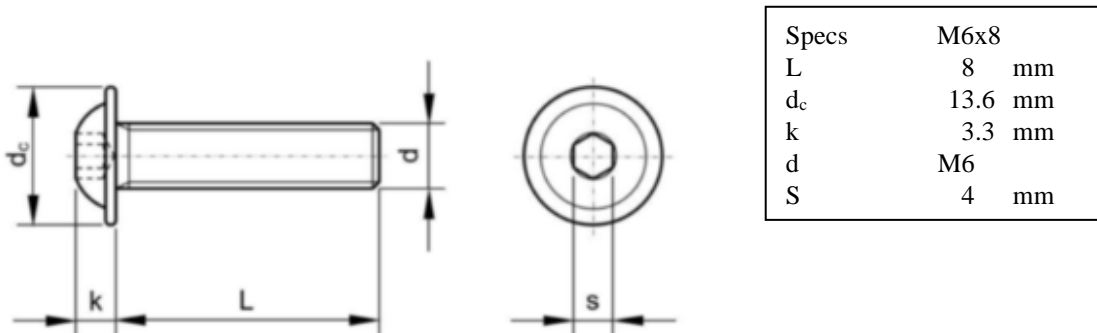

Figure 3 (h)
M6 washer

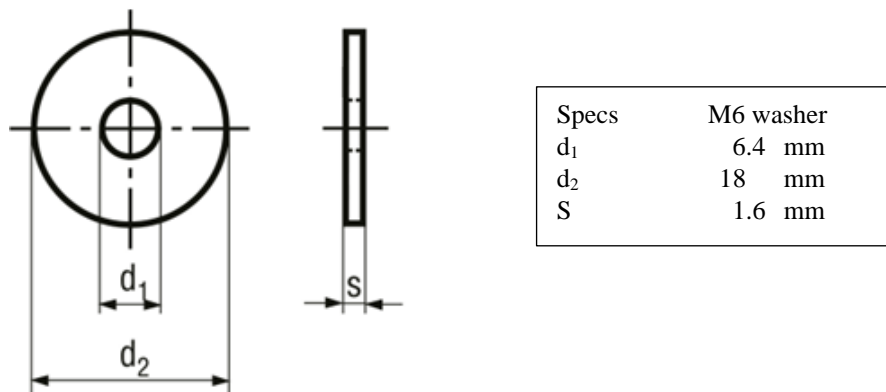
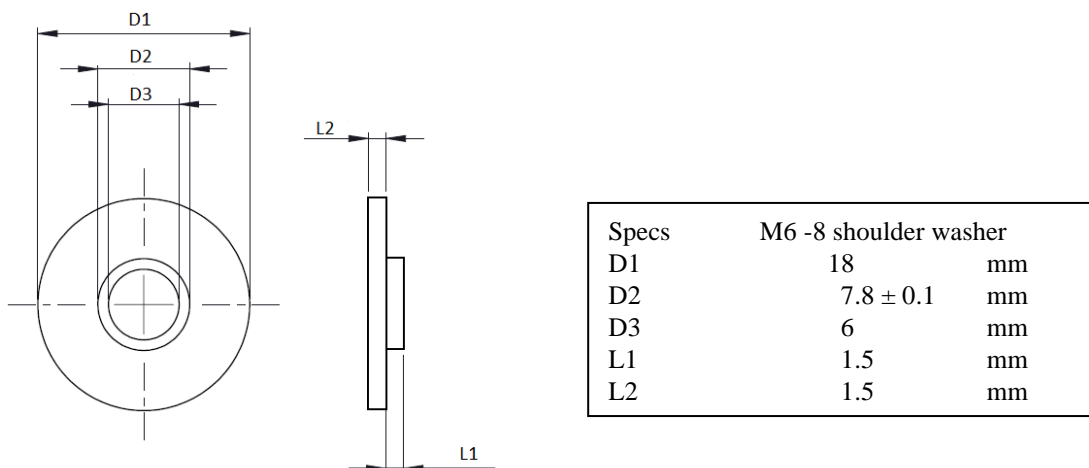

Figure 3 (i)
M6 -8 shoulder washer



6.3.8. Strength test generic lower tether bracket

6.3.8.1. Force application

Apply a force of 2,500 N ± 50 N to each generic lower tether bracket, by means of a representative lower tether strap 38 mm ± 3 mm wide that is fitted at one end with suitable hardware for applying the force and at the other end with a lower tether hook for the attachment to the lower tether bracket. For anchorages designed to be used for two adjacent CRS positions, or in case of a single LTA, the force shall be 5,000 N ± 100 N. At the request of the manufacturer the anchorages may be tested at higher loads as long as they fulfil the requirements.

6.3.8.2. Force direction

Two tests shall be performed; See figure 3 (j) and 3 (k)

(a) the force shall be applied in a direction of 55° ± 5° against plane AB, measured in a plane parallel to the rigid surface XY, and a direction of 45° ± 5° against the rigid surface XY, measured in plane AB; rotation around the anchorage point to vehicle (2) shall be prevented. see figure 3 (j);

(b) the force shall be applied in a direction perpendicular (90 ± 5°) to the rigid surface XY.

Figure 3 (j)
Test 1

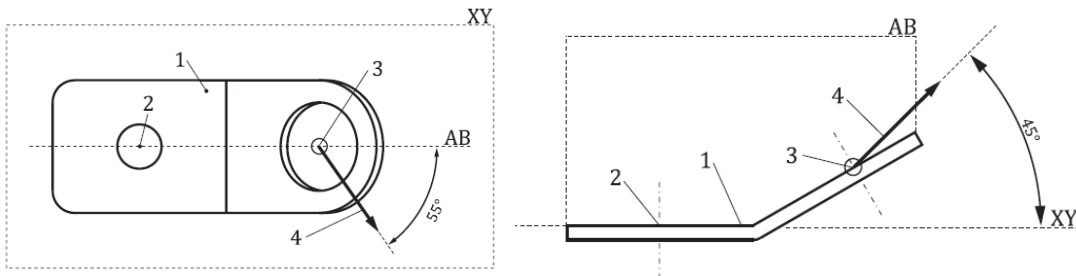

- Key:
1. generic lower tether bracket (not actual design).
 2. anchorage point to vehicle.
 3. anchorage point lower tether hook.
 4. test 1 - force direction.
 5. the XY plane is located on top of the bracket (thus loading the thread inside the bracket)

Figure 3 (k)
Test 2

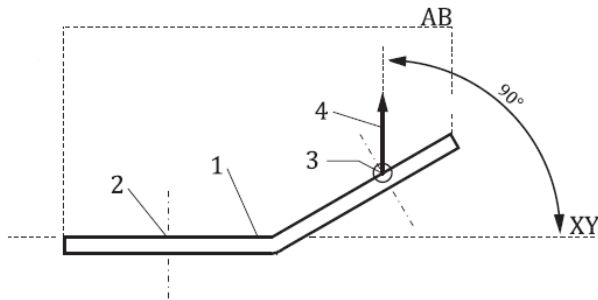

- Key:
1. generic lower tether bracket (not actual design).
 2. anchorage point to vehicle.
 3. anchorage point lower tether hook.
 4. test 2 – force direction.
 5. the XY plane is located on top of the bracket (thus loading the thread inside the bracket)

6.3.8.3. The load shall be attained within 30 s, and shall be maintained for a minimum of 0.2 s.

6.3.8.4. When testing in accordance with paragraphs 6.3.8.1. to 6.3.8.3., excursion is not limited, and permanent deformation of the generic lower tether bracket with respect to the rigid structure it is attached to is acceptable provided that the anchorage does not break or separate from the rigid structure."

Paragraph 6.6.4.4.1.2.1., amend to read:

"6.6.4.4.1.2.1. Head excursion: no part of the head of the dummy shall pass beyond the planes

...

Where a test is conducted with paragraphs 6.6.4.1.6.1.1. or paragraph 6.6.4.1.6.1.2. or paragraph 6.6.4.1.8.2. above, only the second test results without 100 mm diameter bar will be considered. A tolerance of +10 per cent shall be applied to the head excursion value distance between the Cr point and plane DF, and the dummy should not pass beyond the plane HI, parallel to plane DE."

Figure 5, amend to read:

"Figure 5

Test Arrangement for a Rearward-Facing Device, not supported by the dashboard

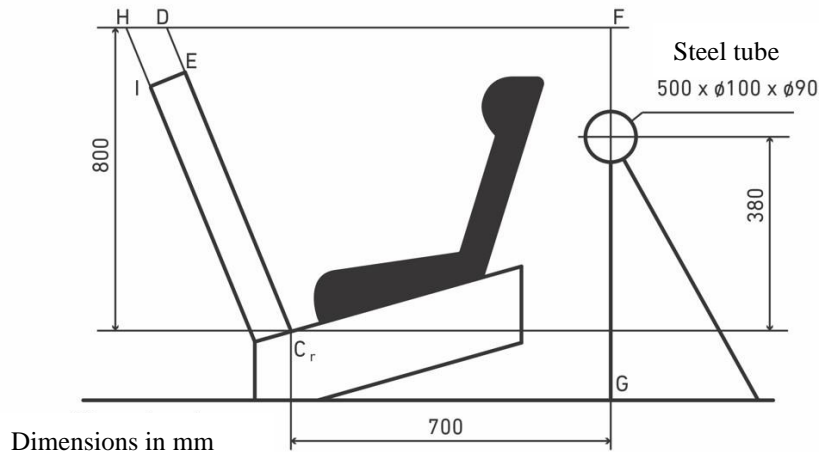

Paragraph 6.7.4.3.2., amend to read:

"6.7.4.3.2. In addition, the breaking load shall be not less than 3.6 kN for the restraints of Enhanced Child Restraint Systems."

Paragraph 7.1.3.5.2.3., amend to read:

"7.1.3.5.2.3. Installation of an Integral Enhanced Child Restraint Systems "Universal Belted" Seat or Specific Vehicle Belted Seat on the Test Bench

...

Extract all webbing from the retractor spool and rewind the excess webbing keeping a tension of $4 \pm 3\text{N}$ in the belt between the retractor and the pillar loop. The spool shall be locked before the dynamic test.

If present, the top tether or lower tether shall be adjusted to achieve a tension load of $50 \pm 5\text{N}$. Alternatively, and if present, the support-leg shall be adjusted according to the enhanced child restraint system manufacturer's instructions.

If present, the lower tether bracket(s) shall be mounted on the positions in accordance with annex 6, appendix 2, figure 5. The installation of the bracket(s) shall be in accordance with the user manual.

The dummy shall be placed in the Enhanced Child Restraint System separate from the seat-back of the chair by a flexible spacer.

..."

Insert new paragraphs 16.13. to 16.15., to read:

"16.13. As from 1 September 2026, Contracting Parties applying this Regulation shall not be obliged to accept UN type-approvals to the preceding series of amendments, first issued after 1 September 2026.

16.14. As from 1 September 2027, Contracting Parties applying this Regulation shall not be obliged to accept type-approvals issued to the preceding series of amendments to this Regulation.

- 16.15. Notwithstanding paragraphs 16.13 and 16.14, Contracting Parties applying the UN Regulation shall continue to accept, and grant extensions to, UN type-approvals issued according to the preceding series of amendments to the UN Regulation, for the Enhanced Child Restraint Systems which are not affected by the changes introduced by the 04 series of amendments."

Annex 2, amend to read:

"Annex 2

1. Arrangements of the Approval Mark

..."

Replace "03" by "04" series of amendments throughout the text.

Annex 6, Appendix 2, amend to read:

"Annex 6 - Appendix 2

Arrangement and Use of Anchorages on the Test Trolley

1. The anchorages shall be positioned as shown in the Figure below.
2. Enhanced Child Restraint Systems in the i-Size universal, specific and restricted categories shall use the following anchorage points: H₁ and H₂.
3. For testing of Enhanced Child Restraint Systems with top tether, the anchorage G₁ or G₂ shall be used.
4. In the case of Enhanced Child Restraint Systems utilising a support-leg, the Technical Service shall select the anchorages to be used according to paragraph 3. above and with the support-leg adjusted as specified in paragraph 7.1.3.6.3. of this Regulation.
5. For the testing of Enhanced Child Restraint Systems with lower tether(s), the floor shall be placed in its lowest position. LTA 4 is to be used in case the top tether anchorage from the seat in front is used. Otherwise LTA 2 and LTA 3; see figure 5. Generic lower tether brackets to be used for the dynamic test in case they are provided by the CRS manufacturer.
6. The structure carrying the anchorages shall be rigid. The upper anchorages shall not be displaced by more than 0.2 mm in the longitudinal direction when a load of 980 N is applied to them in that direction. The trolley shall be so constructed that no permanent deformation shall occur in the parts bearing the anchorages during the test."

Annex 6, Appendix 2, figure 5, amend to read:

"Figure 5

**Top View – Bench with Lower Tether Anchorages
(LTA 1, LTA 2, LTA 3 and LTA 4)**

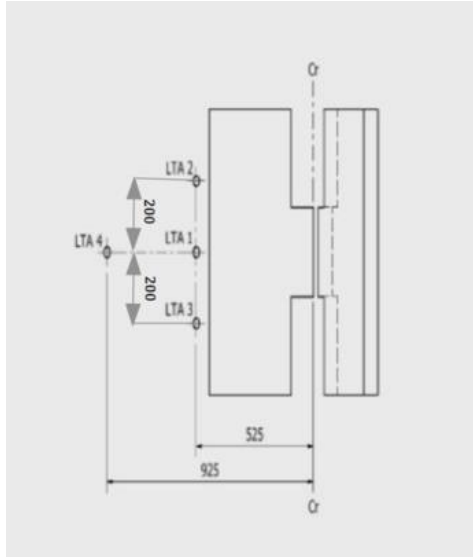

Dimensions in mm; Tolerance general: +/- 2 mm."

Annex 24, amend to read:

"Annex 24

**Additional Attachment points Required for Securing
Rearward Facing Enhanced Child Restraint System, of the
Category Specific Vehicle Belted, to Motor Vehicles**

1. This annex applies only to the additional anchorages for attaching Enhanced Child Restraint in the Specific vehicle Belted category or to bars or other special items used to secure child-restraining devices to the bodywork, whether or not they make use of UN Regulation No. 14 or UN Regulation No. 145, on ISOFIX anchorage systems, ISOFIX top tether anchorages, lower tether anchorages and i-Size seating positions.
2. The manufacturer of the child restraint system shall describe how the child restraint system attaches to different vehicles and shall submit this to the Technical Service conducting the tests for its assessment.

The manufacturer of the child restraint system shall consult the information supplied by the vehicle manufacturer, as supplied according to UN Regulation No. 16, Annex 17, Appendix 3 and/or the vehicle handbook, e.g. with regard to allowing the use of additional anchorages and a support leg before inclusion of the vehicle type in the vehicle list.

The Technical Services may consider information obtained from the vehicle manufacturer.
3. The manufacturer of the child restraint shall provide the necessary parts for fitting the generic lower tether brackets (if any) and a special plan for each vehicle showing their exact location."

Annex 27, amend to read:

"Annex 27

List of Minimum Contents for the Test Reports included in the Type Approval Application

This annex contains a list of the minimum content and information that shall be provided in the test reports that are included in the Type Approval Application. How this information is presented in the Type Approval Application shall be the choice of the Technical Service, i.e. the layout, format, order of the information may be changed.

ECRS Description

	ECRS Category (3.2.2.)	Stature Range	Orientation	Attachment
Category 1				
Category 2				
Category 3				
.....				
...				
6.3.3.	<i>ISOFIX attachments</i>			
6.3.3.2.	Dimensions			
6.3.3.3.	Partial latching indication			
6.3.3.3.	The ISOFIX Enhanced Child Restraint System shall incorporate means by which there is a clear indication that both of the ISOFIX attachments are completely latched with the corresponding ISOFIX lower anchorages.		latch indicator	[Y/N]
6.3.3.3.	The indication means may be audible,		check	[Y/N]
6.3.3.3.	tactile or		check	[Y/N]
6.3.3.3.	visual or		check	[Y/N]
6.3.3.3.	a combination of two or more.		check	[Y/N]
6.3.3.3.	In case of visual indication, it shall be detectable under all normal lighting conditions.		check	[Y/N]
6.3.4.	ISOFIX Enhanced Child Restraint System top tether strap specifications			
6.3.4.1.	Top tether connector			
6.3.4.1.	The top tether connector shall be ISOFIX top tether hook as shown in Figure 3(c), or similar devices that fit within the envelope given by Figure 3(c).			[Y/N]

	Figure 3(c): ISOFIX top tether or lower tether connector (hook type) dimensions		
6.3.4.2.	ISOFIX top tether strap features		
6.3.4.2.	The ISOFIX top tether strap shall be supported by webbing (or its equivalent), having a provision for adjustment and release of tension.	check	[Y/N]
6.3.4.2.1.	The ISOFIX top tether straps shall fulfil the requirements specified in paragraphs 6.7.4.2. to 6.7.4.4.		[pass/ fail]
6.3.4.2.2.	ISOFIX Top tether strap length ISOFIX Enhanced Child Restraint System top tether strap length shall be at least 2,000 mm.	TT strap length [mm]	
6.3.4.2.3.	No-slack indicator The ISOFIX top tether strap or the ISOFIX Enhanced Child Restraint System shall be equipped with a device that will indicate that all slack has been removed from the strap. The device may be part of an adjustment and tension relieving device.	check	[Y/N]
6.3.4.2.4.	Dimensions Engagement dimensions for ISOFIX top tether hooks are shown in Figure 3(c).	check	

Insert new paragraphs 6.3.6. to 6.3.8., to read:

6.3.6.	<i>Lower tether strap specifications</i>		
6.3.6.1.	The lower tether straps shall fulfil the requirements specified in paragraphs 6.7.4.2. to 6.7.4.4.		[pass/ fail]
6.3.6.2.	Lower tether strap length: Enhanced Child Restraint System lower tether strap length shall be at least 900 mm including lower tether connector.	LT strap length [mm]	
6.3.6.3.	Lower Tether No-slack indicator: The lower tether strap or the Enhanced Child Restraint System shall be equipped with a device that will indicate that all slack has been removed from the strap. The device may be part of an adjustment and tension relieving device.	check	[Y/N]
6.3.6.4.	Lower tether Retractor: An automatically locking retractor can be used to replace the provision for adjustment and release of the tension in the lower tether strap and the no slack indicator. In this case the retractor shall fulfil the requirements specified in paragraph 6.7.3.1.	check	[Y/N] [pass/ fail]
6.3.6.5.	Dimensions Engagement dimensions for lower tether hooks are shown in paragraph 6.3.4.2.4., Figure 3(c).	check	

6.3.7. <i>Generic lower tether bracket specifications</i>			
6.3.7.1.	The generic lower tether brackets supplied by the manufacturer of the child restraint, shall be accompanied by mounting instructions including required torque application and a note that this shall be done by qualified personnel only.	Torque [Nm]	[pass/ fail] ...
6.3.7.2.	Dimensions bracket:		
	(a) the generic lower tether bracket shall have dimensions according to Figure 3 (f);	check	
	(b) the outer edges of the lower tether bracket shall be at least blunted.	check	
6.3.7.3.	mounting material bracket the mounting material consists of:		
	(a) M6x8 flange buttonhead hexagon socketcap screw; see figure 3 (g);	check	
	(b) M6 washer; see figure 3 (h);	check	
	(c) M6 -8 shoulder washer; see figure 3 (i).	check	
6.3.8. <i>Generic lower tether bracket strength test</i>			
6.3.8.1.	Force application	Measured force	
	Apply a force of 2,500 N to each generic lower tether bracket, by means of a representative lower tether strap 38 mm ± 3 mm wide that is fitted at one end with suitable hardware for applying the force and at the other end with a lower tether hook for the attachment to the lower tether bracket. For anchorages designed to be used for two adjacent CRS positions, or in case of a single LTA, the force shall be 5,000 N.	[N]	
6.3.8.2.	Force direction		
	Two tests are performed; See figure 3 (j) and 3 (k):	check	[pass/ fail]
	(a) The force shall be applied in a direction of 55° ± 5° against plane AB, measured in a plane parallel to the rigid surface XY, and a direction of 45° ± 5° against the rigid surface XY, measured in plane AB; see figure 3 (j);		
	(b) The force shall be applied in a direction perpendicular (90 ± 5°) to the rigid surface XY.		
6.3.8.3.	The load shall be attained within 30 s, and shall be maintained for a minimum of 0.2 s.	check	[pass/ fail]

6.3.8.4.	When testing in accordance with paragraphs 6.3.8.1. to 6.3.8.3., excursion is not limited, and permanent deformation of the generic lower tether bracket with respect to the rigid structure it is attached to is acceptable provided that the anchorage does not break or separate from the rigid structure.	check	[pass/ fail]
----------	---	-------	-----------------

...

* The measurement procedures shall follow those of ISO 6487 with SAE J211 sign convention."
