



Economic Commission for Europe**Inland Transport Committee****World Forum for Harmonization of Vehicle Regulations****Working Party on Pollution and Energy****Ninety-first session**

Geneva, 14–16 October 2024

Item 5 of the provisional agenda

UN Regulations Nos. 24 (Visible pollutants, measurement of power of C.I. engines (Diesel smoke)), 85 (Measurement of the net power), 115 (LPG and CNG retrofit systems), 133 (Recyclability of motor vehicles) and 143 (Heavy Duty Dual-Fuel Engine Retrofit Systems (HDDF-ERS))**Proposal for a new UN Regulation No. XXX on the determination of system power of hybrid electric vehicles and of pure electric vehicles having more than one electric machine for propulsion****Submitted by the experts from the International Organization of Motor Vehicle Manufacturers***

The text reproduced below was prepared by the experts from OICA and is intended to transpose the content of UN GTR No. 21 into a new UN Regulation of the 1958 Agreement.

* In accordance with the programme of work of the Inland Transport Committee for 2024 as outlined in proposed programme budget for 2024 (A/78/6 (Sect. 20), table 20.5), the World Forum will develop, harmonize and update UN Regulations in order to enhance the performance of vehicles. The present document is submitted in conformity with that mandate.

I. Proposal

UN Regulation No. XXX

On the determination of system power of hybrid electric vehicles and of pure electric vehicles having more than one electric machine for propulsion

Contents

	<i>Page</i>
1. Scope and application.....	3
2. Definitions.....	3
3. Abbreviations	6
4. Application for approval	6
5. Approval	7
6. Markings	7
7. Test conditions	8
8. Test procedure.....	11
9. General	26
10. Conformity of production.....	27
11. Penalties for non-conformity of production	27
12. Production definitively discontinued.....	27
Annexes	
1 Communication.....	30
Appendix 1 - Vehicle characteristics and information concerning the conduct of tests.....	32
Appendix 2 – Test Report	37
2 Arrangements of the approval mark.....	40
3 Identification of power determination reference points	41
4 Determination of speed of maximum power.....	46

1. Scope and application

- 1.1. This Regulation applies to vehicles that meet all of the following criteria (a), (b) and (c):
- (a) Are hybrid electric vehicles, or are pure electric vehicles that have more than one propulsion energy converter;
- and
- (b) Are classified in category N₁, or are classified in category M and have a technically permissible maximum laden mass not exceeding 3,500 kg;
- and
- (c) If a hybrid electric vehicle, at least one electric machine contributes to propulsion of the vehicle under the maximum power condition.
- 1.2. This Regulation does not apply to fuel cell vehicles.
- 1.3. When determined according to the requirements of this Regulation, the resulting vehicle system power rating may be considered as comparable to the power rating traditionally assigned to conventional vehicles, which is the power rating of the internal combustion engine.
- 1.4. The following document(s) are referenced in such a way that some or all of their content constitutes requirements of this document. The latest edition of the referenced document(s) (including any amendments) applies:
- ISO 1585:1992, Road vehicles – engine test code – Net power
- UN Regulation No. 85 — Uniform provisions concerning the approval of internal combustion engines or electric drive trains intended for the propulsion of motor vehicles of categories M and N with regard to the measurement of net power and the maximum 30 minutes power of electric drive trains.

2. Definitions

For the purposes of this Regulation,

- 2.1. "*Vehicle type with regard system power*" means a group of vehicles which do not differ with respect to the criteria as defined in paragraph 9.2..
- 2.1.1. Road load and dynamometer setting
- 2.1.1.2. "*Technically permissible maximum laden mass*" means the maximum mass allocated to a vehicle on the basis of its construction features and its design performances.
- 2.1.1.3. "*Fixed speed mode*" means the operating mode of the dynamometer in which the dynamometer absorbs the power output of the vehicle so as to maintain the vehicle at a fixed dynamometer speed.
- 2.1.3. "*Road load mode*" means the operating mode of the dynamometer in which the dynamometer exerts on the vehicle a force equivalent to the force exerted on the vehicle while driving on a road.
- 2.2. Powertrain
- 2.2.1. "*Powertrain*" means the total combination in a vehicle of propulsion energy storage system(s), propulsion energy converter(s) and the drivetrain(s) providing the mechanical energy at the wheels for the purpose of vehicle propulsion, plus peripheral devices.
- 2.2.2. "*Peripheral devices*" means energy consuming, converting, storing or supplying devices, where the energy is not primarily used for the purpose of

- vehicle propulsion, or other parts, systems and control units, which are essential to the operation of the powertrain.
- 2.2.3. "*Auxiliary devices*" means energy consuming, converting, storing or supplying non-peripheral devices or systems which are installed in the vehicle for purposes other than the propulsion of the vehicle and are therefore not considered to be part of the powertrain.
- 2.2.4. "*Drivetrain*" means the connected elements of the powertrain for transmission of the mechanical energy between the propulsion energy converter(s) and the wheels.
- 2.3. Electrified vehicles
- 2.3.1. "*Energy converter*" means a system where the form of energy output is different from the form of energy input.
- 2.3.2. "*Propulsion energy converter*" means an energy converter of the powertrain which is not a peripheral device whose output energy is used directly or indirectly for the purpose of vehicle propulsion.
- 2.3.3. "*Charge-depleting operating condition*" means an operating condition in which the energy stored in the REESS may fluctuate but decreases on average while the vehicle is driven until transition to charge-sustaining operation.
- 2.3.4. "*Charge-sustaining operating condition*" means an operating condition in which the energy stored in the REESS may fluctuate but, on average, is maintained at a neutral charging balance level while the vehicle is driven.
- 2.3.5. "*Category of propulsion energy converter*" means (i) an internal combustion engine, or (ii) an electric machine, or (iii) a fuel cell.
- 2.3.6. "*Energy storage system*" means a system which stores energy and releases it in the same form as was input.
- 2.3.7. "*Propulsion energy storage system*" means an energy storage system of the powertrain which is not a peripheral device and whose output energy is used directly or indirectly for the purpose of vehicle propulsion.
- 2.3.8. "*Category of propulsion energy storage system*" means (i) a fuel storage system, or (ii) a rechargeable electric energy storage system, or (iii) a rechargeable mechanical energy storage system.
- 2.3.9. "*Form of energy*" means (i) electrical energy, or (ii) mechanical energy, or (iii) chemical energy (including fuels).
- 2.3.10. "*Fuel storage system*" means a propulsion energy storage system that stores chemical energy as liquid or gaseous fuel.
- 2.3.11. "*Electric machine*" means an energy converter transforming between electrical and mechanical energy.
- 2.3.12. "*Off-vehicle charging hybrid electric vehicle*" (OVC-HEV) means a hybrid electric vehicle that can be charged from an external source.
- 2.3.13. "*Not off-vehicle charging hybrid electric vehicle*" (NOVC-HEV) means a hybrid electric vehicle that cannot be charged from an external source.
- 2.3.14. "*Hybrid vehicle*" means a vehicle equipped with a powertrain containing at least two different categories of propulsion energy converters and at least two different categories of propulsion energy storage systems.
- 2.3.15. "*Hybrid electric vehicle*" means a hybrid vehicle equipped with a powertrain containing at least one electric motor or electric motor-generator and at least one internal combustion engine as propulsion energy converter.
- 2.3.16. "*Pure electric vehicle*" (PEV) means a vehicle equipped with a powertrain containing exclusively electric machines as propulsion energy converters and

- exclusively rechargeable electric energy storage systems as propulsion energy storage systems.
- 2.3.17. "*Rechargeable electrical energy storage system*" (REESS) means a propulsion energy storage system that stores electrical energy and which is rechargeable. A battery whose primary use is to supply power for starting the engine and/or lighting and/or other vehicle auxiliaries systems is not considered as a REESS. The REESS may include the necessary ancillary systems for physical support, thermal management, electronic controls and casing.
- 2.3.18. "*State of charge*" (SOC) means the available electrical charge in a REESS expressed as a percentage of its rated capacity.
- 2.4. General
- 2.4.1. "*Driver-selectable mode*" means a distinct driver-selectable condition which could affect emissions, or fuel and/or energy consumption, or maximum system power output.
- 2.5. System power determination
- 2.5.1. "*Test procedure 1*" (TP1) means a test procedure, defined herein, for determining a vehicle system power rating via measured electrical power and determined ICE power.
- 2.5.2. "*Test procedure 2*" (TP2) means a test procedure, defined herein, for determining a vehicle system power rating via measured torque and speed at the axles or wheel hubs.
- 2.5.3. "*Power determination reference point*" (or simply "reference point") means a point in the mechanical power flow path of a powertrain where any portion of the mechanical energy that drives the wheels under the maximum power condition is first produced as mechanical energy by a propulsion energy converter from a propulsion energy storage system.
- 2.5.4. "*Power-rating mode*" means the driver-selectable mode (if any) for which a vehicle system power rating is desired.
- 2.5.5. "*Speed of maximum power*" means the fixed speed setting of the dynamometer at which a maximum accelerator pedal command, given for a period of at least ten seconds while the vehicle is in power-rating mode, delivers the greatest peak power to the dynamometer.
- 2.5.6. "*Maximum power condition*" means the condition in which the vehicle is operating on a dynamometer, the vehicle is in power-rating mode, the dynamometer is operating in fixed speed mode set to the speed of maximum power, and the maximum accelerator pedal command is given for a period of at least ten seconds.
- 2.5.7. "*Vehicle system power rating*" means the total power transmitted through all of the power determination reference point(s) as determined by TP1 or TP2.
- 2.5.8. "*Mechanical energy path*" means a distinct parallel path within a drivetrain that conducts a portion of the total mechanical energy passing through the drivetrain.
- [2.5.9. "*Peak system power*" means the maximum value of a 2-second moving average of the total power over a 10 second window beginning at the start of maximum accelerator command measured at Maximum power condition.
- 2.5.10. "*Sustained system power*" means is the average total power between the 8th and 10th seconds measured at Maximum power condition.
- 2.5.11. "*Total power*" refers to the combined power output from all power sources.]
- 2.6. System bench

- 2.6.1. "*System bench*" means a simulated vehicle powertrain on a test bench, which is a combination of the propulsion energy storage system(s), propulsion energy converter(s) and the drivetrain(s) providing the mechanical energy at the wheels for the purpose of vehicle propulsion, plus peripheral devices.
- 2.6.2. "*Simulators*" means a virtual model that is a software reproduction of some of the powertrain elements. Simulators may be used as part of the system bench.
- 2.6.3. "*Peripheral devices*" means supplying devices, where the energy is not primarily used for the purpose of vehicle propulsion, or other parts, systems and control units, which are essential to the operation of the powertrain. In addition, if the functions equivalent to the actual vehicle are satisfied, the equipment specifications may be substituted.

3. Abbreviations

General abbreviations

AWD	all-wheel drive
FSD	Full scale deflection
HEV	hybrid-electric vehicle
ICE	internal combustion engine
ICEV	internal combustion engine vehicle
ISO	International Organization for Standardization
REESS	rechargeable electric energy storage system
SOC	state of charge
UN	United Nations
TP1	Test procedure 1
TP2	Test procedure 2
OVC-HEV	Off-vehicle charging hybrid electric vehicle
NOVC-HEV	Not off-vehicle charging hybrid electric vehicle
PEV	Pure electric vehicle

4. Application for approval

- 4.1. The application for approval of a vehicle type with regard to the requirements of this Regulation shall be submitted by the vehicle manufacturer or by their authorized representative, who is any natural or legal person who is duly appointed by the manufacturer to represent him before the approval Authority and to act on his behalf in matters covered by this Regulation.
- 4.1.1. The application referred to in paragraph 4.1. shall be drawn up in accordance with the model of the information document set out in Annex 1 to this Regulation.
- 4.2. An appropriate number of vehicles representative of the vehicle type to be approved shall be submitted to the Technical Service responsible for the approval tests.
- 4.3. Changes to the make of a system, component or separate technical unit that occur after a type-approval shall not automatically invalidate a type-approval, unless its original characteristics or technical parameters are changed in such a way that the system power of the vehicle is adversely affected.

5. Approval

- 5.1. If the vehicle type submitted for approval meets all the relevant requirements of this Regulation, approval of that vehicle type shall be granted.
- 5.2. An approval number shall be assigned to each type approved.
- 5.2.1. The type-approval number shall consist of four sections. Each section shall be separated by the '*' character.
- Section 1: The capital letter 'E' followed by the distinguishing number of the Contracting Party which has granted the type-approval.
- Section 2: The number [of this Regulation,] followed by the letter 'R', successively followed by:
- (a) Two digits (with leading zeros as applicable) indicating the series of amendments incorporating the technical provisions of the UN Regulation applied to the approval (00 for the UN Regulation in its original form);
- (b) A slash (/) and two digits (with leading zeros as applicable) indicating the number of supplements to the series of amendments applied to the approval (00 for the series of amendments in its original form);
- Section 3: A four-digit sequential number (with leading zeros as applicable). The sequence shall start from 0001.
- Section 4: A two-digit sequential number (with leading zeros if applicable) to denote the extension. The sequence shall start from 00.
- All digits shall be Arabic digits.
- 5.2.2. Example of an Approval Number to this Regulation:
E11*[XXX]R01/00*0123*01
The first extension of the Approval numbered 0123, issued by the United Kingdom to Series of Amendments 01.
- 5.2.3. The same Contracting Party shall not assign the same number to another vehicle type.
- 5.3. Notice of approval or of extension or refusal of approval of a vehicle type pursuant to this Regulation shall be communicated to the Contracting Parties to the 1958 Agreement which apply this Regulation by means of a form conforming to the model in Annex 1 to this Regulation.

6. Markings

- 6.1. There shall be affixed, conspicuously and in a readily accessible place specified on the approval form, to every vehicle conforming to a vehicle type approved under this Regulation, an international approval mark consisting of:
- 6.1.1. A circle surrounding the letter "E" followed by the distinguishing number of the country that has granted approval¹.
- 6.1.2. The number of this Regulation, followed by the letter "R", a dash and the approval number to the right of the circle described in paragraph 5.4.1.

¹ The distinguishing numbers of the Contracting Parties to the 1958 Agreement are reproduced in Annex 3 to the Consolidated Resolution on the Construction of Vehicles (R.E.3), document ECE/TRANS/WP.29/78/Rev.6 – Annex 3, <https://unece.org/transport/standards/transport/vehicle-regulations-wp29/resolutions>.

- 6.2. If the vehicle conforms to a vehicle type approved, under one or more other Regulations annexed to the 1958 Agreement, in the country which has granted approval under this Regulation, the symbol prescribed in paragraph 5.4.1. need not be repeated; in such a case, the Regulation, approval numbers and the additional symbols of all the Regulations under which approval has been granted in the country which has granted approval under this Regulation shall be placed in vertical columns to the right of the symbol prescribed in paragraph 5.4.1.
- 6.3. The approval mark shall be clearly legible and be indelible.
- 6.4. The approval mark shall be placed close to or on the vehicle data plate.
- 6.4.1. Annex 2 to this Regulation gives examples of arrangements of the approval mark.

7. Test conditions

7.1. Test instrumentation

7.1.1. Dynamometer

The power absorption capacity of the dynamometer in fixed speed control mode shall be sufficient for the maximum power of the vehicle. Due to the short duration of maximum power under the test procedure (approximately 10 seconds), a short duration power rating of the dynamometer may be applicable to this requirement with approval of the Type-Approval Authority.

7.1.2. Test room

The test room shall have a temperature set point of 25 °C. The tolerance of the actual value shall be within $[\pm 5 \text{ °C}]$. At the request of the manufacturer, the 25 °C temperature set point can be replaced by 23 °C.]

Atmospheric pressure in the test cell shall be between 80 kPa and 110 kPa.

[To ensure the comparability of the certified ICE Power at the reference points, if the test room can not be set to the reference atmospheric conditions as applicable by the engine certification, the following parameters need to be inside a tolerance of $0,93 \leq X \leq 1,07$ for SI engines and $0,9 \leq Y \leq 1,1$ for CI engines:

$X = \alpha_a$ clause 6.3.1 or $Y = \alpha_d$ clause 6.3.2 according to engines certified by ISO 1585:1992

$X = \alpha_a$ clause 5.4.1 or $Y = \alpha_d$ clause 5.4.2 according to engines certified by UN Regulation 85

$X = CA$ clause 5.6 or $Y = CA$ Appendix A according to engines certified by SAE J 1349

For a manufacturer as referenced in 8.9.2.1 which uses a local or regional regulation the applicable clause shall be provided by the manufacturer.]

7.1.3. Cooling fan

A current of air of variable speed shall be blown towards the vehicle sufficient to maintain the proper system operating temperatures (see paragraph 8.8.1.). [and system functions]. The set point of the linear velocity of the air at the blower outlet shall be equal to the corresponding dynamometer speed above measurement speeds of 5 km/h. The deviation of the linear velocity of the air at the blower outlet shall remain within $\pm 10 \%$ of the corresponding measurement speed, up to the maximum speed of the blower. Excessive cooling is prohibited.

7.1.4. Soak area

The soak area shall have a temperature set point of 25 °C. The tolerance of the actual value shall be within ± 5 °C. At the request of the manufacturer, the 25 °C temperature set point can be replaced by 23 °C

7.2. Measurement

7.2.1. Measurement items and accuracy

Measurement devices shall be of certified accuracy as shown in Table 2 traceable to an approved regional or international standard.

Table 2
Measurement items and required accuracy

<i>Item</i>	<i>Units</i>	<i>Accuracy</i>	<i>Remarks</i>
Engine speed	min ⁻¹	± 10 min ⁻¹ or ± 0.5% of measured value, or from onboard engine speed signal	
Intake manifold pressure	Pa	± 2 %	
Atmospheric pressure	Pa	±0.1 kPa, with a measurement frequency of at least 0.1 Hz, or from onboard atmospheric pressure signal	
Specific humidity	g H ₂ O/kg dry air	± 1 g H ₂ O/kg dry air	
Fuel flow rate	g/s	± 3 %, or from onboard fuel flow rate signal	
Electrical voltage	V	±0.3 % FSD or ±1 % of reading	Whichever is greater. Resolution 0.1 V.
Electrical current	A	±0.3 % FSD or ±1 % of reading	Whichever is greater. Current integration frequency 20 Hz or more for external measurement. Resolution 0.1 A.
Room temperature	K	±1 °C, with a measurement frequency of at least 0.1 Hz	
Dynamometer speed	km/h	The dynamometer speeds shall be controlled with an accuracy of ±0.2 km/h or ±0.1% of full scale vehicle speed, whichever is greater.	
Dynamometer force	N	The accuracy of the force transducer shall be at least ±10 N for all measured increments. This shall be verified upon initial installation, after major maintenance and within 370 days before testing.	
Time	s	± 100 ms; min. precision and resolution: 100 ms	
Axle/wheel rotational speed	rev/s	± 0.05 s ⁻¹ or ± 1 %, whichever is greater	
Axle/wheel torque	Nm	± 6 Nm or ± 0.5 % of the maximum measured total torque, whichever is greater, for the whole vehicle.	
Accelerator pedal command	percent	As read from onboard accelerator pedal command signal	

7.2.2. Measurement frequency

All the items in Table 2 of paragraph 7.2.1., unless specified otherwise in the table, shall be measured and recorded at a frequency equal to or greater than 10 Hz.

The items atmospheric pressure and room temperature shall be at least recorded as single measurement activity at start of vehicle operation (see paragraph 8.8.5.) and after end of vehicle running (see paragraph 8.8.8.).

8. Test procedure

8.1. General

The following test procedures determine a vehicle system power rating for a hybrid electric vehicle, or for a pure electric vehicle with more than one propulsion energy converter.

Two test procedures are described herein.

Test procedure 1 (TP1) is based on measured electrical power, estimated ICE power, and estimated electrical conversion efficiency.

Test procedure 2 (TP2) is based on measured torque and speed at the drive shaft(s) or wheel hub(s) and estimated mechanical conversion efficiency.

TP1 and TP2 are intended to be technically equivalent methods for determining a vehicle system power rating from available measurements. TP1 and TP2 are distinguished by the specific instrumentation, measurements, other inputs, and calculations necessary to determine the vehicle system power rating.

Each powered axle that provides propulsion under the maximum power condition shall be tested by chassis dynamometer or hub dynamometer. Vehicles that are powered by two powered axles under the maximum power condition shall be tested by four-wheel-drive chassis dynamometer, or each powered axle shall be tested simultaneously by hub dynamometer. In the case of vehicles whose maximum power, in the judgment of the Type-Approval Authority, exceeds that of readily available dynamometers, it is permissible to use a system bench in place of a dynamometer.

8.1.1. Required information

The manufacturer shall provide the following information required to conduct either test procedure.

8.1.1.1. [Power flow] description

The manufacturer shall provide a power flow description sufficient to identify the energy flow paths and energy conversions by which propulsion is produced during the maximum power condition, beginning at each of the propulsion energy storage systems and proceeding to each powered axle. The description shall also indicate each non-propulsion auxiliary and peripheral device that is powered by the REESS under this condition, including DC/DC converter and high-voltage auxiliaries or peripherals.

The description shall also indicate the power determination reference points applicable to the vehicle (according to the guidelines in Annex 3 of this Regulation), the measurement points according to TP1 or TP2, and the components to which applicable energy conversion factors (K factors) apply.

8.1.1.2. Energy conversion factors (K factors)

Where TP1 is to be performed, the manufacturer shall provide the electrical energy conversion efficiency (K1) between each electrical measurement point and corresponding reference point, applicable to the maximum power condition. In general, K1 factors represent output power of an electric machine

(or a combination of electric machines where applicable) divided by input power to the inverter that powers the electric machine(s).

In determining or verifying a K1 factor, the electrical conversion efficiency of the inverter and electric machine or their combinations shall be determined by an applicable test standard such as ISO 21782, SAE J 2907, or equivalent. The provided value is subject to verification by the Type-Approval Authority.

Where TP2 is to be performed, the manufacturer shall provide, for each powered axle, the mechanical energy conversion efficiency (K2) between each axle or wheel hub power measurement point and corresponding reference point(s), applicable to the maximum power condition. In general, K2 factors represent mechanical power output to the axle shafts or wheel hubs divided by mechanical power input to a gearbox or set of similar mechanical components by which the mechanical power is conducted from the applicable reference point(s).

In determining or verifying a K2 factor, the mechanical conversion efficiency of drivetrain components or their combinations shall [either be determined by dividing the measured output power by the measured input power or at the request of the manufacturer and subject to approval by the Type-Approval Authority other equivalent methods. The provided value is subject to verification by the Type-Approval Authority.]

8.1.1.3. Speed of maximum power

The speed of maximum power (as defined in paragraph 2.5.5.) shall be determined by the procedure specified in Annex 4, either by the manufacturer or by the Type-Approval Authority.

8.1.1.4. Other information

The manufacturer shall specify the normal operating range for each operational metric listed in 8.8.1.

Regarding any dynamometer operation mode (see paragraph 8.7.), the manufacture shall provide a list of the deactivated devices and justification for the deactivation.

8.1.2. Required measurements

The test vehicle shall be instrumented with measurement devices for measuring the necessary input values for the power calculation.

As an alternative to use of measurement devices, use of onboard measurement data for engine speed, intake manifold pressure, and fuel flow rate is permissible. Use of onboard measurement data for other measurements is permissible if the accuracy and frequency of these data is demonstrated to the Type-Approval Authority to meet the minimum requirements for accuracy and frequency described in paragraph 7.2. If TP1 is applied for the system power measurement and onboard measurement data is used for the confirmation of intake manifold pressure and fuel flow rate, the manufacturer has to ensure that values of those onboard measurement data have been recorded during UN Regulation No. 85 or ISO 1585 certification. Measurements common to both TP1 and TP2 include accelerator pedal command, atmospheric pressure, room temperature, and the operational metrics listed in paragraph 8.8.1.

For the purpose of internal validation (see paragraph 8.10.), the power delivered by the vehicle to the dynamometer during the maximum power condition shall be recorded (for example, by recording dynamometer wheel speed and torque, or dynamometer power if available, at a minimum of 10 Hz).

8.1.2.1. Measurements specific to TP1

For TP1, the following measurements are additionally required: electrical current and voltage at the REESS or inverter inputs (as specified according to

paragraph 8.1.3.1.), and ICE speed, intake manifold pressure, and fuel flow rate (if the hybrid power flow description indicates that an ICE contributes propulsion power during the maximum power condition). In this case, TP1 also requires an applicable full load power curve for the ICE, and in some cases may require conducting ISO 1585:1992 or UN Regulation No. 85 (as described in paragraph 8.9.2.1.).

If a DC/DC converter is powered by the REESS for the purpose of providing power to the 12-volt auxiliary bus, the manufacturer may elect to measure current and voltage at the input to the DC/DC converter in lieu of using the default of 1.0 kW.

If the hybrid power flow description indicates that high-voltage auxiliaries other than the above-mentioned DC/DC converter are powered by the REESS during the maximum power condition, the power consumed shall be measured or estimated (see paragraph 8.9.2.2.).

8.1.2.2. Measurements specific to TP2

For TP2, the following measurements are additionally required: torque and rotational speed at the powered axle shafts or wheel hubs.

Important: if the ICE power needs to be corrected according to the provisions of 8.9.3.2., the measurement requirements of TP1 with regard to current and voltage may also apply (see paragraph 6.9.3.3.).

Wheel torque and rotational speed measurement may be provided either by means of a hub dynamometer or by means of appropriate, calibrated measurement device(s) for torque and rotational speed of the powered axle shaft(s) or wheel hub(s).

If a powered axle delivers power to the wheels through a differential, it is sufficient to instrument and collect data from only one of the two drive shafts or wheel hubs. In this case, the measured torque at a drive shaft or wheel hub shall be multiplied by 2 in order to get the total torque per powered axle.

8.1.3. Test procedure applicability

Applicability of TP1 and TP2 varies with powertrain architecture, depending on the ability for one or the other procedure to determine the power at the reference point(s) that are applicable to the powertrain architecture.

The Type-Approval Authority shall confirm that the reference points identified in the hybrid power flow description are in accordance with the requirements of Annex 3 and the definition of "power determination reference point" in paragraph 2.5.3.

The Type-Approval Authority shall use the following considerations to determine applicability of TP1 and TP2 to the test vehicle. Where both TP1 and TP2 are applicable, the choice may be made by the manufacturer.

When reported for type-approval, the vehicle system power rating that is determined by use of this Regulation shall be identified as having been determined by either TP1 or TP2.

8.1.3.1. Applicability of TP1

Applicability of TP1 requires that the power passing through all reference points can be accurately determined by performing the prescribed procedure.

Subject to this requirement, TP1 is typically applicable if either of the following conditions in paragraphs 8.1.3.1.1. or 8.1.3.1.2. are fulfilled:

- 8.1.3.1.1. The hybrid power flow description indicates that the electrical current from each REESS powers a single electric machine, and current and voltage at the output of each REESS can be determined, and the manufacturer provides an

accurate K1 factor representing the electrical conversion efficiency between the input to the inverter and the corresponding reference point.

Figure 16

Example of Case 8.1.3.1.1., TP1 applicable.

$$\text{Power at R [kW]} = (U \text{ [V]} * I \text{ [A]} / 1000) * K1$$

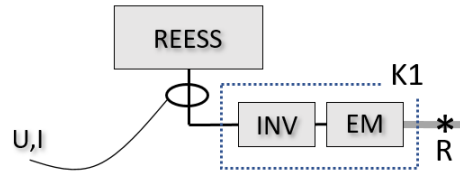

Or,

8.1.3.1.2. At least one of the following conditions (a) to (d) is fulfilled:

- (a) Current and voltage at the input to each inverter that is powered by the REESS can be determined, and the manufacturer provides accurate K1(n) factors representing the electrical conversion efficiency between each input and the corresponding reference point(s).

Figure 17

Example of Case 8.1.3.1.2.(a), TP1 applicable.

$$\text{Power at R1 [kW]} = (U1 \text{ [V]} * I1 \text{ [A]} / 1000) * K1(1)$$

$$\text{Power at R2 [kW]} = (U2 \text{ [V]} * I2 \text{ [A]} / 1000) * K1(2)$$

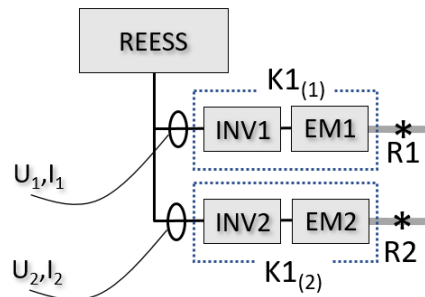

- (b) Current and voltage at the output of the REESS can be determined, and the manufacturer provides an accurate K1comb factor representing the combined electrical conversion efficiency of the inverters and electric machines between the REESS and the corresponding reference point(s).

Figure 18

Example of Case 8.1.3.1.2.(b), TP1 applicable

$$\text{Power at (R1 + R2) [kW]} = (U \text{ [V]} * I \text{ [A]} / 1000) * K1comb$$

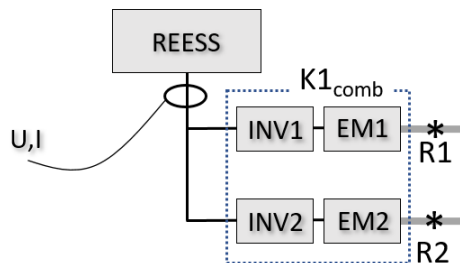

- (c) Current and voltage at the output of the REESS can be determined, and the electrical conversion efficiency between the input to each inverter and the corresponding reference point is identical and is thus represented by the same K1 factor.

Figure 19

Example of Case 8.1.3.1.2.(c), TP1 applicable

$$\text{Power at (R1 + R2) [kW]} = (U \text{ [V]} * I \text{ [A]} / 1000) * K1$$

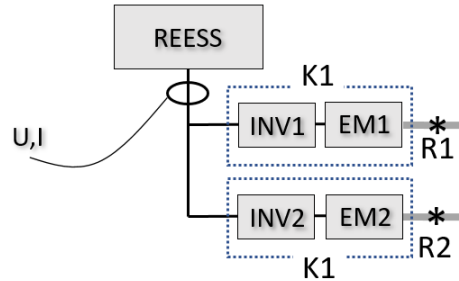

- (d) Current and voltage at the output of the REESS can be determined, and the distribution ratio (DR(1) and DR(2)), which represents the relative distribution of power to R1 and R2, respectively, can be accurately determined by reference to onboard torque command values.

Figure 19a

Example of Case 6.1.3.1.2.(d), TP1 applicable

$$\text{Power at R1 [kW]} = (U \text{ [V]} * I \text{ [A]} / 1000) * K1(1) * DR(1)$$

$$\text{Power at R2 [kW]} = (U \text{ [V]} * I \text{ [A]} / 1000) * K1(2) * DR(2)$$

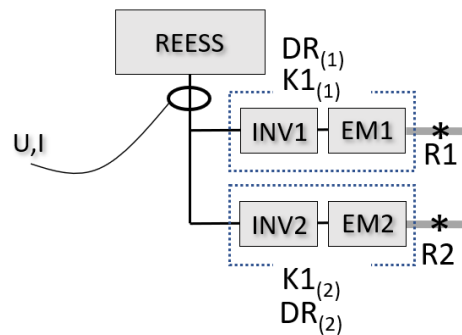

8.1.3.2. Applicability of TP2

Applicability of TP2 requires that the power passing through all reference points can be accurately determined by performing the prescribed procedure. Each powered axle is to be evaluated separately. TP2 is applicable only if it is applicable to all powered axles.

Subject to these requirements, TP2 is typically applicable to a powered axle if either of the following conditions in paragraphs 8.1.3.2.1. or 8.1.3.2.2. are fulfilled:

- 8.1.3.2.1. The hybrid power flow description indicates that torque to the axle originates from a single reference point, and the torque from the reference point is routed only to that axle, and the manufacturer provides an accurate K2 factor representing the mechanical conversion efficiency between the reference point and the measurement point.

Figure 20

Example of Case 8.1.3.2.1., TP2 applicable to axle.

Power at R1 [kW] = $(2\pi * \tau \text{ [Nm]} * \text{rps [s}^{-1}\text{]} / 1000) / K2$

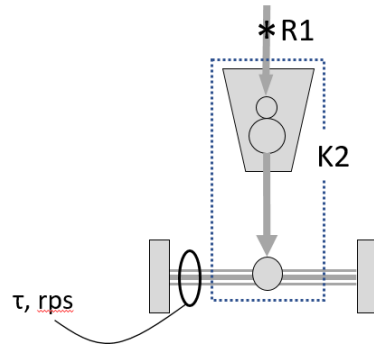

Note: measurement point represents both axle shafts.

Or,

- 8.1.3.2.2. The hybrid power flow description indicates that torque to the axle is a combined torque consisting of torque contributions from a set of reference points, and all of the torque contributions are routed only to that axle via the same mechanical energy path between the set of reference points and the measurement point, and the manufacturer provides an accurate K2 factor representing the mechanical conversion efficiency between the set of reference points and the measurement point.

Figure 21

Example of Case 8.1.3.2.2., TP2 applicable to axle.

Power at (R1 + R2) [kW] = $(2\pi * \tau \text{ [Nm]} * \text{rps [s}^{-1}\text{]} / 1000) / K2$

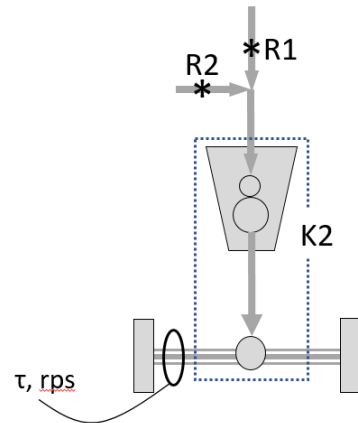

Note: measurement point represents both axle shafts.

[TP2 is not applicable to an axle if power at R1, R2, or (R1 + R2) cannot be resolved from the available measurement.]

Figure 22

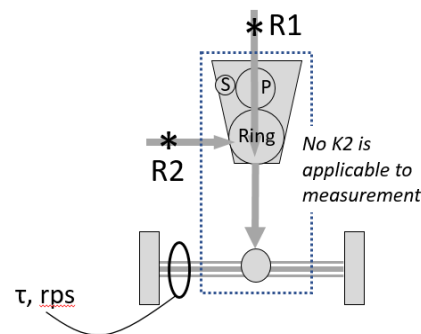
Example of TP2 not applicable to axle.**Power at R1, R2, or (R1 + R2) cannot be resolved from the available measurement**

Note: measurement point represents both axle shafts.

- 8.2. Preparation of dynamometer
 - 8.2.1. Roller (chassis dynamometer only)

Chassis dynamometer roller(s) shall be clean, dry and free from foreign material which can cause tyre slippage.
 - 8.2.2. Tyre slippage (chassis dynamometer only)

Measures shall be taken to stabilize tyre slippage that may occur during maximum power. The use of and amount of any additional weight placed in or on the vehicle, or the use of other measures for this purpose, shall be recorded.
 - 8.2.3. Dynamometer warm-up

The dynamometer shall be warmed up in accordance with the dynamometer manufacturer's recommendations, or as appropriate, so that the frictional losses of the dynamometer may be stabilized.
 - 8.2.4. Dynamometer control

For vehicle conditioning (paragraph 8.8.3.), the dynamometer shall be controlled in road load mode or as allowed according to the provisions therein. For the power test (paragraph 8.8.6), the dynamometer shall be controlled in fixed speed mode.
- 8.3. Preparation of vehicle

The vehicle shall be presented in good technical condition and shall be run-in in accordance with the manufacturer's recommendations.

OVC-HEVs and NOVC-HEVs shall have been run-in and driven between 3,000 and 15,000 km before the test. The engine, transmission and vehicle shall be run-in in accordance with the manufacturer's recommendations.

PEVs shall have been run-in at least 300 km or one full charge distance, whichever is longer.

[In case of measurements on chassis dynamometer], the vehicle shall be fitted with tyres of a type specified as original equipment by the vehicle manufacturer. The tyres shall be inflated to a pressure in accordance with the vehicle manufacturer's recommendations or the owner's manual. If needed to adjust for the effect of added weight to prevent slippage (see paragraph 8.2.2), tyre pressure may be increased by up to 50 per cent above the lower limit of the tyre pressure range for the respective axle for the selected tyre at the coast-down test mass, as specified by the vehicle manufacturer. The same tyre pressure shall be used for the setting of the dynamometer and for all subsequent testing. The tyre pressures used shall be recorded.

The vehicle lubricants and levels specified by the manufacturer shall be used.

Fuel shall be the same fuel that was used for certification of the ICE, if equipped. For example, the fuel specified in UN Regulation No. 85 shall be used for vehicles equipped with an ICE certified under that regulation.

8.4. Preparation of measurement devices

The measurement devices shall be installed at suitable position(s) within the vehicle.

8.5. Initial charge of REESS

For PEVs and OVC-HEVs, prior to or during vehicle soak (paragraph 8.6), the REESS shall be charged to an initial SOC at which maximum system power is obtained. The manufacturer may specify the initial SOC at which maximum system power is obtained.

The initial charge of the REESS shall be conducted at an ambient temperature of. 10 °C – 30 °C

The REESS shall be charged to the initial SOC in accordance with the procedure specified by the manufacturer for normal operation [(means operation described in handbook by manufacturer for SOC usage)] until the charging process is normally terminated.

The SOC shall be confirmed by a method provided by the manufacturer.

8.6. Vehicle soak

The vehicle shall be soaked in the soak area for a minimum of 6 hours and a maximum of 36 hours with the engine compartment cover opened or closed. The manufacturer may recommend a specific soak time or range of soak times within the range of 6 to 36 hours if necessary to ensure temperature stabilization of the high voltage battery. The soak area conditions during soak shall be as specified in paragraph 7.1.4.

8.7. Vehicle installation

The vehicle shall be installed on the dynamometer in accordance with the dynamometer manufacturer's recommendation, or regional or national regulations.

Auxiliary devices shall be switched off or deactivated during dynamometer operation unless their operation is required by regional legislation.

If necessary to operate properly on the dynamometer, the vehicle's dynamometer operation mode shall be activated by using the manufacturer's instruction (e.g. using vehicle steering wheel buttons in a special sequence, using the manufacturer's workshop tester, removing a fuse).

The manufacturer shall provide the Type-Approval Authority a list of the deactivated devices and justification for the deactivation. The dynamometer operation mode shall be approved by the Type-Approval Authority and the use of a dynamometer operation mode shall be recorded.

The vehicle's dynamometer operation mode shall not activate, modulate, delay or deactivate the operation of any part that affects the emissions, fuel or energy consumption, or maximum power under the test conditions. Any device that affects the operation on a dynamometer shall be set to ensure a proper operation.

Measurement devices installed within the vehicle shall be warmed up as appropriate.

8.8. Test sequence

8.8.1. General

The test shall be carried out in accordance with paragraphs 8.8.3. to 8.8.8., and 8.9. to 8.10. (see Figure 23). The test shall be stopped immediately if warning indicator(s) with regard to the powertrain turns on.

Note: Warnings are coolant temperature and engine check lamp, for example.

The following operational metrics, if present, shall be monitored and recorded throughout the test: (a) engine coolant temperature, (b) battery temperature (as indicated by temperature of battery cells, modules, or pack, as available), (c) transmission or gearbox oil temperature, (d) battery SOC, (e) electric machine temperature (as indicated by temperature of stator, rotor, or cooling fluid, as available). The manufacturer shall specify the normal operating range for each operational metric.

8.8.2. Speed of maximum power

If the manufacturer has not provided the speed of maximum power, or the Type-Approval Authority wishes to verify the provided value, determine the speed of maximum power by the procedure described in Annex 4.

8.8.3. Vehicle conditioning

The measurement devices shall start collecting data.

The object of conditioning is to operate the vehicle until the normal operating temperature ranges specified by the manufacturer (paragraph 8.1.1.4.) for the temperature-related operational metrics (paragraph 8.8.1.) have been reached and have stabilised.

Prior to the test, perform initial conditioning by placing the vehicle in the power-rating mode, if applicable (see paragraph 8.8.5.), and run at the speed of 60 km/h at the vehicle road load for at least 20 minutes, or as recommended by the vehicle manufacturer. The vehicle manufacturer or the Type-Approval Authority may specify a different time period, speed, driver-selectable mode, dynamometer mode, or cycle, as necessary to achieve stable operating metrics.

At the end of initial vehicle conditioning, the operational metrics (see paragraph 8.8.1.) shall be recorded.

During the test, monitor the operating metrics and perform additional conditioning as necessary to maintain the operating metrics within the normal operating temperature ranges.

8.8.4. REESS adjustment

During vehicle conditioning according to paragraph 8.8.3., the SOC shall be monitored. The SOC shall be adjusted at the end of vehicle conditioning to the SOC at which maximum system power is obtained as recommended by the manufacturer. REESS adjustment also applies to power test repetitions as directed in paragraph 8.8.7.

REESS adjustment may be performed by use of light regenerative braking, or by allowing the vehicle to coast, while the dynamometer is operated in fixed speed mode, or as recommended by the manufacturer. The charge rate by either method shall be monitored and shall be limited as recommended by the manufacturer to avoid undue heating of the battery or de-rating of the battery power.

8.8.5. Vehicle operation

For vehicles that have driver-selectable modes, the vehicle system power rating that is determined by this procedure may depend on which mode is active during the test. Select the mode for which a vehicle system power rating is desired.

The selected mode shall be recorded as the power-rating mode.

Place the dynamometer in fixed speed mode.

Set the dynamometer fixed speed to the speed of maximum power and allow the speed to stabilize.

8.8.6. Power test

The maximum accelerator pedal command shall be given by either the pedal position or by vehicle communication network for a duration of at least 10 s.

The maximum accelerator command shall be given as rapidly as possible. If necessary in order to elicit maximum power delivery, it is permissible to vary the accelerator pedal command as recommended by the manufacturer prior to the maximum accelerator pedal command (for example, ask the manufacturer if it is necessary to achieve a kickdown state).

If the gearbox has driver-selectable gears, the gear shall be selected as recommended by the manufacturer for a typical driver to achieve maximum power. Gear shifting by means of special modes or actions that are not available to a typical driver are not permitted.

8.8.7. Repetition of power test

The power test of paragraph 8.8.6. shall be repeated for a total of five repetitions as shown in Figure 23.

Prior to the second and subsequent repetitions, the REESS shall be adjusted according to paragraph 8.8.4.

The temperature-related operational metrics listed in paragraph 8.8.1. shall be monitored during all repetitions and seen to remain within the normal operating range specified by the manufacturer during each repetition. Re-condition the vehicle according to paragraph 8.8.3. between repetitions if necessary.

Figure 23
Test sequence

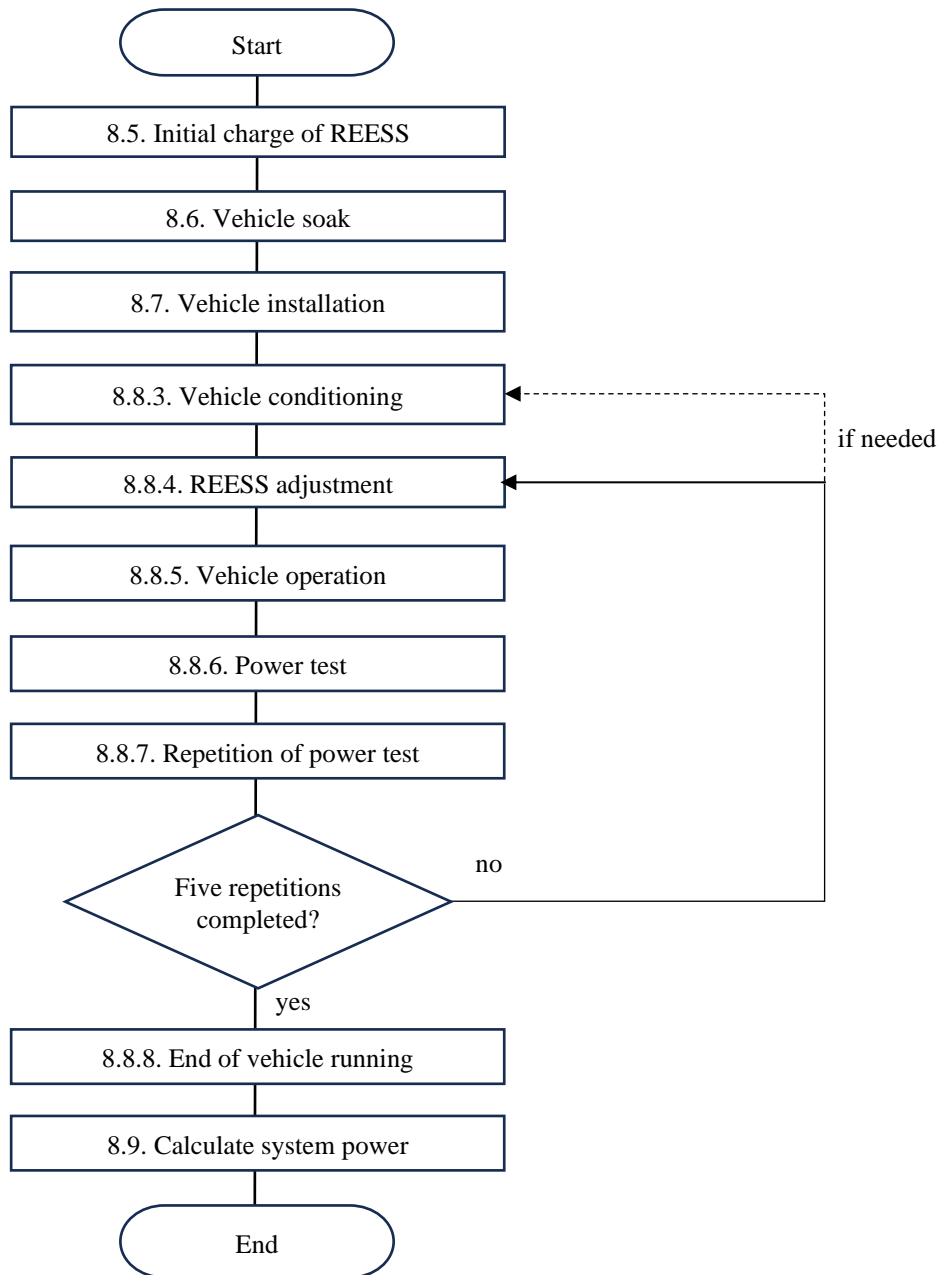

8.8.8. End of vehicle running

At the end of vehicle running, the operational metrics (see paragraph 8.8.1.) shall be recorded.

After the measurements are complete, the vehicle and measurement devices shall be stopped.

8.9. Calculation of vehicle system power rating

8.9.1. General

For each of the 2nd, 3rd, 4th and 5th repetitions according to paragraph 8.8.7., time series data obtained from paragraph 6.8. shall be analysed to calculate vehicle system power.

For each repetition, two power calculations shall be performed:

- (a) Peak vehicle system power: a 2-second "peak" power that is the maximum value of a 2-second moving average filter applied for the 10-second measurement time; and
- (b) Sustained vehicle system power: a "sustained" power that defines the average power within the measurement time window from 8 s to 10 s.

For computation purposes, the 10-second measurement time window begins when the accelerator pedal command has reached maximum as indicated by the accelerator pedal command measurement, and the gear ratio (if changed) has begun a period in which it is constant for at least 10 seconds.

If the vehicle design does not provide for a stable gear ratio to be achieved for a full 10 seconds under the maximum power condition, the time window may begin according to the manufacturer's recommendation, with the approval of the Type-Approval Authority.

Finally, compute the peak and sustained vehicle system power ratings for the vehicle, as the mean of the respective individual results of the four analysed repetitions.

The variation of each of the four analysed repetitions shall be computed as a percentage of their mean, and recorded.

The maximum variation of an individual value should not be greater than $\pm 5\%$ of the mean. If the variation is too large, check the dynamometer settings and vehicle configuration, consult with the manufacturer for possible causes, and perform the repetitions again. If variation cannot be reduced, the system power rating is subject to approval by the Type-Approval Authority.

8.9.2. Calculation for TP1

The vehicle system power is calculated as the sum of the power at each of the reference points:

$$\text{Vehicle system power [kW]} = \sum_{i=1}^n R_i$$

where

n is the number of power determination reference points

R_i is the power at the i^{th} reference point [kW]

The power at each R_i is determined according to paragraphs 8.9.2.1. to 8.9.2.3.:

8.9.2.1. For reference points consisting of ICE power:

First determine the ICE power by reference to the full load power curve as a function of engine speed, applicable to the engine that is installed in the vehicle, and subject to confirmation of intake manifold pressure and fuel flow

rate. The full load power curve shall be derived from the applicable engine test standard and shall be measured under steady state conditions.

For manufacturers to which engine certification by ISO 1585 or UN Regulation 85 is applicable by regulation, the applicable engine test standard is ISO 1585:1992 or UN Regulation No. 85, respectively. For other manufacturers, the applicable standard is that which is applicable by local or regional regulation. In the case that no engine test standard is applicable by regulation, the applicable standard is SAE J 1349 (steady state). The engine dynamometer test fuel shall be as specified in the applicable standard.

To confirm intake manifold pressure and fuel flow rate, compare the measured values to those reported in the certification results of the applicable standard at the measured engine speed.

If:

$$\begin{aligned} & |(\text{measured fuel flow rate} - \text{fuel flow rate at certification})| \\ & < (0.05)(\text{fuel flow rate at certification}) \end{aligned}$$

and

$$\begin{aligned} & |(\text{gauge pressure at test} - \text{gauge pressure at certification})| \\ & < (0.05)(\text{intake manifold pressure at certification}) \end{aligned}$$

then R_i is the power indicated by the full load power curve at the measured engine speed.

Otherwise, determine R_i by conducting ISO 1585:1992 or UN Regulation No. 85 (as applicable) under the observed conditions using the above-measured engine speed, intake manifold pressure and fuel flow rate, or ask the vehicle manufacturer for support in determining the ICE power under the observed conditions.

Note: if any portion of R_i is routed to charge the REESS, the electrical power entering the REESS shall be accounted for as negative power under paragraph 8.9.2.2.

8.9.2.2. For reference points consisting of electric machine power, and where the measurement point is the REESS output:

R_i shall be determined by the equation:

$$R_i \text{ [kW]} = \left(\frac{U_{\text{REESS}} \times I_{\text{REESS}}}{1000} - P_{\text{DCDC}} - P_{\text{aux}} \right) \times K1$$

where

U_{REESS} is the measured REESS voltage [V]

I_{REESS} is the measured REESS current [A] (negative if flowing into the REESS)

P_{DCDC} is the power to DC/DC converter for 12 V auxiliaries, if present (either 1.0 kW or measured value) [kW]

P_{aux} is the power to high-voltage auxiliaries powered by the REESS, other than P_{DCDC} , if present and operating during the test (measured or estimated value) [kW]. If estimated, the manufacturer shall provide evidence supporting the estimated value. Use of the estimated value is subject to approval by the Type-Approval Authority.

$K1$ is the conversion factor from DC electrical power to mechanical power as described in paragraphs 8.1.1.2. and 8.1.3.1.

If $K1$ represents a conversion to the sum of the power at a set of reference points (for example, $(R1 + R2)$ as depicted in Figure 18), the equation computes the sum of the power at the set of reference points.

If P_{DCDC} and P_{aux} are measured, they are calculated as:

$$P_{DCDC} [\text{kW}] = (U_{DCDC} \times I_{DCDC}) / 1000$$

$$P_{aux} [\text{kW}] = (U_{aux} \times I_{aux}) / 1000 \quad (\text{for each applicable auxiliary})$$

where

U_{DCDC} is the voltage to DC/DC converter for 12 V auxiliaries [V]

I_{DCDC} is the current to DC/DC converter for 12 V auxiliaries [A]

U_{aux} is the voltage to the auxiliary [V]

I_{aux} is the current to the auxiliary [A]

8.9.2.3. For reference points consisting of electric machine power, and where the measurement point is the inverter input:

R_i shall be determined by the equation:

$$R_i [\text{kW}] = \left(\frac{U_{Input} \times I_{Input}}{1000} \right) \times K1$$

where

U_{Input} is the measured DC voltage at the inverter input [V]

I_{Input} is the measured current at the inverter input [A]

$K1$ is the conversion factor from DC electrical power to mechanical power as described in paragraphs 8.1.1.2. and 8.1.3.1.

If $K1$ represents a conversion to the sum of the power at a set of reference points (for example, if the inverter powers a set of electric machines), the equation computes the sum of the power at the set of reference points.

8.9.3. Calculation for TP2

8.9.3.1. Calculation

The vehicle system power is calculated as the sum of the power at each of the reference points:

$$\text{Vehicle system power} [\text{kW}] = \sum_{i=1}^n R_i$$

The power at each reference point is calculated as:

$$R_i [\text{kW}] = \left(\frac{P_{axle}}{K2} \right)$$

Where

P_{axle} is the power measured at the respective powered axle [kW]:

$$P_{axle} [\text{kW}] = (2\pi \times \text{axle shaft or wheel speed} [\text{rev} \cdot \text{s}^{-1}] \times \text{axle shaft or wheel torque} [\text{Nm}]) / 1000$$

$K2$ is the mechanical energy conversion efficiency factor $K2$ applicable to the axle as described in paragraphs 8.1.1.2. and 8.1.3.2.

If $K2$ represents a conversion to the sum of the power at a set of reference points (for example, $(R1 + R2)$ as depicted in Figure 21), the equation computes the sum of the power at the set of reference points.

8.9.3.2. ICE power correction

The ICE power portion of the vehicle system power rating shall be corrected according to the provision given in ISO 1585:1992 clause 6, if:

— the reference atmospheric and temperature conditions, given in ISO 1585:1992 clause 6.2.1; or

— the automatic control conditions according to ISO 1585:1992, clause 6.3 cannot be fulfilled.

Note: if the applicable standard according to paragraph 8.9.2.1. is not ISO 1585 (for example, UN Regulation No. 85), ICE power correction shall be performed according to the equivalent portions of the applicable standard (for example, UN Regulation No. 85 clause 5).

If the ICE power portion needs to be corrected, follow paragraph 8.9.3.3., otherwise continue with paragraph 8.10.

8.9.3.2.1. Corrected vehicle system power rating for TP2

ICE power correction requires a distinct value for the ICE power portion (P_{ICE}) of the vehicle system power rating.

For many powertrain architectures, TP2 does not deliver a distinct value for the ICE power portion. For example, Figure 24 shows a powertrain where TP2 would apply a K2 factor to the power measured at the axles, delivering the sum of R1 (P_{ICE}) and R2 ($P_{non-ICE}$) instead of a distinct value for each.

Figure 24

Example of powertrain where TP2 does not deliver a distinct value for ICE power (R1)

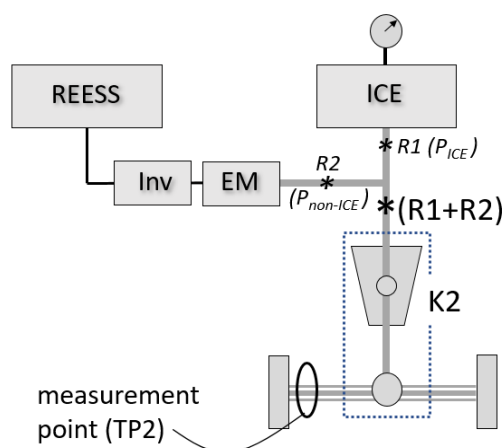

Note: measurement point represents both axle shafts.

If TP2 does not provide a distinct value for P_{ICE} , perform steps (a), (b) and (c) below to derive P_{ICE} by subtracting the power at the non-ICE reference points that were summed with the ICE reference point.

Otherwise, proceed with step (d).

- Identify the set of summed reference points that includes the ICE reference point, and their summed power as delivered by TP2 (P_{summed}).
- Perform TP1 to determine the power at each of the non-ICE reference points in the set, and sum them together to determine the non-ICE portion ($P_{summed, non-ICE}$).
- Subtract the power at the non-ICE reference points ($P_{summed, non-ICE}$) from the summed power (P_{summed}). The result is the measured ICE power, P_{ICE} :

$$P_{ICE}[\text{kW}] = P_{summed}[\text{kW}] - P_{summed, non-ICE}[\text{kW}]$$

- Correct the measured ICE power according to ISO 1585:1992 (or the applicable standard, if different, according to paragraph 8.9.2.1.):

$$P_{ICE, corrected}[\text{kW}] = P_{ICE}[\text{kW}] \times (\text{Power correction factor})$$

where *Power correction factor* is according to ISO 1585:1992, clause 6 (or the equivalent portion of the applicable standard, if different, according to paragraph 8.9.2.1.).

- (e) Compute the corrected vehicle system power rating as the sum of the corrected ICE power and the power at all non-ICE reference points in the powertrain:

$$\text{Vehicle system power}_{\text{corrected}} [\text{kW}] = \left(\sum R_{\text{all non-ICE}} [\text{kW}] \right) + P_{\text{ICE,corrected}} [\text{kW}]$$

Note: Ask the manufacturer if the vehicle control system adjusts the power output of electric machine(s) to electrically compensate for variation in ICE power output due to altitude or air temperature. In this case, the amount of electrical compensation shall be subtracted from the vehicle system power rating after the power correction is performed.

[8.9.4. Interpretation of results

The peak system power or sustained system power for electrified drive trains indicated by the manufacturer for the type of drive train shall be accepted if it does not differ by more than $\pm 5\%$ for peak system power or sustained system power from the values measured by the technical service on the drive train submitted for testing.

The parameters and conditions under which the vehicle's peak system power or sustained system power are reached according to TP1 or TP2 are referenced in Annex I Appendix I link to Information document.]

8.10. Internal validation of vehicle system power rating

The vehicle system power rating according to TP1 or TP2 shall fulfil the following requirement:

The implied downstream efficiency between the reference point(s) and the road shall not be greater than 1. Implied downstream efficiency is computed by dividing the average power recorded at the dynamometer rollers (or hub dyno if applicable) between the 8th and 10th second by the sustained vehicle system power result (prior to any correction under paragraph 8.9.3.3.).

9. General

9.1. Vehicles having the same characteristics with respect to their evaluation for system power may be grouped into vehicle families for the purpose of determining a system power rating considered to be applicable to all vehicles in the family.

9.2. Only vehicles that are the same with respect to all of the following elements may be part of the same family:

- (a) Powertrain system configuration, including number, type, and mechanical arrangement of power sources and operating strategy;
- (b) ICE power rating;
- (c) Net power and construction type (for example, asynchronous, synchronous, or other specific construction type) of all electric machines in the powertrain, and type of electric energy converter(s) between the electric machine(s) and the battery;
- (d) Type of battery cell, including format, capacity, voltage, and chemistry;
- (e) Type of battery pack, including battery configuration (number of cells in series and mode of connection);
- (f) Nominal voltage of the battery;

- (g) Maximum current of the battery; and
- (h) Type of vehicle (PEV, OVC-HEV, or NOVC-HEV).

At the request of the manufacturer, with the approval of the Type-Approval Authority and with appropriate technical justification, the manufacturer may deviate from the above criteria.

[9.3. Identification of families for type-approval

To differentiate between different families within the same vehicle type, e.g. when different K-factors do not affect the parameters in paragraph 9.2., the car manufacturer may specify a unique identifier of the following format:

SP-nnnnnnnnnnnnnnn -WMI

nnnnnnnnnnnnnnnn is a string with a maximum of fifteen characters, restricted to using the characters 0-9, A-Z and the underscore character '_'.

WMI (world manufacturer identifier) is a code that identifies the manufacturer in a unique manner defined in ISO 3780:2009.

It is the responsibility of the owner of the WMI to ensure that the combination of the string nnnnnnnnnnnnnnn and the WMI is unique to the family.]

10. Conformity of production

- 10.1. The conformity of production requirements relating to the power determination of propulsion energy converters are already covered by the rules specified in paragraph 6 of UN Regulation No. 85 and therefore compliance with the conformity of production requirements of UN Regulation No. 85 for all propulsion energy converters in the powertrain can be considered as sufficient to cover the conformity of production requirements for vehicles type approved under this Regulation.
- 10.2. In the absence of approvals to UN Regulation No. 85, the manufacturer shall demonstrate to the Type-Approval Authority that all propulsion energy converters in the powertrain covered by the approval are compliant with the conformity of production requirements of UN Regulation No. 85.

11. Penalties for non-conformity of production

- 11.1. The approval granted in respect of a vehicle type pursuant to this Regulation, may be withdrawn if the requirements of this Regulation are not complied with.
- 11.2. If a Contracting Party to the 1958 Agreement which applies this Regulation withdraws an approval it has previously granted, it shall forthwith so notify the other Contracting Parties applying this Regulation, by means of a communication form conforming to the model in Annex 2 to this Regulation.

12. Production definitively discontinued

- 12.1. If the holder of the approval completely ceases to manufacture a type of vehicle approved in accordance with this Regulation, they shall so inform the Type-Approval Authority which granted the approval. Upon receiving the relevant communication, that Authority shall inform thereof the other Contracting Parties to the 1958 Agreement applying this Regulation by means of copies of the communication form conforming to the model in Annex 2 to this Regulation.

Annex 1

Communication

(Maximum format: A4 (210 x 297 mm))



issued by : (Name of administration)

.....

- concerning²:
- Approval granted
 - Approval extended
 - Approval refused
 - Approval withdrawn
 - Production definitively discontinued

of determination of system power of hybrid electric vehicles and of pure electric vehicles having more than one electric machine for propulsion pursuant to Regulation No. XX.

Approval No.:

Extension No.:

Section I

1. Make (trade name of manufacturer):
2. Type:
3. Commercial name(s) (if available):
4. Version(s):
5. Category of vehicle ⁴:
6. Means of identification of type if marked on the vehicle ³:
 - a. Location of that marking:
7. Name and address of manufacturer :
8. Name(s) and address(es) of assembly plant(s):
9. If applicable, name and address of manufacturer's representative:
10. Internal combustion engine
 - a. Make:
 - b. Type:
 - c. Manufacturer's name and address:
11. Electric drive train(s)
 - a. Make:
 - b. Type:
 - c. Manufacturer's name and address:

¹ Distinguishing number of the country which has granted/extended/refused/withdrawn approval (see approval provisions in the Regulation).

² Strike out what does not apply

³ If the means of identification of type contains characters not relevant to describe the vehicle, component or separate technical unit types covered by this information document, such characters shall be represented in the documentation by the symbol '?' (e.g. ABC??123??)

⁴ As defined in the Consolidated Resolution on the Construction of Vehicles (R.E.3.), document ECE/TRANS/WP.29/78/Rev.3, para. 2

www.unece.org/trans/main/wp29/wp29wgs/wp29gen/wp29resolutions.html

12. Essential characteristics of the engine type:
 - a. Working principle: four stroke / two stroke/rotatory ²⁾
 - b. Number and layout of cylinders:
 - c. Engine capacity:
 - d. Fuel feed: indirect injection / direct injection ²⁾
 - e. Pressure charger device: Yes/No ²⁾
 - f. Exhaust gas cleaning device: Yes/No ²⁾
 - g. Dual-fuel engine: Yes with a diesel mode/Yes without a diesel mode / No ²⁾
 - h. Engine fuel requirements: leaded petrol / unleaded petrol / diesel fuel / CNG / LNG / LPG / Biomethane / Ethanol(E85) / Biodiesel / Hydrogen ²⁾

13. Essential characteristics of the electric drive train(s)
 - a. Working principle:

Section II

1. Technical service responsible for carrying out the tests:
2. Date of test report:
3. Number of test report issued by that service:
4. Reasons for extensions:
5. Remarks (if any):

6. Indicated figures(s) (where applicable, manufacturer's declared values)
 - a. Vehicle's peak system power:
 - b. Vehicle's sustained system power:
 - c. Power rating mode

7. Approval granted/extended/refused/withdrawn²⁾

8. Place:
9. Date:
10. Signature:

Attachments:

Information package

Test reports

Annex 1 Appendix 1

Vehicle characteristics and information concerning the conduct of tests

If there are drawings, they shall be to an appropriate scale and show sufficient detail; they shall be presented in A4 format or folded to that format. Photographs, if any, shall show sufficient detail.

0	GENERAL
0.1.	Make (trade name of manufacturer): ...
0.2.	Type: ...
0.2.1.	Commercial name(s) (if available): ...
0.2.2.	Family Identifier: ...
0.3.	Version(s): ...
0.4.	Category of vehicle: ...
0.5.	Means of identification of type if marked on the vehicle ³⁾ : ...
0.5.1.	Location of that marking: ...
0.6.	Name and address of the manufacturer: ...
0.7.	Name(s) and address(es) of assembly plant(s): ...
0.8.	If applicable, name and address of manufacturer's representative: ...
1	GENERAL CONSTRUCTION CHARACTERISTICS OF THE WHOLE VEHICLE
1.1.	Photographs and/or drawings of a representative vehicle/component/separate technical unit ²⁾ :
1.2.	Technically permissible maximum laden mass stated by the manufacturer: ... kg
1.3.	Powered axles (number, position, interconnection): ...
1.4.	Category of vehicle: ICE/NOVC-HEV/OVC-HEV/PEV ²⁾ : ...
1.5.	Position and arrangement of the engine and/or motor(s): ...
3.	INTERNAL COMBUSTION ENGINE
3.1.	Make: ...
3.2.	Type: ...
3.3.	Manufacturer's name and address: ...
3.4.	Manufacturer's code (as marked on the propulsion energy converter or other means of identification): ...
3.5.	Name(s) and address(es) of assembly plant(s): ...
3.6.	Working principle: positive ignition/compression ignition/dual fuel ²⁾ Cycle: four stroke/two stroke/rotary ²⁾
3.7.	Number and layouts of cylinders: ...
3.7.1	Bore: ... mm
3.7.2.	Stroke: ... mm
3.7.3.	Firing order: ...
3.7.4.	Engine capacity (m): ... cm ³
3.7.5.	Fuel feed: indirect injection / direct injection ²⁾
3.7.6.	Pressure charger device: Yes/No ²⁾
3.7.7	Exhaust gas cleaning device: Yes/No ²⁾
3.7.8.	Dual-fuel engine: Yes with a diesel mode/Yes without a diesel mode / No ²⁾
3.7.9.	Engine fuel requirements: leaded petrol / unleaded petrol / diesel fuel / CNG /LNG / LPG / Biomethane / Ethanol(E85) / Biodiesel / Hydrogen ²⁾

3.7.10.	Volumetric compression ratio: ...
3.7.11.	Drawings of combustion chamber, piston crown and, in the case of positive ignition engines, piston rings: ...
3.8.	Manufacturer's declarations
3.8.1	Maximum rated power: ... kW at ... min ⁻¹ (manufacturer's declared value, if apply as in UN Regulation No. 85 ANNEX 1 §2.11)
3.8.2	Maximum permitted engine speed as prescribed by the manufacturer: ... min ⁻¹
3.8.3	Maximum rated torque: ... Nm at ... min ⁻¹ (manufacturer's declared value, if apply as in UN Regulation No. 85 ANNEX 1 §2.13)
3.8.4	The correction factor for compensating ambient conditions is set to 1, in accordance with §5.4.3. of Annex 5 to UN Regulation No. 85: Yes/No ²⁾

Fill out paragraphs 3.9. to 3.18. only in the case that an internal combustion engine described in paragraph 3.1. and 3.2. is not approved according to UN Regulation No. 85

3.9.	Fuel
3.9.1	Diesel / Petrol / LPG /NG or Biomethane / Ethanol (E85) / Biodiesel / Hydrogen ²⁾
3.9.2	RON, unleaded: ...
3.9.3	Vehicle fuel type: Mono fuel, Bi fuel, Flex fuel ²⁾
3.9.4	Maximum amount of biofuel acceptable in fuel (manufacturer's declared value): ... % by volume
3.10.	Fuel feed
3.10.2.	By fuel injection (compression ignition or dual fuel only): Yes/No ²⁾
3.10.2.1.	System description (common rail/unit injectors/distribution pump etc.): ...
3.10.2.2.	Working principle: direct injection/pre-chamber/swirl chamber ²⁾
3.10.2.3.	Injection/Delivery pump
3.10.2.3.1.	Make(s): ...
3.10.2.3.2.	Type(s): ...
3.10.2.4.	Injector(s)
3.10.2.4.1.	Make(s): ...
3.10.2.4.2.	Type(s): ...
3.10.2.5.	Electronic controlled injection: Yes/No ²⁾
3.10.2.5.1.	Make(s): ...
3.10.2.5.2.	Type(s):
3.10.2.5.3	Description of the system: ...
3.10.2.5.4.	Make and type of the control unit (ECU): ...
3.10.2.5.5.	Software version or RxSWIN of the ECU: ...
3.10.3.	By fuel injection (positive ignition only): Yes/No ²⁾
3.10.3.1.	Working principle: intake manifold (single-/multi-point/direct injection ²⁾ /other (specify): ...
3.10.3.2.	Make(s): ...
3.10.3.3.	Type(s): ...
3.10.3.4.	System description (In the case of systems other than continuous injection give equivalent details): ...
3.10.3.4.1.	Make and type of the control unit (ECU): ...
3.10.3.4.1.1.	Software version or RxSWIN of the ECU: ...
3.10.4.	LPG fuelling system: Yes/No ²⁾
3.10.4.1.	Approval number (approval number of UN Regulation No. 67): ...
3.10.4.2.	Electronic engine management control unit for LPG fuelling
3.10.4.2.1.	Make(s): ...

3.10.4.2.2.	Type(s): ...
3.10.4.3.	Emission-related adjustment possibilities: ...
3.10.4.4.	Further documentation
3.10.4.5.	Description of the safeguarding of the catalyst at switch-over from petrol to LPG or back: ...
3.10.4.6.	System lay-out (electrical connections, vacuum connections compensation hoses, etc.): ...
3.10.4.7.	Drawing of the symbol: ...
3.10.5.	NG fuelling system: Yes/No ²⁾
3.10.5.1.	Approval number (approval number of UN Regulation No. 110):
3.10.5.2.	Electronic engine management control unit for NG fuelling
3.10.5.2.1.	Make(s): ...
3.10.5.2.2.	Type(s): ...
3.10.5.2.3.	Emission-related adjustment possibilities: ...
3.10.5.3.	Further documentation
3.10.5.3.1.	Description of the safeguarding of the catalyst at switch-over from petrol to NG or back: ...
3.10.5.3.2.	System lay-out (electrical connections, vacuum connections compensation hoses, etc.): ...
3.10.5.3.3.	Drawing of the symbol: ...
3.10.6.	Hydrogen fuelling system: Yes/No ²⁾
3.10.6.1.	EC type-approval number in accordance with Regulation (EC) No 79/2009 or Regulation (EU) 2019/2144: ...
3.10.6.2.	Electronic engine management control unit for hydrogen fuelling
3.10.6.2.1.	Make(s): ...
3.10.6.2.2.	Type(s): ...
3.10.6.3.	Emission-related adjustment possibilities: ...
3.10.6.4.	Further documentation
3.10.6.4.1.	Description of the safeguarding of the catalyst at switch- over from petrol to hydrogen or back: ...
3.10.6.4.2.	System lay-out (electrical connections, vacuum connections compensation hoses, etc.): ...
3.10.6.4.3.	Drawing of the symbol: ...
3.11.	Cooling system: liquid/air ²⁾
3.11.1.	Nominal setting of the engine temperature control mechanism: ...
3.11.2.	Liquid
3.11.2.1.	Nature of liquid: ...
3.11.2.2.	Circulating pump(s): Yes/No ²⁾
3.11.2.2.1.	Characteristics: ... or
3.11.2.2.2.	Make(s): ...
3.11.2.2.3.	Type(s): ...
3.11.2.3.	Drive ratio(s): ...
3.11.2.4.	Description of the fan and its drive mechanism: ...
3.11.3.	Air
3.11.3.1.	Fan: Yes/No ²⁾
3.11.3.1.1.	Characteristics: ... or
3.11.3.1.2.	Make(s): ...
3.11.3.1.3.	Type(s): ...
3.11.3.1.4.	Drive ratio(s): ...
3.12.	Intake system
3.12.1.	Pressure charger: Yes/No ²⁾
3.12.1.1.	Make(s): ...
3.12.1.2.	Type(s): ...

3.12.2.	Intercooler: Yes/No ²⁾
3.12.2.1.	Type: air-air/air-water ²⁾
3.12.3.	Description and drawings of inlet pipes and their accessories (plenum chamber, heating device, additional air intakes, etc.): ...
3.12.3.1.	Intake manifold description (include drawings and/or photos): ...
3.12.3.2.	Air filter, drawings: ... or
3.12.3.2.1.	Make(s): ...
3.12.3.2.2.	Type(s): ...
3.12.3.3.	Intake silencer, drawings: ... or
3.12.3.3.1.	Make(s): ...
3.12.3.3.2.	Type(s): ...
3.13.	Exhaust system
3.13.1.	Description and/or drawing of the exhaust manifold: ...
3.13.2.	Description and/or drawing of the exhaust system: ...
3.13.3.	Minimum cross-sectional areas of inlet and outlet ports: ...
3.13.4.	Valve timing or equivalent data
3.13.4.1.	Maximum lift of valves, angles of opening and closing, or timing details of alternative distribution systems, in relation to dead centres. For variable timing system, minimum and maximum timing: ...
3.13.4.2.	Reference and/or setting ranges ²⁾ : ...
3.13.5.	Measures taken against air pollution
3.13.5.1.	Anti-pollution devices
3.13.5.1.1.	Catalytic converter: Yes/No ²⁾
3.13.5.1.2.	Number of catalytic converters and elements:
3.13.5.1.3.	Dimensions, shape and volume of the catalytic converter(s):
3.13.5.1.4.	Oxygen sensor: Yes/No ²⁾
3.13.5.1.5.	Air injection: Yes/No ²⁾
3.13.5.1.6.	Exhaust gas recirculation: Yes/No ²⁾
3.13.5.1.7.	Particulate trap: Yes/No ²⁾
3.13.5.1.8.	Dimensions, shape and capacity of the particulate trap:
3.13.6.	Other systems (description and operation):
3.14.	Lubrication system
3.14.1.	Description of the system
3.14.2.	Position of the lubricant reservoir
3.14.3.	Feed system (by pump / injection into intake / mixing with fuel, etc.) ²⁾
3.14.4.	Lubricating pump
3.14.4.1.	Make(s): ...
3.14.4.2.	Type(s): ...
3.14.5.	Mixture with fuel
3.14.5.1.	Percentage: ...
3.14.6.	Oil cooler: Yes/No ²⁾
3.14.6.1.	Drawing(s): ...
3.14.6.2.	Make(s): ...
3.14.6.3.	Type(s): ...
3.15.	Electrical system
3.15.1.	Rated voltage: ... V, positive/negative ground ²⁾
3.15.2.	Generator
3.15.2.1.	Type: ...
3.15.2.2.	Nominal output: ... VA
3.16.	Ignition system (spark ignition engines only)
3.16.1.	Make(s): ...
3.16.2.	Type(s): ...

3.16.3.	Working principle: ...
3.16.4.	Spark plugs
3.16.4.1.	Make: ...
3.16.4.2.	Type: ...
3.16.4.3.	Gap setting: ... mm
3.16.5.	Ignition coil(s)
3.16.5.1.	Make: ...
3.16.5.2.	Type: ...
3.17.	General
3.17.1.	Make and type or working principle of fuel regulator: ...
3.17.2.	Make and type or working principle of fuel distributor: ...
3.17.3.	Make and type or working principle of air-flow sensor: ...
3.17.4.	Make and type of throttle housing: ...
3.17.5.	Make and type or working principle of water temperature sensor: ...
3.17.6.	Make and type or working principle of air temperature sensor: ...
3.17.7.	Make and type or working principle of air pressure sensor: ...
3.18.	Temperatures permitted by the manufacturer
3.18.1.	Cooling system
3.18.1.1.	Liquid cooling
3.18.1.1.1.	Maximum temperatures at outlet: ... K
3.18.1.2.	Air cooling
3.18.1.2.1.	Reference point: ...
3.18.1.2.2.	Maximum temperature at reference point: ... K
3.18.1.2.3.	Maximum outlet temperature of the inlet intercooler: ... K
3.18.1.2.4.	Maximum exhaust temperature at the point in the exhaust pipe(s) adjacent to the outer flange(s) of the exhaust manifold: ... K
3.18.3.	Fuel temperature
3.18.3.1.	Minimum: ... K
3.18.3.2.	Maximum: ... K
3.18.4.	Lubricant temperature
3.18.4.1.	Minimum: ... K
3.18.4.2.	Maximum: ... K
4.	ELECTRIC MOTOR (describe each type of electric motor separately)
4.1.	Make: ...
4.2.	Type: ...
4.3.	Manufacturer's name and address
4.4.	Manufacturer's code (as marked on the propulsion energy converter or other means of identification)
4.5.	Name(s) and address(es) of assembly plant(s)
4.6.	Drive: Mono-motor / multi-motors ²⁾ / (number)
4.7.	Transmission arrangement: parallel / transaxial / others, to precise ²⁾
4.8.	Basic motor rotation: ... min ⁻¹
4.9.	Manufacturer's declarations
4.9.1.	Motor shaft maximum speed: ... min ⁻¹ (or by default): reducer/gearbox outlet shaft ²⁾
4.9.2.	Maximum rated power: ... kW (manufacturer's declared value, if apply as in UN Regulation No. 85 ANNEX 2 §1.9)
4.9.3.	Maximum rated power speed: ... min ⁻¹ (manufacturer's declared value, if apply as in UN Regulation No. 85 ANNEX 2 §1.8)
4.9.4.	Maximum rated Torque speed (specified by the manufacturer) ... min ⁻¹
4.9.5.	Maximum rated Torque (specified by the manufacturer) ...Nm

4.10.	Motor
4.10.1.	Working principle
4.10.2.	Direct current (DC)/alternative current (AC) ²⁾ number of phases
4.10.3.	Separate excitation/series/compound ²⁾
4.10.4.	Synchron / asynchron ²⁾
4.10.5.	Rotor coiled / with permanent magnets / with housing ²⁾
4.10.6.	Number of poles of the motor: ...

Fill out paragraph 4.11. to 4.18. only in the case that an electric machine described in paragraph 4. is not approved according to UN Regulation No. 85

4.11.	Power controller
4.11.1.	Make: ...
4.11.2.	Type: ...
4.11.3.	Software Version or RxSWIN: ...
4.12.	Electric Energy Converter between Motor and Traction REESS
4.12.1.	Make: ...
4.12.2.	Type: ...
4.12.3.	Software version or RxSWIN
4.12.4.	Control principle: vectorial / open loop / closed / other, to be specified ²⁾
4.12.5.	Maximum effective current supplied to the motor: ... A during ... seconds
4.12.6.	Voltage range from: ... V to ... V
4.13.	Cooling System
4.13.1.	Motor: liquid / air ²⁾
4.13.2.	Controller: liquid / air ²⁾
4.13.3.	Liquid-cooling equipment characteristics
4.13.3.1.	Nature of the liquid ... circulating pumps: Yes/No ²⁾
4.13.3.2.	Characteristics or make(s) and type(s) of the pump
4.13.3.3.	Thermostat: setting
4.13.3.4.	Radiator: drawing(s) or make(s) and type(s)
4.13.3.5.	Relief valve: pressure setting:
4.13.3.6.	Fan: characteristics or make(s) and type(s)
4.13.3.7.	Fan duct
4.14.	Air-cooling equipment characteristics
4.14.1.	Blower: characteristics or make(s) and type(s)
4.14.2.	Standard air ducting
4.14.3.	Temperature regulating system: Yes/No ²⁾
4.14.4.	Brief description
4.14.5.	Air filter make(s) and type(s)
4.15.	Temperatures admitted by the manufacturer
4.15.1.	Motor outlet: (max.) ... K
4.15.2.	Controller inlet: (max.) ... K
4.15.3.	At motor reference point(s): (max.) ... K
4.15.4.	At controller reference point(s): (max.) ... K
4.16.	Insulating category:
4.17.	International protection (IP)-code:
4.18.	Lubrication system ²⁾ Bearings: friction / ball Lubricant: grease / oil Seal: Yes/No Circulation: with / without

5.	DESCRIPTION OF THE ENERGY STORAGE DEVICE (REES, capacitor, flywheel/generator)
5.1.	Make: ...
5.2.	Type: ...
5.3.	Identification number: ...
5.4.	Manufacturer's name: ...
5.5.	Kind of electrochemical couple: ...
5.6.	Nominal voltage: ... V
5.7.	Maximum current: ... A
5.8.	REESS energy: kWh
5.9.	Energy: ... (for REESS: voltage and capacity Ah in 2 h, for capacitor: J, ...)
5.10.	Battery Management System Control Unit: ...
5.10.1.	Make: ...
5.10.2.	Type: ...
5.10.3.	Identification Number or Software Version or RxSWIN: ...
6.	TRANSMISSION (p)
6.2.	Gearbox
6.2.1.	Make: ...
6.2.2.	Type: ...
6.2.3.	Software version or RxSWIN: ...
6.2.4.	Type (manual/automatic/CVT (continuously variable transmission)) 1)
7.	MISCELLANEOUS
7.1.	Power flow description including description of reference points for power determination and components for which energy conversion factors (K) apply (summarize):
7.2.	Test procedure TP1/TP2 ²⁾
7.2.1.	In case of TP1: Energy Conversion Factors (K1) between ... and ...
7.2.2.	In case of TP1, electrical conversion energy of the inverter and electric machine or their combination
7.2.3.	In case of TP2: Energy Conversion Factors (K2) between ... and ...
7.3.	Driver-selectable mode switch: Yes/No ²⁾
7.3.1.	Power rating mode (name and description)
7.4.	Battery temperature nominal range ... K and point of measurement
7.5.	Engine coolant temperature nominal range: ... K
7.6.	Transmission or gearbox oil temperature nominal range ... K
7.7.	Electric machine temperature nominal range: ... K and measurement position
7.8.	System Power (manufacturer's declared value)
7.8.1.	Peak Vehicle System Power: kW
7.8.2.	Sustained Vehicle System Power: kW

Annex 1 Appendix 2

Test Report

	GENERAL
0.1.	Make (trade name of manufacturer) ...
0.2.	Type ...
0.2.1.	Commercial name(s) (if available) ...
0.3.	Category of vehicle ...
0.4.	Version(s) ...
0.5.	Name and address of the manufacturer ...
0.6.	Technical service responsible for carrying out the tests ...
0.7.	Date of test report ...
0.8.	Number of test report issued by that service ...
0.9.	Reason for extension ...
0.10.	Date of issue ...
0.11.	Last amendment from ...
	TEST REPORT
1.	Test Room
1.1.	Atmospheric pressure ... kPa
1.2.	Room temperature ... K
1.3.	Specific humidity ... g H ₂ O/kg dry air
2.	Dynamometer
2.1.	Chassis dynamometer/Hub dynamometer ²⁾
2.2.	Dynamometer operation Mode Yes/No ²⁾
2.3.	If dynamometer operation mode Yes – List of deactivated devices
3.	Test conditions
3.1	Test mass of the vehicle .. Kg
3.2.	dynamic rolling radii... m
3.3.	Power rating mode (name and description)
3.4.	Selected gear for maximum power (if driver selectable gear available)
3.5.	Speed of maximum power ... km/h
3.6.	Accelerator pedal command ... %
3.7.	In case of chassis dynamometer: additional weight to stabilize tyre slippage Yes/No ²⁾
3.7.1.	Additional weight .. Kg
3.7.2.	Tyres pressure adjustment needed Yes/No ²⁾
3.7.2.1.	Tyres and wheels of the test vehicles
3.7.2.2.	Tyres pressure(s) as recommended by the vehicle manufacturer: ... kPa
3.7.2.3.	Tyres pressure adjustment ... kPa
4.	Test procedure
4.1.	Test procedure TP1/TP2 ²⁾
4.2.	Type of test fuel of the ICE (if ICE available)
4.3.	Battery temperature after preconditioning ... K and point of measurement
4.4.	Engine coolant temperature after preconditioning ... K
4.5.	Transmission or gearbox oil temperature after preconditioning... K
4.6.	Battery SOC after preconditioning ... %

4.7.	Electric machine temperature after preconditioning ... K and measurement position
4.8.	Battery temperature Test 1 to 5 start ... K to end ...K and point of measurement
4.9.	Engine coolant temperature test 1 to 5 start ... K to end ...K
4.10.	Transmission or gearbox oil temperature test 1 to 5 start ... K to end ...K
4.11.	Battery SOC test 1 to 5 start ... % to end %
4.12.	Electric motor temperature test 1 to 5 start ... K to end ...K and measurement position
5.	Test results
5.1.	Peak vehicle system power test 2 to 5 ...kW
5.2.	Sustained vehicle system power test 2 to 5 ...kW
5.2.1.	Diagram of measured power over time test 2 to 5 ... K
5.3.	Vehicle's peak system power ...kW
5.4.	Vehicle's Sustained system power ...kW
6	Declared Values stated by manufacturer:
6.1.	Vehicle's peak system power ...kW
6.2.	Vehicle's Sustained system power ...kW
7.	Final values
7.1.	Vehicle's peak system power ...kW
7.2.	Vehicle's Sustained system power ...kW
8.	Internal validation
8.1.	Power delivered by the vehicle to the dynamometer during max power condition ... kW
8.2.	Downstream efficiency ...
9.	For TP1
9.1.	ICE Power....KW
9.1.1.	ICE correction factor according to UN Regulation No. 85 or ISO 1585:1992 or SAEJ1349 or local regulation if applicable
9.2.	Electrical current at REESS or inverter inputs test 2 to 5
9.2.1.	at 2-second peak power as maximum value of 2-second moving average filter ... A
9.2.2.	at sustained power from measurement time windows 8 s to 10 s ...A
9.3.	Electrical voltage at REESS or inverter inputs test 2 to 5
9.3.1.	at 2-second peak power as maximum value of 2-second moving average filter ... V
9.3.2.	at sustained power from measurement time windows 8 s to 10 s ...V
9.4.	ICE Speed test 2 to 5
9.4.1.	at 2-second peak power as maximum value of 2-second moving average filter ... n/min
9.4.2.	at sustained power from measurement time windows 8 s to 10 s ...n/min
9.5.	Intake manifold pressure
9.5.1.	at 2-second peak power as maximum value of 2-second moving average filter ... kPa
9.5.2.	at sustained power from measurement time windows 8 s to 10 s ...kPa
9.6.	Fuel flow rate (in case ICE contributes to propulsion power during the maximum power condition)
9.6.1.	at 2-second peak power as maximum value of 2-second moving average filter ... g/s
9.6.2.	at sustained power from measurement time windows 8 s to 10 s ...g/s
9.7.	Full load power curve for the ICE

9.8.	Current and voltage at the input to DC/DC converter test 2 to 5 or default 1 kW ... kW
9.9.	Power consumed in case high-voltage auxiliaries (other than DC/DC converter) are powered by the REESS during the maximum power condition test 2 to 5 ... KW
9.10.	K1-Factor ...
10.	For TP2
10.1.	Torque at the powered axle or wheel hubs ... Nm
10.2.	Rotational speed at the powered axle or wheel hubs ... n/min
10.3.	K2-Factor
10.4.	ICE correction factor according to UN Regulation No. 85 or ISO 1585:1992 or SAE J1349 or local regulation if applicable
11.	Remarks
12.	Date of Test

Annex 2

Arrangement of the approval mark

In the approval mark issued and affixed to a vehicle in conformity with paragraph 5. of this Regulation, the type-approval number shall be accompanied by an alphanumeric character reflecting the level that the approval is limited to.

This annex outlines the appearance of this mark and gives an example how it shall be composed.

The following schematic graphic presents the general lay-out, proportions and contents of the marking. The meaning of numbers and alphabetical character are identified, and sources to determine the corresponding alternatives for each approval case are also referred.

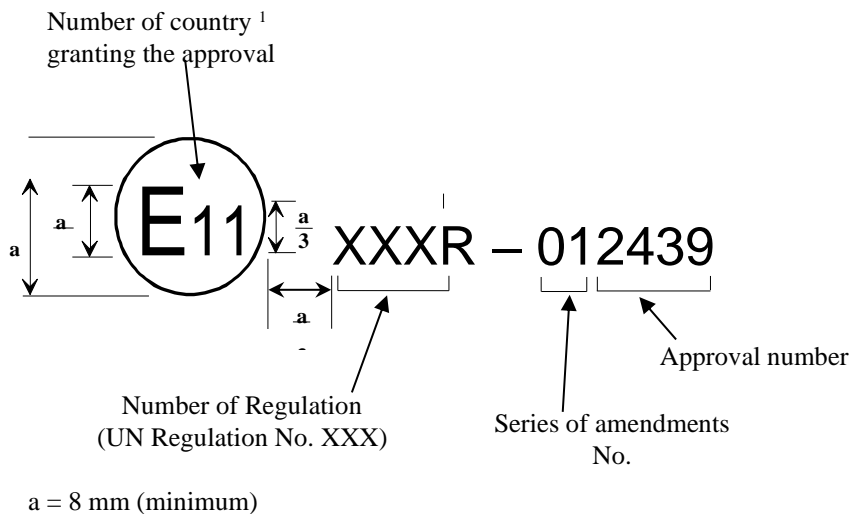

The following graphic is a practical example of how the marking should be composed.



¹ Number of country according to footnote in paragraph 6.1.1. of this Regulation.

Annex 3

Identification of power determination reference points

1. General approach
 - 1.1. Both TP1 and TP2 convert a set of specified vehicle test measurements to a vehicle system power rating that represents the mechanical power transmitted through one or more power determination reference points.
 - 1.2. Power determination reference points are intended to represent points in the mechanical power flow path of an electrified powertrain that are most analogous to the engine output shaft in a conventional vehicle. Here, "analogous" means being a point in the powertrain where mechanical power that drives the wheels is first produced from stored energy. This is consistent with the tradition that conventional vehicles are assigned a system power rating equal to the rated power of the engine, without consideration of the power losses that occur downstream of the engine output shaft.
 - 1.3. A power determination reference point is a point in the mechanical power flow path of an electrified powertrain as defined in paragraph 2.5.3. of this Regulation. In the most general sense, reference points represent where the mechanical power that drives the wheels during the maximum power condition is first produced from an energy storage system. A given electrified powertrain may include one or more power determination reference points as necessary to account for all sources of propulsion power to the powered axle(s). The vehicle system power rating is the sum of the power transmitted through all of the reference points.
 - 1.4. Reference points for complex electrified powertrains can vary depending on the specific power flow paths that are active in a given operating mode of the vehicle or at a given power demand. For the purpose of system power determination under this Regulation, reference points shall be identified according to the requirements of this Annex.
 - 1.5. Calculation of the vehicle system power rating under both TP1 and TP2 shall result in an estimate of the sum of the power at all of the identified reference points during the maximum power condition. The same reference points shall apply to a given powertrain regardless of whether TP1 or TP2 is applied.
2. Identifying power determination reference points
 - 2.1. General considerations
 - 2.1.1. Power determination reference points represent all of the sources of the total mechanical power that is transmitted to the road during the maximum power condition. This means that they are based not only on powertrain architectural layout but also on the state of the powertrain during the maximum power condition and on any applicable operating mode. Propulsion energy converters that are not operating or are not contributing propulsion energy to the road in this state are not included.
 - 2.2. Parallel architectures
 - 2.2.1. The power determination reference points for parallel architectures (example in Figure 25) are generally (a) the engine mechanical power output shaft and (b) the mechanical power output shaft(s) of any electric machines that provide mechanical power to the road. The vehicle system power rating is the sum of the power passing through the reference points.

Figure 25
Example of power determination reference points R1 and R2 for a simple parallel architecture.

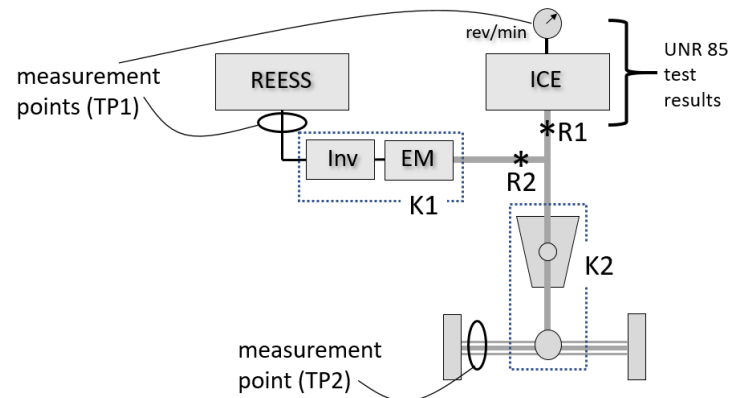

Note: measurement point for TP2 represents both axle shafts.

- 2.2.2. In Figure 25, the electric machine EM directly drives the engine output shaft. The reference points are R1 and R2.
- 2.2.3. Here TP1 may be performed by measuring engine speed, manifold pressure, and fuel flow rate (with reference to the full load power curve) to determine the power at R1, and measuring REESS current and voltage (corrected by K1) to determine the power at R2.
- 2.2.4. TP2 may be performed by measuring the torque and speed at the drive wheels or axle hubs (corrected by K2) to determine the sum of R1 and R2.
- 2.3. Power split architectures
- 2.3.1. Power split architectures (example, Figure 26) often have more than one input and/or output to a complex gearbox that may include one or more planetary gear sets, and may also include a series power conversion path that mixes power from the ICE with power from the REESS. The power determination reference points for such an architecture are generally (a) the engine mechanical power output shaft and (b) the mechanical power output shaft(s) of any electric machines that provide mechanical power to the road. With regard to (b), in the case that the mechanical power delivered by the electric machine includes power sourced from the ICE, only the portion of the power that originates from the REESS is counted ($R2_{REESS}$ in Figure 26). The vehicle system power rating is the sum of the power passing through R1 and $R2_{REESS}$.

Figure 26

Example of power determination reference points R1 and R2_{REESS} for a simple power split architecture.

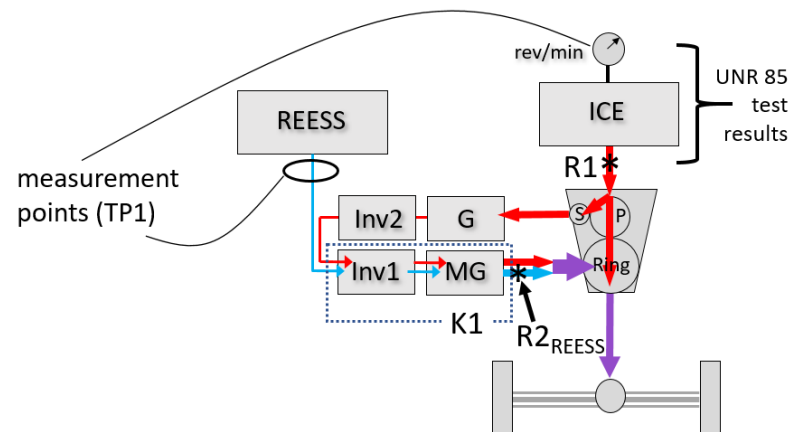

- 2.3.2. Here, TP1 may be performed by measuring engine speed, manifold pressure, and fuel flow rate (with reference to the full load power curve) to determine the power at R1, and measuring REESS current and voltage (corrected by K1) to determine the power at R2_{REESS}. K1 should be chosen to represent the net efficiency of the Inv1+MG combination when transmitting all of the depicted power (of both the series path and the REESS).
- 2.3.3. As indicated by the applicability guidelines under paragraph 8.1.3.2., TP2 is not applicable because the power arriving at the axle is a combination of power flows that experience different conversion efficiencies, making it impractical to reconstruct the power at R1 and R2_{REESS} from a single measurement of axle power.
- 2.4. Pure series architectures
- 2.4.1. Pure series architectures (example, Figure 27) include an ICE that powers one or more electrical conversion paths with no mechanical link between the engine and the road. The power determination reference points are generally (a) the engine mechanical power output shaft and (b) the mechanical power output shaft(s) of any electric machines that provide mechanical power to the road. With regard to (b), in the case that the mechanical power delivered by an electric machine includes power sourced from the ICE, only the portion of the power that originates from the REESS is counted (R2_{REESS}). The vehicle system power rating is the sum of the power passing through R1 and R2_{REESS}.

Figure 27

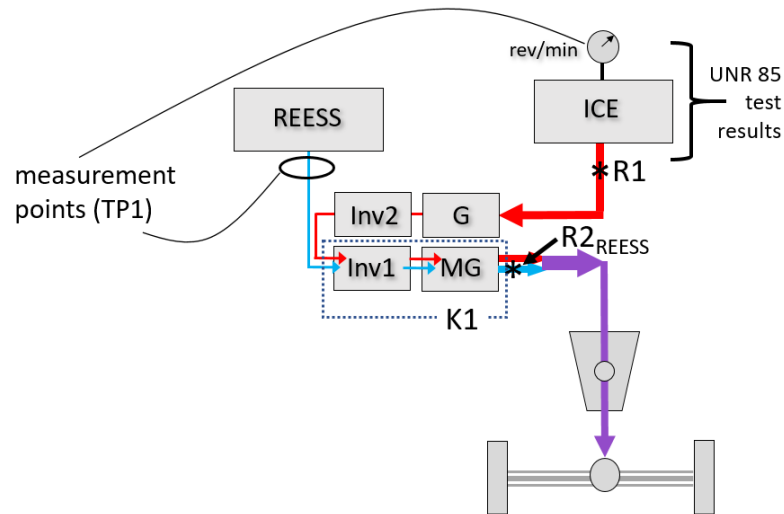
Example of power determination reference points for a pure series architecture

- 2.4.2. Here, TP1 may be performed by measuring engine speed, manifold pressure, and fuel flow rate (with reference to the full load power curve) to determine the power at R1, and measuring REESS current and voltage (corrected by K1) to determine the power at $R2_{REESS}$. K1 should be chosen to represent the net efficiency of the Inv1+MG combination when transmitting all of the depicted power (of both the series path and the REESS).
- 2.4.3. As indicated by the applicability guidelines under 6.1.3.2, TP2 is not applicable because the power arriving at the axle is a combination of power flows that experience different conversion efficiencies, making it impractical to reconstruct the power at R1 and $R2_{REESS}$ from a single measurement of axle power.
- 2.5. Architectures with more than one powered axle
- 2.5.1. When more than one axle propels the vehicle under the maximum power condition, the vehicle must be tested at both axles simultaneously. If each axle is not powered by the same set of propulsion energy converters, there will commonly be reference points associated with a specific axle. An example is shown in Figure 28. Power at R1 and R2 is delivered to one axle while power at R3 is delivered to the other axle. The vehicle system power rating is the sum of the power passing through R1, R2, and R3.

Figure 28

Example of an architecture with more than one powered axle each receiving power through different reference points

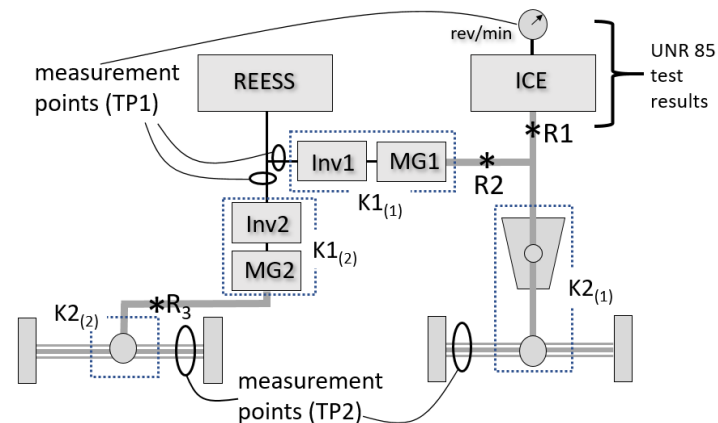

Note: measurement points for TP2 represent both axle shafts.

- 2.5.2. Here, TP1 may be performed by measuring engine speed, manifold pressure, and fuel flow rate (with reference to the full load power curve) to determine the power at R1, and measuring the current and voltage at the input to each of Inv1 and Inv2 (correcting by K1(1) and K1(2), respectively) to determine the power at R2 and R3 (alternatively, instrumentation of the REESS instead of the inverters may be applicable under the conditions described in paragraph 6.1.3.1.).
- 2.5.3. TP2 may be performed by measuring the torque and speed at the right-side axle (corrected by K2(1)) to determine the sum of R1 and R2, and measuring the torque and speed at the left-side axle (corrected by K2(2)) to determine R3.
- 2.6. Other architectures
- 2.6.1. Reference points for other architectures not listed in this Annex, or for variations in the listed architectures, shall be selected in conformity with the definition of power determination reference point in 2.5.3. of this Regulation and in a manner consistent with the principles and guidelines discussed herein. Selection of power determination reference points is subject to approval by the Type-Approval Authority.

Annex 4

Determination of speed of maximum power

1. The speed of maximum power (defined in paragraph 2.5.5. of this Regulation) is the maximum value in the relation between power and speed (see Figure 29), where power is the power delivered to the dynamometer and speed is the speed of the vehicle operating in fixed speed mode on a dynamometer.
2. The speed of maximum power shall be determined either by the manufacturer or the Type-Approval Authority by the procedure described in this Annex.
3. The speed of maximum power shall be identified by conducting the test sequence depicted in Figure 30 at a series of operating points (fixed vehicle speeds) in order to identify the speed at which maximum power occurs.
4. The series of operating points should be spaced closely enough to identify the speed of maximum power with good confidence. The operating points may initially be chosen to cover a range of speeds at a coarse resolution, followed by a finer resolution to identify the speed where peak power is obtained.
5. The power delivered to the dynamometer at each operating point may be determined by reference to dynamometer power data, or dynamometer speed and torque data, where available.
6. Once determined, the speed of maximum power shall be reported in kilometres per hour as a whole number.
7. If the vehicle manufacturer has specified the speed of maximum power and verification is desired, run at slightly different speeds above and below the specified speed to confirm that a peak exists at the specified speed.

Figure 29

Relation between power and speed

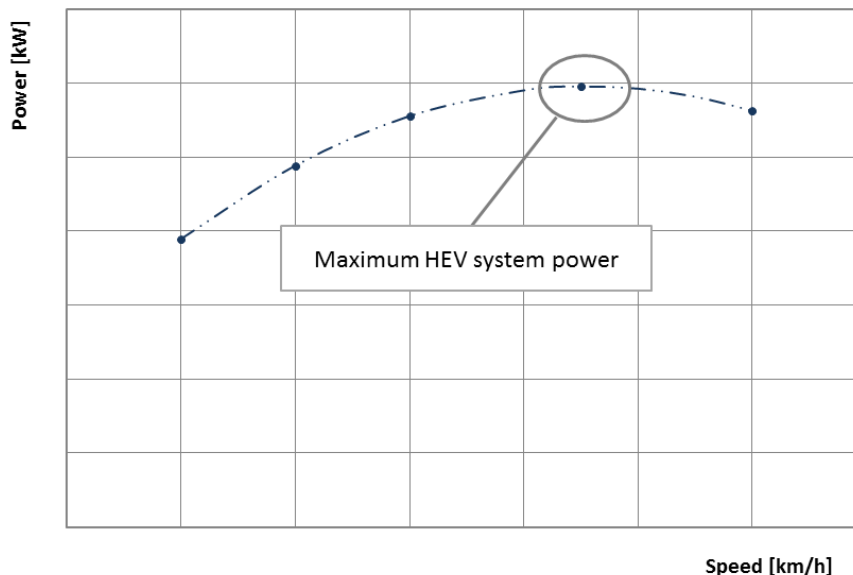
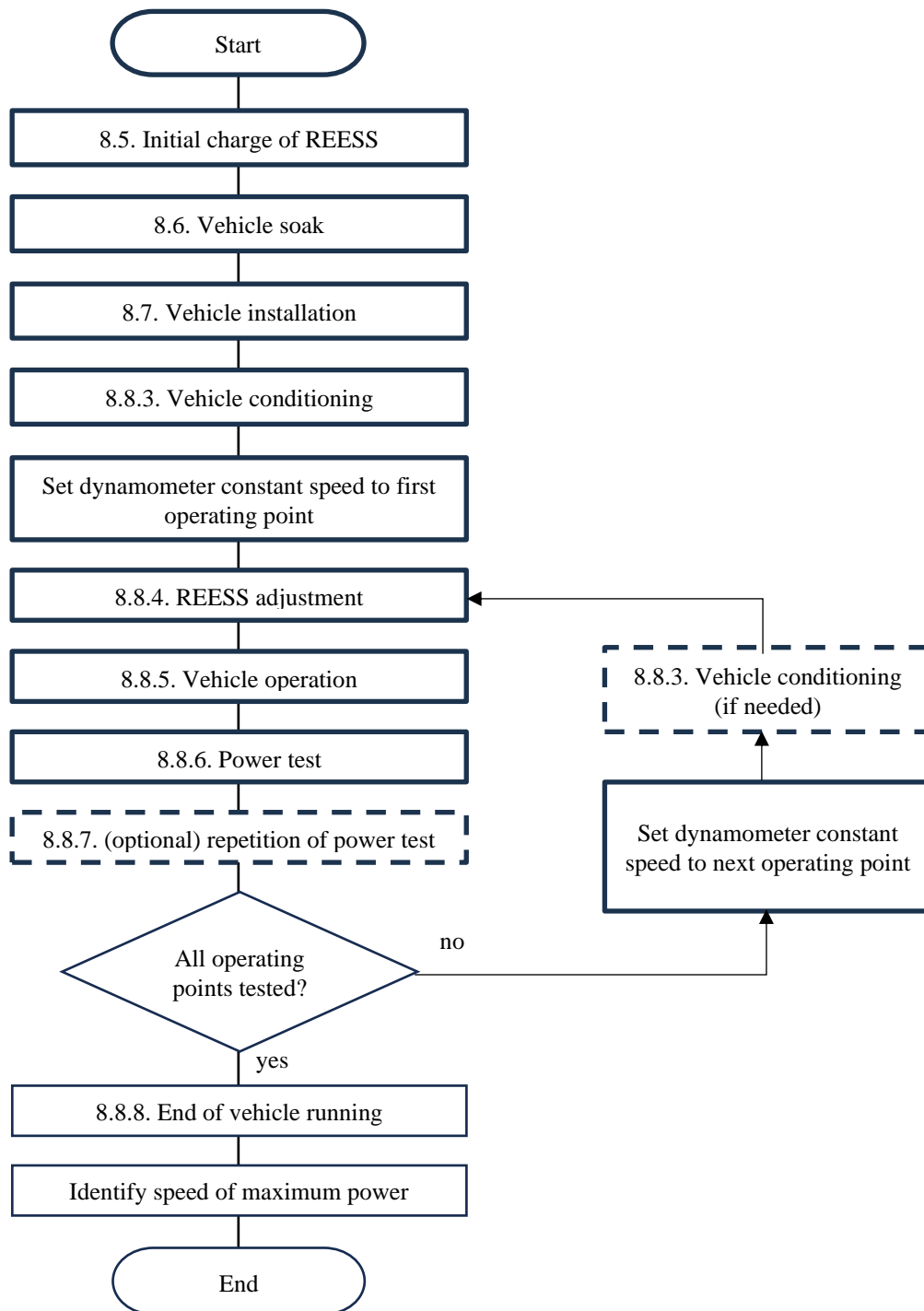

Figure 30
Test sequence for determination of speed of maximum power



II. Justification

1. UN GTR No. 21 on determination of system power of hybrid electric vehicles and of pure electric vehicles having more than one electric machine for propulsion was established in the Global Registry on 11 November 2020.
 2. At the request of OICA, an informal Workshop under GRPE was organised on 23 May 2024.
 3. At this workshop, some Contracting Parties to the 1958 Agreement expressed intentions to transpose the UN GTR into local legislation.
 4. Despite Informal Working Group EVE continuing to develop the content of UN GTR No. 21, it appeared beneficial to commence the transposition of this UN GTR into a UN Regulation.
 5. The Chair of GRPE invited OICA to develop a Working Document proposing a UN Regulation on the basis of UN GTR No. 21 to be considered for adoption at the 91st GRPE Meeting in October 2024.
 6. Additional to the content of the UN GTR, this proposal contains details of approval numbering and marking, approval documentation (communication, manufacturer's information and test report) as well as a statement regarding Conformity of Production.
-