

Proposal for a New UN Regulation on the Installation of safety-belts, restraint systems, child restraint systems, ISOFIX child restraint systems and i-Size child restraint systems

Submitted by the expert from The Netherlands *

The text reproduced below was prepared by the expert from the Netherlands based upon input received from Japan, with the aim to bring this new Regulation more in line with Rev. 3 of the 1958 Agreement. It supersedes working document GRSP/2024/5. The modifications to the working document are marked in bold black for new and strikethrough for deleted characters.

* In accordance with the programme of work of the Inland Transport Committee for 2024 as outlined in proposed programme budget for 2024 (A/78/6 (Sect. 20), table 20.5), the World Forum will develop, harmonize and update UN Regulations in order to enhance the performance of vehicles. The present document is submitted in conformity with that mandate.

I. Proposal

"UN Regulation No. XXX

Uniform provisions concerning the approval of:

the Installation of safety-belts, restraint systems, child restraint systems, ISOFIX child restraint systems and i-Size child restraint systems

Contents

	<i>Page**</i>
Regulation	
0. Introduction.....	
1. Scope.....	
2. Definitions	
3. Application for approval	
4. Approval	
5. Requirements concerning the installation in the vehicle	
6. Conformity of production	
7. Penalties for non-conformity of production	
8. Modifications and extension of approval of the vehicle type or safety-belt or restraint system type.....	
9. Production definitively discontinued.....	
10. Names and addresses of Technical Services responsible for conducting approval tests, and of Type Approval Authorities	
Annexes	
1. Communication concerning the approval or extension or refusal or withdrawal of approval or production definitively discontinued of a vehicle type with regard to the installation of safety-belts, restraint systems, child restraint systems, ISOFIX child restraint systems and i-Size child restraint systems pursuant to UN Regulation No. XXX.....	
2. Arrangements of the approval marks	
3. Instructions.....	
4. Procedure for determining the "H" point and the actual torso angle for seating positions in motor vehicles	
Appendix 1: Description of the three dimensional "H" point machine	
Appendix 2: Three-dimensional reference system	
Appendix 3: Reference data concerning seating positions	
5. Safety-Belt Installation Showing the Belt Types and Retractor Types	

** Page numbers will be added at a later stage.

-
- 6 Requirements for the installation of safety-belts and restraint systems for adult occupants of power-driven vehicles on forward facing seats, for the installation of ISOFIX child restraint systems and i-size child restraint systems
- Appendix 1: Provisions concerning the installation of "universal" category child restraint systems installed with the safety-belt equipment of the vehicle
- Appendix 2: Provisions concerning the installation of forward-facing and rearward-facing ISOFIX child restraint systems of universal and semi-universal categories installed on ISOFIX or i-Size positions
- Appendix 3: Example of detailed information e.g. for child restraint system manufacturers
- Appendix 4: Installation of 10-year manikin.....
- Appendix 5: Provisions concerning the installation of forward-facing booster seat child restraint systems of i-Size and specific categories installed on vehicle seating positions or i-Size seating positions.....

0. Introduction

During the seventy-third session of the Working Party on Passive Safety (GRSP) held in May 2023, it was decided to split UN Regulation No. 16 into three UN Regulations:

- safety-belts and restraint systems (components);
- safety-belts and child restraint systems installation (vehicle);
- safety-belt reminders (vehicle).

This UN Regulation consists of the specific requirements and approval process of a vehicle type with regard to safety-belts and child restraint systems installation. The requirements are derived from UN Regulation No. 16 as amended by the 09 series of amendments. From a technical point of view, the requirements are identical. Therefore, it is important to define clear transitional provisions in the updated UN Regulation No. 16 as amended by the 10 series of amendments, explaining the equivalence between approvals issued according to this Regulation and UN Regulation No. 16 as amended by the 09 series of amendments.

1. Scope

This Regulation applies to:

- 1.1. Vehicles of categories M, N, O, L₂, L₄, L₅, L₆, L₇ and T¹, with regard to the installation of safety-belts and restraint systems which are intended for separate use, i.e. as individual fittings, by persons of adult build occupying forward-facing, rearward-facing and side-facing seats;
- 1.2. Vehicles of categories M₁ and N₁¹ with regard to the installation of child restraint systems and ISOFIX child restraint systems.
- 1.3. At the request of the manufacturer, it also applies to the installation of child restraint systems and ISOFIX child restraint systems designated for installation in vehicles of categories M₂ and M₃.¹
- 1.4. At the request of the manufacturer, it also applies to installing i-Size child restraint systems, in case i-Size seating positions are defined by the vehicle manufacturer.

2. Definitions

- 2.1. "*Safety-belt (seat-belt, belt)*" means an arrangement of straps with a securing buckle, adjusting devices and attachments which is capable of being anchored to the interior of a power-driven vehicle and is designed to diminish the risk of injury to its wearer, in the event of collision or of abrupt deceleration of the vehicle, by limiting the mobility of the wearer's body. Such an arrangement is generally referred to as a "belt assembly", which term also embraces any device for absorbing energy or for retracting the belt.

The arrangement can be tested and approved as a safety-belt arrangement or as a restraint system under UN Regulation No. 16.

- 2.1.1. "*Lap belt*" means a two-point belt which passes across the front of the wearer's pelvic region.

¹ As defined in the Consolidated Resolution on the Construction of Vehicles (R.E.3), document ECE/TRANS/WP.29/78/Rev.7, para. 2 - <https://unece.org/transport/standards/transport/vehicle-regulations-wp29/resolutions>

- 2.1.2. *"Diagonal belt"* means a belt which passes diagonally across the front of the chest from the hip to the opposite shoulder.
- 2.1.3. *"Three-point belt"* means a belt which is essentially a combination of a lap strap and a diagonal strap.
- 2.1.4. *"S-type belt"* means a belt arrangement other than a three-point belt or a lap belt.
- 2.1.5. *"Harness belt"* means an S-type belt arrangement comprising a lap belt and shoulder straps; a harness belt may be provided with an additional crotch strap assembly.
- 2.2. *"Strap"* means a flexible component designed to hold the body and to transmit stresses to the belt anchorages.
- 2.3. *"Buckle"* means a quick-release device enabling the wearer to be held by the belt. The buckle may incorporate the adjusting device, except in the case of a harness belt buckle.
- 2.4. *"Belt adjusting device"* means a device enabling the belt to be adjusted according to the requirements of the individual wearer and to the position of the seat. The adjusting device may be part of the buckle, or a retractor, or any other part of the safety-belt.
- 2.5. *"Pre-loading device"* means an additional or integrated device which tightens the seat-belt webbing in order to reduce the slack of the belt during a crash sequence.
- 2.6. *"Reference zone"* means the space between two vertical longitudinal planes, 400 mm apart and symmetrical with respect to the H-point, and defined by rotation from vertical to horizontal of the head-form apparatus, described in UN Regulation No. 21 Annex 1. The apparatus shall be positioned as described in that annex to UN Regulation No. 21 and set to the maximum length of 840 mm.
- 2.7. *"Airbag assembly"* means a device installed to supplement safety-belts and restraint systems in power-driven vehicles, i.e. system which, in the event of a severe impact affecting the vehicle automatically deploys a flexible structure intended to limit, by compression of the gas contained within it, the gravity of the contacts of one or more parts of the body of an occupant of the vehicle with the interior of the passenger compartment. Any such described deployed structure shall not be considered as a rigid part.
- 2.8. *"Passenger airbag"* means an airbag assembly intended to protect occupant(s) in seats other than the driver's in the event of a frontal collision.
- 2.9. *"Child restraint"* means a safety device as defined in UN Regulation No. 44 or UN Regulation No. 129.
- 2.10. *"Rearward-facing"* means facing in the direction opposite to the normal direction of travel of the vehicle.
- 2.11. *"Attachments"* means parts of the belt assembly including the necessary securing components, which enable it to be attached to the belt anchorages.
- 2.12. *"Retractor"* means a device to accommodate part or the whole of the strap of a safety-belt.
- 2.12.1. *"Non-locking retractor (type 1)"* means a retractor from which the strap is extracted to its full length by a small external force and which provides no adjustment for the length of the extracted strap.
- 2.12.2. *"Manually unlocking retractor (type 2)"* means a retractor requiring the manual operation of a device by the user to unlock the retractor in order to obtain the desired strap extraction and which locks automatically when the said operation ceases.

- 2.12.3. *"Automatically locking retractor (type 3)"* means a retractor allowing extraction of the strap to the desired length and which, when the buckle is fastened, automatically adjusts the strap to the wearer. Further extraction of the strap is prevented without voluntary intervention by the wearer.
- 2.12.4. *"Emergency locking retractor (type 4)"* means a retractor which during normal driving conditions does not restrict the freedom of movement by the wearer of the safety-belt. Such a device has length adjusting components which automatically adjust the strap to the wearer and a locking mechanism actuated in an emergency by:
- 2.12.4.1. Deceleration of the vehicle (single sensitivity).
- 2.12.4.2. A combination of deceleration of the vehicle, movement of the webbing or any other automatic means (multiple sensitivity).
- 2.12.5. *"Emergency locking retractor with higher response threshold (type 4N)"* means a retractor of the type defined in paragraph 2.12.4., but having special properties as regards its use in vehicles of categories M₂, M₃, N₁, N₂ and N₃.²
- 2.12.6. *"Belt adjustment device for height"* means a device enabling the position in height of the upper pillar loop (directly connected to the vehicle or the rigid seat structure) of a belt to be adjusted according to the requirements of the individual wearer and the position of the seat. Such a device may be considered as a part of the belt or a part of the anchorage of the belt.
- 2.12.7. *"Flexible shoulder adjustment device for height"* means a device for adjusting to the shoulder height of the individual wearer, where the adjusting part is not directly attached to the vehicle construction (e.g. pillar) or the seat construction (e.g. the rigid seat structure), but where the adjusting of the shoulder part:
- (a) Is realized via shifting over a flexible construction; and
- (b) Is not interfering the routing of the lap belt.
- 2.13. *"Belt anchorages"* means parts of the vehicles structure or seat structure or any other part of the vehicle to which the safety-belt assemblies are to be secured.
- 2.14. *"Vehicle type with regard to the installation of safety-belts, restraint systems, child restraint systems, ISOFIX child restraint systems and i-Size child restraint systems"* means a category of power-driven vehicles which do not differ in such essential respects as the dimensions, lines and materials of components of the vehicle structure or seat structure or any other part of the vehicle to which the safety-belts, the restraint systems and the ISOFIX anchorages are attached.
- 2.15. *"Restraint system"* means a system for a specific vehicle type or a type defined by the vehicle manufacturer and agreed by the Technical Service consisting of a seat and a belt fixed to the vehicle by appropriate means and consisting additionally of all elements which are provided to diminish the risk of injury to the wearer, in the event of an abrupt vehicle deceleration, by limiting the mobility of the wearer's body.
- 2.16. *"Seat"* means a structure which may or may not be integral with the vehicle structure complete with trim, intended to seat one adult person. The term covers both an individual seat or part of a bench seat intended to seat one person.
- 2.16.1. *"A front passenger seat"* means any seat where the "foremost H-point" of the seat in question is in or in front of the vertical transverse plane through the driver's R-point.

² As defined in the Consolidated Resolution on the Construction of Vehicles (R.E.3), document ECE/TRANS/WP.29/78/Rev.7, para. 2 - <https://unece.org/transport/standards/transport/vehicle-regulations-wp29/resolutions>

- 2.16.2. "*Forward-facing seat*" means a seat which can be used while the vehicle is in motion and which faces towards the front of the vehicle in such a manner that the vertical plane of symmetry of the seat forms an angle of less than $+10^\circ$ or -10° with the vertical plane of symmetry of the vehicle.
- 2.16.3. "*Rearward-facing seat*" means a seat which can be used while the vehicle is in motion and which faces towards the rear of the vehicle in such a manner that the vertical plane of symmetry of the seat forms an angle of less than $+10^\circ$ or -10° with the vertical plane of symmetry of the vehicle.
- 2.16.4. "*Side-facing seat*" means a seat which can be used while the vehicle is in motion and which faces towards the side of the vehicle in such a manner that the vertical plane of symmetry of the seat forms an angle of 90° ($\pm 10^\circ$) with the vertical plane of symmetry of the vehicle.
- 2.17. "*Group of seats*" means either a bench-type seat or seats which are separate but side by side (i.e. fixed so that front seat anchorages of one of these seats are in line with the front of the rear anchorages of the other or between the anchorages of the other seat) and accommodate one or more seated adult persons.
- 2.18. "*Bench seat*" means a structure complete with trim, intended to seat more than one adult person.
- 2.19. "*Adjustment system of the seat*" means the complete device by which the seat or its parts can be adjusted to a position suited to the morphology of the seated occupant; this device may, in particular, permit of:
- 2.19.1. Longitudinal displacement;
- 2.19.2. Vertical displacement;
- 2.19.3. Angular displacement.
- 2.20. "*Seat anchorage*" means the system by which the seat assembly is secured to the vehicle structure, including the affected parts of the vehicle structure.
- 2.21. "*Seat type*" means a category of seats which do not differ in such essential respects as:
- 2.21.1. The shape, dimensions and materials of the seat structure;
- 2.21.2. The types and dimensions of the seat lock adjustment and locking systems;
- 2.21.3. The type and dimensions of the belt anchorage on the seat, of the seat anchorage and of the affected parts of the vehicle structure.
- 2.22. "*Displacement system of the seat*" means a device enabling the seat or one of its parts to be displaced angularly or longitudinally, without a fixed intermediate position (to facilitate access by passengers).
- 2.23. "*Locking system of the seat*" means a device ensuring that the seat and its parts are maintained in any position of use.
- 2.24. "*Tension-reducing device*" means a device which is incorporated in the retractor and reduces the tension of the strap automatically when the safety-belt is fastened. When it is released, such a device switches off automatically.
- 2.25. "*ISOFIX*" is a system for the connection of child restraint systems to vehicles which has two vehicle rigid anchorages, two corresponding rigid attachments on the child restraint system, and a mean to limit the pitch rotation of the child restraint system.
- 2.26. "*ISOFIX child restraint system*" means a child restraint system, fulfilling the requirements of UN Regulation No. 44 or UN Regulation No. 129, which has to be attached to an ISOFIX anchorages system, fulfilling the requirements of UN Regulation No. 14 or UN Regulation No. 145.
- 2.27. "*ISOFIX position*" means a system which allows installing:

- (a) Either a universal ISOFIX forward facing child restraint system as defined in UN Regulation No. 44;
 - (b) Or a semi-universal ISOFIX forward facing child restraint system as defined in UN Regulation No. 44;
 - (c) Or a semi-universal ISOFIX rearward facing child restraint system as defined in UN Regulation No. 44;
 - (d) Or a semi-universal ISOFIX lateral facing position child restraint system as defined in UN Regulation No. 44;
 - (e) Or a specific vehicle ISOFIX child restraint system as defined in UN Regulation No. 44;
 - (f) Or an i-Size child restraint system as defined in UN Regulation No. 129;
 - (g) Or a specific vehicle ISOFIX child restraint system as defined in UN Regulation No. 129.
- 2.28. "*ISOFIX Anchorages System*" means a system made up of two ISOFIX low anchorages, fulfilling the requirements of UN Regulation No. 14 or UN Regulation No. 145, and which is designed for attaching an ISOFIX child restraint system in conjunction with an anti-rotation device.
- 2.29. "*ISOFIX low anchorage*" means one 6 mm diameter rigid round horizontal bar, extending from vehicle or seat structure to accept and restrain an ISOFIX child restraint system with ISOFIX attachments.
- 2.30. "*Anti-rotation device*"
- (a) An anti-rotation device for an ISOFIX universal child restraint system consists of the ISOFIX top-tether;
 - (b) An anti-rotation device for an ISOFIX semi-universal child restraint system consists of a top tether, the vehicle dashboard or a support leg intended to limit the rotation of the restraint during a frontal impact;
 - (c) An anti-rotation device for an i-Size Enhanced Child Restraint System consists of either a top tether or a support leg, which is intended to limit the rotation of the restraint during a frontal impact;
 - (d) An anti-rotation device for a "specific vehicle" (Enhanced) Child Restraint System may comprise a top tether, a support leg, lower tether strap(s) or, any other means capable of limiting the rotation;
 - (e) For ISOFIX, i-Size, universal and semi-universal, (Enhanced) Child Restraint Systems the vehicle seat itself does not constitute an anti-rotation device.
- 2.31. "*ISOFIX Top Tether Anchorage*" means a feature, fulfilling the requirements of UN Regulation No. 14 or UN Regulation No. 145, such as a bar, located in a defined zone, designed to accept an ISOFIX top tether strap connector and transfer its restraint force to the vehicle structure.
- 2.32. A "*guidance device*" is intended to help the person installing the ISOFIX child restraint system by physically guiding the ISOFIX attachments on the ISOFIX child restraint into correct alignment with the ISOFIX low anchorages to facilitate engagement.
- 2.33. "*ISOFIX marking fixture*" means something that informs someone wishing to install an ISOFIX child restraint system of the ISOFIX positions in the vehicle and the position of each corresponding ISOFIX anchorages system.
- 2.34. "*Child restraint fixture (CRF)*" means a fixture according to one of the ISOFIX fixtures defined in paragraph 4 of Annex 6 - Appendix 2 of this Regulation, and particularly whose dimensions are given from Figure 1 to Figure 8 in the

previous mentioned paragraph 4. Those child restraint fixtures (CRF) are used, in this Regulation, to check which ISOFIX child restraint systems size envelopes classes mentioned in UN Regulation No. 44 or in UN Regulation No. 129 can be accommodated on the vehicle ISOFIX positions. Also one of the CRF, the so-called ISO/F2, which is described in Figure 2 of the previous mentioned paragraph 4, is used in UN Regulation No. 14 or UN Regulation No. 145 to check the location and the possibility of access to any ISOFIX anchorages system.

Or a fixture, according to one of the two "booster seat" fixtures defined in Annex 6, Appendix 5 of this Regulation, and particularly whose dimensions are given in Figures 2 and 3 of Annex 6, Appendix 5. These fixtures are used, in this Regulation, to check which booster seat size envelopes mentioned in UN Regulation No. 129 can be accommodated on vehicle seating positions, if any.

- 2.35. *"i-Size support leg installation assessment volume"* means a volume, which ensures the dimensional and geometrical compatibility between the support leg of an i-Size child restraint system and an i-Size seating position of a vehicle.
- 2.36. *"i-Size seating position"* means a seating position, if any defined by the vehicle manufacturer, which is designed to accommodate i-Size child restraint systems, as defined in UN Regulation No. 129, and fulfils the requirements defined in this Regulation.
- 2.37. *"Lower tether anchorage (LTA)"*: anchorage on the vehicle seat track or on or close to the vehicle floor to which a lower tether bracket can be attached or is integrated. The lower tether bracket may or may not be part of the vehicle approval.
- 2.38. *"Lower tether"*: type of anti-rotation device intended to restrict the rearward rotation of a rearward-facing (E)CRS.
- 2.39. *"Lower tether strap"*: a webbing strap (or equivalent) which extends from the back of a Specific Vehicle (E)CRS to the lower tether anchorage in the vehicle and which is equipped with an adjustment device, a tensioning-relieving device, and a lower tether connector.
- 2.40. *"Lower tether connector"* means a device intended to be attached to a lower tether bracket.
- 2.41. *"Lower tether hook"* means a connector typically used to attach a lower tether strap to a lower tether bracket and which is the same and has the same dimensions as the ISOFIX top tether hook as defined in figure 3 of Annex 4 of UN Regulation No. 145.
- 2.42. *"Lower tether bracket"* means the bracket that is attached to or integrated with the lower tether anchorage.
- 2.43. *"Generic lower tether bracket"* means the generic bracket provided by the ECRS manufacturer together with the ECRS, to be attached to the LTA as indicated by the vehicle manufacturer.

3. Application for approval

- 3.1. The application for approval of a vehicle type with regard to the installation of safety-belts, restraint systems, child restraint systems, ISOFIX child restraint systems and i-Size child restraint systems, shall be submitted by the vehicle manufacturer or by his duly accredited representative **in accordance with the procedure set out in Schedule 3 of the Agreement (E/ECE/TRANS/505/Rev.3).**

- 3.2. It shall be accompanied by the under mentioned documents and the following particulars:
- 3.2.1. Drawings of the general vehicle structure on an appropriate scale, showing the positions of the safety-belts and ISOFIX anchorages, and detailed drawings of the safety-belts and ISOFIX anchorages and of the points to which they are attached;
- 3.2.2. A specification of the materials used which may affect the strength of the safety-belts;
- 3.2.3. A technical description of the safety-belts;
- 3.2.4. In the case of safety-belts affixed to the seat structure:
- 3.2.4.1. Detailed description of the vehicle type with regard to the design of the seats, of the seat anchorages and their adjustment and locking systems;
- 3.2.4.2. Drawings, on an appropriate scale and in sufficient detail, of the seats, of their anchorages to the vehicle, and of their adjustment and locking systems.
- 3.3. A vehicle representative of the vehicle type to be approved **incl. the vehicle's owner's manual** shall be submitted to the Technical Service.

4. Approval

- ~~4.1. A certificate conforming to the model specified in Annex 1 shall be attached to the type approval certificate:~~
- 4.1. If the vehicle submitted for approval pursuant this Regulation meets the requirements of ~~paragraph 5. below~~ **this Regulation**, approval of that vehicle type shall be granted.
- 4.2. An approval number shall be assigned to each type approved **in accordance with Schedule 4 of the Agreement (E/ECE/TRANS/505/Rev.3)**. ~~Its first two digits (00 for this Regulation in its initial form) shall indicate the series of amendments incorporating the most recent major technical amendments made to this Regulation at the time of issue of the approval. The same Contracting Party shall not assign the same number to another vehicle type as defined in paragraph 2.14. above.~~
- 4.3. Notice of approval or of extension or refusal or withdrawal of approval or production definitively discontinued of a vehicle type pursuant to this Regulation shall be communicated to the Parties to the 1958 Agreement which apply this Regulation by means of a form conforming to the model in Annex 1 to this Regulation.
- 4.4. There shall be affixed, conspicuously and in a readily accessible place specified on the approval form, to every vehicle conforming to a vehicle type approved under this Regulation an international approval mark consisting of:
- 4.4.1. A circle surrounding the letter "E" followed by the distinguishing number of the country which has granted approval;³
- 4.4.2. The number of this Regulation, followed by the letter R, a dash and the approval number to the right of the circle prescribed in paragraph 4.4.1. above.
- 4.5. **If the vehicle conforms to a vehicle type approved, under one or more other Regulations annexed to the Agreement, in the country which has granted approval under this Regulation, the symbol prescribed in**

³ The distinguishing numbers of the Contracting Parties to the 1958 Agreement are reproduced in Annex 3 to the Consolidated Resolution on the Construction of Vehicles (R.E.3), document ECE/TRANS/WP.29/78/Rev.7, Annex 3 - <https://unece.org/transport/standards/transport/vehicle-regulations>

paragraph 4.4.1. above need not be repeated; in such a case the Regulation and approval numbers and the additional symbols of all the Regulations under which approval has been granted in the country which has granted approval under this Regulation shall be placed in vertical columns to the right of the symbol prescribed in paragraph 4.4.1.

- 4.6. The approval mark shall be clearly legible and be indelible.
- 4.7. The approval mark shall be placed close to or on the vehicle data plate affixed by the manufacturer.
- 4.8. Annex 2 to this Regulation gives an example of the arrangement of the approval mark.

5. Requirements concerning the installation in the vehicle

5.1. Safety-belt and restraint systems equipment

- 5.1.1. With the exception of seating intended solely for use when the vehicle is stationary, the seats of vehicles of categories M₁, M₂ (of Class III or B⁴), M₃ (of Class III or B⁸) and N shall be equipped with safety-belts or restraint systems which satisfy the requirements of this Regulation.

Contracting Parties applying this Regulation may demand the installation of safety belts on M₂ and M₃ vehicles belonging to Class II.

When fitted, the safety belts and/or restraint systems in Class I, II or A vehicles belonging to category M₂ or M₃ have to be in compliance with the requirements of this Regulation.

Contracting Parties may, under national law, allow the installation of safety belts or restraint systems other than those covered by this Regulation provided that they are intended for disabled people.

Restraint systems complying with the provisions of Annex 8 of the 02 series of amendments to UN Regulation No. 107 are exempted from the provisions of this Regulation.

Class I, or A vehicles belonging to category M₂ or M₃ may be fitted with safety belts and/or restraint systems conforming to the requirements of this Regulation.

Only vehicles belonging to category M₂ or M₃ may be fitted with restraint systems comprising a flexible shoulder adjustment device for height (paragraph 2.12.7.).

- 5.1.2. The types of safety-belts or restraint systems for each seating position where installation is required shall be those specified in Annex 5 (with which neither non-locking retractors (paragraph 2.12.1.) nor manually unlocking retractor (paragraph 2.12.2.) can be used). For all seating positions where lap belts type B are specified in Annex 5 lap belts type Br3 are permitted except in the case that, in use, they retract to such an extent as to reduce comfort in a notable way after normal buckling up.
- 5.1.2.1. However, for outboard seating positions, other than front, of vehicles of the category N₁ shown in Annex 5 and marked with the symbol Ø, the installation of a lap belt of type Br4m or Br4Nm is allowed, where there exists a passage between a seat and the nearest side wall of the vehicle intended to permit access of passengers to other parts of the vehicle. A space between a seat and the side

⁴ As defined in the Consolidated Resolution on the Construction of Vehicles (R.E.3), document ECE/TRANS/WP.29/78/Rev.7, para. 2 - <https://unece.org/transport/standards/transport/vehicle-regulations-wp29/resolutions>

wall is considered as a passage, if the distance between that side wall, with all doors closed, and a vertical longitudinal plane passing through the centre line of the seat concerned – measured at the R-point position and perpendicularly to the median longitudinal plane of the vehicle – is more than 500 mm.

- 5.1.3. Where no safety-belts are required any type of safety-belt or restraint system conforming to this Regulation may be provided at the choice of the manufacturer. A-type belts of the types permitted in Annex 5 may be provided as an alternative to lap belts for those seating positions where lap belts are specified in Annex 5.
- 5.1.4. On three point belts fitted with retractors, one retractor shall operate at least on the diagonal strap.
- 5.1.5. Except for vehicles of category M₁ an emergency locking retractor of type 4N (paragraph 2.12.5.) may be permitted instead of a retractor of type 4 (paragraph 2.12.4.) where it has been shown to the satisfaction of the services responsible for the tests that the fitting of a type 4 retractor would not be practical.
- 5.1.6. For the front outboard and the front centre seating positions shown in Annex 5 and marked with the symbol *, lap belts of the type specified on that annex shall be considered adequate where the windscreen is located outside the reference zone defined in Annex 1 to UN Regulation No. 21.
- As regards safety-belts, the windscreen is considered as part of the reference zone when it is capable of entering into static contact with the test apparatus according to the method described in Annex 1 of UN Regulation No. 21.
- 5.1.7. Every seating position in Annex 5 marked with the symbol ●, three-point belts of a type specified in Annex 5 shall be provided unless one of the following conditions is fulfilled, in which case two-point belts of a type specified in Annex 5 may be provided.
- 5.1.7.1. There is a seat or other vehicle parts conforming to paragraph 3.5. of Appendix 1 to UN Regulation No. 80 directly in front; or
- 5.1.7.2. No part of the vehicle is in or, when the vehicle is in motion, capable of being in the reference zone; or
- 5.1.7.3. Parts of the vehicle within the said reference zone comply with the energy absorbing requirements set out in Appendix 6 of UN Regulation No. 80.
- 5.1.7.4. Paragraphs 5.1.7.1. to 5.1.7.3. shall not apply to a driver's seat.
- 5.1.8. For M₂ and M₃ vehicles of all classes, forward-facing seats facing Built-in Child Restraint Systems shall be equipped with at least Ar seat belts.
- 5.1.9. The vehicle shall carry information to the effect that it is equipped with frontal protection airbags for seats.
- 5.1.9.1 For a vehicle fitted with an airbag assembly intended to protect the driver, this information shall consist of the inscription "AIRBAG" located in the interior of the circumference of the steering wheel; this inscription shall be durably affixed and easily visible
- 5.1.9.2 Every passenger seating position which is fitted with a frontal protection airbag, shall be provided with a warning against the use of a rearward-facing child restraint in that seating position. This information shall consist of a label containing clear warning pictograms as indicated below:

Figure 1
Warning label

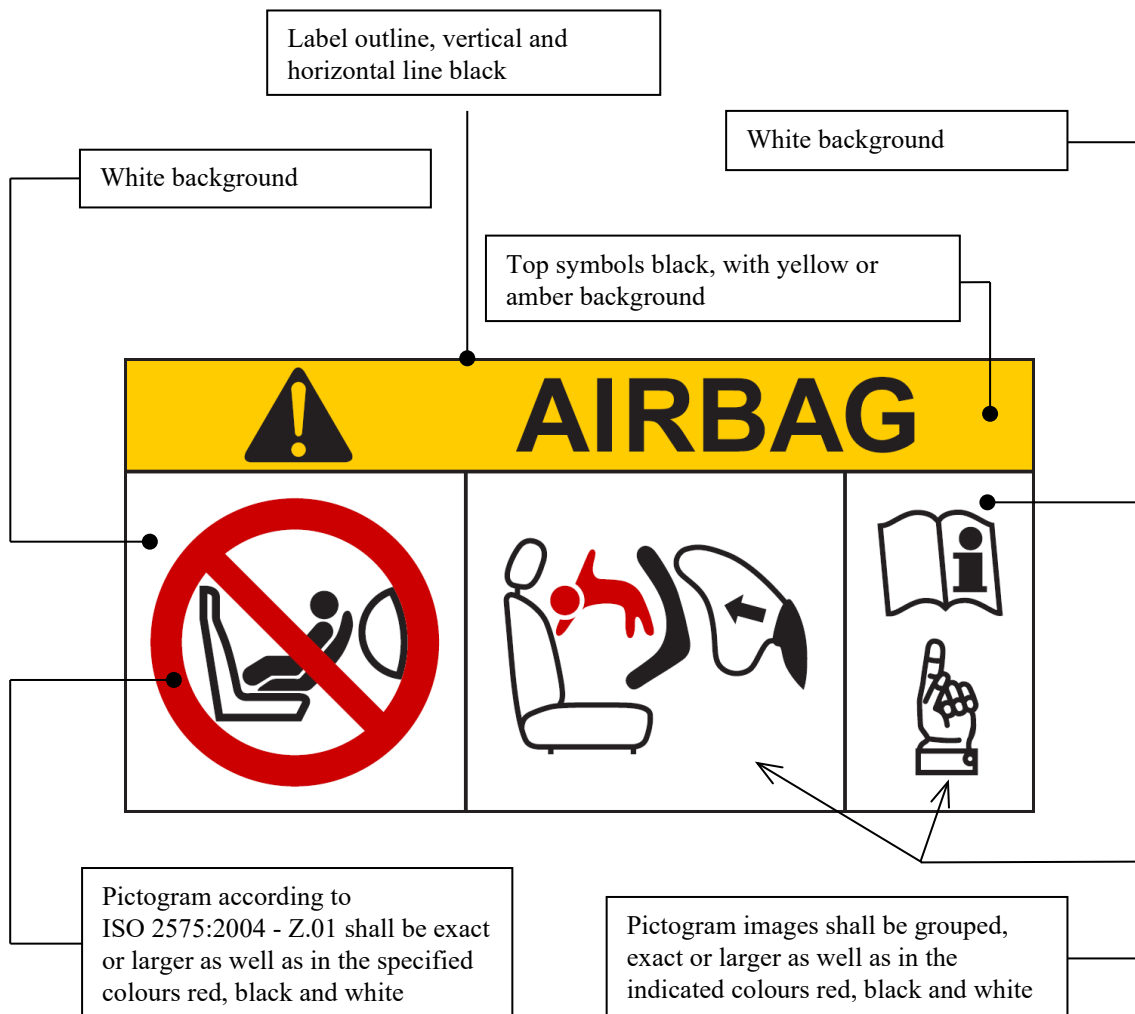

The overall dimensions of the label shall be at least 120 x 60 mm or the equivalent area.

The label may be adapted in such a way that the layout differs from the example shown here; however, the content shall meet the precise prescriptions. Furthermore, no other type of information shall be included on the label unless it is placed outside a clearly marked rectangle with at least the overall dimensions as required above. In derogation to the aforementioned, a part number, bar code or similar identification mark not exceeding 8 mm x 35 mm or the equivalent area may be placed on the label.

It shall also be ensured that no deviations in the shape and orientation of the provided pictograms are permitted, notably that any customised appearance of the prescribed pictogram images shall be prohibited, with the exception of the hand with pointing index finger and the open face booklet with letter 'i' on its right page provided that they are clearly recognisable as such.

Small irregularities concerning line thickness, label imprinting and other relevant production tolerances shall be accepted.

Figure 2

Pictogram according to ISO 2575:2004 - Z.01 that shall be used and that shall have an outer diameter of at least 38 mm



Figure 3

Pictogram depicting airbag deployment danger that shall be used and that shall measure 40 mm in width and 28 mm in height or proportionally larger



"

5.1.9.3. In the case of a frontal protection airbag placed before the front passenger seats, the warning shall be durably affixed to each face of the passenger front sun visor in such a position that at least one warning on the sun visor is visible at all times, irrespective of the position of the sun visor. Alternatively, one warning shall be located on the visible face of the stowed sun visor and a second warning shall be located on the roof behind the visor, so, at least one warning is visible all times. It shall not be possible to easily remove the warning label from the visor and the roof without any obvious and clearly visible damage remaining to the visor or the roof in the interior of the vehicle.

If the vehicle does not have a sun visor or roof, the warning label shall be positioned in a location where it is clearly visible at all times.

In the case of a frontal protection airbag for other passenger seats in the vehicle, the warning shall be directly ahead of the relevant seat, and clearly visible at all times to someone installing a rear-facing child restraint on that seat. This paragraph and paragraph 5.1.9.2. do not apply to those passenger seating positions equipped with a device which automatically deactivates the frontal protection airbag assembly when any rearward facing child restraint is installed.

5.1.9.4. Detailed information, ... as a minimum, this information shall include at least the following text:

"NEVER use a rearward facing child restraint on a seat protected by an ACTIVE AIRBAG in front of it, DEATH or SERIOUS INJURY to the CHILD can occur" ⁵

⁵ Unrelated to type approval, Contracting Parties may specify in which languages the text shall be provided with each vehicle placed on the market at the point of sale within their territory.

The text shall be accompanied by an illustration of the warning label as found in the vehicle. The information shall be easily found in the owner's manual (e.g. specific reference to the information printed on the first page, identifying page tab or separate booklet, etc.).

The requirements of this paragraph do not apply to vehicles of which all passenger seating positions are equipped with a device which automatically deactivates the frontal protection airbag assembly when any rearward facing child restraint is installed.

- 5.1.10. In the case of seats capable of being turned to or placed in other orientations, designed for use when the vehicle is stationary, the requirements of paragraph 5.1.1. above shall only apply to those orientations designated for normal use when the vehicle is travelling on a road, in accordance with this Regulation.
- 5.2. General requirements
- 5.2.1. Safety-belts, restraint systems, and ISOFIX child restraint systems, as well as i-Size child restraint systems according to Annex 6, Appendix 3, shall be fixed to anchorages and in case of i-Size child restraint systems, supported by a vehicle floor contact surface, conforming to the specifications of UN Regulation No. 14 or UN Regulation No. 145, such as the design and dimensional characteristics, the number of anchorages, and the strength requirements.
- 5.2.2. The safety-belts, restraint systems and child restraint systems recommended by the manufacturer according to Annex 6 – Appendix 3, shall be so installed that they will work satisfactorily and reduce the risk of bodily injury in the event of an accident. In particular, they shall be so installed that:
- 5.2.2.1. The straps are not liable to assume a dangerous configuration;
- 5.2.2.2. The danger of a correctly positioned belt slipping from the shoulder of a wearer as a result of his/her forward movement is reduced to a minimum;
- 5.2.2.3. The risk of the strap deteriorating through contact with sharp parts of the vehicle or seat structure, and child restraint systems recommended by the manufacturer according to Annex 6 – Appendix 3, is reduced to a minimum.
- 5.2.2.4. The design and installation of every safety-belt provided for each seating position shall be such as to be readily available for use. Furthermore, where the complete seat or the seat cushion and/or the seat back can be folded to permit access to rear of the vehicle or to goods or luggage compartment, after folding and restoring those seats to the seating position, the safety-belts provided for those seats shall be accessible for use or can be easily recovered from under or behind the seat, by one person, according to instructions in the vehicle users handbook, without the need for that person to have training or practice;
- 5.2.2.5. The Technical Service shall verify that, with the buckle tongue engaged in the buckle:
- 5.2.2.5.1. The possible slack in the belt does not prevent the correct installation of child restraint systems recommended by the manufacturer, and
- 5.2.2.5.2. In the case of three-point belts, a tension of at least 50 N can be established in the lap section of the belt by external application of tension in the diagonal section of the belt, when positioned:
- (a) On a 10-year manikin as specified in Annex 8, Appendix 1 to UN Regulation No. 44 and set in accordance with Annex 6, Appendix 4 to the present Regulation;

- (b) Or on the fixture specified in Annex 6, Appendix 1, Figure 1 to the present Regulation for the seats that enable the installation of a child restraint device of universal category.
- 5.3. Special requirements for rigid parts incorporated in safety-belts or restraint systems
- 5.3.1. Rigid parts, such as the buckles, adjusting devices and attachments, shall not increase the risk of bodily injury to the wearer or to other occupants of the vehicle in the event of an accident.
- 5.3.2. The device for releasing the buckle shall be clearly visible to the wearer and within his easy reach and shall be so designed that it cannot be opened inadvertently or accidentally. The buckle shall also be located in such a position that it is readily accessible to a rescuer needing to release the wearer in an emergency.
- The buckle shall be so installed that, both when not under load and when sustaining the wearer's mass, it is capable of being released by the wearer with a single simple movement of either hand in one direction.
- In the case of a safety-belts or restraint systems for front outboard seating positions, except if these are harness belts, the buckle shall also be capable of being locked in the same manner.
- A check shall be made to ensure that, if the buckle is in contact with the wearer, the width of the contact surface is not less than 46 mm.
- A check shall be made to ensure that, if the buckle is in contact with the wearer, the contact surface satisfies the requirements of paragraph 6.2.2.1. of UN Regulation No. 16.
- 5.3.3. When the belt is being worn, it shall either adjust automatically to fit the wearer or be so designed that the manual adjusting device is readily accessible to the wearer when seated and is convenient and easy to use. It shall also be possible for it to be tightened with one hand to suit the build of the wearer and the position of the vehicle seat.
- 5.3.4. Safety-belts or restraint systems incorporating retractors shall be so installed that the retractors are able to operate correctly and stow the strap efficiently. In case of both a belt adjusting device and a flexible shoulder adjustment device for height, in at least their highest and their lowest position, checks shall be made that the retractor automatically adjusts the strap to the shoulder of the concerned wearer after buckling, as well as that the tongue-plate rolls up in case of an unbuckling.
- 5.3.5. In order to inform vehicle user(s) of the provisions made for the transport of children, vehicles of Categories M₁, M₂, M₃ and N₁ shall meet the information requirements of Annex 6. Any vehicle of Category M₁ shall be equipped with ISOFIX positions, in accordance with the relevant prescriptions of UN Regulation No. 14 or UN Regulation No. 145.
- The first ISOFIX position shall allow at least the installation of one out of the three forward-facing fixtures as defined in Appendix 2 of Annex 6; the second ISOFIX position shall allow at least the installation of one rear-facing fixture as defined in Appendix 2 of Annex 6. For this second ISOFIX position, in case where the installation of the rear-facing fixture is not possible on the second row of seats of the vehicle due to its design, the installation of one fixture is allowed in any position of the vehicle.
- 5.3.6. Any i-Size seating position shall allow the installation of the ISOFIX child restraint fixture "ISO/F2X", "ISO/R2", and the support leg installation assessment volume as defined in Appendix 2 of Annex 6, as well as the booster seat fixture "ISO/B2" as defined in Appendix 5 of Annex 6, without the ISOFIX attachments (see detail B). It shall be possible to occupy all adjacent

i-Size seating positions simultaneously. This is deemed to be demonstrated when the vertical median planes of individual adjacent positions are at least 440 mm apart.

- 5.4. **Vehicle types of categories M, N, O, L2, L4, L5, L6, L7 and T approved to UN Regulation No. 16, 08 series of amendments before 1 September 2026 or 09 series of amendments before 1 September 2027 are deemed to comply with this paragraph 5.**

6. **Conformity of production**

The conformity of production procedures shall comply with those set out in the Agreement, Schedule 1 (E/ECE/TRANS/505/Rev.3), with the following requirements:

- 6.1. Every vehicle type approved under this Regulation shall be so manufactured as to conform to the type approved by meeting the requirements set forth in paragraph 5 above.
- 6.2. ~~The Type Approval Authority which has granted type approval may at any time verify the conformity control methods applied in each production facility. The normal frequency of these verifications shall be twice a year.~~

7. **Penalties for non-conformity of production**

- 7.1. The approval granted in respect of a vehicle **type pursuant to this Regulation** may be withdrawn if the requirement laid down in paragraph 6.1. above is not complied with.
- 7.2. If a Contracting Party to the Agreement applying this Regulation withdraws an approval it has previously granted, it shall forthwith so notify the other Contracting Parties applying this Regulation by means of a communication form conforming to the model in Annex 1 to this Regulation.

8. **Modifications and extension of approval of the vehicle type**

- 8.1. Every modification of the vehicle type ~~which affects its technical performance and/or documentation as required in~~ **with regard to** this Regulation shall be notified to the Type Approval Authority which approved the vehicle type. The **Type Approval** Authority may then either:

- (a) **Decide, in consultation with the manufacturer, that a new type approval is to be granted; or**
- (b) **Apply the procedure contained in paragraph 8.1.1. (Revision) and, if applicable, the procedure contained in paragraph 8.1.2. (Extension).**

8.1.1. **Revision**

When particulars recorded in the information documents have changed and the Type Approval Authority considers that the modifications made are unlikely to have appreciable adverse effect, and that in any case the vehicle still meets the requirements, the modification shall be designated a "revision".

In such a case, the Type Approval Authority shall issue the revised pages of the information documents as necessary, marking each revised page to show clearly the nature of the modification and the date of re-issue. A consolidated, updated version of the information documents,

accompanied by a detailed description of the modification, shall be deemed to meet this requirement.

8.1.2. Extension

The modification shall be designated an "extension" if, in addition to the change of the particulars recorded in the information folder:

- (a) Further inspections or tests are required; or
- (b) Any information on the communication document (with the exception of its attachments) has changed; or
- (c) Approval to a later series of amendments is requested after its entry into force.

8.2. Notice of confirmation, extension, or refusal of approval shall be communicated by the procedure specified in paragraph 4.3. above, to the Contracting Parties to the Agreement applying this Regulation. In addition, the index to the information documents and to the test reports, attached to the communication document of Annex 1, shall be amended accordingly to show the date of the most recent revision or extension.

8.3. The Type Approval Authority issuing the extension of approval shall assign a series number to each communication form drawn up for such an extension.

~~8.1.1. Consider that the modifications made are unlikely to have an appreciable adverse effect and that in any case the vehicle still complies with the requirements; or~~

~~8.1.2. Require a further test report from the Technical Service responsible for conducting the tests.~~

~~8.2. Without prejudice to the provisions of paragraph 8.1. above, a variant of the vehicle whose mass in the running order is less than that of the vehicle subjected to the approval test shall not be regarded as a modification of the vehicle type.~~

~~8.3. Confirmation or refusal of approval, specifying the alterations, shall be communicated by the procedure specified in paragraph 4.4. of this Regulation to the Parties to the Agreement applying this Regulation.~~

~~8.4. The Type Approval Authority issuing the extension of approval shall assign a series number for such an extension and inform thereof the other parties to the 1958 Agreement applying this Regulation by means of a communication form conforming to the model in Annex 1 to this Regulation.~~

9. Production definitively discontinued

If the holder of the approval completely ceases to manufacture a device approved in accordance with this Regulation, he shall so inform the Type Approval Authority which granted the approval. Upon receiving the relevant communication that Authority shall inform thereof the other Parties to the 1958 Agreement applying this Regulation by means of a communication form conforming to the model in Annex 1 to this Regulation.

10. Names and addresses of Technical Services responsible for conducting approval tests and of Type Approval Authorities

The Contracting Parties to the 1958 Agreement applying this Regulation shall communicate to the Secretariat of the United Nations Secretariat the names

and addresses of the Technical Services responsible for conducting approval tests and of the Type Approval Authorities which grant approval and to which forms certifying approval or refusal or extension or withdrawal of approval, issued in other countries, are to be sent.

Annex 1

Communication

(Maximum format: A4 (210 x 297 mm))

issued by: Name of administration:
.....
.....
.....



1
Concerning:² Approval granted
Approval extended
Approval refused
Approval withdrawn
Production definitively discontinued

of a vehicle type with regard to the installation of safety-belts, restraint systems, child restraint systems, ISOFIX child restraint systems and i-Size child restraint systems pursuant to UN Regulation No. XXX.

- Approval No.
- 1. General
- 1.1. Make (trade name of manufacturer)
- 1.2. Type and general commercial description(s)
- 1.3. Means of identification of type, if marked on the vehicle
-
- 1.3.1. Location of that marking
- 1.4. Category of vehicle
- 1.5. Name and address of manufacturer
- 1.6. Address(es) of assembly plant(s)
- 1.7. Technical Service responsible for carrying out the test
- 1.8. Date of test report
- 1.9. Number of test report
- 2. General construction characteristics of the vehicle
- 2.1. Photographs and/or drawings of a representative vehicle
- 3. Bodywork
- 3.1. Seats
- 3.1.1. Number

¹ Distinguishing number of the country which has granted/extended/refused/withdrawn approval (see approval provisions in the Regulation).
² Strike out what does not apply.

- 3.1.2. Position and arrangement
- 3.1.2.1. Seating position(s) designated for use only when the vehicle is stationary
- 3.1.3. Characteristics: description and drawings of:
 - 3.1.3.1. The seats and their anchorages
 - 3.1.3.2. The adjustment system
 - 3.1.3.3. The displacement and locking systems.....
 - 3.1.3.4. The seat belt anchorages if incorporated in the seat structure.....
- 3.2. Safety-belts and/or other restraint systems
 - 3.2.1. Number and position of safety-belts and restraint systems and seats on which they can be used

		<i>Complete type approval mark</i>	<i>Variant (if applicable)</i>	<i>Belt adjustment device for height (indicate yes/no/optional)</i>
First row of seats	R			
	C			
	L			
Second row of seats	R			
	C			
	L			
(R = right-hand seats, C = centre seats, L = left hand seats)				

- 3.2.2. Nature and position of supplementary restraint systems (indicate yes/no/optional).

		<i>Front airbag</i>	<i>Side airbag</i>	<i>Belt preloading device</i>
First row of seats	R			
	C			
	L			
Second row of seats	R			
	C			
	L			
(R = right-hand seats, C = centre seats, L = left hand seats)				

- 3.2.3. Number and position of safety-belt anchorages and proof of compliance with UN Regulation No. 14 (i.e. type approval number or test report).
- 3.3. ISOFIX Anchorages
 - 3.3.1. Number and position of ISOFIX anchorages and proof of compliance with UN Regulation No. 14 or 145 (i.e. type approval number or test report).
- 4. Place
- 5. Date.....
- 6. Signature.....

Annex 2

Arrangements of approval marks

(see paragraphs 4.5. to 4.5.2. of this Regulation)



a = 8 mm min.

The above approval mark affixed to a vehicle shows that the vehicle type concerned was approved in the Netherlands (E4) pursuant to UN Regulation No. XXX under approval No. 001234. The first two digits (00) of the approval number indicate that the approval was granted in accordance with the requirements of UN Regulation No. XXX in its original form.

Annex 3

Instructions

1. User instructions (may be included in the vehicle user's handbook if the safety-belt is installed by the vehicle manufacturer) which specify the instructions to ensure that the user obtains the greatest benefit from the safety-belt. In these instructions reference shall be made to:
 - (a) The importance of wearing the assembly on all journeys;
 - (b) The correct manner of wearing the belt and in particular to:
 - (i) The intended location of the buckle;
 - (ii) The desirability of wearing belts tightly;
 - (iii) The correct positioning of the straps and the need to avoid twisting them;
 - (iv) The importance of each belt being used by one occupant only, and especially of not putting a belt around a child seated on the occupant's lap;
 - (c) The method of operating the buckle;
 - (d) The method of operating the adjuster;
 - (e) The method of operating any retractor which may be incorporated in the assembly and the method of checking that it locks;
 - (f) The recommended methods of cleaning the belt and reassembling it after cleaning where appropriate;
 - (g) The need to replace the safety-belt when it has been used in a severe accident or shows signs of severe fraying or having been cut, or when, with a belt fitted with a visual overload indicator, it indicates the belt's unsuitability for further use or when a seat-belt is equipped with a pre-loading device, when the latter has been activated;
 - (h) The fact that the belt shall not be altered or modified in any way since such changes may render the belt ineffective, and in particular where the design permits part to be disassembled, instructions or ensure correct reassembly;
 - (i) The fact that the belt is intended for use by adult-sized occupants;
 - (j) The stowage of the belt when not in use.

Annex 4

Procedure for determining the "H" point and the actual torso angle for seating positions in motor vehicles¹

Appendix 1 - Description of the three dimensional "H" point machine¹

Appendix 2 - Three-dimensional reference system¹

Appendix 3 - Reference data concerning seating positions¹

¹ The procedure is described in Addendum 6 of Mutual Resolution No. 1 (M.R.1) (document ECE/TRANS/WP.29/1101/Amend.5); see <https://unece.org/transport/vehicle-regulations/wp29/resolutions>

Annex 5

Safety-Belt Installation Showing the Belt Types and Retractor Types

Minimum requirements for safety-belts and Retractors						
Vehicle category	Forward facing seating positions				Rearward-facing seating positions	Side-facing seating position
	Outboard seating positions		Centre seating position			
	Front	Other than front	Front	Other than front		
M ₁	Ar4m	Ar4m	Ar4m	Ar4m	B, Br3, Br4m	-
M ₂ < 3.5 t	Ar4m, Ar4Nm	Ar4m, Ar4Nm	Ar4m, Ar4Nm	Ar4m, Ar4Nm	Br3, Br4m, Br4Nm	-
M ₂ > 3.5 t	Br3, Br4m, Br4Nm, or Ar4m or Ar4Nm ●	Br3, Br4m, Br4Nm, or Ar4m or Ar4Nm ●	Br3, Br4m, Br4Nm or Ar4m or Ar4Nm ●	Br3, Br4m, Br4Nm or Ar4m or Ar4Nm ●	Br3, Br4m, Br4Nm	-
M ₃	Br3, Br4m, Br4Nm, or Ar4m or Ar4Nm ● See para. 5.1.7. for conditions when a lap belt is permitted	Br3, Br4m, Br4Nm, or Ar4m or Ar4Nm ● See para. 5.1.7. for conditions when a lap belt is permitted	Br3, Br4m, Br4Nm or Ar4m or Ar4Nm ● See para. 5.1.7. for conditions when a lap belt is permitted	Br3, Br4m, Br4Nm or Ar4m or Ar4Nm ● See para. 5.1.7. for conditions when a lap belt is permitted	Br3, Br4m, Br4Nm	B, Br3, Br4m, Br4Nm
N ₁	Ar4m, Ar4Nm	Ar4m, Ar4Nm, Br4m, Br4Nm Ø	B, Br3, Br4m, Br4Nm or A, Ar4m, Ar4Nm* Para. 5.1.6. lap belt permitted if the windscreen is not in the reference zone	B, Br3, Br4m, Br4Nm	B, Br3, Br4m, Br4Nm	-
N ₂	Br3, Br4m, Br4Nm or Ar4m, Ar4Nm* Para. 5.1.6. lap belt permitted if the windscreen is outside the reference zone and for the driver's seat	B, Br3, Br4m, Br4Nm	B, Br3, Br4m, Br4Nm, or A, Ar4m, Ar4Nm* Para. 5.1.6. lap belt permitted if the windscreen is not in the reference zone	B, Br3, Br4m, Br4Nm	B, Br3, Br4m, Br4Nm	-
N ₃	Br3, Br4m, Br4Nm or Ar4m, Ar4Nm* Para. 5.1.6. lap belt permitted if the windscreen is outside the reference zone and for the driver's seat	B, Br3, Br4m, Br4Nm	B, Br3, Br4m, Br4Nm, or A, Ar4m, Ar4Nm* Para. 5.1.6. lap belt permitted if the windscreen is not in the reference zone	B, Br3, Br4m, Br4Nm	B, Br3, Br4m, Br4Nm	-

A: three-point (lap and diagonal) belt

B: 2-point (lap) belt

r: retractor

m: emergency locking retractor with multiple sensitivity

3: automatically locking retractor

4: emergency locking retractor

N: higher response threshold

(see paras. 2.12.3. and 2.12.5. of this Regulation)

*: Refers to para. 5.1.6. of this Regulation

Ø: Refers to para. 5.1.2.1. of this Regulation

●: refers to para. 5.1.7. of this Regulation

Note a: In all cases all S-type belts may be fitted in place of all possible A or B type belts, provided their anchorages comply with UN Regulation No. 14.

Where a harness belt has been approved as a S-type belt according to this Regulation, using the lap belt strap, the shoulder belt straps and possibly one or more retractors, one or two additional crotch straps including their attachments for their anchorages may be provided by the manufacturer/applicant. These additional anchorages need not meet the requirements of UN Regulation No. 14

Note b: For M₂ and M₃ vehicles of all classes, forward facing Seats facing Built in Child Restraint Systems shall be equipped with at least Ar seat belts. "

Annex 6

Requirements for the installation of safety-belts and restraint systems for adult occupants of power-driven vehicles on forward facing seats, for the installation of ISOFIX child restraint systems and i-size child restraint systems

1. Compatibility with child restraint systems
- 1.1. The vehicle manufacturer shall include in the vehicle handbook, simple advice to the vehicle user on the suitability of each passenger seating position for the fitting of child restraint systems. This information shall be given by pictograms or in the national language, or at least one of the national languages, of the country in which the vehicle is offered for sale.

For each forward-facing passenger seating position, and for each specified ISOFIX position, the vehicle manufacturer shall indicate:

- (a) If the seating position is suitable for child restraints of the "universal" category (see paragraph 1.2. below); and/or
- (b) If the seating position is suitable for i-size child restraint systems (see paragraph 1.4. below); and/or
- (c) If the seating position is suitable for child restraint systems equipped with lower tether attachments; and/or
- (d) If the seating position is suitable for child restraint systems other than those specified above (e.g. see paragraph 1.3. below).

If a seating position is only suitable for use with forward-facing child restraint systems, this shall also be indicated in the vehicle handbook.

In addition to the above information for the vehicle user, the vehicle manufacturers shall make available the information as defined by Appendix 3 of this annex. For example, this information can be included in separate annexes of the vehicle handbook, or in technical descriptions of the vehicle or on a dedicated webpage. The location to access this information shall be provided in the vehicle handbook.

- 1.2. A child restraint system of the universal category means a child restraint approved to the "universal" category of UN Regulation No. 44, 04 series of amendments or to one of the universal categories of UN Regulation No. 129 (or subsequent amendments). Positions, which are indicated by the vehicle manufacturer as being suitable for the installation of child restraints systems of the universal category shall comply with the provisions of Appendix 1 and Appendix 5 to this annex.
- 1.3. An ISOFIX child restraint means a child restraint approved to UN Regulation No. 44, Supplement 5 to 03 series of amendments or to UN Regulation No. 129 (or subsequent amendments). Positions, which are indicated by the vehicle manufacturer as being suitable for the installation of ISOFIX child restraints systems shall comply with the provisions of Appendix 2 to this annex.
- 1.4. An i-Size child restraint means a child restraint approved to the i-Size category of UN Regulation No. 129. Seating positions, which are indicated by the vehicle manufacturer as being suitable for the installation of i-Size child restraints systems shall comply with the provisions of Appendix 2 and Appendix 5 to this annex.

Annex 6 - Appendix 1

Provisions concerning the installation of "universal" category child restraint systems installed with the safety-belt equipment of the vehicle

1. General
 - 1.1. The test procedure and the requirements in this appendix shall be used to determine the suitability of seating positions for the installation of child restraints of the "universal" category.
 - 1.2. The tests may be carried out in the vehicle or in a representative part of the vehicle.
2. Test procedure
 - 2.1. Adjust the seat to its fully rearward and lowest position.
 - 2.2. Adjust the seat-back angle to the manufacturer's design position. In the absence of any specification, an angle of 25 degrees from the vertical, or the nearest fixed position of the seat-back, should be used.
 - 2.3. Set the shoulder anchorage to the lowest position.
 - 2.4. Place a cotton cloth on the seat-back and cushion.
 - 2.5. Place the fixture (as described in Figure 1 of this appendix) on the vehicle seat.
 - 2.6. If the seating position is intended to accommodate a forward-facing or rearward-facing universal restraint system, proceed according to paragraphs 2.6.1., 2.7., 2.8., 2.9. and 2.10. below. If the seating position is intended to accommodate only a forward-facing universal restraint system, proceed according to paragraphs 2.6.2., 2.7., 2.8., 2.9. and 2.10. below.
 - 2.6.1. Arrange the safety-belt strap around the fixture in approximately the correct position as shown in Figures 2 and 3, then latch the buckle.
 - 2.6.2. Arrange the safety-belt lap strap approximately in the correct position around the lower part of the fixture of 150 mm radius as shown in Figure 3, then latch the buckle.
 - 2.7. Ensure that the fixture is located with its vertical plane of symmetry within ± 25 mm of the vertical plane of symmetry of the seating position.
 - 2.8. Ensure that all webbing slack is removed. Use sufficient force to remove the slack, do not attempt to tension the webbing.
 - 2.9. Push rearwards on the centre of the front of the fixture with a force of $100 \text{ N} \pm 10 \text{ N}$, applied parallel to the lower surface, and remove the force.
 - 2.10. Push vertically downwards on the centre of the upper surface of the fixture with a force of $100 \text{ N} \pm 10 \text{ N}$, and remove the force.
3. Requirements
 - 3.1. The base of the fixture shall contact both the forward and rearward parts of the seat cushion surface. If such contact does not occur due to the belt access gap in the test fixture, this gap may be covered in line with the bottom surface of the test fixture.
 - 3.2. The lap portion of the belt shall touch the fixture on both sides at the rear of the lap belt path (see Figure 3). The seat belt webbing shall always cover the points BP on the left and right ends of the curved edge; the exact position of point BP on the curved edge is indicated in detail W of Figure 1.

- 3.3. Should the above requirements not be met with the adjustments indicated in paragraphs 2.1., 2.2. and 2.3. above, the seat, seat-back and safety-belt anchorages may be adjusted to an alternative position designated by the manufacturer for normal use at which the above installation procedure shall be repeated and the requirements again verified and met. This alternative position shall be included as an information in the Table 1 given in Appendix 3 to this annex.

1. Figure 1
Specifications of the fixture (all dimensions in mm)

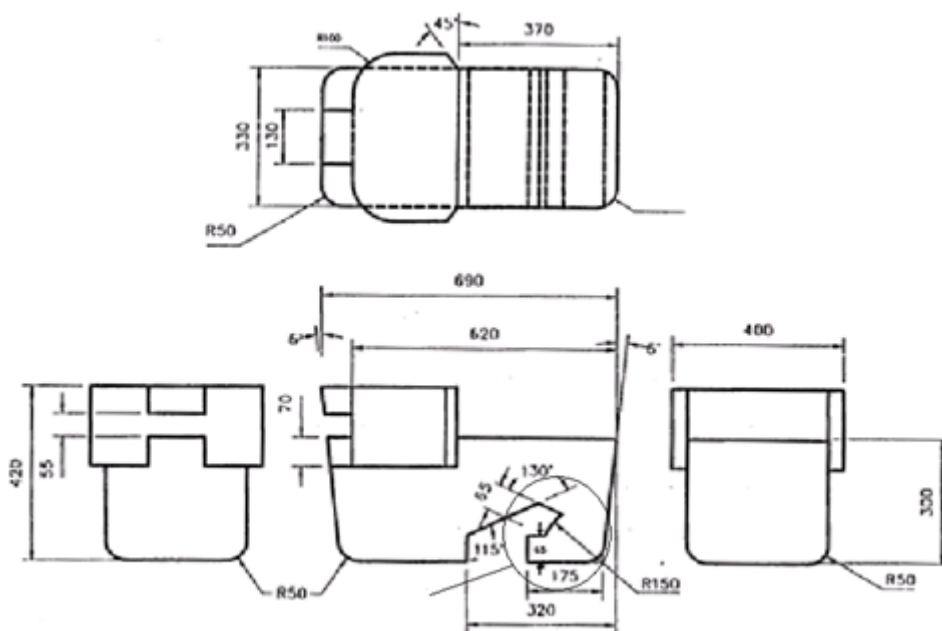

Weight 23kg evenly distributed

2.

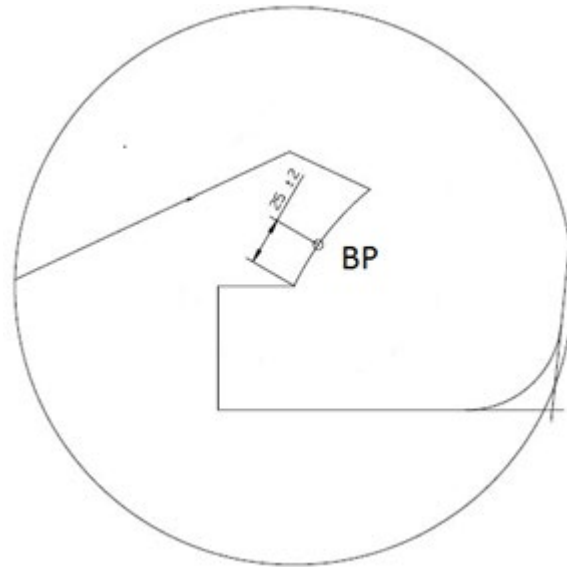

Detail W

Figure 2
Installation of fixture onto vehicle seat
(see paragraph 2.6.1.)

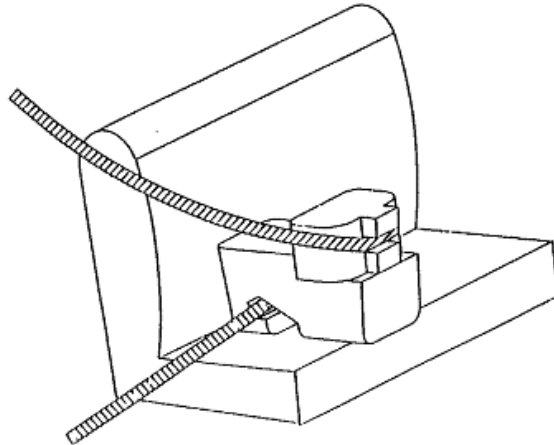
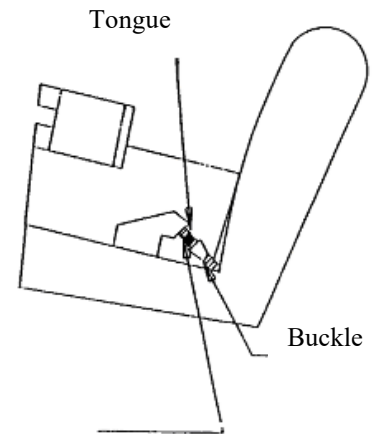

Figure 3
Check for compatibility
(see paragraphs 2.6.1. and 3.2)



Lap belt only shown

- 3.
- 4.
- 5. Detail W to Figure 1

Annex 6 - Appendix 2

Provisions concerning the installation of forward-facing and rearward-facing ISOFIX child restraint systems of universal and semi-universal categories installed on ISOFIX or i-Size positions

1. General
 - 1.1. The test procedure and the requirements in this appendix shall be used to determine the suitability of ISOFIX positions for the installation of ISOFIX child restraint systems of universal and semi-universal categories, as well as to determine the suitability of i-Size seating positions for installing i-Size child restraint systems.
 - 1.2. A child restraint system of the universal category means a child restraint approved to the "universal" category of UN Regulation No. 44, Supplement 5 to 03 series of amendments (or subsequent amendments). Seating positions, which are indicated by the vehicle manufacturer as being suitable for the installation of child restraints systems of the universal category shall comply with the provisions of Appendix 1 to this annex.
2. Test procedure

ISOFIX positions in the vehicle, defined by the vehicle manufacturer shall be checked to ensure that the CRF listed in paragraph 4. of this Appendix can be accommodated. Where the vehicle manufacturer has indicated that the ISOFIX position(s) will accommodate a particular CRF, then it shall be assumed that smaller CRFs of the same orientation may be accommodated.

i-Size seating positions, defined by the vehicle manufacturer, shall be checked to ensure that it is possible to accommodate both the ISO/R2 and the ISO/F2X child restraint fixtures (see paragraph 4. of this annex) including the i-Size support leg installation assessment volume.

For both, ISOFIX and i-size position(s), the following procedure shall apply:

 - 2.1. When checking a CRF, on a seat, with or without i-Size support leg installation assessment volume, this seat may be adjusted longitudinally to its rearmost position and in its lowest position.
 - 2.2. Adjust the seat-back angle to the manufacturer's design position and the head restraint in the lowest and rearmost position. In the absence of any specification an angle of the seat-back corresponding to a torso angle of 25° from the vertical, or the nearest fixed position of the seat-back, shall be used.

When checking a CRF, on a rear seat, with or without i-Size support leg installation assessment volume, the vehicle seat located in front of this rear seat may be adjusted longitudinally forward but not further than the mid position between its rearmost and fore most positions. The seat backrest angle may also be adjusted, but not to a more upright angle than corresponding to a torso angle of 15°.
 - 2.3. Place a cotton cloth on the seat-back and cushion.
 - 2.4. Place the CRF, with or without i-Size support leg installation assessment volume, on the ISOFIX or i-Size position.
 - 2.5. Push, towards ISOFIX anchorages system, on the center between the ISOFIX anchorages with a force of 100 N ± 10 N, applied parallel to the lower surface, and remove the force.

- 2.6. Attach the CRF, with or without i-Size support leg installation assessment volume, to the ISOFIX anchorages system.
- 2.7. Push vertically downwards on the centre of the upper surface of the fixture with a force of $100\text{ N} \pm 10\text{ N}$, and remove the force.
3. Requirements
- The following testing conditions only apply for the CRF(s), with or without i-Size support leg installation assessment volume, when accommodated in the ISOFIX and/or i-Size position. It is not required that the CRF(s), with or without i-Size support leg installation assessment volume, shall be able to move in and out of the ISOFIX and/or i-Size position under these conditions.
- 3.1. It has to be possible to accommodate the CRF(s), with or without i-Size support leg installation assessment volume, without interference with the vehicle interior. The CRF base shall have a pitch angle of $15^\circ \pm 10^\circ$, above the horizontal plane passing through the ISOFIX anchorages system. ISOFIX attachments, according to detail Y of Figures 1 to 9, may adjust longitudinally between -10 mm to +70 mm to facilitate the interference check. The figures are showing the most extended positions.
- 3.2. The ISOFIX top tether anchorage, if any, shall remain accessible.
- 3.3. Should the above requirements not be met with the adjustments indicated in paragraph 2. above, the seats, the seat-backs, the head restraints may be adjusted to alternative positions designated by the manufacturer for normal use following which the above installation procedure shall be repeated and the requirements verified and met. These alternative positions shall be described in the vehicle handbook and with the additional information specified in Appendix 3 to this annex. Passenger seats in front of i-Size seating positions may also be displaced to a position forward of the normal position of use. In such cases, the vehicle manufacturer shall provide information in the vehicle handbook, that the respective passenger seat shall not be occupied in such positions of displacement.
- 3.4. Should the above requirements not be fulfilled when some removable interior fittings were present, such fittings may be removed and then requirements of paragraph 3. have to be verified again and fulfilled. In such a case corresponding information shall be included in Table 2 and/or 3 of Appendix 3 of this annex.
4. ISOFIX child restraint system size envelope fixtures:
- ISO/F3: Full-Height Forward Facing toddler CRS
 - ISO/F2: Reduced-Height Forward Facing toddler CRS
 - ISO/F2X: Reduced-Height Forward Facing toddler CRS
 - ISO/R3: Full-Size Rearward Facing toddler CRS
 - ISO/R2: Reduced-Size Rearward Facing toddler CRS
 - ISO/R2X: Reduced-Size Rearward Facing toddler CRS
 - ISO/R1: Rearward Facing infant CRS
 - ISO/L1: Left Lateral Facing position CRS (carry-cot)
 - ISO/L2: Right Lateral Facing position CRS (carry-cot)
- The fixtures above shall be constructed with a mass between 10 and/or 13 kg +/- 1 kg and shall be of suitable durability and stiffness to satisfy the functional requirements, following the table below:

CRF	Mass (kg)	Tolerance (kg)
R1 ^a	10	± 1
R2 / R2X ^a	10	± 1
R3	13	± 1
L1 / L2	13	± 1
F2 / F2X ^a	13	± 1
F3	13	± 1

^a ISOFIX base mass taken into account.

4.1. Full-height forward-facing toddler child restraint systems envelope

6. Figure 1

ISO/F3 envelope dimensions for a full-height forward-facing toddler CRS (height 720 mm) ISOFIX SIZE CLASS A

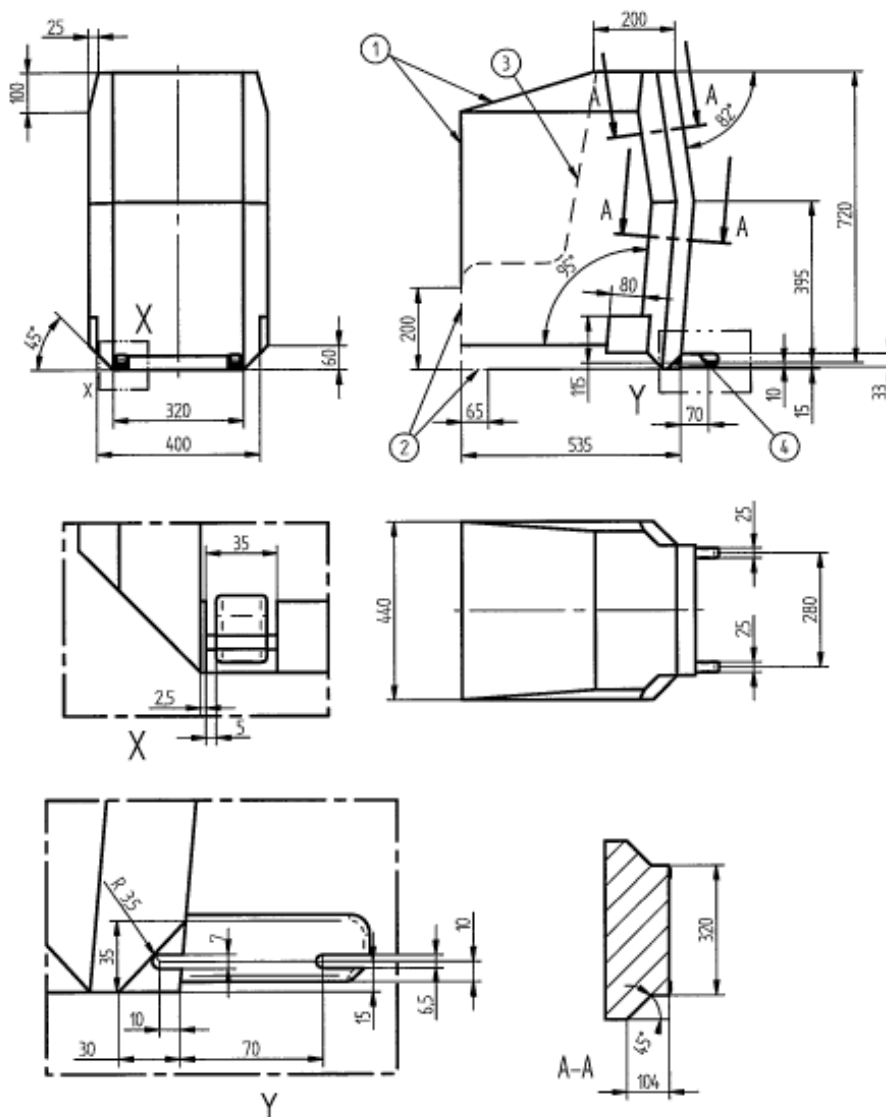

Key:

- 1 Limits in the forward and upwards directions
- 2 Dashed line marks area where a support leg, or similar, of a specific vehicle CRS is allowed to protrude.
- 3 N/A
- 4 Further specifications of the connector area are given in UN Regulation No. 44

4.2. Reduced-height forward-facing toddler child restraint systems envelope

7. Figure 2

ISO/F2 envelope dimensions for a reduced-height forward-facing toddler CRS, (height 650 mm) – ISOFIX SIZE CLASS B

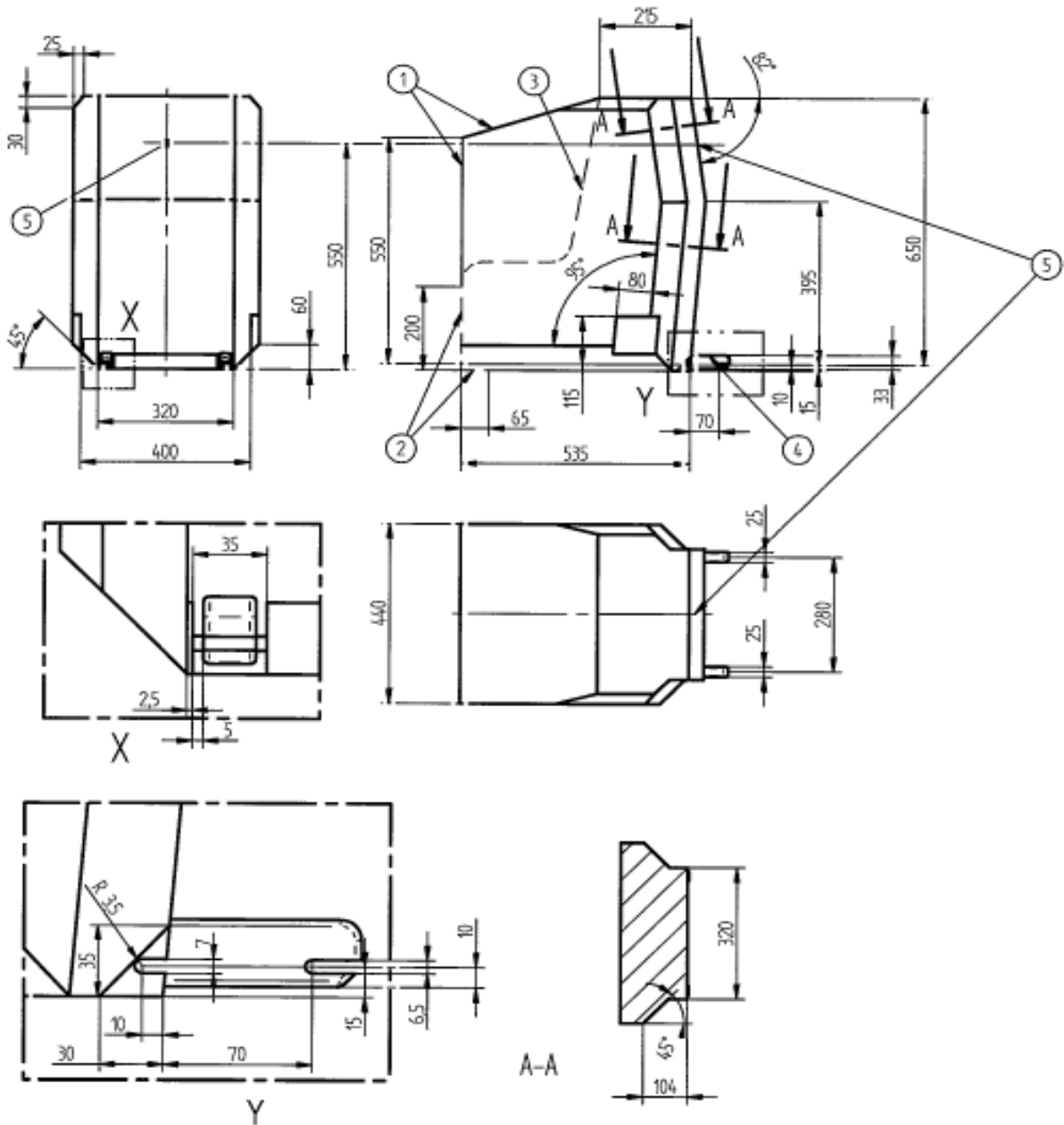

Key:

- 1 Limits in the forward and upwards directions
- 2 Dashed line marks area where a support leg, or similar, of a specific vehicle CRS is allowed to protrude.
- 3 N/A
- 4 Further specifications of the connector area are given in UN Regulation No. 44
- 5 Attachment point for the top tether strap.

- 4.3. Reduced-height second version back shape forward-facing toddler child restraint systems envelope

8. Figure 3

ISO/F2X envelope dimensions for a reduced-height second version back surface shape forward-facing toddler CRS, (height 650 mm) – ISOFIX SIZE CLASS B1

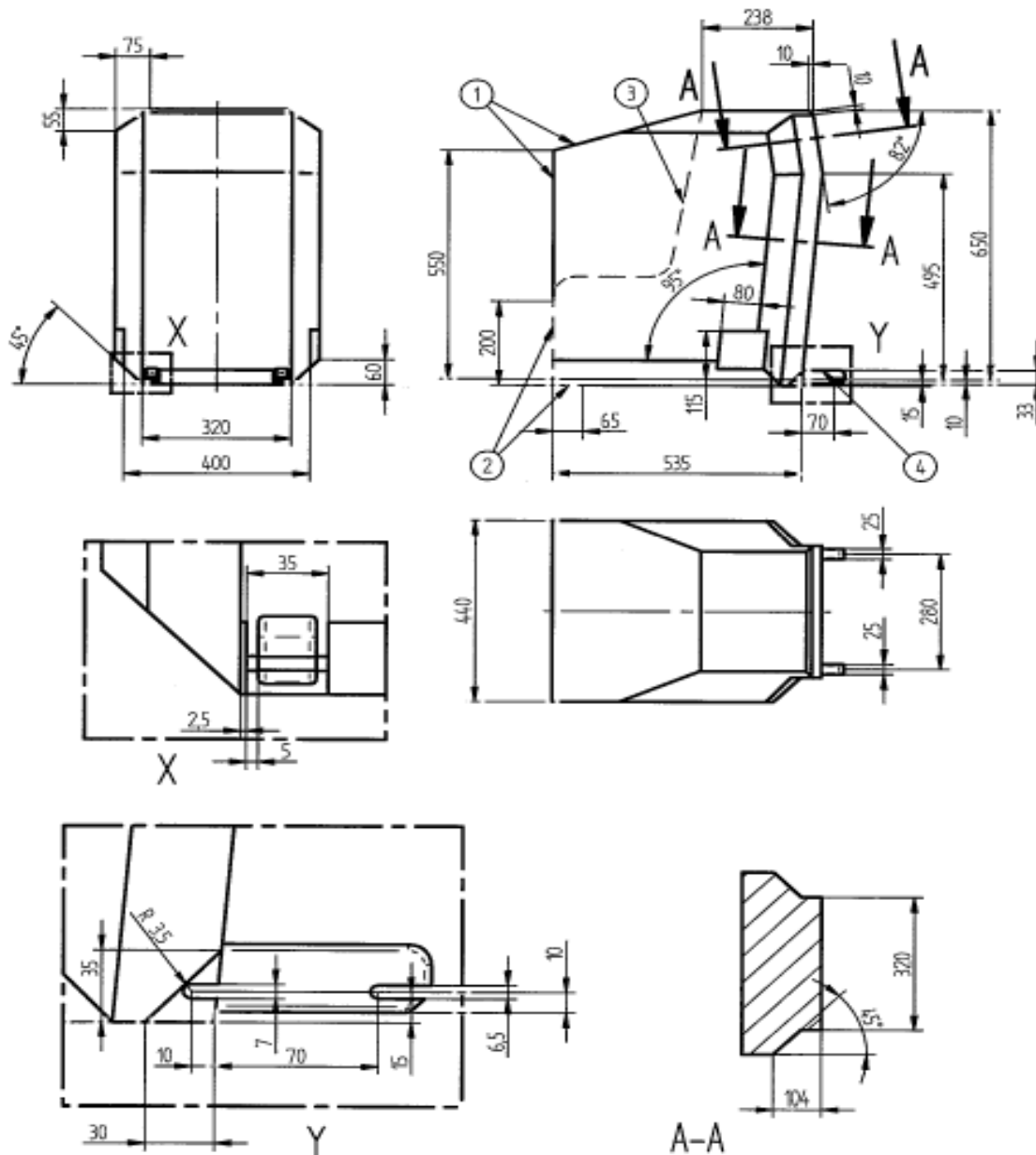

Key:

- 1 Limits in the forward and upwards directions
- 2 Dashed line marks area where a support leg, or similar, of a specific vehicle CRS is allowed to protrude.
- 3 N/A
- 4 Further specifications of the connector area are given in UN Regulation No. 44.

4.4. Full-size rearward facing toddler child restraint system envelope

9. Figure 4

ISO/R3 envelope dimensions for a full-size rearward-facing toddler CRS ISOFIX SIZE CLASS C

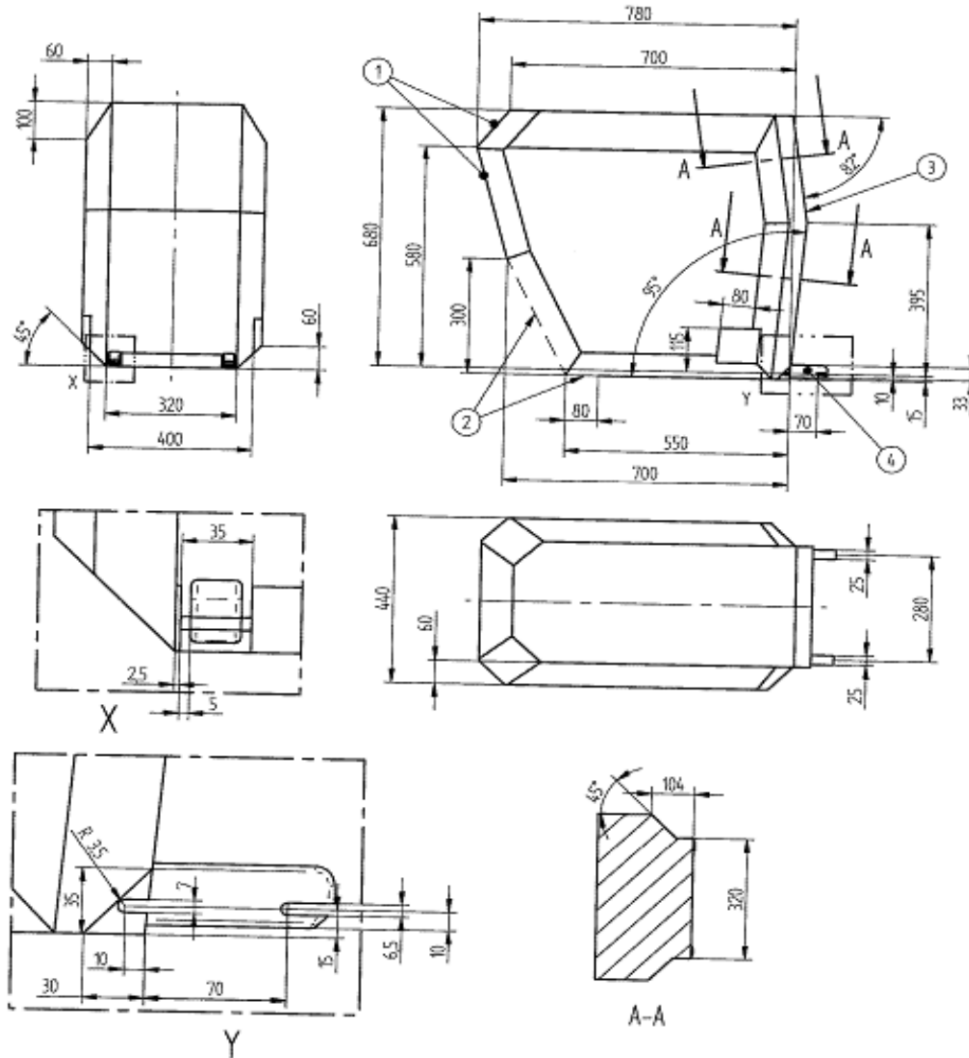

Key:

- 1 Limits in the rearward and upwards directions
- 2 Dashed line marks area where a support leg, or similar, of a specific vehicle CRS is allowed to protrude.
- 3 The backwards limitation (to the right in the figure) is given by the forward-facing envelope in Figure 2
- 4 Further specifications of the connector area are given in UN Regulation No. 44.

4.5. Reduced-size rearward-facing toddler child restraint systems envelope

10. Figure 5

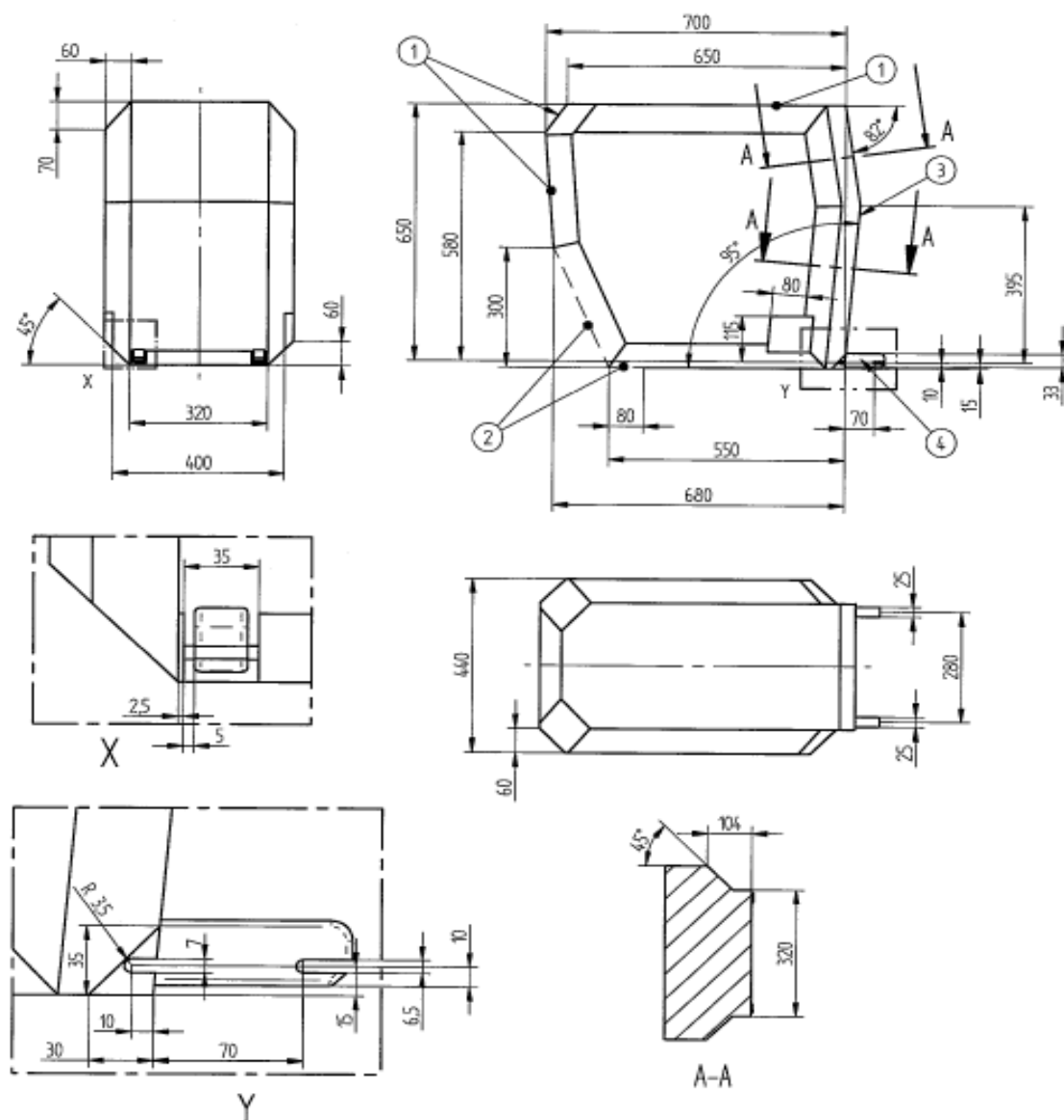
ISO/R2 envelope dimensions for a reduced-size rearward-facing toddler CRS ISOFIX SIZE CLASS D

Key:

- 1 Limits in the rearward and upwards directions
- 2 Dashed line marks area where a support leg, or similar, of a specific vehicle CRS is allowed to protrude.
- 3 The backwards limitation (to the right in the figure) is given by the forward-facing envelope in Figure 2
- 4 Further specifications of the connector area are given in UN Regulation No. 44.

4.6. Rearward facing infant child restraint systems envelope

11. Figure 6
**ISO/R1 envelope dimensions for an infant-size rearward-facing CRS ISOFIX
 SIZE CLASS E**

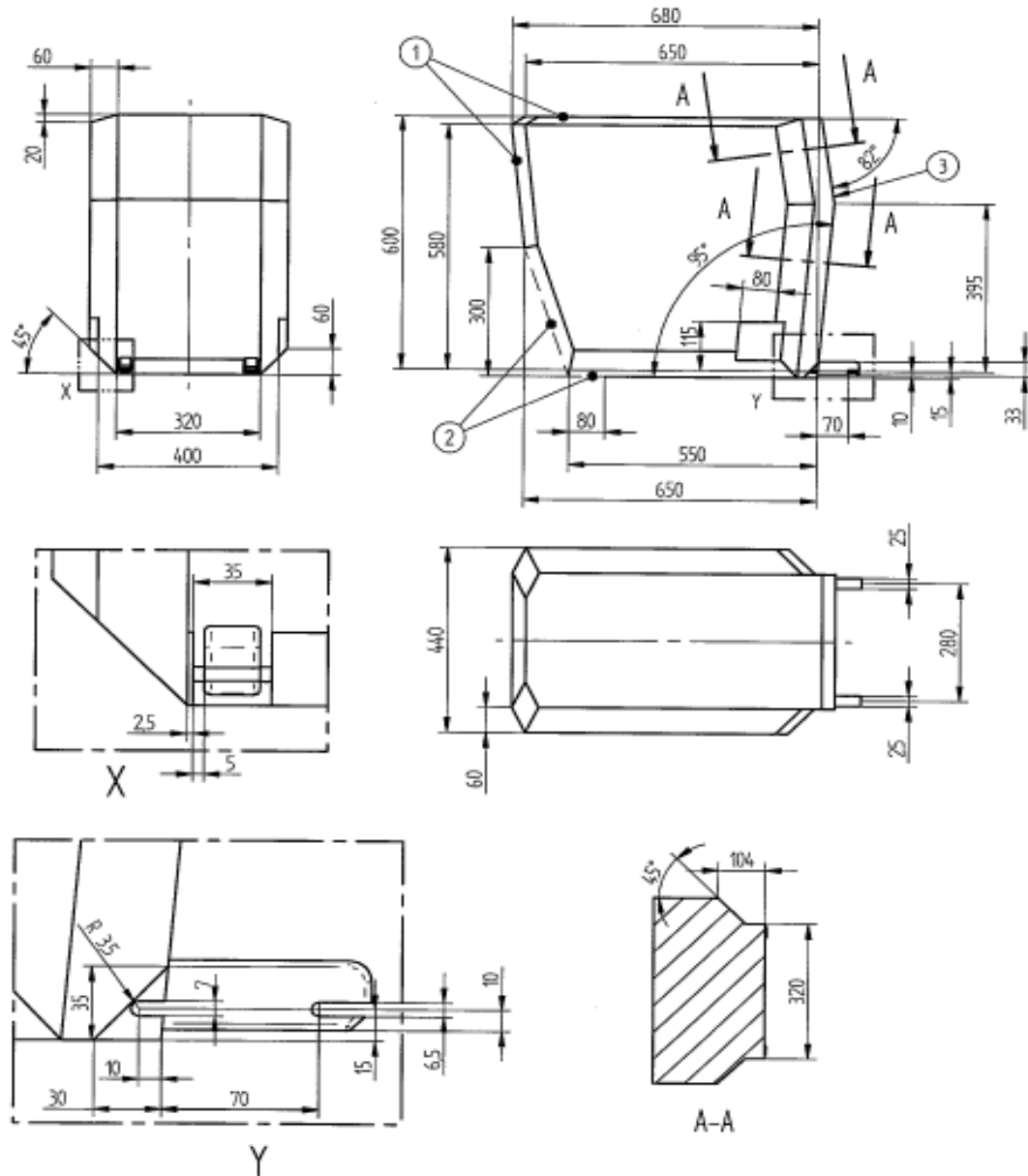

Key:

- 1 Limits in the rearward and upwards directions
- 2 Dashed line marks area where a support leg, or similar, of a specific vehicle CRS is allowed to protrude.
- 3 The backwards limitation (to the right in the figure) is given by the forward-facing envelope in Figure 2
- 4 Further specifications of the connector area are given in UN Regulation No. 44.

4.7. Lateral facing child restraint systems envelope

Figure 7
Reduced-Size Rearward Facing toddler CRS Envelope dimensions for a reduced-size rearward-facing CRS, modified for improved compatibility with the vehicle interior

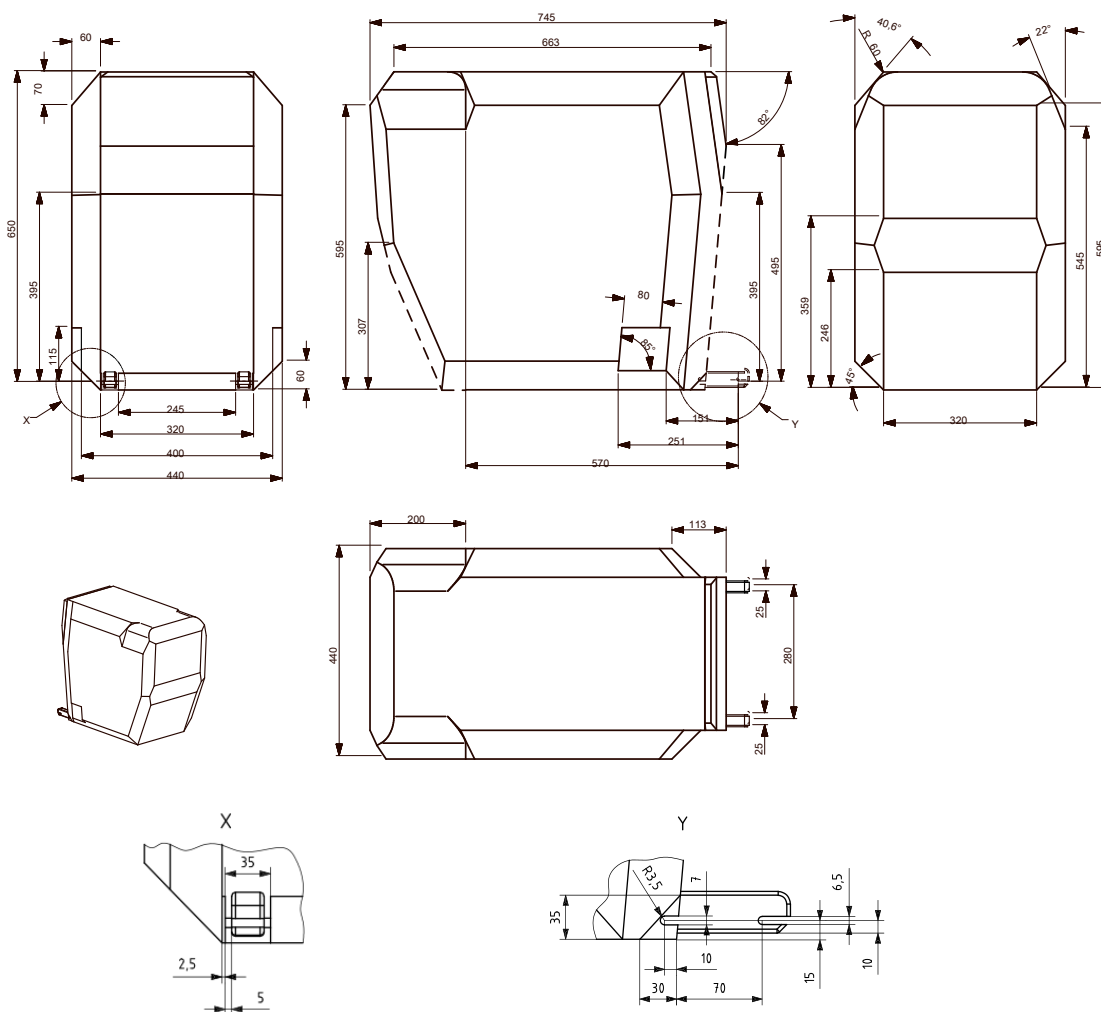

(all dimensions in millimeters)

Key

- 1 Limits in the rearward and upward directions
- 2 Dashed lines mark the area where an anti-rotation device, or similar (e.g. rebound bar), is allowed to protrude
- 3 The backward limitation (to the right in the figure) is given by the forward-facing envelope in Figure 2
12. 4 For further specifications of the connector area, see detail Y and ISO 13216-1:1999, Figures 2 and 3.

Figure 8
Envelope dimensions for lateral facing position CRS - ISO/L1- or symmetrically opposite - ISO/L2 (figure shown)

Note: The envelope for a left lateral-facing infant CRS (ISO/L1) has dimensions symmetric to ISO/L2 with regard to its intermediate longitudinal plan.

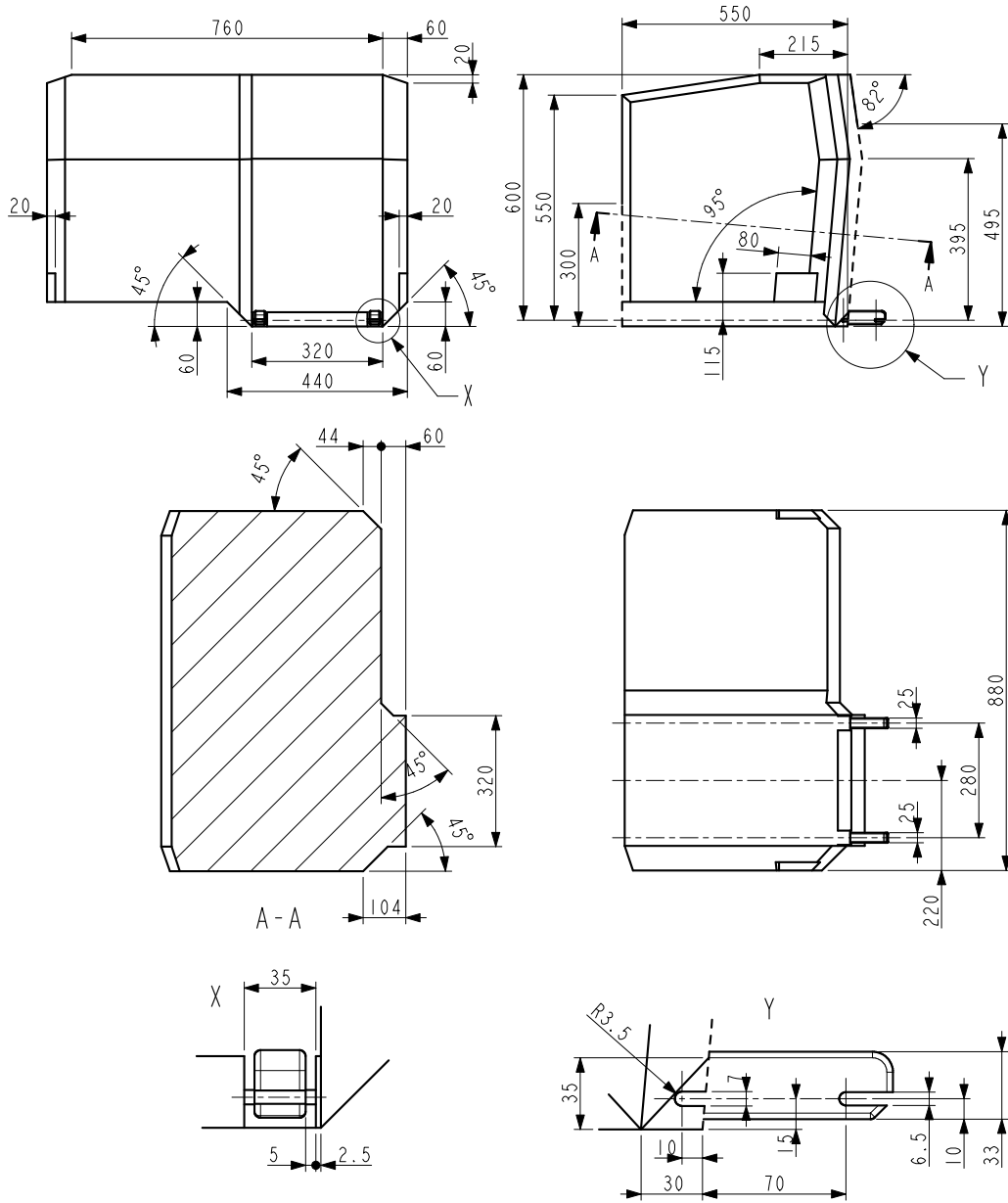

(all dimensions in millimetres)

Key

- 1 Limits in the rearward and upward directions
- 2 Dashed lines mark the area where an anti-rotation device, or similar (e.g. rebound bar), is allowed to protrude.

13. Figure 9
Side view of the i-Size support leg installation assessment volume for assessing compatibility of the i-Size seating positions with support legs of i-Size child restraint systems

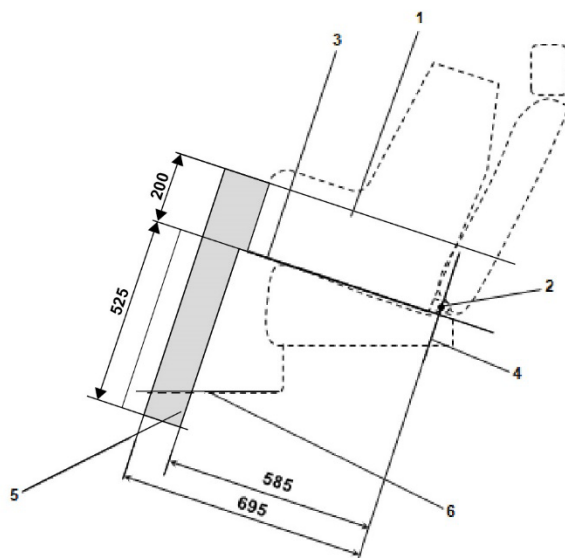

Key:

1. Child Restraint Fixture (CRF).
2. ISOFIX low anchorage bar.
3. Plane formed by the bottom surface of the CRF when installed in the designated seating position.
4. Plane passing through the lower anchorage bar and oriented perpendicular to the median longitudinal plane of the CRF and perpendicular to the plane formed by the bottom surface of the CRF when installed in the designated seating position.
5. i-Size support leg installation assessment volume representing the geometrical boundaries for an i-Size ISOFIX child restraint system support leg.
6. Vehicle floor.

Note: Drawing not to scale.

14. Figure 10
3D view of the i-Size support leg installation assessment volume for assessing compatibility of the i-Size seating positions with support legs of i-Size child restraint systems

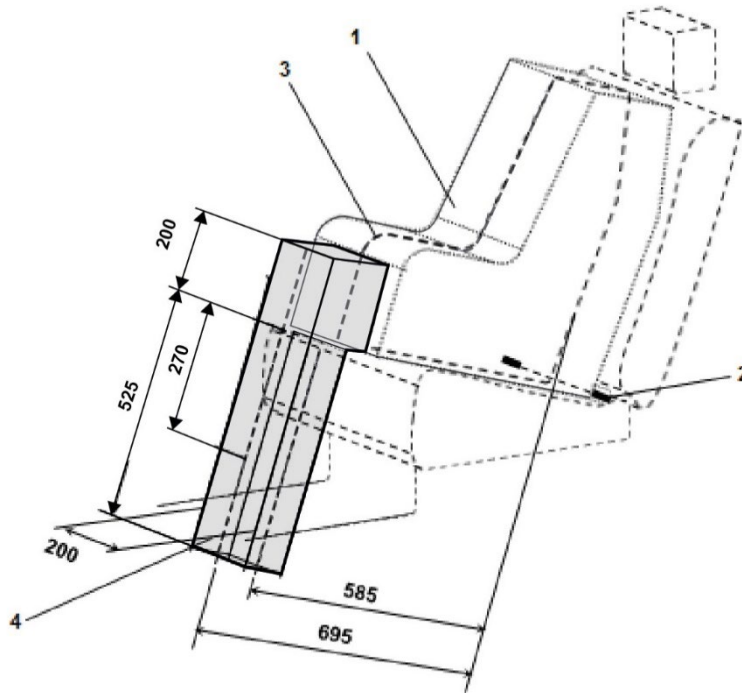

(all dimensions in millimetres)

Key:

1. Child Restraint Fixture (CRF).
2. ISOFIX low anchorages bar.
3. Median longitudinal plane of the CRF.
4. i-Size support leg installation assessment volume.

Note: Drawing not to scale.

Annex 6 – Appendix 3

Example of detailed information e.g. for child restraint system manufacturers

15. Table 1

**Technical Information Specifically for e.g. Child Restraint System Manufacturers
(and as such, translation into national languages is not required)**

Seat position number	Seating position								
	1	2	3	4	5	6	7	8	9
Seating position suitable for universal belted (yes/ no)									
i-Size seating position (yes/ no)									
Seating position suitable for lateral fixture (L1/ L2)									
Largest suitable rearward facing fixture (R1/ R2X/ R2/ R3)									
Largest suitable forward facing fixture (F2X /F2/ F3)									
Largest suitable booster fixture (B2/B3)									

1. Add information for each non i-size seating position compatible with a support leg, as described in this regulation.
2. Add information for each seating position equipped with lower ISOFIX anchorages but without top tether, according to this regulation.
3. Add information if the adult safety belt buckles are located laterally in between both ISOFIX lower anchorages.
4. Add information where any seating position is provided with lower tether anchorages and/or lower tether brackets and/or in case the top tether anchorage of the front seat (if available) may be used as LTA.

Note:

1. Orientation is normal driving direction; columns for seating positions not available in a vehicle can be deleted.
2. The numbering of seating positions shall be made on basis of following definition:

Seat Number	Position in the vehicle
1	Front left
2	Front centre
3	Front right
4	2 nd row left
5	2 nd row centre
6	2 nd row right
7	3 rd row left
8	3 rd row centre

<i>Seat Number</i>	<i>Position in the vehicle</i>
9	3 rd row right

The information about the seat position number can be given by means of a table or by sketches or pictograms.

Annex 6 – Appendix 4

Installation of 10-year manikin

- (a) Adjust the seat to its fully rearward position.
- (b) Adjust the seat height in accordance with the manufacturer's specifications. In the absence of any specification, adjust the seat to the lowest position.
- (c) Adjust the seat back angle to the manufacturer's design position. In the absence of any specification, an angle of 25 degrees from the vertical, or the nearest fixed position of the seat back, should be used.
- (d) Set the shoulder anchorage to the lowest position.
- (e) Set the manikin on the seat ensuring that the pelvis is in contact with the seat back.
- (f) The longitudinal plan passing by the manikin centre line will be on the apparent centre line of the seating position.

Annex 6 – Appendix 5

Provisions concerning the installation of forward-facing booster seat child restraint systems of i-Size and specific categories installed on vehicle seating positions or i-Size seating positions

1. General
 - 1.1. The test procedure and the requirements in this appendix shall be used to determine the suitability of seating positions for the installation of the booster seat fixtures ISO/B2 or ISO/B3, without ISOFIX attachments. Where the vehicle manufacturer has indicated that the vehicle position(s) will accommodate a particular CRF, then it shall be assumed that smaller CRFs of the same orientation will also be accommodated.
 - 1.2. The tests may be carried out in the vehicle or in a representative part of the vehicle. Compliance with this requirement can be proven by a physical test or computer simulation or representative drawings.
2. Test procedure

i-Size positions in the vehicle, defined by the vehicle manufacturer, shall be checked to ensure that the ISO/B2 fixture listed in paragraph 4 of this appendix can be accommodated, at least without ISOFIX connections.

 - 2.1. Adjust the seat to its fully rearward and lowest position.
 - 2.2. Adjust the seat-back angle to the manufacturer's design position. In the absence of any specification, a torso angle of 25 degrees from the vertical, or the nearest fixed position of the seat-back, should be used.
 - 2.3. When checking a CRF, on a rear seat, the vehicle seat located in front of this rear seat may be adjusted longitudinally forward but not further than the mid position between its rearmost and fore most positions. The seat backrest angle may also be adjusted, but not to a more upright angle than corresponding to a torso angle of 15°. If the front seat is adjustable in height, adjust to the manufacturer's specification. In the absence of any specification, adjust the front seat to mid height position, or the nearest position to mid height.
 - 2.4. If necessary, head restraints may be adjusted or removed, if possible.
 - 2.5. Set the shoulder anchorage to the position defined by the vehicle manufacturer.
 - 2.6. Place cotton cloths on the seat-back and cushion, if needed.
 - 2.7. Remove the ISOFIX attachments from the CRF, or retract them to a position fully inside the backseat line (reference line E, Figure 2 or 3).
 - 2.8. Place the fixture (as described in Figure 2 or 3 of this appendix) on the vehicle seat. The top of the fixture may touch the vehicle roof. Compression of the seat cushion is allowed to move the fixture into position.
 - 2.9. Arrange the seat belt through the CRF in approximately the correct position, and then fasten the buckle. Ensure that all webbing slack is removed. The fixture shall be restrained by the vehicle's seat belt.
 - 2.10. Ensure that the fixture is located with its centreline on the apparent centreline of the seating position ± 25 mm with its centreline parallel with the centreline of the vehicle seat. The roll angle α (see Figure 1) shall be within $0^\circ \pm 5^\circ$
 - 2.11. Push rearwards on the centre of the front of the fixture with a force $100 \text{ N} \pm 10 \text{ N}$, applied parallel to the lower surface, and remove the force.

- 2.12. When possible, push vertically downwards on the centre of the upper surface of the fixture with a force of $100\text{ N} \pm 10\text{ N}$, and remove the force.
3. Requirements
- 3.1. It shall be possible to secure the fixture in the seating position using the 3-point seat belt and to buckle up the seat belt.
- 3.2. The roll angle α as shown in Figure 1 shall be equal to or less than 5° .
- 3.3. The base of the fixture shall be in contact with the seat cushion, and the back face of the fixture shall be in contact with the seat back or head restraint. Full contact with the seat is not necessary, "gaps" due to the vehicle seats contours are permitted as shown by the arrows in Figure 1. The booster seat envelope is equipped with an adjustable backrest. Compatibility with the vehicle seating position shall be achieved in at least one position of the backrest range shown in Figure 2 or Figure 3.
- 3.4. Should the above requirements not be met with the adjustments indicated in paragraphs 2.1. to 2.12. above, the seat, seat-back and safety-belt anchorages may be adjusted to an alternative position designated by the manufacturer for normal use at which the above installation procedure shall be repeated and the requirements again verified and met. This alternative position shall be described according to paragraph 1.1. of Annex 6 and in detailed technical information specified in Appendix 3.
4. Booster seat child restraint system fixtures:
- (a) ISO/B2: Booster seat, reduced width 440 mm (Figure 2)
- (b) ISO/B3: booster seat, full width 520 mm (Figure 3)
- The fixtures above shall be constructed with a mass of $7\text{ kg} \pm 1\text{ kg}$ and shall be of suitable durability and stiffness to satisfy the functional requirements.

Figure 1
Positioning in Seat

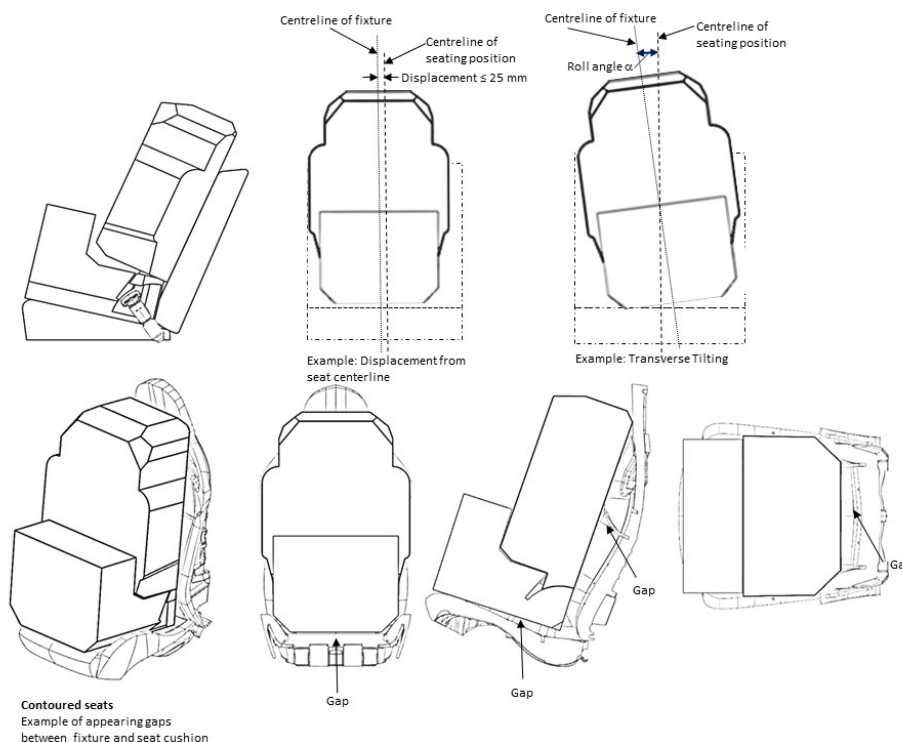
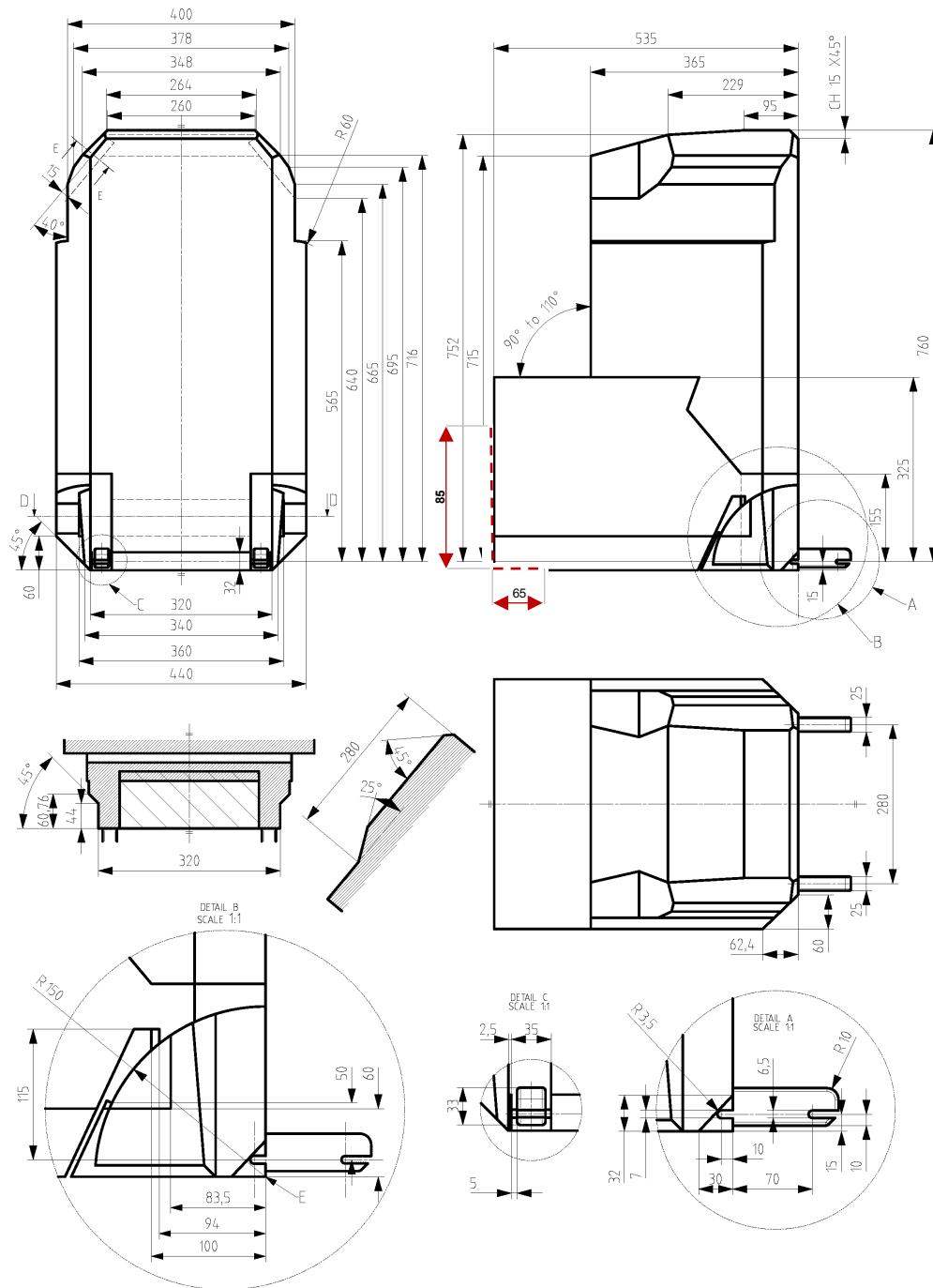

Figure 2
ISO/B2: Envelope dimensions for booster seat, reduced width 440 mm - without ISOFIX, or with connectors removed or stowed within the body of the fixture (behind line E, as defined by detail B)



(all dimensions in millimetres)

Key

1. E is the Reference axle of rotation of the backrest (90° to 110°) and reference line for retraction/stowing of ISOFIX
2. Dashed lines mark the area where an anti-rotation device, or similar is allowed to protrude

Figure 3
ISO/B3 - Envelope dimensions for booster seat, full width 520 mm - without ISOFIX, or with connectors removed or stowed within the body of the fixture (behind line E, as defined by detail B)

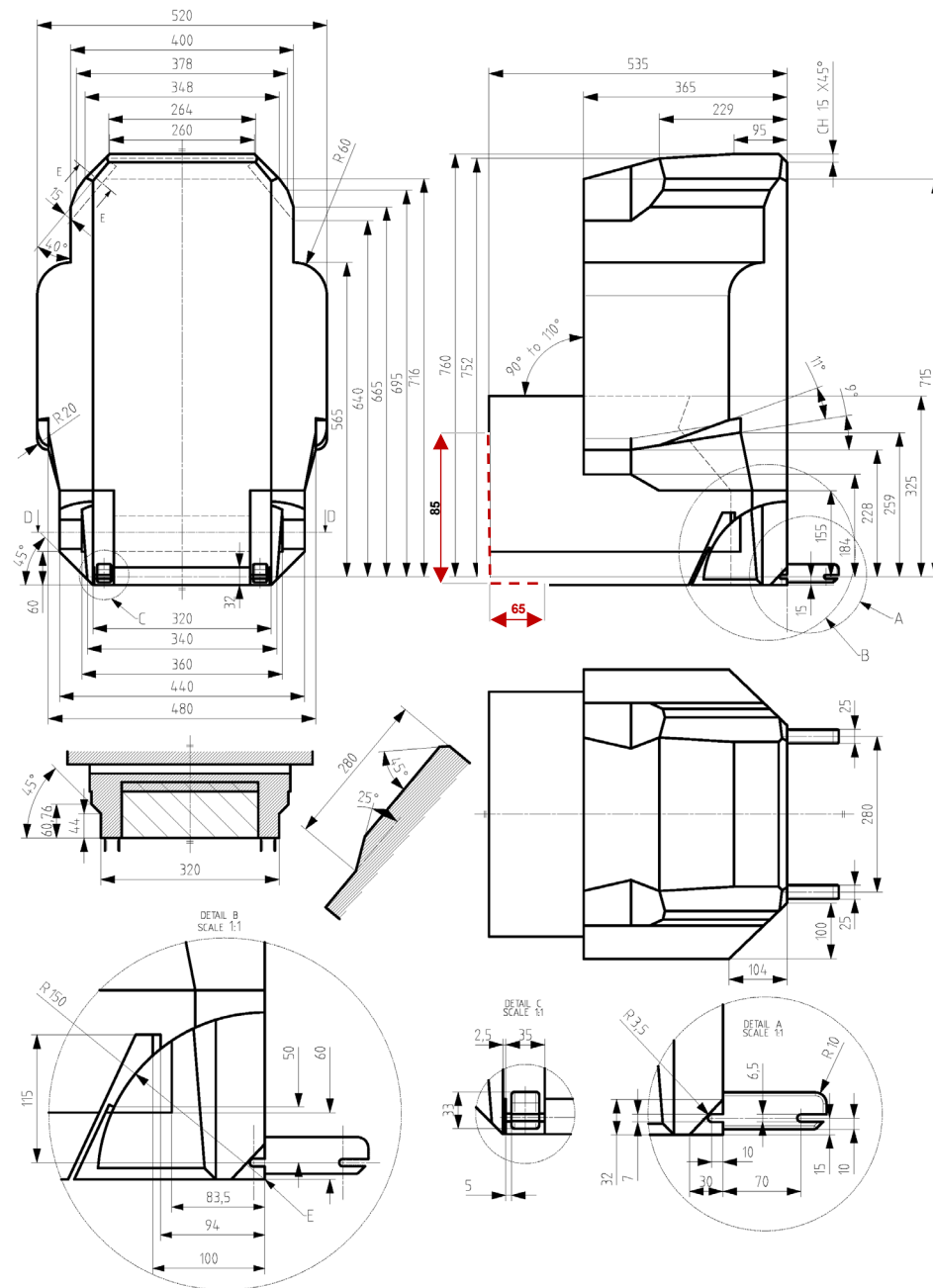

(all dimensions in millimetres)

Key

1. E is the reference axle of rotation of the backrest (90° to 110°) and reference line for retraction/stowing of ISOFIX
2. Dashed lines mark the area where an anti-rotation device, or similar is allowed to protrude"