

---

## **Proposal for Supplement 4 to the 03 and Supplement 1 the 04 Series of Amendments of UN Regulation No. 100 (Electric power-train vehicles)**

### **Submitted by the experts from the International Association of the Body and Trailer Building Industry (CLCCR)**

The text reproduced below was prepared by the experts from France, the Netherlands and CLCCR. The text is based on informal document GRSP-72-27 as proposed by France and on working document GRSP/2022/14 as proposed by CLCCR. The modifications to the current text of the regulation are marked in bold black characters and strikethrough for deleted characters.

## **I. Proposal**

*Paragraphs 1.1. and 1.2., amend to read:*

### **"1. Scope**

- 1.1. Part I: Safety requirements with respect to the electric power train of road vehicles of categories M, ~~and N~~ **and O**<sup>1</sup>, with a maximum design speed exceeding 25 km/h, equipped with electric power train, excluding vehicles permanently connected to the grid.

**However, for vehicles of category O, for batteries whose primary use is to supply power for other vehicle auxiliaries' systems with voltage of the live parts above 60 V DC or equal or above 30 V AC (rms), the requirements as defined for a REESS in part I of this regulation shall apply.**

Part I of this regulation does not cover;

- (a) Post-crash safety requirements of road vehicles.
- (b) High voltage components and systems which are not galvanically connected to the high voltage bus of the electric power train.
- (c) **High voltage electricity connection between the towing vehicle and the trailer(s)**

- 1.2. Part II: Safety requirements with respect to the Rechargeable Electrical Energy Storage System (REESS), of road vehicles of categories M, ~~and N~~ **and O** equipped with electric power train, excluding vehicles permanently connected to the grid.

---

<sup>1</sup> As defined in the Consolidated Resolution on the Construction of Vehicles (R.E.3.), document ECE/TRANS/WP.29/78/Rev.6, para. 2. – <https://unece.org/transport/standards/transport/vehicle-regulations-wp29/resolutions>

Part II of this Regulation does not apply to a battery whose primary use is to supply power for starting the engine and/or lighting and/or other vehicle auxiliaries' systems.

**However, for vehicles of category O, for batteries whose primary use is to supply power for other vehicle auxiliaries' systems with voltage of the live parts above 60 V DC or equal or above 30 V AC (rms), the requirements as defined for a REESS in part II of this regulation shall apply."**

*Paragraph 2.1., amend to read:*

## **"2. Definitions**

For the purpose of this Regulation the following definitions apply:

- 2.1. **"Active driving possible mode"** means the vehicle mode when application of pressure to the accelerator pedal (or activation of an equivalent control) or release of the brake system will cause the electric power train to move the vehicle **or in case of a vehicle of category O, the vehicle mode when coupled with a towing vehicle in active driving possible mode."**

*Insert new Paragraph 2.x. and renumber the other paragraphs (Number x is to be defined based on last amendment of UN R100):*

- 2.x. **"Trailer load compartment"** means the compartment of the trailer described by the bodywork. The trailer load compartment is contained by the floor of the loading area and the inner surface of the bodywork as well as inside the storage equipment (e.g. pallet box etc.), if any."

*Insert new Paragraph 2.x. and renumber the other paragraphs (Number x is to be defined based on last amendment of UN R100):*

- 2.x. **"Auxiliary devices" (or "auxiliaries' systems")** means energy consuming, converting, storing or supplying non-peripheral devices or systems which are installed in the vehicle for purposes other than the propulsion of the vehicle and are therefore not considered to be part of the powertrain."

*Paragraph 5.1.1., amend to read:*

## **"5. Part I: Requirements of a vehicle with regard to specific requirements for the electric power train**

- 5.1.1. Protection against direct contact
- Live parts shall comply with paragraphs 5.1.1.1. and 5.1.1.2. for protection against direct contact. Electrical protection barriers, enclosures, solid insulators and connectors shall not be able to be opened, separated, disassembled or removed without the use of tools or, for vehicles of categories N<sub>2</sub>, N<sub>3</sub>, M<sub>2</sub>, ~~and~~ M<sub>3</sub>, **O<sub>3</sub> and O<sub>4</sub>**, an operator controlled activation/deactivation device or equivalent.

However, connectors (including the vehicle inlet) are allowed to be separated without the use of tools, if they meet one or more of the following requirements:

- (a) They comply with paragraphs 5.1.1.1. and 5.1.1.2. when separated, or
- (b) They are provided with a locking mechanism (at least two distinct actions are needed to separate the connector from its mating component). Additionally, other components, not being part of the connector, shall be removable only with the use of tools or, for vehicles of categories N<sub>2</sub>, N<sub>3</sub>, M<sub>2</sub>, ~~and~~ M<sub>3</sub>, **O<sub>3</sub> and O<sub>4</sub>**, an operator controlled activation/deactivation device or equivalent in order to be able to separate the connector, or
- (c) The voltage of the live parts becomes equal or below 60 V DC or equal or below 30 V AC (rms) within 1 s after the connector is separated.

For vehicles of categories N<sub>2</sub>, N<sub>3</sub>, M<sub>2</sub>, ~~and~~ M<sub>3</sub>, **O<sub>3</sub> and O<sub>4</sub>**, conductive connection devices not energized except during charging of the REESS are exempted from this requirement if located on the roof of the vehicle out of reach for a person standing outside of the vehicle and, for vehicles of category M<sub>2</sub> and M<sub>3</sub>, the minimum wrap around distance from the instep of the vehicle to the roof mounted charging devices is 3 m. In case of multiple steps due to an elevated floor inside the vehicle, the wrap around distance is measured from the bottom most step at entry, as illustrated in Figure 1."

Figure 1  
**Schematic to Measure Wrap-Around Distance**

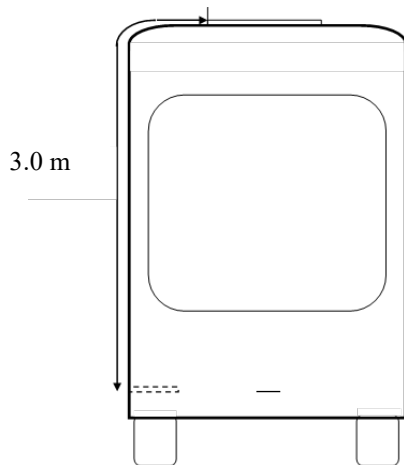

*Paragraph 5.1.1.1.*, amend to read:

- “5.1.1.1. For high voltage live parts inside the passenger compartment, or luggage compartment, **or trailer load compartment**, the protection degree IPXXD shall be provided.”

*Paragraph 5.1.1.2., amend to read:*

- "5.1.1.2. For high voltage live parts in areas other than the passenger compartment, or luggage compartment **or trailer load compartment**, the protection degree IPXXB shall be provided."

*Paragraph 5.1.1.3., amend to read:*

- "5.1.1.3. Service disconnect

For a high voltage service disconnect which can be opened, disassembled or removed without tools, or for vehicles of categories N<sub>2</sub>, N<sub>3</sub>, M<sub>2</sub>, ~~and~~ M<sub>3</sub>, **O<sub>3</sub> and O<sub>4</sub>**, an operator controlled activation/deactivation device or equivalent, protection degree IPXXB shall be satisfied when it is opened, disassembled or removed."

*Paragraph 5.1.1.4.2., amend to read:*

- "5.1.1.4.2. The symbol shall also be visible on enclosures and electrical protection barriers, which, when removed, expose live parts of high voltage circuits. This provision is optional to any connector for high voltage buses. This provision shall not apply to any of the following cases:
- (a) Where electrical protection barriers or enclosures cannot be physically accessed, opened, or removed; unless other vehicle components are removed with the use of tools;
  - (b) Where electrical protection barriers or enclosures are located underneath the vehicle floor.
  - (c) Electrical protection barriers or enclosures of conductive connection device for vehicles of categories N<sub>2</sub>, N<sub>3</sub>, M<sub>2</sub>, ~~and~~ M<sub>3</sub>, **O<sub>3</sub> and O<sub>4</sub>** which satisfies the conditions prescribed in paragraph 5.1.1."

*Paragraph 5.1.2.3., amend to read:*

- "5.1.2.3. In the case of ~~motor~~ vehicles which are intended to be connected to the grounded external electric power supply through the conductive connection between vehicle inlet and vehicle connector, a device to enable the galvanical connection of the electrical chassis to the earth ground for the external electric power supply shall be provided.

The device should enable connection to the earth ground before exterior voltage is applied to the vehicle and retain the connection until after the exterior voltage is removed from the vehicle.

Compliance to this requirement may be demonstrated either by using the connector specified by the vehicle manufacturer, by visual inspection or drawings.

The above requirements are only applicable for vehicles when charging from a stationary charging point, with a charging cable of finite length, through a vehicle coupler comprising a vehicle connector and a vehicle inlet."

*Paragraphs 5.2.3. and 5.2.4. amend to read:*

"5.2.3.           Warning in the event of failure in REESS

The vehicle shall provide a warning to the driver when the vehicle is in active driving possible mode in the event specified in paragraphs 6.13. to 6.15.

In case of optical warning, the tell-tale shall, when illuminated, be sufficiently bright to be visible to the driver under both daylight and night-time driving conditions, when the driver has adapted to the ambient roadway light conditions.

This tell-tale shall be activated as a check of lamp function either when the propulsion system is turned to the "On" position, or when the propulsion system is in a position between "On" and "Start" that is designated by the manufacturer as a check position. This requirement does not apply to the tell-tale or text shown in a common space.

**Notwithstanding the provisions above in case of vehicles of category O, the trailer shall provide an optical and/or audible warning to the driver of the towing vehicle in the event specified in paragraphs 6.13. to 6.15.**

**In case of vehicles of category O<sub>3</sub> and O<sub>4</sub>, the trailer may provide to the towing vehicle a signal to address an optical warning according to this paragraph and/or an audible warning (e.g. transmission via CAN-Bus according to ISO 11992-2) in the event specified in paragraphs 6.13. to 6.15."**

5.2.4.           Warning in the event of low energy content of REESS.

For pure electric vehicles (vehicles equipped with a powertrain containing exclusively electric machines as propulsion energy converters and exclusively rechargeable electric energy storage systems as propulsion energy storage systems), a warning to the driver in the event of low REESS state of charge shall be provided. Based on engineering judgment, the manufacturer shall determine the necessary level of REESS energy remaining, when the driver warning is first provided.

In case of optical warning, the tell-tale shall, when illuminated, be sufficiently bright to be visible to the driver under both daylight and night-time driving conditions, when the driver has adapted to the ambient roadway light conditions.

**This warning signal is not required for vehicles of category O."**

*Paragraphs 5.3.1. and 5.3.2. amend to read:*

"5.3.           Preventing accidental or unintended vehicle movement

5.3.1.           At least a momentary indication shall be given to the driver each time when the vehicle is first placed in "active driving possible mode" after manual activation of the propulsion system.

However, this provision is optional under conditions where an internal combustion engine provides directly or indirectly the vehicle's propulsion power upon start up **and for vehicles of category O.**

**To ensure that the vehicle of category O does not activate its driving mode independently, it shall be ensured that its propulsion system is only activated if the trailer is coupled to a towing vehicle and if a signal or command or action is transmitted to the trailer propulsion system.**

- 5.3.2. When leaving the vehicle, the driver shall be informed by a signal (e.g. optical or audible signal) if the vehicle is still in the active driving possible mode. Moreover, in case of vehicles of category M<sub>2</sub> and M<sub>3</sub> with a capacity of more than 22 passengers in addition to the driver, this signal shall already be given when the drivers leave their seat.

However, this provision is optional under conditions where an internal combustion engine provides, directly or indirectly, the vehicle's propulsion power while leaving the vehicle or driver seat **and for vehicles of category O."**

*Paragraphs 5.3.3. and new figure 3, amend to read :*

- "5.3.3. If the REESS can be externally charged, vehicle movement by its own propulsion system shall be impossible as long as the vehicle connector is physically connected to the vehicle inlet.

This requirement shall be demonstrated by using the vehicle connector specified by the vehicle manufacturer.

**In case of vehicles of category O a trailer parking brake shall be automatically activated as long as the trailer connector is physically connected to the trailer inlet.**

The above requirements are only applicable for vehicles when charging from a stationary charging point, with a charging cable of finite length, through a vehicle coupler comprising a vehicle connector and a vehicle inlet."

*Annex 9C Mechanical shock Paragraphs 3.2. amend to read:*

- "3.2. Test procedure

The Tested-Device shall be decelerated or accelerated in compliance with the acceleration corridors which are specified in Tables 1 to 3. The manufacturer shall decide whether the tests shall be conducted in either the positive or negative direction or both.

For each of the test pulses specified, a separate Tested-Device may be used.

The test pulse shall be within the minimum and maximum value as specified in Tables 1 to 3. A higher shock level and /or longer duration as described in the maximum value in Tables 1 to 3 can be applied to the Tested-Device if recommended by the manufacturer.

The test shall end with an observation period of 1 hour at the ambient temperature conditions of the test environment.

Figure 1  
 Generic description of test pulses

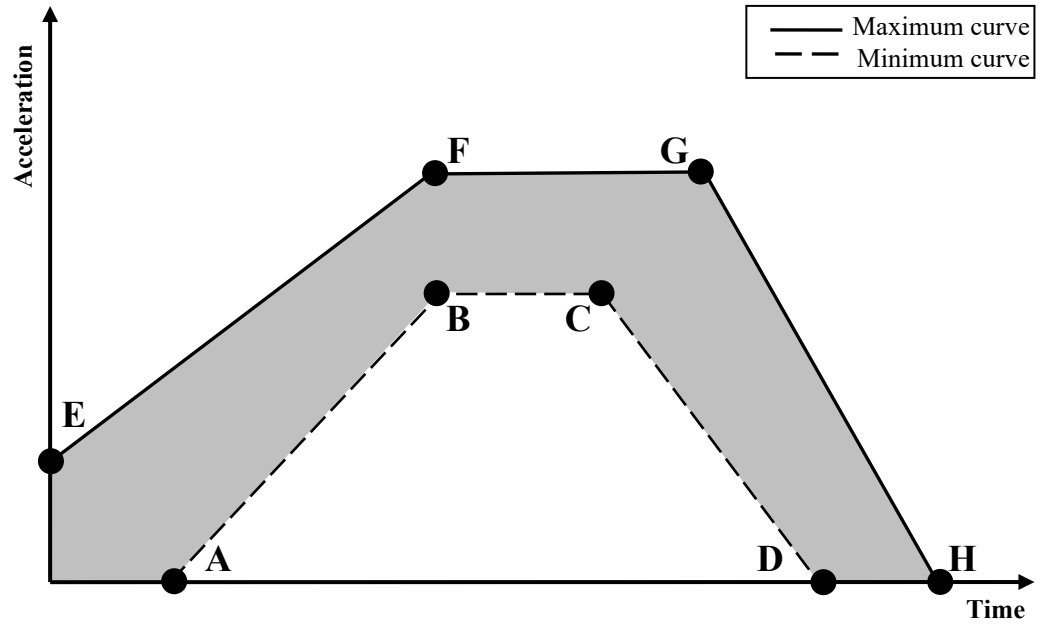

Table 1 for M<sub>1</sub>, and N<sub>1</sub>, O<sub>1</sub> and O<sub>2</sub> vehicles<sup>1</sup>:

Point	Time (ms)	Acceleration (g)	
		Longitudinal	Transverse
A	20	0	0
B	50	20	8
C	65	20	8
D	100	0	0
E	0	10	4.5
F	50	28	15
G	80	28	15
H	120	0	0

Table 2 for M<sub>2</sub> and N<sub>2</sub> vehicles:

Point	Time (ms)	Acceleration (g)	
		Longitudinal	Transverse
A	20	0	0
B	50	10	5

C	65	10	5
D	100	0	0
E	0	5	2.5
F	50	17	10
G	80	17	10
H	120	0	0

Table 3 for M<sub>3</sub>, and N<sub>3</sub>, O<sub>3</sub>, O<sub>4</sub> vehicles:

Point	Time (ms)	Acceleration (g)	
		Longitudinal	Transverse
A	20	0	0
B	50	6,6	5
C	65	6,6	5
D	100	0	0
E	0	4	2.5
F	50	12	10
G	80	12	10
H	120	0	0

The test shall end with an observation period of 1 hour at the ambient temperature conditions of the test environment."

Add new footnote 1 in Annex 9C Mechanical shock Paragraphs 3.2. table 1:

- 1** For vehicles of category O<sub>1</sub> and O<sub>2</sub> at the request of the manufacturer the pulses defined in table 2 of Annex 9C paragraph 3.2 may be used if the maximum design speed of these vehicles of category O<sub>1</sub> and O<sub>2</sub> is limited to 100 km/h.

## II. Justification

### General

To tackle climate change, it is needed to significantly reduce CO<sub>2</sub> emissions induced by the transport sector worldwide. The transport sector is an important CO<sub>2</sub> emitter after the energy sector and other industry branches. Therefore, stringent goals for heavy duty vehicles are defined to limit the CO<sub>2</sub> emissions. These ambitious goals



will have a major influence on future design of trucks and trailers on roads and it will significantly change the type of propulsion for such vehicle combinations. It might be interesting for a closer look on the potential of trailers to contribute to the overall CO2 reduction of a vehicle combination. The trailer or semitrailer itself does not emit CO2 in standstill or driving modes but contribute to the overall CO2 balance of the vehicle combination. CO2 values may be assigned to the trailer due to its rolling resistance, its kerb weight and finally the air drag. Therefore, it is logically to think about measures/technologies for a reduction of these emissions. Based on this development trailer manufacturers are urged to contribute to CO2 reduction by improved trailer design and new technologies now.

One of these features is a driven axle in a trailer/semi-trailer (e.g. with propulsion and/or recuperation system). Driven axles in trailers have the potential to support the motor vehicle (e.g. the tractor) during start-stop manoeuvres, during accelerating/braking and during transport of heavy loads under ambitious conditions (uphill/downhill) or may convert the kinetic energy of an axle to supply electric systems (e.g. cooling units for reefer). This leads to lower fuel consumption of the motor vehicle respectively cooling units (ergo lower CO2 emissions) and higher agility of the whole vehicle combination. The type of drivetrain may be electrical. The drive train on the trailer/semi-trailer will be controlled to safely follow the towing vehicle. The propelling capacity of any trailer/semi-trailer in a vehicle combination shall be controlled within the vehicle combination in such a way that the longitudinal/lateral stability of the combination is not negatively influenced. The drive train of the trailer/semi-trailer can operate in the full speed range of the vehicle combination and is not limited to low-speed applications.

Heavy trailers (category O3 and O4) are predestined to be propelled by an electric engine to reduce the overall CO2 emission of the tractor/lorry. But also propelled light trailers (category O2) have a huge effect on vehicle dynamics. The use of a trailer (e.g. caravan) results in a huge reduction of the range due to the limited battery capacity of a car. This may lead to low acceptance of battery electric cars in a growing market of caravan users. But especially an electric propulsion in a trailer of category O2 (e.g. caravan) would allow the use of this trailer in a combination with a battery electric vehicle. The e-trailer would be able to guarantee the normal range of the battery electric car in combination with the trailer without any further emissions.

With respect to potential application of electrical energy storage or electric power train in category O vehicles, there might be several possibilities (see following table). This **proposal is focusing on use cases A and E and F**. The uses cases B and C are currently not considered as long the energy transfer between trailer and towing vehicle is not standardized. Use case D describes the possibility for providing energy for equipment without recuperation via external charging. Use case D seems to be possible today without a certification based on UN R100 and is therefore also not considered in this proposal.

<i>Use-case</i>	<i>Energy storage</i>	<i>External charging</i>	<i>Energy Recuperation</i>	<i>Propulsion assist (traction motor)</i>	<i>Energy supply to towing vehicle</i>	<i>Energy supply to equipment (e.g. fridge,)</i>
<b>A</b>	<b>Yes</b>	<b>No</b>	<b>Yes</b>	<b>Yes</b>	<b>No</b>	<b>Yes/No</b>
<b>B</b>	Yes	Yes	Yes	Yes	Yes	Yes/No
<b>C</b>	Yes	Yes	No	No	Yes	Yes/No
<b>D</b>	Yes	Yes	No	No	No	Yes/No
<b>E</b>	<b>Yes</b>	<b>Yes</b>	<b>Yes</b>	<b>Yes</b>	<b>No</b>	<b>Yes/No</b>
<b>F</b>	<b>Yes</b>	<b>Yes</b>	<b>Yes</b>	<b>No</b>	<b>No</b>	<b>Yes/No</b>

**Paragraphs 1.1. and 1.2.**

Vehicles equipped with a propulsion system to support the movement of the towing vehicle are intended to use high voltage components including traction batteries (REESS). Therefore, the scope should be amended by vehicles of category O. Vehicle combinations with a high voltage electricity connection between a towing vehicle and a trailer are currently out of scope.

Further developments of auxiliary units on trailers focus on more efficiency as well as the replacement of current diesel combustion engines by electric solutions (e.g. new full electric cooling machines). It is expected that for

these devices high voltage components and systems may be used. Batteries of such systems which are not connected to the powertrain should be tested according to Part I/II of this regulation.

**Paragraph 2.1.**

The status of the "Active driving possible mode" should be amended by the trailer, which makes clear that the trailers propulsion supports the movement of the towing vehicle.

**Paragraph 2.x**

The wording "trailer load compartment" and "vehicle auxiliaries' systems " are to be defined according to existing definitions in other regulations (i.e. (EU) 2017/1151 (WLTP)).

**Paragraph 5.1.1.**

The requirements for the Protection against direct contact have to be considered by vehicles of category O. Nevertheless vehicles of category O3 and O4 are to be compared in size and use with vehicles in category N2, N3. Therefore O3 and O4 should comply with the requirements for N2, N3.

**Paragraph 5.1.1.1.**

The IPXXD test should be mandatory for high voltage life parts inside the load compartment of the trailer (if any).

**Paragraph 5.1.1.2.**

The IPXXB test should be mandatory for high voltage life parts outside the load compartment of a trailer.

**Paragraph 5.1.1.3.**

The requirements for the Protection against direct contact have to be considered by vehicles of category O. Nevertheless vehicles of category O3 and O4 are to be compared in size and use with vehicles in category N2, N3. Therefore O3 and O4 should comply with the requirements for N2, N3.

**Paragraph 5.1.1.4.2.**

The requirements for the Protection against direct contact have to be considered by vehicles of category O. Nevertheless vehicles of category O3 and O4 are to be compared in size and use with vehicles in category N2, N3. Therefore O3 and O4 should comply with the requirements for N2, N3.

**Paragraph 5.1.3.2.**

The word "motor" is mis-leading in cases of vehicles of category O. This word may be deleted.

**Paragraphs 5.2.3.**

In case of a event of failure in REESS of the trailer the consequences are different from the consequences of a failure of REESS in the motor vehicle. The trailer is per definition a towed vehicle and driving dynamics of the driven trailer doesn't harm the driving of the vehicle combination. Therefore, it is recommended that the trailer is able to provide a signal to the towing vehicle and/or the trailer will give a direct warning.

**Paragraph 5.2.4.**

Low battery content in the trailers leads to an automatic stop of any support functionalities for the forward movement. This means the trailer operates then as a normal trailer without propulsion. Therefore a warning is not necessary.

**Paragraphs 5.3.1. and 5.3.2.**

The preventing of an accidental or unintended vehicle movement of a trailer is essential to guarantee the safe driving. Therefore it must be ensured that the trailer propulsion is controlled by the driving behaviour of the towing vehicle. This means that a signal, command, or action (i.e. electrical control, force-sensitive coupling devices that controls the trailer propulsion, sensors etc) is needed to control the trailer. This signal/command may be transmitted via the CAN bus when available or the signal is induced by on dynamic action of the tractor/trailer combination. This signal/command may be generated in the trailer (e.g. in the coupling device or another trailer component) and/or in the towing vehicle (e.g. CAN bus signal).

### **Paragraph 5.3.3.**

In cases the trailer REESS is charged externally the trailer shall activate its parking brake.

### **Annex 9C Mechanical shock Paragraphs 3.2. table 1, 2 and 3**

The resistance against mechanical shock is focusing on pulses of crash tests or similar performance tests of vehicles of category N1, N2, N3, M1, M2 and M3. Trailers are normally not in the scope of crash test regulations due to missing passengers. Therefore, it is recommended to define the performance pulses for trailers in relation to the category of the trailer and its real use-case.

Based on that:

REESS on O1/O2 may be tested with the pulse as defined for M1/N1 (Table 1), because they are the most common towing vehicles. Nevertheless, with few exceptions, the speed limits worldwide are lower for the combination of towing vehicle and trailer than those for the M1/N1 vehicles alone. Furthermore, the actual deceleration of a REESS into a trailer is lower than on a motorized vehicle because it is somehow mitigated, in the event of a crash, by the presence of the towing vehicle itself. Therefore, an option should be given to the manufacturers of O1/O2 to test their REESS according to the specifications provided for M2/N2 (Table 2), if their design speed is limited to 100 km/h.

REESS for O3/O4 may be tested with a pulse related to requirements for N3/M3, again because they are their most common towing vehicles.

## **Copyright notice**

Copyright 16<sup>th</sup> of April 2024, CLCCR, all rights reserved.

For reproduction permission and all other issues, please contact [info@clccr.eu](mailto:info@clccr.eu)