



# Economic and Social Council

Distr.: General  
1 September 2023

Original: English

---

## Economic Commission for Europe

Inland Transport Committee

World Forum for Harmonization of Vehicle Regulations

191st session

Geneva, 14–16 November 2023

Item 4.13.2 of the provisional agenda

**1958 Agreement:**

**Consideration of draft amendments to existing**

**UN Regulations submitted by GRSP**

### **Proposal as a new UN Regulation Concerning the Approval of Child Restraint Systems for Safer Transport of Children in Buses**

**Submitted by the Working Party on Passive Safety \***

The text reproduced below was adopted by the Working Party on Passive Safety (GRSP) at its seventy-third session (ECE/TRANS/WP.29/GRSP/73 para. 49). It is based on ECE/TRANS/WP.29/GRSP/2023/2, as amended by GRSP-73-04-Rev.1. It is submitted to the World Forum for Harmonization of Vehicle Regulations (WP.29) and to the Administrative Committee (AC.1) for consideration at their November 2023 sessions.

---

\* In accordance with the programme of work of the Inland Transport Committee for 2023 as outlined in proposed programme budget for 2023 (A/77/6 (Sect. 20), table 20.6), the World Forum will develop, harmonize and update UN Regulations in order to enhance the performance of vehicles. The present document is submitted in conformity with that mandate.



## "UN Regulation No. XXX

# Uniform Provisions Concerning the Approval of Child Restraint Systems for Safer Transport of Children in Buses and Coaches

## Contents

Page\*\*

### Regulation

1.	Introduction.....	
2.	Scope .....	
3.	Definitions .....	
4.	Application for Approval .....	
5.	Markings .....	
6.	Approval .....	
7.	General Specifications .....	
8.	Test Requirements .....	
9.	Test reports of Type Approval .....	
10.	Conformity of Production and Routine Tests.....	
11.	Modification and Extension of Approval of a Child Restraint System .....	
12.	Penalties for Non-Conformity of Production .....	
13.	Production Definitively Discontinued .....	
14.	Names and Addresses of Technical Services Responsible for Conducting Approval Tests and of Type Approval Authorities .....	

### Annexes

1	Communication.....	
2	Arrangements of the Approval Mark .....	
3	Internal Measurements .....	
4	Corrosion .....	
5	Overtipping – Load Application Device .....	
6	Dynamic Test .....	
7	Typical Buckle Strength Test Device.....	
8	Description of Conditioning for Adjusters .....	
9	Micro Slip .....	
10	Abrasion .....	
11	Minimum List of Documents Required for Approval.....	

---

\*\* Page numbers will be added at a later stage.

## 1. Introduction

Enhanced Child Restraint System (ECRS) approved according to UN Regulation No. 129 which can be installed in vehicle seats using the belt type and/or ISOFIX attachments can be used.

The Requirements defined in this UN Regulation do not apply to the ECRS approved according to UN Regulation 129.

In case that the vehicle seat is also intended to be used by an adult, the vehicle seats and its safety-belt anchorages shall be approved according to UN Regulation No. 14 and UN Regulation No. 80 or UN Regulation No. 17 if applicable.

## 2. Scope

This Regulation applies to Built-in Child Restraint Systems installed in vehicles of categories M2 and M3 class B and class III with regards to the securing of children from 40 - 150 cm in forward facing and rearward facing vehicle seats.

At the request of the manufacturer, this Regulation may also apply to any Built-in Child Restraint Systems installed in vehicles of categories M2 or M3 of classes I, II and A.<sup>1</sup>

## 3. Definitions

- 3.1. "*Child Restraint System (CRS)*" means a device capable of accommodating a child occupant in a sitting or supine position. It is so designed as to diminish the risk of injury to the wearer, in the event of a collision or of abrupt deceleration of the vehicle, by limiting the mobility of the child's body.
- 3.2. "*Enhanced Child Restraint System (ECRS)*": Is a Child Restraint System approved according to UN Regulation No. 129.
- 3.3. "*Child Restraint System type*" means a Child Restraint System which does not differ in such essential respects as:
- The category in which the restraint is type approved.
- The design, material and construction of the Child Restraint System.
- Convertible or modular Child Restraint Systems shall be considered to not differ in their design, material and construction.
- 3.4. "*Built-in*", is a Child Restraint System made as an integral part of a vehicle seat.
- 3.5. "*Integral*" and "*Non-Integral*"
- 3.5.1. "*Integral*" is a class of Child Restraint System, meaning that the child is restrained only by components separate to the adult safety-belt. (eg. Harness, impact-shield...).
- 3.5.2. "*Non-Integral*" is a class of Child Restraint System, meaning that the retention of the child is achieved by the adult safety-belt.
- 3.6. "*Size*" indicates the stature of the child.
- 3.6.1. "*Size range*" is a range for which the Child Restraint System has been designed and approved.
- 3.6.2. Child Restraint Systems may cover any size range provided that all requirements of this Regulation are fulfilled.

- 3.7. "*Orientation*" indicates a direction in which a Child Restraint System has been approved for use. The following distinctions are made:
- (a) Forward-facing means facing in the normal direction of travel of the vehicle.
  - (b) Rearward-facing means facing in the direction opposite to the normal direction of travel of the vehicle.
  - (c) Lateral-facing means facing perpendicular to the normal direction of travel of the vehicle.
- 3.8. "*Special Needs Restraint*" is a Child Restraint System designed for children who have special needs as a result of either a physical or mental disability; this device may in particular permit additional restraining devices for any part of the child, but it shall contain as a minimum a primary means of restraint which complies with the requirements of this Regulation.
- 3.9. "*Strap*" means a flexible component designed to transmit forces.
- 3.10. "*Lap strap*" means a strap which restrains, directly or not, the child's pelvis.
- 3.11. "*Shoulder strap*" means that part of an CRS belt which restrains the child's upper torso.
- 3.12. "*Crotch strap*" means a strap (or divided straps, where two or more pieces of webbing make it) is so positioned as to pass between the child's thighs it is designed to prevent the child sliding under the lap strap in normal use and prevent the lap strap moving up off the pelvis in an impact.
- 3.13. "*Child-restraining strap*" means a strap which is a constituent part of the CRS belt (harness) and restrains only the body of the child.
- 3.14. "*Buckle*" means a quick release device which enables the child to be held by the restraint or the restraint by the structure of the vehicle seat and can be quickly opened. The buckle may incorporate the adjusting device.
- 3.15. "*Enclosed buckle release button*", a buckle release button such that it shall not be possible to release the buckle using a sphere having a diameter of 40 mm.
- 3.16. "*Non-enclosed buckle release button*", a buckle release button such that it shall be possible to release the buckle using a sphere having a diameter of 40 mm.
- 3.17. "*Adjusting device*" means a device enabling the CRS belt or its attachments to be adjusted to the physique of the wearer. The adjusting device may either be part of the buckle or be a retractor or any other part of the CRS belt.
- 3.18. "*Quick adjuster*" means an adjusting device which can be operated by one hand in one smooth movement.
- 3.19. "*Adjuster mounted directly on Child Restraint System*" means an adjuster for the harness belt which is directly mounted on the Child Restraint System, as opposed to being directly supported by the strap that it is designed to adjust.
- 3.20. "*Energy absorber*" means a device which is designed to dissipate energy independently of or jointly with the strap and forms part of a Child Restraint Systems.
- 3.21. "*Inclined position*" means a special position of the CRS which allows the child to recline.
- 3.22. "*Lying down/supine/prone position*" means a position where at least the child's head and body excluding its limbs are on a horizontal surface when at rest in the CRS.
- 3.23. "*Vehicle seat*" means a structure likely to be anchored to the vehicle structure, including its trim and attachment fittings, intended to be used in a

vehicle, and to seat one or more adult persons. Depending on its orientation, a seat is defined as follows:

- 3.23.1. "*Forward-facing seat*" means a seat which can be used while the vehicle is in motion and which faces towards the front of the vehicle in such a manner that the vertical plane of symmetry of the seat forms an angle of less than  $+10^\circ$  or  $10^\circ$  with the vertical plane of symmetry of the vehicle.
- 3.23.2. "*Rearward-facing seat*" means a seat which can be used while the vehicle is in motion and which faces towards the rear of the vehicle in such a manner that the vertical plane of symmetry of the seat forms an angle of less than  $+10^\circ$  or  $10^\circ$  with the vertical plane of symmetry of the vehicle.
- 3.23.3. "*Side-facing seat*" means a seat which can be used whilst the vehicle is in motion and which faces towards the side of the vehicle in such a manner that the vertical plane of symmetry of the seat forms an angle of  $90^\circ (\pm 10^\circ)$  with the vertical plane of symmetry of the vehicle.
- 3.24. "*Group of vehicle seats*" means either a bench seat or a plurality of seats which are separate but side by side (i.e. so fixed that the front anchorages of one seat are in line with the front or rear anchorages of another seat or on a line passing between those anchorages), each seat accommodating one or more seated adult persons.
- 3.25. "*Vehicle bench seat*" means a structure complete with trim and intended to seat more than one adult person.
- 3.26. "*Seat type*" means seats which do not differ essentially with respect to the following characteristics likely to affect their strength and their aggressiveness:
  - 3.26.1. Structure, shape, dimensions and materials of the load bearing parts;
  - 3.26.2. Types and dimensions of the seat back adjustment and locking system;
  - 3.26.3. Dimensions, structure and materials of the attachments and supports (e.g. legs);
- 3.27. "*Adjustment system*" means the device by which the seat or its parts can be adjusted to a position suited to the seated occupant;
- 3.28. "*Vehicle seat anchorage*" means the system, including the affected parts of the vehicle structure, by which the adult seat as a whole is secured to the vehicle structure.
- 3.29. "*Locking system*" means a device ensuring that the adult seat and its parts are maintained in the position of use.
- 3.30. "*Seat bight*" means the area close to the intersection of the surfaces of the vehicle seat cushion and the seat-back.
- 3.31. "*Type approval test*", means a test to determine the extent to which a Child Restraint Systems type submitted for approval is capable of satisfying the requirements.
- 3.32. "*Routine testing*" (or conformity of production testing), means the testing of a number of restraint systems selected from a single batch to verify the extent to which they satisfy the requirements.
- 3.33. "*Shoulder strap positioner*" means a device intended to maintain, the appropriate shoulder strap position on the child's torso, during normal transit conditions by connecting the shoulder straps to one another.
- 3.34. "*Lock-off device*" locks and prevents movement of one section of the webbing of an adult safety-belt relative to another section of the webbing of the same belt. Such devices may act upon either the diagonal or the lap sections or secure together both lap and diagonal sections of the adult belt. The term covers the following classes:

- 3.34.1. "*Class A device*" prevents the child from pulling the webbing of the retractor through to the lap part of the belt, when the adult belt is used to restrain the child directly (Non-Integral Child Restraint System).
- 3.34.2. "*Class B device*" allows the retention of an applied tension in the lap part of an adult safety-belt, when the adult belt is used to restrain Integral Child Restraint System. The device intends to prevent the webbing from slipping from the retractor through the device, which would release the tension and place the restraint in a non-optimal position.
- 3.35. "*Insert*" means a part of a CRS that provides additional support to a child and is an essential means to comply with all requirements for the entire or a part of the declared stature range.

## **4. Application for approval**

- 4.1. The application for approval of a type of Child Restraint System shall be submitted by the holder of the trade mark or by his duly accredited representative.
- 4.2. The application for approval, relating to each type of Child Restraint System, shall be accompanied by:
  - 4.2.1. A technical description of the Child Restraint System, specifying the straps and other materials used together with the predicted and reproducible behavior of load limiting devices. It shall be accompanied by drawings of the parts making up the Child Restraint System and in the case of retractors, installation instructions for these retractors and their sensing devices, declaration on toxicity (paragraph 7.3.1.1. of this Regulation), the drawings shall show the position intended for a single approval number and additional symbol(s) in relation to the circle of the approval mark;
  - 4.2.2. Samples of the Enhanced Child Restraint System requested by the Technical Service responsible for conducting the test;
  - 4.2.3. A 10-metre length of each type of strap used in the Enhanced Child Restraint System;
  - 4.2.4. Annex 11 lists the minimum documents required to accompany the application for approval as indicated in paragraph 4.2. above and required elsewhere in this Regulation.

## **5. Markings**

- 5.1. The following information shall be clearly indicated on the product:
  - (a) The size range(s) of the Child Restraint System in centimeters;
  - (b) The maximum occupant mass allowed for the Integral Child Restraint System in kilograms.
- 5.2. Integral Child Restraint Systems that can be used forward and rearward facing, shall have the following label permanently attached on the part hosting the child and visible to the person installing the Child:

The manufacturer shall be permitted to include the word "months" to explain the symbol "M" in the label. The word "months" should be in a language commonly spoken in the country or countries where the vehicle with the Child Restraint System is registered. More than one language is allowed.

Minimum label size 40 x 40 mm.

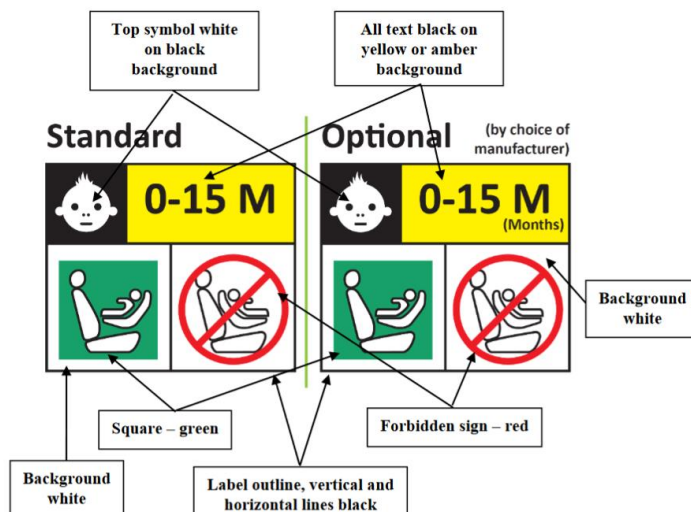

Integral Child Restraint Systems that can be used forward facing only shall have the following label permanently attached on the part hosting the child and visible to the person installing the child:

The manufacturer shall be permitted to include the word "months" to explain the symbol "M" in the label. The word "months" should be in a language commonly spoken in the country or countries where the vehicle is registered. More than one language is allowed.

Minimum label size 40 x 40 mm

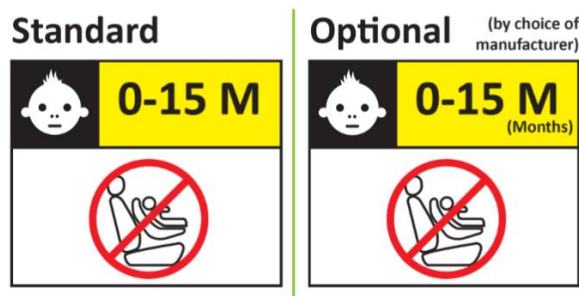

5.3.

Webbing path.

The markings defined in this paragraph shall be permanently and durably attached and visible on the Child Restraint System, and with the child seated in the Restraint System. The vehicle seat illustrated on the marking shall face the same direction as the actual vehicle seat.

There shall be a clear differentiation between the intended paths for the lap section and the diagonal section of the safety-belt. Indication such as color coding, words, shapes, etc. shall distinguish between sections of the adult safety-belt.

5.3.1.

The adult safety-belt route markings shall be placed on all belt guides and lock off devices. The adult safety-belt route markings shall be at least the width of the adult webbing path.

5.3.2.

For Non-Integral Child Restraint System to be used in combination with an adult safety-belt to restrain the child, the correct webbing path shall be clearly marked on the product. This shall be by means of an installation drawing on a label permanently attached to the Child Restraint System that shows the correct path across the child's body. The color used for the adult belt route marking of the safety-belt when the device is installed shall be

green. The same color shall also be used for the webbing path on the labels on the device that illustrate the installation.

- 5.4. An impact shield that is not permanently attached to the seat shall have a permanently attached label to indicate the brand and model of the Child Restraint System to which it belongs and the size range. The minimum size of the label shall be 40 × 40mm or the equivalent area.
- 5.5. Any removable insert, shall have a permanently attached label to indicate the brand, model and size range of the Enhanced Child Restraint System to which it belongs. The minimum size of the label shall be 40 x 40 mm or the equivalent area.
- 5.6. Child Restraint Systems shall have a permanently attached label to inform the user of the appropriate method of restraint of the child over the entire stature range declared by the manufacturer. The label shall be visible to the person installing the enhanced child restraint system in a vehicle and when a child is seated in the restraint. The label shall have a minimum size of 40 × 60mm or the equivalent area and shall feature a pictogram of each restraint configuration adjacent to the stature range.
- If the Child Restraint System is to be used in combination with an impact shield and/or inserts, the information on where they are stowed shall be available.
- 5.7. Additional information on how to install the child shall be provided by either a webpage or QR code permanently attached to the CRS.

## **6. Approval**

- 6.1. Each sample submitted in conformity with paragraphs 4.2.2. and 4.2.3. above shall meet the specifications set forth in paragraph 7. of this Regulation in every respect before approval can be granted.
- 6.2. An approval number shall be assigned to each type approved. Its first two digits shall indicate the series of amendments. The same Contracting Party shall not assign the same number to another type of Child Restraint System covered by this Regulation.
- A type of Child Restraint System approved according to this Regulation shall not bear another approval mark according to any other Regulation regarding CRS.
- 6.3. Notice of approval or of extension or refusal of approval of a Child Restraint Systems pursuant to this Regulation shall be communicated to the Parties to the Agreement which apply this Regulation by means of a form conforming to the model in Annex 1 to this Regulation.
- 6.4. In addition to the marks prescribed in paragraph 5. above, the following particulars shall be affixed in a suitable space to every Child Restraint System conforming to a type approved under this Regulation:
- 6.4.1. An international approval mark consisting of:
- 6.4.1.1. A circle surrounding the letter "E" followed by the distinguishing number of the country which has granted approval;<sup>1</sup>

---

<sup>1</sup> The distinguishing numbers of the Contracting Parties to the 1958 Agreement are reproduced in Annex 3 to the Consolidated Resolution on the Construction of Vehicles (R.E.3), document ECE/TRANS/WP.29/78/Rev.7, Annex 3 - <https://unece.org/transport/standards/transport/vehicle-regulations-wp29/resolutions>



- 6.4.1.2. An approval number, the words "Regulation No." followed by the number of this Regulation, a slash and the series of amendment ("Regulation No. XXX/XX");
- 6.4.2. The following additional symbols:
- 6.4.2.1. The size range for which the Child Restraint System has been designed;
- 6.4.2.2. The symbol "S" in the case of a "Special Needs Restraint".
- 6.5. Annex 2 to this Regulation gives an example of the arrangement of the approval mark.
- 6.6. The particulars referred to in paragraph 6.4. above shall be clearly legible and be indelible and may be affixed either by means of a label or by direct marking. The label or marking shall be resistant to wear.
- 6.7. The labels referred to in paragraph 6.4. above may be issued either by the Type Approval Authority which has granted the approval or, subject to that Type Approval Authority's authorization, by the manufacturer.

## **7. General specifications**

- 7.1. Positioning and securing of the child.
- 7.1.1. For children under the age of 15 months only lateral facing or rearward facing Child Restraint System shall be used.
- That means:
- (a) A rearward facing Child Restraint System designed for children up to 15 months of age shall accommodate a child with a stature up to 83 cm as a minimum;
  - (b) A forward facing Child Restraint System shall not be designed to accommodate a stature below 76 cm;
  - (c) A convertible seat in its rearward facing configuration shall be able to accommodate a child with a stature up to 83 cm. This shall not preclude a child stature greater than 83 cm
- The use of rearward facing Child Restraint System may be applied to any age of child.
- A rearward facing CRS shall not be installed in a rear facing vehicle seat.
- 7.1.2. For non-integral Child Restraint Systems, type approval shall not be granted for a stature below 100 cm. Non-integral Child Restraint Systems shall not be declared for use below a stature of 100 cm.
- Non integral CRS shall not be approved with an upper stature limit of 105 cm or below.
- CRS shall accommodate an uninterrupted range of child statures.
- Note: For example, it shall not accommodate children of 100 cm to 130 cm and then children of 140 cm to 150 cm with an "interruption".
- 7.1.3. Non-integral Child Restraint Systems shall have a main load-bearing contact point, between the Child Restraint System and the adult safety belt. This point shall not be less than 150 mm from the Cr axis when measured with the Child Restraint System.
- This shall apply to all adjustment setups and webbing paths.
- 7.2. Configuration of the Child Restraint System
- 7.2.1. The configuration of the Child Restraint System shall be such that

7.2.1.1. The restraint of the child shall give the required protection in any position specified for the Child Restraint System.

Inserts shall form only one layer on the seat surface. This does not preclude the use of additional ‘comfort’ inserts, provided they are not needed to comply with the requirements of the regulation.

For "Special Needs Restraints" the primary means of restraint shall give the required protection in any intended position of the Child Restraint System without the use of the additional restraining devices which may be present.

7.2.1.2. The Child Restraint System shall be such that the child may be easily and readily restrained or remove.

For Special Needs Restraints it is recognized that the additional restraining devices will restrict the speed by which a child can be restrained and removed. However, the additional devices shall be designed to release quickly so far as possible.

7.2.1.3. If it is possible to change the inclination of the Child Restraint System, this change in inclination shall not require manual readjustment of any other part of the Child Restraint System. A deliberate hand-action shall be necessary in order to change the inclination of the Child Restraint System.

7.2.1.4. To prevent submarining, either by impact or through restlessness, a crotch strap shall be required on all integral forward-facing restraints incorporating an integral harness belt system. Child Restraint Systems which incorporate a shield instead of a harness shall ensure that the shield extends across the full width of the child's body and sits low on the pelvis.

7.2.1.5. All restraint devices utilizing a lap strap shall positively guide the lap strap to ensure that the loads transmitted by the lap strap are transmitted through the pelvis. The assembly shall not subject weak parts of the child's body (abdomen, crotch, etc.) to excessive stresses

In the case of non-integral Child restraint Systems, the lap portion of the adult safety-belt shall be positively guided on both sides to ensure that the loads transmitted by the adult lap belt are transmitted through the pelvis. The positive guidance of loads over the pelvis shall be realized from the moment that the child is installed; the lap belt shall pass over the top of the thigh, just touching the fold with the pelvis. The angles  $\alpha$  and  $\beta$  between the tangent line in which the belt touches the thighs and the horizontal shall be greater than  $10^\circ$  as show in in figure 1.

Figure 1

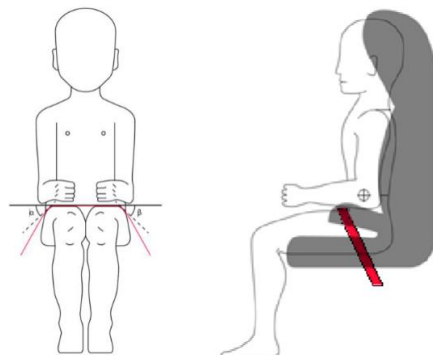

The shoulder portion of the adult safety belt shall be positively guided to ensure that the child torso and neck do not escape.

7.2.1.6. All straps of the restraint shall be so placed that they cannot cause discomfort to the wearer in normal use or assume a dangerous configuration. Y-shaped

belts are not permitted on forward facing Child Restraint Systems and may only be used in dedicated rearward facing and or lateral facing Child Restraint Systems. The distance between the shoulder-straps in the vicinity of the neck should be at least the width of the neck of the appropriate dummy.

- 7.2.1.7. With the crotch strap attached and in its longest position if adjustable, it shall not be possible to adjust the lap strap to lie above the pelvis of both the smallest and largest dummy within the size range covered by the approval. For all forward-facing restraints, it shall not be possible to adjust the lap strap to lie above the pelvis of both the smallest and largest dummy within the size range covered by the approval.
- An impact shield shall be adjustable so that it comes in contact with the pelvis and abdomen of the smallest and largest dummy within the size range covered by the approval, leaving no gap between the impact shield and the dummy.
- 7.2.2. The Child Restraint System shall be designed and installed so as to:
- 7.2.2.1. Not exhibit sharp edges or protrusions liable to cause damage to vehicle seat covers or to occupant's clothing.
- 7.2.2.2. To ensure that its rigid parts do not, at any point, where they are in contact with straps, exhibit sharp edges capable of abrading the straps.
- 7.2.2.3. It shall not be possible to remove or detach without the use of specific tools, any components except impact-shields or inserts not designed to be removable or detachable for maintenance purposes.
- 7.2.2.4. "Special Needs Restraints" may have additional restraining devices; these shall be designed to avoid any risk of incorrect assembly, and shall be designed so that their means of release and mode of operation is immediately obvious to any rescuer in an emergency.
- 7.2.2.5. A Child Restraint System may be designed for use in any size range specified by the manufacturer provided that it satisfies the requirements laid down in this Regulation.
- 7.2.2.6. Child Restraint Systems incorporating inflatable elements shall be so designed that the conditions of use (pressure, temperature, humidity) have no influence on their ability to comply with the requirements of this Regulation.
- 7.3. Child Restraint System specifications
- 7.3.1. Material
- 7.3.1.1. The Child Restraint System manufacturer shall declare in writing that the toxicity of materials used in the manufacture of restraint systems and accessible to the restrained child is in conformity with the test requirements of EN 71-3:2019, for a Category III material as defined in paragraph 4.2. Table 2 and following the test method of paragraph 7.2., specifically paragraph 7.2.2., Table 3, Category III sampling method. Tests confirming the validity of the declaration may be carried out at the discretion of the Technical Service. This paragraph does not apply to non-integral ECRS with a stature range of 100 cm or above.
- 7.3.2. General characteristics
- The manufacturer shall declare the maximum and minimum stature of the child that may use each configuration of the Child Restraint System.
- The stature range shall be verified by measuring the internal geometric characteristics according to paragraph 7.3.3.
- 7.3.3. Internal geometric characteristics

The Technical Service conducting the approval tests shall verify that the internal dimensions of the Enhanced Child Restraint System conform to the requirements of Annex 3. The minimum dimensions for shoulder breadth, hip breadth and sitting height shall be fulfilled simultaneously for any stature within the size range declared by the manufacturer.

Integral Child Restraint System shall also fulfil the minimum and maximum dimensions of shoulder height, for any stature within the size range declared by the manufacturer.

Integral Enhanced Child Restraint Systems that feature an impact shield shall also be capable of being adjusted to fulfil:

- (a) The 5th percentile upper leg thickness and 5th percentile abdomen depth, simultaneously to the 5th percentile shoulder height;
- (b) The 95th percentile upper leg thickness and 95th percentile abdomen depth, simultaneously to the 95th percentile shoulder height, shoulder breadth, hip breadth and sitting height.

For any stature within the size range declared by the manufacturer.

Non-integral Enhanced Child Restraint System shall also fulfil the maximum dimensions of shoulder height, for any stature within the size range declared by the manufacturer.

7.4. Control of markings

7.4.1. The Technical Service conducting the approval tests shall verify that the markings conform to the requirements of paragraph 5. of this Regulation

7.5. Provisions applicable to the Child Restraint System

The Child Restraint system shall fulfil the test requirements defined in the paragraph 8 of this Regulation.

## **8. Tests requirements**

8.1. Corrosion

8.1.1. A complete Child Restraint System, or the parts thereof that are liable to corrosion, shall be subject to the corrosion test specified in paragraph 8.1.3 below.

8.1.2. After the corrosion test as prescribed in paragraphs 8.1.3.1 and 8.1.3.2 below, no signs of deterioration likely to impair the proper functioning of the Child Restraint System, and no significant corrosion, shall be visible to the unaided eye of a qualified observer.

8.1.3. Corrosion test procedure

8.1.3.1 The metal items of the Child Restraint System shall be positioned in a test chamber as prescribed in Annex 4. In the case of a Child Restraint Systems System incorporating a retractor, the strap shall be unwound to full length less  $100 \pm 3$  mm. Except for short interruptions that may be necessary, for example, to check and replenish the salt solution, the exposure test shall proceed continuously for a period of  $50 \pm 0.5$  hours.

8.1.3.2. On completion of the exposure test the metal items of the Child Restraint System shall be gently washed, or dipped, in clean running water with a temperature not higher than  $38$  °C to remove any salt deposit that may have formed and then allowed to dry at room temperature of  $18$  °C to  $25$  °C for  $24 \pm 1$  hours before inspection in accordance with paragraph 6.6.1.2. above.

8.2. Overturning

- 8.2.1. The Child Restraint System shall be tested as prescribed in paragraph 8.2.2. of this Regulation, at no point during the whole test shall the manikin be fully ejected from the device, in addition when the Child Restraint System is in the upside down position the manikin's head shall not move more than 300 mm from its original position in a vertical direction, once the applied load has been removed.
- 8.2.2. The manikin shall be equipped with either of the load application devices as appropriate, and described in Annex 5 to this Regulation. Place the manikin in the restraints installed in accordance with this Regulation and taking into account the manufacturer's instructions and with the standard slack as specified in paragraph 8.3.7.1.1.9.1. below, applied for all systems identically.
- 8.2.2.1. The restraint shall be fastened to the vehicle seat. The whole Child Restraint System shall be rotated around a horizontal axis contained in the median longitudinal plane of the Child Restraint System through an angle of  $540^\circ \pm 5^\circ$  at a speed of 2-5 degrees/second and stopped in this position.
- 8.2.2.2. At this static inverted position a mass equivalent to 4 times that of the dummy, with a tolerance of -0/+5 per cent with reference to dummies nominal masses as in UN Regulation 129, shall be applied vertically downwards in a plane perpendicular to the axis of rotation in addition to the dummy utilizing the load application device described in Annex 5. The load shall be applied in a gradual controlled manner at a rate not exceeding gravitational acceleration or 400 mm/min.
- Maintain the prescribed maximum load for a duration of 30 -0/+5 seconds.
- 8.2.2.3. Remove the load at a rate not exceeding 400 mm/min and measure residual displacement.
- 8.2.2.4. Rotate the whole seat for  $180^\circ$  to return to the starting position.
- 8.2.2.5. This test cycle shall be carried out again rotating in the reverse direction.
- 8.2.2.6. These tests shall be carried out using both the smallest and the largest appropriate dummy of the size range for which the restraining device is intended. Any adjustment of the dummy or Child Restraint Systems during the complete test cycle is not allowed.
- 8.3. Dynamic
- 8.3.1. The dynamic test shall be performed on a Child Restraint Systems which have not previously been under load.
- 8.3.2. The Child Restraint System shall be tested with the vehicle seat which is intended.
- 8.3.3. In the case of a "Special Needs Restraint" every dynamic test specified by this Regulation for the range of size specified by the manufacturer shall be performed twice: first, using the primary means of restraint and second, with all restraining devices in use.
- 8.3.4. In the case of a Child Restraint System making use of or a shoulder strap positioner, the dynamic test shall be carried out as follows:
- 8.3.4.1. With shoulder strap positioner in use.
- 8.3.4.2. Without the shoulder strap positioner in use, unless:
- (a) A mechanism or;
  - (b) A visual and audible warning signal is provided to prevent incorrect use of the shoulder strap positioner.

- 8.3.5. At least the worst case of the dynamic test for the Child Restraint System shall be performed after conditioning according to paragraph 8.4.2.
- 8.3.6. During the dynamic tests, no part of the Child Restraint System affecting the restraint of the occupant shall fully or partially fracture, and no buckle, locking system or displacement system shall release or unlock. The only exception is where such parts or systems are identified as having a load limiting function in the manufacturer’s technical description, as defined in paragraph 4.2.1. of this Regulation, and they comply with the following criteria:
  - 8.3.6.1. During the dynamic tests, the safety-belt shall not become disengaged from any guide or locking device utilized for the test conducted; however, for the shoulder portion of the standard safety-belt this shall be judged up to the moment that the maximum horizontal head excursion of the dummy is reached.
  - 8.3.6.2. During the dynamic test, the lap belt shall not pass fully beyond the pelvic structure of the dummy during the period prior to maximum horizontal head excursion. An assessment shall be carried out using high speed video imaging.
  - 8.3.6.3. Perform as predicted by the manufacturer.
  - 8.3.6.4. Do not compromise the ability of the Child Restraint System to protect the occupant.
  - 8.3.6.5. Dummy criteria for frontal impact.
    - 8.3.6.5.1 Injury assessment criteria for frontal and rear impact as in Table 1.

Table 1

<i>Criterion</i>	<i>Abbreviation</i>	<i>Unit</i>	<i>Q0</i>	<i>Q1</i>	<i>Q1.5</i>	<i>Q3</i>	<i>Q6</i>	<i>Q10</i>
Head performance criterion (only in case of contact in vehicle-testing)	HPC * (15)		600	600	600	800	800	800
Resultant head acceleration 3 ms	A head Cum 3 ms ***	g	75	75	75	80	80	80
Upper neck tension Force	Fz	N						For monitoring purposes only **
Upper neck flexion moment	My	Nm						
Resultant chest acceleration 3 ms	A chest cum 3 ms ***	g	55	55	55	55	55	55
Chest deflection	TBC	mm	NA					For monitoring purposes only **
Abdominal pressure ****	P	Bar	NA	NA	1.2	1.0	1.0	1.2

\* HPC: see Annex 6 Appendix 2.

\*\* To be reviewed according to UN Regulation 129.

\*\*\* Cum 3ms means cumulative 3ms value.

\*\*\*\* Abdominal pressure, the highest recorded value is applicable for injury assessment (i.e., when the right handed sensors record 1.3 bar and the left handed sensor 1.0 bar, the recorded 1.3 bar is to be used for injury assessment).

- 8.3.6.6. Dummy's head displacement for frontal impact.
  - 8.3.6.6.1. No part of the head of the dummy shall pass beyond the planes BA as defined in Figure 2 below.
 

This shall be judged up to 300 ms or the moment that the dummy has come to a definitive standstill, whatever occurs first.

- 8.3.6.6.1.1. Where a test is conducted in accordance with paragraph 8.3.4.2. above, a tolerance of +10 per cent shall be applicable to the head excursion value distance between Cr point and plane AB.

Figure 2

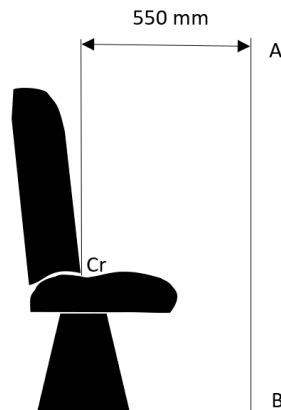

- 8.3.6.6.2. During the dynamic tests, no part of the Child Restraint System restraining the child in position shall fail. This includes buckles, locking systems and reclining systems, except were identified as a load limiting device.
- 8.3.7. Dynamic test procedure
- 8.3.7.1. Frontal impact tests shall be performed on all Child Restraint Systems within the scope of this regulation
- 8.3.7.1.1. Frontal impact tests.
- 8.3.7.1.1.1 The trolley shall remain horizontal throughout deceleration or acceleration.
- 8.3.7.1.1.2. The total velocity change of the trolley simulating the impact shall be between 30 and 32 km/h.
- 8.3.7.1.1.3. The deceleration or, at the choice of the applicant, acceleration of the trolley during the impact simulation shall be in accordance with the provisions shown in Annex 6 Appendix 1. Except for intervals totaling less than 3 ms, the curve of the trolley's deceleration or acceleration as function of time shall remain between the limit curves shown in Annex 6 Appendix 1.
- 8.3.7.1.1.4. Furthermore, the average deceleration or acceleration shall be comprised between 6.5 and 8.5 g.
- 8.3.7.1.1.5. The following measurements shall be made:
- 8.3.7.1.1.5.1. The trolley speed immediately before impact (only for deceleration sleds, needed for stopping distance calculation);
- 8.3.7.1.1.5.2. The displacement of the dummy's head in the horizontal direction.
- 8.3.7.1.1.5.3. The parameters required to perform the injury assessment against the criteria as mentioned in paragraph 8.3.6.5.1 above for at least the first 300 ms;
- 8.3.7.1.1.5.4. The trolley acceleration or deceleration for at least the first 300 ms.
- 8.3.7.1.1.6. After impact, the Child Restraint System shall be inspected visually, without opening the buckle, to determine whether there has been any failure or breakage.
- 8.3.7.1.1.7. The method used to secure the vehicle seat during the test shall not be such as to strengthen the anchorages of the vehicle seats, adult safety belts and

any additional anchorages required to secure the child restraint or to lessen the normal deformation of the structure.

8.3.7.1.1.8. The vehicle seat and Child Restraint System shall be fitted and placed in a position chosen by the Technical Service conducting the approval tests to give the most adverse conditions in respect of strength, compatible with installation of the dummy in the vehicle. The position of the vehicle seat-back and Child Restraint System shall be stated in the report. The vehicle seat-back, if adjustable for inclination, shall be locked as specified by the manufacturer.

8.3.7.1.1.9. Dynamic test dummies  
The Child Restraint System shall be tested using the dummies prescribed in Annex 8 of UN Regulation No. 129.

8.3.7.1.1.9.1. Installation of Integral  
The dummy shall be placed in the Child Restraint System separate from the seat-back of the chair by a flexible spacer. The spacer shall be 2.5 cm thick and 6 cm wide. It shall have length equal to the shoulder height less the thigh height, both in the sitting position and relevant to the dummy size being tested. The resulting height of the spacer is listed in the table 2 below for the different dummy sizes. The board should follow as closely as possible the curvature of the chair and its lower end should be at the height of the dummy's hip joint.

Table 2

<i>Q0</i>	<i>Q1</i>	<i>Q1.5</i>	<i>Q3</i>	<i>Q6</i>	<i>Q10</i>
Dimensions in mm					
173 ± 2	229 ± 2	237 ± 2	250 ± 2	270 ± 2	359 ± 2

Adjust the CRS belt in accordance with the manufacturer's instructions, but to a tension of 250 ± 25 N above the adjuster force, with a deflection angle of the strap at the adjuster of 45 ± 5°, or alternatively, the angle prescribed by the manufacturer.

The spacer shall then be removed and the dummy pushed towards to the seat back. Distribute the slack evenly throughout the harness.

8.3.7.1.1.9.2. Installation of non-Integral.  
The dummy shall be placed in the Child Restraint System.  
Pull the upper torso webbing out of the retractor horizontally at a position via the centre of the dummy and allow it to retract. Repeat this operation four times. The shoulder belt should be at the position between the area which shall not be taken off from shoulder and shall not contact with the neck. Apply a 9 to 18 N tension load to the lap belt. allow the excess webbing in the shoulder belt to be retracted by the rewind force of the retractor.

8.3.7.1.1.9.3. After installation.  
After installation, the dummy position shall be adjusted so that:  
The dummy center line shall be aligned exactly with the center line of Child Restraint System.

The arms of the dummy shall be positioned symmetrically. Elbows shall be positioned in such a way that the upper arms are closely aligned with the sternum.

Hands shall be positioned on the thighs.

Legs shall be positioned parallel to one another or at least symmetrically.



Example for arm alignment is show in in Figure 3:

Figure 3

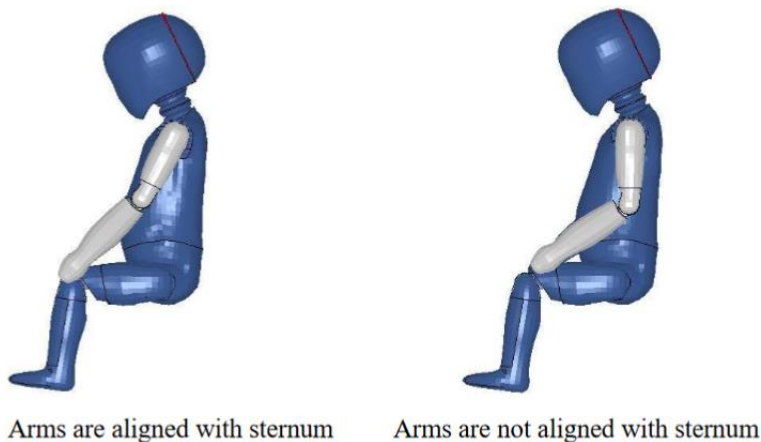

#### 8.3.7.1.1.9.4. Size indication

The dynamic tests shall be conducted with the largest dummy and the smallest dummy as defined in the following tables according to the size range indicated by the manufacturer for the Child Restraint System.

Table 3, Selection criteria for the dummy according to the range

Table 3

<i>Size range indication (in cm)</i>	$\leq 60$	$60 \leq X \leq 75$	$75 \leq X \leq 87$	$87 \leq X \leq 105$	$105 \leq X \leq 125$	$>125$
Dummy	Q0	Q1	Q 1.5	Q3	Q6	Q10

Where the Child Restraint System requires substantial modification for different sizes (e.g., convertible Child Restraint System) or if the size range cover more than 3 size ranges a relevant intermediate dummy(ies) shall be tested in addition to the dummy(ies) defined above.

If the Child Restraint System is designed for two or more children, one test shall be carried out with the heaviest dummies occupying all seating positions. A second test with the lightest and the heaviest dummies specified above shall be carried out. The laboratory conducting the tests may, if it deems it advisable, add a third test with any combination of dummies or empty seat positions.

#### 8.3.8. Registration of dynamic behavior

8.3.8.1. In order to determine the behavior of the dummy and its displacements, all dynamic tests shall be registered according to the following conditions:

##### 8.3.8.1.1. Filming and recording conditions:

- (a) The frequency shall be at least 1,000 frames per second;
- (b) The test shall be recorded on video or digital data carrier over at least the first 300 ms

##### 8.3.8.1.2. Estimation of uncertainty

Testing laboratories shall have and shall apply procedures for estimating uncertainty of measurement of the displacement of the dummy's head.

The uncertainty shall be within  $\pm 25$  mm.

Examples of international standards of such procedure are EA-4/02 of the European Accreditation Organization or ISO 5725:1994 or the General Uncertainty Measurement (GUM) method.

- 8.3.9. The measuring procedures shall correspond to those defined in the latest version of ISO 6487 with the SAE J211 sign convention. The channel frequency class shall be:

Table 4

<i>Type of measurement</i>	<i>CFC (<math>F_H</math>)</i>	<i>Cut-off frequency (<math>F_N</math>)</i>
Trolley acceleration	60	see ISO 6487Annex A-2015
Belt loads	60	see ISO 6487Annex A-2015
Chest acceleration	180	see ISO 6487Annex A-2015
Head acceleration	1000	1650 Hz
Upper neck force	1000	1650 Hz
Upper neck moment	600	1000 Hz
Chest deflection	600	1000 Hz
Abdominal pressure	180	see ISO 6487Annex A-2015

The sampling rate should be a minimum of 10 times the channel frequency class (i.e. in installations with channel frequency class of 1,000, this corresponds to a minimum sampling rate of 10,000 samples per second per channel)

- 8.4. Testing of individual components

8.4.1. Buckle

- 8.4.1.1. The buckle shall be so designed as to preclude any possibility of incorrect manipulation. This means, inter/alia, that it shall not be possible for the buckle to be left in a partially closed position; it shall not be possible to exchange the buckle parts inadvertently when the buckle is being locked; the buckle shall only lock when all parts are engaged. Wherever the buckle is in contact with the child, it shall not be narrower than the minimum width of strap as specified in paragraph 8.4.4.1.1. below. This paragraph is not applicable to belt assemblies already approved according to Regulation No. 16 or any equivalent standard in force. In the case of a "Special Needs Restraint" only the buckle on the primary means of restraint need comply with the requirements of paragraphs 8.4.1.2. to 8.4.1.7. inclusive

- 8.4.1.2. The buckle, even when not under tension, shall remain closed whatever its position. It shall be easy to operate and to grasp. It shall be possible to open it by pressure on a button or on a similar device.

The surface to which this pressure shall be applied shall have, in the position of actual unlocking and when projected into a plane perpendicular to the button's initial direction of motion:

- (a) For enclosed devices, an area of not less than 4.5 cm<sup>2</sup> with a width of not less than 15 mm;
- (b) For non-enclosed devices, an area of 2.5 cm<sup>2</sup> and a width of not less than 10 mm. The width shall be the smaller of the two

dimensions forming the prescribed area and shall be measured rectangular to the direction of movement of the release button.

- 8.4.1.3. The buckle release area shall be colored red. No other part of the buckle shall be of this color.
- 8.4.1.4. It shall be possible to release the child from the restraint by a single operation on a single buckle. A further single operation may be used to release a shoulder strap positioner, if any. In such cases, it shall be possible to release the shoulder strap positioner before as well as after release of the buckle, or simultaneously.
- 8.4.1.4.1. **Shoulder strap positioner**  
If a shoulder strap positioner is provided, it shall be designed so as to prevent incorrect manipulation. It shall not be possible to use the device in a manner which would cause the shoulder straps to twist. It shall be possible to fasten the device in no more than one action. The force required to fasten the device shall not exceed 15 N.
- 8.4.1.4.1.1. The shoulder strap positioner shall be easy to operate and to grasp. It shall be possible to open it in one simple action, but it shall be difficult for the child occupant to manipulate the release mechanism. The force required to release the device shall not exceed 15 N.
- 8.4.1.4.1.2. The shoulder strap positioner shall not exceed 60 mm in height.
- 8.4.1.5. Opening of the buckle shall enable the child to be removed independently of the "chair", "chair support" or "impact shield", if fitted, and if the device includes a crotch strap the crotch strap shall be released by operation of the same buckle.
- 8.4.1.6. The buckle shall be capable of withstanding the temperature test operation requirements given in paragraph 8.4.5 below and repeated operation, and shall, before the dynamic test prescribed in paragraph 8.3. undergo a test comprising  $5,000 \pm 5$  opening and closing cycles under normal conditions for use.
- 8.4.1.7. The buckle shall be subjected to the following tests of opening:
- 8.4.1.7.1. **Test under load**
- 8.4.1.7.1.1. An Enhanced Child Restraint Systems System having already undergone the dynamic test prescribed in paragraph 8.3. below shall be used for this test.
- 8.4.1.7.1.2. The force required to open the buckle in the test prescribed below shall not exceed 80 N.
- 8.4.1.7.1.2.1. The Child Restraint System shall be removed without opening the buckle. A tension of  $200 \pm 2$  N shall be applied to the buckle. If the buckle is attached to a rigid part, the force shall be applied reproducing the angle formed between the buckle and that rigid part during the dynamic test.
- 8.4.1.7.1.2.2. A load shall be applied at a speed of  $400 \pm 20$  mm/min to the geometric centre of the buckle-release button along a fixed axis running parallel to the initial direction of motion of the button; the geometric centre applies to that part of the surface of the buckle to which the release pressure is to be applied. The buckle shall be secured against a rigid support during the application of the opening force.
- 8.4.1.7.1.2.3. The buckle opening force shall be applied, using a dynamometer or similar device in the manner and direction of normal use. The contact end shall be a polished metal hemisphere with radius  $2.5 \pm 0.1$  mm.
- 8.4.1.7.1.2.4. The buckle opening force shall be measured and any failure noted.
- 8.4.1.7.2. **No-load test**

- 8.4.1.7.2.1. A buckle which has not previously been subjected to a load shall be used for this test. The force needed to open the buckle when it is not under load shall be in the range of 40–80 N in the tests prescribed below:
- 8.4.1.7.2.1.1. A buckle assembly which has not previously been subjected to a load shall be mounted and positioned under a no load condition.
- 8.4.1.7.2.1.2. The method of measuring the buckle opening force shall be as prescribed in paragraphs 8.4.1.7.1.2.2. and 8.4.1.7.1.2.3. above.
- 8.4.1.7.2.1.3. The buckle opening force shall be measured.
- 8.4.1.7.3. Strength
- 8.4.1.7.3.1. During the test prescribed below no part of the buckle or the adjacent straps or adjusters shall break or be detached.
- 8.4.1.7.3.2. Depending on the mass limit declared by the manufacturer, a buckle shall withstand:
- (a) 4 kN, if the mass limit is less or equal to 13 kg;
  - (b) 10 kN, if the mass limit is greater than 13 kg;
  - (c) The Type Approval Authority may dispense with the buckle strength test if information already available renders the test superfluous.
- 8.4.1.7.3.3. Strength testing
- 8.4.1.7.3.3.1. For the strength test two samples have to be used. All adjusters, except for adjusters mounted directly on an Enhanced Child Restraint Systems are included in the test.
- 8.4.1.7.3.3.2. Annex 7 shows a typical device for a buckle strength test. The buckle is placed on the upper round plate (A) within the relief. All adjacent straps have a length of at least 250 mm and are arranged hanging down from the upper plate respective to their position at the buckle. The free strap ends are then wound round the lower round plate (B) until they come out at the plate's inner opening. All straps have to be vertical between A and B. The round clamping plate (C) is then lightly clamped against the lower face of (B), still allowing a certain strap movement between them. With a small force at the tensile machine the straps are tensioned and pulled between (B) and (C) until all straps are loaded respective to their arrangement. The buckle shall stay free from plate (A) or any parts at (A) during this operation and the test itself. (B) and (C) are then clamped firmly together and the tensile force is increased at a traverse speed of  $100 \pm 20$  mm/min until the required values are reached.
- 8.4.2. Adjusting device
- 8.4.2.1. The range of adjustment shall be sufficient to permit correct adjustment of the Child Restraint System with all size for which the device is intended and to permit satisfactory installation in all i-Size compatible vehicles.
- 8.4.2.2. All adjusting devices shall be of the "quick adjuster" type.
- 8.4.2.3. Devices of the "quick adjuster" type shall be easy to reach when the Child Restraint System is correctly installed, and the child or dummy is in position.
- 8.4.2.4. A device of the "quick adjuster" type shall be easily adjustable to the child's physique. In particular, in a test performed in accordance with paragraph 8.4.2.5.1. below, the force required to operate a manual adjusting device shall not exceed 50 N.
- 8.4.2.5. The device shall not break or become detached when tested as prescribed in paragraph 8.4.2.5.1 below.
- 8.4.2.5.1. Ease of adjustment

- 8.4.2.5.1.1. When testing a manual adjusting device, the strap shall be drawn steadily through the adjusting device, having regard for the normal conditions of use, at a rate of  $100 \pm 20$  mm/min and the maximum force measured to the nearest integer value of N after the first  $25 \pm 5$  mm of strap movement.
- 8.4.2.5.1.2. The test shall be carried out in both directions of strap travel through the device, the strap being subjected to the full travel cycle 10 times prior to the measurement.
- 8.4.2.6. Two samples of the Child Restraint System adjusting devices shall be tested as prescribed by the temperature test operation requirements given in paragraph 8.4.5.
- 8.4.2.7. The amount of strap slip shall not exceed 25 mm for one adjusting device or 40 mm for all adjusting devices.
- 8.4.2.8. An adjuster mounted directly on the Child Restraint System shall be capable of withstanding repeated operation and shall, before the dynamic test prescribed in paragraph 8.3. undergo a test comprising  $5,000 \pm 5$  cycles as specified in paragraph 8.4.2.8.1.
- 8.4.2.8.1. Conditioning test for adjusters mounted directly on a CRS
- 8.4.2.8.1.1. Install the largest dummy for which the restraint is intended, as if for the dynamic test. Mark a reference line on the webbing where the free end of the webbing enters the adjuster.
- Remove the dummy and place the restraint in the conditioning rig shown in Figure 1, Annex 8.
- The webbing shall be cycled for a total distance of not less than 150 mm through the adjuster. This movement shall be such that at least 100 mm of webbing on the side of the reference line towards the free end of the webbing and the remainder of the moving distance (approx. 50 mm) on the integral harness side of the reference line moves through the adjuster. If the length of webbing from the reference line to the free end of the webbing is insufficient for the movement described above, the 150 mm of movement through the adjuster shall be from the fully extended harness position.
- The frequency of cycling shall be  $10 \pm 1$  cycles/minute, with a velocity on "B" of  $150 \pm 10$  mm/sec.
- 8.4.2.9. An adjuster mounted on a strap shall be capable of withstanding repeated operation and shall, before the dynamic test prescribed in paragraph 8.3. undergo a test comprising  $5,000 \pm 5$  cycles as specified in paragraph 8.4.2.9.1
- 8.4.2.9.1. Conditioning test for adjusters connected to a strap (not directly mounted to the Enhanced Child Restraint System).
- Install the largest dummy for which the restraint is intended, as if for the dynamic test. Mark a reference line on the strap where the free end of the strap enters the adjuster.
- Remove the dummy and place the restraint in the conditioning rig shown in Figure 2, Annex 8.
- The strap shall be cycled for a total distance of not less than 150 mm through the adjuster. This movement shall be such that at least 100 mm of strap on the side of the reference line towards the free end of the strap. If the length of strap from the reference line to the free end of the strap is insufficient for the movement described above, the 150 mm of movement through the adjuster shall be from the fully extended strap position.
- The frequency of cycling shall be  $10 \pm 1$  cycles/minute, with a velocity on 'B' of  $150 \pm 1$  mm/s.

This process shall be conducted for each adjuster that is part of the retention system of the child within the restraint

8.4.3. Microslip

8.4.3.1. The components or devices to be subjected to the microslip test shall be kept for a minimum of 24 hours before testing in an atmosphere having a temperature of  $20\text{ }^{\circ}\text{C} \pm 5\text{ }^{\circ}\text{C}$  and a relative humidity of  $65 \pm 5$  per cent.

The test shall be carried out at a temperature between  $15\text{ }^{\circ}\text{C}$  and  $30\text{ }^{\circ}\text{C}$ .

8.4.3.2. The free end of the strap shall be arranged in the same way as when the device is in use in the vehicle, and shall not be attached to any other part.

8.4.3.3. The adjusting device shall be placed on a vertical piece of strap one end of which bears a load of  $50 \pm 0.5\text{ N}$  (guided in a manner which prevents the load from swinging and the strap from twisting). The free end of the strap from the adjusting device shall be mounted vertically upwards or downwards as it is in the vehicle. The other end shall pass over a deflector roller with its horizontal axis parallel to the plane of the section of strap supporting the load, the section passing over the roller being horizontal.

8.4.3.4. The device being tested shall be arranged in such a way that its centre, in the highest position to which it can be raised, is  $300 \pm 5\text{ mm}$  from a support table, and the load of  $50\text{ N}$  shall be  $100 \pm 5\text{ mm}$  from that support table.

8.4.3.5.  $20 \pm 2$  pre-test cycles shall then be completed and  $1,000 \pm 5$  cycles shall then be completed at a frequency of  $30 \pm 10$  cycles per minute, the total amplitude being  $300 \pm 20\text{ mm}$ . The  $50\text{ N}$  load shall be applied only during the time corresponding to a shift of  $100 \pm 20\text{ mm}$  for each half period. Microslip shall be measured from the position at the end of the 20 pre-test cycles.

8.4.4. Straps

8.4.4.1. Width

8.4.4.1.1. The minimum width at the child-restraint straps which contact the dummy shall be  $25\text{ mm}$ . These dimensions shall be measured during the strap strength test prescribed in paragraph 8.4.4.3.5. below, without stopping the machine and under a load equal to 75 per cent of the breaking load of the strap.

8.4.4.2. Strength after room conditioning

8.4.4.2.1. On two sample straps conditioned as prescribed in paragraph 8.4.4.3.6.1, the breaking load of the strap shall be determined as prescribed in paragraph 8.4.4.3.6.2. below.

8.4.4.2.2. The difference between the breaking loads of the two samples shall not exceed 10 per cent of the greater of the two breaking loads measured.

8.4.4.3. Strength after special conditioning

8.4.4.3.1. On two straps conditioned as prescribed in one of the provisions of paragraph 8.4.4.3.6. below (except para. 8.4.4.3.6.1. below), the breaking load of the strap shall be not less than 75 per cent of the average of the loads determined in the test referred to in paragraph 8.4.4.3.6.1. below.

8.4.4.3.2. In addition, the breaking load shall be not less than  $3.6\text{ kN}$  for the restraints of Child Restraint Systems.

8.4.4.3.3. The Type Approval Authority may dispense with one or more of these tests if the composition of the material used, or information already available, renders the test or tests superfluous.

- 8.4.4.3.4. The abrasion conditioning procedure of type 1 defined in paragraph 8.4.4.3.6.6. below shall only be performed when the microslip test defined in paragraph 8.4.3. below gives a result above 50 per cent of the limit prescribed in paragraph 8.4.2.7. above.
- 8.4.4.3.5 Strap strength test
- 8.4.4.3.5.1. Each test shall be carried out on two new samples of strap conditioned as specified in paragraph 8.4.4. of this Regulation
- 8.4.4.3.5.2. Each strap shall be gripped between the clamps of a tensile strength-testing machine. The clamps shall be so designed as to avoid breakage of the strap at or near them. The speed of traverse shall be  $100 \pm 20$  mm/min. The free length of the specimen between the clamps of the machine at the start of the test shall be  $200 \text{ mm} \pm 40 \text{ mm}$
- 8.4.4.3.5.2.1. The tension shall be increased until the strap breaks and the breaking load noted.
- 8.4.4.3.5.3. If the strap slips or breaks at or within 10 mm of either of the clamps, the test shall be invalid and a new test shall be carried out on another specimen.
- 8.4.4.3.6. Samples out from straps, as referred to in paragraph 4.2.3. of this Regulation, shall be conditioned as follows:
- 8.4.4.3.6.1. Room conditioning
- 8.4.4.3.6.1.1. The strap shall be kept for  $24 \pm 1$  hours in an atmosphere having a temperature of  $23 \text{ }^\circ\text{C} \pm 5 \text{ }^\circ\text{C}$  and a relative humidity of  $50 \pm 10$  per cent. If the test is not carried out immediately after conditioning, the specimen shall be placed in a hermetically closed receptacle until the test begins. The breaking load shall be determined within five minutes after removal of the strap from the conditioning atmosphere or from the receptacle.
- 8.4.4.3.6.2. Light conditioning
- 8.4.4.3.6.2.1. The provisions of Recommendation ISO/105-B02 (1978), shall apply. The strap shall be exposed to light for the time necessary to produce fading of Standard Blue Dye No. 7 to a contrast equal to Grade 4 on the grey scale.
- 8.4.4.3.6.2.2. After exposure, the strap shall be kept for a minimum of 24 hours in an atmosphere having a temperature of  $23 \text{ }^\circ\text{C} + 5 \text{ }^\circ\text{C}$  and a relative humidity of  $50 \pm 10$  per cent. The breaking load shall be determined within five minutes after the removal of the strap from the conditioning installation.
- 8.4.4.3.6.3. Cold conditioning
- 8.4.4.3.6.3.1. The strap shall be kept for a minimum of 24 hours in an atmosphere having a temperature of  $23 \text{ }^\circ\text{C} \pm 5 \text{ }^\circ\text{C}$  and a relative humidity of  $50 \pm 10$  per cent.
- 8.4.4.3.6.3.2. The strap shall then be kept for  $90 \pm 5$  minutes on a plain surface in a low-temperature chamber in which the air temperature is  $-30 \text{ }^\circ\text{C} \pm 5 \text{ }^\circ\text{C}$ . It shall then be folded and the fold shall be loaded with a weight of  $2 \pm 0.2$  kg previously cooled to  $-30 \text{ }^\circ\text{C} \pm 5 \text{ }^\circ\text{C}$ . When the strap has been kept under load for  $30 \pm 5$  minutes in the same low-temperature chamber, the weight shall be removed and the breaking load shall be measured within five minutes after removal of the strap from the low-temperature chamber.
- 8.4.4.3.6.4. Heat conditioning
- 8.4.4.3.6.4.1. The strap shall be kept for  $180 \pm 10$  minutes in a heating-cabinet atmosphere having a temperature of  $60 \text{ }^\circ\text{C} \pm 5 \text{ }^\circ\text{C}$  and a relative humidity  $65 \pm 5$  per cent.
- 8.4.4.3.6.4.2. The breaking load shall be determined within five minutes after removal of the strap from the heating cabinet.
- 8.4.4.3.6.5. Exposure to water

- 8.4.4.3.6.5.1. The strap shall be kept fully immersed for  $180 \pm 10$  minutes in distilled water, at a temperature of  $20 \text{ }^\circ\text{C} \pm 5 \text{ }^\circ\text{C}$ , to which a trace of wetting agent has been added. Any wetting agent suitable for the fibre being tested may be used.
- 8.4.4.3.6.5.2. The breaking load shall be determined within 10 minutes after removal of the strap from the water.
- 8.4.4.3.6.6. Abrasion conditioning
- 8.4.4.3.6.6.1. The components or devices to be submitted to the abrasion test shall be kept for a minimum of 24 hours before testing in an atmosphere having a temperature of  $23 \text{ }^\circ\text{C} \pm 5 \text{ }^\circ\text{C}$  and a relative humidity of  $50 \pm 10$  per cent. The room temperature during the testing shall be between  $15 \text{ }^\circ\text{C}$  and  $30 \text{ }^\circ\text{C}$ .
- 8.4.4.3.6.6.2. The table below sets out the general conditions for each test:

Table 5

	<i>Load (N)</i>	<i>Cycles per minute</i>	<i>Cycles (No.)</i>
Type 1 procedure	Maximum $60 \pm 0.5$	$30 \pm 10$	$1\ 000 \pm 5$
Type 2 procedure	Minimum $10 \pm 0.10$	$30 \pm 10$	$5\ 000 \pm 5$

Where there is insufficient strap to test over 300 mm of shift, the test may be applied over a shorter length subject to a minimum of 100 mm.

- 8.4.4.3.6.6.3. Particular test conditions
- 8.4.4.3.6.6.3.1. Type 1 procedure: for cases where the strap slides through the quick adjusting device. Apply a load of 10 N, if necessary the load may be increased by 10 N steps so as to permit correct sliding, but limited to a maximum of 60 N. This load shall be vertically and permanently applied on the straps. The part of the strap set horizontally shall pass through the quick adjuster it is fitted to and shall be attached to a device, giving the webbing a back and forth motion. The quick adjusting device shall be so placed that the horizontal strap of the webbing remains under tension (see Annex 10, Figure 1). Activate the quick adjuster while pulling the straps in the direction to slacken the harness and deactivate it while pulling the straps in the direction to tighten the harness.
- 8.4.4.3.6.6.3.2. Type 2 procedure: for cases where the strap changes direction when passing through a rigid part. During this test, the webbing shall pass through the rigid part it is intended for and the test set-up shall reproduce the angles as in the real installation (in three dimensions), see Annex 10, Figure 2 for examples. The 10 N load shall be permanently applied. For cases where the strap changes direction more than once when passing through a rigid part, the load of 10 N may be increased by 10 N steps so as to permit correct sliding and achieve the prescribed 300 mm of strap movement through that rigid part.
- 8.4.4.4. It shall not be possible to pull the complete strap through any adjusters, buckles or anchoring points.
- 8.4.5 Temperature
- 8.4.5.1. Buckle assemblies, retractors, adjusters and lock-off devices that are liable to be affected by temperature, shall be subject to the temperature test specified in paragraph 8.4.5.3. below. This requirement is applicable to any such components that are found on the Enhanced Child Restraint System, regardless of the means of restraint.
- 8.4.5.2. After the temperature test as prescribed in paragraph 8.4.5.3. below, no signs of deterioration likely to impair the proper functioning of the restraint of the child, shall be visible to the unaided eye of a qualified observer. The dynamic tests should then be performed.



- 8.4.5.3. The components specified in paragraph 8.4.5.1. above shall be exposed to an environment over a water surface within a closed space, the environment having a temperature of not less than 80 °C, for a continuous period of not less than 24 hours and then cooled in an environment having a temperature not exceeding 23 °C. The cooling period shall immediately be followed by three consecutive 24 hour cycles with each cycle comprising the following consecutive sequences:
- (a) An environment having a temperature of not less than 100 °C shall be maintained for a continuous period of 6 hours and this environment shall be attained within 80 minutes of commencement of the cycle; then
  - (b) An environment having a temperature of not more than 0 °C shall be maintained for a continuous period of 6 hours and this environment shall be attained within 90 minutes; then
  - (c) An environment having a temperature of not more than 23 °C shall be maintained during the remainder of the 24 hour cycle.

## 9. Test reports of type approval

- 9.1. The test report shall record the results of all tests and measurements including the following test data:
- (a) The type of device used for the test (acceleration or deceleration device),
  - (b) The trolley speed immediately before impact only for deceleration sleds,
  - (c) The acceleration or deceleration curve during all the velocity change of the trolley and at least 300 ms,
  - (d) The time (in ms) when the head of the manikin reaches its maximum displacement during the performance of the dynamic test,
  - (e) The place occupied by the buckle during the tests, if it can be varied, and
  - (f) The name and address of the laboratory where tests have been performed,
  - (g) And any failure or breakage,
  - (h) The following dummy criteria: HPC, Resultant head acceleration Cum 3ms, Upper neck tension force, Upper neck moment, Resultant chest acceleration Cum 3ms, Chest deflection; Abdominal Pressure; and
  - (i) The minimum and maximum approved stature range for the CRS.
- 9.2.2. The test reports shall record the verification of markings and of instructions on installation and use.
- 9.2.3. The evidences for all the requirements and specifications defined above in paragraphs 7 and 8 shall be detailed in the test report.

## 10. Conformity of production and routine tests

The conformity of production procedures shall comply with those set out in the Agreement, (Schedule 1 E/ECE/TRANS/505/Rev.3), with the following requirements:

- 10.1. Suitable controls of the production shall be carried out. In this case, suitable controls mean checking the dimensions of the product as well as the existence of procedures for the effective control of the quality of products as to conform to the type approved by meeting the requirements set forth in paragraphs 7. to 8. above.
- 10.2. The competent authority which has granted the Type Approval may at any time verify the conformity control methods applicable to each production unit and carry out on samples any test deemed necessary among the tests carried out for the approval. The normal frequency of these verifications shall be once a year.

## **11. Modification and extension of approval of a Child Restraint System**

- 11.1. Every modification of a Child Restraint System shall be notified to the Type Approval Authority which approved the Child Restraint System. The Type Approval Authority may then either:
- 11.1.1. Consider that the modifications made are unlikely to have an appreciable adverse effect and that in any case the Child Restraint System still complies with the requirements; or
- 11.1.2. Require a further test report from the Technical Service responsible for conducting the tests.
- 11.2. Confirmation or refusal of approval, specifying the alterations, shall be communicated by the procedure specified in paragraph 6.3. above to the Contracting Parties to the Agreement applying this Regulation.
- 11.3. The Type Approval Authority issuing the extension of approval shall assign a series number for such an extension and inform thereof the other Contracting Parties to the 1958 Agreement applying this Regulation by means of a communication form conforming to the model in Annex 1 to this Regulation.

## **12. Penalties for non-conformity of production**

- 12.1. The approval granted in respect of an Child Restraint System pursuant to this Regulation may be withdrawn if an Child Restraint System bearing the particulars referred to in paragraph 6.4. of this Regulation does not conform to the type approved.
- 12.2. If a Contracting Party to the Agreement which applies this Regulation withdraws an approval it has previously granted, it shall forthwith so notify the other Contracting Parties applying this Regulation by means of a communication form conforming to the model in Annex 1 to this Regulation.

## **13. Production definitively discontinued**

- 13.1. If the holder of the approval completely ceases to manufacture a specific type of Child Restraint System under this Regulation, he shall inform thereof the Type Approval Authority which granted the approval. Upon receiving the relevant communication, that Type Approval Authority shall inform the other Contracting Parties to the Agreement which apply this Regulation by means of a communication form conforming to the model in Annex 1 to this Regulation

**14. Names and addresses of Technical Services responsible for conducting approval tests and of Type Approval Authorities**

The Contracting Parties to the 1958 Agreement applying this Regulation shall communicate to the United Nations Secretariat the names and addresses of the Technical Services responsible for conducting approval tests and of the Type Approval Authorities which grant approval and to which forms certifying approval or extension or refusal or withdrawal of approval, or production definitively discontinued, issued in other countries, are to be sent.

**Annex 1**

**Communication Concerning the Approval or Refusal or Extension or Withdrawal of Approval or Production Definitively Discontinued of Child Restraint Systems for Safer Transport of Children in Buses and Coaches**

(Maximum format: A4 (210 x 297 mm))



issued by:

(Name of administration)

.....  
 .....  
 .....

- Concerning: <sup>2</sup>
- Approval granted
  - Approval extended
  - Approval refused
  - Approval withdrawn
  - Production definitively discontinued

of restraining systems for child occupants of Buses and Coaches, pursuant to UN Regulation No. [XXX]

Approval No.: .....

- 1.1. Forward-facing child restraint/rearward-facing child restraint/lateral-facing child restraint: .....
- 1.2. Integral/Non integral;
- 1.3. Belt type: <sup>2</sup>  
 (Adult) three-point belt <sup>2</sup>  
 Special type belt/retractor <sup>2</sup>
- 1.4. Other features: chair assembly/impact shield<sup>2</sup> .....
2. Trade name or mark.....
3. Manufacturer's designation of the Child Restraint System.....
4. Manufacturer's name .....
5. If applicable, name of his representative.....
6. Address .....
7. Submitted for approval on .....
8. Technical Service conducting approval tests .....
9. Type of device: deceleration/acceleration<sup>2</sup>.....
10. Date of test report issued by that Service .....
11. Number of test report issued by that Service .....
12. Approval granted/extended/refused/withdrawn<sup>2</sup> for size range x to x .....
13. Position and nature of the marking.....

<sup>1</sup> Distinguishing number of the country which has granted/extended/refused/withdrawn an approval (see approval provisions in this Regulation).

<sup>2</sup> Strike out what does not apply.

- 
14. Place.....
15. Date.....
16. Signature .....
17. The following documents, bearing the approval number shown above, are attached to this communication:
- (a) Drawings, diagrams and plans of the child restraint, including any retractor, chair assembly, impact shield fitted;
  - (b) Drawings, diagrams and plans of the vehicle structure and the seat structure, as well as of the adjustment system and the attachments, including any energy absorber fitted;
  - (c) Photographs of the child restraint and/or vehicle structure and seat structure;
  - (d) Instructions for fitting and use;
  - (e) List of vehicle models for which the restraint is intended.

## Annex 2

### Arrangements of Approval Marks

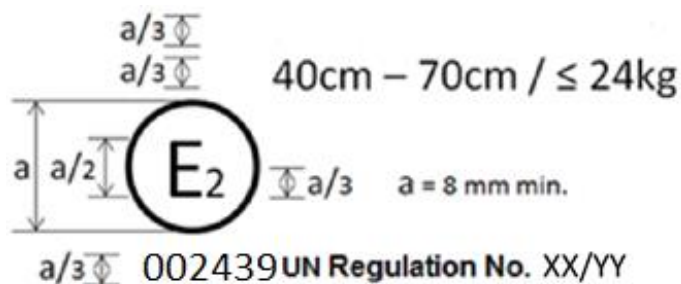

The Child Restraint System which bear the above approval mark is a device being used for 40 cm - 70 cm size range and mass limit of 24 kg; it is approved in France (E 2) under the number 002439. The approval number indicates that the approval was granted in accordance with the requirements of the UN Regulation concerning the approval of Safer Transport of Children in Buses and Coaches as amended by the YY series of amendments. In addition the name of the regulation has to be identified on the approval mark followed by the series of amendment according to which the approval has been granted.

### Annex 3

#### Internal measurements

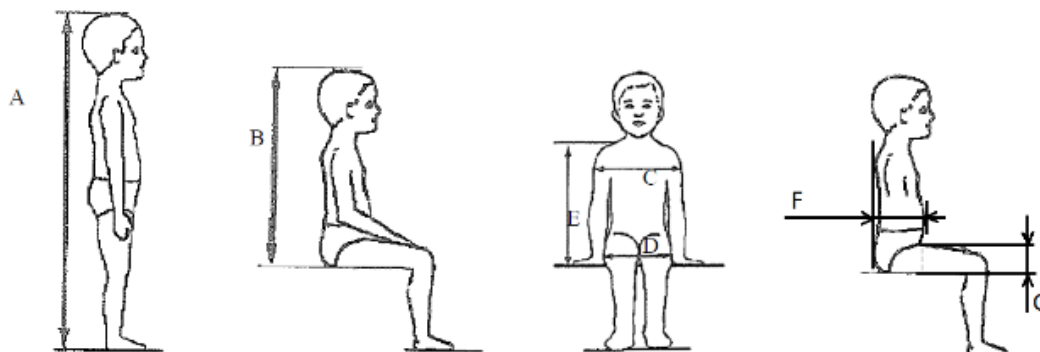

Applicable to all CRS						Additional internal dimensions for CRS with impact shields systems			
	Min	Min	Min	Min	Max	Min	Max	Min	Max
Stature	Sitting height cm	Shoulder breadth cm	Hip breadth cm	Shoulder height cm	Shoulder height cm	Abdomen depth cm	Abdomen depth cm	Upper leg thickness cm	Upper leg thickness cm
A	B	C	D	E1	E2	F1	F2	G1	G2
	95%ile	95%ile	95%ile	5%ile	95%ile	5%ile	95%ile	5%ile	95%ile
≤ 40				< 27.4					
45	39.0	12.1	14.2	27.4	29.0				
50	40.5	14.1	14.8	27.6	29.2				
55	42.0	16.1	15.4	27.8	29.4				
60	43.5	18.1	16.0	28.0	29.6				
65	45.0	20.1	17.2	28.2	29.8				
70	47.1	22.1	18.4	28.3	30.0				
75	49.2	24.1	19.6	28.4	31.3				
80	51.3	26.1	20.8	29.2	32.6	12.5	15.1	5.7	8.4
85	53.4	26.9	22.0	30.0	33.9	12.7	15.7	5.8	8.4
90	55.5	27.7	22.5	30.8	35.2	12.9	16.2	5.9	8.5
95	57.6	28.5	23.0	31.6	36.5	13.1	16.8	6.2	8.5
100	59.7	29.3	23.5	32.4	37.8	13.3	17.8	6.5	8.9
105	61.8	30.1	24.9	33.2	39.1	13.5	18.2	6.5	9.6
110	63.9	30.9	26.3	34.0	40.4	13.6	18.8	6.6	10.3
115	66.0	32.1	27.7	35.5	41.7	13.9	19.6	6.6	10.3
120	68.1	33.3	29.1	37.0	43.0	13.9	19.9	6.6	10.4
125	70.2	33.3	29.1	38.5	44.3	14.3	20.2	6.8	10.5
130	72.3	33.3	29.1	40.0	46.1	14.7	20.7	7.5	10.9
135	74.4	33.3	29.1	41.5	47.9				
140	76.5	34.2	29.6	43.0	49.7				
145	78.6	35.3	30.8	44.5	51.5				
150	81.1	36.4	32.0	46.3	53.3				

Not allowed for three dimensions and stature below 76 cm

Not allowed for these dimensions and stature over 125 cm

All lateral dimensions are measured under a contact force of 50 N with the devices described in Figure 2 and Figure 3 of this annex and the following tolerances will be applied:

Minimum Sitting height:

- (a) Up to 87 cm B - 5 per cent;
- (b) From stature from 87 cm and up to 150 cm B - 10 per cent;
- (c) Minimum shoulder height (5 percentile): E1 -2+0 cm;

Maximum shoulder height (95 percentile): E2 -0+2 cm;

The mass of the devices described in Figure 2 and Figure 3 of this annex shall be 10 kg +/- 1 kg.



## Annex 4

### Corrosion

1. Test apparatus
  - 1.1. The apparatus shall consist of a mist chamber, a salt solution reservoir, a supply of suitably conditioned compressed air, one or more atomizing nozzles, sample supports, provision for heating the chamber, and necessary means of control. The size and detailed construction of the apparatus shall be optional, provided that the test conditions are met.
  - 1.2. It is important to ensure that drops of solution accumulated on the ceiling or cover of the chamber do not fall on test samples.
  - 1.3. Drops of solution which fall from test samples shall not be returned to the reservoir for respraying.
  - 1.4. The apparatus shall not be constructed of materials that will affect the corrosiveness of the mist.
2. Location of test samples in the mist cabinet
  - 2.1. Samples, except retractors, shall be supported or suspended between 15° and 30° from the vertical and preferably parallel to the principal direction of horizontal flow of mist through the chamber, based upon the dominant surface being tested.
  - 2.2. Retractors shall be supported or suspended so that the axes of the reel for storing the strap shall be perpendicular to the principal direction of horizontal flow of mist through the chamber. The strap opening in the retractor shall also be facing in this principal direction.
  - 2.3. Each sample shall be so placed as to permit free settling of mist on all samples.
  - 2.4. Each sample shall be so placed as to prevent salt solution from one sample dripping on to any other sample.
3. Salt solution
  - 3.1. The salt solution shall be prepared by dissolving  $5 \pm 1$  parts by mass of sodium chloride in 95 parts of distilled water. The salt shall be sodium chloride substantially free of nickel and copper and containing not more than 0.1 per cent of sodium iodide and not more than 0.3 per cent of total impurities in the dry state.

The solution shall be such that, when atomized at 35 °C, the collected solution is in the pH range of 6.5 to 7.2.
4. Compressed air
  - 4.1. The compressed air supply to the nozzle or nozzles for atomizing the salt solution shall be free of oil and dirt, and maintained at a pressure between 70 kN/m<sup>2</sup> and 170 kN/m<sup>2</sup>.
5. Conditions in the mist chamber
  - 5.1. The exposure zone of the mist chamber shall be maintained at 35 °C  $\pm$  5 °C.

At least two clean mist collectors shall be placed within the exposure zone, so that no drops of solution from the test samples or any other sources are collected. The collectors shall be placed near the test samples, one as near as possible to any nozzle and one as far as possible from all nozzles. The mist shall be such that, for each 80 cm<sup>2</sup> of horizontal collecting area, from 1.0 to 2.0 ml of solution per hour, when measured over an average of at least 16 hours, is collected in each collector.
  - 5.2. The nozzle or nozzles shall be directed or baffled, so that the spray does not impinge directly on the test samples.

**Annex 5**

**Overturning – Load Application Device**

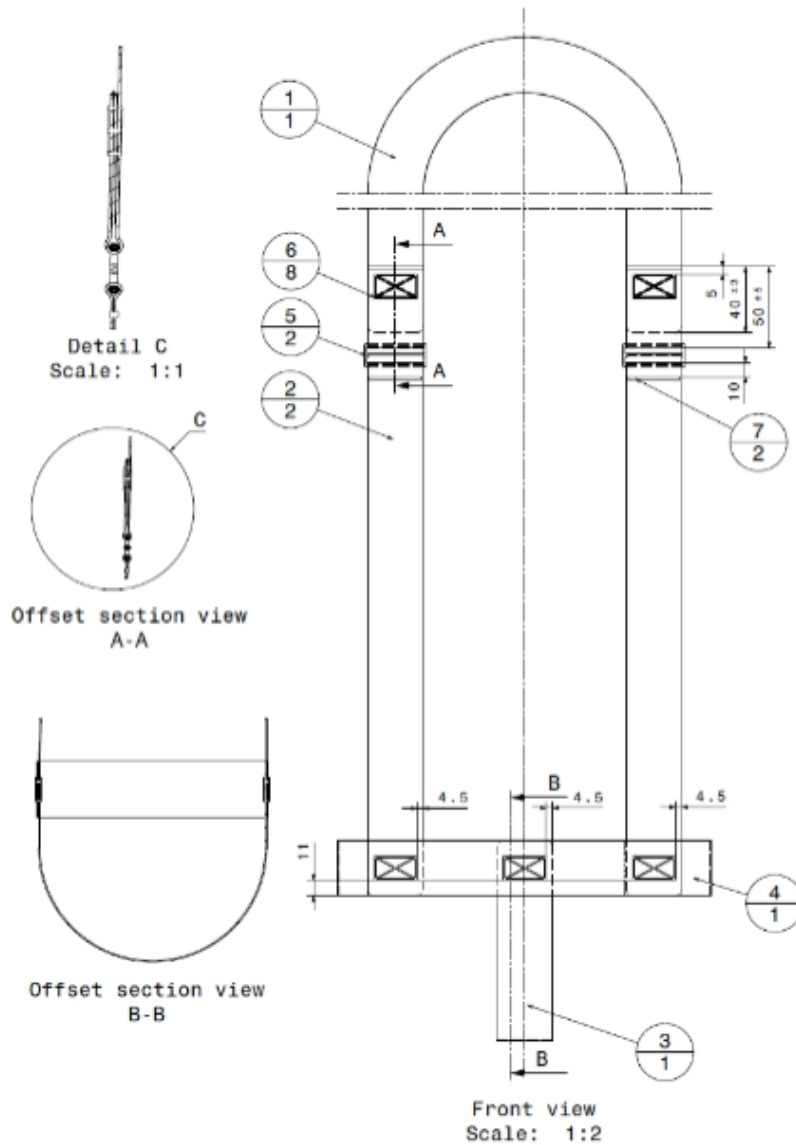

Table 1

No.	Part Number	Name	Information	Quantity
1	PV000009.1	Head belt – 39 mm	-	1
2	PV000009.2	Shoulder belt lh-rh – 39 mm	-	2
3	PV000009.3	Crotch belt – 39 mm	-	1
4	PV000009.4	Hip belt – 39 mm	-	1
5	102 18 31	Stitch pattern (30 x 17)	Stitch: 77, thread: 30, colour. SABA grey	8
6	PV000009.5	Plastic buckle	-	2
7	PV000009.6	Stitch pattern (2 x 37)	Stitch: 77, thread: 30, colour. SABA grey	2

Table 2

Stretch length	( $\pm 5$ mm)					
	Dummy Q0	Q1	Q1.5	Q3	Q6	Q10
Head belt	1,000 mm	1,000 mm	1,000 mm	1,200 mm	1,200 mm	1,200 mm
Shoulder belt	750 mm	850 mm	950 mm	1,000 mm	1,100 mm	1,300 mm
Crotch belt	300 mm	350 mm	400 mm	400 mm	450 mm	570 mm
Hip belt	400 mm	500 mm	550 mm	600 mm	700 mm	800 mm
Dimension X	120 mm	130 mm	140 mm	140 mm	150 mm	160 mm

Table 3

Belt			
Width	Thickness	Expansion	Fastness
39 mm $\pm$ 1 mm	1 mm $\pm$ 0.1 mm	5.5 5.6%	Min. 15,000 N

Table 4

Stitch pattern	Min. required force
12 x 12 mm	3.5 kN
30 x 12 mm	5.3 kN
30 x 17 mm	5.3 kN
30 x 30 mm	7.0 kN

all belt radius = 5 mm

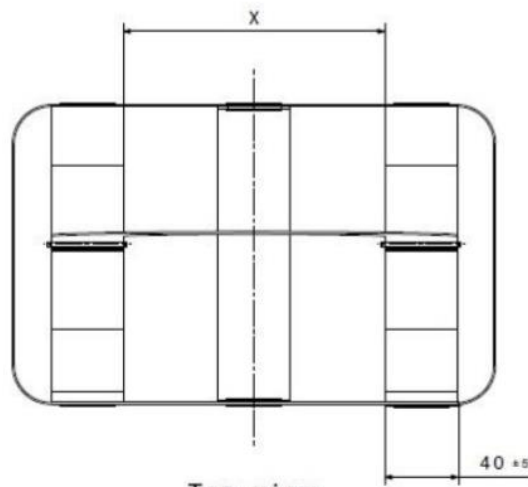

Top view  
Scale:1:2



Isometric view  
Scale:1:10

### Load application device II

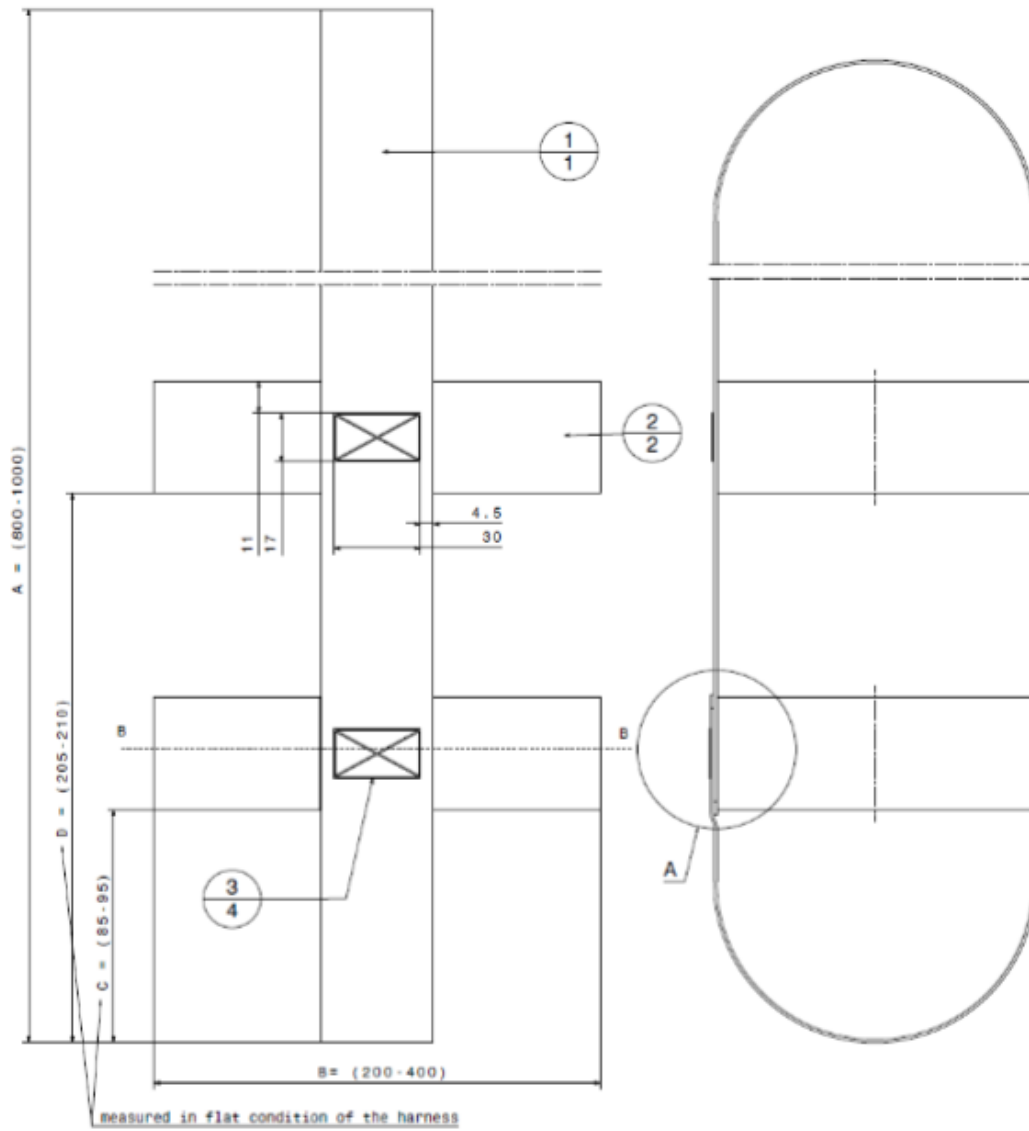

Table 5

No.	Name	Information	Quantity
1	Main belt – 39 mm	-	1
2	Hip belt (upper/lower) – 39 mm	-	2
3	Stich pattern (30 x 17)	Stich 77, thread 30	4

Table 6

Stretch length	(±5 mm)				
	Q0	Q1	Q1.5	Q3	Q6
Main belt (A)	1,740 mm	1,850 mm	1,900 mm	2,000 mm	2,000 mm
Hip belt (B)	530 mm	560 mm	600 mm	630 mm	660 mm
Lower dimension (C)	125 mm	150 mm	150 mm	170 mm	200 mm
Mid dimension (D)	270 mm	300 mm	350 mm	380 mm	380 mm

Table 7

Belt			
Width	Thickness	Expansion	Fastness
39 mm ± 1 mm	1 mm ± 0.1 mm	5.5 – 6.5%	Min. 15,000 N

Table 8

Stich pattern	Min. required force
12 x 12 mm	3.5 kN
30 x 12 mm	5.3 kN
30 x 17 mm	5.3 kN
30 x 30 mm	7.0 kN

All belt radius = 5 mm

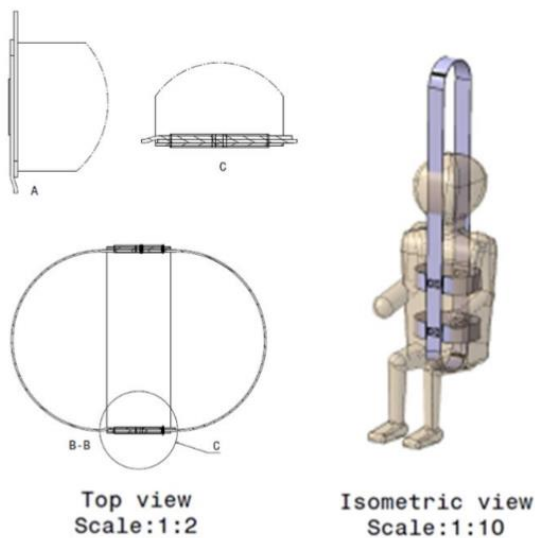

All dimensions in millimetres (mm)

## Annex 6

### Dynamic test

#### Appendix 1 Curve of trolley's deceleration or acceleration, as function of time

In all cases the calibration and measuring procedures shall correspond to those defined in the International Standard ISO 6487; the measuring equipment shall correspond to the specification of a data channel with a channel frequency class (CFC) 60.

Frontal impact – Test pulse 1

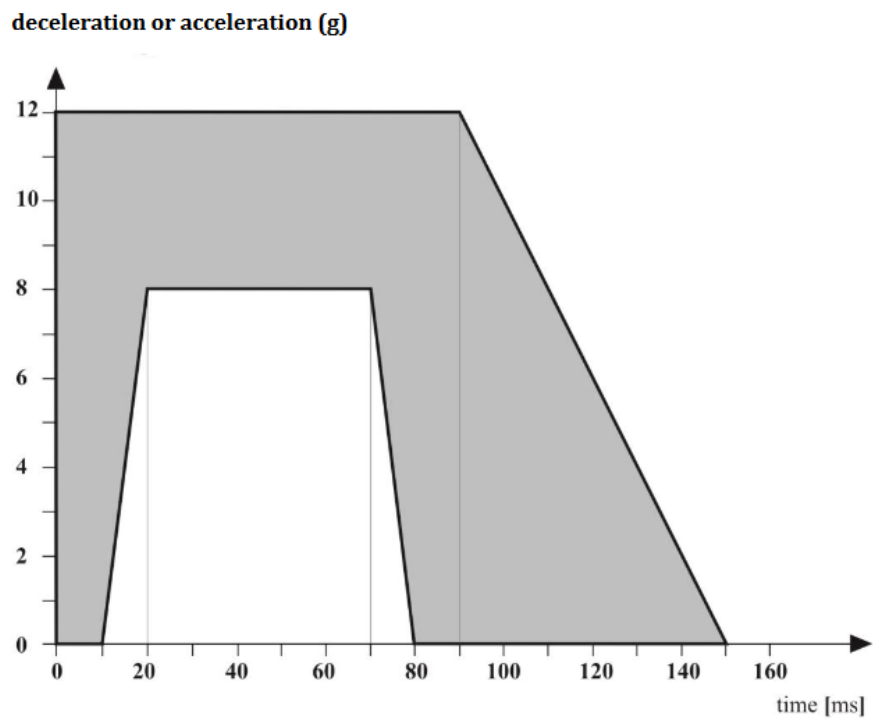

## Appendix 2 Determination of performance criteria

1. Head Performance Criterion (HPC)
  - 1.1. This criterion is considered to be satisfied when, during the test, there is no contact between the head and any vehicle component.
  - 1.2. If that is not the case, a calculation of the value of HPC is made, on the basis of the acceleration (a), by the following expression:

$$\text{HPC} = (t_2 - t_1) \left[ \frac{1}{t_2 - t_1} \int_{t_1}^{t_2} a dt \right]^{2.5}$$

In which:

- 1.2.1 The term "a" is the resultant acceleration is measured in units of gravity, g (1 g = 9,81 m/s<sup>2</sup>);
- 1.2.2. If the beginning of the head contact can be determined satisfactorily, t<sub>1</sub> and t<sub>2</sub> are the two time instants, expressed in seconds, defining an interval between the beginning of the head contact and the end of the recording for which the value of HPC is maximum;
- 1.2.3. If the beginning of the head contact cannot be determined, t<sub>1</sub> and t<sub>2</sub> are the two time instants, expressed in seconds, defining a time interval between the beginning and the end of the recording for which the value of HPC is maximum;
- 1.2.4. Values of HPC for which the time interval (t<sub>1</sub> - t<sub>2</sub>) is greater than 15 ms are ignored for the purposes of calculating the maximum value.
- 1.3. The value of the resultant head acceleration during forward impact which is exceeded for 3 ms cumulatively is calculated from the resultant head acceleration.

Annex 7

Typical buckle strength test device

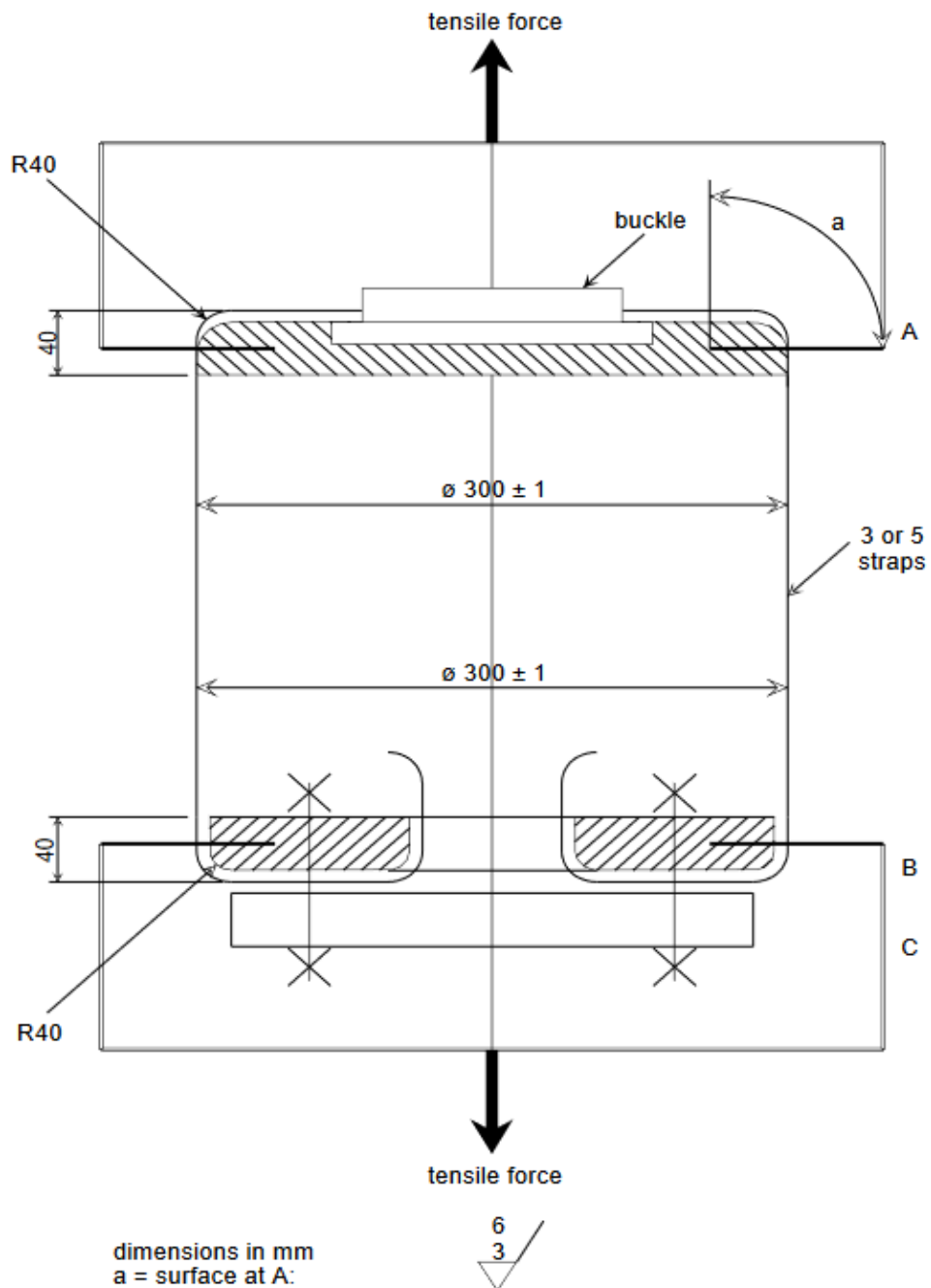



## Annex 8

## Description of conditioning for adjusters

Figure 1  
Conditioning for adjusters mounted directly on the Child Restraint System

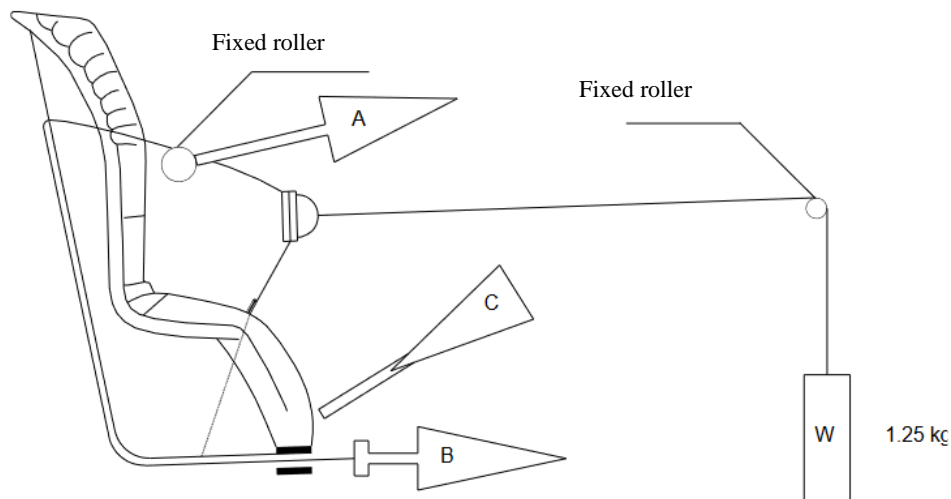

1. Conditioning for adjusters mounted directly on Enhanced Child Restraint Systems (Figure 1)
  - 1.1. Method
    - 1.1.1. With the webbing set at the reference position described in paragraph 8.4.2.8., withdraw at least 50 mm of webbing from the integral harness by pulling on the free end of the webbing.
    - 1.1.2. Attach the adjusted part of the integral harness to the pulling device A.
    - 1.1.3. Activate the adjuster and pull at least 150 mm of webbing into the integral harness. This represents half of one cycle and puts pulling device A to the maximum webbing extraction position.
    - 1.1.4. Connect free end of webbing to pulling device B.
  - 1.2. The procedure of the cycle is:
    - 1.2.1. Pull B at least 150 mm while A exerts no tension on the integral harness.
    - 1.2.2. Activate the adjusters and pull A while B exerts no tension on the free end of the webbing.
    - 1.2.3. At the end of stroke, de-activate the adjuster.
    - 1.2.4. Repeat cycle as specified in paragraph 8.4.2.8. of this Regulation.

Figure 2  
**Conditioning for adjusters connected to a strap (not directly mounted on Child Restraint Systems)**

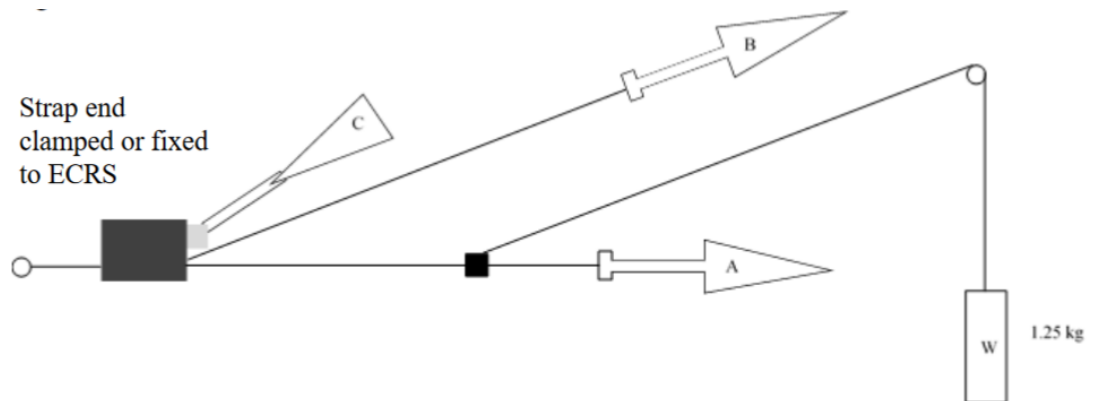

2. Conditioning for adjusters connected to a strap (not directly mounted on Child Restraint Systems) (Figure 2)
  - 2.1. Method
    - 2.1.1. Rigidly clamp the adjuster
    - 2.1.2. With the strap set at the reference position described in paragraph 8.4.2.9., withdraw at least 50 mm of strap from the adjuster by pulling on the free end of the strap.
    - 2.1.3. Attach the adjuster part of the strap to the pulling device A.
    - 2.1.4. Activate the adjuster (C) and pull at least 150 mm of strap through the adjuster. This represents half of one cycle and puts pulling device A to the maximum strap extraction position.
    - 2.1.5. Connect the free end of the strap to pulling device B.
  - 2.2. The cycle is:
    - 2.2.1. Pull B at least 150 mm while A does not exert tension on the strap.
    - 2.2.2. Activate the adjuster (C) and pull A while B does not exert tension on the free end of the strap.
    - 2.2.3. At the end of the stroke, de-activate the adjuster.
    - 2.2.4. Repeat the cycle as specified in paragraph 8.4.2.9. of this Regulation

## Annex 9

## Micro slip

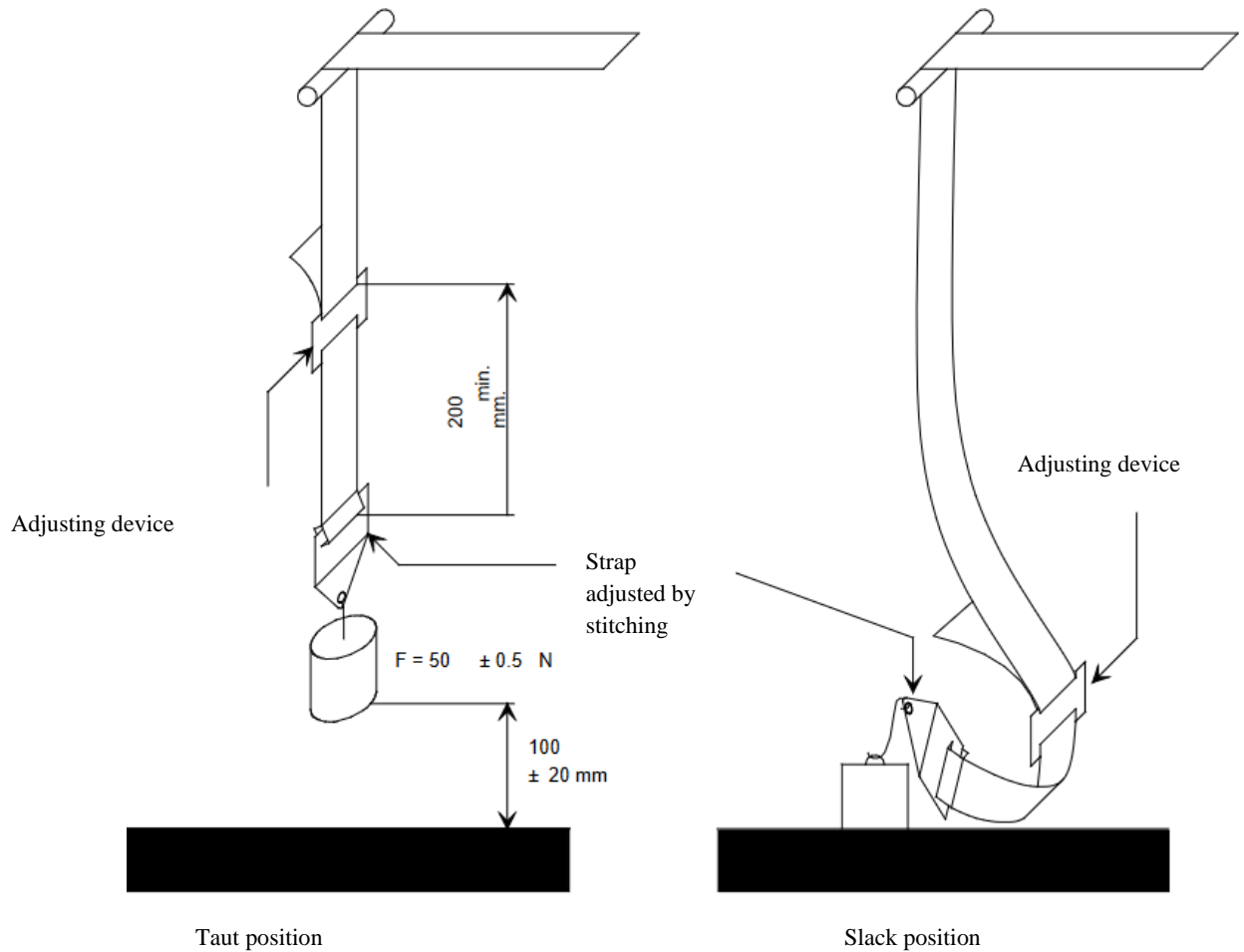
Total travel  $300 \pm 20$  mm

The load of 50 N on the testing device shall be vertically guided in such a way as to prevent load-swing and twisting of the strap.

The attaching device shall be fixed to the load of 50 N in the same manner as in the vehicle.

**Annex 10**

**Abrasion**

Figure 1  
**Procedure type 1**

Example 1

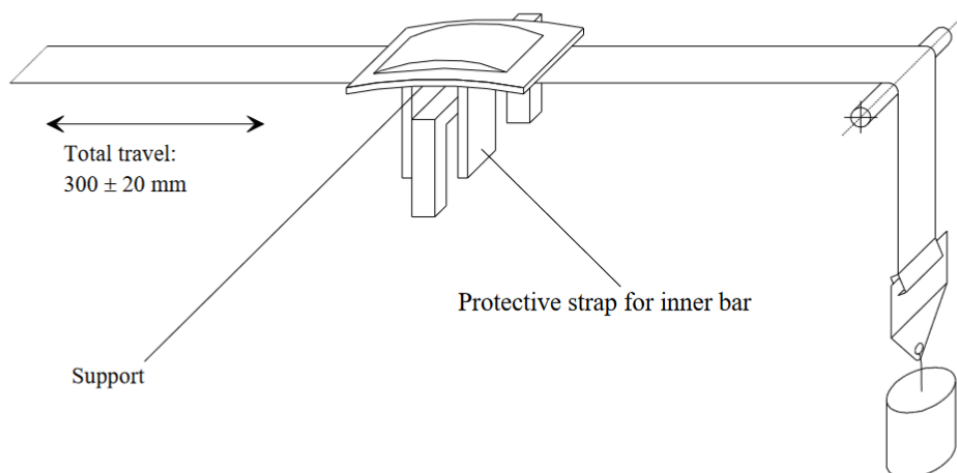

$F = 10 \pm 0.1 \text{ N}$ , can be increased up to maximum  $F = 60 \pm 0.5 \text{ N}$

Example 2

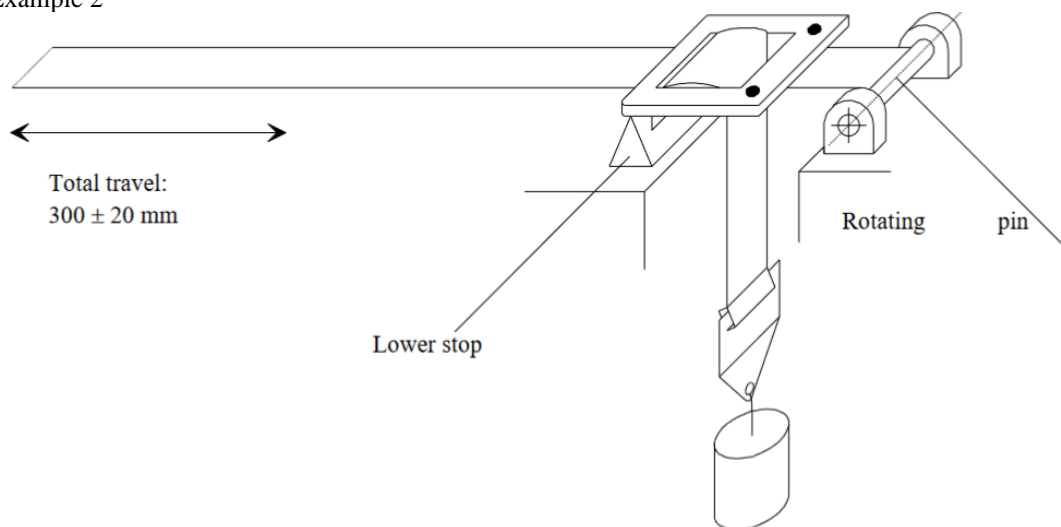

Examples of test arrangements corresponding to the type of adjusting device  $F=10 \pm 0.1 \text{ N}$ , can be increased up to maximum  $F = 60 \pm 0.5 \text{ N}$

Figure 2  
**Procedure type 2**

Example 1

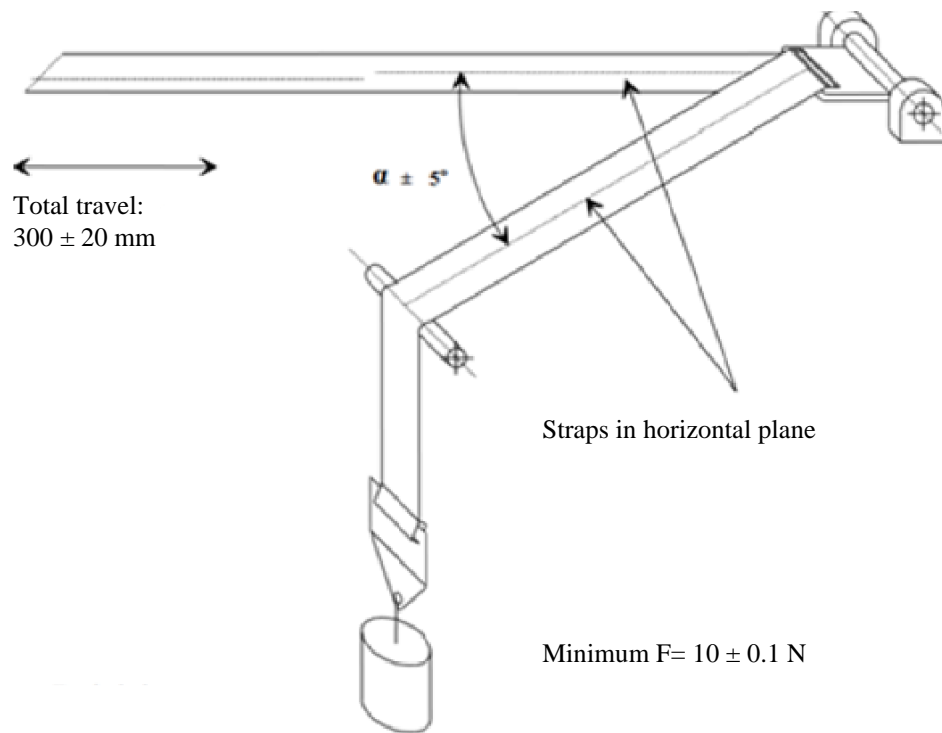

Test in the buckle

Example 2

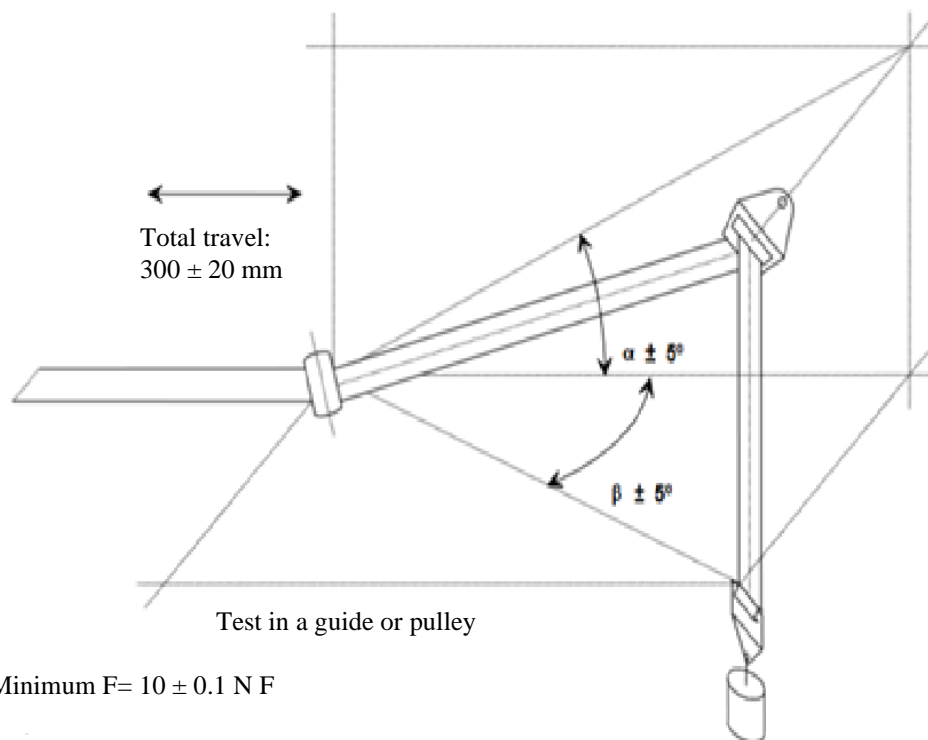

Minimum F= 10 ± 0.1 N F

Where  $\alpha$  and  $\beta$  reproduce the angles as in the real installation (in the three dimensions)

**Annex 11****Minimum list of documents required for approval**

<i>General documents</i>	<i>Application letter/request</i>	<i>4.1.</i>
	Technical description of the Child Restraint System	4.2.1.
	Installation instruction for retractors	4.2.1.
	Declaration on toxicity	
Drawings/ pictures	Exploded view drawing of Child Restraint System and drawings of all its relevant parts	4.2.1. and Annex 1.
	Position of approval mark	4.2.1
	Photographs of Child Restraint System.	4.2.1.
	In case not marked on the sample(s) at the time of submission for approval: Example of orientation, warning labels, size range, occupant mass and additional markings.	5.