

## **Proposal for Amendment 5 of the Mutual Resolution No. 1 (M.R.1) of the 1958 and the 1998 Agreements \***

**Submitted by the expert from the Netherlands**

The text reproduced below was prepared by the expert from the Netherlands to propose a new Addendum 6 on provisions for the specifications and calibration procedure of the 3-D "H"-point machine and the procedure for determining the "H"-point and the actual torso angle for seating positions in motor vehicles, to be used in all referenced UN Regulations and GTRs. The modification to the existing text of the Mutual Resolution No. 1 are marked in bold for new or strikethrough for deleted characters.

This document serves as “information-only” to GRSG; it will be discussed as ECE/TRANS/WP.29/GRSP/2023/37 at the next GRSP session in December 2023.

---

\* In accordance with the programme of work of the Inland Transport Committee for 2023 as outlined in proposed programme budget for 2023 (A/77/6 (Sect. 20), table 20.6), the World Forum will develop, harmonize and update UN Regulations in order to enhance the performance of vehicles. The present document is submitted in conformity with that mandate.

## I. Proposal

*Contents, amend to read:*

### "Contents

	<i>Page</i>
Preamble.....	XX
I. Statement of technical rationale and justification .....	XX
II. Mutual Resolution (M.R.1) of the 1958 and 1998 Agreements concerning the description and performance of test tools and devices necessary for the assessment of compliance of wheeled vehicles, equipment and parts according to the technical prescriptions specified in Regulations and global technical regulations.....	XX
1. Scope .....	XX
2. General provisions .....	XX
3. Specific provisions .....	XX
Appendix.....	XX
Addendum 1 - (Reserved for Bio Rear Impact Dummy (BioRID) specifications) .....	XX
Addendum 2 - Specifications for the Construction, Preparation and Certification of the World Side Impact 50 <sup>th</sup> percentile adult male anthropomorphic test device (WorldSID 50 <sup>th</sup> male) .....	XX
Addendum 3 - Specifications for the Construction, Preparation and Certification of the flexible Pedestrian Legform Impactor (FlexPLI).....	XX
Addendum 4 – (Reserved for Q Dummies) .....	XX
[Addendum 5 – Specifications for the Qualification of Human Body Models for pedestrian HIT determination as a DPPS prerequisite (DPPS HBMs) .....	XX]
Addendum 6 – Specifications and calibration procedure of the 3-D "H"-point machine and the procedure for determining the "H"-point and the actual torso angle for seating positions in motor vehicles .....	XX

### I. Statement of technical rationale and justification

...

### II. Mutual Resolution (M.R.1) of the 1958 and 1998 Agreements concerning the description and performance of test tools and devices necessary for the assessment of compliance of wheeled vehicles, equipment, and parts according to the technical prescriptions specified in Regulations and global technical regulations.

[...]

*Paragraphs 3. and 3.1., Specific provisions, amend to read:*

### 3. Specific provisions

- 3.1. The table below details the individual addenda to this Mutual Resolution in which details of the design, construction, maintenance and preparation of the test devices or equipment can be found.

<i>ECE/TRANS/WP.29/1101</i>	<i>Generic name of the Test Tool</i>	<i>Regulation(s) requiring the test Tool Device</i>	<i>Global technical regulation(s) requiring the Test Tool or Device</i>	<i>Date of adoption of the Addendum</i>
...	(Reserved)	No 17	No 7	...
- Addendum 1 to M.R.1	BioRID Dummy			
Amend.1	WorldSID	No. 135	No. 14	12 Nov. 2014
- Addendum 2 to M.R.1	50 <sup>th</sup> male Dummy			
Amend.2	FlexPLI	No. 127	No. 9	
- Addendum 3 to M.R.1				
Amend.3	(Reserved)	...	...	...
- Addendum 4 to M.R.1	Q Dummy			
<b>[Amend.4</b>	<b>DPPS</b>	<b>No. 127</b>	<b>No. 9</b>	<b>( )</b>
<b>- Addendum 5 to M.R.1</b>	<b>HBM</b>			
Amend.5	3-D "H"-point machine	No's. 14, 16, 17, 21, 25, 32, 33, 35, 43, 46, 80, 94, 95, 114, 125, 135, 137, 166, 167	No's. 6, 7, 14	( )
- Addendum 6 to M.R.1				

"

*Appendix*, amend to read:

"Addendum 1 – (Reserved for Bio Rear Impact Dummy (BioRID) specifications)

Addendum 2 – Specifications for the Construction, Preparation and Certification of the World Side Impact 50th percentile adult male anthropomorphic test device (WorldSID 50th male)

Addendum 3 – Specifications for the Construction, Preparation and Certification of the flexible Pedestrian Legform Impactor (FlexPLI)

Addendum 4 – (Reserved for Q Dummies)

**[Addendum 5 – Specifications for the Qualification of Human Body Models for pedestrian HIT determination as a DPPS prerequisite (DPPS HBMs)]**

**Addendum 6 – Specifications and calibration procedure of the 3-D "H"-point machine and the procedure for determining the "H"-point and the actual torso angle for seating positions in motor vehicles.**

## Contents

	<i>Page</i>
1. Introduction.....	X
2. Requirements .....	X
3. Procedure for "H" point and actual torso angle determination.....	X

### Annexes

A Description of the three-dimensional "H" point machine (3-D "H" point machine).....	XX
B Three-dimensional reference system.....	XX
C Reference data concerning seating positions.....	XX
D 3D "H"-point machine dimensions and tolerances.....	XX

# Specifications and calibration procedure of the 3-D "H"-point machine and the procedure for determining the "H"-point and the actual torso angle for seating positions in motor vehicles.

## 1. Introduction

This Addendum provides the specifications and calibration procedure of the 3-D "H"-point machine and the procedure for determining the "H"-point and the actual torso angle for seating positions in motor vehicles, to be used in all referenced United Nations Regulations and United Nations GTRs.

### 1.1. Limitations

The procedure described in this text is intended solely for the use in combination with testing and certification in accordance with the referenced United Nations Regulations and United Nations GTRs. Use and calibration of the 3-D "H"-point machine for other purposes (e.g. development testing, Consumer Rating Programs) may require a different and/or more accurate measuring tool, procedure and/or calibration tolerances.

### 1.2. Definitions

Throughout this Addendum the following definitions are used:

- 1.2.1. *"Reference data"* means one or several of the following characteristics of a seating position:
  - 1.2.1.1. The "H" point and the "R" point and their relationship;
  - 1.2.1.2. The actual torso angle and the design torso angle and their relationship.
- 1.2.2. *"Three-dimensional H-point machine"* (3-D "H" point machine) means the device used for the determination of "H" points and actual torso angles. This device is described in Annex A to this Addendum and calibrated in accordance with Annex D to this Addendum.
- 1.2.3. *"H" point* means the pivot centre of the torso and thigh of the 3-D "H" point machine installed in the vehicle seat in accordance with the procedure described in paragraph 4. below. The "H" point is located in the centre of the centre line of the device which is between the 'H' point sight buttons on either side of the 3-D "H" point machine. The "H" point corresponds theoretically to the "R" point (for tolerances, see paragraph 2.2.2. below). Once determined in accordance with the procedure described in paragraph 3., the "H" point is considered as fixed in relation to the seat-cushion structure and as moving with it when the seat is adjusted.
- 1.2.4. *"R" point or "seating reference point"* means a design point defined by the vehicle manufacturer for each seating position and established with respect to the three-dimensional reference system.
- 1.2.5. *"Torso line"* means the centre line of the probe of the 3-D "H" point machine with the probe in the fully rearward position.

- 1.2.6. *"Actual torso angle"* means the angle measured between a vertical line through the "H" point and the torso line using the back angle quadrant on the 3-D "H" point machine. The actual torso angle corresponds theoretically to the design torso angle (for tolerances, see paragraph 2.2.2. below).
- 1.2.7. *"Design torso angle"* means the angle measured between a vertical line through the "R" point and the torso line in a position which corresponds to the design position of the seat-back established by the vehicle manufacturer.
- 1.2.8. *"Centre plane of occupant"* (CPO) means the median plane of the 3-D "H" point machine positioned in each designated seating position; it is represented by the co-ordinate of the "H" point on the "Y" axis. For individual seats, the centre plane of the seat coincides with the centre plane of the occupant. For other seats, the centre plane of the occupant is specified by the manufacturer.
- 1.2.9. *"Three-dimensional reference system"* means a system as described in Annex B to this Addendum.
- 1.2.10. *"Fiducial marks"* are physical points (holes, surfaces, marks or indentations) on the vehicle body as defined by the manufacturer;
- 1.2.11. *"Vehicle measuring attitude"* means the position of the vehicle as defined by the co-ordinates of fiducial marks in the three-dimensional reference system.

## **2. Requirements**

### **2.1. Data presentation**

For each seating position where reference data are required in order to demonstrate compliance with the provisions of the corresponding UN Regulation and/or GTR, all or an appropriate selection of the following data shall be presented in the form indicated in Annex C to this Addendum:

- 2.1.1. The co-ordinates of the "R" point relative to the three-dimensional reference system;
- 2.1.2. The design torso angle;
- 2.1.3. All indications necessary to adjust the seat (if it is adjustable) to the measuring position set out in paragraph 3.3. below.

### **2.2. Relationship between measured data and design specifications**

- 2.2.1. The coordinates of the "H" point and the value of the actual torso angle obtained by the procedure set out in paragraph 3. below shall be compared, respectively, with the coordinates of the "R" point and the value of the design torso angle indicated by the vehicle manufacturer.
- 2.2.2. The relative positions of the "R" point and the "H" point and the relationship between the design torso angle and the actual torso angle shall be considered satisfactory for the seating position in question if the "H" point, as defined by its coordinates, lies within a square of 50 mm side length with horizontal and vertical sides whose diagonals intersect at the "R" point, and if the actual torso angle is within 5° of the design torso angle.

- 2.2.3. If these conditions are met, the "R" point and the design torso angle shall be used to demonstrate compliance with the provisions of the corresponding United Nations Regulation and/or United Nations GTR;
- 2.2.4. If the "H" point or the actual torso angle does not satisfy the requirements of paragraph 2.2.2. above, the "H" point and the actual torso angle shall be determined twice more (three times in all). If the results of two of these three operations satisfy the requirements, the conditions of paragraph 2.2.3. above shall apply;
- 2.2.5. If the results of at least two of the three operations described in paragraph 2.2.4. above do not satisfy the requirements of paragraph 2.2.2. above, or if the verification cannot take place because the vehicle manufacturer has failed to supply information regarding the position of the "R" point or regarding the design torso angle, the centroid of the three measured points or the average of the three measured angles shall be used and be regarded as applicable in all cases where the "R" point or the design torso angle is referred to in the corresponding United Nations Regulation and/or United Nations GTR.

### **3. Procedure for "H" point and actual torso angle determination**

- 3.1. The vehicle shall be preconditioned, at the manufacturer's discretion, at a temperature of  $20\text{ }^{\circ}\text{C} + 10\text{ }^{\circ}\text{C}$  to ensure that the seat material reaches room temperature. If the seat to be checked has never been sat upon, a 70 to 80 kg person or device shall sit on the seat twice for one minute to flex the cushion and back. At the manufacturer's request, all seat assemblies shall remain unloaded for a minimum period of 30 minutes prior to installation of the 3-D "H" point machine.
- 3.2. The vehicle shall be in the measuring attitude defined in paragraph 1.2.11. above.
- 3.3. The seat, if it is adjustable, shall be adjusted first to the rearmost normal driving or riding position, as indicated by the vehicle manufacturer, taking into consideration only the longitudinal adjustment of the seat, excluding seat travel used for purposes other than normal driving or riding positions. Where other modes of seat adjustment exist (vertical, angular, seat-back, etc.), these will then be adjusted to the position specified by the vehicle manufacturer. For suspension seats, the vertical position shall be rigidly fixed corresponding to a normal driving position as specified by the manufacturer.
- 3.4. The area of the seating position taken up by the 3-D "H" point machine shall be covered by a muslin cotton, of sufficient size and appropriate texture, described as a plain cotton fabric having 18.9 threads per  $\text{cm}^2$  and weighing  $0.228\text{ kg/m}^2$ , or knitted or non-woven fabric having equivalent characteristics.

If the test is performed on a seat outside the vehicle, the floor on which the seat is placed shall have the same essential characteristics as the floor of the vehicle in which the seat is intended to be used.

- 3.5. Place the seat and back assembly of the 3-D "H" point machine so that the centre plane of the occupant (CPO) coincides with the centre plane of the 3-D "H" point machine. At the manufacturer's request, the 3-D "H" point machine may be moved inboard with respect to the CPO if the 3-D "H" point machine is located so far outboard that the seat edge will not permit levelling of the 3-D "H" point machine.
- 3.6. Adjust the lower leg and thigh segments to the setting corresponding to 50 percentile, which corresponds to 417 mm for the lower leg segment and 432 mm for the thigh. On request of the manufacturer, the lower leg and thigh setting at which the H-point is measured may deviate from this. This shall be clearly indicated in the H-point and/or "R" point drawing(s).
- 3.7. Attach the foot and lower leg assemblies to the seat-pan assembly, either individually or by using the T-bar and lower leg assembly. The line through the "H" point sight buttons shall be parallel to the ground and perpendicular to the longitudinal centre plane of the seat.
- 3.8. Adjust the feet and leg positions of the 3-D "H" point machine as follows:
- 3.8.1. Designated seating position: driver and outside front passenger
- 3.8.1.1. Both feet and leg assemblies shall be moved forward in such a way that the feet take up natural positions on the floor, between the operating pedals if necessary. Where possible the left foot shall be located at approximately the same distance to the left of the centre plane of the 3-D "H" point machine as the right foot is to the right. The spirit level verifying the transverse orientation of the 3-D "H" point machine is brought to the horizontal by readjustment of the seat pan if necessary, or by adjusting the leg and foot assemblies towards the rear. The line passing through the "H" point sight buttons shall be maintained perpendicular to the longitudinal centre plane of the seat.
- 3.8.1.2. If the left leg cannot be kept parallel to the right leg and the left foot cannot be supported by the structure, move the left foot until it is supported. The alignment of the sight buttons shall be maintained.
- 3.8.2. Designated seating position: outboard rear seat
- For rear seats or auxiliary seats, the legs are located as specified by the manufacturer. If the feet then rest on parts of the floor which are at different levels, the foot which first comes into contact with the front seat shall serve as a reference and the other foot shall be so arranged that the spirit level giving the transverse orientation of the seat of the device indicates the horizontal.
- 3.8.3. Other designated seating positions:
- The general procedure indicated in paragraph 3.8.1. above shall be followed, except that the feet shall be placed as specified by the vehicle manufacturer.
- 3.9. Apply lower leg and thigh weights and level the 3-D "H" point machine.
- 3.10. Tilt the back pan forward against the forward stop and draw the 3-D "H" point machine away from the seat-back using the T-bar. Reposition the 3-D "H" point machine on the seat by one of the following methods:



- 3.10.1. If the 3-D "H" point machine tends to slide rearward, use the following procedure. Allow the 3-D "H" point machine to slide rearward until a forward horizontal restraining load on the T-bar is no longer required, i.e. until the seat pan contacts the seat-back. If necessary, reposition the lower leg.
- 3.10.2. If the 3-D "H" point machine does not tend to slide rearward, use the following procedure. Slide the 3-D "H" point machine rearward by applying a horizontal rearward load to the T-bar until the seat pan contacts the seat-back (see Figure A.2 of Annex A to this Addendum).
- 3.11. Apply a  $100 \pm 10$  N load to the back and pan assembly of the 3-D "H" point machine at the intersection of the hip angle quadrant and the T-bar housing. The direction of load application shall be maintained along a line passing through the above intersection to a point just above the thigh bar housing (see Figure A.2 of Annex A to this Addendum). Then carefully return the back pan to the seat-back. Care shall be exercised throughout the remainder of the procedure to prevent the 3-D "H" point machine from sliding forward.
- 3.12. Install the right and left buttock weights and then, alternately, the eight torso weights. Maintain the 3-D "H" point machine level.
- 3.13. Tilt the back pan forward to release the tension on the seat-back. Rock the 3-D "H" point machine from side to side through a  $10^\circ$  arc ( $5^\circ$  to each side of the vertical centre plane) for three complete cycles to release any accumulated friction between the 3-D "H" point machine and the seat.

During the rocking action, the T-bar of the 3-D "H" point machine may tend to diverge from the specified horizontal and vertical alignment. The T-bar shall therefore be restrained by applying an appropriate lateral load during the rocking motions. Care shall be exercised in holding the T-bar and rocking the 3-D "H" point machine to ensure that no inadvertent exterior loads are applied in a vertical or fore and aft direction.

The feet of the 3-D "H" point machine are not to be restrained or held during this step. If the feet change position, they should then be allowed to remain in that attitude for the moment.

Carefully return the back pan to the seat-back and check the two spirit levels for zero position. If any movement of the feet has occurred during the rocking operation of the 3-D "H" point machine, they shall be repositioned as follows:

Alternately, lift each foot off the floor the minimum necessary amount until no additional foot movement is obtained. During this lifting, the feet are to be free to rotate; no forward or lateral loads are to be applied. When each foot is placed back in the down position, the heel is to be in contact with the structure designed for this.

Check the lateral spirit level for zero position; if necessary, apply a lateral load to the top of the back pan sufficient to level the 3-D "H" point machine's seat pan on the seat.

- 3.14. Holding the T-bar to prevent the 3-D "H" point machine from sliding forward on the seat cushion, proceed as follows:**
- (a) Return the back pan to the seat-back,**
  - (b) Alternately apply and release a horizontal rearward load, not to exceed 25 N, to the back angle bar at a height approximately at the centre of the torso weights until the hip angle quadrant indicates that a stable position has been reached after load release. Care should be taken to ensure that no exterior downward or lateral loads are applied to the 3-D "H" point machine. If another level adjustment of the 3-D "H" point machine is necessary, rotate the back pan forward, re-level, and repeat the procedure from paragraph 3.13.**
- 3.15. Take all measurements:**
- 3.15.1. The coordinates of the "H" point are measured with respect to the three-dimensional reference system.**
  - 3.15.2. The actual torso angle is read at the back angle quadrant of the 3-D "H" point machine with the probe in its fully rearward position.**
- 3.16. If a rerun of the installation of the 3-D "H" point machine is desired, the seat assembly shall remain unloaded for a minimum period of 30 minutes prior to the re-run. The 3-D "H" point machine shall not be left loaded on the seat assembly longer than the time required to perform the test.**
- 3.17. If the seats in the same row can be regarded as similar (bench seat, identical seats, etc.) only one "H" point and one actual torso angle may be determined for each row of seats, the 3-D "H" point machine described in the Annex A to this Addendum being seated in a place regarded as representative for the row.**
- This place shall be:**
- 3.17.1. In the case of the front row, the driver's seat.**
  - 3.17.2. In the case of the rear row or rows, an outer seat.**

## Annex A

### Description of the three-dimensional "H" point machine (3-D "H" point machine)

1. The machine shall correspond to that described in SAE J826-Nov. 2008 from the Society of Automotive Engineers (SAE), 400 Commonwealth Drive, Warrendale, Pennsylvania 15096, United States of America. It may (in addition) comply with a later version of this SAE J826 standard as long as it also/still complies with the November 2008 version.
2. **Back and seat pans**  
The back and seat pans are constructed of reinforced plastic and metal; they simulate the human torso and thigh and are mechanically hinged at the "H" point. A quadrant is fastened to the probe hinged at the "H" point to measure the actual torso angle. An adjustable thigh bar, attached to the seat pan, establishes the thigh centre line and serves as a baseline for the hip angle quadrant.
3. **Body and leg elements**  
Lower leg segments are connected to the seat pan assembly at the T-bar joining the knees, which is a lateral extension of the adjustable thigh bar. Quadrants are incorporated in the lower leg segments to measure knee angles. Shoe and foot assemblies are calibrated to measure the foot angle. Two spirit levels orient the device in space. Body element weights are placed at the corresponding-centres of gravity to provide seat penetration equivalent to a 76 kg male. All joints of the 3-D "H" point machine should be checked for free movement without encountering any noticeable friction.

Figure A.1  
3-D "H" point machine elements designation

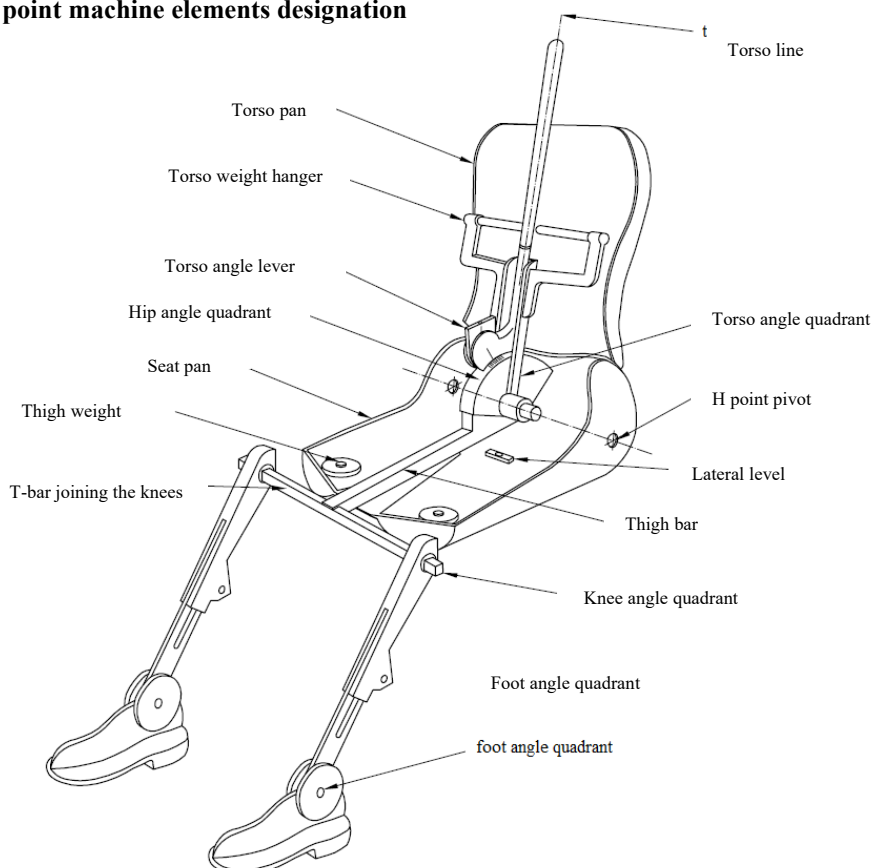

**Figure A.2**  
**Dimensions of the 3-D H- machine elements and load distribution**

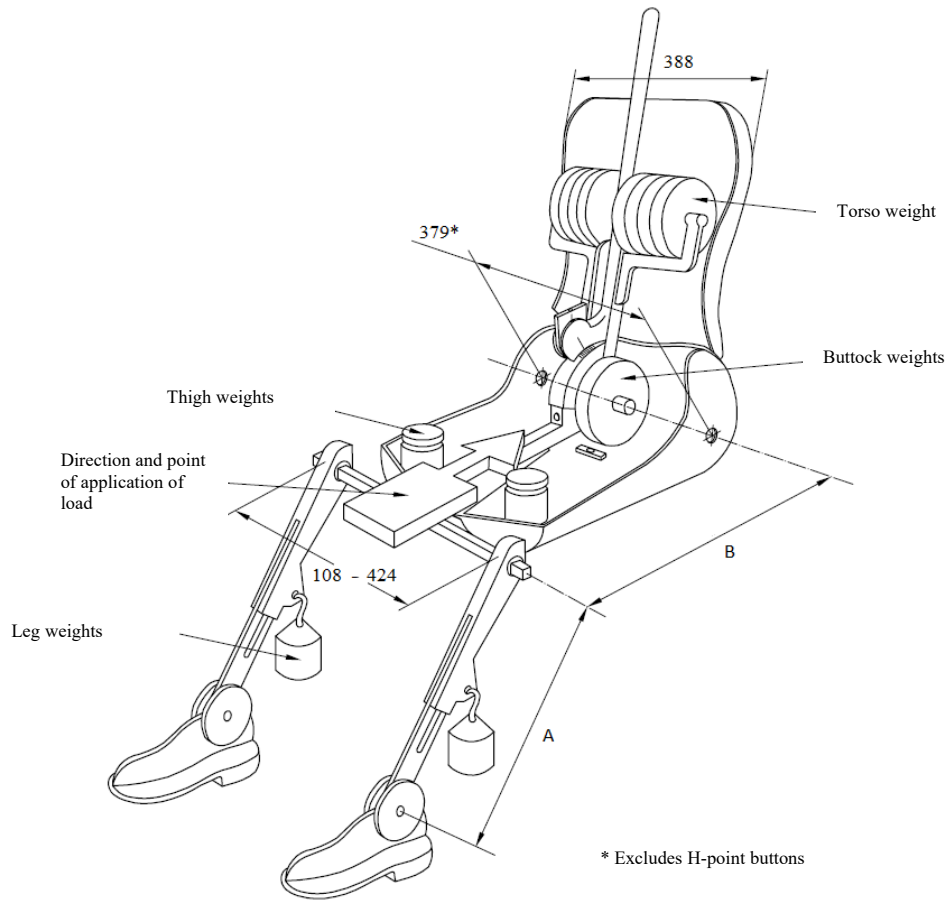

	<b>10th Percentile (mm)</b>	<b>50th Percentile (mm)</b>	<b>95th Percentile (mm)</b>
<b>Lower leg segment (A)</b>	<b>392.7</b>	<b>417.1</b>	<b>458.7</b>
<b>Thigh segment (B)</b>	<b>407.7</b>	<b>431.5</b>	<b>455.7</b>

## Annex B

### Three-dimensional reference system

1. The three-dimensional reference system is defined by three orthogonal planes established by the vehicle manufacturer (see Figure).<sup>1</sup>
2. The vehicle measuring attitude is determined by positioning the vehicle on a supporting surface such that the co-ordinates of the fiducial marks correspond to the values indicated by the manufacturer.
3. The coordinates of the "R" point and the "H" point are established in relation to the fiducial marks defined by the vehicle manufacturer.

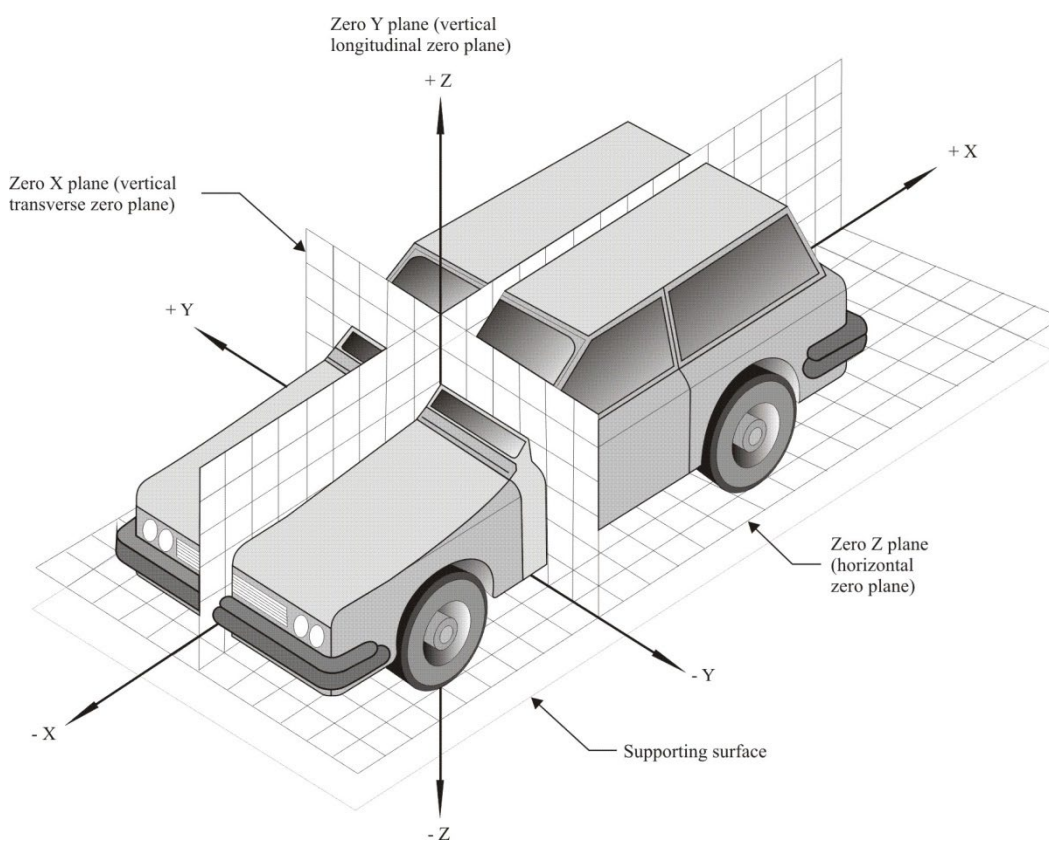

<sup>1</sup> The reference system corresponds to ISO Standard 4130:1978

## Annex C

### Reference data concerning seating positions

1. **Coding of reference data**  
 Reference data are listed consecutively for each seating position. Seating positions are identified by a two-digit code. The first character is an Arabic numeral and designates the row of seats, counting from the front to the rear of the vehicle. The second digit is a capital letter which designates the location of the seating position in a row, as viewed in the direction of forward motion of the vehicle; the following letters shall be used:  
 L = left,  
 C = centre,  
 R = right.
2. **Description of vehicle measuring attitude**
  - 2.1. **Coordinates of fiducial marks**  
 X .....  
 Y .....  
 Z .....
3. **List of reference data**
  - 3.1. **Seating position: .....**
    - 3.1.1. **Coordinates of the "R" point:**  
 X .....  
 Y .....  
 Z .....
    - 3.1.2. **Design torso angle: .....**
    - 3.1.3. **Specifications for seat adjustment:<sup>2</sup>**  
 Horizontal: .....  
 Vertical: .....  
 Angular: .....  
 Torso angle: .....
4. **Setting of the lower legs and thighs of the 3D "H" point machine: .....**  
 Lower leg: .....  
 Thigh: .....

*Note:* List reference data for further seating positions under paragraphs 3.2., 3.3., etc.

<sup>2</sup> Strike out what does not apply.

## Annex D

## 3D "H"-point machine dimensions and tolerances

<i>3D "H" Point Machine</i>			
.....			Date .....
Item	Description	Specification	Measurement
<b>Back Pan and Cushion Pan</b>			
1	H-point joint torque	3.4 ± 0.45 Nm	
2a	H1L divot rearward to vertical angle block surface	134.9 ± 2 mm	
2b	H1R divot rearward to vertical angle block surface	134.9 ± 2 mm	
2c	Mean H-point (centre) rearward to vertical angle block surface	134.9 ± 2 mm	
3a	H1L divot height from level surface	97.6 ± 2 mm	
3b	H1R divot height from level surface	97.6 ± 2 mm	
Shim under cushion pan until 3a=3b			
3c	H1 divot height from level surface (mean of 3a and 3b)	97.6 ± 2 mm	
3d	Cushion pan bubble level	bubble reads level	
4a (b)	Left (Right) knee pivot to H1L (H1R), x – horizontal distance for 95% leg length	455.7 ± 2 mm	Left    Right
4c (d)	Left (Right) knee pivot height from level surface, z – 95% leg	97.6 ± 2 mm	
4e (f)	Left (Right) knee pivot to H1L (H1R), x - 50% leg	431.5 ± 2 mm	
4g (h)	Left (Right) knee pivot to H1L (H1R), x - 10% leg	407.7 ± 2 mm	
4i	Knee pivot x-distance from H-point (mean of 4a and 4b)	455.7 ± 2 mm	
4j	Knee pivot height from level surface (mean of 4c and 4d)	97.6 ± 2 mm	
4k	Difference in height between mean H1 and knee pivot (4j-3c)	0 ± 1 mm	
4m	x-axis side view angle [arctan(4k/4i)]	0 ± 0.2°	
5a	Back pan to cushion pan offset (value is		Initial    Final

<i>3D "H" Point Machine</i>		<i>Date .....</i>
	.....	.....
	positive if back pan is forward of cushion pan); measure to middle bolts of lower back at C/L	0 +4/-0 mm
5b	Flat surface on lower mid-back; measure offset difference between upper and lower bolts at lower back C/L	< 1.1 mm (90 ± 0.5°)
	<i>Note: After adjusting cushion pan bubble level or back pan offset/verticality, re-establish the measurement coordinate system. Retake measurements 2-5.</i>	
6a	Thigh angle land (inclinometer on T-bar housing)	0 ± 0.1°
6b	Thigh angle (from CMM points on land)	0 ± 0.2°
7a	Torso angle land (inclinometer on head room probe scale)	90 ± 0.1°
7b	Torso angle (from CMM points on land)	90 ± 0.2°
7c	Hip angle (from CMM points on torso and thigh angle lands) Hip angle = torso angle – thigh angle	90 ± 0.25°
7d	Hip angle scale reading	90 ± 1°
7e	Torso angle bubble level on hip quadrant	bubble reads level
7f	Torso (back) angle scale reading (forward is a negative angle)	0 ± 1°
7g	Torso angle (inclinometer on land--left side torso weight yoke)	90 ± 0.5°
7h	Torso angle (from CMM points on land--left torso weight yoke)	90 ± 0.5°
8a <sup>1</sup>	Mean H-pt to left inboard centre of torso weight bar, Z  Note: Measurements 8a-d are made at 25 mm from inboard end of torso weight bar. Use CMM circle method to find centre.	356.4 ± 1 mm
8b <sup>1</sup>	Mean H-pt to left inboard centre of torso weight bar, X	0 ± 1 mm
8c <sup>1</sup>	Mean H-pt to right inboard centre of torso weight bar, Z	356.4 ± 1 mm
8d <sup>1</sup>	Mean H-pt to right inboard centre of torso weight bar, X	0 ± 1 mm
9	Lateral bubble level inclinometer reading	0 ± 1°
10a <sup>2</sup>	Cushion pan width at H-point (3.8 mm button depth not included)	379 ± 2 mm
10b <sup>2</sup>	Back pan width, maximum	388 ± 2



<i>3D "H" Point Machine</i>		<i>Date .....</i>
.....		.....
<b>mm</b>		
<b>Head Room</b>		
11a	Head room probe height at 39 inch setting above surface plate at H-point (subtract 97.6 if measured from H-point)	986.2 ± 2 mm (888.6 mm from H-point)
11b	Tip of head room probe fore aft of H-point	± 5 mm
11c	Tip of head room probe each side of H-point	± 5 mm
<b>Lower Legs</b>		
		<b>Left    Right</b>
12a (c)	Left (Right) knee angle scale – inboard (I) and outboard (O) sides (back of leg set at 90 degrees and T-bar horizontal)	I O
		90 ± 1°
		I
12b (d)	Ankle (foot) angle scale	O
		96.5 ± 1°
13a (e)	Left (Right) ankle pivot to level surface	107.2 ± 2 mm
13b (f)	Left (Right) knee pivot to ankle pivot (95%)	458.7 ± 2 mm
13c (g)	Left (Right) knee pivot to ankle pivot (50%)	417.1 ± 2 mm
13d (h)	Left (Right) knee pivot to ankle pivot (10%)	392.7 ± 2 mm
14a	Left (Right) ankle pivot rotates freely	Yes If No, repair.
14b	Left (Right) knee pivot rotates freely	Yes If No, repair.
<b>Machine Weights</b>		
15a	Cushion and Back Pans (includes inclinometer but no weights)	19.7 ± 1.2 kg
15b	Lower leg and shoe * 2	8.8 ± 0.2 kg
15c	Torso and buttock weight * 10, Thigh weight * 2, Leg weight * 2	48.5 ± 0.3 kg
15d	Total weight	77.0 ± 1.5 kg