

17 August 2023

Agreement

Concerning the Adoption of Harmonized Technical United Nations Regulations for Wheeled Vehicles, Equipment and Parts which can be Fitted and/or be Used on Wheeled Vehicles and the Conditions for Reciprocal Recognition of Approvals Granted on the Basis of these United Nations Regulations*

(Revision 3, including the amendments which entered into force on 14 September 2017)

Addendum 16: UN Regulation No. 17

Revision 7

Incorporating all valid text up to:

Supplement 1 to the 09 series of amendments – Date of entry into force: 11 January 2020

10 series of amendments – Date of entry into force: 9 June 2021

Uniform provisions concerning the approval of vehicles with regard to the seats, their anchorages and any head restraints

This document is meant purely as documentation tool. The authentic and legal binding text is:

- ECE/TRANS/WP.29/2019/35

- ECE/TRANS/WP.29/2020/106



UNITED NATIONS

* Former titles of the Agreement:

Agreement Concerning the Adoption of Uniform Conditions of Approval and Reciprocal Recognition of Approval for Motor Vehicle Equipment and Parts, done at Geneva on 20 March 1958 (original version);

Agreement concerning the Adoption of Uniform Technical Prescriptions for Wheeled Vehicles, Equipment and Parts which can be Fitted and/or be Used on Wheeled Vehicles and the Conditions for Reciprocal Recognition of Approvals Granted on the Basis of these Prescriptions, done at Geneva on 5 October 1995 (Revision 2).

UN Regulation No. 17

Uniform provisions concerning the approval of vehicles with regard to the seats, their anchorages and any head restraints

Contents

	<i>Page</i>
Regulation	
1. Scope	5
2. Definitions	5
3. Application for approval	8
4. Approval	9
5. Requirements	10
6. Tests	18
7. Conformity of production	21
8. Penalties for non-conformity of production	21
9. Modifications of the vehicle type and extension of approval with respect to the seats, their anchorages and/or their head restraints	22
10. Production definitively discontinued	22
11. Instruction for use	22
12. Names and addresses of Technical Services responsible for conducting approval tests, and of Type Approval Authorities	22
13. Transitional provisions	23
Annexes	
1 Communication	25
2 Arrangements of the Approval Mark	27
3 Procedure for determining the "H" point and the actual torso angle for seating positions in motor vehicle	29
Appendix 1 - Description of the three-dimensional "H" point machine	29
Appendix 2 - Three-dimensional reference system	29
Appendix 3 - Reference data concerning seating positions	29
4 Minimum Width Measurement Test Procedure	30
5 Displacement and Strength Test Procedure.....	31
6 Test procedure for checking energy dissipation	33
7 Method for testing the strength of seat anchorages and their adjustment, locking and displacement systems	35
8 Gap Measurement Test Procedure	36
9 Test procedure for devices intended to protect the occupants against displacement of luggage	40
Appendix - Corridor of sled's deceleration or acceleration as a function of time (Simulation of frontal impact).....	43
10 Height Measurement Test Procedure	44

11	Backset Measurement Test Procedure.....	50
12	Energy Absorption Test Procedure for Head Restraint from the Front	51
13	Height Retention Test Procedure	53
14	Dynamic Performance Test Procedure	55
15	Non-Use Position Test Procedure	65

1. Scope

This Regulation applies to:

- (a) Vehicles of categories M₁ and N₁ with regard to the strength of seats and their anchorages and with regard to their head restraints;
- (b) Vehicles of categories M₂ and M₃¹ with regard to seats not covered by Regulation No. 80, in respect of the strength of seats and their anchorages, and in respect of their head restraints;
- (c) Vehicles of category M₁ with regard to the design of the rear parts of seat backs and the design of devices intended to protect the occupants from the danger resulting from the displacement of luggage in a frontal impact.

It does not apply to vehicles with regard to side-facing or rearward-facing seats, or to any head restraint fitted to these seats, with the exception vehicles of category M₂ and M₃ of classes A and I, subject to the provisions of paragraph 5.1.1.

2. Definitions

For the purposes of this Regulation,

- 2.1. "*Approval of a vehicle*" means the approval of a vehicle type with regard to the strength of the seats and their anchorages, the design of the rear parts of the seat-backs and the characteristics of their head restraints;
- 2.2. "*Vehicle type*" means a category of motor vehicles which do not differ in such essential respects as:
 - 2.2.1. The structure, shape, dimensions, materials and the mass of the seats, although the seats may differ in covering and colour; differences not exceeding 5 per cent in the mass of the approved seat type shall not be considered significant;
 - 2.2.2. The type and dimensions of the adjustment, displacement and locking systems of the seat-back and seats and their parts;
 - 2.2.3. The type and dimensions of the seat anchorages;
 - 2.2.4. The dimensions, frame, materials and padding of head restraints, although they may differ in colour and covering;
 - 2.2.5. The type and dimensions of the attachments of the head restraint and the characteristics of the part of the vehicle to which the head restraint is attached, in the case of a separate head restraint;
- 2.3. "*Seat*" means a structure which may or may not be integral with the vehicle structure complete with trim, intended to seat one person. Depending on its orientation, a seat is defined as follows:
 - 2.3.1. "*Forward-facing seat*" means a seat which can be used whilst the vehicle is in motion and which faces towards the front of the vehicle in such a manner that the vertical plane of symmetry of the seat forms an angle of less than + 10° or - 10° with the vertical plane of symmetry of the vehicle;
 - 2.3.2. "*Rearward-facing seat*" means a seat which can be used whilst the vehicle is in motion and which faces towards the rear of the vehicle in such a manner that

¹ As defined in the Consolidated Resolution on the Construction of Vehicles (R.E.3.), document ECE/TRANS/WP.29/78/Rev.6, para. 2 - <https://unece.org/transport/standards/transport/vehicle-regulations-wp29/resolutions>

- the vertical plane of symmetry of the seat forms an angle of less than + 10° or - 10° with the vertical plane of symmetry of the vehicle;
- 2.3.3. "*Side-facing seat*" means a seat which can be used whilst the vehicle is in motion and which faces towards the side of the vehicle in such a manner that the vertical plane of symmetry of the seat forms an angle of 90° ($\pm 10^\circ$) with the vertical plane of symmetry of the vehicle;
- 2.4. "*Bench seat*" means a structure complete with trim, intended to seat more than one adult person;
- 2.5. "*Anchorage*" means the system by which the seat assembly is secured to the vehicle structure, including the affected parts of the vehicle structure;
- 2.6. "*Adjustment system*" means the device by which the seat or its parts can be adjusted to a position suited to the morphology of the seated occupant. This device may, in particular, permit:
- 2.6.1. Longitudinal displacement;
- 2.6.2. Vertical displacement;
- 2.6.3. Angular displacement;
- 2.7. "*Displacement system*" means a device by which the seat or one of its parts can be displaced and/or rotated, without a fixed intermediate position, to permit easy access of occupants to the space behind the seat concerned;
- 2.8. "*Locking system*" means a device ensuring that the seat and its parts are maintained in the position of use;
- 2.9. "*Folding seat*" means a seat, which is normally folded, can be easily operated and is designed for occasional use by an occupant;
- 2.10. "*Transverse plane*" means a vertical plane perpendicular to the median longitudinal plane of the vehicle;
- 2.11. "*Longitudinal plane*" means a plane parallel to the median longitudinal plane of the vehicle;
- 2.12. "*Head restraint*" means a device whose purpose is to limit the rearward displacement of an adult occupant's head in relation to his torso in order to reduce the danger of injury to the cervical vertebrae in the event of an accident;
- 2.12.1. "*Integrated head restraint*" means a head restraint formed by the upper part of the seat-back. Head restraints meeting the definitions of paragraphs 2.12.2. or 2.12.3. below but which can only be detached from the seat or the vehicle structure by the use of tools or by partial or complete removal of the seat covering, meet the present definition;
- 2.12.2. "*Detachable head restraint*" means a head restraint consisting of a component separable from the seat designed for insertion and positive retention in the seat-back structure;
- 2.12.3. "*Separate head restraint*" means a head restraint consisting of a component separate from the seat, designed for insertion and/or positive retention in the structure of the vehicle;
- 2.13.4. "*Adjustable head restraint*" means a head restraint that is capable of movement independent of the seatback between at least two positions of adjustment intended for occupant use.
- 2.14. "*Backlight*" means rearward-facing window glazing located at the rear of the roof panel.
- 2.15. "*Backset*" means the horizontal distance between the front surface of the head restraint and the rearmost point of the head.

- 2.16. "*R-point Backset*" means the backset as measured in accordance with Annex 11.
- 2.17. "*BioRID Reference Backset*" means the backset as determined in accordance with Annex 14.
- 2.18. "*H-point*" means the pivot centre of the torso and thigh of the H-point machine when installed in a vehicle seat in accordance with Annex 3. Once determined in accordance with the procedure described in Annex 3, the "H" point is considered fixed in relation to the seat-cushion structure and is considered to move with it when the seat is adjusted in the X direction.
- 2.19. "*R point*" means a design point defined by the vehicle manufacturer for each designated seating position and established with respect to the three-dimensional reference system as defined by Annex 3. The R-point is defined in Annex 3 and:
- 2.19.1. Establishes the rearmost normal design driving or riding position of each designated seating position in a vehicle;
- 2.19.2. Has coordinates established relative to the designed vehicle structure;
- 2.19.3. Simulates the position of the centre pivot of the human torso and thigh.
- 2.20. "*Reference line*" means the line on the manikin reproduced in Annex 3, Appendix 1, Figure 1, to this Regulation.
- 2.21. "*Design torso angle*" means the angle measured with the H-Point machine between a vertical line through the R-point and the torso line in a position which corresponds to the design position of the seat back specified by the vehicle manufacturer.
- 2.22. "*Effective top of the head restraint*" means the highest point on the centreline of the head restraint, determined in accordance with Annex 10 and is designated as intersection point (IP).
- 2.23. "*Head restraint height*" means the distance from the R-point, measured parallel to the torso line to the effective top (IP) of the head restraint on a plane normal to the torso line.
- 2.24. "*Three-dimensional H-point machine*" (H-point machine) means the device used or the determination of "H-points" and actual torso angles. This device is defined in Annex 3.
- 2.25. "*Torso line*" means the centerline of the probe of the H-point machine with the probe in the fully rearward position.
- 2.26. "*Actual torso angle*" means the angle measured using the H-point machine between a vertical line through the H-point and the torso line using the back angle quadrant on the H-point machine.
- 2.27. "*R₅₀-point*" means a design point defined by the vehicle manufacturer for the seated 50th percentile male for the designated seating position.
- 2.28. "*Rebound*" means the movement of the head after contact with the head restraint (i.e. times after T-HRC(end)).
- 2.29. "*Side bolster*" means adjustable seat elements on the sides of the seat cushion and / or of the seat back to allow lateral retention of the occupant.
- 2.30. "*Partitioning system*" means parts or devices which, in addition to the seat-backs, are intended to protect the occupants from displaced luggage; in particular, a partitioning system may be constituted by netting or wire mesh located above the level of the seat-backs in their upright or folded down position. Head restraints fitted as standard equipment for vehicles equipped with such parts or devices shall be considered as part of the partitioning system. However, a seat equipped with a head restraint shall not be considered as being on its own a partitioning system.

3. Application for approval

- 3.1. The application for approval of a vehicle type shall be submitted by the vehicle manufacturer or by his duly accredited representative.
- 3.2. It shall be accompanied by the following documents in triplicate and the following particulars:
 - 3.2.1. A detailed description of the vehicle type with regard to the design of the seats, their anchorages, and their adjustment, displacement and locking systems;
 - 3.2.1.1. A detailed description and/or drawings of the partitioning system, if applicable.
 - 3.2.2. Drawings, on an appropriate scale and in sufficient detail, of the seats, their anchorages on the vehicle, and their adjustment, displacement and locking systems.
 - 3.2.3. In the case of a seat with a detachable head restraint:
 - 3.2.3.1. A detailed description of the head restraint, specifying in particular the nature of the padding material or materials;
 - 3.2.3.2. A detailed description of the location, the type of support and the attachments for mounting the head restraint on the seat.
 - 3.2.4. In the case of a separate head restraint:
 - 3.2.4.1. A detailed description of the head restraint, specifying in particular the nature of the padding material or materials;
 - 3.2.4.2. A detailed description of the location, and the attachments for fitting the head restraint to the structure of the vehicle.
- 3.3. The following shall be submitted to the Technical Service responsible for the approval tests:
 - 3.3.1. A vehicle representative of the vehicle type to be approved or the parts of the vehicle which the Technical Service deems necessary for approval tests;
 - 3.3.2. An additional set of the seats with which the vehicle is equipped, with their anchorages.
 - 3.3.3. For vehicles with seats fitted or capable of being fitted with head restraints, in addition to the requirements set out in paragraphs 3.3.1. and 3.3.2. above:
 - 3.3.3.1. In the case of detachable head restraints: an additional set of seats, fitted with head restraints, with which the vehicle is equipped, together with their anchorages.
 - 3.3.3.2. In the case of separate head restraints: an additional set of the seats with which the vehicle is equipped, with their anchorages, an additional set of the corresponding head restraints and the part of the vehicle structure to which the head restraint is fitted, or a complete structure.

4. Approval

- 4.1. If the vehicle submitted for approval pursuant to this Regulation meets the relevant requirements (seats fitted with head restraints or capable of being fitted with head restraints), approval of the vehicle type shall be granted.
- 4.2. An approval number shall be assigned to each type approved. Its first two digits (at present 10, corresponding to the 10 series of amendments) shall indicate the series of amendments incorporating the most recent major technical amendments made to the Regulation at the time of issue of the approval. The same Contracting Party may not assign the same number either to the same vehicle type equipped with other types of seats or head restraints or with seats anchored differently on the vehicle (this applies both to seats with and to those without head restraints) or to another vehicle type.
- 4.3. Notice of approval or extension or refusal of approval of a vehicle type pursuant to this Regulation shall be communicated to the Parties to the Agreement applying this Regulation by means of a form conforming to the model in Annex 1 to this Regulation.
- 4.4. There shall be affixed, conspicuously and in a readily accessible place specified on the approval form, to every vehicle conforming to a vehicle type approved under this Regulation, an international approval mark consisting of:
 - 4.4.1. A circle surrounding the letter "E" followed by the distinguishing number of the country which has granted approval;²
 - 4.4.2. The number of this Regulation, followed by the letter "R", a dash and the approval number, to the right of the circle prescribed in paragraph 4.4.1. above.
 - 4.4.3. However, if the vehicle is equipped with one or more seats fitted or capable of being fitted with head restraints, approved as meeting the requirements under paragraphs 5.2. and 5.3. below, the number of this Regulation shall be followed by the letters "RA". The form conforming to the model in Annex 1 to this Regulation shall indicate which seat(s) of the vehicle is (are) fitted or capable of being fitted with head restraints. The marking shall also indicate that any remaining seats in the vehicle, not fitted or capable of being fitted with head restraints, are approved and meet the requirements of paragraph 5.2. below of this Regulation.
- 4.5. If the vehicle conforms to a vehicle type approved under one or more other Regulations annexed to the Agreement in the country which has granted approval under this Regulation, the symbol prescribed in paragraph 4.4.1. above need not be repeated; in such a case the Regulation and approval numbers and the additional symbols of all the Regulations under which approval has been granted in the country which has granted approval under this Regulation shall be placed in vertical columns to the right of the symbol prescribed in paragraph 4.4.1. above.
- 4.6. The approval mark shall be clearly legible and be indelible.
- 4.7. The approval mark shall be placed close to or on the vehicle data plate affixed by the manufacturer.
- 4.8. Examples of arrangements of approval marks are given in Annex 2 to this Regulation.

² The distinguishing numbers of the Contracting Parties to the 1958 Agreement are reproduced in Annex 3 to the Consolidated Resolution on the Construction of Vehicles (R.E.3), document ECE/TRANS/WP.29/78/Rev.6, Annex 3 - <https://unece.org/transport/standards/transport/vehicle-regulations-wp29/resolutions>

5. Requirements

- 5.1. General requirements
- 5.1.1. The installation of side-facing seats shall be prohibited in vehicles of categories M₁, N₁, M₂ (of class II, III and B) and M₃ of a technically permissible laden mass not exceeding 10 tonnes (of class II, III and B).
- 5.1.2. It does not apply to ambulances or to vehicles intended for use by the armed services, civil defence, fire services and forces responsible for maintaining public order.
- 5.2. General requirements applicable to all seats of vehicles of category M₁³
- 5.2.1. Every adjustment and displacement system provided shall incorporate a locking system, which shall operate automatically.
- Locking systems for armrests or other comfort devices are not necessary unless the presence of such devices will cause additional risk of injury to the occupants of a vehicle in the event of a collision.
- Folding seats shall lock automatically in the position of use by occupants.
- 5.2.2. The unlocking control for a device as referred to in paragraph 2.7. of this Regulation shall be placed on the outside of the seat close to the door. It shall be easily accessible, even to the occupant of the seat immediately behind the seat concerned.
- 5.2.3. The rear parts of seats situated in area 1, defined in paragraph 6.8.1.1. below shall pass the energy dissipation test in accordance with the requirements of Annex 6 to this Regulation.
- 5.2.3.1. This requirement is deemed to be met if in the tests carried out by the procedure specified in Annex 6 to this Regulation the deceleration of the headform does not exceed 80 g continuously for more than 3 ms. Moreover, no dangerous edge shall occur during or remain after the test.
- 5.2.3.2. The requirements of paragraph 5.2.3. shall not apply to rearmost seats, to back-to-back seats or to seats that comply with the provisions of UN Regulation No. 21 "Uniform Provisions concerning the Approval of Vehicles with regard to their Interior Fittings" (E/ECE/324-E/ECE/TRANS/505/Rev.1/Add.20/Rev.2, as last amended).
- 5.2.4. The surface of the rear parts of seats shall exhibit no dangerous roughness or sharp edges likely to increase the risk of severity of injury to the occupants. This requirement is considered as satisfied if the surface of the rear parts of seats tested in the conditions specified in paragraph 6.1. below exhibit radii of curvature not less than:
- 2.5 mm in area 1,
5.0 mm in area 2,
3.2 mm in area 3.
- These areas are defined in paragraph 6.8.1. below.
- 5.2.4.1. This requirement does not apply to:
- 5.2.4.1.1. the parts of the different areas exhibiting a projection of less than 3.2 mm from the surrounding surface, which shall exhibit blunted edges, provided that the height of the projection is not more than half its width;
- 5.2.4.1.2. Rearmost seats, to back-to-back seats or to seats that comply with the provisions of UN Regulation No. 21 "Uniform provisions concerning the

³ Vehicles of category M₂, which are approved to this Regulation as an alternative to UN Regulation No. 80 (in line with paragraph 1.2. to that Regulation) shall also meet the requirements of this paragraph.

- approval of vehicles with regard to their interior fittings" (E/ECE/324-E/ECE/TRANS/505/Rev.1/ Add.20/Rev.2, as last amended);
- 5.2.4.1.3. Rear parts of seats situated below a horizontal plane passing through the lowest R point in each row of seats. (Where rows of seats have different heights, starting from the rear, the plane shall be turned up or down forming a vertical step passing through the R point of the row of seats immediately in front);
- 5.2.4.1.4. Parts such as "flexible wire mesh".
- 5.2.4.2. In area 2, defined in paragraph 6.8.1.2. below, surfaces may exhibit radii less than 5 mm, but not less than 2.5 mm provided that they pass the energy-dissipation test prescribed in Annex 6 to this Regulation. Moreover, these surfaces shall be padded to avoid direct contact of the head with the seat frame structure.
- 5.2.4.3. If the areas defined above contain parts covered with material softer than 50 Shore A hardness, the above requirements, with the exception of those relating to the energy-dissipation test in accordance with the requirements of Annex 6, shall apply only to the rigid parts.
- 5.2.5. No failure shall be shown in the seat frame or in the seat anchorage, the adjustment and displacement systems or their locking devices during or after the tests prescribed in paragraphs 6.2. and 6.3. below. Permanent deformations, including ruptures, may be accepted, provided that these do not increase the risk of injury in the event of a collision and the prescribed loads were sustained.
- 5.2.6. No release of the locking systems shall occur during the tests described in paragraph 6.3. below and in Annex 9, paragraph 2.1. to this Regulation.
- 5.2.7. After the tests, the displacement systems intended for permitting or facilitating the access of occupants shall be in working order; they shall be capable, at least once, of being unlocked and shall permit the displacement of the seat or the part of the seat for which they are intended.
- Any other displacement systems, as well as adjustment systems and their locking systems are not required to be in working order.
- In the case of seats provided with head restraints, the strength of the seat-back and of its locking devices is deemed to meet the requirements set out in paragraph 6.2. when, after testing in accordance with Annex 5 below, no breakage of the seat or seat-back has occurred: otherwise, it shall be shown that the seat is capable of meeting the test requirements set out in paragraph 6.2. below.
- In the case of seats (benches) with more places to sit than head restraints and in case the manufacturer chooses not to apply 53 daNm during the test of paragraph 3.1. of Annex 5. the seat back strength test of paragraph 6.2. has to be performed in addition to the test of paragraph 3.1. of Annex 5.
- 5.3. General specifications applicable to seats of vehicles of categories N₁, N₂ and N₃ and to seats of vehicles of categories M₂ and M₃ not covered by UN Regulation No. 80.
- With the exception of the provisions of paragraph 5.1., the requirements also apply to side-facing seats of all categories of vehicles.
- 5.3.1. Seats and bench seats shall be firmly attached to the vehicle.
- 5.3.2. Sliding seats and bench seats shall be automatically lockable in all the positions provided.
- 5.3.3. Adjustable seat-backs shall be lockable in all the positions provided.
- 5.3.4. All seats which can be tipped forward or have fold-on backs and folding seats shall lock automatically in the position of use by occupants.

These requirements do not apply to folding seats fitted in wheelchair spaces or areas for standing passengers of vehicles of category M₂ or M₃ of Class I, II or A and folding seat(s) fitted in the access passages of vehicles of category M₂ or M₃.

- 5.4. Mounting of head restraints
 - 5.4.1. A head restraint shall be mounted on every outboard front seat in every vehicle of category M₁. Seats fitted with head restraints, intended for fitment in other seating positions and in other categories of vehicles may also be approved to this Regulation.
 - 5.4.2. A head restraint shall be mounted on every outboard front seat in every vehicle of category M₂ with a maximum mass not exceeding 3500 kg and of category N₁; head restraints mounted in such vehicles shall comply with the requirements of UN Regulation No. 25, as amended by 04 series of amendments.5.5. Special requirements for seats fitted or capable of being fitted with head restraints
 - 5.5.1. The presence of the head restraint shall not be an additional cause of danger to occupants of the vehicle. In particular, it shall not in any position of use exhibit any dangerous roughness or sharp edge liable to increase the risk or seriousness of injury to the occupants.
 - 5.5.1.1. Parts of the front and rear faces of head restraints situated in area 1 as defined in paragraph 6.8.1.1.3. below, shall be so padded as to prevent any direct contact of the head with the components of the structure and shall meet the requirements of paragraph 5.2.4. above.
 - 5.5.1.2. Parts of the front and rear faces of head restraints situated in area 2, as defined in paragraph 6.8.1.2. below, shall be so padded as to prevent any direct contact of the head with the components of the structure and shall meet the requirements of paragraph 5.2.4. above applicable to the rear parts of seats situated in area 2. When paragraph 5.2.4.2. is used for front faces of head restraints the energy dissipation test shall be conducted according to Annex 12. In the case of head restraints integrated with the seat back, the front face of the head restraint is considered as the area located above a plane perpendicular to the reference line at 540 mm from the R point and between two vertical longitudinal planes at 85 mm on either side of the reference line.
 - 5.5.2. Parts of the rear faces of the head restraints situated in area 1, as defined in paragraph 6.8.1.1.3. below shall pass the energy absorption test.
 - 5.5.2.1. This requirement is deemed to be met if in the tests carried out by the procedure specified in Annex 6 the deceleration of the headform does not exceed 80 g continuously for more than 3 ms. Moreover, no dangerous edge shall occur during or remain after the test.
 - 5.5.3. The requirements of paragraphs 5.5.1. and 5.5.2. above, shall not apply to rear parts of head restraints designed to be fitted to seats behind which no seat is provided.
 - 5.5.4. The head restraints shall be secured to the seat or to the vehicle structure in such a way that no rigid and dangerous parts project from the padding of the head restraint or from its attachments to the seat-back as a result of the pressure exerted by the headform during the test.
 - 5.5.5. In the case of a seat fitted with head restraints, the provisions of paragraph 5.2.3. may, after agreement of the Technical Service, be considered to be met if the seat fitted with its head restraint complies with the provisions of paragraph 5.5.2. above.
 - 5.6. Performance Requirements
 - 5.6.1. General Requirements

- 5.6.1.1. Each front outboard head restraint shall conform to either paragraph 5.6.1.1.1. or paragraph 5.6.1.1.2. at the choice of manufacturer.
- 5.6.1.1.1. The head restraint shall conform to paragraphs 5.6.2.1., 5.6.3. through 5.6.7., 5.7., 5.8., and 5.10., of this Regulation.
- 5.6.1.1.2. The head restraint shall conform to paragraphs 5.6.2.1., 5.6.3. through 5.6.5., 5.6.7., 5.8., 5.9., and 5.10., of this Regulation.
- 5.6.1.2. For vehicles equipped with front centre head restraints, the head restraint shall conform to either paragraph 5.6.1.2.1. or paragraph 5.6.1.2.2. at the choice of manufacturer.
- 5.6.1.2.1. The head restraint shall conform to paragraphs 5.6.2.2., 5.6.3. through 5.6.5., 5.6.7., 5.7., 5.8., and 5.10. of this Regulation.
- 5.6.1.2.2. The head restraint shall conform to paragraphs 5.6.2.2., 5.6.3. through 5.6.5., 5.6.7., 5.8., 5.9., and 5.10. of this Regulation.
- 5.6.1.3. For vehicles equipped with rear outboard head restraints, the head restraint shall conform to either paragraph 5.6.1.3.1. or paragraph 5.6.1.3.2. at the choice of manufacturer.
- 5.6.1.3.1. The head restraint shall conform to paragraphs 5.6.2.4., 5.6.3. through 5.6.5., 5.6.7., 5.7., 5.8., and 5.10. of this Regulation.
- 5.6.1.3.2. The head restraint shall conform to paragraphs 5.6.2.4., 5.6.3. through 5.6.5., 5.6.7., 5.8., 5.9., and 5.10. of this Regulation.
- 5.6.1.4. For vehicles equipped with rear centre head restraints, the head restraint shall conform to either paragraph 5.6.1.4.1. or 5.6.1.4.2. at the choice of manufacturer.
- 5.6.1.4.1. The head restraint shall conform to paragraphs 5.6.2.6., 5.6.3. through 5.6.5., 5.6.7., 5.7., 5.8., and 5.10. of this Regulation.
- 5.6.1.4.2. The head restraint shall conform to paragraphs 5.6.2.6., 5.6.3. through 5.6.5., 5.6.7., 5.8., 5.9., and 5.10. of this Regulation.
- 5.6.1.5. If it is impossible to seat the test dummy at the designated seating positions specified under paragraph 5.9. of this regulation, the applicable head restraint shall conform to either paragraph 5.6.1.1.1., or 5.6.1.2.1., or 5.6.1.3.1., or 5.6.1.4.1. of this Regulation, as appropriate.
- 5.6.2. Height of Head Restraint
- The height requirements shall be demonstrated in accordance with the provisions of Annex 10.
- 5.6.2.1. Front outboard designated seating positions
- The height of a head restraint located in a front outboard designated seating position shall have a height of:
- (a) Not less than 830 mm in at least one position of head restraint adjustment; and
- (b) Not less than 720 mm in any position of head restraint adjustment.
- Except as provided for in paragraph 5.6.2.3. of this Regulation.
- 5.6.2.2. Front centre designated seating positions equipped with head restraints
- The height of a head restraint located in the front centre designated seating position shall be not less than 720 mm in any position of adjustment, except as provided in paragraph 5.6.2.3. of this Regulation.
- 5.6.2.3. Exception
- If the interior surface of the vehicle roofline, including the headliner, physically prevents a head restraint, located in the front designated seating

position, from attaining the height required by paragraph 5.6.2.1. or 5.6.2.2. of this Regulation as applicable, the gap between the head restraint and the interior surface of the roofline, including the headliner, when measured in accordance with Annex 10, paragraph 2.3.3.1., shall not exceed 50 mm when the head restraint is adjusted to its highest position intended for occupant use. However, in no instance shall the height of a head restraint located in a front designated seating position be less than 700 mm when the head restraint is adjusted to its lowest position intended for occupant use.

5.6.2.4. Rear outboard designated seating positions equipped with head restraints

The height of a head restraint located in a rear outboard designated seating position shall have a height of not less than 720 mm in any position of adjustment, except as provided in paragraph 5.6.2.5. of this Regulation.

5.6.2.5. Exception

If the interior surface of the vehicle roofline, including the headliner, or backlight physically prevent a head restraint, located in the rear outboard designated seating position, from attaining the height required by paragraph 5.6.2.4. of this Regulation, the gap between the head restraint and interior surface of the roofline, including the headliner, or the backlight when measured in accordance with Annex 10, paragraph 2.3.3.1., shall not exceed 50 mm when the head restraint is adjusted to its highest position intended for occupant use.

5.6.2.6. Rear centre designated seating positions equipped with head restraints

When measured in accordance with Annex 10, the height of any head restraint designed to be provided in rear centre seats or seating positions shall be not less than 700 mm.

5.6.3. Minimum Width

When measured in accordance with Annex 4, the lateral width of a head restraint shall be not less than 85 mm on either side of the torso line (distances L and L').

5.6.4. Gaps within Head Restraint

If a head restraint has any gap greater than 60 mm, when measured in accordance with Annex 8, the maximum rearward displacement of the head form shall be less than 102 mm when the head restraint is tested at that gap in accordance with Annex 5.

In the case of head restraints integral with the seat-back, the area to be considered is:

Above a plane perpendicular to the reference line at 540 mm from the R-point and between two vertical longitudinal planes passing at 85 mm on either side of the reference line.

5.6.5. Gaps between the Head Restraint and the Top of the Seat Back

When measured in accordance with Annex 8, there shall not be a gap greater than 60 mm between the bottom of the head restraint and the top of the seat back if the head restraint cannot be adjusted in height.

In the case of head restraints adjustable in height to more than one position intended for occupant use, when measured in accordance with Annex 8, there shall not be a gap greater than 25 mm between the bottom of the head restraint and the top of the seat back, with the head restraint adjusted to its lowest height position.

5.6.6. Static Maximum Backset Requirement for Front Outboard Designated Seating Positions

5.6.6.1. For height adjustable head restraints, the requirements shall be met with the effective top of the head restraint in all height positions of adjustment

between 720 mm and 830 mm, inclusive. If the effective top of the head restraint, in its lowest position of adjustment, is above 830 mm, the requirements of this Regulation shall be met at that position only.

For head restraints that are adjustable in a longitudinal plane of the vehicle, the maximum backset requirement shall be achieved in any position of the available backset adjustment.

5.6.6.2. When measured in accordance with Annex 11, the backset shall not be more than 45mm.

5.6.6.3. If the front outboard head restraint is not attached to the seat back, it shall not be possible to adjust the seat or head restraint such that the backset is more than 45mm.

5.6.7. The height of the front contact surface of the head restraints, measured as described in Figure 10-6 of Annex 10 shall not be less than 100mm except for integrated head-restraints.

5.7. Static Performance Requirements

Each head restraint shall conform with the following static requirements.

5.7.1. Energy absorption

When the front surface of the head restraint is impacted in accordance with Annex 12, the deceleration of the headform shall not exceed 785 m/s^2 (80g) continuously for more than 3 milliseconds. Moreover, no dangerous edge shall occur during or remain after the test.

5.7.2. Displacement

When the head restraint is tested in accordance with Annex 5, the headform shall not be displaced more than 102 mm perpendicularly and rearward of the displaced extended torso reference line, "r1", during the application of a 373 Nm moment about the R-point.

5.7.3. Head restraint and its anchorage strength

When the head restraint and its anchorage are tested in accordance with Annex 5, the load applied to the head restraint shall reach 890 N and remain at this load for a minimum period of 5 seconds unless any breakage of the seat or head restraint occurs.

5.7.4. Adjustable head restraint height retention

When tested in accordance with Annex 13, the mechanism of the adjustable head restraint shall not fail in such a way as to allow downward movement of the head restraint by more than 25 mm.

5.8. Non-Use Positions

5.8.1. A driver head restraint shall not have a non-use position.

5.8.2. A front outboard passenger head restraint may be adjusted to a position at which its height does not comply with the requirements of paragraph 5.6.2.1. of this Regulation. However, in any such position, the front outboard passenger head restraint shall meet paragraph 5.8.4.1. of this Regulation.

5.8.3. All rear head restraints and any front centre head restraint may be adjusted to a position at which its height does not comply with the requirements of paragraphs 5.6.2.2., 5.6.2.4. or 5.6.2.6. of this Regulation. However, in any such position, the head restraint shall also meet one additional requirement from a set of several alternative requirements.

The set of alternative requirements may be, at the choice of the manufacturer, either paragraph 5.8.4.1., 5.8.4.2., 5.8.4.3., 5.8.4.4., or 5.8.4.5. of this Regulation.

- 5.8.4. Alternative requirements for head restraints capable of a non-use position
 All of the items described in paragraphs 5.8.4.1. through 5.8.4.5. are permitted.
- 5.8.4.1. In all designated seating positions equipped with head restraints, except the driver's designated seating position, the head restraint shall automatically return from a non-use position to a position in which its minimum height is not less than that specified in paragraph 5.6.2. of this Regulation when a 5th percentile female Hybrid III test dummy is positioned in the seat in accordance with Annex 15. At the option of the manufacturer, instead of using a 5th percentile female Hybrid-III test dummy, human surrogates may be used as specified in Annex 15.
- 5.8.4.2. In front centre and rear designated seating positions equipped with head restraints, the head restraint shall, when tested in accordance with Annex 15, be capable of manually rotating either forward or rearward by not less than 60° from any position of adjustment intended for occupant use in which its minimum height is not less than that specified in paragraph 5.6.2. of this Regulation. A head restraint rotated by minimum 60° forward or rearward, is considered to be placed in a non-use position even if the head restraint height in such a position would be greater than that specified in paragraph 5.6.2.
- 5.8.4.3. When measured in accordance with Annex 15, the height of the lower edge of the head restraint (HLE) shall be not more than 460 mm, but not less than 250 mm from the R-Point and the thickness (S) shall not be less than 40 mm.
- 5.8.4.4. When tested in accordance with Annex 15, the head restraint shall cause the actual torso angle to be at least 10° less than when the head restraint is in any position of adjustment in which its height is not less than that specified in paragraph 5.6.2. of this Regulation.
- 5.8.4.5. The presence of a non-use position of a head restraint shall be marked with a label, in the form of a pictogram which may include explanatory text. The label shall either provide an indication when the head restraint is in a non-use position or provide information to enable an occupant to determine whether the head restraint is in a non-use position. The label shall be durably affixed and located such that it is clearly visible by an occupant when entering the vehicle to the designated seating position. Examples of possible designs of pictograms are shown in Figure 1.

Figure 1
 Non-Use Warning Labels

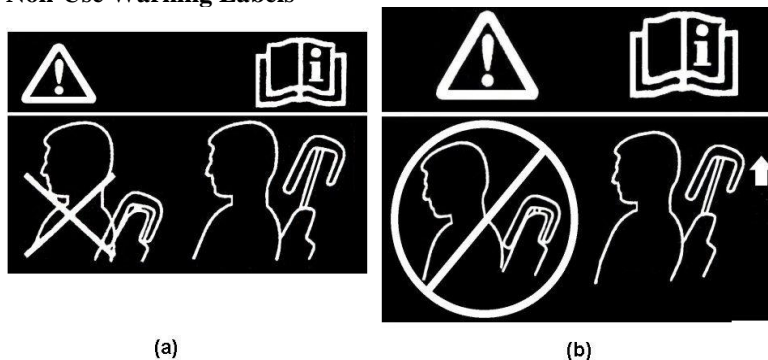

- 5.9. BioRID II Requirements
 Until further evaluation is conducted, the use of the BioRID II UN dummy is limited to seats having a design torso angle no less than 20° and no greater than 30°. However, at the manufacturer's request, seats with a design torso angle between 15° and 20° may be tested at a torso angle of 20° or the closest locking position above.

- 5.9.1. Each head restraint, when tested during forward acceleration of the dynamic test platform, using BioRID II UN 50th percentile male dummy in accordance with Annex 14, shall conform to the requirements of paragraph 5.9.2.
- 5.9.2. Evaluation Criteria
- Each head restraint shall control the movement of the head and neck within the following limits:

Table 1
Injury Criteria

<i>NIC</i>	<i>Max</i>	$25 \text{ m}^2/\text{s}^2$
Upper Neck	FX	360N
	<i>MY(Flx/Ext)</i>	30Nm
Lower Neck	FX	Monitor
	<i>MY(Flx/Ext)</i>	30Nm

Note: The injury criteria shall be calculated excluding rebound movement of the head. For the injury criteria of upper and lower neck, both the positive and negative values shall be assessed.

- 5.10. If the head restraint is adjustable, it shall not be possible to raise it beyond the maximum operational height, or remove it, except by deliberate action on the part of the user distinct from any act necessary for its upward adjustment.
- 5.11. The strength of the seat-back and of its locking devices is deemed to meet the requirements set out in paragraph 6.2. below when, after testing in accordance with paragraph 5.7.3. above, no breakage of the seat or seat-back has occurred; otherwise, it shall be shown that the seat is capable of meeting the test requirements set out in paragraph 6.2. below without breakage.
- 5.12. Special requirements regarding the protection of occupants from displaced luggage
- 5.12.1. Seat-backs
- Seat-backs and/or head restraints located such that they constitute the forward boundary of the luggage compartment, all seats being in place and in the normal position of use as indicated by the manufacturer, shall have sufficient strength to protect the occupants from displaced luggage in a frontal impact. This requirement is deemed to be met if, during and after the test described in Annex 9, the seat-backs remain in position, and the locking mechanisms remain in place. However, the deformation of the seat-backs and their fastenings during the test is permitted, provided that the forward contour of the parts of the tested seat-back and/or head restraints, that are harder than 50 Shore A, does not move forward of a transverse vertical plane which passes through:
- A point of 150 mm forward of the R point of the seat in question, for the parts of the head restraint;
 - A point of 100 mm forward of the R point of the seat in question, for parts of the seat-back;

excluding the rebound phases of the test blocks.

For integrated head restraints, the limit between the head restraint and the seat-back is defined by the plane perpendicular to the reference line 540 mm from the R point.

All measurements shall be taken in the longitudinal median plane of the corresponding seat or seating position for each seating position constituting the forward boundary of the luggage compartment.

During the test described in Annex 9, the test blocks shall remain behind the seat-back(s) in question. In case of damage to a safety-belt retractor, it shall be verified that the retractor is locked as a result of the test or that it can be locked by a manual pull out of the strap.

5.12.2. Partitioning systems

At the request of the vehicle manufacturer, the test described in Annex 9 may be carried out with the partitioning systems in place, if these systems are fitted as standard equipment for the particular type of vehicle.

Partitioning systems, netting wire mesh located above the seat-backs in their normal position of use, shall be tested according to paragraph 2.2. of Annex 9.

This requirement is deemed to be met if, during the test, the partitioning systems remain in position. However, the deformation of the partitioning systems during the test is permitted, provided that the forward contour of the partitioning (including parts of the tested seat-back(s) and/or head restraint(s) that are harder than 50 Shore A does not move forward of a transverse vertical plane which passes through:

- (a) A point of 150 mm forward of the R point of the seat in question, for parts of the head restraint;
- (b) A point of 100 mm forward of the R point of the seat in question, for parts of the seat-back and part of the partitioning system others than the head restraint.

For integrated head restraint, the limit between the head restraint and the seat-back is the one defined in paragraph 5.12.1.

All measurements shall be taken in the longitudinal median plane of the corresponding seat or seating position for each seating position constituting the forward boundary of the luggage compartment.

After the test, no sharp or rough edges likely to increase the danger or severity of injuries of the occupants shall be present. In case of damage to a safety-belt retractor, it shall be verified that the retractor is locked already or that it can be locked by a manual pull out of the strap.

- 5.12.3. The requirements mentioned in paragraph 5.12.1. and 5.12.2. above shall not apply to luggage retention systems which are activated automatically in case of an impact. The manufacturer shall demonstrate to the satisfaction of the Technical Service that the protection offered by such systems is equivalent to that described in paragraph 5.12.1. and 5.12.2.

6. Tests

6.1. General specifications applicable to all tests

6.1.1. The seat-back, if adjustable, shall be locked in a position corresponding to a rearward inclination as close as possible to 25° from the vertical of the torso reference line of the manikin described in Annex 3, unless otherwise specified by the manufacturer.

6.1.2. When a seat, its locking mechanism and its installation are identical or symmetrical with respect to another seat on the vehicle, the Technical Service may test only one such seat.

- 6.1.3. In the case of seats with adjustable head restraints, the tests shall be conducted with the head restraints placed in the most unfavourable position (generally, the highest position) allowed by its adjusting system.
- 6.1.4. Folding seats shall be tested in the position of use by occupants.
- 6.1.5. To demonstrate compliance with paragraph 5.6. through to 5.8. of this Regulation, any adjustable support shall be positioned in its most rearward or opened design position.
- 6.2. Test of strength of the seat-back and its adjustment systems
- 6.2.1. A force producing a moment of 53 daNm in relation to the R point shall be applied longitudinally and rearwards to the upper part of the seat-back frame through a component simulating the back of the manikin shown in Appendix 1 of Annex 3 to this Regulation.
- In the case of a bench seat, where part or all of the supporting frame (including that of the head restraints) is common to more than one seating position, the displacement and strength test shall be conducted simultaneously for all those seating positions.
- 6.3. Test of strength of the seat anchorage and the adjustment, locking and displacement systems.
- 6.3.1. A longitudinal horizontal deceleration or, at the choice of the applicant, acceleration of not less than 20 g shall be applied for 30 milliseconds in a direction to the whole shell of the vehicle imitating a frontal collision, in accordance with the requirements of Annex 7, paragraph 1. At the request of the manufacturer the test pulse described in Annex 9 - Appendix may be used alternatively.
- 6.3.2. A longitudinal deceleration or, at the choice of the applicant, acceleration in accordance with the requirements of paragraph 6.3.1. shall be applied imitating a rear collision.
- 6.3.3. The requirements of paragraphs 6.3.1. and 6.3.2. above shall be verified for all positions of the seat. In the case of seats fitted with an adjustable head restraint, the test shall be conducted with the head restraints placed in the most unfavourable position (generally the highest position) allowed by its adjusting system. During the test the seat shall be so positioned that no external factor shall prevent the release of the locking systems.
- These conditions shall be considered to be met if the seat is tested after being adjusted in the following positions:
- The longitudinal adjustment is fixed one notch or 10 mm rearward of the most forward normal driving position or position of use as indicated by the manufacturer (for seats with independent vertical adjustment, the cushion shall be placed in its highest position);
- The longitudinal adjustment is fixed one notch or 10 mm forward of the most rearward normal driving position or position of use as indicated by the manufacturer (for seats with independent vertical adjustment, the cushion shall be placed in its lowest position), and, where appropriate, in accordance with the requirements of paragraph 6.3.4. below.
- 6.3.4. In cases where the arrangement of the locking systems is such that, in a seat position other than those defined in paragraph 6.3.3. above, the distribution of the forces on the locking devices and seat anchorages would be less favourable than with either configuration defined in paragraph 6.3.3. above, the tests shall be conducted for that less favourable seating position.
- 6.3.5. The test conditions of paragraph 6.3.1. above shall be considered to be satisfied if, at the request of the manufacturer, they are replaced by a collision test of the complete vehicle in running order against a rigid barrier as laid down in

paragraph 2. of Annex 7 to this Regulation. In this case, the seat shall be adjusted for the least favourable conditions of distribution of stresses in the anchorage system as provided for in paragraphs 6.1.1., 6.3.3. and 6.3.4. above.

- 6.4. Test of the performance of the head restraint
 - 6.4.1. If the head restraint is adjustable, it shall be placed in the most unfavourable position (generally the highest position) allowed by its adjustment system.
 - 6.4.2. In the case of a bench seat, where part or all of the supporting frame (including that of the head restraints) is common to more than one seating position, the test shall be conducted simultaneously for all those seating positions.
 - 6.4.3. Test for determining rearward displacement for the head restraint.
- 6.5. Determination of the height of the head restraint
 - 6.5.1. The height of any head restraint is determined in accordance with Annex 10.
 - 6.5.2. The manikin described in Annex 3 to this Regulation shall be placed in a normal position on the seat.
 - 6.5.3. The projection of the reference line of the manikin shown in Annex 3 to this Regulation is then, in the seat concerned, drawn in the plane specified in paragraph 6.4.3.1. above.

The tangent S to the top of the head restraint is drawn perpendicular to the reference line.
 - 6.5.4. The distance "h" from the R point to the tangent S is the height to be taken into consideration in implementing the requirements of paragraph 5.6. above.
- 6.6. Determination of the width of the head restraint
 - 6.6.1. The width of any head restraint is determined in accordance with Annex 4.
 - 6.6.2. The width of the head restraint to be taken into consideration in implementing the requirements of paragraph 5.6.3. above, is the distance "L" and "L'" measured in the plane S1 between the vertical longitudinal planes P and P'.
- 6.7. Determination of distance "a" of head restraint gaps.
 - 6.7.1. The distance "a" of head restraint gaps is determined in accordance with Annex 8.
- 6.8. Tests for checking energy dissipation on the seat-back and head restraint
 - 6.8.1. The surfaces of the rear parts of seats to be checked are those situated in the areas defined below which can be contacted by a 165 mm diameter sphere when the seat is mounted in the vehicle.
 - 6.8.1.1. Area 1
 - 6.8.1.1.1. In the case of separate seats without head restraints, this area shall include the rear part of the seat-back between the longitudinal vertical planes situated at 100 mm on either side of the longitudinal median plane of the seat centre line, and above a plane perpendicular to the reference line 100 mm below the top of the seat-back.
 - 6.8.1.1.2. In the case of bench seats without head restraints, this area shall extend between the longitudinal vertical planes situated at 100 mm on either side of the longitudinal median plane of each designated outboard seating position defined by the manufacturer and above a plane perpendicular to the reference line 100 mm below the top of the seat-back.
 - 6.8.1.1.3. In the case of seats or bench seats with head restraints, this area shall extend between the longitudinal vertical planes, on either side of and 70 mm from the longitudinal median plane of the seat or of the seating position concerned and situated above the plane perpendicular to the reference line 635 mm from the R point. For the test, the head restraint, if adjustable shall be placed in the most

unfavourable position (generally the highest) permitted by its adjustment system.

6.8.1.2. Area 2

6.8.1.2.1. In the case of seats or bench seats without head restraints and seats or bench seats with detachable or separate head restraints, area 2 shall extend above a plane perpendicular to the reference line 100 mm distant from the top of the seat-back, other than parts of area 1.

6.8.1.2.2. In the case of seats or bench seats with integrated head restraints, area 2 shall extend above a plane perpendicular to the reference line 440 mm distant from the R point of the seat or of the seating position concerned, other than parts of area 1.

6.8.1.3. Area 3

6.8.1.3.1. Area 3 is defined as the part of the back of the seat or the bench seats situated above the horizontal planes defined in paragraph 5.2.4.1.3. above, excluding parts situated in area 1 and area 2.

6.9. Equivalent test methods

If a test method other than those specified in paragraphs 6.2., 6.3. above or in Annex 5, Annex 6, or Annex 12 is used, its equivalence shall be proven.

7. Conformity of production

The conformity of production procedures shall comply with those set out in the Agreement, (Schedule 1, E/ECE/TRANS/505/Rev.3), with the following requirements:

7.1. Every vehicle approved pursuant to this Regulation shall be so manufactured as to conform to the type approved by meeting the requirements set out in paragraph 5. above. However, in the case of head restraints as defined in paragraph 2.13.2. and 2.13.3. above, nothing shall prevent the vehicle from conforming to the vehicle type approved, even if it is marketed with seats not fitted with head restraints

7.2. The Type Approval Authority which granted type approval may at any time verify the conformity control methods applied for each production unit. The authority may also carry out random checks on serially-manufactured vehicles in respect to the requirements set out in paragraph 5. above.

8. Penalties for non-conformity of production

8.1. The approval granted in respect of a vehicle type pursuant to this Regulation may be withdrawn if the requirements laid down in paragraph 7.1. above are not complied with or if the vehicles fail in the checks prescribed in paragraph 7. above.

8.2. If a Party to the Agreement applying this Regulation withdraws an approval it has previously granted, it shall forthwith so notify the other Contracting Parties applying this Regulation by means of a communication form conforming to the model in Annex 1 to this Regulation.

9. Modifications of the vehicle type and extension of approval with respect to the seats, their anchorages and/or their head restraints

- 9.1. Every modification of the vehicle type with respect to the seats, their anchorages and/or their head restraints shall be notified to the Type Approval Authority which approved the vehicle type. The Authority may then either:
- 9.1.1. Consider that the modifications made are unlikely to have an appreciable adverse effect, and that in any event the vehicle still complies with the requirements; or
- 9.1.2. Consider that the modifications are sufficiently unimportant for the results specified in paragraph 6.2., 6.3. and 6.4. above to be verified by calculations based on the approval test results; or
- 9.1.3. Require a further report from the Technical Service responsible for conducting the tests.
- 9.2. Confirmation or refusal of approval, specifying the modifications, shall be communicated to the Parties to the Agreement applying this Regulation by means of the procedure laid down in paragraph 4.3. above.
- 9.3. The Type Approval Authority issuing the extension of approval shall assign a series number for such an extension and inform thereof the other Parties to the 1958 Agreement applying this Regulation by means of a communication form conforming to the model in Annex 1 to this Regulation.

10. Production definitively discontinued

- 10.1. If the holder of the approval completely ceases to manufacture a device approved in accordance with this Regulation, he shall so inform the authority which granted the approval. Upon receiving the relevant communication that authority shall inform thereof the other Parties to the 1958 Agreement applying this Regulation by means of a communication form conforming to the model in Annex 1 to this Regulation.

11. Instruction for use

- 11.1. For seats fitted with adjustable head restraints, the manufacturers shall provide instructions on how to operate, adjust, lock and, where applicable, remove the head restraints.

12. Names and addresses of Technical Services responsible for conducting approval tests and of Type Approval Authorities

The Contracting Parties to the Agreement applying this Regulation shall communicate to the United Nations Secretariat the names and addresses of the Technical Services responsible for conducting approval tests and of the Type Approval Authority which grant approval and to which forms certifying approval or extension or refusal or withdrawal of approval, issued in other countries, are to be sent.

13. Transitional provisions

- 13.1. As from the official date of entry into force of the 06 series of amendments, no Contracting Party applying this Regulation shall refuse to grant approvals under this Regulation as amended by the 06 series of amendments.
- 13.2. As from 1 October 1999, Contracting Parties applying this Regulation shall grant approvals only if the requirements of this Regulation, as amended by the 06 series of amendments, are satisfied.
- 13.3. As from 1 October 2001, Contracting Parties applying this Regulation may refuse to recognize approvals which were not granted in accordance with the 06 series of amendments to this Regulation.
- 13.4. As from the official date of entry into force of the 07 series of amendments, no Contracting Party applying this Regulation shall refuse to grant approvals under this Regulation as amended by the 07 series of amendments.
- 13.5. As from 24 months after the date of entry into force of the 07 series of amendments, Contracting Parties applying this Regulation shall grant approval only if the vehicle type to be approved complies with the requirements of this Regulation as amended by the 07 series of amendments.
- 13.6. As from 48 months after the date of entry into force of the 07 series of amendments, existing approvals to this Regulation shall cease to be valid, except in the case of vehicle types which comply with the requirements of this Regulation as amended by the 07 series of amendments.
- 13.7. As from the official date of entry into force of the 08 series of amendments, no Contracting Party applying this Regulation shall refuse to grant approvals under this Regulation as amended by the 08 series of amendments.
- 13.8. As from 24 months after the date of entry into force of the 08 series of amendments, Contracting Parties applying this Regulation shall grant approvals only if the requirements of this Regulation, as amended by the 08 series of amendments, are satisfied.
- 13.9. As from 36 months after the date of entry into force of the 08 series of amendments, Contracting Parties applying this Regulation may refuse to recognize approvals which were not granted in accordance with the 08 series of amendments to this Regulation.
- 13.10. Notwithstanding paragraphs 13.8. and 13.9., approvals of the vehicle categories which are not affected by the 08 series of amendments shall remain valid and Contracting Parties applying the Regulation shall continue to accept them.
- 13.11. As long as there are no requirements forbidding side-facing seats in their national requirements at the time of acceding to this Regulation, Contracting Parties may continue to allow the fitting of side-facing seats for the purpose of national approval and in this case these bus categories cannot be type approved under this Regulation.
- 13.12. As from the official date of entry into force of the 09 series of amendments, no Contracting Party applying this Regulation shall refuse to grant or refuse to accept type approvals under this Regulation as amended by the 09 series of amendments.
- 13.12.1. As from 1 September 2020, Contracting Parties applying this Regulation shall not be obliged to accept type approvals to the preceding series of amendments that were first issued on or after 1 September 2020.

- 13.12.2. Until 1 September 2022, Contracting Parties applying this Regulation shall accept type approvals to the preceding series of amendments that were first issued before 1 September 2020.
- 13.12.3. As from 1 September 2022, Contracting Parties applying this Regulation shall not be obliged to accept type approvals issued to the preceding series of amendments to this Regulation.
- 13.12.4. Notwithstanding paragraph 13.12.3., Contracting Parties applying this Regulation shall continue to accept type-approvals to the preceding series of amendments to this Regulation, for vehicles which are not affected by the changes introduced by the 09 series of amendments.
- 13.12.5. Contracting Parties applying this Regulation shall not refuse to grant type approvals according to any preceding series of amendments to this Regulation or extensions thereof.
- 13.13. As from the official date of entry into force of the 10 series of amendments, no Contracting Party applying this Regulation shall refuse to grant or refuse to accept UN type approvals under this Regulation as amended by the 10 series of amendments.
- 13.13.1. As from 1 September 2022, Contracting Parties applying this Regulation shall not be obliged to accept UN type approvals to the preceding series of amendments that were first issued on or after 1 September 2022.
- 13.13.2. Until 1 September 2026, Contracting Parties applying this Regulation shall accept UN type approvals to the preceding series of amendments that were first issued before 1 September 2022.
- 13.13.3. As from 1 September 2026, Contracting Parties applying this Regulation shall not be obliged to accept type approvals issued to the preceding series of amendments to this Regulation.
- 13.13.4. Notwithstanding paragraph 13.13.3., Contracting Parties applying the Regulation shall continue to accept UN type approvals to the preceding series of amendments to the Regulation, for vehicles which are not affected by the changes introduced by the 10 series of amendments.
- 13.13.5. Contracting Parties applying this Regulation shall not refuse to grant UN type approvals according to any preceding series of amendments to this Regulation or extensions thereof.

Annex 1

Communication

(Maximum format: A4 (210 x 297 mm))



issued by: Name of Administration:
.....
.....
.....

Concerning:² Approval granted
 Approval extended
 Approval refused
 Approval withdrawn
 Production definitively discontinued

of a vehicle type with regard to the strength of the seats and their anchorages, in the case either of seats fitted or capable of being fitted with head restraints or of seats not capable of being fitted with such devices and the characteristics of head restraints pursuant to UN Regulation No. 17

Approval No..... Extension No.....

1. Trade name or mark of the motor vehicle
2. Vehicle type
3. Manufacturer's name and address
4. If applicable, name and address of the manufacturer's representative
5. Description of seats
6. Number of seats fitted or capable of being fitted with head restraints, adjustable or not adjustable
7. Description of the adjustment, displacement and locking systems of the seat or of its parts and a description of occupant protection system against displacement of luggage:
8. Description of seat anchorage:.....
9. Longitudinal position of the seats during the tests:
10. Type of device: deceleration/acceleration²
11. Vehicle submitted for approval on:
12. Technical Service responsible for conducting approval tests:

¹ Distinguishing number of the country which has granted/extended/refused/withdrawn approval (see approval provisions in the Regulation).

² Strike out what does not apply.

-
13. Date of report issued by that Service:
 14. Number of report issued by that Service:
 15. Remarks (Also state monitoring values):
 16. Approval is granted/extended/refused/withdrawn²
 17. Reason(s) of extension (if applicable)
 18. Position of approval mark on the vehicle.....
 19. Place:
 20. Date:
 21. Signature:
 22. The following documents, bearing the approval number shown above, are annexed to this communication:

Drawings, diagrams and plans of the seats, their anchorage on the vehicle, the adjustment and displacement systems of the seats and their parts, and their locking devices;

Photographs of the seats, their anchorages, the adjustment and displacement systems of the seats and their parts, and their locking devices, and of additional occupant protection system against displacement of luggage.

Note: In the case of seats fitted with head restraints as defined in paragraphs 2.13.2. and 2.13.3. of this Regulation, the head restraint shall be shown on all drawings, diagrams and photographs.

Annex 2

Arrangements of the Approval Mark

Model A

(see paragraphs 4.4., 4.4.1., 4.4.2. and 4.4.3. of this Regulation)

Vehicle with at least one seat fitted or capable of being fitted with a head restraint



$a = 8 \text{ mm min.}$

The above approval mark when affixed to a vehicle shows that the vehicle type concerned, with regard to the strength of the seats fitted or capable of being fitted with head restraints and with regard to characteristics of the head restraints, has been approved in the Netherlands (E 4) pursuant to UN Regulation No. 17, under the approval number 102439. The first two digits of the approval number indicate that the Regulation already contained the 10 series of amendments at the time of approval. The above approval mark also shows that the vehicle type was approved pursuant to UN Regulation No. 17 with regard to the strength of any seats on the vehicle which are not fitted or capable of being fitted with head restraints.

Model B

(see paragraphs 4.4.; 4.4.1. and 4.4.2. of this Regulation)

Vehicle with seats not fitted or not capable of being fitted with head restraints



$a = 8 \text{ mm min.}$

The above approval mark when affixed to a vehicle shows that the vehicle type has seats not fitted or capable of being fitted with head restraints, and has, with regard to the strength of the seats and their anchorages, been approved in the Netherlands (E 4) pursuant to UN Regulation No. 17 under the approval number 102439. The first two digits of the approval number indicate that the UN Regulation already contained the 10 series of amendments at the time of approval.

Model C

(see paragraphs 4.5. of this Regulation)

Vehicle with at least one seat fitted or capable of being fitted with a head restraint

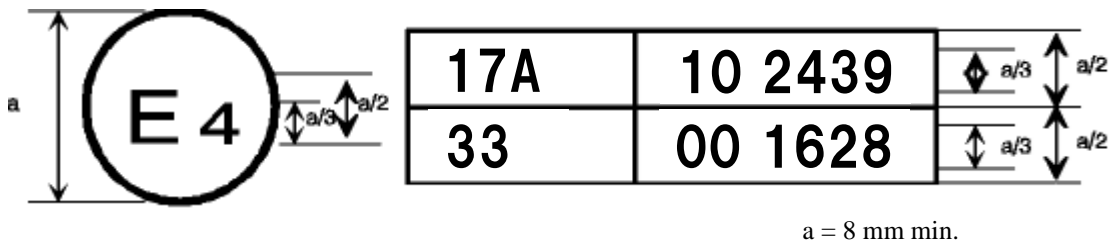

The above approval mark when affixed to a vehicle shows that the vehicle type has at least one seat fitted or capable of being fitted with a head restraint, and was approved in the Netherlands (E 4) pursuant to UN Regulations Nos. 17 and 33.¹

The approval numbers indicate that, on the dates when approval was granted, UN Regulation No. 17 included the 10 series of amendments, but UN Regulation No. 33 was still in its original form. The above approval mark also shows that the vehicle type was approved pursuant to UN Regulation No. 17 with regard to the strength of any seats on the vehicle which are not fitted or capable of being fitted with head restraints.

Model D

(see paragraphs 4.5. of this Regulation)

Vehicle with seats not fitted or not capable of being fitted with head restraints

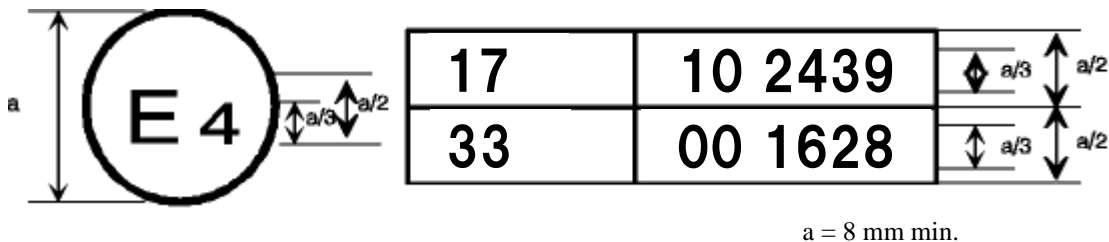

The above approval mark when affixed to a vehicle shows that the vehicle type has seats not fitted or capable of being fitted with head restraints, and was approved in the Netherlands (E 4) pursuant to UN Regulations Nos. 17 and 33.¹ The approval numbers indicate that, on the dates when approval was granted, UN Regulation No. 17 included the 10 series of amendments but UN Regulation No. 33 was still in its original form

¹ The second number is given merely as an example.

Annex 3

Procedure for determining the "H" point and the actual torso angle for seating positions in motor vehicles¹

Appendix 1 - Description of the three dimensional "H" point machine¹

Appendix 2 - Three-dimensional reference system¹

Appendix 3 - Reference data concerning seating positions¹

¹ The procedure is described in Annex 1 and its Appendices 1, 2 and 3 to the Consolidated Resolution on the Construction of Vehicles (R.E.3) (document ECE/TRANS/WP.29/78/Rev.6 - www.unece.org/trans/main/wp29/wp29wgs/wp29gen/wp29resolutions.html)

Annex 4

Minimum Width Measurement Test Procedure

1. Purpose
The purpose of this test procedure is to demonstrate compliance with the minimum width requirements described in paragraph 5.6.3. of this Regulation.
2. Procedure for Width Measurement
 - 2.1. The seat shall be adjusted such that its H-point coincides with the R-point; if the seat back is adjustable, it is set at the design seat back angle; both these adjustments shall be in accordance with the requirements of paragraph 2.1. of Annex 11.
 - 2.2. The plane S1 is a plane perpendicular to the reference line and situated 65 ± 3 mm below the effective top of the head restraint.
 - 2.3. Planes P and P' are vertical longitudinal planes, tangential to each side of the head restraint to be measured.
 - 2.4. Measure the distances L and L' in the plane S1 between the vertical longitudinal planes passing through the torso line and the planes P and P'.

Figure 4-1

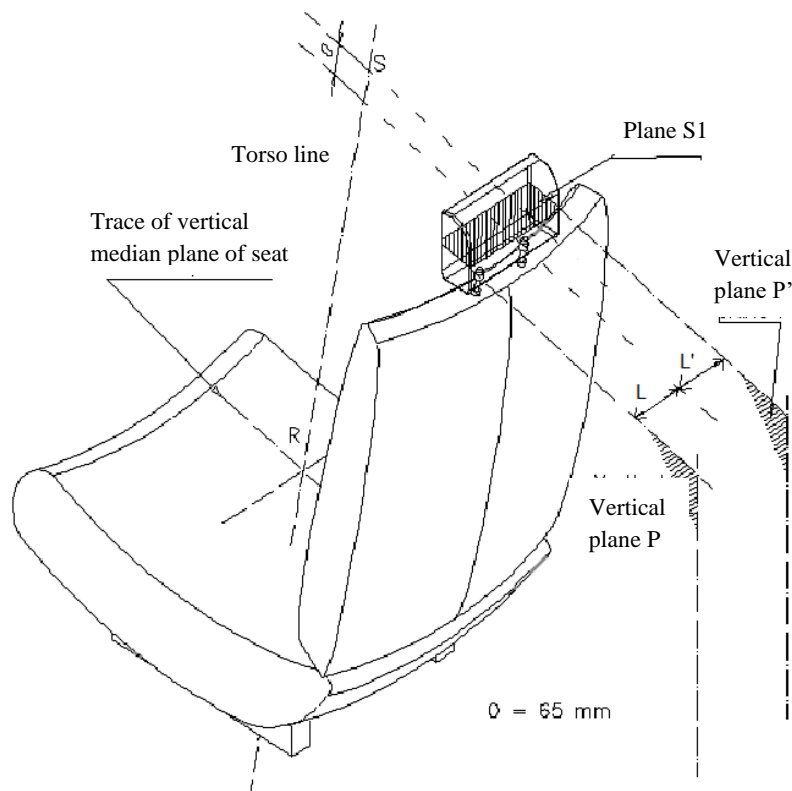

Annex 5

Displacement and Strength Test Procedure

1. Purpose

To demonstrate compliance with the displacement requirements of paragraph 5.6.4. of this Regulation with paragraph 2. of this annex.

Demonstrate compliance with the displacement requirements of paragraph 5.7.2. of this Regulation with paragraph 2. of this annex.

Demonstrate compliance with the strength requirements of paragraph 5.7.3. of this Regulation with paragraph 3. of this annex.
2. Procedure for Displacement

The load vectors that generate moment on the head restraint are initially contained in a vertical plane parallel to the vehicle longitudinal zero plane.
- 2.1. Seat set-up

If the seat back is adjustable, it is adjusted to a position specified by the vehicle manufacturer. If there is more than one inclination position closest to the position specified by the manufacturer, set the seat back inclination to the position closest to and rearward of the manufacturer specified position. If the head restraint position is independent of the seat back inclination position, compliance is determined at a seat back inclination position specified by the manufacturer. Adjust the head restraint to the highest position of vertical adjustment intended for occupant use. Adjust the head restraint to the rearmost (relative to the seat) position of horizontal adjustment backset position.
- 2.2. In the seat, place a test device having, when viewed laterally, the back pan dimensions and torso reference line (vertical centre line) of the three dimensional H-point machine, as specified in Annex 3, with the head room probe in the full back position.
- 2.3. Establish the displaced torso line by creating a rearward moment of 373 ± 7.5 Nm about the R-point by applying a force to the seat back through the back pan at the rate of 2.5 Nm/second to 3.7 Nm/second. The initial location on the back pan of the moment generating force vector has a height of $290 \text{ mm} \pm 13$ mm. Apply the force vector normal to the torso line and maintain it within 2° of a vertical plane parallel to the vehicle vertical longitudinal zero plane. Constrain the back pan to rotate about the R-point. Rotate the force vector direction with the back pan. In the case of simultaneous testing of bench seats, the rearward moment shall be applied to all seating positions of the bench simultaneously, irrespective of this position being equipped with or without head restraint.
- 2.4. Maintain the position of the back pan as established in paragraph 2.3. of this annex. Using a 165 ± 2 mm diameter spherical headform establish the headform initial reference position by applying, perpendicular to the displaced torso line, a rearward initial load at the seat centreline at a height 65 ± 3 mm below the effective top of the head restraint that will produce a 373 ± 7.5 Nm moment about the R-point. Maintain this moment for 5 seconds and then record the rearward displacement of the headform with the load applied.
- 2.5. When determining the rearward displacement for head restraints at a gap greater than 60 mm in accordance with paragraph 5.6.4. of this Regulation, the above load shall be applied through the centre of gravity of the smallest of the sections of the gap, along transversal planes parallel to the torso line.

- 2.6. If the presence of gaps prevents the application of the force, as described in paragraph 2.4. of this annex at 65 ± 3 mm from the effective top of the head restraint, the distance may be reduced so that the axis of the force passes through the centre line of the frame element nearest to the gap.
3. Strength.
- 3.1. Increase the load specified in paragraph 2.4. of this annex at a rate between 5 N/second and 200 N/second to $890 \text{ N} \pm 5 \text{ N}$ and maintain the applied load for 5 seconds without any breakage of the seat or head restraint.

Figure 5-1

r: reference line

r1: displaced reference line

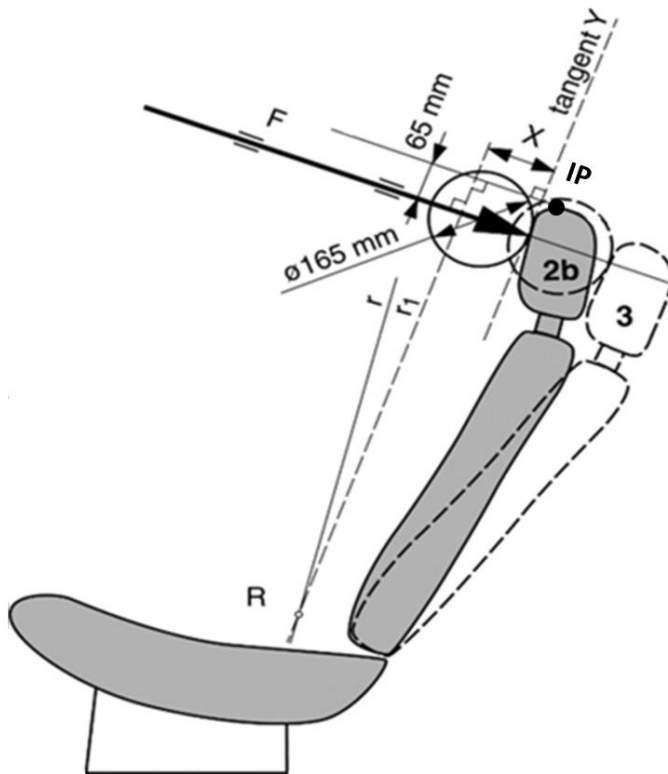

Annex 6

Test procedure for checking energy dissipation

1. Installation, test apparatus, recording instruments and procedure
 - 1.1. Setting up

The seat, as mounted in the vehicle, shall be firmly secured to the test bench with the attachment parts provided by the manufacturer, so as to remain stationary when the impact is applied.

The seat-back, if adjustable, shall be locked in the position specified in paragraph 6.1.1. of this Regulation.

If the seat is fitted with a head restraint, the head restraint shall be mounted on the seat-back as in the vehicle. Where the head restraint is separate, it shall be secured to the part of the vehicle structure to which it is normally attached.

If the head restraint is adjustable, it shall be placed in the most unfavourable position allowed by its adjusting systems.
 - 1.2. Test apparatus
 - 1.2.1. This apparatus consists of a pendulum whose pivot is supported by ball-bearings and whose reduced mass* at its centre of percussion is 6.8 kg. The lower extremity of the pendulum consists of a rigid headform 165 mm in diameter whose centre is identical with the centre of percussion of the pendulum.
 - 1.2.2. The headform shall be fitted with two accelerometers and a speed-measuring device, all capable of measuring values in the direction of impact.
 - 1.3. Recording instruments

The recording instruments used shall be such that measurements can be made with the following degrees of accuracy:

 - 1.3.1. Acceleration:

Accuracy = ± 5 % of the actual value;

Frequency class of data channel: class 600 corresponding to ISO Standard 6487 (1980);

Cross-axis sensitivity = < 5 % of the lowest point on the scale.
 - 1.3.2. Speed:

Accuracy: ± 2.5 % of the actual value;

Sensitivity: 0.5 km/h.
 - 1.3.3. Time recording:

The instrumentation shall enable the action to be recorded throughout its duration and readings to be made to within one one-thousandth of a second;

* The relationship of the reduced mass "m_r" of the pendulum to the total mass "m" of the pendulum at a distance "a" between the centre of percussion and the axis of rotation and at a distance "l" between the centre of gravity and the axis of rotation is given by the formula:

$$m_r = m \frac{l}{a}$$

- The beginning of the impact at the moment of first contact between the headform and the item being tested shall be detected on the recordings used for analysing the test.
- 1.4. Test procedure
- 1.4.1. Tests on the seat-back
- With the seat installed as indicated in paragraph 1.1. of this annex, the direction of impact from the rear towards the front shall be situated in a longitudinal plane at an angle of 45° from the vertical.
- The impact points shall be selected by the test laboratory in area 1 as defined in paragraph 6.8.1.1. of this Regulation, or if necessary in area 2 as defined in paragraph 6.8.1.2. of this Regulation, on surfaces exhibiting radii of curvature less than 5 mm.
- 1.4.2. Tests on the head restraint from the rear
- The head restraint shall be fitted and adjusted as indicated in paragraph 1.1. of this annex. Impacts shall be performed on points selected by the test laboratory in area 1 as defined in paragraph 6.8.1.1. of this Regulation, and possibly in area 2 as defined in paragraph 6.8.1.2. of this Regulation, on surfaces exhibiting radii of curvature less than 5 mm.
- 1.4.2.1. For the front face, the direction of impact from the front towards the rear shall be horizontal in a longitudinal plane.
- 1.4.2.2. The front and rear zones are respectively bounded by the horizontal plane tangential to the top of the head restraint as determined in paragraph 6.5. of this UN Regulation.
- 1.4.3. The headform shall strike the test item at a speed of 24.1 km/h: this speed shall be achieved either by the mere energy of propulsion or by using an additional impelling device.
2. Results
- The deceleration rate shall be taken as the average of the readings on the two accelerometers.
3. Equivalent procedures (see paragraph 6.9. of this Regulation).

Annex 7

Method for testing the strength of seat anchorages and their adjustment, locking and displacement systems

1. Test of resistance to inertia effects
 - 1.1. The seats to be tested shall be mounted on the vehicle body for which they are designed. This vehicle body shall be firmly anchored on a test trolley as prescribed in the following paragraphs.
 - 1.2. The method used for anchoring the vehicle body on the test trolley shall not result in a reinforcement of the seat anchorages.
 - 1.3. The seats and their parts shall be adjusted and locked as prescribed in paragraph 6.1.1. and in one of the positions described in paragraph 6.3.3. or 6.3.4. of this Regulation.
 - 1.4. If the seats of a group do not present essential differences in the sense of paragraph 2.2. of this Regulation, the tests prescribed in paragraphs 6.3.1. and 6.3.2. of this Regulation may be carried out with one seat adjusted to its foremost position and the other seat adjusted to its rearmost position.
 - 1.5. The trolley deceleration or acceleration is measured with data channels of frequency class (CFC) 60 corresponding to the characteristics of International Standard ISO 6487 (2002).
2. Collision test of the complete vehicle against a rigid barrier
 - 2.1. The barrier shall consist of a block of reinforced concrete of not less than 3 m width, not less than 1.5 m height and not less than 0.6 m thickness. The front face shall be perpendicular to the final part of the run-up track and shall be covered with plywood boards 19 ∇ 1 mm thick. At least 90 tonnes of earth shall be compressed behind the block of reinforced concrete. The barrier of reinforced concrete and earth may be replaced by obstacles having the same front surface, provided that they give equivalent results.
 - 2.2. At the moment of impact the vehicle shall run free. It shall reach the obstacle on a course perpendicular to the collision wall; the maximum lateral misalignment allowed between the vertical median line of the front of the vehicle and the vertical median line of the collision wall shall be ∇ 30 cm; at the moment of impact the vehicle shall no longer be subjected to the action of any additional steering or propelling device. The speed on impact shall be between 48.3 km/h and 53.1 km/h.
 - 2.3. The fuel feed system shall be filled to at least 90 per cent of its capacity with fuel or an equivalent liquid.

Annex 8

Gap Measurement Test Procedure

1. Purpose

The purpose of this test procedure is to evaluate any gaps within head restraints as well as gaps between the bottom of the head restraint and the top of the seat back, in accordance with the requirements of paragraphs 5.6.4. and 5.6.5. of this Regulation.

Any gaps within the head restraint shall be measured using the sphere procedure described in paragraph 2. of this annex.

Gaps between the bottom of the head restraint and the top of the seat back shall be measured using the sphere procedure described in paragraph 2.1. to 2.5. of this annex below or, at the option of the manufacturer, using the linear procedure described in paragraph 3. of this annex.

2. Gap Measurement using a Sphere

2.1. The seat shall be adjusted such that its H-point coincides with the R-point; if the seat back is adjustable, it is set at the design seat back angle; both these adjustments shall be in accordance with the requirements of paragraph 2.1. of Annex 11.

2.2. The head restraint shall be adjusted to its lowest height position and any backset position intended for occupant use.

2.3. The area of measurement is anywhere between two vertical longitudinal planes passing at 85 mm on either side of the torso line and above the top of the seat back at a height greater than 540 mm.

2.4. Applying a load of no more than 5 N against the area of measurement specified in paragraph 2.2. above, place a 165 ± 2 mm diameter spherical headform against any gap such that at least two points of contact are made within the area.

2.5. Determine the gap dimension by measuring the straight line distance between the inner edges of the two furthest contact points, as shown in Figures 8-1, 8-2 and 8.3.

2.6. For gaps within the head restraint, if the measurement determined in paragraph 2.5 of this annex exceeding 60 mm, then in order to demonstrate compliance with the requirements of paragraph 5.6.4. of this Regulation, the seat back displacement test procedure described in Annex 5 shall be performed, by applying to each gap, using a sphere of 165 mm in diameter, a force passing through the centre of gravity of the smallest of the sections of the gap, along transversal planes parallel to the torso line, and reproducing a moment of 373 Nm about the R-point.

Figure 8-1
Measurement of a Vertical Gap "a"

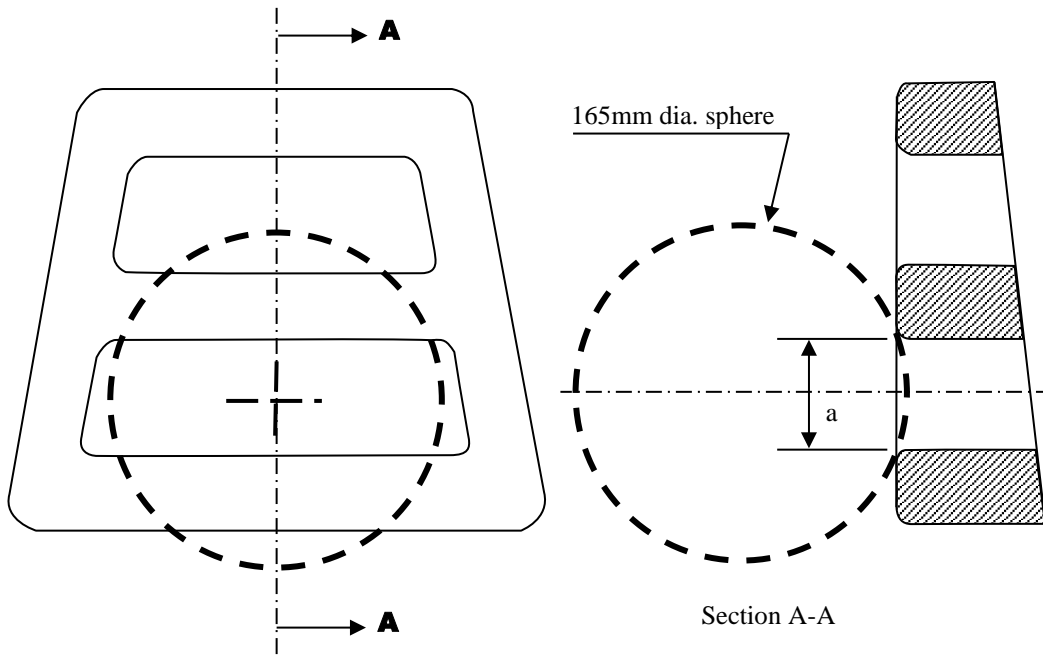

Note: Section A-A is to be made in a point of the gap area which allows the maximum sphere intrusion, without exerting any load.

Figure 8-2
Measurement of a Horizontal Gap "a".

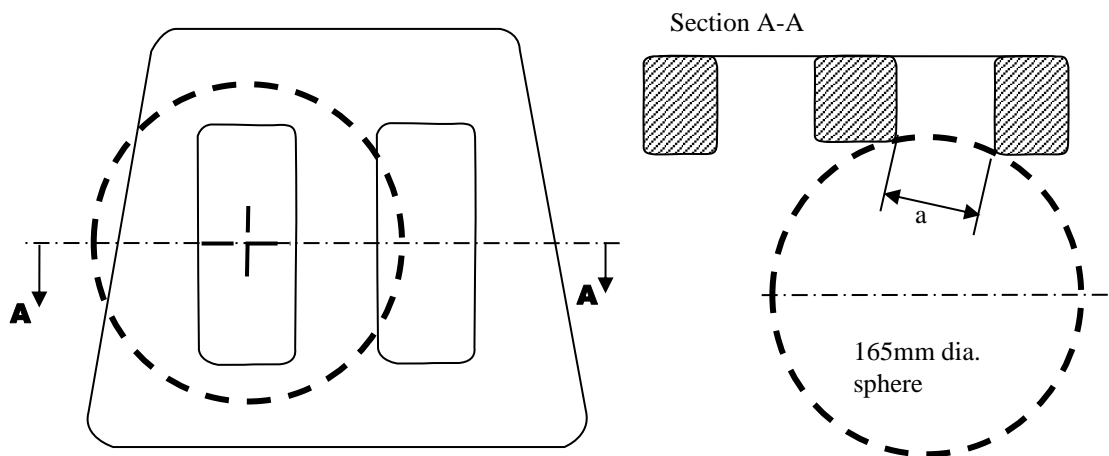

Note: Section A-A is to be made in a point of the gap area which allows the maximum sphere intrusion, without exerting any load.

Figure 8-3
Portion of Gap above 540mm

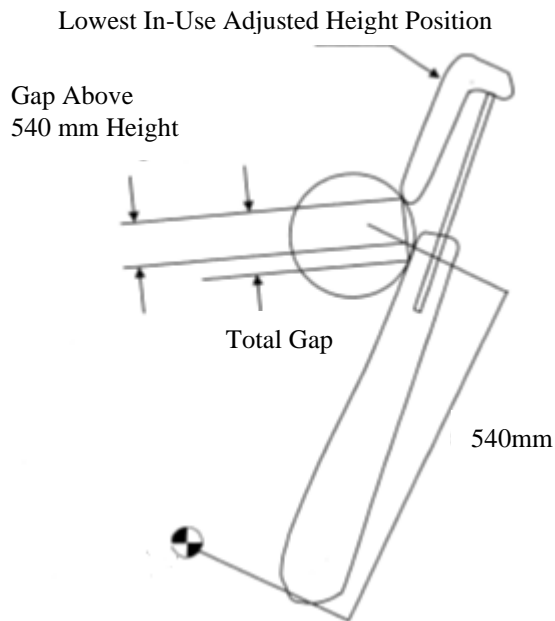

3. Linear Measurement of Gap
 - 3.1. The seat shall be adjusted such that its H-point coincides with the R-point; if the seat back is adjustable, it is set at the design seat back angle; both these adjustments shall be in accordance with the requirements of paragraph 2.1. of Annex 10.
 - 3.2. The head restraint shall be adjusted to its lowest height for normal occupant use and any backset position intended for occupant use.
 - 3.3. The gap shall be measured in the longitudinal vertical plane through the R-point as the perpendicular distance between two parallel planes, described as follows (see Figure 8-4):
 - (a) each plane shall be perpendicular to the design torso line;
 - (b) one of the planes shall be tangent to the bottom of the head restraint;
 - (c) the other plane shall be tangent to the top of the seat back.

Figure 8-4
Measurement Gap between Head Restraint and Top of the Seat Back

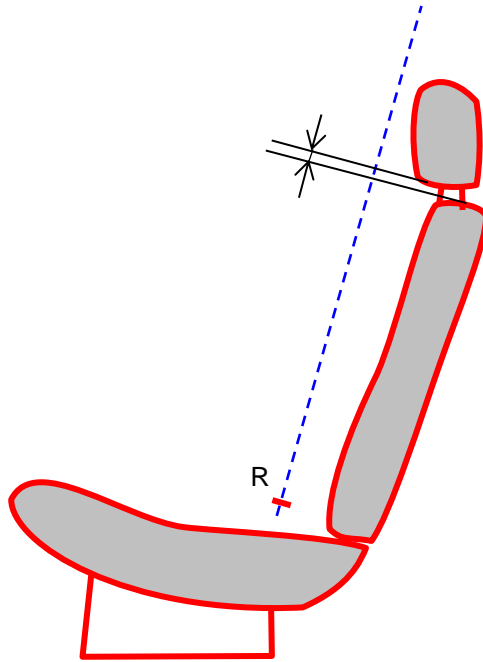

Annex 9

Test procedure for devices intended to protect the occupants against displacement of luggage

1. Test blocks

Rigid blocks, with the centre of inertia in the geometric centre.

Type 1

Dimensions: 300 mm x 300 mm x 300 mm

All edges and corners rounded to 20 mm

Mass: 18 kg

Moment of inertia $0.3 \pm 0.05 \text{ kgm}^2$ (around all 3 principal axis of inertia of the luggage blocks)

Type 2

Dimensions: 500 mm x 350 mm x 125 mm
all edges and corners rounded to 20 mm

Mass: 10 kg
2. Test preparation
 - 2.1. Test of seat-backs (see Figure 1)
 - 2.1.1. General requirements
 - 2.1.1.1. At the option of the car manufacturer, parts whose hardness is lower than 50 Shore A can be removed from the tested seat and head restraint for the tests.
 - 2.1.1.2. Two type 1 test blocks shall be placed on the floor of the luggage compartment. In order to determine the location of the test blocks in the longitudinal direction, they shall first be positioned such that their front side contacts that part of the vehicle which constitutes the forward boundary of the luggage compartment and that their lower side rests on the floor of the luggage compartment. They shall then be moved backwards and parallel to the longitudinal median plane of the vehicle until their geometrical centre has traversed a horizontal distance of 200 mm. If the dimensions of the luggage compartment do not allow a distance of 200 mm and if the rear seats are horizontally adjustable, these seats shall be moved forward to the limit of the adjustment range intended for normal occupant use, or to the position resulting in a distance of 200 mm, whichever is less. In other cases, the test blocks shall be placed as far as possible behind the rear seats. The distance between the longitudinal median plane of the vehicle and the inward facing side of each test block shall be 25 mm to obtain a distance of 50 mm between both blocks.
 - 2.1.1.3. During the test, the seats shall be adjusted to ensure that the locking system cannot be released by external factors. If applicable, the seats shall be adjusted as follows:

The longitudinal adjustment shall be secured one notch or 10 mm in front of the rearmost possible position of use specified by the manufacturer (for seats with independent vertical adjustment, the cushion shall be placed to its lowest possible position). The test shall be carried out with the seat-backs in their normal position of use.
 - 2.1.1.4. If the seat-back is fitted with a head restraint, the test shall be carried out with the head restraint placed in the highest position, if adjustable.

- 2.1.1.5. If the back(s) of the rear seat(s) can be folded down, they shall be secured in their upright normal position by the standard locking mechanism.
- 2.1.1.6. Seats behind which the type 1 blocks cannot be installed are exempted from this test
- 2.1.1.7. All seating positions of the seat row under test shall be fitted with all components of its safety-belt providing the restraining function that are part of the seat.

Figure 1

Positions of test blocks before test of rear seat-backs

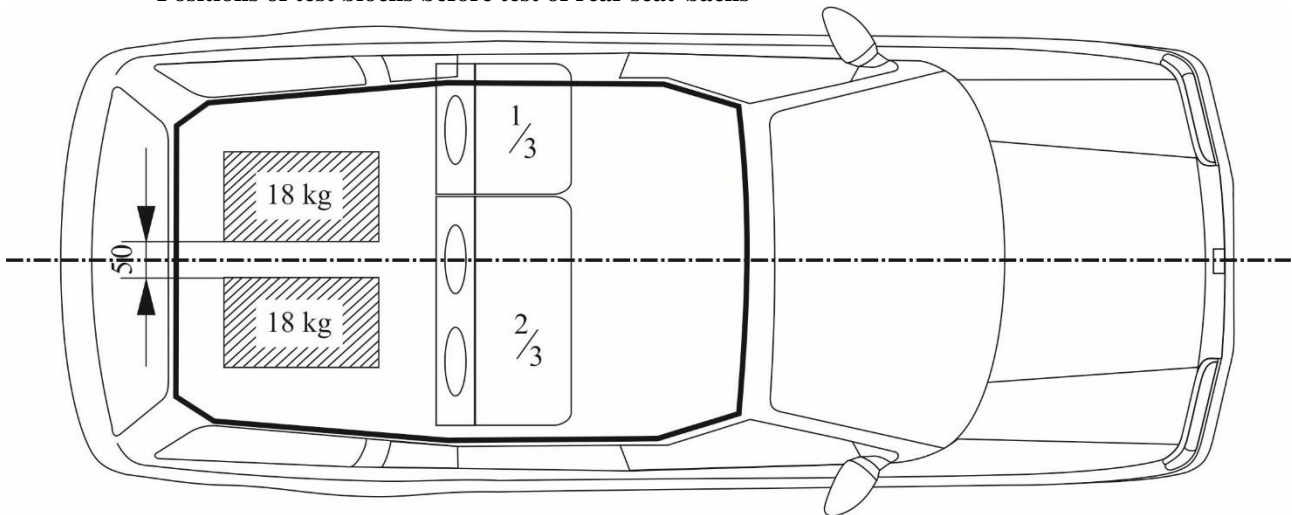

- 2.1.2. Vehicles with more than two rows of seats
- 2.1.2.1. If the rearmost row of seats is removable and/or can be folded down by the user according to the manufacturer's instructions in order to increase the luggage compartment area, then the seat row immediately in front of this rearmost row shall also be tested.
- 2.1.2.2. However, in this case, the Technical Service, after consultation with the manufacturer, may decide not to test one of the two rearmost rows of seats if the seats and their attachments are of similar design and if the test requirement of 200 mm is respected.
- 2.1.3. When there is a gap, allowing sliding of one type 1 block past the seats, then the test loads (two type 1 blocks) shall be installed behind the seats after agreement between the Technical Service and the manufacturer.
- 2.1.4. The exact test configuration shall be noted in the test report.
- 2.2. Test of partitioning systems

For the test of the partitioning systems above the seat-backs, the vehicle shall be fitted with a fixed raised test floor having a load surface that locates the centre of gravity of the test block centrally between the top edge of the bordering seat-back (without taking into account the head restraints) and the bottom edge of the roof lining. A type 2 test block is placed on the raised test floor with its largest surface 500 x 350 mm, centrally in relation to the longitudinal axis of the vehicle and with its surface 500 x 125 mm to the front. Partitioning systems behind which the type 2 test block cannot be installed are exempted from this test. The test block is placed directly in contact with the partitioning system. In addition, two type 1 test blocks are positioned in accordance with paragraph 2.1. in order to perform a simultaneous test on the seat-backs (see Figure 2).

Figure 2
Testing of a partitioning system above the backrest
edge of interior roof

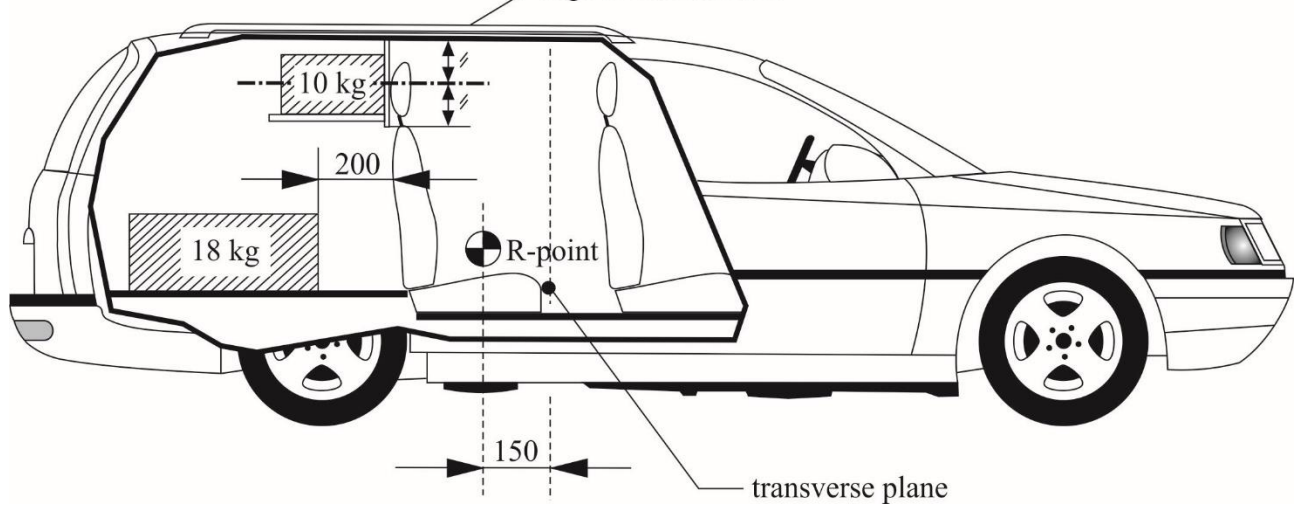

- 2.2.1. If the seat-back is fitted with a head restraint, the test shall be carried out with the head restraint placed in the highest position, if adjustable.
3. Dynamic testing of seat-backs and partitioning systems used as luggage restraint systems
 - 3.1. The body of the passenger car shall be anchored securely to a test sled, and this anchorage shall not act as reinforcement for seat-backs and the partitioning system. After the installation of the test blocks as described in paragraph 2.1. or 2.2., the passenger car body shall be decelerated or, at the choice of the applicant, accelerated such that the curve remains within the area of the graph as shown in the Annex 9, Appendix, and the total velocity change ΔV is 50 ± 2 km/h. With the agreement of the manufacturer, the above described test pulse corridor can be used alternatively to fulfil the test of the seat strength according to paragraph 6.3.1. of this Regulation.

Annex 9 - Appendix

Corridor of sled's deceleration or acceleration as a function of time

(Simulation of frontal impact)

Figure 9-3

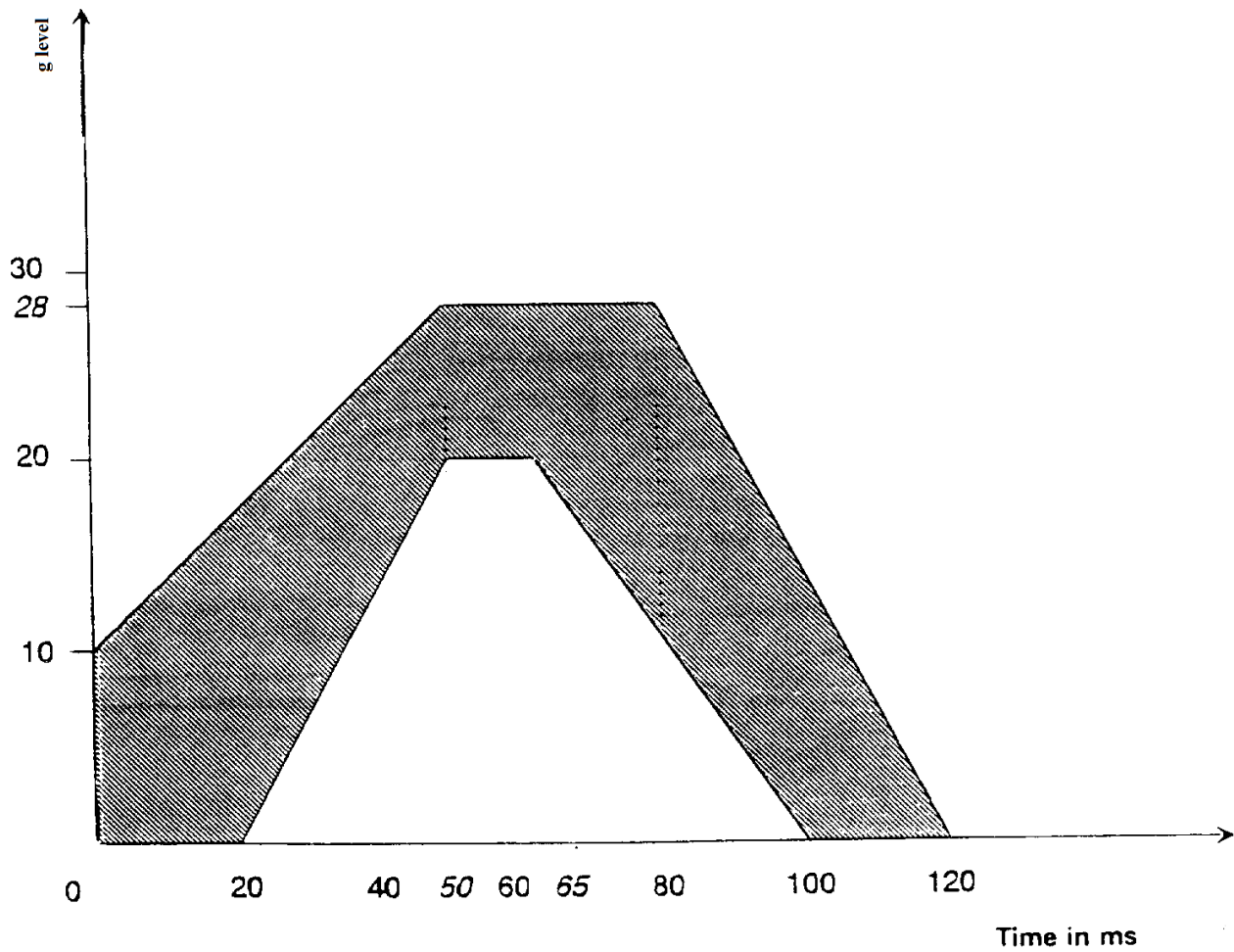

Annex 10

Height Measurement Test Procedure

1. Purpose
The purpose of this test procedure is to demonstrate compliance with the height requirements described in paragraph 5.6.2. of this Regulation.
2. Procedure for Height Measurement
Compliance with the requirements of paragraph 5.6.2. of this Regulation shall be demonstrated by using the height measurement procedure defined in paragraph 2.2. and 2.3. of this annex.
 - 2.1. Relationship between the H-point and the R-point
The seat is adjusted such that its H-point coincides with the R-point; if the seat back is adjustable, it is at the seat back inclination corresponding to the design torso angle; the relationship between the H-point and the R-point shall be in accordance with the requirements of paragraph 2.1.1. of Annex 11.

If, elsewhere during head restraint testing, the H-point and actual torso angle have been found in accordance with paragraph 2.1.1. of Annex 11, the check on the relationship does not need to be repeated for the height measurement test procedure of this annex.

Alternative:

If, elsewhere during head restraint testing, the H-point and/or actual torso angle have not been found in accordance with Annex 11 paragraph 2.1.1., but consequently paragraph 2.1.3. or paragraph 2.1.4. of Annex 11 have been applied, then the check on the relationship shall not be repeated for the height measurement.
 - 2.2. Height measuring apparatus
The height measurement is based on the use of an apparatus that facilitate the measurement of coordinates.
 - 2.3. Height measurement
All measurements shall be taken in the median longitudinal plane of the designated seating position.
 - 2.3.1. Determination of contact point (CP) (see Figure 10-1)
Adjust the head restraint to the position intended for use by the mid-sized male¹, as specified by the manufacturer. In the absence of any specification, the head restraint shall be adjusted as close as possible to the mid-position. If two positions of adjustment are equidistant from the mid-position, the head restraint shall be adjusted to the higher of the mid-position and/or rear of the mid-position.

For head restraints not adjustable for height, the fixed position shall be used.

If there is only one in-use position, this shall be treated as a head restraint which is not adjustable for height.

¹ The back-of-head of the mid-sized male is represented by the HRMD attached to the three-dimensional H-point machine, as well as by the Torso & Neck Link with the head room probe fitted 71 mm rearwards (see Figure 10-1).

The CP is defined as the intersection of a horizontal line, on the height of the Z-coordinate of the back-of-head of the mid-sized male (as given in Table 10-1), with the front surface of the head restraint as indicated in Figure 10-1.

Once established, the point CP is a virtual seat reference point (x and z coordinates).

Where CP cannot be determined because the horizontal line through the back-of-head of the mid-sized male is located above the head restraint, the head restraint must be raised to the next locking position to enable the determination of point CP.

In the instance where this will not produce a point of intersection, the CP will be designated at the horizontal top of the head [restraint].

The horizontal top of the head restraint being defined as the uppermost point on the head restraint, which is determined by lowering a horizontal line in the median longitudinal plane of the designated seating position until it touches the head restraint (see Figure 10-4).

Where more points are located at the same height, the longitudinally forward most point of the horizontal top of the head restraint is designated as CP.

Note: This paragraph 2.3.1. describes only CP.

Where CP cannot be determined because the horizontal line through the back-of-head of the mid-sized male is on the level of a gap within the head restraint, CP will be determined using a 165 mm diameter sphere with its centre at the same height level as the horizontal line through the back-of-head of the mid-sized male.

When the sphere is making first contact with the head restraint, CP is designated as the rearmost point of the sphere in the gap area (see Figure 10-5).

2.3.2. Determination of intersection point (IP)

Adjust the head restraint to the uppermost position. If the head restraint is tiltable or adjustable fore-and-aft, the tilt and fore-and-aft adjustment used for the determination of CP will be kept.

The IP is determined on the front surface of the head restraint as the intersection with a vertical line rearwards of CP (see Figure 10-2) at the "distance x" (as given in Table 10-1).

Where IP would be located rearwards of the horizontal top of the head restraint, IP will be designated at the horizontal top of the head restraint (see Figure 10-4).

Note: consider all references to "horizontal top" for similar solution.

Where the CP is designated at the horizontal top of the head restraint in paragraph 2.3.1., and there is no existing point of IP on the head restraint surface, the IP is also designated on the horizontal top of the head restraint as determined in accordance with paragraph 2.3.1. of this annex.

The determined point "IP" will be kept in any adjustment position.

For head restraints not adjustable for height, IP is to be determined in the fixed position.

Table 10-1

Head position table

Location of the back-of-head of two designated males in automotive posture with respect to the R-point at several design torso angles, and their in-between "distance x"

Design torso angle	X-coordinate of back-of-head calculated for the mid-sized male	Z-coordinate of back-of-head calculated for the mid-sized male	X-coordinate of back-of-head calculated for large male ²	"Distance x": distance between X-coordinates of back-of-head of both males
	$504.5 * \sin(\text{design torso angle} - 2.6) + 71$	$504.5 * \cos(\text{design torso angle} - 2.6) + 203$	$593 * \sin(\text{design torso angle} - 2.6) + 76$	$88.5 * \sin(\text{design torso angle} - 2.6) + 5$
5	92	707	101	9
6	101	707	111	10
7	110	706	121	12
8	118	705	132	13
9	127	704	142	15
10	136	703	152	16
11	145	702	163	18
12	153	701	173	19
13	162	699	183	21
14	171	698	193	22
15	179	696	203	24
16	188	694	213	26
17	196	692	223	27
18	205	689	233	29
19	213	687	243	30
20	222	684	253	31
21	230	682	263	33
22	239	679	273	34
23	247	676	283	36
24	255	673	292	37
25	263	669	302	39
26	271	666	312	40
27	279	662	321	42
28	287	659	330	43
29	295	655	340	44
30	303	651	349	46

² The large male is represented by a virtually up scaled Torso & Neck Link; where the mid-sized male version of the Torso and Neck Link measures 504.5 mm and 203 mm with the head room probe 71 mm rearwards, the up scaled version for the large male measures respectively 593 mm and 219 mm with the head room probe 76 mm rearwards.

2.3.3. Determination of the highest head restraint height

The head restraint height is the distance from the R-point, parallel to the torso reference line and limited by a line perpendicular to the torso reference line intersecting IP (see Figure 10-3).

After the coordinates of IP are determined, the highest head restraint height can be calculated by its longitudinal (ΔX) and vertical (ΔZ) distance from the R-point (see Figure 10-3), as follows:

Head restraint height =

$$\Delta X \cdot \text{SIN}(\text{design torso angle}) + \Delta Z \cdot \text{COS}(\text{design torso angle})$$

- 2.3.3.1. Determination of the highest head restraint height in case of exception according paragraph 5.6.2.3. and 5.6.2.5.

Adjust the head restraint to its highest position intended for occupant use and measure the clearance between the highest point on the centre line of the head restraint and the interior surface of the roofline or the rear backlight, by attempting to pass a 50 ± 0.5 mm sphere, between them.

- 2.3.4. Determination of the lowest head restraint height

Adjust the head restraint to the lowest position of adjustment intended for normal use other than any non-use position described in paragraph 5.8. of this Regulation.

In this lowest in-use position, the head restraint height is the distance from the R-point, parallel to the torso reference line and limited by a line perpendicular to the torso reference line intersecting the point IP (the IP was determined for the highest head restraint height in paragraph 2.3.3.).

Figure 10-1

Goniometry in the test procedure using apparatus that facilitate the measurement of coordinates

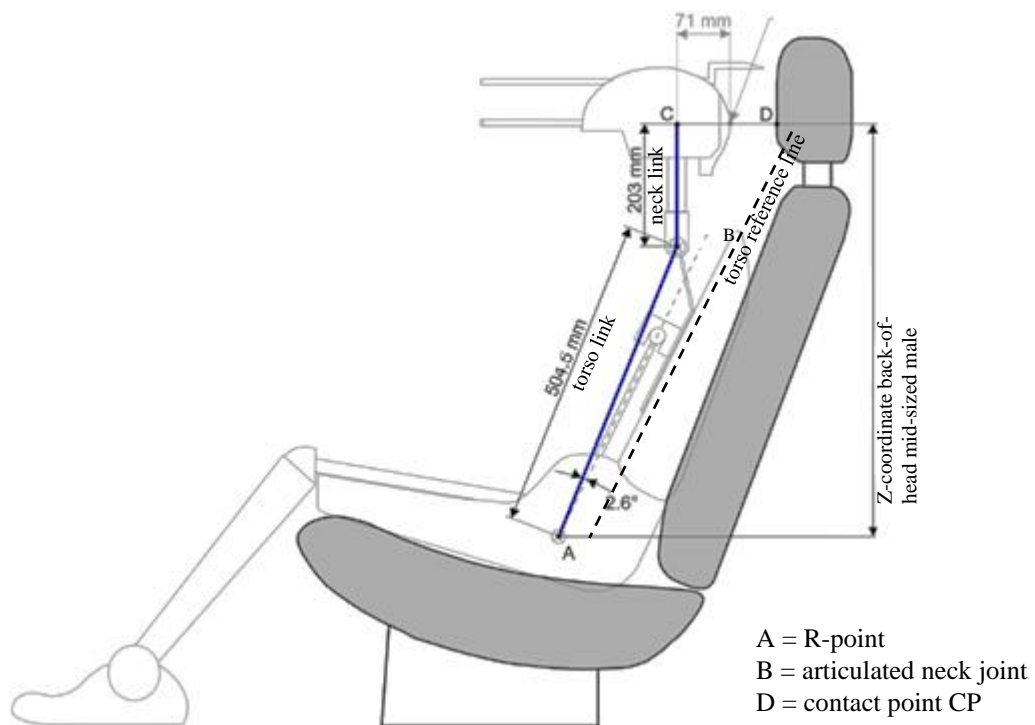

The H-point machine are only shown to explain the concept but are not needed for this test procedure.

Figure 10-2

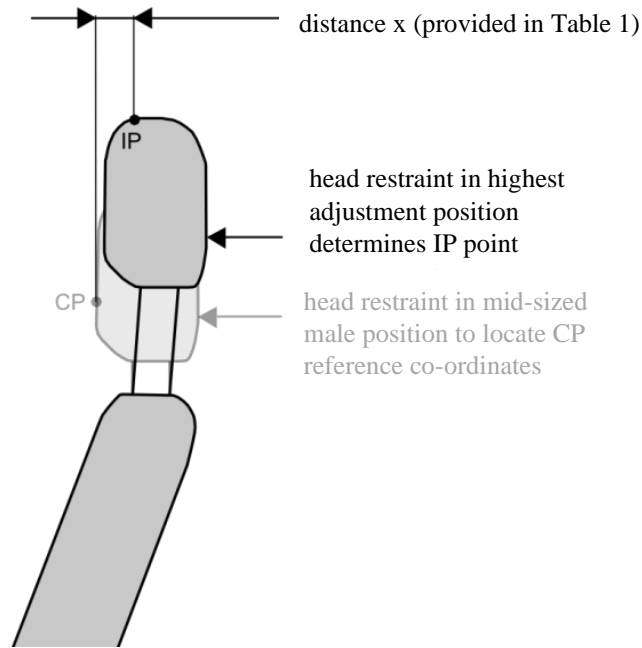

Figure 10-3

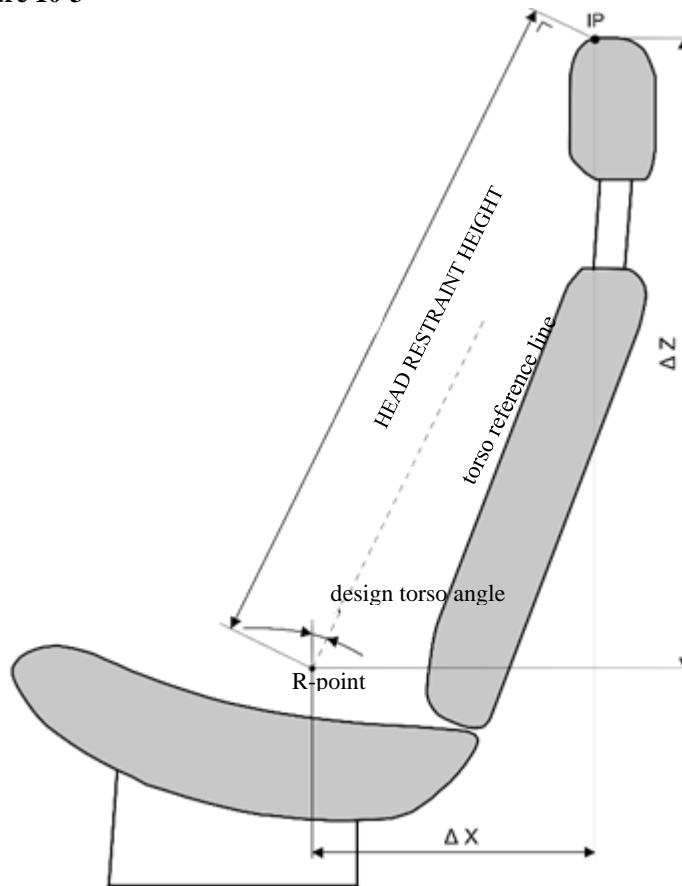

Figure 10-4

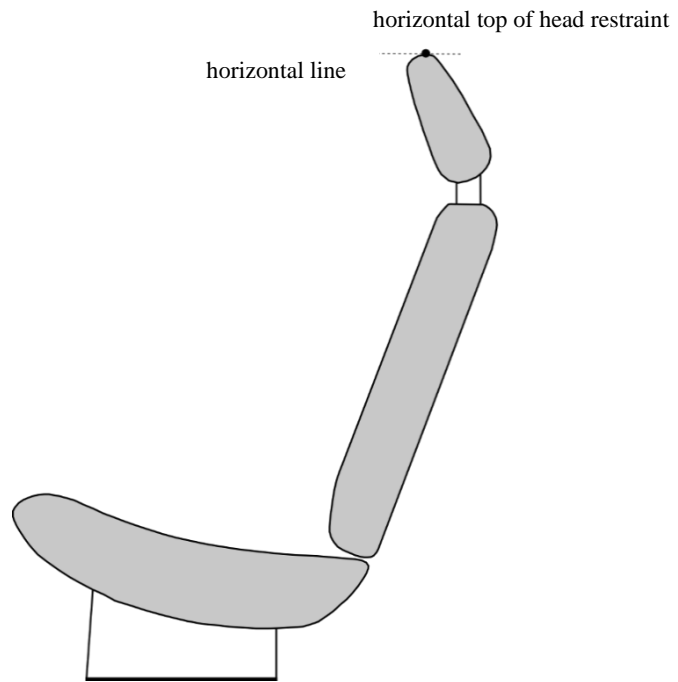

Figure 10-5

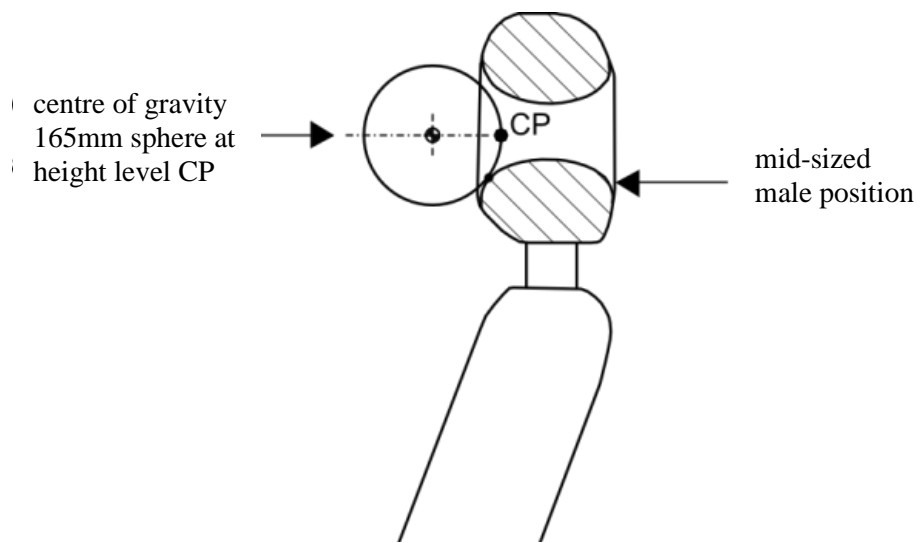
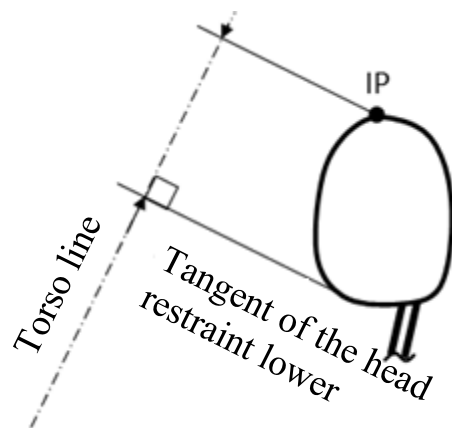

Figure 10-6



Annex 11

Backset Measurement Test Procedure

1. Purpose
Demonstrate compliance with paragraph 5.6.6. by measuring the backset using the R-point as the reference point.
2. Procedure for backset measurement using R-point as the reference point
Demonstrate compliance with paragraph 5.6.6. by measuring the R-point backset of the head restraint based on the usage of apparatus that facilitates the measurement of coordinates and for its dimensions is based on Figure 10-2 of Annex 10.
 - 2.1. Adjust the seat such that its H-point coincides with the R-point, in accordance with the following requirements.
 - 2.1.1. Relationship between the H-point and the R-point
When the seat is positioned in accordance to the manufacturer's specifications, following the procedure of Annex 3. the H-point, as defined by its co-ordinates, shall lie within a square of 50 mm side length with horizontal and vertical sides whose diagonals intersect at the R-point, and the actual torso angle is within 5 ° of the design torso angle.
 - 2.1.2. If these conditions are met, the R-point and the design torso angle are used to demonstrate compliance with the provisions of paragraph 5.6.6. of this Regulation.
 - 2.1.3. If the H-point or the actual torso angle do not satisfy the requirements of paragraph 2.1.1., the H-point and the actual torso angle are determined twice more (three times in all). If the results of two of these three operations satisfy the requirements, the conditions of paragraph 2.1.2. shall apply.
 - 2.1.4. If the results of at least two of the three operations described in paragraph 2.1.3. do not satisfy the requirements of paragraph 2.1.1. the centroid of the three measured points or the average of the three measured angles is used and shall be regarded as applicable in all cases where the R-point or the design torso angle is referred to in this annex.
 - 2.2. Adjust the seat back to its design angle.
 - 2.3. Adjust the front head restraint so that its point IP is at any height between and inclusive of 720 mm and 830 mm of paragraph of 5.6.2.1. of this Regulation, measured as described in Annex 10. If the lowest position of adjustment is above 830 mm, adjust the head restraint to that lowest position of adjustment.
 - 2.4. In the case of head restraint with adjustable backset, adjust the head restraint at the most rearward position, such that the backset is in the maximum position.
 - 2.5. Establish point D on the head restraint, point D being the intersection of a line drawn from point C horizontally in the x-direction, with the front surface of the head restraint, see Figure 10-1 of Annex 10.
 - 2.6. Measure the X-coordinate of point D. The R-point backset is the difference between the X-coordinate of point D and the X-coordinate of the back-of-head of the mid-size male as given in Table 10-1 of Annex 10.

Annex 12

Energy Absorption Test Procedure for Head Restraint from the Front

1. Purpose
Evaluate the energy absorption ability of the head restraint by demonstrating compliance with paragraph 5.7.1. of this Regulation in accordance with this annex.
2. Seat Set-Up
The seat shall be either mounted in the vehicle or firmly secured to the test bench, as mounted in the vehicle with the attachment parts provided by the manufacturer, so as to remain stationary when the impact is applied. The seat back is adjusted as specified in paragraph 6.1.1. of the Regulation. The head restraint shall be mounted on the seat-back as in the vehicle. Where the head restraint is separate, it shall be secured to the part of the vehicle structure to which it is normally attached.
 - 2.1. The front zones are respectively bounded by the horizontal plane tangential to the top of the head restraint as determined in paragraph 6.5. of this Regulation.
3. Procedure for Energy Absorption
Adjustable head restraints shall be measured in any height and backset position of adjustment.
 - 3.1. Test equipment.
 - 3.1.1. Use an impactor with a semispherical headform of a 165 ± 2 mm diameter. The headform and associated base have a combined mass such that at a speed of 24.1 km/h at the time of impact an energy of 152 Joule will be reached.
 - 3.1.2. Instrument the impactor with an acceleration sensing device whose output is recorded in a data channel that conforms to the requirements for a 600 Hz channel class filter as specified in ISO Standard 6487 (2002). The axis of the acceleration-sensing device coincides with the geometric centre of the headform and the direction of impact. As an alternative the impactor can be equipped with two accelerometers sensing in the direction of impact and placed symmetrically in comparison to the geometric centre of the spherical headform. In this case the deceleration rate shall be taken as the simultaneous average of the readings on the two accelerometers.
 - 3.2. Accuracy of the test equipment.
The recording instruments used shall be such that measurements can be made with the following degrees of accuracy:
 - 3.2.1. Acceleration:
Accuracy = ± 5 per cent of the actual value;
Cross-axis sensitivity = < 5 per cent of the lowest point on the scale.
 - 3.2.2. Speed:
Accuracy: ± 2.5 per cent of the actual value;
Sensitivity: 0.5 km/h.
 - 3.2.3. Time recording
The instrumentation shall enable the action to be recorded throughout its duration and readings to be made to within one one-thousandth of a second;

The beginning of the impact at the moment of first contact between the headform and the item being tested shall be detected on the recordings used for analysing the test.

- 3.3. Test procedure
- 3.3.1. Propel the impactor toward the head restraint. At the time of impact, the longitudinal axis of the impactor is within $\pm 2^\circ$ of being horizontal and parallel to the vehicle longitudinal axis and the impactor speed shall be 24.1 km/h.
- 3.3.2. Impact the front surface of the seat or head restraint at any point with a height greater than 635 mm from the R-point and within a lateral distance from the head restraint vertical centreline of 70 mm and measure the acceleration.

Annex 13

Height Retention Test Procedure

1. Purpose
Demonstrate compliance with the height retention requirements of paragraph 5.7.4. of this Regulation in accordance with this annex.
2. Procedures for Height Retention
 - 2.1. Seat set-up
Adjust the adjustable head restraint so that its effective top is at any of the following height positions at any backset position:
 - 2.1.1. For front outboard designated seating positions:
 - 2.1.1.1. The highest position; and
 - 2.1.1.2. Not less than, but closest to 830 mm;
 - 2.1.2. For rear outboard and front centre designated seating positions:
 - 2.1.2.1. The highest position; and
 - 2.1.2.2. Not less than, but closest to 720 mm.
 - 2.1.3. For rear centre designated seating positions:
 - 2.1.3.1. The highest position; and
 - 2.1.3.2. Not less than, but closest to 700 mm.
 - 2.2. Orient a cylindrical test device having a 165 ± 2 mm diameter in plane view (perpendicular to the axis of revolution), and a 152 ± 2 mm length in profile (through the axis of revolution) such that the axis of the revolution is horizontal and in the longitudinal vertical plane through the vertical longitudinal zero plane of the head restraint. Position the midpoint of the bottom surface of the cylinder in contact with the head restraint.
 - 2.3. Establish initial reference position by applying a vertical downward load of 50 ± 1 N at a rate of 250 ± 50 N/minute. Determine the reference position of the cylinder after five seconds at this load. Mark the initial reference position for the head restraint.
 - 2.4. Measure the vertical distance between the lowest point on the underside of the head restraint and the top of the seat back (see paragraph 2.9. of this annex).
 - 2.5. Increase the load at the rate of 250 ± 50 N/minute to at least 500 N and maintain this load for not less than five seconds.
 - 2.6. Reduce the load at a rate of 250 ± 50 N/m until the load is completely removed. Maintain this condition for no more than two minutes. Increase the load at a rate of 250 ± 50 N/minute to 50 ± 1 N and, after five seconds and while maintaining this load, determine the position of the cylindrical device with respect to its initial reference position.
 - 2.7. Repeat the measurement of the vertical distance measured between the lowest point on the underside of the head restraint and the top of the seat back. (see paragraph 2.9. of this annex)
 - 2.8. Compare the measurements from paragraphs 2.4. and 2.7. of this annex. The difference is the measurement required to comply with paragraph 5.7.4. of the Regulation.

- 2.9. If the design of the head restraint is such that it is not possible to measure to the top of the seat then the vertical measurement shall be taken by marking a horizontal line across the front of the seat back at least 25 mm below the lowest point of the head restraint and the measurement shall be taken from this line to the underside of the head restraint.
- 2.10. Alternatively, when the manufacturer demonstrates that the difference of the reference positions of the cylinder measured in paragraphs 2.3. and 2.6. of this annex is smaller than the value required by paragraph 5.7.4. of the Regulation, then the test result will also comply to paragraph 5.7.4. of the Regulation. In this case measurements of paragraphs 2.4. and 2.7. do not need to be recorded.

Annex 14

Dynamic Performance Test Procedure

1. Purpose

Demonstrate compliance with paragraph 5.9. in accordance with this annex, using a 50th percentile male BioRID II UN, test dummy.
2. Test Equipment
 - 2.1. An acceleration test sled
 - 2.2. 50th percentile male test dummy
 - 2.2.1. BioRID II UN
 - 2.2.1.1. Conforming to Addendum 1 to the Mutual Resolution M.R.1 (ECE/TRANS/WP.29/1101/Add.1)
 - 2.2.2. Equipment for measuring and recording sled accelerations.
3. Procedures for Test Set-Up
 - 3.1. The setup of Seat and Dummy on the Sled.
 - 3.1.1. An acceleration sled with the dummy seated facing the direction of motion shall be used. Sled accelerations shall be measured by an appropriate accelerometer attached to the sled platform

The temperature in the test laboratory shall be $22.5^{\circ} \pm 3^{\circ}\text{C}$ with a relative humidity of between 10 per cent and 70 per cent. The test dummy and seat being tested shall be soaked at this temperature for at least 3 hours prior to the test.

All tests shall be performed with the active elements of the system designed to operate during rear impact set to their operation condition (e.g. Active head restraint, Seat belt pre-tensioner). The time to fire (TTF) required for a specific elements of the active head restraint shall be specified by the vehicle manufacturer.
 - 3.1.2. Acceleration Sled
 - 3.1.2.1. The parts of the vehicle structure considered essential for the replication of the vehicle rigidity regarding the seat, its anchorages, the safety-belt anchorages and the head restraints shall be secured to the sled.

It shall be so constructed that no permanent deformation appears after the test. Where the upper anchorage has an adjustable height position, it shall be set nearest to the mid-range position permitted by the design
 - 3.1.2.2. The sled shall be capable of accommodating, in an appropriate manner, such equipment as may be specified by the manufacturer as necessary for the correct functioning of advanced head restraint systems (active head restraints).
 - 3.1.2.3. A toe board comprising a horizontal section and a forward facing section oriented at 45° from the horizontal shall be provided.
 - 3.1.2.4. Some sled motion is allowed at the initiation of the test ($T=0$) however, the dummy's head, T1 vertebra, and the sled should have the same velocity $\pm 0.1\text{m/s}$ at $T=0$. The back of the dummy's head and T1 vertebra should be in the same position ($\pm 5\text{mm}$) relative to the head restraint at $T=0$ as the initial test set-up.
 - 3.1.3. Mounting the Seat on the Sled.

- 3.1.3.1. Mount the seat, including all of its adjustment mechanisms and hardware that normally connects it to the vehicle floor on the sled platform so that the seat's orientation relative to the horizontal is the same as it would be in the vehicle. The gap between the front of the seat and rear of the toe board shall be no more than 100 mm. Instrument the platform with an accelerometer mounted such that its sensitive axis is parallel to the direction of test platform travel.
- 3.1.4. Seat Adjustment.
- 3.1.4.1. The seat shall be set as specified by the manufacturer, with regard to both the design position of the seat back (see paragraph 2.21. of this Regulation) and the position of the seat itself. This position shall be the one where the H-point coincides with R50 point.
- In the absence of any specification declared by the manufacturer, the procedures of paragraphs 3.1.4.2. to 3.1.4.5. shall apply.
- 3.1.4.2. Where no adjustment is specified, the seat shall be adjusted to its mid-position in both the horizontal and vertical directions.
- If an adjustment position does not exist midway between those positions, place the seat midway between the most forward and most rearward position. The closest adjustment position to the rear of the midpoint shall be used.
- 3.1.4.3. Where no cushion adjustment is specified, and where the seat cushion is adjustable independently of the seat back, adjust the seat cushion inclination to its mid-position. All other cushion adjustments shall be in a fully retracted position, with the exception of cushion side bolsters which shall be set to their widest position.
- 3.1.4.4. Any adjustable lumbar supports shall be positioned so that the lumbar support is in its lowest retracted or deflated position. Arm rests shall be set in the stowed position.
- 3.1.4.5. Any other seat adjustment device must be set in its most retracted or deflated position.
- 3.1.4.6. Where no design torso angle is specified and where the seat back is adjustable, it shall be set at a torso angle closest to $25^{\circ} \pm 1^{\circ}$ from the vertical, as measured using the three-dimensional H-point machine, as specified in Annex 3. If there is more than one inclination position close to a torso angle of 25° then it shall be set to the position closest to and rearward of 25° .
- 3.1.5. Head Restraint Adjustment
- 3.1.5.1. If the head restraint adjusts automatically, the adjustments from paragraphs 3.1.4.1. to 3.1.4.6. shall apply.
- 3.1.5.2. Adjust the head restraint to the position intended for use by the 50th percentile male, as specified by the manufacturer. If not available adjust the head restraint in the midway between the lowest and the highest position and follow the paragraph 3.1.5.2.2. of this annex.
- 3.1.5.2.1. Where the adjustment of the head restraint is not automatic, it shall be set in accordance with the manufacturer's specification.
- 3.1.5.2.2. If a locking position midway between the lowest and the highest position does not exist, adjust the head restraint to the position determined by the paragraphs below.
- A locking position exists within 10 mm vertically upwards from the geometric mid-position, this shall be the test position. If no locking position exists within 10 mm vertically upwards from the geometric mid-position then the next locking position down shall be the test position. This shall be determined from the top of the head restraint.

Figure 14-1

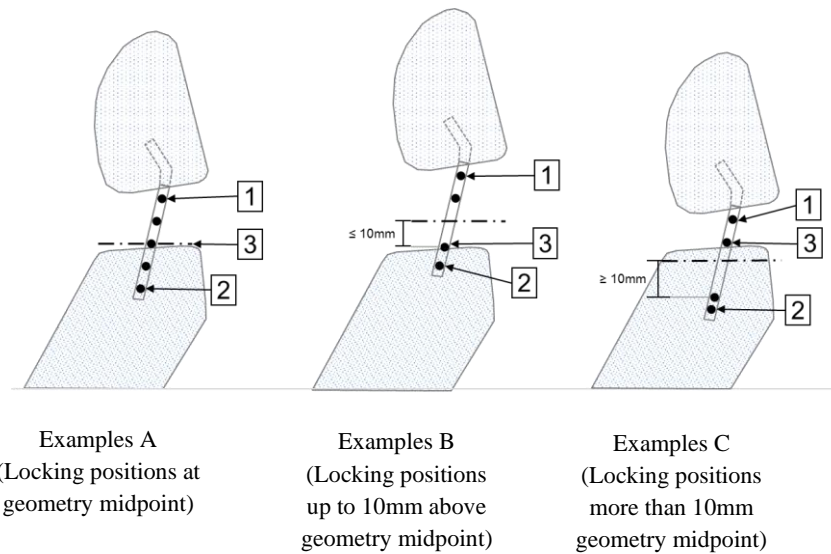

- 1 : Head Restraint in lowermost position.
- 2 : Head Restraint in uppermost position.
- 3 : Test Position.
- · — Horizontal mid-position between lowermost and uppermost position of the Head Restraint.

When the head restraint has a locking fore-aft adjustment, it shall be in the midpoint. If a locking position exists within 10 mm horizontally forward from the geometric mid-position, this shall be the test position. If no locking position exists within 10 mm horizontally forwards from the geometric mid-position then the next locking position rearwards shall be the test position, as shown in Figure 14.1.

If no fore-aft locking positions are available for the head restraint it shall be tilted fully rearward.

3.1.6. BioRID II UN Reference measurement

3.1.6.1. Using the 3D-H measuring machine, check that the H-point coincides with the R50 point, in accordance with the following requirements.

The procedure set out in Annex 3 shall be used to verify the H-point relationship to the R50 point specified by the manufacturer.

The relative positions of the R-point and the H-point relationship shall be considered satisfactory for the seating position in question if the actual "H"-point, lies within a square of 50 mm side length with horizontal and vertical sides F whose diagonals intersect at the R50 point, and the actual torso angle is within 5° of the design torso angle.

3.1.6.2. Back of the head reference position

The back of the head reference position for the UN BioRID II is the value for the back of the head as determined for the 50th percentile in Table 10-1 of Annex 10 of this Regulation with reference to the specified torso angle minus 15 mm (increasing the backset as shown in figure-14-2 below).

Where no design torso angle is specified, set the angle as specified in paragraph 3.1.4.6. Both the measured H-point and angle shall be used when referencing Table 10-1, Annex 10.

- 3.1.7. Dummy Installation
- 3.1.7.1. The dummy's clothing shall comprise two pairs of shorts and two shirts made of a nylon fabric. The fabric has a different texture on the outside as it does on the inside – shiny and matt. The dummy shall be dressed with both sets of clothing so that the shiny sides of the materials come face to face with each other. Shoes are men's dress oxford type, US size 11 (European size 45) extra wide that meet military specifications MIL-S-13192P. Each shoe weight 0.57 ± 0.1 kg and has an overall length of 320-325mm.
- 3.1.7.2. The seat shall be in an unloaded condition for at least 15 minutes before installing the dummy.
- 3.1.7.3. The appropriate lifting tools and the attachment points recommended by the dummy manufacturer shall be used to position the dummy in the seat. The dummy shall initially be installed with its H-point rearward of the target H-point and the pelvis only moved forward to achieve the position indicated in paragraph 3.1.7.6. below. In the event that the dummy is moved forward of the specified target H-point the dummy shall be removed from the seat and the complete installation procedure repeated. It is not permissible to push the pelvis rearward to bring the pelvis H-point into line with the specified H-point position.
- 3.1.7.4. Adjust the test dummy's midsagittal plane to be vertical and aligned with the centreline of the seat. The instrumentation platform in the head shall be laterally level within $\pm 0.5^\circ$.
- 3.1.7.5. Adjust the pelvis angle to the actual torso angle recorded by the procedure specified in paragraph 2.1. Annex 11 plus $1.5 \pm 2.5^\circ$.
- 3.1.7.6. The BioRID shall be installed such that its H-point is positioned 20 ± 10 mm forward of the R₅₀-point, as shown in Figure 14-2 below, while keeping the pelvis angle within the range specified in paragraph 3.1.7.5. above.

Figure 14-2

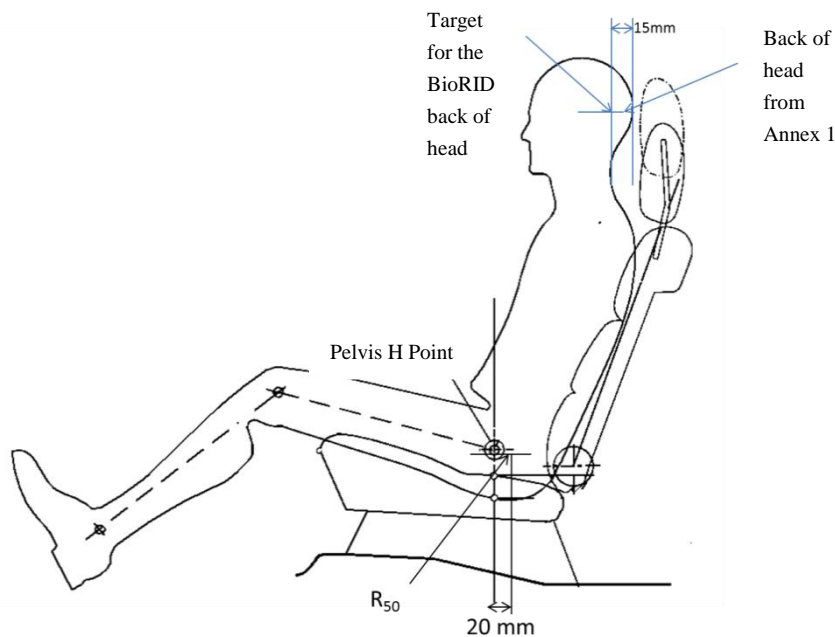

- 3.1.7.7. Back of head adjustment.
- 3.1.7.7.1. The back of head (the most rearward position of the head when the head is horizontally level $\pm 1^\circ$) of the BioRID shall be positioned at the reference position described in paragraph 3.1.6.2. of this annex with a tolerance of ± 5 mm.
- 3.1.7.7.2. If the test dummy back of head position is found to be different by more than ± 5 mm from that of the BioRID Reference Back of head, obtained by the procedure specified in paragraph 3.1.6.2. of this annex, then paragraphs 3.1.7.7.2.1. and 3.1.7.7.2.2. below shall apply.
- 3.1.7.7.2.1. Tip the head fore/aft no more than $+3,5 / -0,5^\circ$ from level in order to meet the backset requirement.
- 3.1.7.7.2.2. After carrying out the adjustments specified in paragraph 3.1.7.7.2.1. above and if it is still not possible to set the test dummy backset measurement to within 15 ± 2 mm of the Back of the Head reference position specified in paragraph 3.1.6.2. above then the dummy's pelvis angle and the H-point position shall be adjusted within their respective tolerance bands whilst prioritising the adjustment of the pelvis angle tolerance to achieve correct backset. It is not permitted to achieve the required position by pushing the dummy rearward.
- 3.1.7.8. The upper legs of the driver dummy shall rest against the seat cushion to the extent permitted by placement of the feet. Adjust the spacing of the legs so that the centreline of the knees and ankles is 200 mm (± 10 mm) apart and ensure that the knees are level.
- 3.1.7.8.1. Adjust the dummy's feet and/or the horizontal position of the adjustable toe board so that the heel of its shoe is resting on the heel surface. The tip of the shoe shall rest on the toe pan between 230 mm and 270 mm from the intersection of the heel surface and toe board, as measured along the surface of the toe board. The heel rest position is determined using the heel rest location defined from the vehicle measurements, or from specified point from the vehicle manufacturer.
- 3.1.7.8.2. The test dummy's upper arms shall be positioned so that they are as close to the sides of the dummy as possible, with the rear of the upper arms being in contact with the seatback and the elbows bent such that the small fingers of

both hands of the dummy are in contact with the vehicle seat cushion with the palms of the hands facing towards the dummy's thighs.

- 3.1.8. Seat belt adjustment.
- 3.1.8.1. With the test dummy seated in accordance with the requirements of paragraph 3.1.7. above, place the belt around the test dummy and fasten the latch. Remove all slack from the lap belt. Pull the upper torso webbing out of the retractor and allow it to retract. Repeat this operation four times. Apply a 9 to 18 N tension load to the lap belt. The lap belt routing shall be the resultant of the installation procedure and shall not be artificially altered.

4. Test Procedure.

4.1. Seat on Acceleration Sled (BioRID II UN).

The corridors for the pulse are illustrated in Figure 14-3. The sled acceleration shall be adjusted within the corridors described in Figure 14-3 and Table 14-1 for the complete time interval from 0 to 0.15s. The sled pulse shall fulfil the requirements as specified in Table 14-2.

Table 14-1
Acceleration versus time curve tolerances

		<i>Definition</i>	<i>Tolerance</i>	<i>Unit</i>
Velocity change	ΔV	17.6	± 0.9	km/h
Duration	ΔT	90.0	± 5.0	ms
Mean acceleration	Mean Acceleration	54.3	± 5.0	m/s ²
T=0 acceleration	AT0	0.0	± 3.0	m/s ²

Table 14-2
Sled pulse corridor reference point locations in Figure 14-3.

Entry Gate

<i>Time (ms)</i>	<i>Slope-Upper (m/s²)</i>	<i>Time (ms)</i>	<i>Slope-Lower (m/s²)</i>
4.2	10.8	8.4	10.8
5.3	14.2	9.5	14.2
6.3	18.0	10.5	18.0
7.4	22.3	11.6	22.3
8.4	27.0	12.6	27.0
9.5	32.2	13.7	32.2
10.5	37.8	14.7	37.8
11.6	43.7	15.8	43.7
12.6	49.8	16.8	49.8
13.7	56.0	17.9	56.0
14.7	62.2	18.9	62.2
15.8	68.4	20.0	68.4
16.8	74.3	21.0	74.3
17.9	80.0	22.1	80.0
18.9	85.2	23.1	85.2

Peak Gate

<i>Time (ms)</i>	<i>Max-Horizontal (m/s²)</i>	<i>Time (ms)</i>	<i>Max-Vertical (m/s²)</i>
17.9	113.3	28.4	82.4
38.9	113.3	28.4	92.7

Exit Gate

Time	1g Level-Upper (m/s ²)	Time	1g Level-Lower(m/s ²)
105.0	10.3	105.0	-10.3
147.0	10.3	147.0	-10.3

Figure 14-3

Acceleration versus time curve and Permissible Range of curve for the test set-up according to section 3.1. (The target acceleration with time expressed in milliseconds shall meet the value in the Table 14-2.)

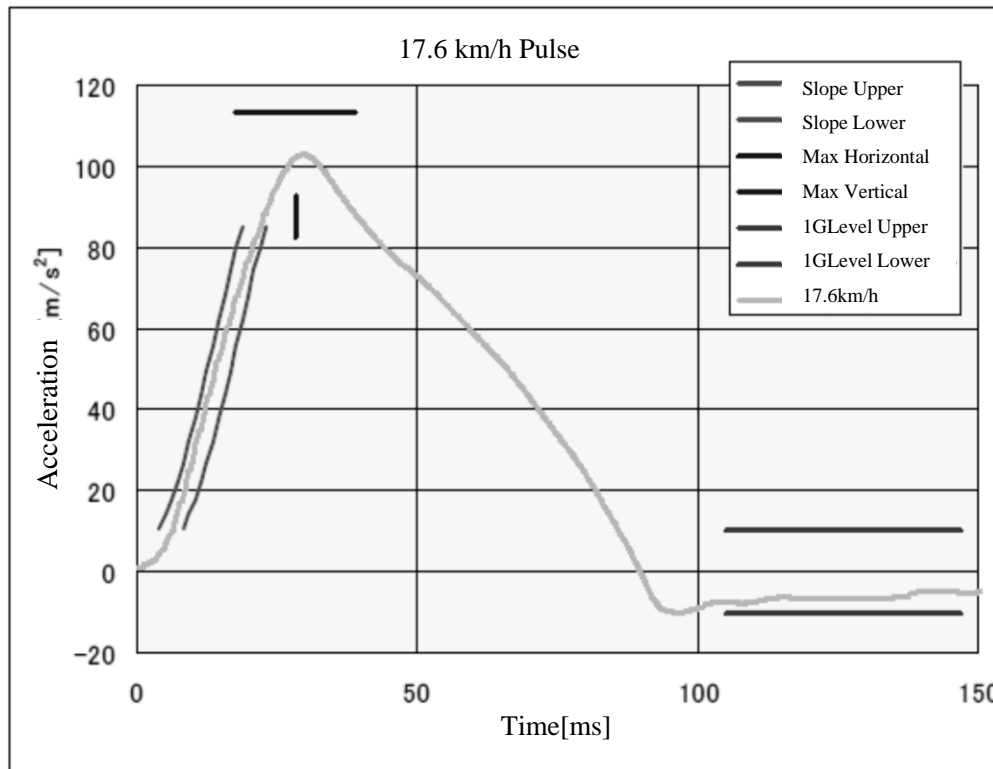

4.1.1. Data processing and definitions.

4.1.1.1. Filter with CFC 60.4.1.1.

To ensure that low level noise does not influence the results, the acceleration signal shall be filtered with a CFC60 filter. The CFC60 filter shall be used according to SAE J211, for sled acceleration signals.

4.1.1.2. T₀ definition

The T₀(T_{zero}) shall be defined as the time 5.8 ms before the CFC60 filtered sled acceleration reaches a 1.0g level.

4.1.1.3. T(end) definition

The time when the CFC60 filtered sled acceleration for the first time is < 0g shall be called T(end).

4.1.1.4. Time span definition

The time span for sled pulse corridor shall be defined as $dT = T(\text{end}) - T_0$.

4.1.1.5. Head and head restraint contact time (T-HRCstart, T-HRCend)

Head restraint contact time start, T-HRCstart, is defined as the time (calculated from T=0) of first contact between the back of the dummy's head and the head restraint, where the subsequent continuous contact duration exceeds 40 ms. T-HRCstart shall be expressed in ms and rounded to one decimal place. Two

decimal places of contact time (up to 1 ms) are permissible if it can be proven that these are due to poor electrical contacts; however, these must be investigated with reference to the film to ascertain whether the breaks in contact are not due to biomechanical phenomena such as dummy ramping, head restraint or seatback collapse, or "bounce" of the head during non-structural contact with the head restraint. For the subsequent criteria, the end of head restraint contact, i.e., T-HRCend, must also be found. This is defined as the time at which the head first loses contact with the head restraint, where the subsequent continuous loss of contact duration exceeds 40 ms.

4.2. Measurements to be Recorded

The electrical measurement data for the following parameters from the accelerometers and load cells mounted on the corresponding parts of the dummy and on the test sled shall be recorded from 20 ms before impact to 300 ms after impact or longer.

- (a) Longitudinal acceleration at the dummy's head;
- (b) Longitudinal force at the dummy's upper neck;
- (c) Vertical force at the dummy's upper neck;
- (d) Lateral axial rotation moment at the dummy's upper neck;
- (e) Longitudinal force at the dummy's lower neck;
- (f) Vertical force at the dummy's lower neck;
- (g) Lateral axial rotation moment at the dummy's lower neck;
- (h) Longitudinal acceleration on the right side of the dummy's T1 vertebra;
- (i) Vertical acceleration on the right side of the dummy's T1 vertebra;
- (j) Longitudinal acceleration on the left side of the dummy's T1 vertebra;
- (k) Vertical acceleration on the left side of the dummy's T1 vertebra;
- (l) Signal of contact between the back of the dummy's head and the head restraint.

4.3. Injury Criteria

The injury criteria for the dummy shall be calculated, using the following method, from the waveform determined in paragraph 4.3.

4.3.1. Neck Injury Criterion

NIC is determined based on the velocity of the head relative to the T1 vertebra and horizontal acceleration. Each acceleration shall be calculated in meters per second squared (m/s^2), and the head's longitudinal acceleration shall be filtered at CFC 60. The T1 vertebra acceleration is measured on either side, but in the NIC calculation, the average of the left and right accelerations, which have both been filtered at CFC 60, shall be used.

This average acceleration is determined as follows:

$$T1(t) = \frac{T1_{left}(t) + T1_{right}(t)}{2}$$

T1left(t) = Acceleration measured by accelerometer on the left side of the T1 vertebra

T1right(t) = Acceleration measured by accelerometer on the right side of the T1 vertebra

The "relative longitudinal acceleration" between the head and T1 vertebra (γ_x^{rel}) shall be generated by subtracting the head longitudinal acceleration (

γ_x^{Head}) from the left-right average of the T1 vertebra longitudinal acceleration (γ_x^{T1}).

This acceleration is calculated as follows:

$$\gamma_x^{rel} = \gamma_x^{T1} - \gamma_x^{Head}$$

The "relative longitudinal velocity" between the head and T1 vertebra (V_x^{rel}) shall be calculated, by integrating the relative acceleration with respect to time, as follows:

$$V_x^{rel}(t) = \int_0^t \gamma_x^{rel}(\tau) d\tau$$

The NIC channel is then calculated as a combination of relative acceleration multiplied by 0.2, and added to the square of the relative velocity. The calculation is performed using the following equation:

$$NIC(t) = 0.2 * \gamma_x^{rel}(t) + [V_x^{rel}(t)]^2$$

The maximum overall NIC value (NIC_{max}) shall be determined, considering only the portion of data from T=0 (start of test) until T-HRC(end) (end of contact between head and head restraint), as follows:

$$NIC_{max} = \underset{T-HRC(end)}{Max} [NIC(t)]$$

4.3.2. Upper neck shear force (Upper Neck Fx) and lower neck shear force (Lower Neck Fx)

These are shear forces measured by the dummy's upper neck and lower neck load cells assessed before the moment of rebound.

If the instrumentation is configured in accordance with SAE J211 relative movement of the head rearward is considered positive and relative movement of the head forward is considered negative.

Data shall be filtered at CFC 1000, and the maximum absolute value of the force shall be determined, considering the portion of data from T=0 until T-HRC(end) as follows:

$$Fx_{max} = \underset{T-HRC(end)}{Max} [|Fx(t)|]$$

4.3.3. Upper neck lateral axial rotation moment (Upper Neck My)

This is the lateral axial rotation moment measured by the dummy's upper neck load cell assessed before the moment of rebound.

If the instrumentation is configured in accordance with SAE J211, positive lateral axial rotation moment shall indicate flexion of the neck (head rotating forwards) and negative lateral axial rotation moment shall indicate extension (head rotating rearwards). Data shall be filtered at CFC 600. Due to the construction of the dummy, a correction shall then be made to convert the actual moment measured by the upper neck load cell into the moment about the occipital condyle (OC), as shown below:

$$My^{OC}(t) = My^{Upper}(t) - DFx^{Upper}(t)$$

$$D = 0.01778$$

The maximum absolute value of the moment about the OC shall be determined, considering the portion of data from T=0 until T-HRC(end).

$$My_{max}^{OC} = \underset{T-HRC(end)}{Max} [|My^{OC}(t)|]$$

4.3.4. Lower neck lateral axial rotation moment (Lower Neck My)

This is the lateral axial rotation moment measured by the dummy's lower neck load cell assessed before the moment of rebound.

If the instrumentation is configured in accordance with SAE J211, positive lateral axial rotation moment shall indicate flexion of the neck (head rotating forwards) and negative lateral axial rotation moment shall indicate extension (head rotating rearwards). Data shall be filtered at CFC 600, and the maximum absolute value of the moment shall be determined, considering the portion of data from T=0 until T-HRC(end), as follows:

$$My_{\max} = \underset{T-HRC_{(end)}}{Max} [|My(t)|]$$

Annex 15

Non-Use Position Test Procedure

1. Purpose
Procedures for folding or retracting head restraints in all designated seating positions equipped with head restraints, except the driver's designated seating position.
2. Procedures to test automatic return head restraints and demonstrate compliance with paragraph 5.8.4.1.
The procedure is completed with the ignition switched "on", and using a 5th percentile female Hybrid III test dummy in accordance with paragraph 2.1. of this annex, or a human surrogate in accordance with paragraph 2.2. of this annex. Compliance shall be determined at a temperature of 23 ± 5 °C.
 - 2.1. Use of 5th percentile Hybrid III Dummy.
 - 2.1.1. Position the test dummy in the seat such that the dummy's midsagittal plane is aligned within the 15 mm of the seating position centreline and is parallel to a vertical plane parallel to the vehicle longitudinal centreline.
 - 2.1.2. Hold the dummy's thighs down and push rearward on the upper torso to maximize the dummy's pelvic angle.
 - 2.1.3. Place the legs as close as possible to 90° to the thighs. Push rearward on the dummy's knees to force the pelvis into the seat so there is no gap between the pelvis and the seat back or until contact occurs between the back of the dummy's calves and the front of the seat cushion such that the angle between the dummy's thighs and legs begins to change.
 - 2.1.4. Note the position of the head restraint. Remove the dummy from the seat. If the head restraint returns to a retracted position upon removal of the dummy, manually place it in the noted position. Determine compliance with the height requirements of paragraph 5.6.2. by using the test procedures of Annex 10.
 - 2.2. Human surrogate.
A human being who weighs between 47 and 51 kg, and who is between 140 and 150 cm tall may be used. The human surrogate shall be dressed in a cotton T-shirt, full length cotton trousers, and sneakers. Specified weights and heights include clothing.
 - 2.2.1. Position the human in the centre of the seat with the pelvis touching the seat back and the back against the seat back;
 - 2.2.2. Verify the human's midsagittal plane is vertical and within ± 15 mm of the seating position centreline;
 - 2.2.3. Verify the transverse distance between the centres of the front of the knees is 160 to 170 mm. Centre the knee separation with respect to the seat centreline;
 - 2.2.4. If needed, extend the legs until the feet do not contact the floor pan. The thighs are resting on the seat cushion;
 - 2.2.5. If the human contacts the roof interior, move the seat rearward until a maximum clearance of 5 mm is achieved or the seat is in the closest detent position which does not cause human contact.
 - 2.2.6. Passenger foot positioning.
 - 2.2.6.1. Place feet flat on the toe board; or

- 2.2.6.2. If the feet cannot be placed flat on the toe board, the feet are perpendicular to the lower leg, and the heel is as far forward as possible and resting on the floor pan; or
- 2.2.6.3. If the heels do not touch the floor pan, the legs are vertical and the feet parallel to the floor pan.
- 2.2.7. Passenger arm/hand positioning.
 - 2.2.7.1. Place the human's upper arms adjacent to the torso with the arm centrelines as close to a vertical longitudinal plane as possible.
 - 2.2.7.2. Place the palms of the human in contact with the outer part of the thighs.
 - 2.2.7.3. Place the little fingers in contact with the seat cushion.
- 2.3. Start the vehicle engine or place the ignition in the "on" position, whichever will turn on the suppression system, and close all vehicle doors. Note the position of the head restraint. Remove the human from the seat. If the head restraint returns to a retracted position upon removal of the human, manually place it in the noted position. Determine compliance with the height requirements of paragraph 5.6.2. by using the test procedures of Annex 10.
- 2.4. Return the ignition switch to the "off" position.
- 3. 60° Rotation Evaluation
 - Procedures for the rear and front centre designated seating positions to demonstrate compliance with paragraph 5.8.4.2.
 - 3.1. Place the head restraint in any position meeting the requirements of paragraph 5.6.2.2. or paragraph 5.6.2.4. or paragraph 5.6.2.6. of the Regulation;
 - 3.1.1. Mark a line on the head restraint with one end at the point of rotation. Measure the angle or range of angles of the head restraint reference line as projected onto a vertical longitudinal vehicle plane;
 - 3.1.2. Fold or retract the head restraint to a position in which its minimum height is less than that specified in paragraph 5.6.2.2. or paragraph 5.6.2.4. or paragraph 5.6.2.6.;
 - 3.1.3. Determine the minimum change in the head restraint reference line angle as projected onto a vertical longitudinal vehicle plane from the angle or range of angles measured in paragraph 3.1.1. of this annex.
- 4. Discomfort Metric
 - Procedures for the rear and front centre designated seating positions to demonstrate compliance with paragraph 5.8.4.3. of this Regulation.
 - 4.1. The HLE and S dimensions are defined in Figure 15-1 is a vertical fore-aft plane passing through the R-point (i.e. at the midpoint of the designated seating position) intersecting the seat cushion, seat back and the head restraint.
 - 4.2. Adjust the head restraint to the non-use position.
 - 4.2.1. HLE is the distance from the R-point to the lower edge of the head restraint measured along the torso line.
 - 4.2.2. S is the maximum thickness of the lower edge of the head restraint (as determined within 25 mm of the head restraint lower edge) measured perpendicular to the torso line between TH and TS from line P.
 - 4.2.3. P is a line parallel to the torso line which intersects the head restraint at TS.
 - 4.2.4. TH is the line perpendicular to the torso line and tangent to the lower edge of the head restraint.
 - 4.2.5. TS is the line parallel to and 25 mm from TH.

5. 10° Change in Actual Torso Angle.
Procedures for the rear and front centre designated seating positions to demonstrate compliance with paragraph 5.8.4.4.
- 5.1. Place the head restraint into any position meeting the requirements of paragraph 5.6.1. of this Regulation;
- 5.2. Measure the actual torso angle with the three-dimensional H-point machine defined in Annex 3;
- 5.3. Fold or retract the head restraint to any position in which its minimum height is less than that specified in paragraph 5.6.2. of this Regulation; and
- 5.4. Again measure the actual torso angle.

Figure 15—1.

