

Proposal for a new Annex C to UN GTR No. 24 on Laboratory Measurement of Brake Emissions for Light-Duty Vehicles

Version 26.06.2023

Contents

- I. STATEMENT OF TECHNICAL RATIONALE AND JUSTIFICATION
- II. TEXT OF THE ANNEX C
 - 1. Purpose
 - 2. Scope and Application
 - 3. Definitions
 - 3.1. Vehicle and Brake Dynamometer Settings
 - 3.2. Test System
 - 4. Abbreviations and Symbols
 - 5. Reference Methods and Calculations
 - 5.1. Calculation of Friction Braking Share Coefficient c
 - 5.2. Methods to Determine the Friction Work
 - 5.2.1. Torque Based Method
 - 5.2.2. Pressure Based Method
 - 5.2.3. Method for Electromechanical Brakes
 - 5.2.4. Alternative Methods
 - 5.3. Determination of C_p and C_e
 - 5.3.1. Calibration of Brake Dynamometer
 - 5.3.2. Operation
 - 5.3.3. C_p Calculation
 - 5.3.4. C_e Calculation
 - 6. Testing Setup and Specifications
 - 6.0 Vehicle Selection
 - 6.0.1 Definition of friction braking share coefficient type (families)
 - 6.1. Preparation
 - 6.1.1 Torque Sensors and their Calibration
 - 6.1.2. Pressure Transducers and Sensors and their Calibration
 - 6.1.3. Sensors for Force Measurements on Electromechanical Brake systems and their Calibration
 - 6.2. Data Recording
 - 6.2.1. Chassis Dynamometer Data
 - 6.3 Chassis Dynamometer Settings
 - 6.3.1. Consideration of Road Loads
 - 6.4. Test Sequence WLTP-Brake cycle
 - 7. Equivalency of Methods
 - 7.1. Selection of Vehicle and Electrification Concept for Proof of Equivalency
 - 7.2. Testing of the Alternative Method
 - 7.3. Equivalence Criterion
 - 8. Equivalency of Test Cycle
 - 8.1. WLTP- Brake-Trip10
 - 8.2. WLTC (Exhaust)
 - 8.3. Offset of the Friction Braking Share Coefficient (“Declaration”)
 - 9. Test Output

I. Statement of technical rationale and justification

II. Text of the Annex C

1. Purpose

This document provides the procedure to determine vehicle-specific friction braking share coefficients for use with the Global Technical Regulation on the measurement of brake wear particulate matter and particle number emissions from brakes used on Light-Duty vehicles. The method described in this annex may be used as an alternative to the friction braking share coefficients of the GTR, given in paragraph 5.2 table 5.1. In this case the information according to Annex C will be provided by the vehicle manufacturer in Table [13.7], Par. [13.4] of the GTR.

2. Scope and Application

The GTR on Brake Particle Emissions is applied to all types of light duty vehicles. The method described in this Annex C may be applied to all vehicle types with non-friction braking capabilities. It is meant as enhancement for Table 5.1., and describes the methodology for establishing the friction braking share coefficients for vehicle specific categories [NOVC-HEV Cat.1, NOVC-HEV Cat.2, OVC-HEV and PEV].

This Annex C describes the method setup and procedures for running WLTP-Brake cycle tests on a chassis dynamometer and how to determine the vehicle-specific friction braking coefficient. It states a procedure and acceptance criteria for the use of alternative methods. Furthermore, it provides a procedure how to transform the vehicle specific friction braking share coefficient measured of the vehicle running on the WLTP-Brake-Trip10, or the WLTC (Exhaust) to vehicle-specific friction braking share coefficient of the identical vehicle running on WLTP-Brake cycle.

3. Definitions

3.1. Vehicle and Brake Dynamometer Settings

3.1.1. "Road loads" means the opposition to the movement of a vehicle. In this UN GTR, a reduction of the brake nominal inertia by a fixed percentage of 13 per cent is considered to account for road loads in full-friction braking emissions testing.

3.1.2. "Friction braking share coefficient" is the ratio of total energy absorbed by the full friction brake system during a drive cycle, to the total kinetic energy variation of the vehicle during braking events (less road load) over the same drive cycle.

3.2. Test system

3.2.1. "Torque measurement sensor" is i) an electromechanical device that converts the torsional strain of the brake assembly into the equivalent output. The equivalent torque is derived from the angular deceleration rate and the effective brake inertia; ii) a device can be used to measure the force at the brake calliper and calculate the according torque by use of the correct geometric parameters.

3.2.2. "Pressure sensor" for this annex means an electromechanical device that is connected to the brake fluid path close to the brake system and provides a signal that is equivalent to the brake pressure at the corresponding brake corner.

3.2.3. "Torque to Pressure ratio" (C_p) is a constant value that converts the brake pressure (Pa) into braking torque (Nm) of a friction brake.

3.2.4 "Torque to Electric Power ratio" (C_e) is a transfer function that converts measured electric power into braking torque (Nm) of an electromechanical friction brake.

3.2.5. "Tyre dynamic rolling radius" means the tyre radius that equates to the revolutions per kilometre (or revolutions per mile) published by the tyre manufacturer for the specific tyre size (mm).

3.2.6. "Vehicle speed" is the vehicle speed as given by the drive trace of the chassis dynamometer

3.2.7 "Set vehicle speed" corresponds to the setpoint of the vehicle speed at a certain time of the test

3.2.8. "Chassis dynamometer" means a technical system that imposes and controls a drive schedule on a complete vehicle, while recording relevant data, complying to the requirements of GTR 15.

4. Abbreviations and Symbols

<i>Symbol/Abbreviation</i>	<i>Definition</i>	<i>Unit</i>	<i>Paragraph</i>
C_p	Torque to pressure ratio converting measured brake pressure (Pa) into braking torque (Nm)	Nm/Pa	5.2, 5.3, 5.3.3
C_e	Electromechanical brake: Torque to power ratio converting measured brake power (W) into braking torque (Nm)	Nm/W	5.2, 5.3, 5.3.4, 6.1.3
c	Friction braking share coefficient calculated from WLTP-Brake cycle	-	5.1, 8.1, 8.2
c_{trip10}	Friction braking share coefficient calculated from WLTP-Brake-Trip10 cycle	-	8.1
c_{exh}	Friction braking share coefficient calculated from WLTC (Exhaust)	-	8.2
c_{alt}	Friction braking share coefficient calculated from WLTP-Brake cycle through an alternative method	-	7.3
EMB	Electromechanical Brake	-	6.1.2
GTR	Global Technical Regulation	-	5, 5.2, 5.3, 6.2, 6.3, 6.4
I	Current in electromechanical brake	A	5.1, 5.2, 5.3, 6.1.3
$k_{br-trip10}$	Correlation factor between WLTP-Brake cycle and WLTP-Brake-Trip10 cycle	-	8.1
k_{br-ex}	Correlation factor between WLTP-Brake cycle and WLTC (Exhaust)	-	8.2
MRO	Mass in Running Order	kg	6.2.1
P_{br}	Measured electric power of electromechanical full-friction brakes	W	5.2
p_{brake}	Measured braking pressure	bar	5.2
r_R	Tyre dynamic rolling radius	m	5.2
t	Duration of a braking event	s	5.2
T_{brake}	Measured brake torque	Nm	5.2.1
U	Voltage in electromechanical brake	V	5.1, 5.2.4, 6.1.3.
W_{brake}	Friction work, which is the sum of the energy dissipated in the full friction brake system during all braking events in the relevant schedule	J	5.1, 5.2, 7.3
$W_{total,bc}$	Sum of the kinetic energy variation of the vehicle during all braking events. For the WLTP-Brake cycle $W_{total,bc}$ is calculated by multiplying the vehicle test mass M_{veh} with 15983 J/kg	J	5.1
$W_{ref,bc}$	Sum of kinetic energy variation during all braking events ($W_{total,bc}$) of the WLTP-Brake cycle, reduced by an arbitrary road load contribution share of 13%. $W_{ref} = W_{total} \times 0.87$	J	5.1

<i>Symbol/Abbreviation</i>	<i>Definition</i>	<i>Unit</i>	<i>Paragraph</i>
$W_{\text{total, Trip10}}$	Sum of the kinetic energy variation of the vehicle during all braking events of WLTP-Brake-Trip10. It is calculated by multiplying the vehicle test mass M_{veh} by 5555 J/kg	J	5.1
W_{ref}	Sum of kinetic energy variation during all braking events of the test cycle	J	5.1
$W_{\text{ref, Trip10}}$	Sum of kinetic energy variation during all braking events of WLTP-Brake-Trip10 ($W_{\text{total, Trip10}}$) reduced by an arbitrary road load contribution share of 13%	J	5.1
$W_{\text{ref, Exhaust}}$	Sum of kinetic energy variation during all braking events of the WLTC (Exhaust). It is calculated by multiplying the vehicle test mass M_{veh} by 3578 J/kg.	J	5.1
WLTP	Worldwide harmonized Light vehicle Test Procedure	-	5
v	Measured vehicle speed	m/s	5.2, 5.3

5. Reference Method and Calculation

The vehicle individual friction braking share coefficient shall be determined applying the WLTP-Brake cycle on a fully GTR15 compliant chassis dynamometer. All brakes shall be equipped with external sensors to determine the brake torque at each of the wheels. Alternatives and acceptance criteria are described in Chapter 8 of this annex.

5.1. Calculation of Friction Braking Share Coefficient c

In the main GTR the brake particle emission factors are determined on a brake dynamometer, which is set to the respective road load considering reducing the inertia by 13% of the vehicle mass. In order to be consistent, the friction braking share coefficient is calculated as ratio of “stopping energy dissipated by the friction brakes” divided by “total stopping energy reduced by road loads (defined as 13% in the GTR)”.

Friction braking share coefficient

$$c = \frac{W_{\text{brake}}}{W_{\text{ref}}} \quad (\text{Eq. 1})$$

Where:

- C is the friction braking share coefficient.
- W_{brake} is the friction work, sum of the energy dissipated in the full-friction brake system during all braking events in J;
- $W_{\text{ref, bc}}$ is sum of kinetic energy variation during all braking events of the WLTP-Brake cycle ($W_{\text{total, bc}}$) reduced by arbitrary 13% to consider road load losses, $W_{\text{ref, bc}} = W_{\text{total, bc}} * 0.87$ in J.
- $W_{\text{ref, trip10}}$ is sum of kinetic energy variation during all braking events of WLTP-Brake-Trip10 ($W_{\text{total, Trip10}}$) reduced by arbitrary 13% to consider road load losses, $W_{\text{ref, trip10}} = W_{\text{total, trip10}} * 0.87$ in J.
- $W_{\text{ref, exh}}$ is sum of kinetic energy variation during all braking events of the WLTC (Exhaust) ($W_{\text{total, exh}}$) in J. $W_{\text{ref, exh}}$ is calculated by multiplying the vehicle test mass M_{veh} by 3578 J/kg.
- $W_{\text{total, bc}}$ is the sum of the kinetic energy variation of the vehicle during all braking events, of WLTP-Brake cycle. The $W_{\text{total, bc}}$ is calculated by multiplying the vehicle test mass M_{veh} by 15983 J/kg.

$W_{total,trip10}$ is the sum of the kinetic energy variation of the vehicle during all braking events of WLTP-Brake-Trip10. The $W_{total,trip10}$ is calculated by multiplying the vehicle test mass M_{veh} by 5555 J/kg.

5.2. Methods to Determine the Friction Work

The methods described in 5.2.1, 5.2.2, or 5.2.3 shall be applied by the vehicle manufacturer to determine the friction braking share coefficient for type approval testing.

5.2.1. Torque Based Method

The torque-based method requires the direct measurement of the actual braking-torque (T_{brake}) at the respective full-friction front and rear brake-systems. The brakes represent the front and rear axle during the brake application of the driving cycle.

The energy dissipated by full-friction braking is calculated according to equation (2)

$$W_{brake} = \sum_{i=1}^N \frac{1}{r_R} \int T_{brake_i} \cdot v dt \quad (\text{Eq. 2})$$

Where:

W_{brake} is the friction work, sum of the energy dissipated at the full-friction brake systems during all “N” braking events in J;
 T_{brake} is the measured brake torque in Nm;
 v is the vehicle speed in m/s;
 r_R is the tire dynamic rolling radius in m;
 t is the duration of a braking event in s.

5.2.2. Pressure Based Method

The pressure-based method requires the determination of the pressure in the hydraulic full-friction brake systems as close to the wheel as possible in terms of safety, handling, and measurement quality (see Figure C.4 for details). The energy dissipated at hydraulic full-friction brakes is calculated from the measured brake pressure (p_{brake}) multiplied by the torque to pressure ratio (C_p) at the respective front and rear brakes (representing front and rear axle) during the brake applications of the driving cycle according to equation (3)

[Note: In the following the formula are written not yet specified for front and rear brakes. Could be separated into front axle and rear axle].

$$W_{brake} = C_p \sum_{i=1}^N \int_0^t p_{brake} * 10^5 * \frac{v}{r_R} dt \quad (\text{Eq. 3})$$

Where:

W_{brake} is the friction work, sum of the energy dissipated at the full-friction brake during all braking events in J;
 C_p is the torque to pressure ratio in Nm/Pa;
 p_{brake} is the brake pressure measured in bar;
 v is the vehicle speed in m/s;
 r_R is the tire dynamic rolling radius in m;
 t is the duration of a braking event in s.

5.2.3. Method for Electromechanical Brakes

The energy dissipated at electromechanical full-friction brake system is calculated from the measured electric power (P_{br}) multiplied by the torque to electric power ratio (C_e) at the respective front and rear brakes (representing front and rear axle) during the brake applications of the driving cycle.

The energy dissipated by full-friction braking is calculated according to equation 4:

$$W_{brake} = C_e \sum_{i=1}^N \int_0^t P_{br} * \frac{v}{r_R} dt \quad (\text{Eq. 4})$$

Where:

W_{brake} is the friction work, sum of the energy dissipated at the full-friction brake during all “N” braking events in J;

C_e is torque to power ratio converting measured brake power into braking torque in Nm/W;

P_{br} is the measured electric power of electromechanical full-friction brakes in W;

v is the vehicle speed in m/s;

r_R is the tire dynamic rolling radius in m;

t is the duration of a braking event in s.

5.2.4. Alternative Methods

Additionally to the reference methods described in paragraphs 5.2.1, 5.2.2., and 5.2.3. the following alternative methods may be applied:

The brake torque and signals provided by electronic buses (e.g. CAN-Bus signals) of the vehicle that allow the calculation of the brake torque based on the methods 5.2.1, 5.2.2 or 5.2.3 shall be used. The equivalency criterion is described in Chapter 7. Similarity of the signals with the chosen reference method shall be confirmed by the Technical Authorities.

5.3. Determination of C_p and C_e Values

The C_p value for the pressure based method (or C_e value for the method for electromechanical brakes) for a specific brake system is determined by running the WLTP-Brake cycle on a brake dynamometer compliant to this GTR.

5.3.1 Calibration of Brake Dynamometer

The brake dynamometer and all testing equipment should be setup and operated according to this GTR.

5.3.2. Operation

1. Install the brake according to the measurement procedure of this GTR.
2. Run WLTP-Brake cycle according to this GTR
3. Depending on brake type, record:
 - a. brake torque and brake pressure for hydraulic or electro-hydraulic brake, or
 - b. brake torque and electric power (current, voltage and additional required signals) for an electromechanical brake.

Note: Usage of "Slow sampling rate" channels for the C_p or C_e evaluation as per 3.1.29. is recommended.

5.3.3. C_p Calculation

C_p value describes the relationship between brake pressure and brake torque:

$$C_p = \frac{\text{Brake Torque}}{\text{Brake Pressure}} \quad (\text{Eq. 5})$$

For a given friction material, C_p may depend on vehicle speed, applied brake pressure, brake rotor and pad temperature. It may change from brake snub to brake snub during the execution of the test.

To reduce the influence of C_p variability on brake energy calculation in the test cycle, “energy weighted C_p value” according to the formula below is used:

If the applied brake pressure is smaller or equal to 0.5 bar, the data point will not be considered for C_p calculation for decelerations events ($a(t) < 0$). If the applied brake pressure is larger than 0.5 bar, C_p is calculated as follows for deceleration events ($a(t) < 0$):

$$C_{p,avg} = \frac{\int_{t=0}^{End} v(t) \times a(t) \times \frac{Tq(t)}{p(t)} dt}{\int_{t=0}^{End} v(t) \times a(t) dt} \quad (\text{Eq. 6})$$

In case of running WLTP-Brake-Trip10 on the chassis dynamometer to determine the friction braking share coefficients (see paragraph 8.1.) the C_p (or C_e) shall be evaluated using the data of the WLTP-Brake-Trip10 on the brake dynamometer.

5.3.4. C_e Calculation

Torque to electric power ratio (C_e) is a transfer function that converts measured electric power into braking torque (Nm) of an electromechanical friction brake.

C_e value describes the relationship between brake power for actuation and brake torque:

$$C_e = \frac{\text{Brake Torque}}{U \times (I_{\text{apply}} - I_{\text{idle}})} \quad (\text{Eq. 7})$$

Where U is the voltage, I_{apply} is the measured current draw when the brake is applied, and I_{idle} is the measured current draw when the brake is fully released.

C_e is analogous to C_p , for a given friction material and may depend on vehicle speed, applied brake clamping force, brake rotor and pad temperature. It may change from brake snub to brake snub during the execution of the test.

To reduce the influence of C_e variability on brake energy calculation in the test cycle, “energy weighted C_e value” according to the Eq. 8 below is used:

If the applied brake power (above idle) is smaller or equal to [0.2] Watt, the data point will not be considered for C_e calculation for decelerations events ($a(t) < 0$).

C_e is calculated as follows for deceleration events ($a(t) < 0$):

$$C_{e,avg} = \frac{\int_{t=0}^{End} v(t) \times a(t) \times C_e(t) dt}{\int_{t=0}^{End} v(t) \times a(t) dt} \quad (\text{Eq. 8})$$

In case of running WLTP-Brake-Trip10 on the Chassis Dynamometer for establishing of the friction braking share coefficients (see paragraph 8.1.) the C_e evaluation as described above should be carried out for data of WLTP-Brake-Trip10.

6. Testing Setup and Specifications

6.0. Vehicle Selection

The vehicle shall be selected as described in the following paragraph 6.0.1. The c-factor determined for this vehicle shall apply to all vehicles belonging to the same category and shall be used in Eq. 12.9, Eq. 12.10, Eq. 12.13, and Eq. 12.14 in the GTR.

6.0.1 Definition of friction braking share coefficient type (families)

[...]

6.1. Preparation

6.1.1 Brake Torque Sensors and their Calibration

Piezoelectric sensors

The brake torque sensor is a sensor, for example based on the piezoelectric effect, which is capable to measure the true amount of brake torque directly at the position where the torque occurs – between calliper and knuckle. Brake torque sensor are typically tailored to fit into the individual brake systems. Typically, depending on the mounting bolt diameter, the thickness is between 3.5 and 5 mm.

For this method, external torque sensor(s) shall be mounted to the calliper for each brake corner of the vehicle. Depending on the technical layout of the brake and the sensor, one sensor per mounting hole, or the integration in a single tool is required. If necessary, (e.g., due to space limitations), the calliper or pad may be re-machined to allow the application of the sensor(s), however great care should be taken that the calliper is still able to fulfil the intended requirements of the WLTP-Brake cycle without any safety risk or negative impact on the braking behaviour (e.g. due to deformation) within the operation range of the sensor as specified by the sensor manufacturer.

The measured torque over time shall be converted to brake energy according to Eq. 2 described in paragraph 5.2. Due to the functional principle of the sensor it is required to check the zero stability before and after the test, and take any drift into account.

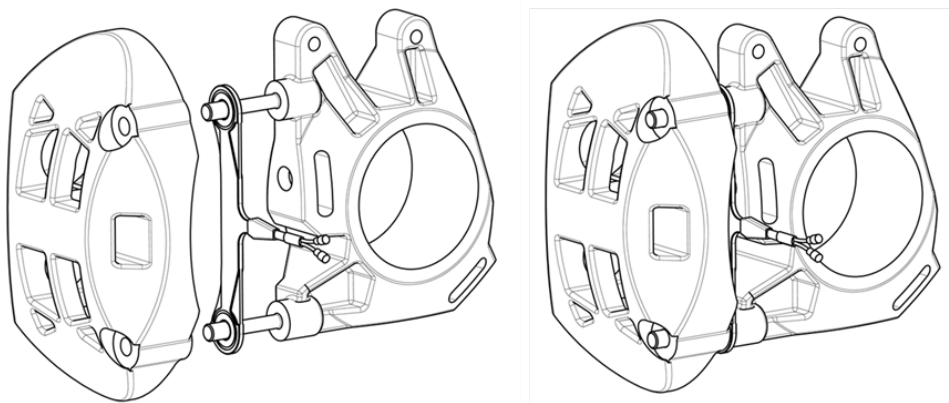

Figure C.1. Schematic example of brake torque sensor mounting.

An overall resulting range of 0 – [800 Nm] is recommended, while the maximum range of the sensor shall be chosen according to the vehicle mass, geometry of the brakes and the expected resulting torque conditions during the tests.

Refer to the recommendations of the brake-, vehicle- and sensor system manufacturer to ensure proper function of the sensor and data collection devices.

Sensor calibrations shall meet the following specifications:

- The accuracy of the sensor system should be [2 %] of full-range or [+/-5 Nm], whichever is larger
- The torque sensors shall be adjusted to zero before the test with no brake torque applied to the system.
- Adjustments of more than [+/-YYY Nm] of full-scale are not permitted.
- After the test, the torque sensors shall be checked for zero drift. A max. zero-drift of [+/-XXX Nm] is acceptable.

For the calibration, a reference calibration sensor is required. After the installation of the Brake Torque Sensor, the reference calibration sensor is attached to the wheel and torque is applied (see Figure C.2)

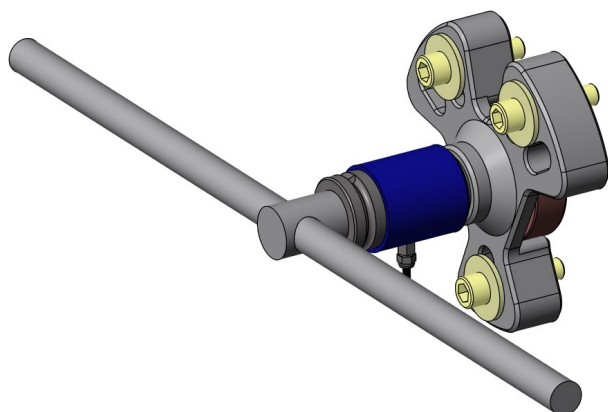

Figure C.2: T-handle and Reference Calibration Sensor attached via wheel hub adapter to the wheel hub.

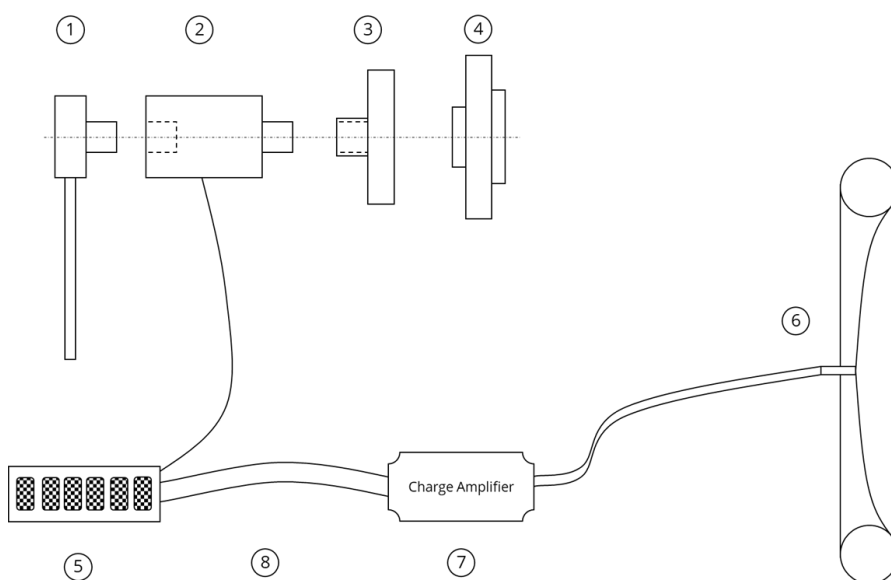

Figure C.3: Schematic example of calibration.

No.	Article
1	Standard wrench square drive (which fits in the reference sensor)
2	Reference calibration sensor
3	Wheel hub adapter (to apply torque directly on the axle)
4	Wheel hub
5	Data acquisition system (which is compatible with strain gauge input)
6	Brake Torque Sensor(s) incl. cable
7	Charge amplifier
8	System Cable with Connector to data acquisition system

The linearity of the sensor shall be checked according to the recommendation of the measurement system manufacturer. It shall not show residuals larger than [5% or +/-X Nm, whichever is larger] at any point of the operational range above zero.

The measurement system may be compensated for temperature influence if the sensor temperature is measured. The temperature dependency of the [compensated] system shall be less or equal to [0,01 Nm / K]

The measurement system shall be calibrated according to ISO 17025 within the last 12 month of usage.

Strain gauges

Strain gauges shall be mounted at all brakes of the vehicle, in the caliper carrier area of the highest stress in the torsional direction. Due to a wide range of brake torque possibly acting on the brakes for different vehicles, the test facility may consider modifying/machining the caliper structure to increase deflection and provide better accuracy. This must be done in the way not compromising vehicle safety. The strain gauges must be build using a full bridge configuration, to ensure proper compensation of eventual torque value drift caused by brake temperature. Depending on tested vehicle and brake (vehicle mass, axle, regen capability, etc.), strain gauges system must be selected and installed according to expected torque range.

The calibration of the strain gauges shall be carried out on a torque verification bench, preferably brake dynamometer applying a sequence of torque steps covering the range during the WLTP emission test.

Ensure strain gauge system accuracy of [x%] of the Full Specification Range or [Y%] of measured value whatever is greater.

[Level of torque quantification shall not be greater than X Nm, e.g. 12 Nm as a result of calculation of measurement uncertainty equal to $20 \text{ Nm} / \sqrt{3}$].

[further information to be added and to align with requirements above]

6.1.2 Pressure Transducers and Sensors and their Calibration

For this method, an external pressure sensor shall be mounted to the brake fluid path for each brake corner of the vehicle. Preferably, it shall be mounted to the venting screw of the respective brake corner. If this is not possible due to space limitations or other issues, alternative mounting locations are allowed, however they should be located as close as possible to the according brake corner. The measured pressure over time shall be converted to brake energies and to friction braking share coefficients according to the Eq. 1 and Eq. 2 described in paragraph 5.1. and 5.2.

A range of 0 – [4000 kPa] is recommended, while the maximum range of the sensor shall be chosen according to the expected maximum pressure conditions during the tests.

Sensor calibrations shall meet the following specifications:

- uncertainty of measurement for pressure measurement- [0.5%] of reading or [0.1%] of full scale whichever is larger (entire uncertainty budget)

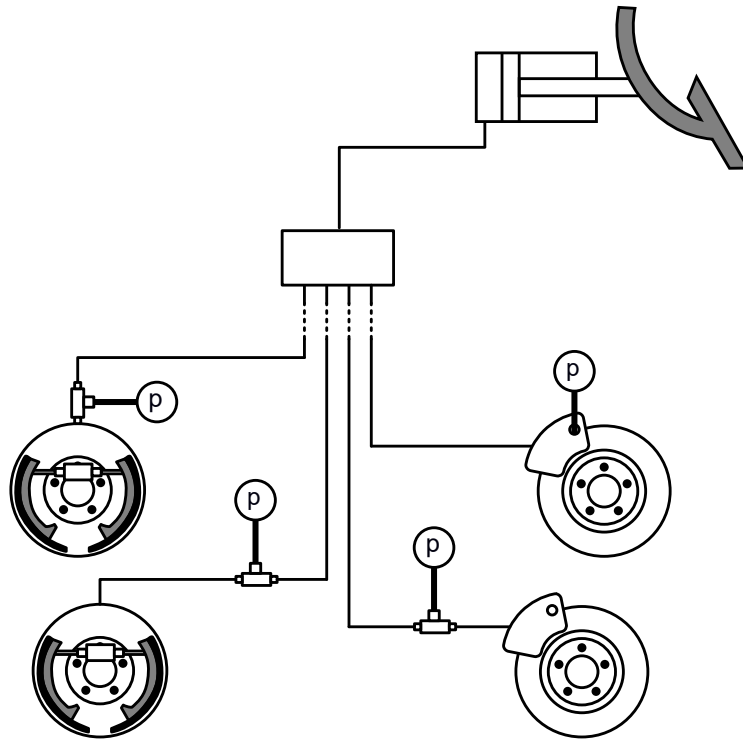

Figure C.4. Examples of mounting of brake pressure sensors (P) at brake pipes of the tested vehicles.

6.1.3. Sensors for Force Measurements on Electromechanical Brakes and their Calibration

For an electromechanical brake following approaches for brake torque estimation and calibration are valid:

Method 1: Measurement of electric current and voltage applied to the brake, and their conversion to brake torque using C_e ratio as described in paragraph 5.3.4.

Brake torque calibration – Occurs directly on the brake dynamometer within a WLTP-Brake-Trip10 cycle without recuperation – analogous to a test with a hydraulic brake.

Method 2: Measurement of electric current and voltage applied to the brake, and their conversion to brake clamping force using characteristics $F_{\text{clamp}} = f(I, U, \text{Temp, and others})$

Brake clamping force calibration – Occurs on a test bench, outside of brake dynamometer.

Method 3: Direct measurement of clamping force with a force sensor.

Brake clamping force calibration – Requires calibration of force sensors. Use Standard [XXX].

For cases 2 and 3, clamping force values over time shall be converted to brake torque using “clamping force to torque ratio”

Then for all cases, brake torque over time shall be converted to brake energies and to friction braking share coefficients according to the Eq. 1 and Eq. 2 described in paragraphs 5.1. and 5.2.

The sensors shall meet following specifications:

Clamping force sensor:

Range: A range equal to a double maximum expected force level during the test is recommended.

Uncertainty of measurement: [0.5%] of reading or [0.1%] of full scale whichever is larger (entire uncertainty budget)

Current measurement on 12 V systems:

Range: 0-35 A is recommended.

Uncertainty of measurement: [x.x%] of reading or [x.x%] of full scale whichever is larger (entire uncertainty budget)

Voltage measurement on 12 V systems:

Range: 0-16 V is recommended.

Uncertainty of measurement: [x.x%] of reading or [x.x%] of full scale whichever is larger (entire uncertainty budget)

[for systems with other voltage – to be specified]

Alternative methods of torque measurements for electromechanical brakes shall be allowed, if the equivalency principle as described in Chapter 7 is fulfilled – [more details to be added ...]

6.2. Data Recording

6.2.1. Chassis Dynamometer Data

During testing, dedicated data recording systems have to be used to log the raw data from the chassis dynamometer as well as from the vehicle and its instrumented components.

The data recording recommendations are referred to GTR 15 (Annex B5, Chapter 2 Chassis Dynamometer).

Additionally to the data requested in GTR15, foundation brake related parameters have to be recorded. This includes at least the parameters chosen by the main method and the reference method. The measurement has to be done with a frequency of not less than 10 Hz.

Regarding the vehicle masses, different specifications for the test mass have to be fulfilled:

- According to 3.2.25 of GTR15 for WLTC (Exhaust)
- According to 3.1.9 of this GTR for WLTP-Brake cycle
- According to 3.1.9 of this GTR for WLTP-Brake-Trip10

Moreover, the following input parameters must be documented:

- Tire dynamic rolling radius r_R
- Torque to Pressure ratio C_p or C_e values (if applicable)

The data recording has to start before or at the same time as the test. The data recording of dynamometer and vehicle has to ensure synchronized data, meaning that the signals have to refer to the same time trace. It is recommended to record the signals time-aligned on a single file. Alternatively, the vehicle speed signal shall be recorded together with the brake information and be used for time alignment, if the data is recorded on different systems.

Recorded data has to be provided in a common and open access data format.

6.3. Chassis Dynamometer Settings

The test setup and method fulfills the requirements of UN GTR No. 15 in the currently valid version as available at (<https://wiki.unece.org/display/trans/Latest+GTR+15>). If the test refers to WLTC (Exhaust), for brake energy determination the 4-phase WLTC Class 3 cycle shall be used. No deviations, except the definitions in this document, are valid.

The tests shall be performed at $[23^{\circ}\text{C} \pm 2^{\circ}\text{C}]$ with the vehicle, brake systems and measurement systems soaked for at least [48 h].

6.3.1. Consideration of Road Loads

For both test cycles, WLTC (Exhaust) and WLTP-Brake cycle, the road load simulation is considered to be fully compliant to GTR No. 15. Soaking, pre-conditioning and Road load are set according to GTR No 15. This means, that the road load coefficients (f_0, f_1, f_2) of the road load equation are taken into account for the test execution.

6.4. Test Sequence

The test vehicle shall be run-in in accordance with the requirements in paragraphs 2 to 2.3. of Annex 8 to UN GTR No. 15

Generally, the test is carried out by applying the sequence of preconditioning, soaking and (for OVC-HEV and PEV) recharging, followed by the performance test to derive the friction braking share coefficients (see Figure C.5.). The requirements for those shall be as set out in Annex 8 of UN GTR No. 15, and particularly the following sections corresponding to the vehicle type being tested:

- NOVC-HEV (Cat.1 and Cat.2) – paragraphs 3.3.1.1.to 3.3.3.1.
- OVC-HEV – paragraphs 2.2. to 2.2.3.2. of Appendix 4 and paragraphs 3.2.4.2.1. and 3.2.4.2.2.
- PEV – paragraphs 3.4.2. to 3.4.4.1.

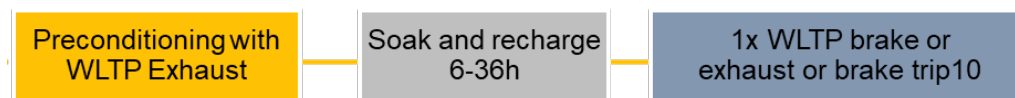

Figure C.5. Principle structure of chassis dyno testing according to this section

The vehicle shall be set and tested according to predominant mode as described in the Appendix 6 of Annex 8 to GTR 15, in paragraphs 2, 3 or 4 respectively for OVC-HEVs, NOVC-HEVs and PEVs.

Notwithstanding the above requirements, the applicable test cycle during the performance test shall be the WLTP-Brake cycle as described in Annex A. For OVC-HEV and PEV the cycle shall be driven only once.

In line with the provisions in Chapter 8 of this Annex the applicable test cycle above may be replaced by either:

- the WLTP-Brake-Trip10 cycle, or;
- the WLTC (Exhaust), being the 4-phase test cycle Class 3b as prescribed in paragraphs 3.3.2. to 3.3.2.5. of Annex 1 to UN GTR No. 15.

Speed trace tolerances shall be the ones described in (a) and (b) of paragraph 9.4.1. of this GTR. The number of speed violations shall not exceed a number corresponding to 3% of the duration of the applicable test cycle (as defined above).

In case the vehicle cannot follow the speed trace of any of the cycles above, the friction brake share coefficients in Table 5.1. of this GTR shall be used by default.

7. Equivalency of Methods

Upon request of the vehicle manufacturer and if the equivalence criteria described in paragraph 7.3 are fulfilled, an alternative method as described in paragraph 5.2.4. may be used for the determination of the individual friction braking share coefficient instead of the reference methods described in paragraphs 5.2.1, 5.2.2 and 5.2.3.

7.1. Selection of Vehicle and Electrification Concept for Proof of Equivalence

The manufacturer shall demonstrate the equivalency of an alternative method for those vehicle categories of Table 5.1 for which the alternative method is requested to be applied. At least one vehicle for each vehicle category shall be used for such a demonstration.

7.2 Testing of the Alternative Method.

In order to demonstrate equivalency, the vehicle shall be equipped with brake torque meters, brake pressure transducers and/or sensors according to paragraph 6.1 and shall be subjected to the WLTP-Brake cycle according to the test sequence defined in paragraph 6.4.

7.3. Equivalency Criterion

The alternative method shall be deemed to be equivalent to the reference method if one of the following conditions is fulfilled

$$\left| \frac{c_{alt} - c}{c} \right| \leq [10\%] \quad (\text{Eq. 9})$$

$$|c_{alt} - c| \leq [x\%] \quad (\text{Eq. 10})$$

Where:

c_{alt} is the friction braking share coefficient measured through the alternative method and calculated according to Eq. 1

c is the friction braking share coefficient measured through the reference method and calculated according to Eq. 1

8. Equivalency of Test Cycle

As an alternative to derive the friction braking share coefficient from WLTP-Brake cycle, the manufacturer may choose to calculate it from WLTP-Brake-Trip10 cycle or from WLTC (Exhaust).

8.1. WLTP-Brake- Trip10

The friction braking share coefficient can be calculated from WLTP-Brake-Trip10 cycle as follows:

$$c = c_{trip10} \cdot k_{br-trip10} \quad (\text{Eq. 11})$$

where:

c_{trip10} is the friction braking share coefficient calculated on WLTP-Brake-Trip10 cycle according to Eq.1 where the friction work W_{brake} is calculated either according to Eq. 2, Eq. 3 or Eq. 4 or with an alternative method as described in Chapter 7.

$k_{br-trip10}$ is a correlation factor between WLTP-Brake cycle and WLTP-Brake-Trip10 cycle.

8.2. WLTC (Exhaust)

The friction braking share coefficient can be calculated from WLTC (Exhaust) as follows:

$$c = c_{exh} \cdot k_{exh} \quad (\text{Eq. 12})$$

where:

c_{exh} is the friction braking share coefficient calculated on WLTC (Exhaust) according to Eq.1 where the friction work W_{brake} is calculated either according to Eq. 2-4 or with an alternative method as described in Chapter 7.

k_{br-exh} is a correlation factor between WLTP-Brake cycle and WLTC (Exhaust).

If c_{exh} is lower than [x%], Eq. 12 shall not be used and the friction braking share coefficient shall be calculated either from WLTP-Brake cycle or from WLTP-Brake-Trip10 cycle according to paragraph 5.1, or 5.2, or 5.3.

8.3. Offset of the Friction Braking Share Coefficient (“Declaration”)

The friction braking share coefficient calculated according to paragraphs 8.1. and 8.2. may be increased by the manufacturer to cover the statistical and procedural uncertainties related to the use of the correlation factors in Eq. 11 or in Eq. 12.

9. Test Output

The reference measurement method for the determination and validation of the friction braking share coefficient used for type approval by the vehicle manufacturer shall be noted (see 5.2 for details).
