



Committee of Experts on the Transport of Dangerous Goods and on the Globally Harmonized System of Classification and Labelling of Chemicals

Sub-Committee of Experts on the Transport of Dangerous Goods

Sixty-second session

Geneva, 3-7 July 2023

Item 6 (c) of the provisional agenda

Miscellaneous proposals for amendments to the Model Regulations on the Transport of Dangerous Goods: portable tanks

Report from the informal working group on fibre reinforced plastics service equipment for portable tanks

Transmitted by the expert from the Russian Federation on behalf of the
informal working group on fibre reinforced plastics (FRP) service
equipment for portable tanks*

I. Introduction

1. The informal working group on FRP service equipment for portable tanks met in the inter-session period and discussed the comments to informal document INF.49 of the sixtieth session and document ST/SG/AC.10/C.3/2022/62 received during the session of the Sub-Committee as well as those received via correspondence and via teleconferences since December 2022. Summing up the comments, the main issues were regarding the clarification of definitions and justification of the fire resistance of the FRP service equipment and development of the specific test method.

II. Discussions in the working group

2. The definition of the shell and service equipment given in 6.7.2.1 and the definition of the FRP service equipment given in 6.9.3.1 of the *Model Regulations* have been comprehensively discussed and updated to exclude regulatory problems. Please see the proposed definitions in proposals 1 and 5.

3. Considering the comments received, the informal working group proposed a draft for a new section in the *Manual of Test and Criteria* on “Fire resistance test of FRP service equipment for portable tanks” (proposal 7), as well as consequential amendments in section 40 (proposal 6). A reference to the new section is added in 6.9.3.5.2 (d) (proposal 5).

* A/77/6 (Sect. 20), table 20.6



4. The informal working group will continue meeting via teleconferences during May and June 2023 to improve the proposed updates before the sixty-second session of the Sub-Committee.

III. Actions requested

5. The Sub-Committee is invited to consider the proposed updates of sub-chapter 6.9.3 and amendments to 6.7.2.1, 6.7.2.5.11, 6.9.1 and 6.9.2.5 in conjunction with the proposed new section 42 for the *Manual of Test and Criteria*.
6. The working group suggests having a two-day hybrid meeting in conjunction with the forthcoming sixty-second session of the Sub-Committee.

IV. Proposals to amend the Model Regulations

A. Proposal 1

7. In 6.7.2.1, amend the definition of *Service equipment* and *Shell* as follows (new text is underlined, deleted text in ~~striketrough~~):

Service equipment means measuring instruments and filling, discharge, venting, safety, heating, cooling and insulating devices, manlids and manhole covers, cleaning hatches and blind flanges.

Shell means the part of the portable tank which retains the substance intended for transport (tank proper), including openings ~~and their closures~~, but does not include service equipment or external structural equipment.

B. Proposal 2

8. Amend 6.7.2.5.11, to read as follows (new text is underlined, deleted text in ~~striketrough~~):

~~Ductile metals shall be used in the construction of valves and accessories. Service equipment shall be made of ductile metals and/or fibre reinforced plastic (FRP) in accordance with section 6.9.3. The use of other materials shall be agreed with the competent authority.~~

C. Proposal 3

9. Add a new 6.9.1.5 and a new footnote to read as follows:

6.9.1.5 The requirements of section 6.9.3 are applied to FRP service equipment for portable tanks with shells made of metallic or FRP materials¹ intended for the carriage of dangerous goods of Classes or Divisions 1, 3, 5.1, 6.1, 6.2, 8 and 9 by all modes of transport.

¹ *The requirements on FRP service equipment have initially been developed for both FPR and metallic shells and their application provides the appropriate level of safety. However, keeping in mind innovative aspects of the requirements provided the competent authority may consider the application of FRP service equipment with metal tanks.*

D. Proposal 4

10. In 6.9.2.5, amend the paragraph under the heading to read as follows (new text is underlined, deleted text in ~~striketrough~~):

Service equipment, bottom openings, pressure relief devices, gauging devices, supports, frameworks, lifting and tie-down attachments of portable tanks shall meet the requirements of 6.7.2.5 to 6.7.2.17. If any other metallic features are required to be integrated into the FRP shell, then the provisions of 6.9.2.3.8 shall apply. FRP service equipment in accordance with section 6.9.3 may be used.

E. Proposal 5

11. Add a new 6.9.3 as reproduced in annex I to this document.

V. Proposals to amend the Manual of Tests and Criteria

A. Proposal 6

12. Amend 40.1.1, to read as follows (new text is underlined, deleted text in ~~strikethrough~~):

Part IV of the Manual presents the United Nations schemes for dynamic and longitudinal impact testing of portable tanks and MEGCs (see section 41 of this Manual and 6.7.2.19.1, 6.7.3.15.1, 6.7.4.14.1 and 6.7.5.12.1 of the *Model Regulations*) and the requirements to the fire resistance test of service equipment made from fibre reinforced plastic (FRP) for portable tanks (see section 42 of this Manual and 6.9.2.7.1.5, and 6.9.3.5.2 (d) of the *Model Regulations*).

B. Proposal 7

13. Add a new section 42 as reproduced in annex II to this document.

Annex I

New section 6.9.3 for the *Model Regulations*

6.9.3 Requirements for design, construction, inspection and testing of FRP service equipment for portables tanks

6.9.3.1 Definitions

For the purposes of this section, the definitions in 6.7.2.1 and 6.9.2.1 apply except for definitions related to metal materials for the construction of the service equipment of portable tanks.

Additionally, the following definitions apply to FRP service equipment.

FRP service equipment means measuring instruments and filling, discharge, venting, safety, heating, cooling and insulating devices, manlids and manhole covers, cleaning hatches and blind flanges made of FRP including gate and seal assemblies, and metallic parts, e.g. springs, fixings, applicable to the both metallic and FPR shells of the portable tanks.

Injection moulding means a process of melting plastic pellets (thermosetting/thermoplastic polymers) that once malleable enough, are injected at pressure into a mould cavity, which fills and solidifies to produce the final product.

Compression moulding means a process for producing composite parts in a wide range of volumes typically employing a matched metal tool in a heated (normally hydraulic) press to consolidate sheet materials or moulding compounds at relatively high pressures.

Reinforced reaction injection moulding (RRIM) means a process of mixing of two or more resins together in the mixing chamber to form a thermosetting polymer under high pressure. Reinforcement agents like glass fibres or mica are added to the mixture. Then, the resin mixture is metered into a mould with the help of high-pressure pumps or injection cylinders.

Coupon-sample means an FRP sample fabricated and tested in accordance with national and/or international standards to determine design allowables.

Inspection-sample means a sample cut out from the FRP service equipment to establish the identity of the serial FRP device to the prototype.

FRP constituents means reinforcement fibres and/or particles, thermoset or thermoplastic polymer (matrix), adhesives, and additives.

6.9.3.2 General design and construction requirements

6.9.3.2.1 For the purposes of this section, the requirements of 6.7.2.2.11, 6.7.2.5.1 to 6.7.2.5.6, 6.7.2.5.10, 6.7.2.6.3, 6.7.2.8.2, 6.7.2.8.3, 6.7.2.9 and 6.7.2.12 to 6.7.2.15 shall be applied to FRP service equipment including metallic parts (springs, fixings, etc.). FRP service equipment shall be designed and constructed in accordance with the requirements of a pressure vessel code and national and international standards, applicable to FRP materials and recognized by the competent authority.

6.9.3.2.2 Manufacturer's quality system

6.9.3.2.2.1 FRP service equipment manufacturers shall have a documented quality system ensuring conformity of every item of the serial production of FRP service equipment to the approved prototype. The Quality Assurance Program shall be submitted to the competent authority for approval. All manufacturer's suppliers of material and components for FRP service equipment shall have a documented quality system. The quality system shall be developed in compliance with the general principles of international and national quality standards.

6.9.3.2.2 The applicable provisions of 6.9.2.2.2 shall apply to FRP service equipment manufacturer's quality system.

6.9.3.2.3 *FRP service equipment*

6.9.3.2.3.1 FRP service equipment shall have appropriate rigid joints to the portable tank shell. The connections shall cause no dangerous local stress concentrations in the shell and the equipment exceeding the design allowables for all operating and test conditions.

6.9.3.2.3.2 FRP service equipment shall be made of suitable materials, capable of operating within a minimum design temperature range of -40 °C to +50 °C, unless temperature ranges are specified for specific more severe climatic or operating conditions (e.g. heating elements), by the competent authority of the country where the transport operation is being performed.

6.9.3.2.3.3 FRP service equipment and its bolted and/or glued joints of the portable tank shell shall be designed and constructed to withstand a test pressure which is not less than 1.5 times the design pressure. Specific provisions are stated for certain substances in the applicable portable tank instruction indicated in column 13 of the Dangerous Goods List and described in 4.2.5, or by the portable tank special provision indicated in column 14 of the Dangerous Goods List and described in 4.2.5.3.

6.9.3.2.3.4 FRP service equipment shall withstand vibration, service impacts, exposure to substance temperature and environmental effects.

6.9.3.2.3.5 Design calculations for FRP service equipment and its joints to the portable tank shell shall be performed by the finite element method or the applicable pressure vessel code.

6.9.3.2.3.6 FRP service equipment shall meet the same requirements as given in 6.9.2.2.3.14 for the carriage of substances with a flash point of not more than 60 °C.

6.9.3.2.4 *Materials*

6.9.3.2.4.1 Resins

The processing of the resin mixture shall be carried out in strict compliance with the recommendations of the supplier. This concerns mainly the use of hardeners, initiators and accelerators. The resins can be:

- (a) Unsaturated polyester resins;
- (b) Vinyl ester resins;
- (c) Epoxy resins;
- (d) Phenolic resins; or
- (e) Thermoplastic resins.

The heat distortion temperature (HDT) of the resin, determined in accordance with ISO 75-1:2013 and ISO 75-2:2013 shall be at least 20°C higher than the maximum service temperature of the tank, but shall in any case not be lower than 70°C.

6.9.3.2.4.2 Additives

Additives necessary for the treatment of the resin, such as catalysts, accelerators, hardeners and thixotropic substances as well as materials used to improve the FRP service equipment, such as fillers, colours, pigments, etc. shall not cause weakening of the material, taking into account lifetime and temperature expectancy of the design.

6.9.3.2.4.3 Reinforcement fibres

Reinforcement fibres shall be chopped or continuous fibres of several types.

6.9.3.2.4.4 FRP service equipment shall be manufactured by compression moulding, injection moulding, reinforced reaction injection moulding or hand lay-up. Other manufacturing technologies may be applied with the agreement of the competent authority.

6.9.3.3 *Design criteria*

6.9.3.3.1 FRP service equipment shall be of a design capable of being stress-analyzed mathematically or experimentally by resistance strain gauges, or by other methods approved by the competent authority.

6.9.3.3.2 FRP service equipment shall be designed and manufactured to withstand the test pressures specified in 6.7.2.5.6 and 6.9.3.2.3.3.

6.9.3.3.3 At the specified test pressure, the maximum tensile relative deformation measured in mm/mm in the FRP service equipment shall not result in the formation of microcracks, and therefore not be greater than the first measured point of elongation-based fracture or damage of the resin, measured during the tensile tests prescribed under 6.9.2.7.1.2 (c) and 6.9.3.4.1.1.

6.9.3.3.4 For the internal test pressure specified in 6.9.3.2.3.3, the failure criteria (*FC*) shall not exceed the following value:

$$FC \leq \frac{1}{K}$$

where:

$$K = K_0 \times K_1 \times K_2 \times K_3 \times K_4 \times K_5$$

where:

K shall have a minimum value of 4.

K_0, K_1, K_2, K_3, K_4 are given in 6.9.2.3.4.

K_5 is a factor related to the deterioration in the material properties due to effects of salt fog spray and ultraviolet exposure. It shall be determined by the formula:

$$K_5 = \frac{\sigma_n}{\sigma_{eff}}$$

where:

σ_n is the nominal (under normal conditions) tensile strength of the FRP material and σ_{eff} is the tensile strength of the material after consecutive salt fog exposure in accordance with ISO 12944-2:2017, ISO 12944-6:2018, 168 hours at $+(35 \pm 2)$ °C and ultraviolet exposure in accordance with ISO 4892-2, 168 hours at $+(23 \pm 2)$ °C.

$\sigma_{eff} = \min(\sigma_{eff1}, \sigma_{eff2} \dots \sigma)$, where 1, 2, ... k are identifiers of substances approved for transportation by the given portable tank. If a protective coating is used, the samples with the coating shall be fabricated and tested.

A design validation exercise using numerical analysis and a suitable composite failure criteria is to be undertaken to verify that the FRP service equipment are below the allowables. Suitable composite failure criteria include, but are not limited to Strain Invariant Failure Theory, Maximum Strain, or Maximum Stress. Other relations for the strength criteria are allowed upon agreement with the competent authority. The method, a proof of suitability for the chosen failure criteria with a list of relevant experiments for all parameters used in

the chosen failure criteria, and results of this design validation exercise are to be submitted to the competent authority.

The parameters used in the chosen failure criteria are to be determined using the relevant experiments and the maximum strain in tension prescribed in 6.9.2.3.5, combined with factor of safety K . At least all experiments defined in 6.9.3.4.2 must be performed.

6.9.3.3.5 Check calculations of the strength for FRP service equipment and its joints to the portable tank shell shall be performed by finite element method. Treatment of singularities shall be undertaken using an appropriate method according to the applicable pressure vessel code.

6.9.3.4 Material testing

6.9.3.4.1 Resins

Where neat resin specimens are used for the materials testing set out in 6.9.3.4.1.1 and 6.9.3.4.1.2, the resin shall be processed in the same manner as when it is used in a composite material, taking into account mix ratios, resin additives, post-cure, and any other parameters deemed relevant to cure.

6.9.3.4.1.1 Resin tensile elongation shall be tested according to ISO 527-2:2012.

6.9.3.4.1.2 Heat distortion temperature shall be tested according to ISO 75-1:2013 and ISO 75-2:2013.

6.9.3.4.2 Coupon-samples

Coupon-samples shall be manufactured by the same technology as the appropriate FRP service equipment.

6.9.3.4.2.1 Ultimate tensile strength and elongation shall be tested according to ISO 527-4:2021.

6.9.3.4.2.2 Determination of compressive properties shall be tested in the in-plane direction according to ISO 14126:1999 + Cor 1:2001.

6.9.3.4.2.3 Determination of the in-plane shear stress/strain response and shear modulus shall be tested according to ISO 20337:2018.

6.9.3.4.2.4 Mass density shall be tested according to ISO 1183-1:2019.

6.9.3.4.2.5 Mass content and composition of the reinforcement fibres shall be tested according to ISO 1172:1996. The fibre mass content of the coupon-samples shall be between 90 % and 100 % of the minimum fibre mass content specified for the appropriate FRP service equipment and obtained from testing of the inspection-samples.

6.9.3.4.2.6 The chemical compatibility with the transported substances shall be tested according to 6.9.2.7.1.3.

6.9.3.4.2.7 Hardness shall be tested according to ISO 868:2003.

6.9.3.4.2.8 Creep factor α shall be measured according to procedure prescribed by 6.9.2.7.1.2 (e). The test samples shall be taken according to ISO 14125:1998.

6.9.3.4.2.9 Aging factor β shall be determined according to the procedure prescribed by 6.9.2.7.1.2 (f). The test samples shall be taken according to ISO 14125:1998. This testing may be undertaken on either pristine samples or on samples pre-subjected to salt fog spray exposure conditioning as outlined in 6.9.3.2.4.10.

6.9.3.4.2.10 Salt fog exposure test shall be determined in accordance with ISO 12944-2:2017, ISO 12944-6:2018, 168 hours at $+(35 \pm 2) ^\circ\text{C}$.

6.9.3.4.2.11 Ultraviolet exposure test shall be determined in accordance with ISO 4892-2:2013, 168 hours at $+(23 \pm 2)$ °C.

6.9.3.4.3 The additional material tests shall be carried out for determination of material properties required for design calculation.

6.9.3.4.3.1 Flexural strength shall be measured according to ISO 14125:1998.

6.9.3.4.3.2 Bearing test shall be determined according to ISO 12815:2013.

6.9.3.4.4 *Inspection-samples*

Prior to testing all coatings shall be removed from the samples. The tests shall cover 6.9.3.4.2.1 to 6.9.3.4.2.8.

6.9.3.5 *Design approval*

6.9.3.5.1 The competent authority or its authorized body shall issue the type approval certificate for FRP service equipment. This certificate shall attest that the design has been surveyed by the authority and is suitable for its intended purpose and meets the requirements of this chapter. The certificate shall also have a reference that prototype testing was carried out according to 6.9.3.5.2, the information on the substances allowed for transportation, body and seal materials and certificate number.

6.9.3.5.2 The FRP service equipment prototype test report shall include at least the following:

- (a) Results of the material tests used for fabrication of FRP service equipment in accordance with 6.9.3.4.1 to 6.9.3.4.3.
- (b) Results of tests according to ISO 4126-1:2013 for the appropriate relief devices.
- (c) Results of the pressure tests carried out in accordance with relevant ISO standards, where applicable, or according to procedure approved by the competent authority. The test pressure shall not be less than the highest of four times the maximum allowable working pressure (MAWP) of the shell or four times the pressure to which it may be subjected in service by the action of a pump or other device (except pressure relief devices).
- (d) A representative prototype of FRP service equipment shall be subjected to the fire test prescribed in the *Manual of Tests and Criteria*, part IV, section 42.
- (e) Results of the electrical resistance tests according to a procedure recognized by the competent authority.
- (f) Results of the other tests prescribed in applicable pressure equipment standards or codes in agreement with the competent authority.

6.9.3.5.3 A service life inspection program shall be established, which shall be a part of the operation manual, to monitor the condition of the FRP service equipment at periodic inspections. The service life inspection program shall be approved by the competent authority.

6.9.3.6 *Inspection and testing*

6.9.3.6.1 FRP service equipment shall be inspected and tested before being put into service. The initial inspection and test after manufacture shall include a check of the design characteristics and an external examination of FRP service equipment with due regard to the substances to be transported, and a pressure test. Before putting the FRP service equipment into service, a leakproofness test and a test of the satisfactory operation shall also be

performed. Relief valves shall be tested for opening/closing pressure before installation. The initial inspection and testing program shall be approved by the competent authority.

6.9.3.6.2 Periodical inspection and testing of FRP service equipment shall be carried out during inspection of the portable tank according to provisions of 6.7.2.19.2, 6.7.2.19.4, and 6.7.2.19.5 or 6.9.2.8.1 according to the service life inspection program approved by the competent authority.

6.9.3.6.3 The inspections and tests in 6.9.3.6.1 and 6.9.3.6.2 shall be performed or witnessed by an expert approved by the competent authority or its authorized body.

6.9.3.6.4 Repair work of FRP service equipment shall be limited to replacement of damaged components by components covered by the type approval of the service equipment.

6.9.3.7 Marking

6.9.3.7.1 Marking of relief devices

Each relief device shall be marked as follows:

- (a) name of the manufacturer and the serial number of the equipment;
- (b) name of body and seal materials;
- (c) type approval certificate number;
- (d) the pressure at which the device is set to discharge (MPa or bar);
- (e) the allowable tolerance at the discharge pressure for spring-loaded devices;
- (f) the rated flow capacity of spring-loaded pressure relief devices under normal conditions (external pressure is 1 bar and ambient temperature is 0 °C) in standard (normal) cubic meters of air per second, m³/s (determined according to 6.7.2.13.2);
- (g) cross-sectional area of spring-loaded pressure relief devices, mm²;
- (h) maximum allowable working pressure (MAWP, MPa or bar);
- (i) external design pressure (if relevant, MPa or bar); and
- (j) design temperature range.

6.9.3.7.2 Marking of stop valves

Each stop valves shall be marked as follows:

- (a) name of the manufacturer and the serial number of the equipment;
- (b) name of body and seal materials.
- (c) type approval certificate number;
- (d) designation of the stop device;
- (e) nominal diameter, mm;
- (f) maximum allowable working pressure (MAWP, MPa or bar);
- (g) direction of medium flow; and
- (h) design temperature range.

6.9.3.7.3 *Marking of manlids and manhole covers*

Each manlid and manhole cover shall be marked as follows:

- (a) name of the manufacturer and the serial number of the equipment;
- (b) type approval certificate number;
- (c) name of body and seal materials;
- (d) nominal diameter, mm;
- (e) maximum allowable working pressure (MAWP, MPa or bar);
- (f) test pressure (MPa or bar); and
- (g) design temperature range.

Annex II

Section 42

Fire resistance test of FRP service equipment for portable tanks

42.1 General

42.1.1 This test method is intended to prove the fire resistance of FRP service equipment for portable tanks which meet the requirements of 6.7.2 or 6.9.2 of the *Model Regulations*.

42.1.2 The representative prototype of FRP service equipment meeting the definition of 6.9.3.1 of the *Model Regulations* shall be subjected to and satisfy the requirements of the fire resistance test. The fire resistance test shall be conducted by test facilities approved by the competent authorities.

42.2 Definitions

Test specimen means an instance of FRP service equipment including gate and seal assemblies subjected to the fire resistance test.

Relevant definitions of ISO 21843:2018 and chapters 6.7.2, 6.9.2 and 6.9.3 of the *Model Regulations* are applicable to this section.

42.3 Test method

42.3.1 The fire resistance test is carried out for the test specimen installed in a closed position, filled with water with initial temperature of 20 °C, under a pressure of 60 kPa at the equipment sealing surface, and exposures to flame for at least 30 minutes. The test specimen must be completely engulfed in the flame including the gate and seal assemblies. The general test scheme is given in figure 42.3.1. In the event that the test specimen is an item of equipment which is not intended to be the outermost closure in a multi-closure system (such as a valve), then the test specimen may be equipped with a blind flange, at its outermost interface which would otherwise be exposed to flame during the test.

42.3.2 The fire exposure parameters shall comply with paragraph 6.9.2.7.1.5.1 of the *Model Regulations*. The fire shall be equivalent to a theoretical fire with a flame temperature of 800 °C, emissivity of 0.9 and a minimum net heat flux of 75 kW/m² calibrated according to ISO 21843:2018.

42.3.3 The intensity of heat exposure shall be measured using temperature and heat flux sensors in accordance with the requirements of ISO 21843-2018.

42.3.4 During the test, one or several limit states (if any) listed in 42.6.1 are sequentially registered.

42.3.5 After the fire exposure and cooling the test specimen is subjected to a hydraulic test under 60 kPa to check the strength of the body, operation of the "open-closed" cycle (if any) and leakproof test before and after operation of the "open-closed" cycle.

Figure 42.3.1: Fire resistance test scheme

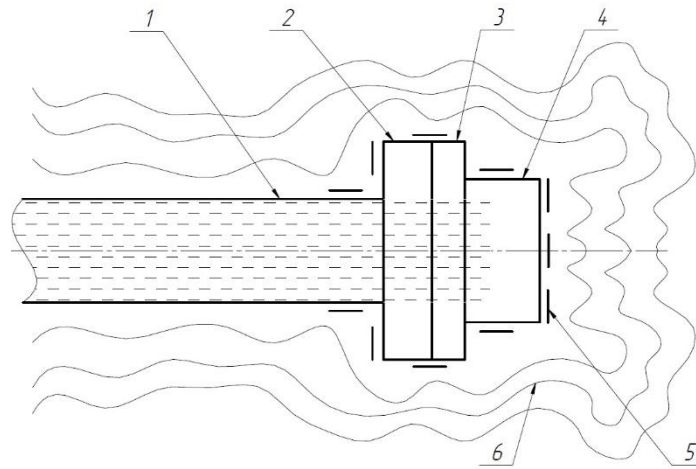

A

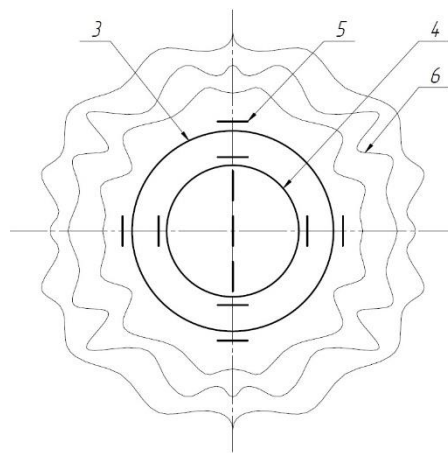

B

-
- | | |
|---|--|
| (A) Side view | (B) End-face view |
| (1) Pressure system with water supply | (2) Fixture to join the test specimen to the pressure system |
| (3) Flange of the test specimen to join to the tank shell | (4) Test specimen |
| (5) Temperature and heat flow measuring system | (6) Flame |
-

42.4 Test apparatus

42.4.1 General requirements

42.4.1.1 The fire resistance test bed shall include:

- (a) a fire chamber with dimensions sufficient to accommodate the test specimen and the temperature and heat flux measuring system;
- (b) a fuel supply and combustion system;
- (c) a pressure system with water supply ((1) in figure 42.3.1);
- (d) a fixture to join the test specimen to the test bed ((2) in figure 42.3.1); and
- (e) the temperature and heat flux measuring system ((5) in figure 42.3.1) according to ISO 21843:2018.

42.4.1.2 The specific types of testing equipment can be modified and supplemented in accordance with the requirements of the testing laboratory.

42.4.1.3 The test specimen is cooled down to room temperature by water supplied through it.

42.4.1.4 The test bed facilities shall not expose the test specimen to external influences that can affect the test results.

42.4.1.5 The heat regime shall be provided by burning liquid fuel or gas.

42.4.1.6 The test bed shall ensure uniform flame coverage of the test specimen.

42.4.1.7 The firing chamber shall provide a horizontal gap between any part of the test specimen and its own shell of at least 150 mm.

42.4.1.8 The fire source (nozzles) shall be at least 150 mm away from the test specimen and temperature sensors and shall provide sufficient power to ensure that the test specimen is completely engulfed in flame.

42.4.1.9 The fuel supply and combustion system shall be controlled.

42.4.2 Requirements of the measuring system

42.4.2.1 During the test the following parameters shall be measured and controlled:

- (a) temperature and heat flux on the surface of the test specimen;
- (b) time of occurrence of the limit states and their type (if any);
- (c) internal pressure during fire and cooling (pressure gauge records);
- (d) leakiness of the external and internal seals of the test specimen.

42.4.2.2 The general scheme of installation of the test specimen and temperature and heat flow sensors is shown in figure 42.3.1. The test installation shall be certified. Measurement errors shall not be more than:

± 3 % when measuring pressures;

+ 5 % when measuring temperature and heat flux;

+ 2 % when measuring time.

42.4.2.3 The measurement system can be changed and supplemented in accordance with the specific requirements of the developers of the test bed in agreement with the competent authority.

42.5 Test procedure

42.5.1 The temperature and heat flux sensors shall be installed and calibrated according to ISO 21843:2018. The fuel supply and combustion system shall be tested and debugged.

42.5.2 Before the test, the test specimen shall be installed in a partially open position, opening the water supply valve and drain valve (if available) to fill the system with water and displace air.

42.5.3 After the system is completely filled with water, the system shall be loaded with a pressure of 1.5 MAWP at a temperature of 20 °C. Then the leakproofness of the test specimen and pipelines shall be checked. Relieving pressure to the value of 60 kPa.

42.5.4 The fuel supply to the burners shall be opened, ignited and the flame be adjusted with a control valve. The fire parameters shall be maintained in accordance with 42.3.2 for 30 minutes. The temperature and heat flux are recorded every 30 seconds with separate records for each sensor during the test.

42.5.5 The fuel supply shall be turned off after the test (not more than 30 minutes). The volume of water remaining inside the test assembly is immediately measured and the total leakage through the gate and seals of the test specimen is calculated.

42.5.6 The test specimen shall be removed after complete cooling (wall temperature less than 50 °C). At least 3 "open-closed" cycles (if any) shall be performed. Then the test specimen shall be subjected to hydraulic and leakproofness tests at 60 kPa.

42.6 Performance criteria

42.6.1 The occurrence of the following limit states of the test specimen is not allowed during the thermal exposure and cooling:

- (a) leakage of the gate;
- (b) loss of seal leakproofness;
- (c) leakage of fixed and moveable joints;
- (d) loss of displacement ability of moving parts when operating cycles "open-closed";
- (e) changes in geometric shapes and sizes of parts that interfere with normal functionality of the test specimen;
- (f) appearance of cracks and burnouts.

42.6.2 At least three "open-closed" cycles (if any) shall be run in the presence of a 60 kPa drop on the test specimen gate.

42.6.3 If the conditions in 42.6.1 and 42.6.2 are met, the test specimen is considered to have passed the fire resistance test.

42.7 Test report

The test report shall contain:

- (a) the name of the organization conducting the tests;
- (b) the name of the manufacturer of the FRP service equipment;
- (c) the date of the fire resistance tests;
- (d) a description of the FRP service equipment (for example, a pressure relief valve), including dimensions, weight, diameter of the gate section, body and lid materials, seal material;
- (e) a recording of the controlled parameters according to paragraph 42.4.2.1 and the results of their processing and analysis;
- (f) the results of visual observations;
- (g) a description of the damage or failure (if any) and the conditions in which the failure occurred;
- (h) the start time of the test (i.e. the ignition of the burners);
- (i) the time of occurrence of the limit states specified in paragraph 42.6.1 (if any);
- (j) the conclusion on the compliance or non-compliance of the FRP service equipment with the requirements of subsection 42.6.

42.8 Safety requirements

As the fire resistance test of the FRP service equipment is potentially dangerous, the safety of personnel shall be assured. Considering the possibility of damage and failure of the test, protective screens and other appropriate means to protect personnel shall be used.
