

Proposal for the 01 Series of Amendments to UN Regulation No. 145 (ISOFIX anchorage systems, ISOFIX top tether anchorages and i-Size) *

Submitted by the expert from the Netherlands

The text reproduced below was prepared by the Ad Hoc Group on Child Restraint Systems, aiming to introduce definitions, requirements and a test procedure for lower tether anchorages. The modifications to the existing text of the UN Regulation by document ECE/TRANS/WP.29/GRSP/2023/12 are marked in “bold black“ for new or strikethrough for deleted characters. The modifications made by this document are marked in “**(bold) blue**” for new or strikethrough for deleted characters.

* In accordance with the programme of work of the Inland Transport Committee for 2023 as outlined in proposed programme budget for 2023 (A/77/6 (Sect. 20), table 20.6), the World Forum will develop, harmonize and update UN Regulations in order to enhance the performance of vehicles. The present document is submitted in conformity with that mandate.

I. Proposal

Contents, list of annexes, amend to read:

"Contents

Page

Regulation

1.	Scope	
2.	Definitions.....	
3.	Application for Approval	
4.	Approval	
5.	Specifications	
6.	Tests	
7.	Modifications and extension of approval of the vehicle type	
8.	Conformity of production	
9.	Penalties for non-conformity of production	
10.	Production definitively discontinued	
11.	Names and addresses of Technical Services responsible for conducting approval tests, and of Type Approval Authorities	

Annexes

1	Communication	
2	Arrangements of the approval mark	
3	Procedure for determining the "H" point and the actual torso angle for seating positions in motor vehicles.....	
	Appendix 1 - Description of the three-dimensional "H" point machine (3-D H machine)	
	Appendix 2 - Three-dimensional reference system	
	Appendix 3 - Reference data concerning seating positions.....	
4	ISOFIX anchorages systems and ISOFIX top tether anchorages.....	
5	i-Size seating position	
6	Lower Tether Anchorage Zone and the Position of the Force Direction Reference Point	
7	ISO/R2 Positioning Procedure for non-ISOFIX/i-Size Seating Position	"

Paragraph 1, amend to read:

"1. Scope

This Regulation applies to:

- (a) Vehicles of category M₁ with regard to their ISOFIX anchorage systems, ~~and~~ their ISOFIX top tether anchorages **and lower tether anchorages** intended for child restraint systems. Other categories of vehicles fitted with ISOFIX anchorages **and/or lower tether anchorages** have also to comply with the provisions of this Regulation;
- (b) Vehicles of any category with regard to their i-Size seating positions, if any are defined by the vehicle manufacturer."

Insert new paragraphs 2.25. to 2.31., to read:

- "2.25. **"Lower tether anchorage (LTA)" is an anchorage on the vehicle seat track, or on or close to the vehicle floor to which a lower tether bracket can be attached. The lower tether bracket may or may not be part of the vehicle approval.**
- 2.26. **"Lower tether" is a type of anti-rotation device intended to restrict the rearward rotation of a rearward-facing (E)CRS.**
- 2.27. **"Lower tether strap" is a webbing strap (or equivalent) which extends from the back of a Specific Vehicle (E)CRS to the lower tether anchorage in the vehicle and which is equipped with an adjustment device, a tensioning-relieving device and a lower tether connector.**
- 2.28. **"Lower tether connector" means a device intended to be attached to a lower tether bracket.**
- 2.29. **"Lower tether hook" means a connector typically used to attach a lower tether strap to a lower tether bracket, and which is the same and has the same dimensions as the ISOFIX top tether hook as defined in figure 3 of Annex 4 of UN Regulation No. 145.**
- 2.30 **"Lower tether bracket" means the bracket that is attached to or integrated with the lower tether anchorage.**
- 2.31. **"Generic lower tether bracket" means the generic bracket provided by the ECRS manufacturer together with the ECRS, to be attached to the LTA as indicated by the vehicle manufacturer.**
- 2.32 **"FDRP" means the Force Direction Reference Point, located at the front of the ISO/R2 envelope at a height of 300 mm from the bottom. The FDRP lateral position coincides with the centreline of the ISO/R2 envelope.**

Paragraphs 3 to 3.3., amend to read:

"3. Application for Approval

- 3.1. The application for approval of a vehicle type with regard, the ISOFIX anchorages systems, the ISOFIX top tether anchorages, **the lower tether anchorages** and i-Size seating positions, if any, shall be submitted by the vehicle manufacturer or by his duly accredited representative.
- 3.2. It shall be accompanied by the under mentioned documents in triplicate and by the following particulars:
 - 3.2.1. Drawings of the general vehicle structure on an appropriate scale, showing the positions of the ISOFIX anchorage systems, of ISOFIX top tether anchorages **and/or lower tether anchorages including lower tether brackets (if provided by the manufacturer)** if any and in case of i-Size seating positions

- or applications of a support leg in combination with non-ISOFIX/i-Size seating positions**, the vehicle floor contact surface and detailed drawings of the ISOFIX anchorages systems if any, of the ISOFIX top tether anchorages **and/or lower tether anchorages including lower tether brackets (if provided by the manufacturer)** if any, and of the points to which they are attached and in case of i-Size seating positions **or applications of a support leg in combination with non-ISOFIX/i-Size seating positions**, the vehicle floor contact surface;
- 3.2.2. A specification of the materials used which may affect the strength of the ISOFIX anchorages systems, ~~and~~ ISOFIX top tether anchorages **and/or lower tether anchorages** if any and in case of i-Size seating positions **or applications of a support leg in combination with non-ISOFIX/i-Size seating positions**, the vehicle floor contact surface;
- 3.2.3. A technical description of the ISOFIX anchorages systems, ~~and~~ ISOFIX top tether anchorages **and/or lower tether anchorages including lower tether brackets (if provided by the manufacturer)** if any;
- 3.2.4. In the case of the ISOFIX anchorages systems and of ISOFIX top tether anchorages **and/or lower tether anchorages** if any affixed to the seat structure:
- 3.2.4.1. Detailed description of the vehicle type with regard to the design of the seats, of the seat anchorages and of their adjustment and locking systems;
- 3.2.4.2. Drawings, on an appropriate scale and in sufficient detail, of the seats, of their anchorage to the vehicle, and of their adjustment and locking systems.
- 3.3. At the option of the manufacturer, a vehicle representative of the vehicle type to be approved by the technical service conducting approval tests, or the parts of the vehicle considered essential for the ISOFIX anchorages systems, for ISOFIX top tether anchorages **and/or lower tether anchorages** if any, and in case of i-Size seating positions **or applications of a support leg in combination with non-ISOFIX/i-Size seating positions**, the vehicle floor contact surface test, shall be submitted to the technical service."

Paragraph 5.3.6., amend to read:

- "5.3.6. Notwithstanding paragraph 5.3.1. in case of integrated "built in" child restraint system(s) the number of ISOFIX positions to be provided shall be at least two minus the number of the integrated "built in" child restraint system(s) of mass groups 0, or 0+, or 1 **or of the specific vehicle built-in Enhanced Child Restraint Systems for use by children up to 105 cm height.**"

Insert new paragraphs 5.4. to 5.4.3.3., to read:

- 5.4 Lower Tether Anchorages (LTA)**
- 5.4.1. Applicability**
- 5.4.1.1. A vehicle type may be equipped with lower tether anchorages meeting the requirements of this Regulation.
- 5.4.1.2. A vehicle type may be approved without the lower tether brackets provided and/or installed by the vehicle manufacturer. In such case the lower tether anchorages as specified by the vehicle manufacturer shall be approved for use in combination with generic lower tether brackets conforming to the specifications in UN Regulation No. 129.
- 5.4.2. Number and Positioning**
- 5.4.2.1. Each intended (E)CRS position may be provided with a single or two LTAs, located within the zones shown in figures 1 to 3 of Annex 6 and according to the following specifications.

- 5.4.2.1.1. For ISOFIX seating positions, a reference point for measurements is obtained by installing the ISO/R2 fixture in accordance with UN Regulation No. 16, in the vehicle seat. If adjustable, the seat shall be adjusted to its rearmost position.
- 5.4.2.1.2. For non-ISOFIX seating positions, the reference point for measurements shall be obtained by installing the ISO/R2 fixture in the vehicle seat, using the envelope positioning procedure in Annex 7. If adjustable, the seat shall be adjusted to its rearmost position.
- ~~5.4.2.1.3. If two lower tether anchorages are chosen, they shall be positioned with a minimum distance of [280 mm] for the respective ECRS position.~~
- 5.4.2.1.3. If two lower tether anchorages are chosen, they do not need to be symmetrically positioned with respect to the centreline through the fixture. However,:
- 5.4.2.1.3.1. Anchorages shall not be positioned on the same side of the fixture centreline; and
- 5.4.2.1.3.2. The distance between the centreline of the anchorages and the centreline of the fixture should be no more than 200 mm measured perpendicularly.
- 5.4.2.1.4. If a single lower tether anchorage is chosen for the seating position, it shall be symmetrically positioned with respect to the centreline through the fixture within an offset of ± 50 mm.
- 5.4.2.2. Lower tether anchorages may be placed under the vehicle floor, for example in a storage compartment under a floor cover, if such a positioning can be regarded as acceptable from a usability perspective, in agreement with the Technical Service and Type Approval Authority.
- 5.4.2.3. The zone intended for a support leg as defined in paragraphs 5.2.4.2. and 5.2.4.4. (the support leg foot assessment volume) may not be used for lower tether anchorages.
- 5.4.2.4. Rerouting of the lower tether strap path is allowed, although it should be ensured that it does not affect the function of the lower tethers or sensitive parts of the vehicle interior.
- 5.4.3. Design
- 5.4.3.1. The lower tether anchorage bracket shall have an opening (square, circular, or semi-circular) and clearance space to allow attachment with a standard lower tether connector, in accordance with Annex 4, figure 3.
- 5.4.3.2. For anchorages designed to be used for two adjacent (E)CRS positions, the opening and clearance space of the bracket shall allow for simultaneous attachment with two standard lower tether connectors.
- 5.4.3.3. LTA shall be designed to avoid inadvertent injuries to passengers, for example designed to minimise sharp edges and protrusions. LTAs in compliance with UN R21 and/or UN 17 are regarded as to comply with this paragraph"

Paragraphs 6.2.4.3. to 6.2.4.5., amend to read:

"6.2.4.3. Tests of ISOFIX anchorages system only:

6.2.4.3.1. Forward direction force test:

Horizontal longitudinal excursion (after pre-load) of point X of SFAD during application of the $8 \text{ kN} \pm 0.25 \text{ kN}$ force shall be limited to 125 mm and permanent deformation including partial rupture or breakage of any ISOFIX low anchorage or surrounding area shall not constitute failure if the required force is sustained for the specified time **and the deformation does not constitute an additional risk to adjacent vehicle safety components in agreement with the Technical Service and Type Approval Authority.**

6.2.4.3.2. Oblique direction force test:

Excursion in the direction of the force (after pre-load) of point X of SFAD during application of the $5 \text{ kN} \pm 0.25 \text{ kN}$ force shall be limited to 125 mm and permanent deformation including partial rupture or breakage of any ISOFIX low anchorage or surrounding area shall not constitute failure if the required force is sustained for the specified time **and the deformation does not constitute an additional risk to adjacent vehicle safety components in agreement with the Technical Service and Type Approval Authority.**

6.2.4.4. Test of ISOFIX anchorages systems and ISOFIX top tether anchorage:

A tension pre-load of $50 \text{ N} \pm 5 \text{ N}$ must be applied between the SFAD and the top-tether anchorage. Horizontal excursion (after pre-load) of point X during application of the $8 \text{ kN} \pm 0.25 \text{ kN}$ force shall be limited to 125 mm and permanent deformation including partial rupture or breakage of any ISOFIX low anchorage and top tether anchorage, or surrounding area shall not constitute failure if the required force is sustained for the specified time **and the deformation does not constitute an additional risk to adjacent vehicle safety components in agreement with the Technical Service and Type Approval Authority.**

6.2.4.5. Test for i-Size seating positions:

In addition to the tests specified in paragraphs 6.2.4.3. and 6.2.4.4., a test with a modified static force application device, which consists of a SFAD and includes a support leg test probe as defined in Figure 3 of Annex 5, shall be performed. The support leg test device shall be adjusted in length and width to assess the vehicle floor contact surface, as defined in paragraph 5.2.4.2. (see also Figures 1 and 2 of Annex 5 to this Regulation). The height of the support leg test device shall be adjusted in a way that the foot of the support leg test device is in contact with the upper surface of the vehicle floor. In case of incremental height adjustment, the first notch where the foot rests stable on the floor shall be chosen; in case of a non-incremental/continuous adjustment of the support leg test device height, the pitch angle of the SFAD shall be increased by 1.5 ± 0.5 degrees due to the height adjustment of the support leg test device.

The horizontal excursion (after pre-load) of point X of the SFAD during application of the $8 \text{ kN} \pm 0.25 \text{ kN}$ force shall be limited to 125 mm and permanent deformation including partial rupture or breakage of any ISOFIX low anchorage and the vehicle floor contact surface, or surrounding area shall not constitute failure if the required force is sustained for the specified time **and the deformation does not constitute an additional risk to adjacent vehicle safety components in agreement with the Technical Service and Type Approval Authority."**

Insert new paragraphs 6.3. to 6.3.5., to read:

6.3. Lower tether anchorage strength requirements

6.3.1. In case the lower tether anchorages are part of, or attached to, a seat which has been type approved according to paragraph 6.4.4. of UN Regulation No. 14, the test may be performed on a component level (e.g. seat rail).

6.3.2. During the strength test, all relevant interior components (e.g. seat in front of (E)CRS position) shall be mounted. If not otherwise recommended by the vehicle manufacturer, adjustable seats should be positioned as follows:

6.3.2.1. Longitudinally, to the closest position of mid-position between the rearmost position and the foremost position;

6.3.2.2. Vertically, to the closest position of the mid position of its height adjustment.

- 6.3.3. Apply a force of $2,500\text{ N} \pm 50\text{ N}$ to each lower tether anchorage bracket, by means of a representative lower tether strap $38\text{ mm} \pm 3\text{ mm}$ wide that is fitted at one end with suitable hardware for applying the force and at the other end with a lower tether hook for the attachment to the lower tether anchorage bracket, or any other means in agreement between the manufacturer and the Technical Service and documented in the test report.
In case the vehicle manufacturer does not provide the LTA bracket(s), the loads are transmitted to the LTA after installing a generic lower tether bracket. For anchorages designed to be used for two adjacent (E)CRS positions, or in case of a single LTA, the force shall be $5,000\text{ N} \pm 100\text{ N}$. At the request of the manufacturer the anchorages may be tested at higher loads as long as they fulfil the requirements.
- 6.3.4. The force:
- 6.3.4.1. Shall be applied in a direction determined by the FDRP (force direction reference point), with a tolerance of $\pm 20\text{ mm}$ in all directions given in figure 3 of Annex 6, noting that the FDRP lateral position coincides with the centreline of the ISO/R2 envelope;
- 6.3.4.2. Shall be attained within 30 s, and shall be maintained for a minimum of 0.2 s.
- 6.3.4.3. In case different FDRPs have to be covered, an individual FDRP which is ± 15 degree from the tested one, is considered to meet the requirements.
- 6.3.5. When testing in accordance with paragraphs 6.3.3. and 6.3.4., permanent deformation including partial rupture or breakage of any low tether anchorage or surrounding area shall not constitute failure if the required force is sustained for the specified time and the deformation does not constitute an additional risk to adjacent vehicle safety components in agreement with the Technical Service and Type Approval Authority."

Insert new paragraphs 12. to 12.4., to read:

- "12. TRANSITIONAL PROVISIONS
- 12.1. As from the official date of entry into force of the 01 series of amendments, no Contracting Party applying this Regulation shall refuse to grant or refuse to accept UN type-approval under this Regulation as amended by the 01 series of amendments.
- 12.2. As from 1 September 2026, Contracting Parties applying this Regulation shall not be obliged to accept UN type-approvals to the preceding series of amendments, first issued after 1 September 2026.
- 12.3. As from 1 September 2027, Contracting Parties applying this Regulation shall not be obliged to accept type-approvals issued to the preceding series of amendments to this Regulation.
- 12.4. Notwithstanding paragraphs 12.2 and 12.3, Contracting Parties applying the UN Regulation shall continue to accept, and grant extensions to, UN type-approvals issued according to the preceding series of amendments to the UN Regulation, for vehicle types which are not affected by the changes introduced by the 01 series of amendments."

Annex 1, amend to read:

"Annex 1

Communication

(Maximum format: A4 (210 x 297 mm))

issued by: Name of Administration:



.....
.....
.....

- Concerning:²
- Approval granted
 - Approval extended
 - Approval refused
 - Approval withdrawn
 - Production definitively discontinued

of a vehicle type with regard to ISOFIX anchorages systems, and ISOFIX top tether anchorages, ~~and~~ i-Size seating positions **and lower tether anchorages** if any pursuant to UN Regulation No. 145

Approval No..... Extension No.....

1. Trade name or mark of the power-driven vehicle
 2. Type of vehicle
 3. Manufacturer's name and address
 4. If applicable, name and address of manufacturer's representative
-

¹ Distinguishing number of the country which has granted/extended/refused/withdrawn approval (see approval provisions in the Regulation).

² Strike out what does not apply.

5. Description of seats²
 Utilises additional force according to paragraph 6.2.5.1. of this UN Regulation:
 Yes/No²
 Supplemented force:
 Utilises the exemption per note to paragraph 6.2.5.1. based on safety belt anchorage tests per UN Regulation No. 14 paragraph 6.4.4.: Yes/No²
 UN Regulation No. 14 Approval No.....
6. Utilises ISOFIX exemption permitted by paragraph 5.3.8.: Yes/No²
7. **Vehicle type provided with lower tether anchorages: Yes/No/Optional²**
8. **Vehicle type provided with lower tether brackets: Yes/No/Optional²**
79. Vehicle submitted for approval on:
810. Technical Service responsible for conducting approval tests:

911. Date of report issued by that Service:
1012. Number of report issued by that Service:
1113. Approval granted/extended/refused/withdrawn²
1214. Position of approval mark on vehicle:
1315. Place:
1416. Date:
1517. Signature:
1618. The following documents, filed with the Type Approval Authority which has granted approval and available on request are annexed to this communication:
 Drawings, diagrams and plans of the ISOFIX anchorages systems, of the top tether anchorages **and/or lower tether anchorages including lower tether brackets (if provided by the manufacturer)** if any, vehicle floor contact surface of ~~i-Size seating positions~~ if **any applicable**, and of the vehicle structure;
 Photographs of the ISOFIX anchorages systems, of the top tether **and/or lower tether** if any, vehicle floor contact surface of ~~i-Size seating positions~~ if **any applicable**, and of the vehicle structure;
 Drawings, diagrams and plans of the seats, of their anchorage on the vehicle;
 Photographs of the seats, of their anchorage."

Annex 2, amend to read:

"Annex 2

Arrangements of the Approval Mark

Model A
(see paragraph 4.4. of this Regulation)

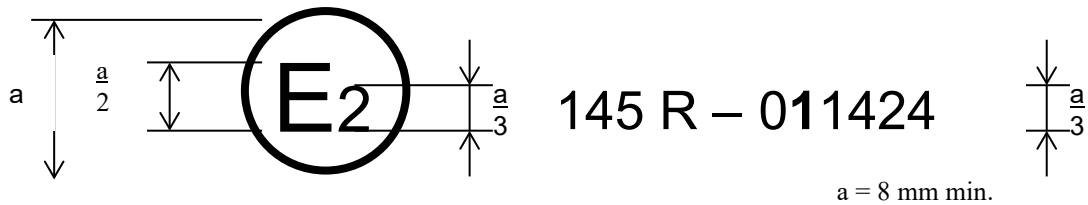

a = 8 mm min.

The above approval mark affixed to a vehicle shows that the vehicle type concerned has, with regard to ISOFIX anchorages systems, and ISOFIX top tether anchorages and i-Size seating positions -belt anchorages, been approved in France (E 2), pursuant to UN Regulation No. 145, under the number 011424. The first two digits of the approval number indicate that the approval was granted in accordance with the requirements of UN Regulation No. 145 01 series of amendments.

Model B
(see paragraph 4.5. of this Regulation)

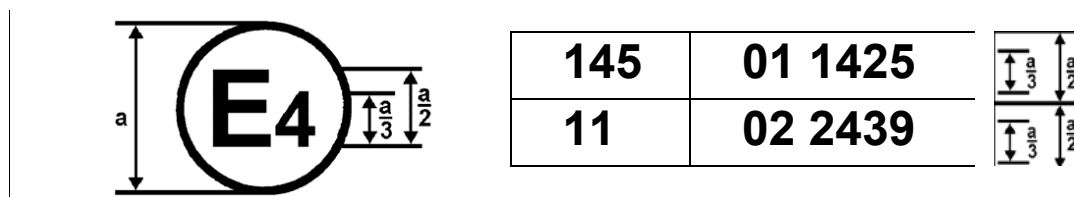

a = 8 mm min.

The above approval mark affixed to a vehicle shows that the vehicle type concerned has been approved in the Netherlands (E 4) pursuant to UN Regulations Nos. 145 and 11*. The approval numbers indicate that on the dates on which these approvals were granted, UN Regulation No. 145 01 series of amendments and UN Regulation No. 11 was in its 02 series of amendments."

* The second number is given merely as an example.

Insert new Annex 6, to read:

"Annex 6

Lower Tether Anchorage Zone and the Position of the Force Direction Reference Point

Figure 1
Lower Tether Anchorage Zone: Side View
 (Dimensions in millimetres)

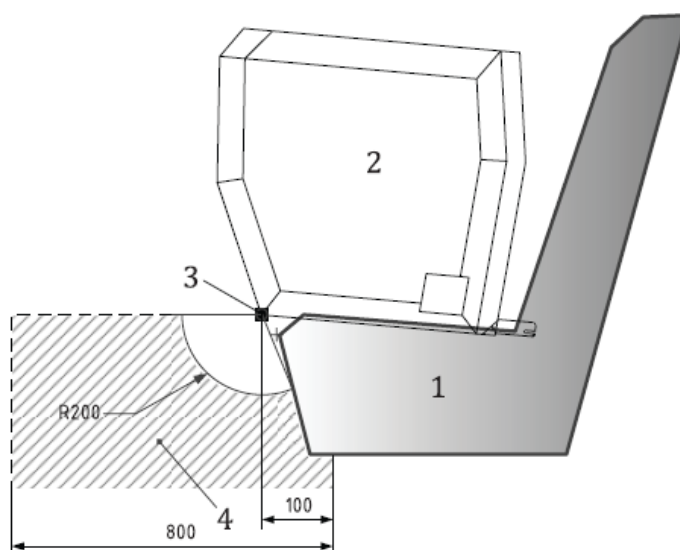

- Key:**
1. vehicle seat illustration.
 2. ISO/R2 envelope installed in related vehicle seating position.
 3. reference point on ISO/R2 envelope for LTA zone measurements.
 4. lower tether anchorage zone in side view, with upper limitation.
 5. where the LTA is integrated with the seat in front, the zone requirements have to be fulfilled independent of the height adjustment settings of the seat in front, **taking the presence of the ISO/R2 envelope into consideration.**

Note: Drawing not to scale.

Figure 2
Lower Tether Anchorage Zone: Top View

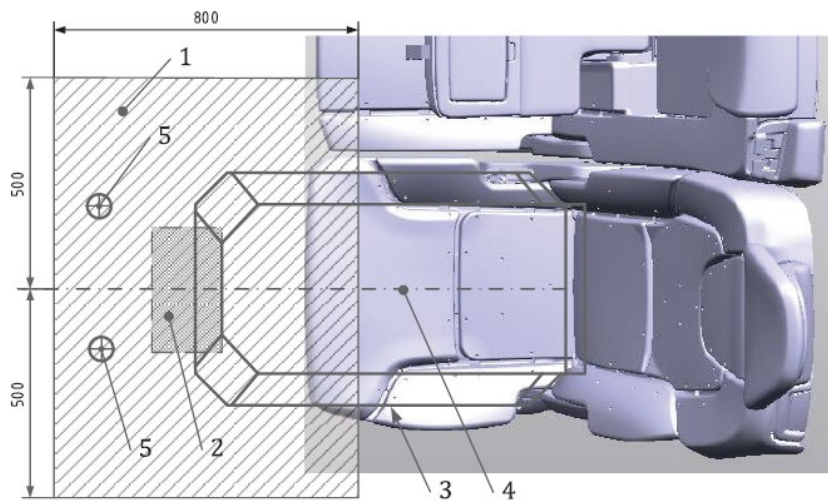

- Key:**
- 1. lower tether anchorage zone, top view.
 - 2. support leg zone (not to be used).
 - 3. ISO/R2 envelope installed in related vehicle seating position.
 - 4. centreline of ISO/R2 and ISOFIX anchorage positions (or the apparent centreline of the seating position in case of non-ISOFIX/i-Size seating positions, according to Annex 6) (contour only shown).
 - 5. lower tether anchorage, example positions

Note: The rearmost surface of the zone is positioned 100 mm rear of a vertical plane through the reference point on the ISO/R2 envelope. See Figures 5 and 6."

Figure 3
Force Direction Reference Point and Direction of Test Force

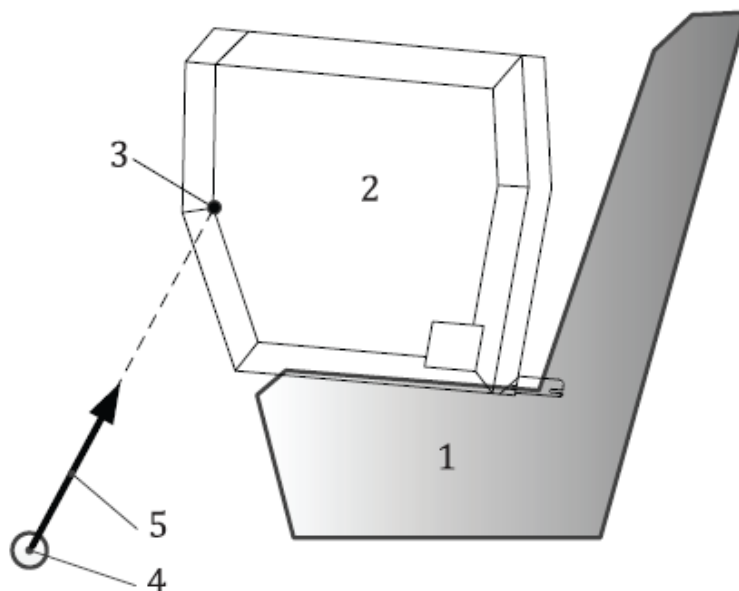

- Key:**
- 1. vehicle seat illustration.
 - 2. ISO/R2 envelope installed in related vehicle seating position.
 - 3. FDRP (force direction reference point).
 - 4. example of actual LTA position in vehicle.
 - 5. test force direction.

Note: The lateral position of FDRP coincides with the centreline of the ISO/R2 envelope"

Insert new Annex 7, to read:

"Annex 7

ISO/R2 Positioning Procedure for non-ISOFIX/i-Size Seating Position

In case of a non-ISOFIX/i-Size vehicle seating position, the following procedure should be applied:

- (a) **Place a cotton cloth on the vehicle seatback and cushion;**
- (b) **Remove the ISOFIX attachments from the child restraint fixture (CRF) or retract them to a position fully inside the backseat line;**
- (c) **Place the CRF on the vehicle seat;**
- (d) **Ensure that the CRF is located with its centreline on the apparent centreline of the seating position, ± 25 mm, with its centreline parallel with the centreline of the vehicle;**
- (e) **Push rearwards on the centre of the front of the CRF with a force of $100\text{ N} \pm 10\text{ N}$, applied parallel to the lower surface, and remove the force;**
- (f) **Push vertically downwards on the centre of the upper surface of the CRF with a force of $100\text{ N} \pm 10\text{ N}$ and remove the force."**

II. Justification

This proposal aims to introduce:

- (a) Definitions and requirements for lower tether anchorages;
- (b) Only provide for a situation that consists of brackets in the vehicle in combination with connectors, similar to ISOFIX top-tether connectors in order to get rid of constructions whereby straps around vehicle seats, straps around seat rails, etc. are used. See GRSP-71-19 for background information;
- (c) The possibility to approve the vehicle floor contact surface for applications of (E)CRS using a support leg in combination with non-ISOFIX/i-Size seating positions, in relation to the strength of the floor and the space for positioning the foot. For this situation and for deformations of the ISOFIX anchorages in general, it shall be verified that the deformation does not constitute an additional risk to adjacent vehicle safety components in agreement with the Technical Service and Type Approval Authority;
- (d) Requirements on lower tether anchorages are based upon ISO 13216-4:2020;
- (e) ISO 13216-4:2020 distinguishes between the zones for front and rear passengers. For the Regulation, it was decided to use the zone definition of the front for both front and rear seating positions, in order to allow the top tether anchorage of the front seat to be used as LTA for the rear. This may only be done where the location of the top tether anchorage is within the zone in all positions of use of the front seat, in order to prevent misuse;
- (f) Strength test on the lower tether anchorages integrated with the seat may be performed on a component level, for the situation that seat belt anchorages are integrated with the seat and have been tested according to UN Regulation No. 14 including the additional inertia load of $20x$ the seat mass (in case of M_1/N_1);
- (g) Since there are vehicles on the market already equipped with LTAs that do not meet the requirements of the Regulation or approved as such, there is a need to introduce transitional provisions and therefore a new series of amendments.

