



Economic and Social Council

Distr.: General
30 March 2023

Original: English

Economic Commission for Europe

Inland Transport Committee

World Forum for Harmonization of Vehicle Regulations

190th session

Geneva, 20-22 June 2023

Item 4.6.6 of the provisional agenda

1958 Agreement:

**Consideration of draft amendments to existing UN Regulations
submitted by GRSP**

Proposal for Supplement 9 to the 03 series of amendments to UN Regulation No. 129 (Enhanced Child Restraint systems)

Submitted by the Working Party on Passive Safety *

The text reproduced below was adopted by the Working Party on Passive Safety (GRSP) at its seventy-second session (ECE/TRANS/WP.29/GRSP/72, paras. 26 – 29). It is based on GRSP-72-01 and GRSP-72-16, as reproduced in annex V to the report, ECE/TRANS/WP.29/GRSP/2021/26 as amended by annex V to the report and ECE/TRANS/WP.29/GRSP/2022/25 not amended. It is submitted to the World Forum for Harmonization of Vehicle Regulations (WP.29) and to the Administrative Committee (AC.1) for consideration at their June 2023 sessions.

* In accordance with the programme of work of the Inland Transport Committee for 2023 as outlined in proposed programme budget for 2023 (A/77/6 (Sect. 20), table 20.6), the World Forum will develop, harmonize and update UN Regulations in order to enhance the performance of vehicles. The present document is submitted in conformity with that mandate.



Paragraph 6.3.1.1., amend to read:

"6.3.1.1. The Enhanced Child Restraint System ... of EN 71-3:2019+A1:2021, ..."

Paragraph 6.3.1.2., amend to read:

"6.3.1.2. The flammability of Enhanced Child Restraint Systems submitted for approval shall be assessed by one of the following methods:

... of EN 71-2:2021 with a maximum rate ..."

Paragraph 6.3.5.1., amend to read:

"6.3.5.1. Support-leg and support-leg foot geometrical requirements

The support leg, including its attachment to the Enhanced child restraint systems and the support-leg foot shall lie completely within the support leg dimension assessment volume (see also figures 1 and 2 of annex 19 of this Regulation), which is defined as follows:

- (a) In width by two planes parallel to the X'-Z' plane separated by 200 mm, and centred around the origin; and
- (b) In length by two planes parallel to the Z'-Y' plane and positioned at distances of 585 mm and 695 mm forward of the origin along the X' axis; and
- (c) In height by a plane parallel to the X'-Y' plane, positioned at a distance of 185 mm above the origin and measured perpendicular to the X'-Y' plane. Rigid, non-adjustable parts of the support leg shall not extend beyond a plane parallel to the X'-Y' plane, positioned at a distance of 285 mm below the origin for forward-facing ECRS or 185 mm above the origin for rear-facing ECRS and in each case measured perpendicular to the X'-Y' plane.

The support-leg may protrude the support-leg dimension assessment volume, providing it remains within the volume of the relevant CRF."

Paragraph 6.6.4.1.1., amend to read:

"6.6.4.1.1. Forward-facing Enhanced Child Restraint Systems

Integral Enhanced Child Restraints: No part of the head of the dummy shall pass beyond the planes BA, DA and DE as defined in Figure 4 below:

- (a) The value in relation to the BA plane is 500 mm; and
- (b) The value in relation to the DA plane is 800 mm, except when testing with the Q3 or Q6 dummy where the value is 840 mm; and
- (c) However, the head of the dummy may pass beyond the DE plane, if the head pad or the backrest part of the child restraint structure, which is behind the head of the dummy, at the point the head, passes the DE plane; and
- (d) In case of dummy contact with a rigid part of the test bench in the rebound phase, the head acceleration criterion during that contact shall not be considered.

This shall be judged up to 300 ms or at the moment when the dummy comes to a definitive standstill, whatever occurs first.

Non-integral booster seat: No part of the head of the dummy shall pass beyond the planes BA and DA as defined in Figure 4 below.

This shall be judged up to 300 ms or the moment that the dummy has come to a definitive standstill, whatever occurs first.

When testing with the Q3 or Q6 dummy, the following applies:

The value in relation to the DA plane is 840 mm.

When testing the Q10 dummy, the following apply:

- (a) The value in relation to the BA plane is 550 mm; and
- (b) The value in relation to the DA plane is 840 mm; and
- (c) The rebound phase is not considered for the assessment of the plane DA.

Non-integral booster cushion: No part of the head of the dummy shall pass beyond the planes BA and DA as defined in Figure 4 below.

This shall be judged up to 300 ms or the moment that the dummy has come to a definitive standstill, whatever occurs first.

When testing with the Q6 dummy, the following applies:

The value in relation to the DA plane is 840 mm.

When testing using Q10 dummy the following apply:

- (a) The value in relation to the BA plane is 550 mm; and
- (b) The value in relation to the DA plane is 840 mm; and
- (c) The rebound phase is not considered for the assessment of the plane DA; and
- (d) In case of dummy contact with a rigid part of the test bench in the rebound phase, the head acceleration criterion during that contact shall not be considered.

6.6.4.4.1.1.1. Where a test is conducted in accordance with paragraph 6.6.4.1.6.1.1. or paragraph 6.6.4.1.6.1.2. or paragraph 6.6.4.1.8.2. above, a tolerance of +10 per cent shall be applicable to the head excursion value distance between the Cr point and plane AB.

Figure 4
Arrangement for Testing a Forward-Facing Device

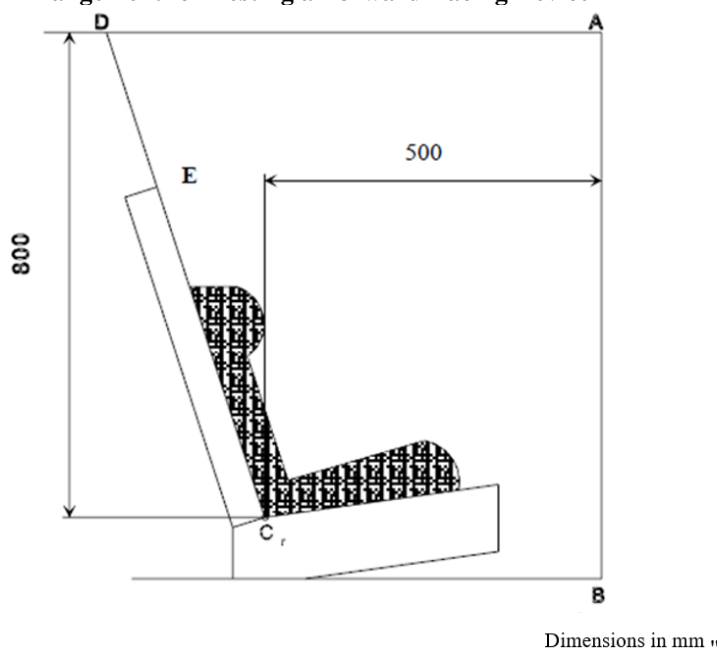

Paragraph 7.1.3.6.4., amend to read:

"7.1.3.6.4. The test specified in paragraph 6.6.4.1.6.1.1. above is a requirement only for the largest dummy for which the child restraint is designed."

Paragraph 9.2., amend to read:

"9.2. Qualifying the production of Enhanced Child Restraint Systems.

The production of each new approved type of Enhanced Child Restraint System shall be subjected to production qualification tests. Where the type approval consists of different modules, product qualification tests will be conducted with each module of the ECRS.

Additional qualifications of production may be prescribed following paragraph 11.4.

..."

Annex 19., Figure 1, amend to read:

"Figure 1

Side view of the support leg dimension assessment volume

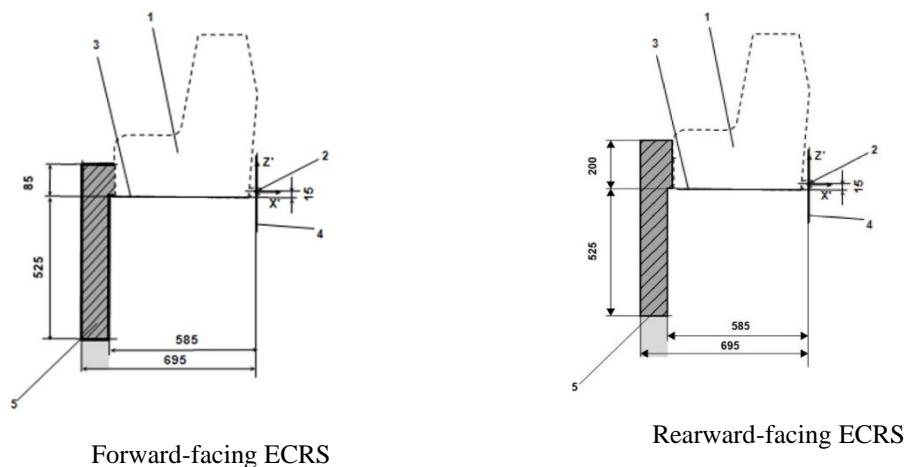

Key:

1. Enhanced Child Restraint Fixture (ECRF).
2. ISOFIX low anchorages bar.
3. Plane formed by the bottom surface of the ECRF, which is parallel to and 15 mm below the X'-Y' plane of the coordinate system.
4. Z'-Y' plane of the coordinate system.
5. Upper part of the support-leg dimension assessment volume, which shows the dimensional limitations in X' and Y' direction, the upper height limit in Z' direction, as well as the lower height limitation in Z' direction for rigid, not in Z' direction adjustable support leg components.

Note:

1. Drawing not to scale."

Annex 19, Figure 2, amend to read:

"Figure 2
3D view of the support leg dimension assessment volume

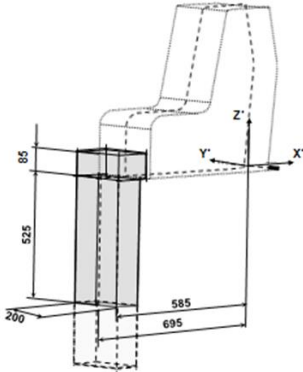

Forward-facing ECRS

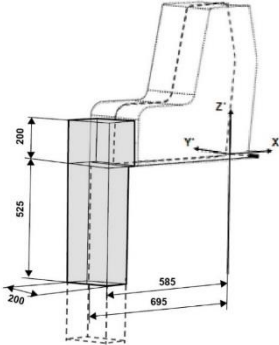

Rearward-facing ECRS

Note: Drawing not to scale."