



Economic and Social Council

Distr.: General
29 March 2023

Original: English

Economic Commission for Europe

Inland Transport Committee

World Forum for Harmonization of Vehicle Regulations

190th session

Geneva, 20-22 June 2023

Item 4.6.1 of the provisional agenda

1958 Agreement:

**Consideration of draft amendments to existing UN Regulations
submitted by GRSP**

Proposal for Supplement 4 to the 08 series of amendment to UN Regulation No. 16 (Safety-belts)

Submitted by the Working Party on Passive Safety *

The text reproduced below was adopted by the Working Party on Passive Safety (GRSP) at its seventy-second session (ECE/TRANS/WP.29/GRSP/72, paras. 11 and 13). It is based on ECE/TRANS/WP.29/GRSP/2021/20 as amended by annex III to the report and ECE/TRANS/WP.29/GRSP/2021/25 not amended. It is submitted to the World Forum for Harmonization of Vehicle Regulations (WP.29) and to the Administrative Committee (AC.1) for consideration at their June 2023 sessions.

* In accordance with the programme of work of the Inland Transport Committee for 2023 as outlined in proposed programme budget for 2023 (A/77/6 (Sect. 20), table 20.6), the World Forum will develop, harmonize and update UN Regulations in order to enhance the performance of vehicles. The present document is submitted in conformity with that mandate.



Annex 17, Appendix 2, Figure 9, amend to read:

"Figure 9

Side view of the i-Size support leg installation assessment volume for assessing compatibility of the i-Size seating positions with support legs of i-Size child restraint systems

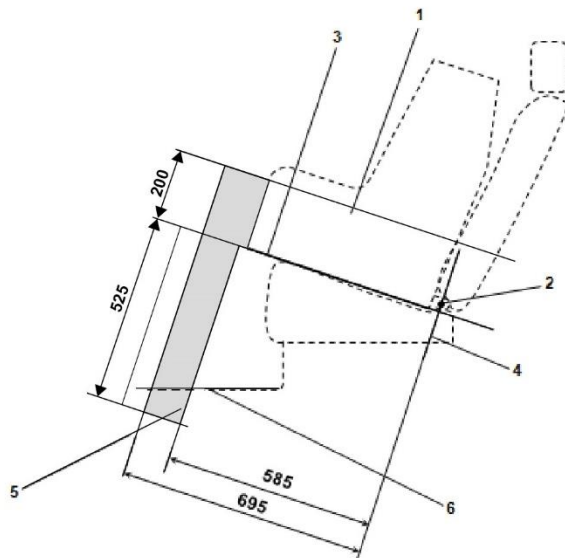

Key:

1. Child Restraint Fixture (CRF).
2. ISOFIX low anchorages bar.
3. Plane formed by the bottom surface of the CRF when installed in the designated seating position.
4. Plane passing through the lower anchorage bar and oriented perpendicular to the median longitudinal plane of the CRF and perpendicular to the plane formed by the bottom surface of the CRF when installed in the designated seating position.
5. i-Size support leg installation assessment volume representing the geometrical boundaries for an i-Size ISOFIX child restraint system support leg.
6. Vehicle floor.

Note: Drawing not to scale."

Annex 17, Appendix 2, Figure 10, amend to read:

"Figure 10
3D view of the i-Size support leg installation assessment volume for assessing compatibility of the i-Size seating positions with support legs of i-Size child restraint systems

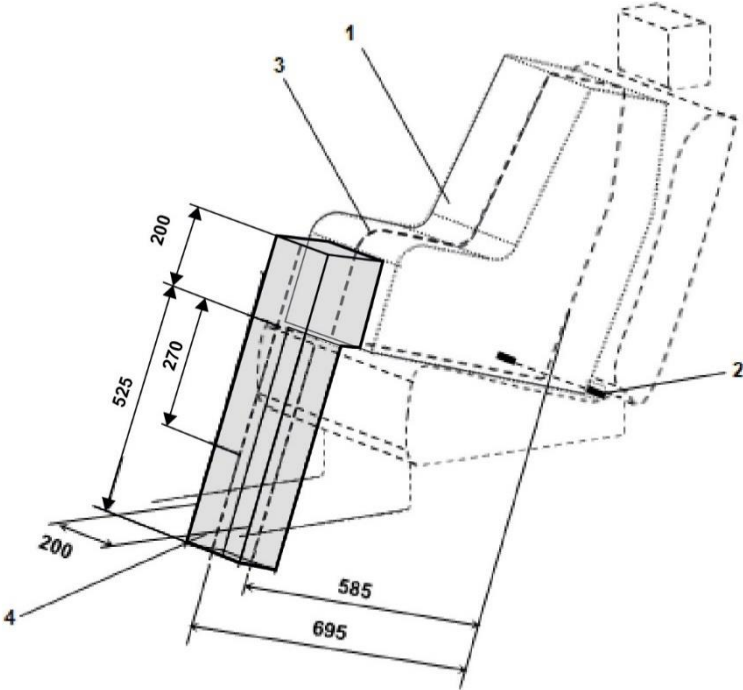

(all dimensions in millimetres)

- Key:
- 1. Child Restraint Fixture (CRF).
 - 2. ISOFIX low anchorages bar.
 - 3. Median longitudinal plane of the CRF.
 - 4. i-Size support leg installation assessment volume.
- Note: Drawing not to scale."

Annex 17 – Appendix 5, Figure 2, amend to read:

"Figure 2

ISO/B2: Envelope dimensions for booster seat, reduced width 440 mm - without ISOFIX, or with connectors removed or stowed within the body of the fixture (behind line E, as defined by detail B)

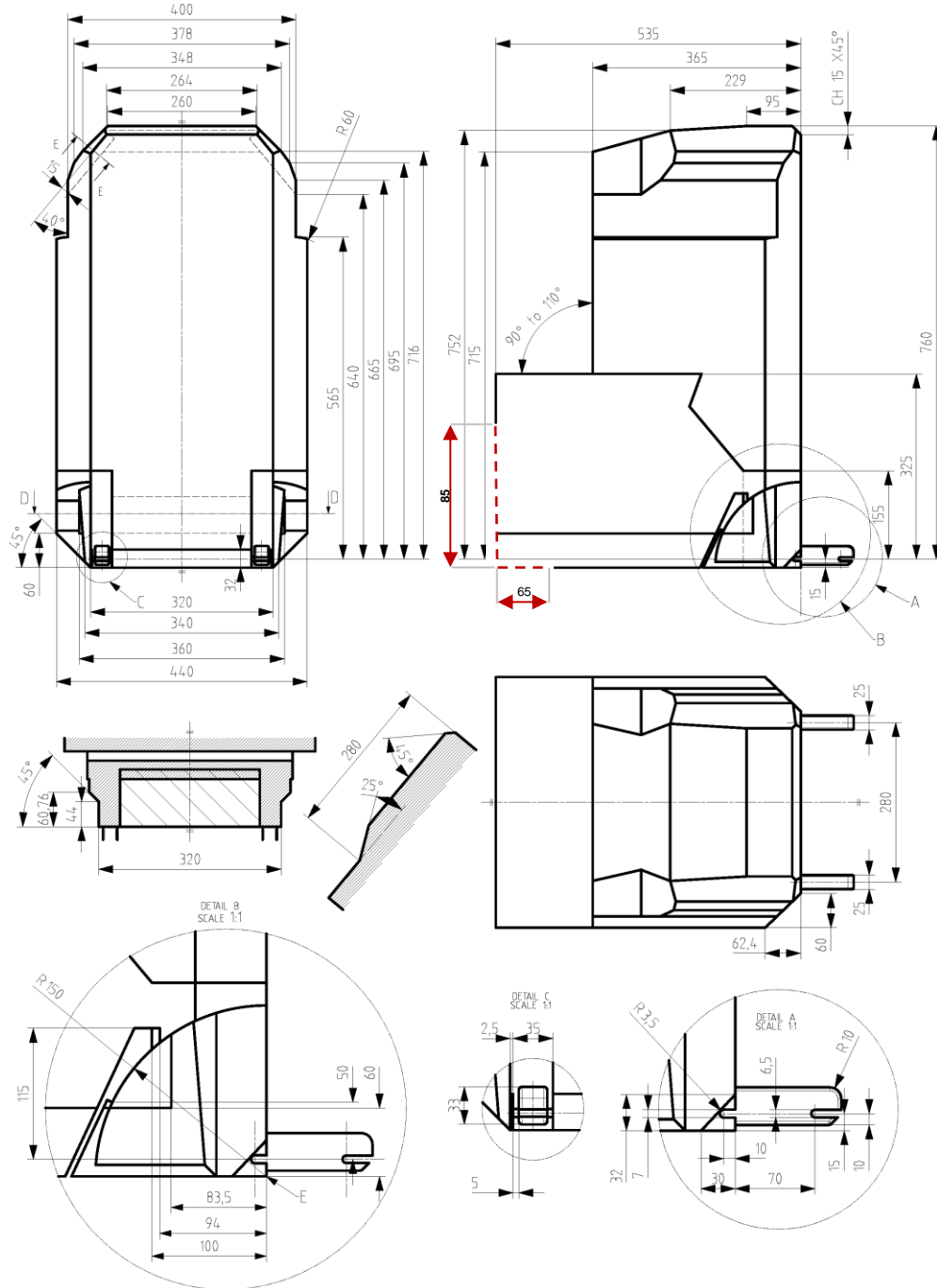

(all dimensions in millimetres)

Key

1. E is the Reference axle of rotation of the backrest (90° to 110°) and reference line for retraction/stowing of ISOFIX
2. Dashed lines mark the area where an anti-rotation device, or similar is allowed to protrude"

Annex 17 – Appendix 5, Figure 3, amend to read:

"Figure 3
ISO/B3 - Envelope dimensions for booster seat, full width 520 mm - without ISOFIX, or with connectors removed or stowed within the body of the fixture (behind line E, as defined by detail B)

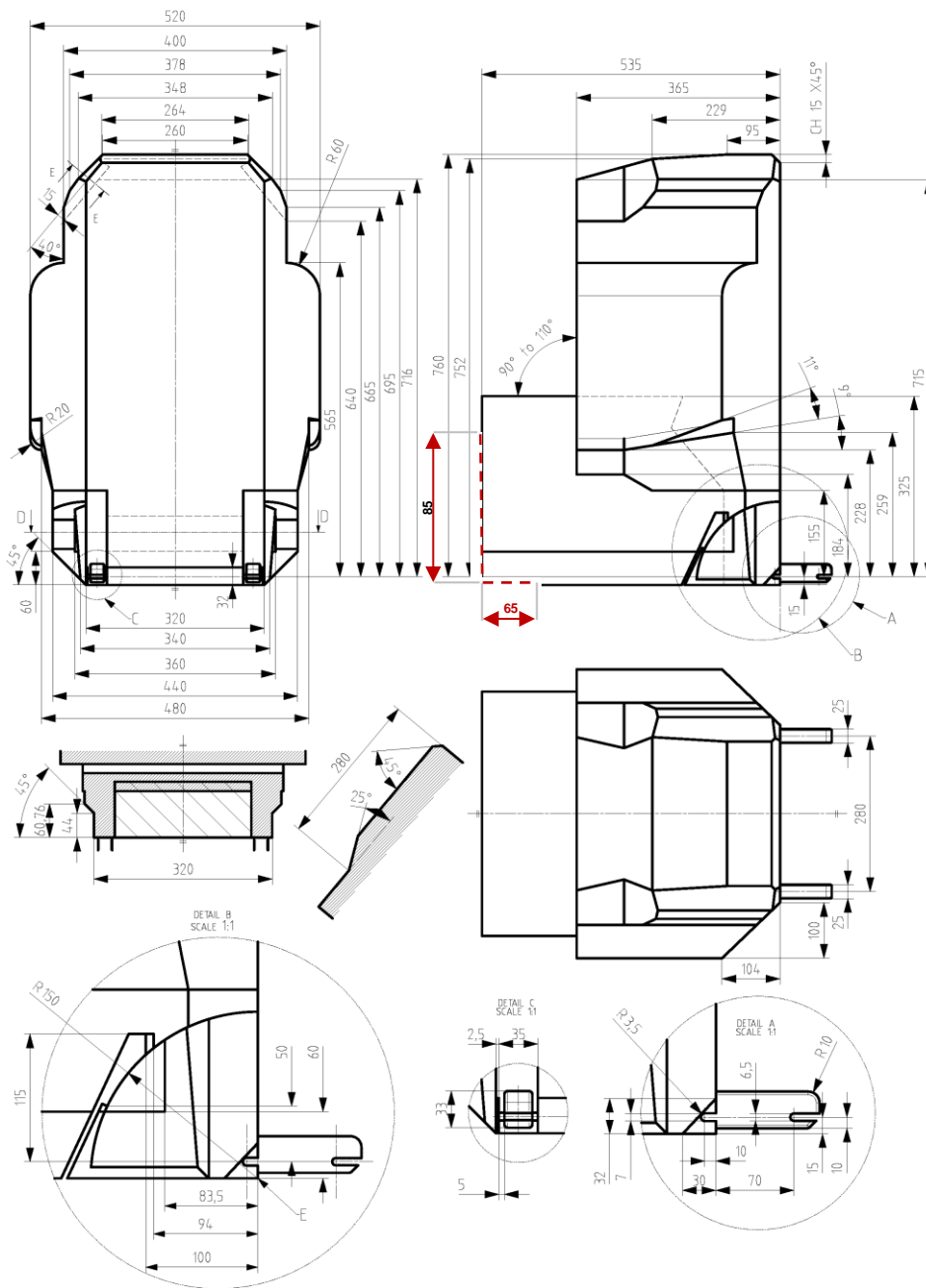

(all dimensions in millimetres)

Key

1. E is the reference axle of rotation of the backrest (90° to 110°) and reference line for retraction/stowing of ISOFIX
2. Dashed lines mark the area where an anti-rotation device, or similar is allowed to protrude"