

Status Report of the Informal Working Group on Safer Transport of Children in Buses and Coaches (IWG-STCBC)

CHAIR: MARTA ANGLÈS , SPAIN

SECRETARY: COSTANDINOS VISVIKIS, CLEPA

Informal Working Group

Last meeting

Next meeting

⊕ 15th IWG-STCBC meeting

Date: 31st January 2023

Location: Online meeting

Timeline

Plan and Schedule

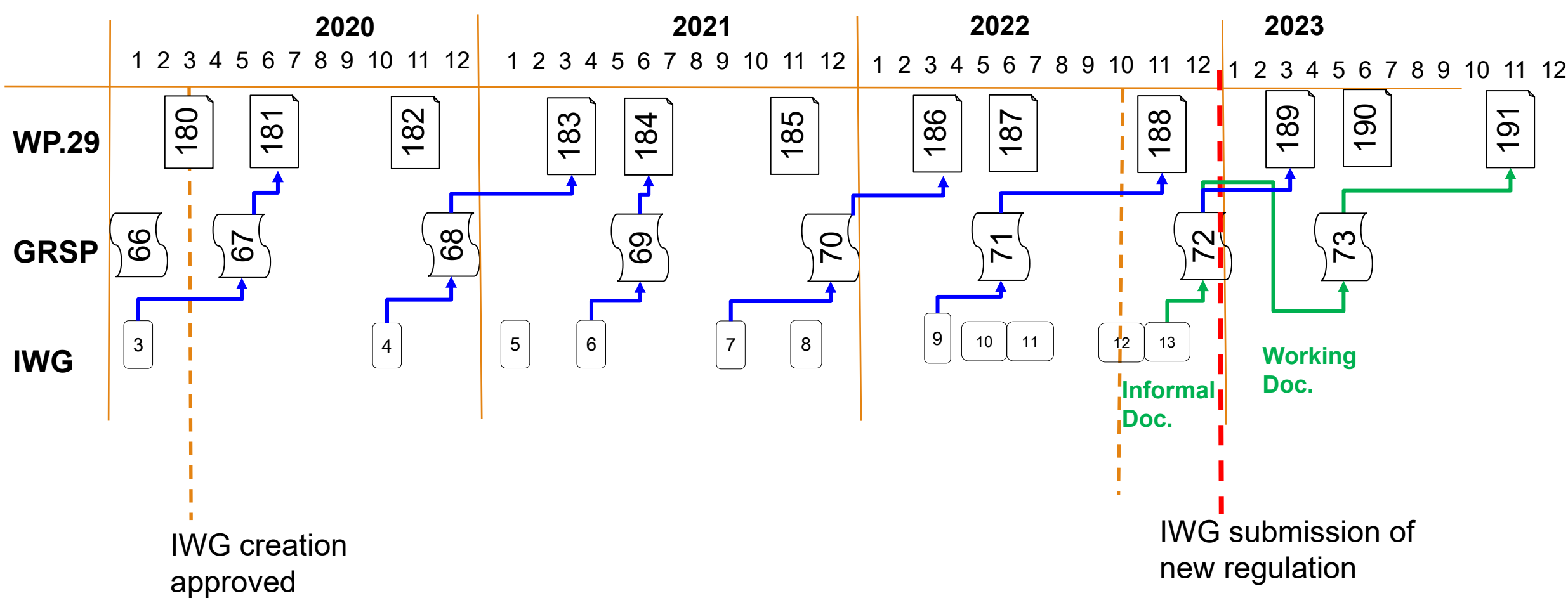

Summary of the new UN Regulation

Summary	
Time line	GRSP- December 2022 WP.29 - 2023
Objective	No ejection of the children. Good retention in the seat
Phase 1	a: CRS approved according to R-129 with 3-point belt and or ISOFIX b: Built in systems
Phase 2	CRS in combination with 2-point belts

UN Regulation

- ⊕ Working document submitted to the GRSP 73th session:

(Spain) Proposal for a new UN Regulation concerning the Safer Transport of Children in Buses and Coaches.

ECE-TRANS-WP.29-GRSP-2023-XX

Next Steps

- ⊕ To be considered in the GRSG:
 - ⊕ R107: Bus seats equipped with built in CRS to be approved according the UN Regulation XXX
 - ⊕ Emergency windows

- ⊕ To be considered in the GRSP:
 - ⊕ Face to face Built in CRS and adult seating position:
 - ⊕ UN R16: the vehicle seat behind the CRS shall have a 3-point belt.
Working document ECE-TRANS-WP.29-GRSP-2023-XX

Next Steps

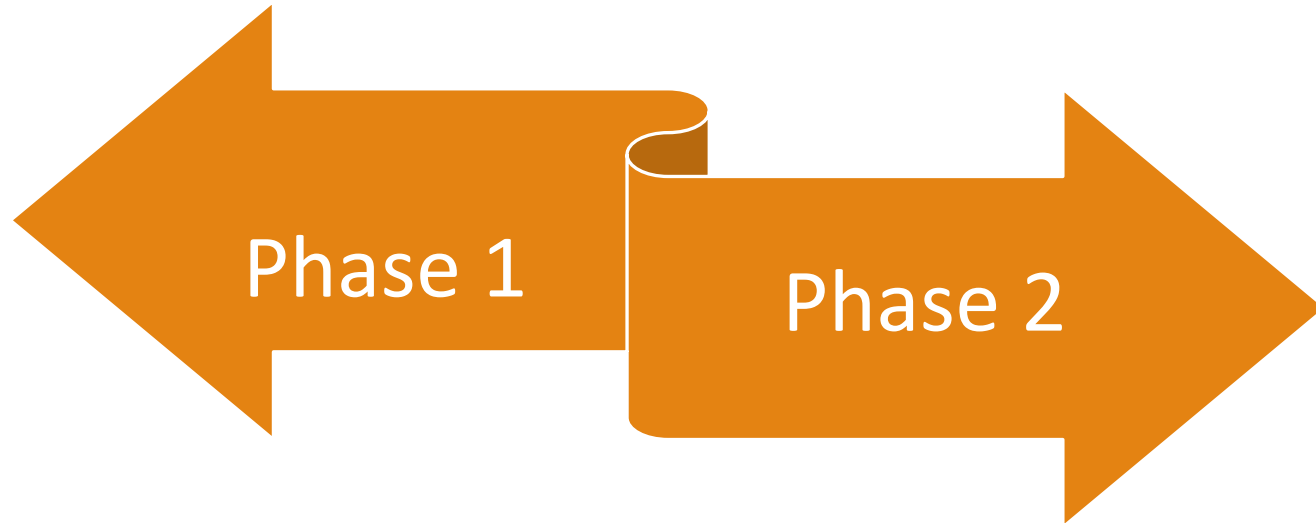

Child Restraint Systems in combination with 2-point belts.

- 90 % of the bus fleet equipped with 2-point belt.
- Objective is the retention of the children in rollovers.
- Solution for existing buses and CRS.
- 1 solution is now available with, built-in systems, 3-point belts or ISOFIX.

Thank you for your attention
