



# Economic and Social Council

Distr.: General  
28 October 2022

Original: English

Informal document GRPE-87-40  
8<sup>th</sup> GRPE, 10-13 January 2023  
Agenda item 7

This is a clean version including all changes  
to GRPE/2023/4

---

## Economic Commission for Europe

### Inland Transport Committee

### World Forum for Harmonization of Vehicle Regulations

#### Working Party on Pollution and Energy

#### Eighty-seventh session

Geneva, 10-13 January 2023

Item 7. of the provisional agenda

#### Particle Measurement Programme (PMP)

## **Proposal for a new UN GTR on Laboratory Measurement of Brake Emissions for Light-Duty Vehicles**

### **Submitted by the Informal Working Group on Particulate Measurement Programme \***

The text reproduced below was prepared by the Informal Working Group (IWG) on Particulate Measurement Programme (PMP) following the authorization given by WP.29/AC.3 in March 2022 to develop this UN GTR (ECE/TRANS/WP.29/AC.3/59). It is a proposal for a new UN GTR on Laboratory Measurement of Brake Emissions for Light-Duty Vehicles. A first draft of this proposal was made available as an informal document by the IWG on PMP at the 86th session of GRPE (see informal document GRPE-86-46).

---

\* In accordance with the programme of work of the Inland Transport Committee for 2023 as outlined in proposed programme budget for 2023 (A/77/6 (Sect. 20), table 20.6), the World Forum will develop, harmonize and update UN Regulations in order to enhance the performance of vehicles. The present document is submitted in conformity with that mandate.

## Contents

	<i>Page</i> *
I. Statement of technical rationale and justification.....	3
A. Introduction .....	3
B. Procedural Background and Future Development.....	4
C. Background on the Technical Work of the PMP Group.....	6
II. Text of the GTR .....	8
1. Purpose .....	8
2. Scope and Application .....	8
3. Definitions .....	8
4. Abbreviations and Symbols.....	17
5. General Requirements .....	22
6. General Overview .....	23
7. Test System Requirements .....	25
8. Test Preparation Requirements .....	42
9. WLTP-Brake Cycle.....	52
10. Cooling Airflow Adjustment.....	58
11. Bedding Section .....	63
12. Emissions Measurements Section .....	65
13. Test Output.....	85
14. Calibration Requirements and Ongoing Quality Controls.....	117
Annexes	
A. WLTP-Brake Cycle Events .....	124
B. WLTP-Brake Cycle Brake Events.....	138

---

\* Page numbers to be corrected at a later stage.

## I. Statement of technical rationale and justification

### A. Introduction

1. Over recent years there has been a sharp increase in international interest to characterise non-exhaust emissions of particles from road transport. Until recently, exhaust sources dominated road transport emissions, and all regulatory efforts have been aiming at their reduction. As exhaust emissions were reduced due to increasingly stringent regulations, the relative contribution of non-exhaust emissions to overall ambient concentrations of particulate matter increased.

2. Most manufacturers produce vehicles for a global clientele, or at least for several regions. Since manufacturers tend to cater to the preferences, needs, and lifestyles of specific geographic regions, vehicle designs will vary worldwide. As compliance with different emission standards in each region can create burdens from an administrative and vehicle design point of view, vehicle manufacturers tend to have a strong interest in harmonising brake emission test procedures and performance requirements on a global scale. Global harmonisation is also of interest to regulators as it offers more efficient development and adaptation to technical progress, potential collaborations with market surveillance, and facilitates the exchange of information between regulatory authorities.

3. In this context, stakeholders launched the work for this United Nations Global Technical Regulation (UN GTR) on Worldwide harmonised Light vehicle Test Procedures (WLTP) for particle emissions from brake wear. This UN GTR aims to harmonise test procedures for emissions from Light-Duty Vehicles (LDV) to the extent possible. Laboratory test procedures need to represent real driving conditions as much as possible and to enable a direct comparison between the performance of vehicles during certification procedures and in real life. However, this aspect puts some limitations on the level of harmonisation to be achieved. Furthermore, different countries will show varying levels of development, population densities, and costs associated with braking system technology. Consequently, the regulatory stringency of legislation is expected to vary from region to region for the foreseeable future. Therefore, the definition of emission limit values is not part of this UN GTR. Nevertheless, the long-term goal is still to define globally harmonized performance requirements and emission limits in forthcoming amendments to this GTR.

4. UN GTRs are intended to be implemented into regional legislation by as many Contracting Parties as possible. The selection of vehicle categories to be covered by the scope of regional legislation represents a challenge as it depends on regional conditions that cannot be anticipated. However, according to the provisions of the 1998 UN ECE agreement, a UN GTR being implemented by a Contracting Party must apply to all vehicles, conditions, and equipment falling under its formal scope. Therefore, care must be taken in developing the scope of the UN GTR, as an unduly large formal scope may prevent or hamper its implementation into regional legislation. For this reason, the formal scope of this UN GTR is limited to Light-Duty vehicles up to 3500 kg. This limitation does not, however, indicate that the scope of this UN GTR should not be applied to a larger group of vehicle categories when implemented into regional legislation. Indeed, Contracting Parties are encouraged to do so if this is feasible and appropriate from a technical, economical, and administrative point of view.

5. A harmonised approach for measuring brake particle emissions would allow manufacturers to better understand the behaviour of different brake systems, reduce inconsistencies in results and; therefore, compare them more efficiently, and develop strategies to decrease brake emissions.

6. This version of the UN GTR does not contain test requirements specific to other types of vehicles e.g. off-road, special purpose, and heavy-duty vehicles. Thus, these vehicles are not included in the scope of this UN GTR. However, Contracting Parties may apply the provisions within this UN GTR to such vehicles to the extent possible from a technical point of view, and complement them with additional provisions in regional legislation e.g. brake emission testing with different types of friction materials or mating parts.

## B. Procedural background and future development

7. In 2013, following the submission of informal documents by the Russian Federation, UNECE WP.29 agreed with the GRPE decision to task the Informal Working Group on Particle Measurement Programme (IWG on PMP) to investigate the issues concerning the emissions of non-exhaust emissions of particles from road transport. The main objective of the IWG on PMP was to investigate whether there is a need to extend particle measurement procedures to additional sources such as brake, tyre, and road wear.

8. The IWG on PMP identified brake and tyre wear as the most relevant sources of non-exhaust emissions of particles from road transport and selected them as the main topics for future investigation (Informal document GRPE-69-23). With regards to brake wear emissions, the primary task of the IWG on PMP has been to define a set of “normal” or “typical” driving conditions, investigate the suitability of existing driving cycles for studying brake particle emissions, and develop a novel test cycle reproducing the driving and braking activity of Light-Duty vehicles in real-world conditions. Other main tasks included the broadening of the IWG on PMP to include non-exhaust experts, the development of guidelines and best practices for sampling and measuring brake wear particles, and the establishment of minimum requirements to report test results.

9. Following the approval by AC.3 of the first mandate of the IWG on PMP regarding non-exhaust emissions in June 2013, the IWG on PMP aimed to accomplish the following objectives, which were completed by June 2016:

(a) Conduct a literature survey summarising the current knowledge on the physical/chemical nature, mass, number, and size distribution of non-exhaust particle emissions (JRC 89231 – EUR 26648);

(b) Identify and report the main knowledge gaps and the needs for future research. These findings were included in a report submitted to the 69th GRPE session (Informal Document GRPE-69-23);

(c) Establish a group of experts in the field of non-exhaust emissions, sharing information and ongoing research on topics related to non-exhaust emissions;

(d) Analyse the WLTP database to define normal and extreme driving conditions, and gather information on existing methodologies for sampling and measuring non-exhaust emissions;

(e) Consider the most suitable testing approach for brake emissions, and define the pros and cons of different available options (brake test rig, full vehicle chassis dyno, vehicle on-road, etc.).

10. In the context of point (e), the IWG on PMP extensively discussed several options for a standardised method to sample and characterise brake wear particles, and eventually selected an approach based on a fully-enclosed brake dynamometer. This method allows the sampling of particles from brake wear without interferences from other sources and minimises particle losses over the entire sampling and measurement line. Furthermore, brake dynamometers offer a flexible platform to test different brakes under various driving conditions and vehicle loads. The laboratory setup needs to enable repeatable and reproducible measurements at least for a defined set of core parameters. An appropriate installation of the laboratory setup will then allow the end-user to select additional values worth measuring, within the capabilities of the system.

11. A second mandate for the IWG on PMP with specific reference to non-exhaust emissions was approved in June 2016 by AC.3. The IWG on PMP was mandated to develop a commonly accepted test procedure for sampling and assessing brake wear particles both in terms of mass and number. The methodology would aim to provide the necessary tool to support future studies on brake emissions that can be easily compared. During the reporting period of the mandate (2016-2019) the following items were addressed:

(a) Development and validation of a novel test cycle appropriate for the investigation of brake wear particles;

(b) Investigation and selection of the appropriate methodologies for particle generation and sampling;

(c) Investigation and selection of the appropriate instrumentation for the measurement and characterisation of brake wear particles.

12. After completing a thorough analysis regarding the suitability of existing brake cycles, the IWG on PMP decided to proceed with the development of a novel test cycle appropriate for the investigation of brake wear particles. Therefore, the IWG on PMP decided to create a dedicated Task Force (TF1) to accelerate the development of a test cycle in October 2016. In September 2017, the IWG on PMP decided to create a dedicated Task Force (TF2) to investigate and select the appropriate methodologies and instrumentation for the measurement of brake wear particles. TF2 initiated its activities in October 2017.

13. During the reporting period (2016-2019), the IWG on PMP aimed to accomplish the following objectives:

(a) Selection of the brake test rig methodology for the generation and sampling of brake wear particles;

(b) Agreement on the method's target measurement parameters. TF2 agreed unanimously that both PM (PM<sub>10</sub> and PM<sub>2.5</sub>) and PN ( $\geq 10$  nm) emissions shall be addressed;

(c) Development and publication of the WLTP-Brake cycle. The cycle is based on real-world data extracted from the WLTP database and is considered representative of real-world applications;

(d) Validation of the WLTP-Brake cycle through an interlaboratory accuracy study exercise which was completed in 8 different laboratories in Europe and the United States;

(e) A thorough analysis of the existing methods and setups for the sampling and measurement of brake particle emissions. Agreement on the need of defining a set of minimum specifications and requirements for sampling and measurement of brake particle emissions.

14. The mandate for the IWG on PMP regarding non-exhaust emissions was further extended in June 2019 by AC.3. The revised mandate included an additional item compared to 2016, which foresaw the validation of the proposed methodology for the measurement and characterisation of brake wear particles. During the reporting period (2019-2020), the IWG on PMP aimed to accomplish the following objectives:

(a) Update the GRPE of the work of the IWG on PMP (TF1) on the development of the novel WLTP-Brake cycle and its application in the measurement and characterisation of brake emissions at brake dynamometer level;

(b) A first discussion on how to address future technologies took place at the IWG on PMP level following the request of several GRPE stakeholders.

15. The mandate for the IWG on PMP regarding non-exhaust emissions was further extended in June 2020 by AC.3. Following the discussion at the IWG on PMP level, the revised mandate included the extension of the proposed methodology to future technologies. In June 2020, several GRPE Contracting Parties urged the IWG on PMP to start considering a possible use of the proposed method as a regulatory tool. Therefore, the IWG on PMP was requested to start looking at the necessary changes and adaptations to extend the method to all existing technologies and other vehicle categories.

16. Stakeholders and Contracting Parties discussed the possible approaches to regulate brake particle emissions in a workshop in January 2021. The main topics discussed during the workshop include:

(a) The ideal scheme for regulating brake emissions from conventional ICE Light-Duty vehicles;

(b) How to handle non-conventional Light-Duty vehicles (i.e. HEVs, PEVs) in a possible future regulatory approach;

(c) Heavy-Duty vehicle brake emissions and possible approaches.

17. As a follow-up of the workshop, the interested Contracting Parties and the IWG on PMP recommended that a UN GTR on brake PM and PN emissions from all types of Light-Duty vehicle brake systems is developed under a new mandate. Therefore, the representatives of the European Union, the UK and Japan sought and obtained authorisation from AC.3 to develop a new UN GTR on brake PM and PN emissions from all types of LDVs brake systems.

### **C. Background on the technical work of the PMP group**

18. The IWG on PMP decided to create a dedicated Task Force (TF1) to accelerate the development of a test cycle in October 2016 (PMP 41<sup>st</sup> Session). The TF1 main tasks included the definition of testing parameters such as dynamometer climatic controls, the definition of the temperature measurement method, the development of a methodology for adjusting the cooling airflow based on real-world vehicle data, the support for the development of a novel test cycle, and the validation of the novel test cycle through an Inter-Laboratory Study. The novel WLTP-Brake cycle was developed in July 2018 and presented to the IWG on PMP in November 2018 (PMP 48<sup>th</sup> Session). The WLTP-Brake cycle was validated through an Inter-Laboratory Study 1 (ILS-1) with the participation of eight testing facilities. The results of the validation were presented to the IWG on PMP in April 2019 (PMP 50<sup>th</sup> Session). TF1 concluded its activities in October 2019 having completed 30 meetings.

19. The IWG on PMP decided to create a dedicated Task Force (TF2) to investigate and select the appropriate methodologies and instrumentation for sampling and measurement of brake wear particles (PMP 43<sup>rd</sup> Session). TF2 main tasks included the definition of the appropriate test setup for sampling and measuring brake particle emissions, the definition of the appropriate instrumentation for sampling and measuring brake particulate matter emissions, the definition of the appropriate instrumentation for sampling and measuring brake particle number emissions, and the definition of the appropriate protocol for sampling and measuring brake particle emissions. The TF2 submitted its recommendations for the minimum specifications for testing brake particle emissions to the IWG on PMP in July 2021 (PMP Web Conference 15.07.2021). TF2 recommendations were applied to the Inter-Laboratory Study 2 (ILS-2) to test their suitability and improve the proposed protocol. TF2 resumed its activities after the completion of the ILS-2 to finalise the protocol and prepare a proposal for the draft UN GTR to the IWG on PMP. The proposal was presented to the IWG on PMP in June 2022 (PMP Web Conference 15.06.2022). TF2 concluded its activities in June 2022 having completed 45 meetings.

20. The IWG on PMP decided to create a dedicated Task Force (TF3) to organise and execute the ILS-2 in March 2021 (PMP Web Conference 24.03.2021). The TF3 main tasks included the organisation and execution of the ILS-2, the verification of the feasibility and applicability of the defined specifications for sampling and measuring brake particle emissions, the examination of the repeatability and reproducibility of PM and PN emission measurements with the application of the defined specifications, and the preparation of recommendations to the TF2 on further improving and/or extending the set of the defined specifications. The ILS-2 was launched in September 2021 and finalised in January 2022. The results of the ILS-2 were presented to the IWG on PMP in March 2022 (PMP Web Conference 29.03.2022). TF3 concluded its activities in April 2022 having completed 6 meetings.

21. The IWG on PMP created a dedicated Task Force (TF4) to investigate and select the appropriate methodology for including non-friction braking to the testing protocol (GRPE-83-20e). The TF4 elaborated on 5 different proposed methodologies which were presented to the IWG on PMP. JRC presented the final proposal to the IWG on PMP in December 2022 (PMP Web Conference 13.12.2022). TF4 concluded its activities for the submission of the GTR on brake emissions in December 2022 having completed 21 meetings. TF4 will continue its activities with a view on a possible amendment of the proposed friction braking share coefficients for calculating PM and PN emissions from non-friction braking.

22. This UN GTR provides all the information necessary to carry out brake particle emissions testing in the laboratory. The main elements of the protocol contained in this UN GTR include:

- (a) References, definitions, and terminology applying to the methodology for sampling and measuring particles from brake wear emissions;
- (b) General requirements and capabilities of the required test setup. Main test conditions for the different elements of the overall setup;
- (c) A detailed description of the WLTP-Brake cycle;
- (d) A detailed description of the different sections of a brake emissions test, including cooling airflow adjustment, bedding procedure, and emissions measurement;
- (e) Minimum requirements to report results from the dynamometer test including actual emissions measurements and metrics.

23. Future work to further expand the protocol contained in this UN GTR might address:

- (a) Definition of a real-world cycle/s for use in the laboratory;
- (b) Adaptation of the proposed methodology to include future technologies;
- (c) Adaptation of the proposed methodology to address brake emissions from heavy-duty vehicles.

## II. Text of the GTR

### 1. Purpose

This Global Technical Regulation (UN GTR) provides a worldwide harmonised methodology for the measurement of brake wear particulate matter and particle number emissions from brakes used on Light-Duty vehicles.

This UN GTR defines the test cycle, minimum system requirements, test conditions, and equipment preparation to execute the WLTP-Brake cycle using brake dynamometers. This UN GTR also provides requirements for the design and set up of test systems to measure brake emissions, including requirements on calibration and validation of test equipment.

### 2. Scope and application

This UN GTR applies to vehicles using some type of friction braking, using a combination of dry friction materials and a mating brake disc or brake drum. This UN GTR applies to vehicles using some form of friction braking in its service braking system or secondary braking system.

This UN GTR applies to category 1-1 and category 2 vehicles with a fully laden mass below 3500 kg. The Contracting Parties shall make a decision about the applicability of this UN GTR to Small Volume Manufacturers for their jurisdiction.

### 3. Definitions

#### 3.1. Vehicle and Brake Dynamometer settings

3.1.1. "*Category 1 vehicle*" means a power-driven vehicle with four or more wheels designed and constructed primarily for the carriage of one or more persons.

3.1.2. "*Category 1-1 vehicle*" means a category 1 vehicle comprising not more than eight seating positions in addition to the driver's seating position. A category 1-1 vehicle may not have standing passengers.

3.1.3. "*Category 2 vehicle*" means a power-driven vehicle with four or more wheels designed and constructed primarily for the carriage of goods. This category shall also include (a) Tractive units and (b) Chassis explicitly designed to be equipped with special equipment.

3.1.4. "*Mass in running order*" is the mass of the vehicle, with its fuel tank(s) filled to at least 90 per cent of its capacity, including the mass of the driver, fuel, and liquids, fitted with the standard equipment in accordance with the manufacturer's specifications and, when they are fitted, the mass of the bodywork, the cabin, the coupling and the spare wheel(s) as well as the tools.

3.1.5. "*Mass of the driver*" means a mass rated at 75 kg located at the driver's seating reference point. In the context of the current regulation, the term "mass of additional 0.5 passengers" means a mass rated at 37.5 kg.

3.1.6. "*Maximum vehicle load*" means the technically permissible maximum laden mass minus the mass in running order, 25 kg, and the mass of the optional equipment.

3.1.7. "*Optional equipment*" means all the features not included in the standard equipment fitted to a vehicle under the manufacturer's responsibility and that the customer can order.



- 3.1.8. "*Standard equipment*" means the basic configuration of a vehicle equipped with all the features required under the regulatory acts of the Contracting Party, including all features that are fitted without giving rise to any further specifications on configuration or equipment level.
- 3.1.9. "*Vehicle test mass*" means the mass in running order plus the mass of the optional fitted equipment to an individual vehicle (kg) on which the tested brake is mounted plus:
- (a) 37.5 kg that corresponds to an additional mass of 0.5 passengers for category 1–1 vehicle (or M1 vehicle category);
  - (b) 25 kg plus 28 per cent of the Maximum Vehicle Load (MVL) for category 2 vehicles with a fully laden mass below 3.5t (or N1 vehicle category).
- 3.1.10. "*Road Loads*" means the total force or power required to move the vehicle on a level and smooth surface at a specified speed and mass. Road loads take account of the frictional losses of the drivetrain. In this UN GTR, a reduction of the brake nominal inertia by a fixed percentage of 13 per cent is considered to account for road loads in full-friction braking emissions testing.
- 3.1.11. "*Tyre dynamic rolling radius*" means the tyre radius that equates to the revolutions per kilometre (or revolutions per mile) published by the tyre manufacturer for the specific tyre size (mm).
- 3.1.12. "*Brake force distribution*" means the ratio between the braking force of each axle and the total braking force expressed as a percentage for each axle.
- 3.1.13. "*Nominal Wheel load*" means the (equivalent) rotating mass as a function of the total vehicle test mass, the axle under test (front or rear), and the brake work distribution among the two axles. It represents the load at the brake corner under testing before accounting for vehicle road loads.
- 3.1.14. "*Test wheel load*" means the (equivalent) rotating mass as a function of the total vehicle test mass, the axle under test (front or rear), and the brake work distribution among the two axles. It represents the load at the brake corner under testing after accounting for vehicle road loads. Also referred to as "*Applied wheel load*".
- 3.1.15. "*Brake nominal inertia*" means the inertia of the wheel load at the radius of gyration equal to the tyre dynamic rolling radius, which imposes the same kinetic energy on the brake as in the actual vehicle before subtracting the total road loads for the vehicle.
- 3.1.16. "*Brake test inertia*" means the inertia of the wheel load at the radius of gyration equal to the tyre dynamic rolling radius, which imposes the same kinetic energy on the brake as in the actual vehicle after subtracting the total road loads for the vehicle. Also referred to as "*Brake applied inertia*".
- 3.1.17. "*Brake torque*" means the product of the frictional forces resulting from the tangential actuating forces in a brake assembly and the distance between the points of generation of these frictional forces and the axis of rotation. The brake torque is a function of the hydraulic piston area, apparent friction coefficient, and the effective brake radius of the brake corner.
- 3.1.18. "*Hydraulic pressure*" means the net pressure supplied by the brake to generate clamping force between the brake and friction material. The hydraulic pressure, combined with the brake's friction coefficient and the effective brake radius, induces the actual brake torque output.
- 3.1.19. "*Threshold pressure*" means the minimum hydraulic pressure to overcome the internal friction and seal forces, move the brake calliper's piston or drum wheel cylinder, and onset brake torque output.

- 3.1.20. "*Piston diameter*" means the diameter of the hydraulic piston(s) in the calliper or drum wheel cylinder and is used to calculate the total piston(s) area. Also referred to as "*Hydraulic piston diameter*".
- 3.1.21. "*Piston area*" means the active area of all hydraulic pistons acting on one side of the brake calliper or drum brake cylinder.
- 3.1.22. "*Effective brake radius*" means for a disc brake, the distance between the centre of rotation and the centreline of the calliper piston(s) when assembled on the fixture. For drum brakes, the effective radius is half of the drum's inner diameter.
- 3.1.23. "*Friction coefficient*" means the ratio between the tangential force and the normal force acting between the brake pad and the disc or the brake shoe and the drum. For a disc brake, the apparent friction coefficient value from the brake under testing is a function of braking torque, effective brake radius, and the piston area. The apparent coefficient of friction is a calculated (mathematical) value and is not directly measurable. Also referred to as "*Brake effectiveness*".
- 3.1.24. "*Brake fluid displacement*" means the transient (volumetric) use of hydraulic fluid by the brake calliper or the brake wheel cylinder during a brake deceleration event.
- 3.1.25. "*Average by time*" means the averaging method for a given measurand through a brake event. The resultant value yields the same result as the integration between two instances (threshold and end of level reached) divided by the duration between the corresponding points.
- 3.1.26. "*Average by distance*" means the averaging method for a given measurand during a brake event. The resultant value yields the same result as the integration between two instances (threshold and end of level reached) divided by the distance travelled (or driven) during this time-lapse.
- 3.1.27. "*Sampling rate*" means the frequency with which the automation system samples the various parameters. It represents the number of events that are measured within 1 second for each parameter.
- 3.1.28. "*Fast sampling rate*" means the sampling rate for the data collection system greater than or equal to 250 Hz. The "fast sampling rate" applies to the dynamometer channels.
- 3.1.29. "*Slow sampling rate*" means the sampling rate for the data collection system that is less than or equal to 10 Hz.

## **3.2. Test setup**

- 3.2.1. "*Brake dynamometer*" means a technical system that imposes, controls, and records the mechanical and electrical work from the brake under testing while operating with a pre-programmed test procedure.
- 3.2.2. "*Torque measurement sensor*" means the electromechanical device that converts the torsional strain on the brake assembly into the equivalent output. The equivalent torque derives from the angular deceleration rate and the effective brake inertia.
- 3.2.3. "*Servo controller*" means a system that modulates the braking torque or hydraulic pressure to the intended (setpoint) value. The servo controller also provides the algorithm to control the release of braking torque or pressure at the end of the brake deceleration events.
- 3.2.4. "*Climatic conditioning unit*" means the air handling system which provides clean, conditioned, and controlled cooling air into the transport duct and the brake enclosure.

- 3.2.5. "*Cooling air*" means the clean, conditioned, and controlled air provided to the brake assembly by the climatic conditioning unit through the ducting as required during the test and described in this UN GTR.
- 3.2.6. "*Cooling air temperature*" means the temperature of the cooling air stream measured upstream of the brake enclosure.
- 3.2.7. "*Cooling air relative humidity*" means the amount of water vapour present in the cooling air stream expressed as a percentage of the amount needed for saturation at the same temperature. It is measured upstream of the brake enclosure.
- 3.2.8. "*Cooling air absolute humidity*" represents the amount of water in grams present in one kilogram of dry air. It is measured upstream of the brake enclosure.
- 3.2.9. "*Cooling airspeed*" means the average speed of the cooling airstream measured in real-time in a length of a straight duct with constant shape and cross-sectional area.
- 3.2.10. "*Cooling airflow*" means the average flow of the cooling airstream provided to the brake assembly.
- 3.2.11. "*Maximum operational flow*" means the maximum cooling airflow that the system can achieve while fulfilling all relevant cooling air conditioning and measurement requirements defined in this UN GTR.
- 3.2.12. "*Minimum operational flow*" means the minimum cooling airflow that the system can achieve while fulfilling all relevant cooling air conditioning and measurement requirements defined in this UN GTR.
- 3.2.13. "*Brake enclosure*" means an aerodynamically designed chamber through which the cooling air enters from one end and exits from the other end. It is an air-tight chamber that prevents untreated air from entering and mixing with the cooling air flowing around the brake assembly. The brake enclosure shrouds the brake assembly.
- 3.2.14. "*Sampling Tunnel*" means a rigid duct connecting the brake enclosure to the sampling plane. It represents the part of the tunnel where the brake particles emitted inside the brake enclosure travel towards the sampling and measurement devices.

### **3.3. Brake hardware**

- 3.3.1. "*Brake under testing*" means the friction brake assembly and its associated vehicle parameters used by the testing facility to measure brake particle emissions according to this UN GTR. Vehicle parameters include those from the vehicle body, powertrain, and other systems that are required to calculate the share of friction braking.
- 3.3.2. "*Brake assembly*" in the case of disc brakes means the set of matching brake discs, brake pads, brake calliper, and associated hardware (to mount, secure, and connect the brake assembly onto the brake fixture and the dynamometer) for a given vehicle and axle application. In the case of drum brakes, the hardware set comprises the brake drum, brake shoes, backplate assembly, and associated hardware (to mount, secure, and connect the brake assembly onto the brake fixture and the dynamometer) for a given vehicle and axle application. The brake assembly mounts on a brake fixture to adapt and connect to the brake dynamometer.
- 3.3.3. "*Service brake*" means the (friction or non-friction) braking system allowing the driver to control, directly or indirectly and in a graduated manner, the speed of a vehicle during normal driving or to bring the vehicle to a halt (standstill).

- 3.3.4. "*Full-friction brake*" means a service brake mounted on a vehicle that uses only the friction between a brake disc or drum and the mating friction materials.
- 3.3.5. "*Brake fixture*" means a mechanical device or jig to mount the brake assembly by connecting the tailstock (or non-rotating surface) to the brake dynamometer shaft (rotating). The tailstock side (or non-rotating surface) absorbs the braking torque and associated tangential forces. The rotating shaft transmits the kinetic energy from the brake test inertia to the brake assembly.
- 3.3.6. "*Universal style fixture*" means a brake fixture cylindrical and symmetrical without additional extensions or protrusions different from those needed to mount the brake assembly. A wheel hub is not included in the assembly.
- 3.3.7. "*Post style fixture*" means a dynamometer fixture that uses round and stiff tubing and adaptors, instead of the vehicle knuckle, to mount the brake assembly. A wheel hub is attached to complete the assembly.
- 3.3.8. "*Brake calliper*" means a mechanical device that converts driver brake pedal input into a clamping force on the brake pads to generate braking torque.
- 3.3.9. "*Brake disc*" means a rotating, wearable device against which the brake calliper clamps the brake pads in a disc brake assembly. This device acts as the primary heat absorption and dissipation device as the brake corner transforms vehicle kinetic energy into heat.
- 3.3.10. "*Brake pad*" means a wearable device that mounts onto the brake calliper consisting of a structural (metal) pressure plate and a friction material element. The brake pads clamp against the brake disc, generating a retarding friction force and thus the brake torque.
- 3.3.11. "*Brake drum*" means a rotating, wearable mechanism against which the brake wheel cylinder clamps the brake shoes in a drum brake assembly. This device acts as the primary heat absorption and dissipation device as the brake corner translates vehicle kinetic energy into heat.
- 3.3.12. "*Brake shoe*" means a wearable device consisting of an arced structural metal shoe and a (bonded or riveted) friction material. The brake shoe is clamped against the drum to generate friction and thus brake torque.
- 3.3.13. "*Friction material part number*" means the unique edge code to identify the specific friction material supplier, formulation, and environmental marking.
- 3.3.14. "*Disc or drum part number*" means the unique code labelled by the manufacturer to identify the specific disc or drum.
- 3.3.15. "*Brake runout*" means the total lateral displacement of a spot located either 10 mm radially outwards from the centreline of the outboard braking surface of the brake disc or the total radial displacement of a spot located on the centreline of the inner rubbing surface of the brake drum during one complete revolution.
- 3.3.16. "*Running clearance*" means the axial distance between the braking surface of the disc and the brake pad during one complete revolution with the brake released. For drum brakes, it is the radial distance between the inner diameter of the drum and the brake shoe.
- 3.4. WLTP-Brake Cycle**
- 3.4.1. "*Driving cycle*" means a series of data points representing the speed of a vehicle versus time. The driving cycle consists of individual trips and each trip consists of a series of separate and consecutive events. These events include brake dwell, acceleration, cruising, and deceleration.
- 3.4.2. "*WLTP-Brake cycle*" means the driving cycle derived from the vehicle activity of the Worldwide Light vehicle Test Procedure database with a total duration

of 15 826 seconds plus the cooling sections in-between trips. The cycle comprises ten trips and 303 brake deceleration events.

- 3.4.3. "*Brake emissions test*" means a sequence of three sections (cooling air adjustment, brake bedding, and brake emissions measurement) to characterise the particle emissions of the brake under testing.
- 3.4.4. "*Cooling air adjustment*" means the section that follows a procedure with the brake under testing to define the appropriate incoming cooling airflow for the bedding and emissions measurement sections. Also referred to as the "*Cooling adjustment section*".
- 3.4.5. "*Brake bedding*" means the section with a sequence of brake events to develop a brake with a stable transfer layer, brake effectiveness, and brake emissions behaviour before conducting the brake emissions measurement section. Also referred to as the "*Bedding procedure*" or "*Bedding section*".
- 3.4.6. "*Brake emissions measurement*" means the section of the brake emissions test where PM and PN emissions are sampled and measured. Also referred to as the "*Emissions measurement section*".
- 3.4.7. "*Brake acceleration event*" means a measurable period during which the linear speed increases to a predetermined set value at a known rate. This event always precedes a brake cruising or a brake deceleration event.
- 3.4.8. "*Brake cruising event*" means a measurable period during which the (non-zero) linear speed is constant.
- 3.4.9. "*Brake dwell event*" means a measurable and predictable brake pause at zero speed during the cycle.
- 3.4.10. "*Brake deceleration event*" means a measurable period during which the linear speed decreases at a known rate to a predetermined release speed during the cycle.
- 3.4.11. "*Deceleration rate*" means the total rate of reduction in the linear speed of the vehicle induced by the application of the service brake, the road loads, and the non-friction torque from the electric machine.
- 3.4.12. "*Brake stop*" is the generic term denoting a brake deceleration event that brings the vehicle to a halt or standstill.
- 3.4.13. "*Brake snub*" means the generic term used to denote a brake deceleration event that reduces the vehicle speed to a non-zero level.
- 3.4.14. "*Soaking section*" means the section in-between trips when the brake is rotating at low speed (approximately five or fewer revolutions per minute) waiting for the brake to cool down and the initial brake temperature to reach the predefined level for commencing the next cycle trip.
- 3.4.15. "*Initial speed*" means the speed of the vehicle at the start of a brake deceleration event.
- 3.4.16. "*Release speed*" means the speed of the vehicle at the end of a brake deceleration event.
- 3.4.17. "*Nominal linear speed*" means the target (or set) speed of the vehicle at the time  $i$  per the WLTP-Brake cycle.
- 3.4.18. "*Actual linear speed*" means the linear speed of the vehicle at the time  $i$  during the test cycle execution. Also referred to as "*Measured speed*".
- 3.4.19. "*Speed violation*" means any instance when the actual dynamometer speed trace exceeds the speed trace tolerances prescribed in this UN GTR during the WLTP-Brake cycle.
- 3.4.20. "*Initial brake temperature*" means the bulk temperature of the brake disc or brake drum at the start of a given brake event during the WLTP-Brake cycle.

- 3.4.21. "*Final brake temperature*" means the bulk temperature of the brake disc or brake drum at the end of a given brake event during the WLTP-Brake cycle.
- 3.4.22. "*Average brake temperature*" means the average of the time-resolved brake disc or brake drum temperature during a predetermined period.
- 3.4.23. "*Peak brake temperature*" means the highest brake disc or drum temperature measured during a given brake event.

### 3.5. PM and PN Measurement

- 3.5.1. The term "*particle*" is conventionally used for the matter being characterised (measured) in the airborne phase (suspended matter), and the term "particulate matter" for the deposited matter.
- 3.5.2. "*Particle number emissions*" means the number of particles emitted from the brake under testing and quantified according to the dilution, sampling, and measurement methods specified in this UN GTR.
- 3.5.3. "*Total particle number emissions*" means the number of total particles (i.e. solids and volatiles) emitted from the brake under testing.
- 3.5.4. "*TPN10*" means the number of total particles (i.e. solids and volatiles) at a nominal particle size of approximately 10 nm electrical mobility diameter and larger emitted from the brake under testing and quantified according to the dilution, sampling, and measurement methods specified in this UN GTR.
- 3.5.5. "*Solid particle number emissions*" means the number of solid particles emitted from the brake under testing.
- 3.5.6. "*SPN10*" means the number of solid particles at a nominal particle size of approximately 10 nm electrical mobility diameter and larger emitted from the brake under testing and quantified according to the dilution, sampling, and measurement methods specified in this UN GTR.
- 3.5.7. "*Particulate matter (PM) emissions*" means the mass of any particle from the brake under testing quantified according to the dilution, sampling, and measurement methods specified in this UN GTR.
- 3.5.8. "*PM<sub>2.5</sub> emissions*" means the PM with an aerodynamic diameter of approximately 2.5 µm or less.
- 3.5.9. "*PM<sub>10</sub> emissions*" means the PM with an aerodynamic diameter of approximately 10 µm or less.
- 3.5.10. "*Sampling plane*" means the fixed plane (perpendicular to the sampling tunnel axis) where the entries of the sampling nozzles are located.
- 3.5.11. "*Sampling probe*" means a thin-walled stainless steel tube designed to extract and transfer a representative portion of aerosol from the sampling tunnel to the measurement system.
- 3.5.12. "*Sampling nozzle*" means a thin-walled stainless steel cylinder with a knife-edge nozzle tip that mounts at the inlet of a sampling probe and aims to extract isokinetically aerosol from the sampling tunnel.
- 3.5.13. "*Sampling nozzle tip*" means the upstream cross-section of the sampling nozzle where the aerosol enters the sampling nozzle.
- 3.5.14. "*PM Sampling system*" means the series of elements where aerosol travels after entering the sampling nozzle tip. It includes – in the direction of the flow – the PM sampling nozzle, the PM sampling probe, the PM separation device, the PM sampling line, and the filter holder.
- 3.5.15. "*PM separation device*" means a device that separates the relevant portion of PM from the aerosol according to the specifications of this UN GTR.

- 3.5.16. "*Separation efficiency*" means the ratio of particles removed by the separation device to the overall particles entering the separation device at a given aerodynamic diameter.
- 3.5.17. "*PM Sampling line*" means the rigid or flexible tubing connecting the outlet of the PM separation device to the inlet of the filter holder.
- 3.5.18. "*Filter holder*" means a device that allows the collection of PM on filters according to the specifications of this UN GTR.
- 3.5.19. "*PN Sampling system*" means the series of elements where aerosol travels after entering the sampling nozzle tip. It includes – in the direction of the flow – the PN sampling nozzle, the PN sampling probe, the PN pre-classifier, the particle transfer tube, the flow splitting device (if applicable), and the PN measurement system.
- 3.5.20. "*Particle transfer tube*" means the flexible tubing connecting the PN sampling probe's outlet to the PN pre-classifier's inlet. When the PN pre-classifier is directly connected to the PN sampling probe's outlet, the particle transfer tube means the flexible tubing connecting the PN pre-classifier's outlet to the PN measurement system's inlet.
- 3.5.21. "*PN measurement system*" means the system that allows the determination of the particle number concentrations according to this UN GTR. It includes the sample conditioning system, the PN internal transfer lines, and the particle number counter.
- 3.5.22. "*Sample conditioning system*" means the parts of the PN measurement systems that dilute and condition the aerosol to be provided to the particle number counter to determine TPN10 and SPN10, respectively.
- 3.5.23. "*Particle number counter*" means a device to determine particle number concentration according to the specifications of this UN GTR.
- 3.5.24. "*Standard conditions*" means pressure equal to 101.325 kPa and temperature corresponding to 273.15 K.
- 3.5.25. "*Background emissions*" means the measurement of particle number concentrations using the same instrumentation as for emission testing when the environmental conditioning system and the dynamometer cooling air are running under the test conditions, without any brake applications or brake rotation to influence the result.
- 3.6. Test system**
- 3.6.1. "*Calibration*" means the process of setting a measurement system's response so that its output agrees with a reference value.
- 3.6.2. "*Major maintenance*" means the adjustment, repair, or replacement of a component or module that could affect the accuracy of a measurement.
- 3.6.3. "*Reference value*" means a value traceable to a national or international standard.
- 3.6.4. "*Setpoint*" means the target value a control system aims to reach.
- 3.6.5. "*Verification*" means evaluating whether a measurement system's outputs agree with applied reference values within one or more predetermined thresholds for acceptance.
- 3.6.6. "*Response time*" means the difference in time between the change of the component to be measured at the reference point and a measurement system's response of 90 per cent of the final reading ( $t_{90}$ ) with the sampling nozzle inlet being defined as the reference point, whereby the change of the measured component is at least 60 per cent full scale (FS) and takes place in less than 0.1 seconds. The response time consists of the delay time to the system and of the rise time of the system.

- 3.6.7. "Fall time" means the difference in time between  $t_{90}$  and  $t_{10}$ , where the change of the measured component is at the reference point falls from 90 per cent of initial reading to 10 per cent of initial reading, if the change of the set signal takes place in less than 0.1 seconds.
- 3.6.8. "Drift" means the change of the measured signal over a defined time period for a specific setpoint due to influences such as temperature, pressure, voltage, current, etc.
- 3.7. Non-friction braking**
- 3.7.1. "Friction braking" in the context of this UN GTR means the decelerating of the vehicle by using the friction braking system where the brake forces are generated by friction between two parts of the vehicle moving relative to one another.
- 3.7.2. "Non-friction braking" in the context of this UN GTR means the decelerating of the vehicle also by different technical means without using solely the friction braking system, e.g. such as regenerative braking. It applies to pure electric vehicles and hybrid electric vehicles with a traction REESS nominal voltage greater than 20V.
- 3.7.3. "Full-friction braking" in the context of this UN GTR means the decelerating of the vehicle by using only a full-friction brake system.
- 3.7.4. "Electric machine" means an energy converter transforming between electrical and mechanical energy.
- 3.7.5. "Category of propulsion energy converter" means (i) an internal combustion engine, or (ii) an electric machine.
- 3.7.6. "Hybrid electric vehicle" (HEV) means a hybrid vehicle where one of the propulsion energy converters is an electric machine.
- 3.7.7. "Hybrid vehicle" means a vehicle equipped with a powertrain containing at least two different categories of propulsion energy converters and at least two different categories of propulsion energy storage systems.
- 3.7.8. "Not off-vehicle charging hybrid electric vehicle" (NOVC-HEV) means a hybrid electric vehicle that cannot be charged from an external source. In this UN GTR, NOVC-HEV are categorised to "NOVC-HEV Category 1" and "NOVC-HEV Category 2" based on their traction REESS nominal voltage.
- 3.7.8.1. "Not off-vehicle charging hybrid electric vehicle – Category 1" (NOVC-HEV Cat. 1) means a hybrid electric vehicle that features a traction REESS with a nominal voltage higher than 20V and lower than or equal to 60V that cannot be charged from an external source.
- 3.7.8.2. "Not off-vehicle charging hybrid electric vehicle – Category 2" (NOVC-HEV Cat. 2) means a hybrid electric vehicle that features a traction REESS with a nominal voltage higher than 60V that cannot be charged from an external source.
- 3.7.9. "Off-vehicle charging hybrid electric vehicle" (OVC-HEV) means a hybrid electric vehicle that can be charged from an external source.
- 3.7.10. "Pure electric vehicle" (PEV) means a vehicle equipped with a powertrain containing exclusively electric machines as propulsion energy converters and exclusively rechargeable electric energy storage systems as propulsion energy storage systems.
- 3.7.11. "Pure internal combustion engine vehicle" (ICE) means a vehicle where all propulsion energy converters are internal combustion engines.
- 3.7.12. "Rechargeable electric energy storage system – REESS" means the rechargeable electric energy storage system that provides electric energy for electric propulsion.



- 3.7.13. "Brake Emissions Family Parent" is a single vehicle selected among a family of two or more vehicles equipped with the same brake system.

## 4. Abbreviations and Symbols

### 4.1. Abbreviations

Table 4.1. provides a list of the abbreviations, a short description, and the unit of each abbreviation (when applicable) used in this UN GTR.

Table 4.1.  
**Abbreviations**

<i>Abbreviation</i>	<i>Definition</i>	<i>Unit</i>
<i>ABT</i>	Average Brake Temperature during Trip #10	°C
<i>AH</i>	Absolute humidity	mg H <sub>2</sub> O/kg dry air
<i>BRO</i>	Brake runout	µm
<i>CSV</i>	Comma-separated values	-
<i>DM</i>	Disc mass before testing	kg
<i>DOP</i>	Diocetyl phthalate	-
<i>ECE</i>	Economic Commission for Europe	-
<i>EF</i>	Emission factor	-
<i>EN</i>	"European Norm" - European technical standard	-
<i>FA</i>	Vehicle front axle	-
<i>FAF</i>	Front axle brake force distribution	%
<i>FBT</i>	Final brake temperature at the end of the brake event	°C
<i>H13</i>	High-efficiency air filter with a filtering efficiency of at least 99.95 per cent	-
<i>HEPA</i>	High-efficiency particulate filter	-
<i>IBT</i>	Initial brake temperature at the start of the brake event	°C
<i>ICE</i>	Internal combustion engine	-
<i>IR</i>	Isokinetic ratio	-
<i>L0-P</i>	Post-style brake fixture with wheel hub connection	-
<i>L0-U</i>	Universal-style brake fixture without wheel hub connection	-
<i>LHC</i>	Left-hand corner of the vehicle	-
<i>MRO</i>	Mass in running order	kg
<i>MVL</i>	Maximum vehicle load	kg
<i>NOVC-HEV</i>	Not off-vehicle charging hybrid electric vehicle	-
<i>NOVC-HEV Cat.1</i>	Not off-vehicle charging hybrid electric vehicle category 1	-
<i>NOVC-HEV Cat.2</i>	Not off-vehicle charging hybrid electric vehicle category 2	-
<i>OD</i>	Disc/drum outer diameter	mm

<i>Abbreviation</i>	<i>Definition</i>	<i>Unit</i>
<i>ODS</i>	Open document spreadsheet	-
<i>OVC-HEV</i>	Off-vehicle charging hybrid electric vehicle	-
<i>PEV</i>	Pure electric vehicle	-
<i>Plane A</i>	Vertical plane aligned with the enclosure's inlet	-
<i>Plane A<sub>1</sub></i>	Horizontal level aligned with the axis of the brake rotation and the duct axis	-
<i>Plane B</i>	Vertical plane at the end of the transition from the inlet duct to the central section of the enclosure, perpendicular to the duct axis	-
<i>Plane C</i>	Vertical plane tangential to the largest brake for M1, N1 vehicle category, perpendicular to the duct axis	-
<i>Plane D</i>	Vertical plane aligned with the axis of the brake rotation	-
<i>PND1</i>	Primary particle number diluter	-
<i>PND2</i>	Secondary particle number diluter	-
<i>PAO</i>	poly-alpha-olefin	-
<i>PBT</i>	Peak brake temperature of the brake event	°C
<i>PCRF</i>	Particle concentration reduction factor	-
<i>PM</i>	Particulate matter mass	mg
<i>PM<sub>2.5</sub></i>	Particulate Matter mass for aerosols with aerodynamic diameter below 2.5 µm	mg
<i>PM<sub>2.5</sub> EF<sub>ref</sub></i>	Reference PM <sub>2.5</sub> emission factor of the tested brake before applying the friction braking share coefficient	mg/km
<i>PM<sub>2.5</sub> EF</i>	Final PM <sub>2.5</sub> emission factor	mg/km
<i>PM<sub>10</sub></i>	Particulate Matter mass for aerosols with aerodynamic diameter below 10 µm	mg
<i>PM<sub>10</sub> EF<sub>ref</sub></i>	Reference PM <sub>10</sub> emission factor of the tested brake before applying the friction braking share coefficient	mg/km
<i>PM<sub>10</sub> EF</i>	Final PM <sub>10</sub> emission factor	mg/km
<i>PN</i>	Particle number	#
<i>PNC</i>	Particle number counter	-
<i>PTFE</i>	Poly tetra fluoroethylene	-
<i>PTT</i>	Particle transfer tube	-
<i>RA</i>	Vehicle rear axle	-
<i>RAF</i>	Rear axle brake force distribution	%
<i>REESS</i>	Rechargeable electric energy storage system	-
<i>RH</i>	Relative humidity	%
<i>RHC</i>	Right-hand corner of the vehicle	-
<i>SPN10</i>	Solid particle number concentration of particles larger than 10nm	#/cm <sup>3</sup>
<i>SPN10 EF<sub>ref</sub></i>	Reference SPN10 emission factor of the tested brake before applying the friction braking share coefficient	#/km
<i>SPN10 EF</i>	Final SPN10 emission factor	#/km
<i>SAE</i>	Society of Automotive Engineers	-
<i>SEE</i>	Standard error of estimate	-

<i>Abbreviation</i>	<i>Definition</i>	<i>Unit</i>
<i>TPN10</i>	Total particle number concentration of particles larger than 10nm	#/cm <sup>3</sup>
<i>TPN10 EF<sub>ref</sub></i>	Reference TPN10 emission factor of the tested brake before applying the friction braking share coefficient	#/km
<i>TPN10 EF</i>	Final TPN10 emission factor	#/km
<i>ULPA</i>	Ultra-low particulate air	-
<i>UN GTR</i>	United Nations Global technical regulation	-
<i>VPR</i>	Volatile particle remover	-
<i>WLTP</i>	World-wide harmonized light vehicle test procedure	-

#### 4.2. Symbols

Table 4.2. provides a list of the symbols, a short description, and the units of the symbols as applied in this UN GTR.

Table 4.2.  
Symbols

<i>Symbol</i>	<i>Definition</i>	<i>Unit</i>
<i>a</i>	Transition angle of the brake enclosure	°
<i>a<sub>1</sub></i>	The minimum distance between the sampling probes	mm
<i>a<sub>2</sub></i>	The minimum distance between the sampling probes and the tunnel walls	mm
<i>a</i>	Deceleration	m/s <sup>2</sup>
<i>A<sub>1...3</sub></i>	Metrics for target temperatures	°C
<i>B<sub>1...3</sub></i>	Metrics for measured temperatures	°C
<i>C<sub>1...3</sub></i>	Metrics for the temperature difference between target and measured values	°C
<i>c</i>	Friction braking share coefficient	-
<i>d</i>	Total distance driven over Trip #10 or the WLTP-Brake cycle	km
<i>d<sub>i</sub></i>	Sampling tunnel inner diameter	mm
<i>d<sub>n</sub></i>	Sampling nozzle inner diameter (applies to both PN and PM)	mm
<i>d<sub>n-PM2.5</sub></i>	The inner diameter of the isokinetic nozzle for sampling PM <sub>2.5</sub>	mm
<i>d<sub>n-PM10</sub></i>	The inner diameter of the isokinetic nozzle for sampling PM <sub>10</sub>	mm
<i>d<sub>n-SPN10</sub></i>	The isokinetic nozzle's inner diameter for SPN10 sampling	mm
<i>d<sub>n-TPN10</sub></i>	The isokinetic nozzle's inner diameter for TPN10 sampling	mm
<i>d<sub>piston</sub></i>	Calliper piston hydraulic diameter	mm
<i>d<sub>p</sub></i>	Sampling probes inner diameter (applies to both PN and PM)	mm
<i>d<sub>s</sub></i>	The inner diameter of the PM sampling line	mm
<i>d<sub>tl</sub></i>	The inner diameter of the PN internal transfer line	mm
<i>d<sub>tt</sub></i>	The inner diameter of the PN transfer tube	mm
<i>d<sub>x</sub></i>	Electrical mobility diameter	µm

<i>Symbol</i>	<i>Definition</i>	<i>Unit</i>
$\eta$	Brake calliper or drum efficiency	%
$f$	Brake rotational speed	rev/min
$f_r(d_x)$	PCRF for each particle of electrical mobility diameter $d_x$	-
$f_{r-SPN10}$	Arithmetic averaged PCRF for the SPN10 measuring device	-
$f_{r-TPN10}$	Arithmetic averaged PCRF for the TPN10 measuring device	-
$h_B$	Length of Plane B (enclosure)	mm
$h_D$	Length of Plane D (enclosure)	mm
$H_e$	The point that defines the end of the mandatory horizontal part in the layout	-
$H_s$	The point that defines the start of the mandatory horizontal part in the layout	-
$I_n$	Brake nominal inertia	kg·m <sup>2</sup>
$I_t$	Brake test inertia	kg·m <sup>2</sup>
$l_{A1}$	Length of plane A <sub>1</sub> (enclosure)	mm
$l_i$	Length of inlet or outlet transition of brake enclosure	mm
$l_1$	Height of the enclosure at Plane C	mm
$l_2$	Depth of the enclosure at Plane C	mm
$L_1$	Minimum length of the straight duct upstream of the inlet of the brake enclosure	mm
$L_2$	Minimum length of the straight duct from the last disturbance upstream of the sampling plane to the sampling plane	mm
$L_3$	Minimum length of the straight duct from the sampling plane to the next disturbance downstream of the sampling plane	mm
$L_4$	Minimum length of the straight duct from the last disturbance upstream of the airflow measurement element to the airflow measurement element	mm
$L_5$	Minimum length of the straight duct from the airflow measurement element to the next disturbance	mm
$\mu$	Average by distance friction variable for disc brakes (Friction Coefficient)	-
$M_{Mix}$	The molar mass of air in the balance room	g/mol
$M_{veh}$	Vehicle test mass to simulate on the dynamometer	kg
$\nu$	Kinematic viscosity of air	m <sup>2</sup> /s
$N_{in}(d_x)$	Upstream PN concentration for particles of electrical mobility $d_x$	#/cm <sup>3</sup>
$N_{out}(d_x)$	Downstream PN concentration for particles of electrical mobility $d_x$	#/cm <sup>3</sup>
$NQ$	Average normalised cooling airflow	Nm <sup>3</sup> /h
$NQ_{PM2.5}$	Average normalised PM <sub>2.5</sub> sampling flow	l/min
$NQ_{PM10}$	Average normalised PM <sub>10</sub> sampling flow	l/min
$NQ_{TPN10}$	Average normalised TPN10 sampling flow	l/min
$NQ_{SPN10}$	Average normalised SPN10 sampling flow	l/min
$NQ_s$	Average normalised airflow in the sampling nozzle	Nm <sup>3</sup> /h
$P_b$	Atmospheric pressure in the balance room	kPa
$P_{brake}$	Brake pressure	kPa

<i>Symbol</i>	<i>Definition</i>	<i>Unit</i>
$P_r$	Particle penetration	%
$p_{threshold}$	Threshold pressure required to develop braking torque	kPa
$Pe_{(2.5)}$	PM <sub>2.5</sub> filter load corrected for buoyancy	mg
$Pe_{(10)}$	PM <sub>10</sub> filter load corrected for buoyancy	mg
$Pe_{(Corrected)}$	Buoyancy-corrected filter mass	mg
$Pe_{(Uncorrected)}$	Filter mass without buoyancy correction	mg
$Q$	Average measured (actual) cooling airflow	m <sup>3</sup> /h
$Q_{set}$	Nominal (or set) cooling airflow	m <sup>3</sup> /h
$Q_{PM2.5}$	PM <sub>2.5</sub> sampling flow (actual)	l/min
$Q_{PM2.5-set}$	Nominal (or set) PM <sub>2.5</sub> sampling flow	l/min
$Q_{PM10}$	PM <sub>10</sub> sampling flow (actual)	l/min
$Q_{PM10-set}$	Nominal (or set) PM <sub>10</sub> sampling flow	l/min
$r_b$	Bending radius of the cooling air duct	mm
$r_{eff}$	Brake effective radius	mm
$r_P$	Bending radius of the sampling probe or sampling line	mm
$r_R$	Tyre dynamic rolling radius	mm
$\rho_a$	Density of air	kg/m <sup>3</sup>
$\rho_f$	The density of PM filter material	kg/m <sup>3</sup>
$\rho_w$	The density of the PM microbalance calibration object	kg/m <sup>3</sup>
$SPN_{10\#}$	Average normalised and PCRF-corrected SPN10 concentration	#/Ncm <sup>3</sup>
$SPN_{10back}$	Average normalised SPN10 concentration during the background check	#/Ncm <sup>3</sup>
$SPN_{10b\ EF}$	Average SPN10 count per unit distance driven during the background check	#/km
$S_p$	Output signal for cooling air pressure	kPa
$S_Q$	Output signal for cooling airflow	m <sup>3</sup> /h
$S_{RH}$	Output signal for cooling air relative humidity	%
$S_t$	Output signal for cooling air temperature	°C
$t_{brake}$	The total duration of the deceleration event (stop duration)	s
$t_{90}$	Response time of particle number counter	s
$\tau_{brake}$	Brake torque	N·m
$\tau_{brake-avg}$	Time-averaged brake torque	N·m
$T$	Cooling air temperature	°C
$T_a$	Air temperature in the balance room	°C
$T_{brake}$	Brake (disc/drum) temperature	°C
$TPN_{10\#}$	Average normalised and PCRF-corrected TPN10 concentration	#/Ncm <sup>3</sup>

<i>Symbol</i>	<i>Definition</i>	<i>Unit</i>
$TPN10_{back}$	Average normalised TPN10 concentration during the background check	$\#/Ncm^3$
$TPN10_{b,EF}$	Average TPN10 count per unit distance driven during the background check	$\#/km$
$U$	Average cooling airspeed	km/h
$U_s$	Average airspeed of air entering the sampling nozzle	km/h
$V$	Average actual linear speed of the WLTP-Brake cycle	km/h
$V_{set}$	The average nominal linear speed of the WLTP-Brake cycle	km/h
$W_f$	Specific friction work	J/kg
$WL_n$	Nominal wheel load without accounting for vehicle road loads or any other type of losses	kg
$WL_{n-f}$	Nominal front wheel load without accounting for vehicle road loads or any other type of losses	kg
$WL_{n-r}$	Nominal rear wheel load without accounting for vehicle road loads or any other type of losses	kg
$WL_t$	Test wheel load after accounting for vehicle road loads or any other type of losses	kg
$WL_{t-f}$	Test front wheel load after accounting for vehicle road loads or any other type of losses	kg
$WL_{t-r}$	Test rear wheel load after accounting for vehicle road loads or any other type of losses	kg

## 5. General Requirements

### 5.1. Compliance Requirements

The compliance of a brake with this UN GTR shall be evaluated against the regional emission limits as defined by each Contracting Party. The compliance shall be demonstrated by testing the worst-performing representative of a brake family according to paragraphs 6-14 of this UN GTR.

### 5.2. Brake Emissions Family

A brake emissions family is defined by a brake assembly considering the calliper, disc or drum-backplate assembly, pad or shoe, and certain other vehicle parameters.

#### 5.2.1. Characteristics of Brake Emissions Families

All vehicle types independent of their electrification grade may be part of one brake emissions family. Only vehicles that feature an identical brake assembly with respect to the characteristics listed in (a)-(d) may be part of the same brake emissions family. The eligibility criteria for becoming a part of the brake emissions family may be extended in the first amendment to this UN GTR:

- (a) Type of calliper (floating or fixed calliper, number and size of pistons, type of retraction elements);
- (b) Type of brake: disc (friction surface, coating, single, dual, ventilated, solid, dimensions, mass, material formulation) or drum-backplate assembly (friction surface, simplex, duplex, dimensions, mass, material formulation);
- (c) Type of friction material: pad (friction surface, size, shape, material, backing plate, material formulation) or shoe (friction surface, size, design, material, backing plate, material formulation);
- (d) Any other characteristic that has a non-negligible influence on brake emissions (e.g. innovative brake emission reduction systems).

### 5.2.2. Brake Emissions Family Parent

For all vehicles with an identical brake assembly as described in paragraph 5.2.1., the vehicle with the highest product of friction braking share coefficient ( $c$ ) and test wheel load as defined in paragraph 3.1.14. ( $WL_t * c$ ) shall be selected as parent of the brake emissions family. The friction braking share coefficient for each vehicle type in the scope of this UN GTR is given in Table 5.1. If the product of the test wheel load and the friction braking share coefficient is the same for two or more vehicles of the same brake emissions family, the vehicle with the lowest dynamic rolling radius shall be selected as the brake emissions family parent.

Table 5.1.

**Friction braking share coefficients for all vehicle types**

<i>Brake type</i>	<i>Vehicle Type</i>	<i>Friction Braking Share Coefficient (c)</i>
Full-friction braking	ICE and other vehicle types not covered in the non-friction braking categories in this Table	1.0
Non-friction braking	NOVC-HEV Cat.1	0.63
	NOVC-HEV Cat.2	0.45
	OVC-HEV	0.30
	PEV	0.15

*Note:* A detailed testing methodology to determine vehicle-specific friction braking share coefficients will be included in the first amendment to this UN GTR.

The product of friction braking share coefficient and test wheel load shall be used only to identify the brake emissions family parent and not as input parameter when testing the brake assembly for its emissions. The brake assembly shall be tested on the test stand using the test wheel load corresponding to the brake emissions family parent as described in paragraph 8.1.1. (when the family parent is a pure ICE vehicle) or in paragraph 8.1.2. (when the family parent is a NOVC-HEV, OVC-HEV, or PEV) of this UN GTR.

The final brake PM and PN emission factors for the brake emissions family parent are calculated after multiplying the reference PM and PN emissions of the tested brake with the  $c$  value of the brake emissions family parent vehicle as described in paragraphs 12.1.5. and 12.2.4. of this UN GTR, respectively.

### 5.3. Rounding Requirements

All data must be processed using at least six significant digits. If fewer significant digits are available, data must be processed using all available significant digits. Rounding of intermediate results is not permitted. The final values for a given parameter may be rounded to the number of significant digits necessary to match the number of decimal places defined for the parameter in paragraph 13. of this UN GTR.

## 6. General Overview

### 6.1. Test sections

A brake emissions test includes three test sections. Each section contains one or more trips with a series of events. The main events which induce brake work and generate brake emissions are the deceleration events. Figure 6.1. provides a schematic overview of a brake emissions test.

Figure 6.1.

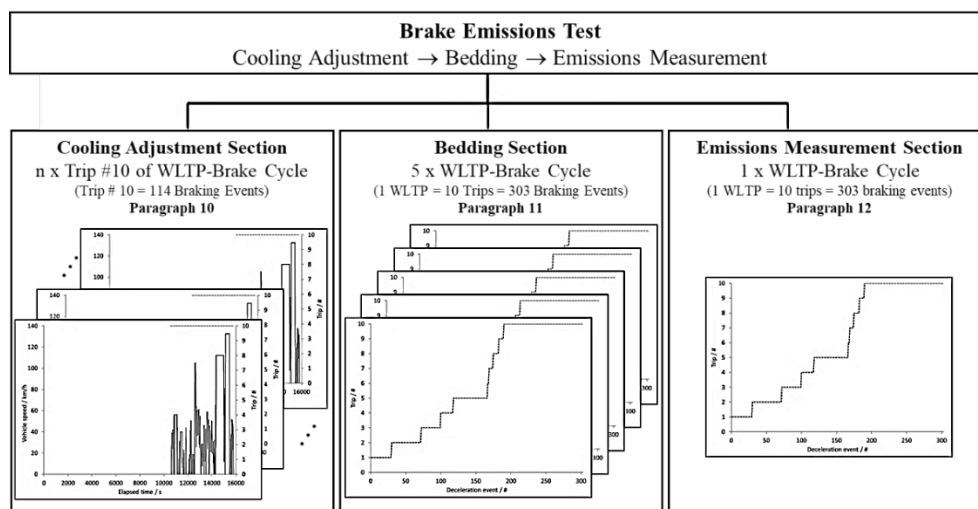
**Structure of the brake emissions tests for vehicles with full-friction braking**

The three sections of the brake emissions test are:

- Brake cooling adjustment. This section uses Trip #10 of the WLTP-Brake cycle. The cooling adjustment section is described in detail in paragraph 10.;
- Brake bedding. This section uses five repetitions of the WLTP-Brake cycle. The bedding section is described in detail in paragraph 11.;
- Brake emissions measurement. This section includes one performance of the WLTP-Brake cycle. The emissions measurement section is described in detail in paragraph 12.

**6.2. Test execution steps**

The correct execution of a brake emissions test requires the testing facility to conduct and document the following steps:

- Ensure the test system meets the requirements defined in paragraph 7. regarding the system layout, cooling airflow, temperature and humidity control, brake dynamometer capabilities, brake enclosure design, sampling tunnel design, and sampling plane design;
- Meet all requirements defined in paragraph 8. for test preparation involving the calculation and application of the correct input parameters, test setup, measurement of brake temperature, and brake positioning in the enclosure;
- Be capable of executing the WLTP-Brake cycle per paragraph 9. and demonstrate compliance with the quality checks;
- Perform the brake cooling adjustment section as defined in paragraph 10.;
- Perform the brake bedding section as defined in paragraph 11.;
- Execute all items from paragraph 12. for the brake emissions measurement, including particulate matter mass, particle number, and mass loss of the wearable brake hardware;
- Report the results of the test following paragraph 13.;
- Comply with Paragraph 14. for minimum calibration requirements and periodic evaluations of the used instrumentation and setup.



## 7. Test System Requirements

### 7.1. Overall Test System Layout

This UN GTR defines a standard dynamometer test method aiming for repeatable and reproducible measurements of particle emissions from brakes. The technical system to perform brake emissions tests requires a system approach. The execution of a valid brake emissions test requires a robust integration of several subsystems to ensure the drive cycle, cooling air, dynamometer control, brake enclosure, sampling tunnel, aerosol sampling systems, and data collection, altogether meet the requirements specified in this UN GTR.

Figure 7.1.

#### Indicative layout for performing brake emissions test in the laboratory

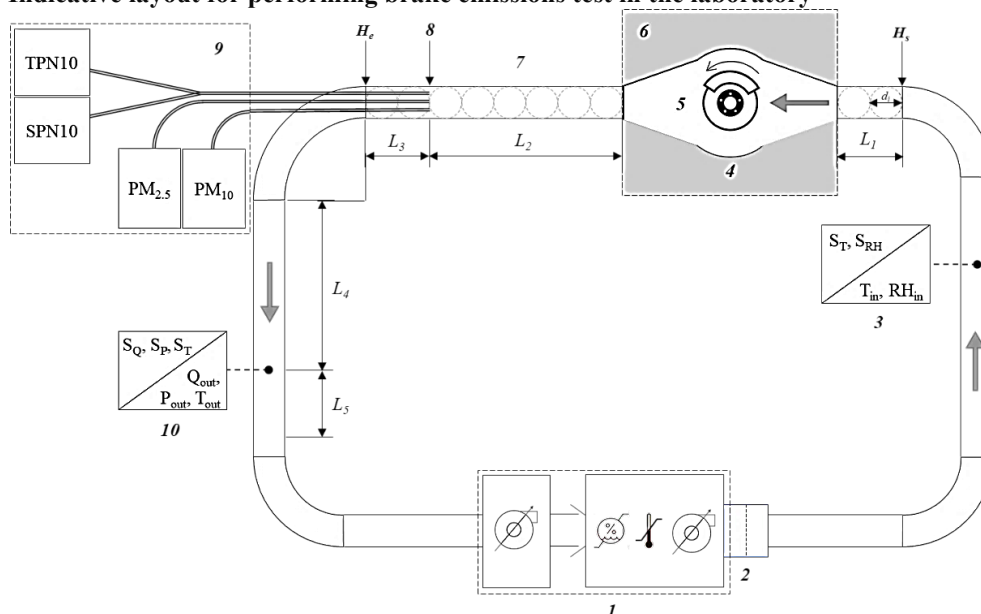

*Note:* The layout has the sampling tunnel connected directly to the brake enclosure and assumes three sampling probes (a four-sampling probe layout is also feasible). A layout with a bend in the sampling tunnel is also feasible i.e. downstream of the enclosure and upstream of the sampling plane. The brake dynamometer is not depicted but only denoted (grey area) – a graphical representation of the brake dynamometer is given in Figure 7.2.

Figure 7.1. provides a layout that includes the minimum required subsystems to carry out a brake emissions test using a brake dynamometer. The illustrated layout features a climatic conditioning unit with variable flow fan(s) that supplies the setup with conditioned air. The conditioned air enters a brake enclosure designed to fit the entire assembly of the brake under testing. The brake dynamometer enables and controls the testing of the brake. The enclosure is directly connected to the sampling tunnel near the end of which three (or four) sampling probes are mounted. The sampling probes are used to extract the aerosol from the tunnel towards the PM and PN measurement setup. A flow measurement device is installed in the tunnel downstream of the sampling plane. The positioning and dimensions of the different elements are indicative and are provided for illustration purposes; therefore, exact conformance with Figure 7.1. is not required.

There are several accepted configurations to lay out the air handling and control subsystems. All designs can use the same (not depicted) brake dynamometer, control software, data acquisition, and brake fixture. However, the testing facility shall ensure that all configurations include at least the subsystems and characteristics laid down in Table 7.1. Details regarding the

different elements of the setup are given in the corresponding paragraphs of this UN GTR as indicated in Table 7.1.

Table 7.1.

**Subsystems and characteristics required for the brake emissions testing setup as depicted in Figure 7.1.**

<i>Element</i>	<i>Subsystem</i>
1	Climatic conditioning unit with variable flow blower(s), air temperature, and air humidity control per paragraph 7.2.1.
2	Cooling air filtering medium per paragraph 7.2.2.1.
3	Cooling air temperature and humidity sensors placed upstream of the brake enclosure per paragraphs 7.2.1.1. and 7.2.1.2.
4	Brake enclosure per paragraph 7.4.
5	Brake assembly connected to the brake dynamometer per paragraph 8.4.1.
6	Brake dynamometer (not depicted but only denoted in grey) per paragraph 7.3.
7	Sampling tunnel per paragraph 7.5.
8	Sampling plane with the corresponding PM and PN sampling probes per paragraph 7.6.
9	Instruments to collect PM mass and measure PN concentrations per paragraphs 12.1. and 12.2., respectively
TPN10, SPN10	Systems to control, measure, and output signals of TPN10 and SPN10 per paragraph 12.2.
PM <sub>2.5</sub> , PM <sub>10</sub>	Systems to control sampling flow, sample brake particulate matter on filters, and output signals per paragraph 12.1.
10	Airflow measurement element placed downstream of the sampling plane per paragraph 7.2.3.
<i>Symbol</i>	<i>Characteristic</i>
L <sub>1</sub>	Minimum length of the straight duct upstream of the inlet of the brake enclosure per paragraph 7.4.2.
L <sub>2</sub>	Minimum length of the straight duct from the last disturbance upstream of the sampling plane to the sampling plane per paragraph 7.6.
L <sub>3</sub>	Minimum length of the straight duct from the sampling plane to the next disturbance downstream of the sampling plane per paragraph 7.6.
L <sub>4</sub>	Minimum length of the straight duct from the last disturbance upstream of the airflow measurement element to the airflow measurement element per paragraph 7.2.3.
L <sub>5</sub>	Minimum length of the straight duct from the airflow measurement element to the next disturbance downstream of the airflow measurement element per paragraph 7.2.3.
S <sub>Q</sub> , S <sub>P</sub> , S <sub>T</sub> , S <sub>RH</sub>	Output electronic signals for cooling airflow, pressure, temperature, and humidity per paragraphs 7.2.1. and 7.2.3.
d <sub>i</sub>	Reference duct's inner diameter. This is the same as the sampling tunnel's inner diameter
H <sub>s</sub> , H <sub>e</sub>	Points that define the beginning (H <sub>s</sub> ) and the end (H <sub>e</sub> ) of the mandatory horizontal and straight part in the layout (in the direction of the flow) per paragraph 7.4.2.

## 7.2. Climatic Conditioning Unit and Cooling Air

The conditioned cooling air a) provides clean and continuous cooling to the brake assembly and b) transports the aerosol from the enclosure into the

sampling tunnel and the PM/PN sampling probes. The cooling air needs to be under stable conditions for temperature and humidity in accordance with the specifications described in paragraph 7.2.1., clean with low background concentration values as defined in paragraph 7.2.2., and at a constant flow to ensure repeatable and reproducible testing conditions in accordance with the specifications described in paragraph 7.2.3.

The conditioned cooling air is supplied to the testing setup by the climatic conditioning unit. A typical system configuration may include cooling devices to cool and dehumidify the air, heating devices to increase the temperature of the air, and steam or water mist generators to increase the humidity in the air. Integral to the unit are the closed-loop proportional integral derivative controls, alarms, and sensors to monitor the condition of all devices and interfaces. The system shall consist of a variable flow blower able to supply the layout with conditioned cooling air over a wide range of airflows. The system shall be defined by its minimum and maximum operational flows. The following specifications apply for the minimum and maximum operational flows:

- (a) The minimum operational flow shall be defined in the range between 100-300 m<sup>3</sup>/h;
- (b) The maximum operational flow shall be at least 5 times the minimum operational flow;
- (c) The maximum operational flow shall be at least 1000 m<sup>3</sup>/h greater than the minimum operational flow.

The system may also combine two-variable flow blowers (one to push and one to pull) to provide a slight negative pressure inside the sampling tunnel. The climatic conditioning unit control shall be capable of providing the necessary interfaces to the operator and the dynamometer.

#### 7.2.1. Cooling Air Conditioning

The testing facility shall continuously monitor and control the temperature and humidity of the conditioned cooling air. For that reason, the testing facility shall install temperature and humidity sensors upstream of the brake enclosure. Positioning the sensors upstream of the brake enclosure avoids influencing the feedback signals with the thermal load from the brake events. Figure 7.1. provides an indicative position for the temperature and air humidity sensors (element 3).

The temperature sensor shall have an accuracy of  $\pm 1$  °C. The sensor applied for the measurement of absolute and relative humidity shall have an accuracy of  $\pm 5$  per cent of the nominal value (i.e. 50 per cent). The testing facility shall use the signals from these sensors to assess the stability of the cooling air's temperature and humidity. Table 7.2. summarises the requirements for the cooling air's temperature, humidity, and flow.

Table 7.2.

#### Summary of cooling air temperature, humidity, and flow requirements

<i>Parameter</i>	<i>Cooling air temperature</i>	<i>Cooling air relative humidity</i>	<i>Cooling airflow</i>
Nominal value	23 °C	50 %	Set value ( $Q_{set}$ ) per paragraph 10.
Average value: Maximum permissible tolerance	$\pm 2$ °C	$\pm 5$ %	$\pm 5$ % of $Q_{set}$
Instantaneous values (1Hz): Maximum permissible tolerance	$\pm 5$ °C	$\pm 30$ %	$\pm 5$ % of $Q_{set}$

<i>Parameter</i>	<i>Cooling air temperature</i>	<i>Cooling air relative humidity</i>	<i>Cooling airflow</i>
Instantaneous values (1Hz): Permissible deviation beyond the maximum permissible tolerance	Not defined	Not defined	±10 % of Q <sub>set</sub>
Instantaneous values (1Hz): Maximum time exceeding the maximum permissible tolerance	10 % of each test section's duration	10 % of each test section's duration	5 % of each test section's duration

#### 7.2.1.1. Cooling Air Temperature

Cooling air temperature at the measurement point shall be constant as defined below. The testing facility shall carry out the following steps:

- (a) Set the cooling air temperature to 23 °C. The average cooling air temperature shall not deviate more than ±2 °C of the set (nominal) value. Testing facilities shall aim for keeping the temperature as close as possible to the nominal value of 23 °C;
- (b) The average cooling air temperature requirements defined in point (a) of this paragraph apply to all sections of the brake emissions test including cooling air adjustment, bedding procedure, and emissions measurement (soaking sections not included);
- (c) Calculate and report the average cooling air temperature in all sections as defined in Table 13.6. in paragraph 13.4.;
- (d) The instantaneous cooling air temperature shall not deviate more than ±5 °C of the nominal value. If the instantaneous cooling air temperature deviates more than ±5 °C from the nominal value, the testing facility shall ensure that the provisions described in point (e) of this paragraph are met;
- (e) The instantaneous cooling air temperature may deviate more than ±5 °C of the nominal value ( $T < 18\text{ °C}$  or  $T > 28\text{ °C}$ ) for no longer than the 10 per cent duration of the test (soaking sections not included), provided that the average temperature meets the requirements defined in point (a) of this paragraph:
  - (i) The total number of instantaneous cooling air temperature readings (1Hz) with a value lower than 18 °C or higher than 28 °C shall be less than 527 during the cooling adjustment section;
  - (ii) The total number of instantaneous cooling air temperature readings (1Hz) with a value lower than 18 °C or higher than 28 °C shall be less than 1583 for each WLTP-Brake cycle of the bedding section;
  - (iii) The total number of instantaneous cooling air temperature readings (1Hz) with a value lower than 18 °C or higher than 28 °C shall be less than 1583 for the WLTP-Brake cycle of the emissions measurement section (soaking sections not included).
- (f) If the average or the instantaneous cooling air temperature falls out of the limits specified in this paragraph, the test shall be invalid.

#### 7.2.1.2. Cooling Air Humidity

Cooling air relative humidity shall be constant as defined below. The testing facility shall carry out the following steps:

- (a) Set the relative humidity of the cooling air to a nominal value of 50 per cent. The average cooling air humidity shall not deviate more than ±5 per cent of the nominal value. Testing facilities shall aim for keeping

the relative humidity as close as possible to the target value of 50 per cent;

- (b) The average cooling air relative humidity requirements defined in point (a) of this paragraph apply to all sections of the brake emissions test including cooling air adjustment, bedding procedure, and emissions measurement (soaking sections not included);
- (c) Calculate and report the average relative humidity of the cooling air in all sections as defined in Table 13.6. in paragraph 13.4.;
- (d) The instantaneous cooling air relative humidity shall not deviate more than  $\pm 30$  per cent of the nominal value. If the instantaneous cooling air relative humidity deviates more than  $\pm 30$  per cent from the nominal value, the testing facility shall ensure that the provisions described in point (e) of this paragraph are met;
- (e) The instantaneous cooling air relative humidity may deviate more than  $\pm 30$  per cent of the nominal value ( $RH < 20\%$  or  $RH > 80\%$ ) for no longer than 10 per cent of the duration of the test (soaking sections not included), provided that the average relative humidity meets the requirements defined in point (a) of this paragraph:
  - (i) The total number of instantaneous cooling air relative humidity readings (1Hz) with a value lower than 20 per cent RH or higher than 80 per cent RH shall be less than 527 during the cooling adjustment section;
  - (ii) The total number of instantaneous cooling air relative humidity readings (1Hz) with a value lower than 20 per cent RH or higher than 80 per cent RH shall be less than 1583 for each WLTP-Brake cycle of the bedding section;
  - (iii) The total number of instantaneous cooling air relative humidity readings (1Hz) with a value lower than 20 per cent RH or higher than 80 per cent RH shall be less than 1583 for the WLTP-Brake cycle of the emissions measurement section (soaking sections not included).
- (f) If the average or the instantaneous relative humidity falls out of the predefined limits specified in this paragraph, the test shall be invalid.

In addition to the specifications defined for the relative humidity, the testing facility shall ensure that the average absolute humidity of the cooling air is kept between 6 and 11 gH<sub>2</sub>O/kg dry air throughout the entire brake emissions test (soaking sections during emissions measurement are not included). If the average absolute humidity is outside of the limits specified in this paragraph, the test shall be invalid.

## 7.2.2. Cooling Air Cleaning

### 7.2.2.1. Cooling Air Filtering

The cooling air entering the test system shall pass through a medium capable of reducing particles of the most penetrating particle size in the filter material by at least 99.95 per cent or through a filter of at least class H13 as specified in EN 1822. Any other type of filter applied to remove volatile organic species (charcoal, activated carbon, or equivalent) shall be installed upstream of the H13 (or equivalent) filter. Figure 7.1. provides an indicative position for the air filtering device (element 2).

### 7.2.2.2. Particle Background Verification

The particle background in the overall layout shall be defined on a PN concentration basis. The testing facility shall measure the particle background

using the same instrumentation used for the PN emissions measurements. Details regarding the PN measurement system are provided in paragraph 12.2. The testing facility shall measure and report both TPN10 and SPN10 background concentrations at two levels: system-level and brake emissions test level.

#### 7.2.2.2.1. Particle Background Verification at the System Level

The first level concerns the system background verification upon the installation of the testbed setup, after any major maintenance, or when there are indications of a system malfunction. The testing facility shall apply the following steps for a complete background verification at the system level:

- (a) Perform the background verification with neither the brake fixture nor any brake components installed inside the brake enclosure;
- (b) Perform the background verification with the TPN10 and SPN10 measurement systems operating at the minimum calibrated PCRF setting;
- (c) Commence the background verification at least five minutes after the cooling airflow is stabilised to the average values per paragraph 7.2.3. for cooling airflow stability and to the average values per paragraph 7.2.1. for cooling air temperature and humidity;
- (d) Perform the background verification at two different cooling airflow settings. Apply the minimum and maximum operational flow of the system. The testing facility shall sample both TPN10 and SPN10 during the system background verification. The testing facility may use a single nozzle size for sampling TPN10 and SPN10 during the system background verification when applying different airflow settings;
- (e) The background verification procedure shall run for as long as it takes to allow the background concentration to stabilise. The background concentration is considered stable when the averaged over 5 minutes PCRF-corrected PN value is below the maximum permissible level per paragraph 7.2.2.2.3.

#### 7.2.2.2.2. Particle Background Verification at the Test Level

The second level concerns the background verification before and after the execution of a brake emissions test. The testing facility shall carry out the following steps for the pre-test verification:

- (a) Perform the regular background pre-test before the bedding section with the brake assembly mounted. The disc/drum shall not rotate and the pads/shoes shall not be disturbed. Do not apply braking during the background verification procedure (zero brake pressure);
- (b) Perform the pre-test verification with the cooling airflow setting defined for the given brake emissions test. The TPN10 and SPN10 measurement systems shall operate at the PCRF setting selected for the brake emissions test of the brake under testing;
- (c) Commence the background pre-test verification at least five minutes after the cooling airflow is stabilised to the average values per paragraph 7.2.3. for cooling airflow stability and to the average values per paragraph 7.2.1. for cooling air temperature and humidity;
- (d) Perform the background pre-test verification for as long as it takes for the background concentration to stabilise. The background concentration is considered stable when the PCRF-corrected PN value averaged over 5 minutes is below the maximum permissible level per paragraph 7.2.2.2.3.

The testing facility shall carry out the following steps for the post-test verification:

- (e) Perform the regular background post-test before purging and with the brake assembly mounted. The disc/drum shall not rotate and the pads/shoes shall not be disturbed. Do not apply braking during the background verification procedure (zero brake pressure);
- (f) Perform the post-test verification with the cooling airflow setting used for the given brake emissions test. The TPN10 and SPN10 measurement systems shall operate at the PCRf setting selected for the brake emissions test;
- (g) Commence the background post-test verification right after the emissions test and with the cooling airflow stabilised to the average values per paragraph 7.2.3. for cooling airflow stability and to the average values per paragraph 7.2.1. for cooling air temperature and humidity;
- (h) Perform the background post-test for as long as it takes for the background concentration to stabilise. The background concentration is considered stable when the PCRf-corrected PN value averaged over 5 minutes is below the maximum permissible level per paragraph 7.2.2.2.3.

#### 7.2.2.2.3. Calculation and Reporting of the Particle Background Concentration

The background shall be measured and reported at a TPN10 and SPN10 concentration basis at standard conditions. The testing facility shall apply the following procedure:

- (a) Perform a zero verification of the particle number counter (PNC). Apply a filter of appropriate performance at the inlet of the PNC per the equipment manufacturer's specification and record the PN concentration. The reading shall not exceed  $0.2 \text{ \#/cm}^3$  at the inlet of the PNC. Upon removal of the filter, the PNC shall show an increase in measured concentration and a return to  $\leq 0.2 \text{ \#/cm}^3$  on the replacement of the filter. The PN measurement device shall not report any errors;
- (b) Measure the average value of both TPN10 (TPN10<sub>b#</sub>) and SPN10 (SPN10<sub>b#</sub>) background concentrations at the system and test levels following paragraphs 7.2.2.2.1. and 7.2.2.2.2. Report the background values in normalised particle number concentration ( $\text{\#/Ncm}^3$ ) as specified in Table 13.6. in paragraph 13.4.;
- (c) The 5-minute average background concentration in the tunnel shall not exceed the maximum limit of  $20 \text{ \#/Ncm}^3$  for each TPN10 and SPN10. The limit of  $20 \text{ \#/Ncm}^3$  applies to the background concentration at both system and test levels as described in paragraphs 7.2.2.2.1. and 7.2.2.2.2.;
- (d) Failure to comply with the zero verification of the PNC described in point (a) and with the particle background limits defined in point (c) of this paragraph shall result in an invalid test;
- (e) The testing facility shall not subtract the background concentration values when reporting the TPN10 and SPN10 concentration values of the brake emissions measurement section per paragraph 12.2.4.;

#### 7.2.2.2.4. Calculation and Reporting of the Particle Background per Distance Driven

The testing facility shall also report the background expressed as the number of particles per distance driven to reflect the changes in the cooling air settings when testing different brakes. The calculation of the background per distance driven is determined by Equations 7.1 and 7.2:

$$\text{TPN10}_{\text{bEF}} = 10^6 \times \text{TPN10}_{\text{b\#}} \times NQ \div V_{\text{Set}} \quad (\text{Eq. 7.1})$$

$$\text{SPN10}_{\text{bEF}} = 10^6 \times \text{SPN10}_{\text{b\#}} \times NQ \div V_{\text{Set}} \quad (\text{Eq. 7.2})$$

Where:

$\text{TPN10}_{\text{bEF}}$  is the TPN10 background in the sampling tunnel in #/km;

$\text{SPN10}_{\text{bEF}}$  is the SPN10 background in the sampling tunnel in #/km;

$\text{TPN10}_{\text{b\#}}$  is the average normalised and PCRF-corrected TPN10 background concentration in the sampling tunnel in #/Nm<sup>3</sup>;

$\text{SPN10}_{\text{b\#}}$  is the average normalised and PCRF-corrected SPN10 background concentration in the sampling tunnel in #/Nm<sup>3</sup>;

$NQ$  is the average normalised airflow in the sampling tunnel in Nm<sup>3</sup>/h;

$V_{\text{Set}}$  is the average nominal linear speed of the WLTP-Brake cycle in km/h.

- (a) The PN background concentrations ( $\text{TPN10}_{\text{b\#}}$  and  $\text{SPN10}_{\text{b\#}}$ ) correspond to the average normalised and PCRF-corrected TPN10 and SPN10 values calculated throughout the background verification from the given parameters in the Time-Based file;
- (b) Calculate the normalised average cooling airflow ( $NQ$ ) during the background verification procedure from the given parameter in the Time-Based file;
- (c) The average nominal linear speed of the WLTP-Brake cycle equals to 43.7 km/h ( $V_{\text{set}} = 43.7$  km/h);
- (d) Calculate and report the background particle concentration values per distance driven only at the test level – both pre- and post-test – as specified in Table 13.6. in paragraph 13.4.

### 7.2.3. Cooling Airflow

The testing facility shall measure and report the cooling airflow throughout the entire brake emissions testing procedure. The measurement of the cooling airflow shall meet the following requirements:

- (a) The method of measuring cooling airflow shall be such that measurement is accurate to  $\pm 2$  per cent of the set value under all operating conditions;
- (b) Measure the cooling airflow downstream of the sampling plane. Figure 7.1. provides an indicative position for the flow measurement device (element 10);
- (c) For a single-point measurement, locate the flow measurement element at the centre of the duct, at least five duct diameters downstream and two duct diameters upstream of any flow disturbance. The flow measurement area may have a different inner diameter from the sampling tunnel. In such a case, duct diameter refers to the inner diameter of the duct where the flow element is located. The installation of the flowmeter shall not introduce significant pressure changes (i.e. the pressure at the flow measurement element shall be within  $\pm 1$  kPa from ambient pressure). The duct's inner diameter shall be at least 35 per cent of the sampling tunnel's inner diameter;
- (d) For a multi-point measurement, install the flow measurement element perpendicular to the flow direction, at least five duct diameters downstream and two duct diameters upstream of any flow disturbance. Duct diameter refers to the inner diameter of the duct where the flow



measurement elements are located. The specifications for the installation of the flowmeter defined in point (c) of this paragraph shall apply when the duct's inner diameter is different compared to the sampling tunnel's inner diameter;

- (e) Use a flow measurement device calibrated to report airflow at standard conditions. To ensure an appropriate conversion to operating conditions, the temperature sensor shall have an accuracy of  $\pm 1$  °C and the pressure measurements shall have a precision and accuracy of  $\pm 0.4$  kPa;
- (f) When the airflow measurement device is not calibrated to report values at standard conditions, ensure it includes a temperature sensor installed immediately before the measuring device. The temperature sensor shall fulfil the accuracy requirements described in point (e) of this paragraph. Use this measurement to normalise the airflow values;
- (g) When the airflow measurement device is not calibrated to report values at standard conditions, ensure it includes the measurement of the absolute pressure or the pressure difference from atmospheric pressure taken upstream from the measuring device. The pressure measurements shall fulfil the precision and accuracy requirements described in point (e) of this paragraph. Use this measurement to normalise the airflow values;
- (h) When using air filters to protect the airflow measurement device from contamination, install the filter at least five duct diameters upstream of the flow measurement device. Continuously monitor the pressure drop and, when necessary, correct the measured airflow accordingly. Follow the recommendations regarding the type and specifications of the protective filter provided by the manufacturer of the flow measurement device;

The testing facility shall ensure that the cooling airflow is constant throughout the entire brake emissions test as follows:

- (i) The set (nominal) value for the cooling airflow ( $Q_{set}$ ) shall be the same and constant during all sections of a brake emissions test. The same set value shall apply to cooling adjustment, bedding, and emissions measurement (including soaking) sections. This does not apply to the non-successful iterations of the cooling adjustment section which may have a different cooling airflow set value;
- (j) During the cooling adjustment section, the average measured cooling airflow shall be within  $\pm 5$  per cent of the set value defined at the beginning of the test;
- (k) During the bedding section, the average measured cooling airflow shall be within  $\pm 5$  per cent of the nominal value defined during the cooling adjustment section for the given brake;
- (l) During the emissions measurement section, the average measured cooling airflow shall be within  $\pm 5$  per cent of the nominal value defined during the cooling adjustment section for the given brake;
- (m) Calculate and report the time averaged measured cooling airflow in all sections as defined in Table 13.6. in paragraph 13.4.;
- (n) In case the average nominal or measured cooling airflow does not meet the requirements defined in this paragraph, the test shall be invalid;
- (o) The instantaneous cooling airflow can deviate more than  $\pm 5$  per cent and up to  $\pm 10$  per cent of the nominal value for no longer than 5 per cent of the duration of the cycle, provided that the average measured

cooling airflow meets the requirements defined in this paragraph. This applies to the cooling adjustment and emissions measurement sections:

- (i) For the cooling adjustment section, the instantaneous cooling airflow can deviate between  $\pm 5$  and  $\pm 10$  per cent of the set value for no longer than 264 s;
  - (ii) For the emissions measurement section, the instantaneous cooling airflow can deviate between  $\pm 5$  and  $\pm 10$  per cent of the set value for no longer than 792 s (soaking sections not included).
- (p) In addition to the compliance to the average and instantaneous limits defined in this paragraph, the cooling airflow in combination with the sampling airflow in the PM and PN sampling lines shall meet the isokinetic requirements per paragraphs 12.1.2.3. and 12.2.3.2., respectively;
- (q) A system leak check covering the ductwork and the enclosure shall be carried out before testing. Set the cooling airflow at the cooling setting defined for testing the given brake and measure for at least 2 min after the flow is stabilised. If the average measured flow is within  $\pm 5$  per cent of the set value proceed with the testing. If the flow fluctuates beyond  $\pm 5$  per cent of the set value cease testing activities, verify the flow measurement device, identify possible sources of the leak(s), take corrective action to resolve the issue, and resume testing by first performing a successful leak check. Alternative methods that follow the system manufacturer's specifications may be applied for determining the leakage rate of the system; however, the testing facility shall always report the actual level of flow fluctuation from the set value;
- (r) The testing facility shall report the cooling airflow in the Time-Based file of the brake emissions test as follows:
- (i) Report both the actual and normalised values as defined in Table 13.6. in paragraph 13.4.;
  - (ii) Calculate the corresponding instantaneous cooling airspeed at the sampling tunnel using the measured airflow and the sampling tunnel's inner diameter based on Equation 7.3;
  - (iii) Report the calculated cooling airspeed as defined in Table 13.6. in paragraph 13.4.

$$U = (4 \times 10^3 \times Q) / (\pi \times d_i^2) \quad (\text{Eq. 7.3})$$

Where:

$U$  is the cooling airspeed in km/h per Table 13.2.;

$Q$  is the measured cooling airflow in  $\text{m}^3/\text{h}$  per Table 13.2.;

$d_i$  is the sampling tunnel's inner diameter in mm per Table 7.1.

### 7.3. Brake Dynamometer and Automation Systems

The brake dynamometer is a technical system that provides the controlled kinetic energy to the brake under test. It primarily transforms rotational kinetic energy into thermal energy (Figure 7.2. – S1). Figure 7.2. provides a layout of the test system with the brake dynamometer and shows the interactions with the minimum subsystems required to execute a brake emissions test following this UN GTR.

Figure 7.2.

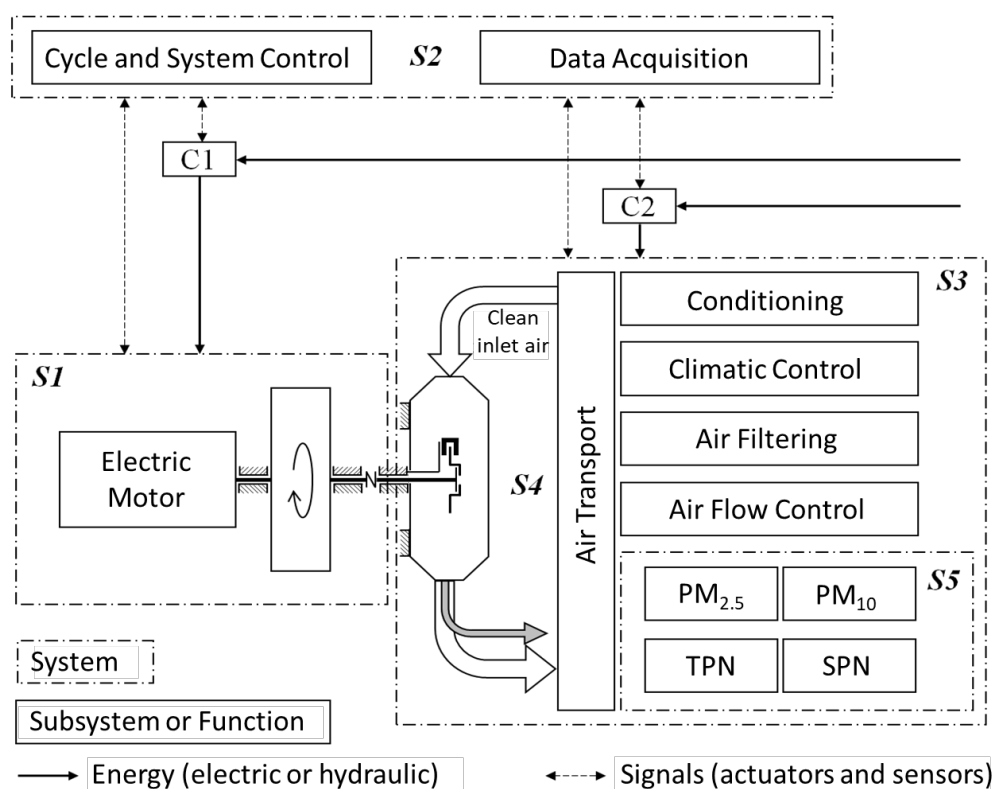
**Brake dynamometer and automation systems in the overall test layout**

Note: S1: Brake dynamometer, S2: Automation, control, and data acquisition system, S3: Climatic conditioning unit, S4: Brake enclosure and sampling plane, S5: Emissions measurement system. C1 and C2: Testing facility energy controls and monitoring system. The grey arrow represents the aerosol sample from the brake under testing

The brake dynamometer shall consist of at least the following elements:

- A variable-speed electric motor to accelerate or keep the rotational speed constant. It also modulates the test inertia in real driving conditions and simulates non-friction braking;
- A servo controller (hydraulic or electric) to actuate the brake under testing;
- A mechanical assembly to mount the brake under testing, allow free rotation of the disc or drum, and absorb the reaction forces from braking;
- A rigid structure to mount all the mandatory subsystems. The structure shall be capable of absorbing the forces and torque generated by the brake under testing;
- Sensors and devices to collect data and monitor the operation of the test system;

Integral to the test system is the automation, controls, and data acquisition system (Figure 7.2. – S2). It continuously controls the rotational speed of the motor as well as the operation and the interactions between the different systems (Figure 7.2. – S3, S4, S5). Subsystems S3, S4, and S5 are described in detail in paragraphs 7.2., 7.4.-7.5., and 12.1.-12.2., respectively. The different elements and subsystems in Figure 7.2. are indicative; therefore, exact conformance with the figure is not mandatory.

The automation, control, and data acquisition system performs all the functions that enable the brake emissions test. It accelerates the brake during acceleration events, maintains constant speed during cruise events, and modulates the

frictional torque during deceleration events to reduce the kinetic energy of the rotating masses. Additionally, the automation, control, and data acquisition system provide an interface to the operator, stores the data from the test, and handles the interfaces with other systems in the testing facility. The automation system shall be capable of using active torque control on the electric motor to increase or decrease the total effective test inertia during deceleration events. The electric motor shall also be capable of absorbing part of the kinetic energy equivalent to the road loads and the non-friction braking from the vehicle's powertrain. The software that operates the test system shall be capable of performing at least the following functions:

- (f) Execute the driving cycle automatically by operating all the closed-loop processes (mainly for brake controls, cooling air handling, and emissions measurements instruments);
- (g) Continuously sample and record data from all relevant sensors to generate the outputs defined in paragraph 13. of this UN GTR;
- (h) Monitor signals, messages, alarms, or emergency stops from the operator and the different systems connected to the test system.

#### 7.4. Brake Enclosure Design

The brake enclosure is the test chamber where the brake assembly is installed during brake emissions testing. It is a sealed chamber that prevents untreated air from entering and contaminating the air flowing around the brake assembly. The brake enclosure directs uniform conditioned air to cool the brake and transport aerosol into the sampling tunnel. Design requirements for the enclosure aim at providing general guidelines to ensure systems' comparability related to brake cooling and particle transport efficiency. Figure 7.1. provides an indicative position for the brake enclosure (element 4).

##### 7.4.1. General Elements

An indicative shape of the enclosure is illustrated in Figure 7.3. The enclosure is defined by one horizontal and four vertical planes. Plane A<sub>1</sub> represents the horizontal level aligned with the axis of the brake rotation and the axis of the inlet and outlet ducts. Plane A represents the vertical plane aligned with the enclosure's inlet. Plane B represents the vertical plane at the end of the transition from the inlet duct to the central section of the enclosure. Plane C shall be defined by the largest brake assembly applied on the vehicles that fall under the scope of this UN GTR or any brake with similar dimensions (i.e. diameter of 450 mm). Plane D represents the vertical plane aligned with the axis of the brake rotation.

Figure 7.3.

#### Indicative schematic representation of the brake enclosure

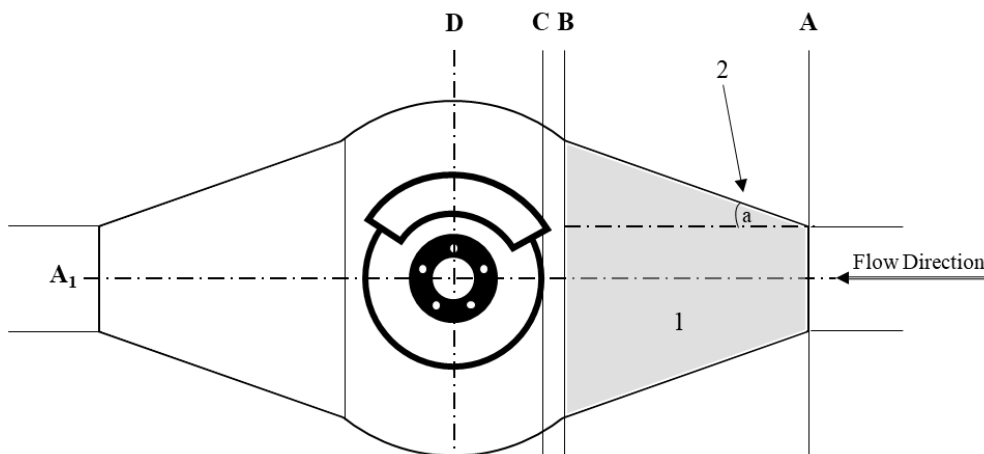

The inlet transition volume (Figure 7.3. – 1) is defined as the section of the enclosure between Planes A and B and is illustrated with a grey colour. The transition angle “a” (Figure 7.3. – 2) defines how smoothly the transition area develops in the enclosure. In Figure 7.3., the cooling air flows from right to left.

#### 7.4.2. Design Specifications

The following general specifications for the design of the brake enclosure and the verification of proper mixing and flow uniformity therein shall be met:

- (a) The brake enclosure shall have two conical or trapezoidal sections intersecting with a cylinder at the centre concentric to the axis of the brake rotation;
- (b) The transition from Plane A to Plane B shall be smooth and continuous with no abrupt changes. The requirements apply to the vertical plane, along the duct axis, and to the horizontal Plane A<sub>1</sub> along the enclosure’s cross section (intersecting cylinder);
- (c) The inlet and outlet cross-sections shall be designed to ensure smooth transition angles ( $15^\circ \leq a \leq 30^\circ$ ) in order to avoid sudden changes in cross-section shape or size;
- (d) The transition points between the segments shall not have any imperfections or features that may collect brake particles that could become airborne later during the test;
- (e) If fasteners are applied at the transition points, they shall not protrude into the enclosure area;
- (f) The cooling air shall enter and exit the enclosure only in the horizontal direction (i.e. the central axis of the enclosure defined by Plane A<sub>1</sub> shall align with the airflow direction). The tunnel shall be horizontal and straight for at least two duct diameters ( $2 \cdot d_i$ ) upstream of the enclosure’s inlet. The tunnel ducting shall also be horizontal after the enclosure at least until two duct diameters ( $2 \cdot d_i$ ) downstream of the sampling plane as specified in paragraph 7.5.;
- (g) The surfaces of the brake enclosure that come into contact with the aerosol shall have a seamless construction. Stainless steel with an electropolished finish (or equivalent) shall be used to attain an ultra-clean and ultra-fine surface and to enhance corrosion resistance;
- (h) Select all materials (including seals) to ensure sufficient protection against the media used (e.g. brake fluid) during setup. All enclosure gaps and interfaces shall be air-tight sealed using gasket linings or equivalent;
- (i) The airflow at the entrance of the enclosure shall remain turbulent with a Reynolds number of at least 4000 for all airflow testing settings to ensure sufficient mixing. Calculate the Reynolds number  $R_e$  for a given brake emissions test using Equation 7.4;

$$R_e = (U \times d_i) / (v \times 3.6 \times 1000) \quad (\text{Eq. 7.4})$$

Where:

$R_e$  is the Reynolds number for the given brake emissions test (unitless);

$U$  is the average cooling airspeed in km/h per Table 13.2.;

$d_i$  is the sampling tunnel diameter in mm per Table 7.1.;

$v$  is the kinematic viscosity of air (use a default value of  $1.48 \times 10^{-5}$  m<sup>2</sup>/s).

- (j) Plane C is tangential to an arbitrary disc of a diameter of 450 mm. Design the cross-section area at the enclosure inlet so that the airspeed at Plane C remains below the maximum permissible tolerance for speed uniformity defined in point (l) of this paragraph. If necessary, use flow straighteners or diffusion plates at the inlet's side upstream of Plane B to ensure the highest possible level of uniform flow at Plane C;
- (k) Calculate the airspeed values at nine positions in Plane C as defined in Figure 7.4. Divide Plane C into nine equal areas by lines parallel to the sides of the plane ( $l_1$  represents plane C's height –  $l_2$  represents plane C's axial depth). Point C5 shall be the centre of Plane C. The remaining 8 points shall be equally distributed around point C5 and placed in the middle of the imaginary lines between point C5 and the enclosure's walls at Plane C as demonstrated in Figure 7.4.;
- (l) Measure the airspeed values at the nine positions of Plane C without a brake assembly or a brake fixture installed. All the cooling air ducting utilized for the brake emissions test shall remain connected to the enclosure during these measurements. Carry out the measurement at the minimum and maximum operational flows of the test system. Let the flow stabilise for at least 2 minutes before conducting each measurement. The airflow is considered stabilized when the average measured flow in the sampling tunnel is within  $\pm 5$  per cent of the set value. Perform the airspeed measurement for at least 2 minutes after the stabilisation. The measurement time shall be of sufficient duration to detect any instability in the airspeed pattern that may affect the airspeed values. Airspeed at each position shall not vary by more than  $\pm 35$  per cent of the arithmetic mean of all measurements for a given flow.

Figure 7.4.  
Reference positions for airspeed verification

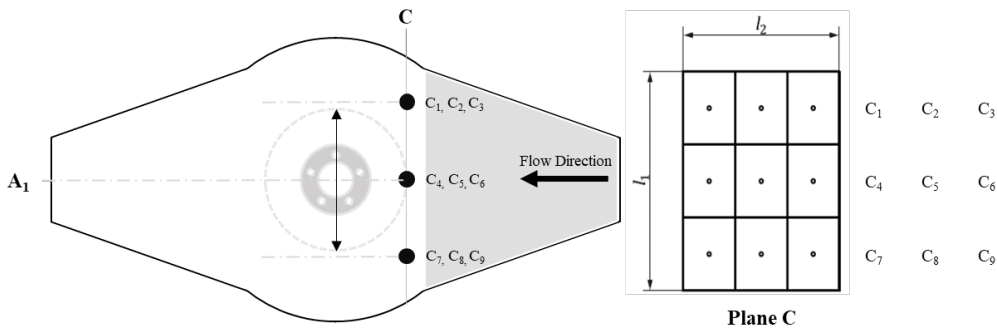

Note: Left-hand side – Verification of proper mixing and flow uniformity using Plane C for a disc with 450 mm outside diameter. Right-hand side – Distribution of measurement positions on Plane C (view in the direction of flow)

Cleaning and maintenance of the brake enclosure shall follow the specifications provided by the manufacturer regarding the frequency and means. The testing facility shall ensure that the enclosure is clean before commencing a brake emissions test.

7.4.3. Dimensions

The testing facility shall exercise due diligence to select the brake enclosure such that it fits the largest brake assembly applied to vehicles that fall within the scope of this UN GTR. This includes possible additional parts designed to reduce particle emissions (e.g. brake filtering devices) provided their dimensions fit the corresponding wheel dimensions on which the brake is mounted. In addition, the testing facility shall verify that the selection is within the capabilities for speed, brake test inertia, and brake torque expected during the test. Oversized brake enclosures may lead to low-pressure regions, low airspeeds to achieve the target brake temperatures, and longer particle transport

times. An indicative layout with the principal dimensions of the enclosure is illustrated in Figure 7.5.

Figure 7.5.

**Indicative schematic representation of the brake enclosure and its main dimensions**

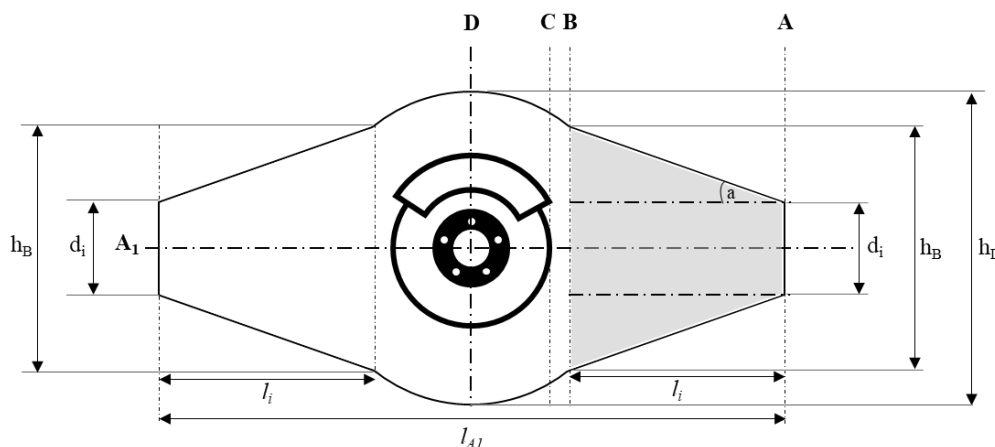

The minimum specifications related to the dimensions of the brake enclosure are described below. In addition to the dimension specifications described in this paragraph, the testing facility shall ensure the selected dimensions provide a design that meets all requirements defined in paragraph 7.4.2.

- (a) Design the brake enclosure symmetrically to Plane A<sub>1</sub>. The length of Plane A<sub>1</sub> ( $l_{A1}$ ) represents the most extended length of the enclosure along the flow direction. Plane A<sub>1</sub>'s length shall be between 1200 mm and 1400 mm ( $1200 \text{ mm} \leq l_{A1} \leq 1400 \text{ mm}$ );
- (b) Design the brake enclosure symmetrically to Plane D. The length of Plane D ( $h_D$ ) represents the longest distance (height) of the enclosure perpendicular to the flow direction. Plane D's height shall be between 600 mm and 750 mm ( $600 \text{ mm} \leq h_D \leq 750 \text{ mm}$ );
- (c) The distance from Plane C to Plane D is as long as the radius of the largest market available brake on vehicles within the scope of this UN GTR. Plane C's position in Figure 7.5. is given for illustration purposes and does not correspond to any actual dimension specification;
- (d) Design the height at Plane B ( $h_B$ ) such that the  $h_B/h_D$  ratio is always greater than 60 per cent ( $h_B/h_D > 60 \%$ ). Design the cross-section's transition depth at Plane B to equal the axial depth of the enclosure as defined in (g) of this paragraph;
- (e) Design the outlet's transition length ( $l_i$ ) and height ( $h_B$ ) such that they equate to the inlet's transition length ( $l_i$ ) and height ( $h_B$ );
- (f) The inlet and outlet diameters ( $d_i$ ) shall equal the diameter of the duct in the sampling tunnel as specified in paragraph 7.5.;
- (g) The maximum axial depth of the brake enclosure at Plane D (parallel to the brake rotation axis) shall be between 400 mm and 500 mm.

### 7.5. Design of the Sampling Tunnel

The sampling tunnel is defined as the part between the outlet of the brake enclosure and the inlet of the sampling probes. Figure 7.1. provides an indicative position for the sampling tunnel in the overall layout (element 7). There are two possibilities for the design of the sampling tunnel: a layout without a bend and a layout with one bend. The testing facility shall ensure the design of the sampling tunnel meets the following requirements:

- (a) The cooling air shall flow through round ducts with no variations in the cross-section between the enclosure exit and the sampling plane;
- (b) Stainless steel with an electropolished finish (or equivalent) shall be used for the surfaces of the tunnel that come into contact with the aerosol;
- (c) Any transition between adjacent sectors shall not have imperfections or features that may accumulate brake particulate matter. Whenever this is not feasible, ensure the transitions are engineered to minimise the accumulation of brake particulate matter;
- (d) Ducts shall have a constant inner diameter  $d_i$  of at least 175 mm and a maximum of 225 mm ( $175 \text{ mm} \leq d_i \leq 225 \text{ mm}$ ). The duct inner diameter  $d_i$  is defined as shown in Figure 7.6.;
- (e) A maximum of one bend of  $90^\circ$  or less may be applied in the sampling tunnel (i.e. downstream of the brake enclosure and upstream of the sampling plane) provided that the specifications described in (f) and (g) are met;
- (f) If a bend is applied in the sampling tunnel, the bending radius  $r_b$  shall be at least two times the duct inner diameter ( $2 \cdot d_i$ ). The bending radius is defined as shown in Figure 7.6.;

Figure 7.6.

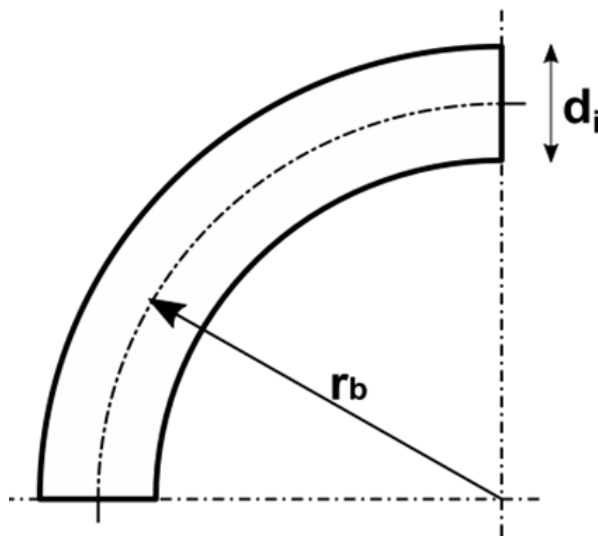
**Definition of duct diameter ( $d_i$ ) and bending radius ( $r_b$ )**

- (g) If a bend is applied in the sampling tunnel, a straight duct with a length of at least six times the duct diameter ( $6 \cdot d_i$ ) shall follow the bend before locating the sampling plane. Additionally, a straight duct with a length of at least two times the duct diameter ( $2 \cdot d_i$ ) shall follow the sampling plane before placing any flow disturbance (e.g. a second bend in the setup);
- (h) If there is no bend in the sampling tunnel, a straight duct with a length of at least six times the duct diameter ( $6 \cdot d_i$ ) shall follow the exit of the enclosure before locating the sampling plane. Additionally, a straight duct with a length of at least two times the duct diameter ( $2 \cdot d_i$ ) shall follow the sampling plane before placing any flow disturbance (e.g. a bend in the setup or a filter to protect the airflow measurement device from contamination);
- (i) The provisions for the ducts described in points (a), (c), and (d) of this paragraph shall apply at least to the tunnel ducting from two times the



duct inner diameter ( $2 \cdot d_i$ ) upstream of the enclosure's inlet to two times the duct inner diameter ( $2 \cdot d_i$ ) downstream of the sampling plane.

## 7.6. Sampling Plane

The sampling plane is the vertical plane in the sampling tunnel where the inlet of the sampling probes is placed. There are two possibilities for the design of the sampling plane: a layout with three sampling probes and a layout with four sampling probes. Figure 7.1. provides an indicative position for the sampling plane in the overall layout (element 8). The following provisions apply to the sampling plane:

- PM and PN sampling shall take place in the same cross-section area in the sampling tunnel. Reference paragraphs 12.1.1.1. and 12.2.1.1. for PM and PN sampling, respectively;
- Select a three-probe or four-probe configuration depending on the duct diameter as defined in points (e) and (f) of this paragraph. Figure 7.7. illustrates the proper positioning of the PM and PN sampling probes for both the three and four sampling probes layout;

Figure 7.7.

### Graphic representation of the spacing of the probes in the tunnel

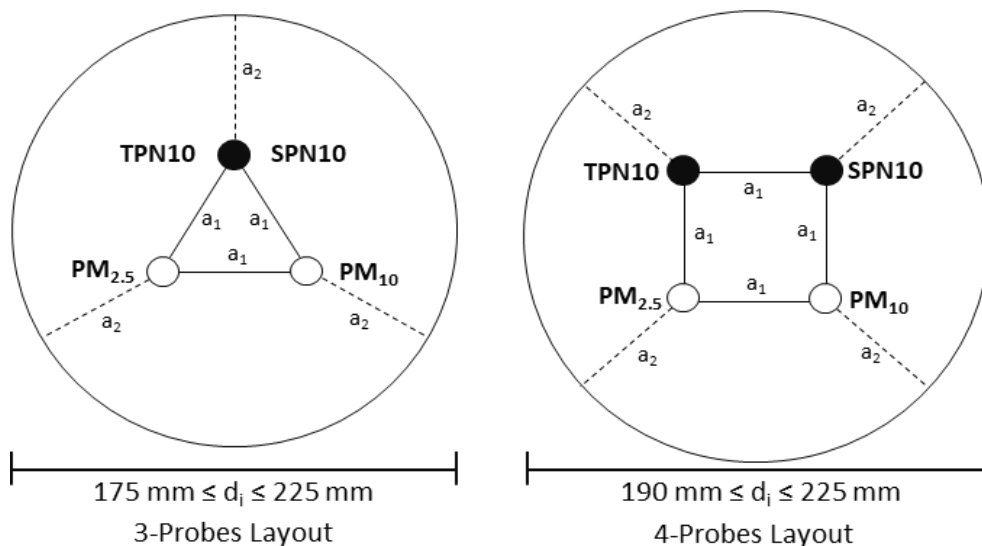

Note: View of the vertical part in the direction of the flow in the sampling tunnel that defines the sampling plane. White dots represent the PM sampling probes (PM<sub>2.5</sub>/PM<sub>10</sub>). Black dots represent the PN sampling probes (TPN10/SPN10)

- Place the sampling probes equally spaced around the central longitudinal axis of the sampling tunnel with a minimum distance between them of 47.5 mm (Figure 7.7. –  $a_1 \geq 47.5$  mm). Measure the distance using the outer diameter of the sampling probes;
- Place the sampling probes ensuring a minimum radial distance from the tunnel wall (probe-to-duct distance) of 47.5 mm (Figure 7.7. –  $a_2 \geq 47.5$  mm). Measure the probe-to-duct distance using the outer diameter of the sampling probes;
- The three-sampling probe setup requires a minimum duct diameter of 175 mm. The use of the three-probe setup is mandatory when the duct diameter is smaller than 190 mm ( $175 \text{ mm} \leq d_i < 190 \text{ mm}$ ). The three-probe setup may also be used when the duct diameter is bigger than 190 mm;
- The four-sampling probe setup requires a minimum duct diameter of 190 mm. The use of the four-probe setup is allowed only when the duct diameter is bigger or equal to 190 mm ( $190 \text{ mm} \leq d_i \leq 225 \text{ mm}$ ).

## 8. Test Preparation Requirements

### 8.1. Input Parameters

#### 8.1.1. Full-friction braking

The following parameters related to the brake – and the vehicle on which the brake under testing is mounted – shall be available to the testing facility to carry out full-friction braking emissions testing following this UN GTR.

Table 8.1.

**Required test parameters for full-friction braking**

No.	Parameters and Inputs	Short description	Symbol	Unit
1	Vehicle make and model	The vehicle make and model where the brake under testing is mounted		-
2	Vehicle axle	The axle on the vehicle, front or rear, where the brake under testing is mounted	FA or RA	-
3	Brake mounting position in the vehicle	The location of the brake under testing on the vehicle, right-hand corner or left-hand corner	RHC or LHC	-
4	Vehicle test mass	The vehicle mass to be simulated on the brake dynamometer as defined in point (a) in this paragraph	$M_{veh}$	kg
5	Brake force distribution	The ratio between the braking force of each axle and the total braking force on the vehicle as described in point (b) in this paragraph	FAF or RAF	%
6	Fixture style	The support fixture of the brake assembly per paragraph 8.4.1.	L0-U or L0-P	-
7	Part number for the disc or drum	The code labelled by the brake manufacturer on the disc/drum		-
8	Part number for the friction material	The code labelled by the friction manufacturer on the pads/shoes		-
9	Nominal Wheel Load	The load at the brake corner under testing (front or rear) before accounting for vehicle road loads or any other type of losses as defined in point (c) in this paragraph	$WL_{n-f}$ or $WL_{n-r}$	kg
10	Test (or applied) Wheel Load	Load at the brake corner under testing (front or rear) after accounting for vehicle road loads or any other type of losses as defined in point (d) in this paragraph	$WL_{t-f}$ or $WL_{t-r}$	kg
11	Tyre dynamic rolling radius	Tyre radius that equates to the revolutions per distance driven as published by the tyre manufacturer for the specific tyre size	$r_R$	mm
12	Brake Effective radius	The distance from the centre of the brake to the theoretical centre of the friction material as defined in point (e) in this paragraph	$r_{eff}$	mm
13	Brake nominal inertia	Wheel load with a gyration radius that equals the tyre dynamic rolling radius which imposes the same kinetic energy on the service brake as in the actual vehicle. It is defined in point (f) in this paragraph	$I_n$	$kg \cdot m^2$

14	Brake test (or applied) inertia	Nominal brake inertia after subtracting the decelerating forces induced by vehicle road loads or any other type of losses as defined in point (g) in this paragraph	$I_t$	$\text{kg}\cdot\text{m}^2$
15	Disc/Drum maximum outer diameter	The largest diameter of the disc or drum under testing	OD	mm
16	Disc Mass	Mass of the disc before testing – It is used for the allocation of the brake under testing to a nominal front wheel load to disc mass group as described in paragraph 10	DM	kg
17	Number of pistons per side	Number of pistons (or “pots”) on one side of the brake calliper		#
18	Piston Mean (or hydraulic) Diameter	The diameter of the piston of the brake under testing as defined in point (h) in this paragraph		mm
19	Disc calliper bolt tightening torque (if applicable)	Bolt tightening suggested torque if specified by the brake manufacturer		N·m
20	Brake calliper or brake drum efficiency (if applicable)	Efficiency to account for friction losses, piston travel, etc. if specified by the brake manufacturer. If not specified, use 100 per cent	$\eta$	%
21	Threshold pressure	Minimum pressure to overcome internal resistance before the onset of brake torque	$p_{\text{threshold}}$	kPa
22	Brake runout limit	The maximum movement allowed for the disc/drum along its axis/radius when installed on the brake fixture	BRO	$\mu\text{m}$

The following considerations shall be taken into account when calculating some of the required testing parameters provided in Table 8.1.:

- (a) Vehicle Test Mass ( $M_{\text{veh}}$ ) is the mass in running order (MRO) plus the mass of the optional fitted equipment of the vehicle (kg) on which the tested brake is mounted plus:
  - (i) 37.5 kg that corresponds to an additional mass of 0.5 passengers, for category 1-1 vehicles;
  - (ii) 25 kg plus 28 per cent of the Maximum Vehicle Load (MVL), for category 2 vehicles with a fully laden mass below 3500 kg.
- (b) Brake Force Distribution (FAF or RAF) represents the ratio between the braking force of each axle and the total braking force on the vehicle, respectively. FAF represents the share of the braking force applied to the front axle. RAF represents the braking force share applied to the rear axle. The brake force distribution is expressed as a percentage. The brake force distribution for each vehicle (FAF or RAF) is provided by the vehicle manufacturer. The brake force distribution per the default method on UN Regulation No. 90 for decelerations below 0.65 g shall be applied only whenever the vehicle manufacturer’s specific value is not available. This corresponds to:
  - (i) 77 per cent for the front axle and 32 per cent for the rear axle for category 1-1 vehicles;
  - (ii) 66 per cent for the front axle and 39 per cent for the rear axle for category 2 vehicles with a fully laden mass below 3500 kg.

- (c) Nominal Wheel Load ( $WL_n$ ) represents the load on the brake under testing (front or rear) before accounting for vehicle road loads or any other type of losses. It is a function of the vehicle test mass and the brake force distribution and is calculated from Equations 8.1a and 8.1b. The nominal wheel load is used to calculate the test wheel load. Additionally, it is used to classify the brake under testing into a nominal front wheel load to disc mass group according to its ( $WL_{n-f}/DM$ ) ratio when adjusting the cooling settings as specified in paragraph 10.

$$WL_{n-f} = 0.5 \times M_{veh} \times FAF \quad (\text{Eq. 8.1a})$$

$$WL_{n-r} = 0.5 \times M_{veh} \times RAF \quad (\text{Eq. 8.1b})$$

Where:

$WL_{n-f}$  is the nominal front wheel load in kg per Table 8.1.;

$WL_{n-r}$  is the nominal rear wheel load in kg per Table 8.1.;

$M_{veh}$  is the vehicle test mass in kg per Table 8.1.;

FAF is the front brake force distribution per Table 8.1.;

RAF is the rear brake force distribution per Table 8.1.

- (d) Test (or applied) Wheel Load ( $WL_t$ ) represents the load on the brake under testing (front or rear) after accounting for vehicle road loads or any other type of losses. It is a function of the nominal wheel load and is calculated from Equations 8.2a and 8.2b. The  $WL_t$  is reduced by 13 per cent compared to the  $WL_n$  to account for the road loads of the vehicle during real-world operation. The  $WL_t$  is applied during the entire brake emissions test including cooling adjustment, bedding, and emissions measurement sections.

$$WL_{t-f} = 0.87 \times WL_{n-f} \quad (\text{Eq. 8.2a})$$

$$WL_{t-r} = 0.87 \times WL_{n-r} \quad (\text{Eq. 8.2b})$$

- (e) Brake Effective Radius ( $r_{eff}$ ) is defined as the distance from the centre of the brake (disc or drum) to the theoretical centre of the friction material. A circle drawn with this radius would be placed at the centre of the disc-pads or drum-shoes contact surface. For disc brakes, the brake effective radius shall be provided by the brake manufacturer. For a drum brake, the effective radius is half of the drum's inner diameter.
- (f) Brake Nominal Inertia ( $I_n$ ) represents the wheel load with a radius of gyration equal to the tyre dynamic rolling radius which imposes the same kinetic energy on the service brake as in the actual vehicle. It is a function of the nominal wheel load and the tyre dynamic rolling radius and is calculated from Equation 8.3:

$$I_n = WL_n \times r_R^2 \quad (\text{Eq. 8.3})$$

Where:

$I_n$  is the brake nominal inertia in  $\text{kg} \cdot \text{m}^2$  per Table 8.1.;

$WL_n$  is the nominal wheel load in kg per Table 8.1.;

$r_R^2$  is the tyre dynamic rolling radius in m per Table 8.1.

- (g) Brake Test (or applied) Inertia ( $I_t$ ) represents the brake nominal inertia after subtracting the decelerating forces induced by vehicle road loads or any other type of losses. The brake test inertia is the primary source of kinetic energy during braking. It is a function of the brake nominal inertia and is calculated following Equation 8.4. The brake test inertia

is reduced by 13 per cent compared to the brake nominal inertia to account for the vehicle road load losses during real-world operation. The brake test inertia applies to the entire brake emissions test including cooling adjustment, bedding, and emissions measurement sections.

$$I_t = 0.87 \times I_n \quad (\text{Eq. 8.4})$$

- (h) Piston Mean (or hydraulic) Diameter ( $d_{\text{piston}}$ ) for drum brakes is the wheel cylinder piston diameter. The  $d_{\text{piston}}$  for the disc brakes represents the equivalent piston diameter of the brake under testing. If the calliper contains several (n) pistons, the testing facility shall determine the piston hydraulic diameter using the equivalent individual piston diameters acting on one side of the calliper with Equation 8.5:

$$d_{\text{piston}} = \sqrt{d_1^2 + d_2^2 + \dots + d_n^2} \quad (\text{Eq. 8.5})$$

#### 8.1.2. Non-Friction Braking

The following parameters related to the brake – and the brake emissions family parent – shall be available to the testing facility to carry out non-friction braking emissions testing in accordance with this UN GTR.

Table 8.2.

**Required test parameters for non-friction braking**

No.	Parameters and Inputs	Short description	Symbol	Unit
1	Vehicle make, model, and type	The brake emissions family parent make, model, and type (i.e. PEV, OVC-HEV, NOVC-HEV Cat.1, NOVC-HEV Cat.2, ICE) where the brake under testing is mounted		-
2	Vehicle axle	The axle on the brake emissions family parent vehicle, front or rear, where the brake under testing is mounted	FA or RA	-
3	Brake mounting position in the vehicle	The location of the brake under testing on the brake emissions family parent vehicle, right-hand corner or left-hand corner	RHC or LHC	-
4	Vehicle test mass	The brake emissions family parent vehicle mass to be simulated on the brake dynamometer as defined in point (a) in this paragraph	$M_{\text{veh}}$	kg
5	Brake force distribution	The ratio between the braking force of each axle and the total braking force on the brake emissions family parent vehicle as described in point (b) in this paragraph	FAF or RAF	%
6	Fixture style	The support fixture of the brake assembly per paragraph 8.4.1.	L0-U or L0-P	-
7	Part number for the disc or drum	The code labelled by the brake manufacturer on the disc/drum		-
8	Part number for the friction material	The code labelled by the friction manufacturer on the pads/shoes		-
9	Nominal Wheel Load	The load at the brake corner under testing (front or rear) before accounting for vehicle	$WL_{n-f}$ or $WL_{n-r}$	kg

		road loads or any other type of losses as defined in point (c) in this paragraph		
10	Test (or applied) Wheel Load	Load at the brake corner under testing (front or rear) after accounting for vehicle road loads or any other type of losses as defined in point (d) in this paragraph	WL <sub>L-f</sub> or WL <sub>L-r</sub>	kg
11	Tyre dynamic rolling radius	Tyre radius that equates to the revolutions per distance driven as published by the tyre manufacturer for the specific tyre size	r <sub>R</sub>	mm
12	Brake Effective radius	The distance from the centre of the brake to the theoretical centre of the friction material as defined in point (e) in this paragraph	r <sub>eff</sub>	mm
13	Brake nominal inertia	Wheel load with a gyration radius that equals the tyre dynamic rolling radius which imposes the same kinetic energy on the service brake as in the actual brake emissions family parent vehicle. It is defined in point (f) in this paragraph	I <sub>n</sub>	kg·m <sup>2</sup>
14	Brake test (or applied) inertia	Nominal brake inertia after subtracting the decelerating forces induced by vehicle road loads or any other type of losses as defined in point (g) in this paragraph	I <sub>t</sub>	kg·m <sup>2</sup>
15	Disc/Drum maximum outer diameter	The largest diameter of the disc or drum under testing	OD	mm
16	Disc Mass	Mass of the disc before testing – It is used for the allocation of the brake under testing to a nominal front wheel load to disc mass group as described in paragraph 10	DM	kg
17	Number of pistons per side	Number of pistons (or “pots”) on one side of the brake calliper		#
18	Piston Mean (or hydraulic) Diameter	The diameter of the piston of the brake under testing as defined in point (h) in paragraph 8.4.1.		mm
19	Disc calliper bolt tightening torque (if applicable)	Bolt tightening suggested torque if specified by the brake manufacturer		N·m
20	Brake calliper or brake drum efficiency (if applicable)	Efficiency to account for friction losses, piston travel, etc. if specified by the brake manufacturer. If not specified, use 100 per cent	η	%
21	Threshold pressure	Minimum pressure to overcome internal resistance before the onset of brake torque	p <sub>threshold</sub>	kPa
22	Brake runout limit	The maximum movement allowed for the disc/drum along its axis/radius when installed on the brake fixture	BRO	μm

The following considerations shall be taken into account when calculating some of the required testing parameters provided in Table 8.2.:

- (a) Vehicle Test Mass ( $M_{veh}$ ) is the mass in running order (MRO) of the brake emissions family parent vehicle plus the mass of the optional fitted equipment of the vehicle (kg) on which the tested brake is mounted plus:

- (i) 37.5 kg that corresponds to an additional mass of 0.5 passengers, for category 1-1 vehicles;
  - (ii) 25 kg plus 28 per cent of the Maximum Vehicle Load (MVL), for category 2 vehicles with a fully laden mass below 3500 kg.
- (b) Brake Force Distribution (FAF or RAF) represents the ratio between the braking force of each axle and the total braking force on the brake emissions family parent vehicle, respectively. The provisions described for FAF and RAF in paragraph 8.1.1. (b) apply.
  - (c) Nominal Wheel Load ( $WL_n$ ) represents the load on the brake under testing (front or rear) before accounting for vehicle road loads or any other type of losses. It is a function of the brake emissions family parent vehicle test mass and the brake force distribution and is calculated from Equations 8.1a and 8.1b.
  - (d) Test (or applied) Wheel Load ( $WL_t$ ) represents the load on the brake under testing (front or rear) after accounting for vehicle road loads or any other type of losses. It is a function of the nominal wheel load and is calculated from Equations 8.2a and 8.2b using the brake emissions family parent vehicle specific parameters.
  - (e) Brake Effective Radius ( $r_{eff}$ ) is defined as the distance from the centre of the brake (disc or drum) to the theoretical centre of the friction material. The provisions described for  $r_{eff}$  in paragraph 8.1.1. (e) apply.
  - (f) Brake Nominal Inertia ( $I_n$ ) represents the wheel load with a radius of gyration equal to the tyre dynamic rolling radius which imposes the same kinetic energy on the service brake as in the actual brake emissions family parent vehicle. It is calculated from Equation 8.3.
  - (g) Brake Test (or applied) Inertia ( $I_t$ ) represents the brake nominal inertia after subtracting the decelerating forces induced by vehicle road loads or any other type of losses. It is calculated following Equation 8.4.
  - (h) Piston Mean (or hydraulic) Diameter ( $d_{piston}$ ) as defined in paragraph 8.1.1. (h).

## 8.2. Test Setup Preparation

### 8.2.1. Full-Friction and Non-Friction Braking

The testing facility shall perform the following tasks before commencing a brake emissions test:

- (a) Verify the availability of all the test documentation, brake information, control program, dynamometer capabilities, and test conditions;
- (b) Update or upload the corresponding control program, test parameters and conditions, and brake information onto the brake dynamometer control system;
- (c) Install the brake assembly onto the test fixture and the dynamometer tailstock in accordance with the specifications described in paragraph 8.4.1. Connect with the adaptors to the main dynamometer shaft;
- (d) Install the brake pads or brake shoes and perform a thorough brake bleed to remove air bubbles from the brake lines spanning from the master cylinder up to the brake;
- (e) Perform a visual inspection of the brake under testing, brake fixture, thermocouple wires, and hydraulic brake lines to ensure proper routing and connections;
- (f) Measure the brake run out (BRO) by placing the dial gauge tip 10 mm outwards from the centreline of the disc outboard surface (disc brakes)

or by placing the dial gauge radially on the centreline of the inner surface of the drum (drum brakes). Brake pads or shoes shall not be mounted during this measurement. Verify that the BRO is less than 50  $\mu\text{m}$  while manually rotating the disc or drum installed on the dynamometer. If the BRO is above 50  $\mu\text{m}$ , adjustments to brake fixturing and/or inspection of the brake parts shall be made to reduce BRO to a value below 50  $\mu\text{m}$ . In case the BRO before the start of the test remains above the limit defined in this paragraph, the test shall be invalid;

- (g) Ensure all the instruments are available per the standard operating procedure defined by the instrument manufacturers on usage and cleaning. Ensure all filter media are available per the standard operating procedure defined by the filter manufacturer on filter conditioning, handling, and storage;
- (h) Perform brake static applies at brake pressures in the range of 3-30 bar to verify the fluid displacement curve for bleed check and visual inspection of any fluid leak inside the enclosure;
- (i) Close the brake enclosure, turn on the environmental conditioning system, and verify the operation of the cooling air system in accordance with the specifications defined in paragraph 7.2.;
- (j) Perform acceleration events to reach different linear speeds (5 km/h, 50 km/h, and 135 km/h) and record residual torque during the acceleration to the set speed and after cruising at the target speeds for 10 seconds (at zero brake pressure). An acceleration level of 1  $\text{m/s}^2$  for 5 km/h and 2  $\text{m/s}^2$  for the other two target speeds shall be applied. Verify that the spinning torque remains between 0 and 20  $\text{N}\cdot\text{m}$  (excluding the torque absorbed by the dynamometer bearings). If the spinning torque exceeds these values, repeat the procedure after checking again the BRO, running clearance (including thermocouples wiring), and brake bleed, in that order of diagnosis. In case the spinning torque for the brake under testing exceeds 20  $\text{N}\cdot\text{m}$ , the test shall be invalid;
- (k) Repeat the first brake event of the WLTP-Brake cycle ten times to verify data collection, test parameters, brake test inertia, and overall system operation;
- (l) When the cooling airflow for the axle and brake type under test is not known, adjust to a known value used for similar brakes as described in paragraph 10.2.4. Verify that the selected cooling airflow meets the specifications defined in paragraph 10. If not, adjust its value following the instructions in paragraph 10.2.4. until the nominal value is defined;
- (m) Verify the pre-test background emissions levels are within the acceptable limits as defined in paragraph 7.2.2.2.2. using the nominal cooling airflow;
- (n) Verify all instruments and devices for brake emissions measurements are enabled and running without any errors or warnings;
- (o) If no issues arise, continue with the bedding and emissions measurement sections following the procedures defined in paragraphs 11. and 12., respectively.

The steps defined in this paragraph apply when the testing facility carries out all brake emissions test sections with the same brake assembly. When the testing facility carries out the cooling adjustment section with a different brake assembly than the one used for testing, all steps in this paragraph except for points (g), (m), (n), and (o) shall apply for the cooling air adjustment section and all steps in this paragraph except for point (l) shall apply for the bedding and emissions measurement section.



### 8.3. Brake Temperature Measurement

The testing facility shall use embedded thermocouples for the measurement of the brake disc or drum temperature. The following specifications apply:

- (a) Use commercially available temperature sensors containing Nickel-chromium (Chromel) and Nickel-aluminum (Alumel) conductors (Type K thermocouples);
- (b) Use embedded thermocouples with a measurement temperature range between 0 °C and a minimum of 800 °C and a maximum permissible error (tolerance) of  $\pm 2.2$  °C or  $\pm 0.75$  per cent of the measured value;
- (c) Use embedded thermocouples with a solid tip readily installed to embed them onto the brake components;

Additionally, the following provisions for placing the embedded thermocouples onto the brake components apply:

- (d) Disc brakes: Locate the embedded thermocouple in the outboard plate rubbing surface – radially positioned 10 mm outwards of the centre of the friction path – and recessed ( $0.5 \pm 0.1$ ) mm deep below the surface of the disc. On vented discs, centre the thermocouple between two fins of the disc plate. Figure 8.1. illustrates the proper installation of embedded thermocouples on brake discs. The symbol 'X' denotes the surface contact radius of the disc and the pads;

Figure 8.1.

#### Schematic installation of embedded thermocouples for brake discs

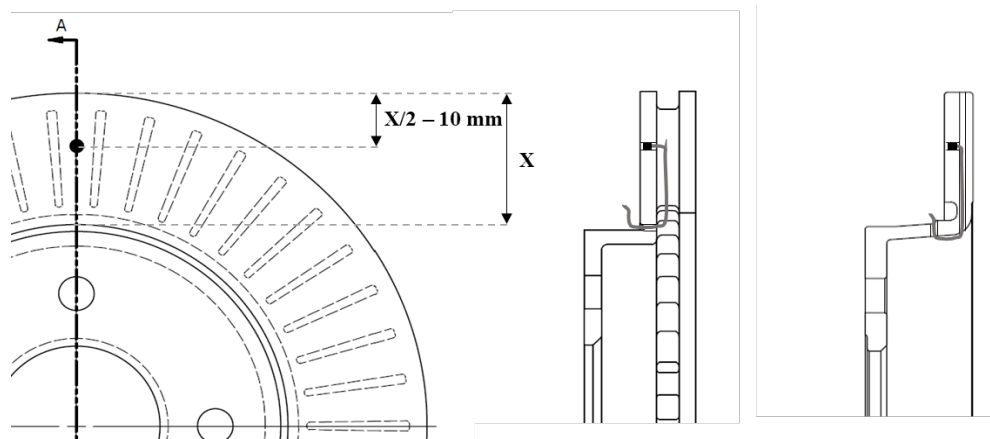

- (e) Drum brakes: Locate the embedded thermocouple at the centre of the friction path recessed ( $0.5 \pm 0.1$ ) mm below the inside surface of the brake drum. Figure 8.2. illustrates the proper installation of embedded thermocouples on brake drums;

Figure 8.2.

#### Schematic installation of embedded thermocouples for brake drums

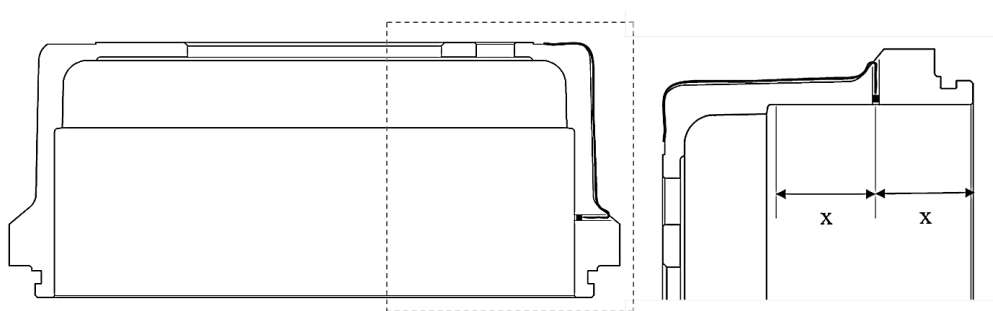

- (f) The installation of embedded or other types of thermocouples for measuring brake pad or shoe temperature during brake particle emissions tests in the context of this UN GTR is strongly discouraged.

Brake temperature shall be reported in the Time-Based file as described in Table 13.6. in paragraph 13.4. The testing facility shall use these thermocouple readings for reporting brake temperature during all testing sections. As an example, the testing facility shall use the temperature readings of the embedded thermocouples in the Time-Based file ( $T_{\text{brake}}$ ) to check the correct application of the initial temperature at the individual trips of the WLTP-Brake cycle in accordance with the specifications described in paragraph 9.2.

#### 8.4. Brake Positioning

##### 8.4.1. Brake Assembly

The installing position of the brake assembly defines the axis of rotation of the brake assembly and at the same time the location of Planes A<sub>1</sub> and D of the enclosure. The proper installation position is illustrated in Figure 8.3. with A<sub>1</sub> and D perpendicularly intersecting the axis of rotation.

Figure 8.3.

#### Installation position of the brake assembly and the calliper

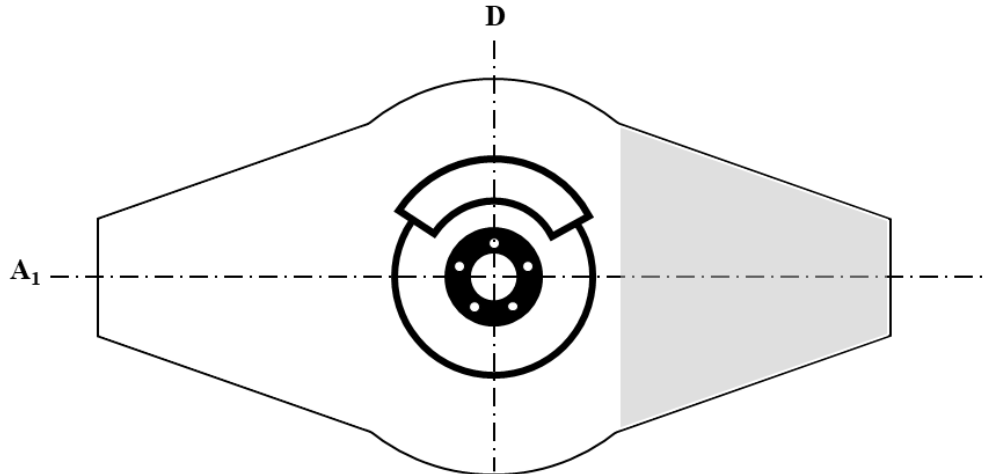

The testing facility shall use a suitable brake fixture to mount the brake assembly by connecting the tailstock (non-rotating side) to the brake dynamometer shaft (rotating side). The minimum subsystems of the dynamometer brake fixture shall include:

- Mounting components to attach the brake test fixture to the (non-rotating) tailstock;
- Structural components to transfer the braking torque and forces to the tailstock;
- Mounting components to take the brake calliper or the backing plate assembly for drum brakes;
- Rotating parts to mount the brake disc or brake drum onto;
- Rotating components to connect the shaft of the brake dynamometer to the brake disc or brake drum.

The support fixture of the brake assembly shall allow the brake to freely rotate by 360° with low friction and without exhibiting vibration or oscillations during testing. The testing facility shall mount the brake assembly on the dynamometer using a universal style (L0-U) or post-style (L0-P) brake fixture.

The L0-U allows for directly attaching the brake assembly onto the dynamometer driveshaft without a wheel hub. The L0-P allows for the installation of the specific vehicle's bearing. Figures 8.4. and 8.5. illustrate some examples of the fixture style schematics for disc and drum brakes, respectively.

Figure 8.4.

**Example of allowed fixture styles schematics for disc brakes**

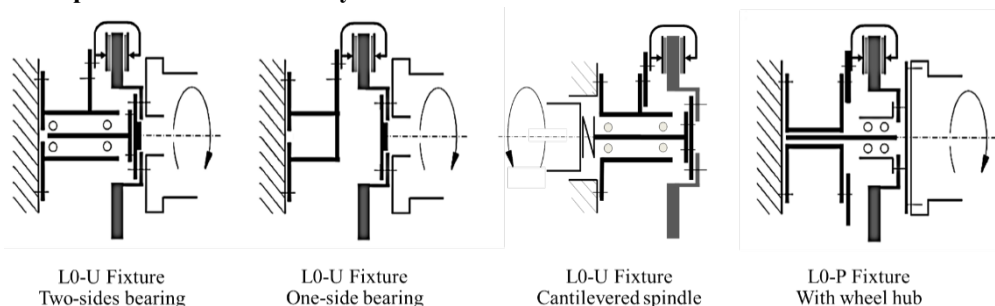
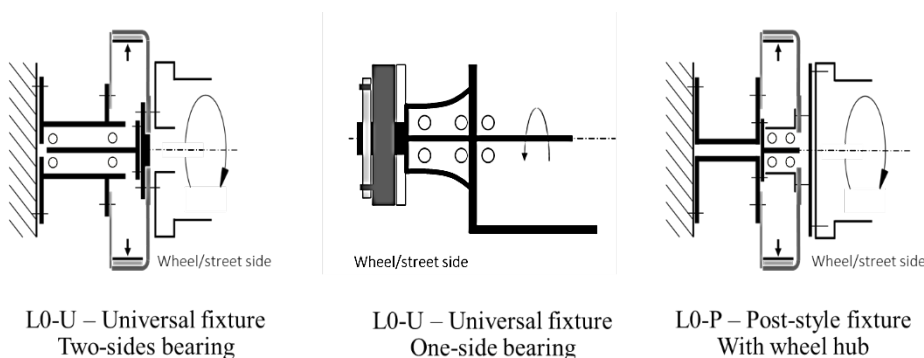

Figure 8.5.

**Example of allowed fixture styles schematics for drum brakes**



Any variant of these fixtures (one side bearing right or left or both sides bearing) may be applied provided they use an L0 style fixture as a reference (i.e. cylindrical and symmetrical base without additional extensions or protrusions different from those needed to mount the calliper assembly). For example, Figure 8.4. illustrates three different versions of an L0-U fixture: With two side bearings, one side bearing, and a cantilevered spindle. Unique brake mounting systems for braking technologies that the L0-U or the L0-P cannot accommodate may deviate from this requirement. In such a case, the testing facility shall submit the proper documentation demonstrating the need for their use.

The testing facility shall install the brake configuration (brake disc and calliper or drum assembly) such that it always rotates in the evacuation direction when driving forward as shown in Figure 8.6.

Figure 8.6.

**Schematic representation of disc rotation viewed from the wheel side (road side)**

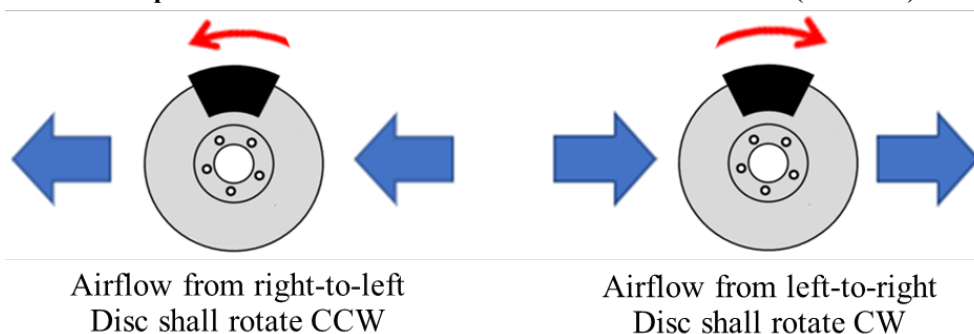

When the cooling air flows in a direction from right to left (Figure 8.6. left-hand side), the disc shall rotate in a counter-clockwise direction (CCW). When the cooling air flows in a direction from left to right (Figure 8.6. right-hand side), the disc shall rotate in a clockwise direction (CW). Alternative rotation directions are not allowed and will invalidate the test.

#### 8.4.2. Calliper Orientation

The testing facility shall position the calliper to minimise potential interference with the incoming cooling air. Install the calliper above the disc with the centre of the calliper in a 12-o'clock position as illustrated in Figure 8.6. irrespective of the mounting position at the vehicle. Other calliper orientations (e.g. vehicle's mounting position) or configurations are not allowed and shall invalidate the test. The parking brake shall be dismantled for carrying out a brake emissions test. Alternatively, a calliper without the parking brake feature shall be selected for the test.

## 9. WLTP-Brake Cycle

### 9.1. General Information

The testing cycle for all types of brakes shall be the time-based WLTP-Brake cycle. The WLTP-Brake cycle demands the continuous control of the equivalent linear speed on the brake dynamometer. Figure 9.1. illustrates the time-resolved speed trace of the WLTP-Brake cycle.

Figure 9.1.

#### Time-resolved vehicle speed for the WLTP-Brake cycle and classification of trip numbers

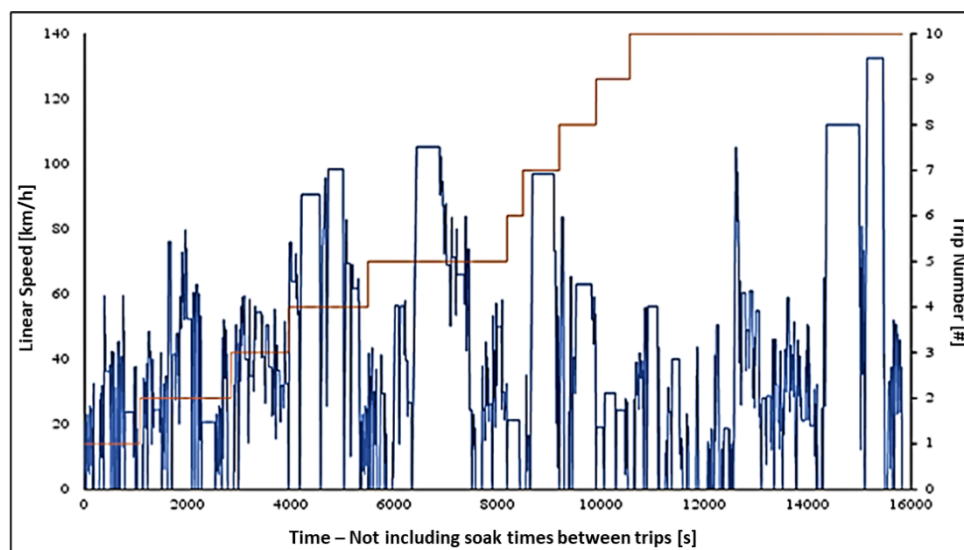

In summary, the WLTP-Brake cycle includes:

- Ten (10) individual trips (Trips #1 - #10) that represent different driving and braking conditions. The trips are separated by cooling sections. The trips' numbers are indicated on the right-hand side Y-axis in Figure 9.1.;
- 15 826 seconds of active speed control, without including the cooling sections between the individual trips of the cycle. The speed trace of the WLTP-Brake cycle is given in Annex A;
- 303 brake deceleration events. The main properties of each individual brake deceleration event are described in Annex B;

- (d) 192 km of total distance driven with an average speed of 43.7 km/h and a maximum speed of 132.5 km/h;
- (e) An average brake deceleration rate of 0.97 m/s<sup>2</sup>. A maximum brake deceleration rate of 2.18 m/s<sup>2</sup>;
- (f) An average brake deceleration duration of 5.7 s. A maximum brake deceleration duration of 15 s.

## 9.2. WLTP-Brake Cycle Application

### 9.2.1. Cooling Adjustment Section

The cooling air adjustment for testing different brakes shall be carried out using Trip #10 of the WLTP-Brake cycle as described in paragraph 10. of this UN GTR. Specific provisions related to the brake temperature at the beginning of Trip #10 apply to the cooling adjustment section. The testing facility shall perform the following steps:

- (a) Set the cooling airflow to the nominal value determined in paragraph 10;
- (b) Warm the brake to  $(40 \pm 1)$  °C following a sequence of brake events #1 to #7 of Trip #10 (brake events #190 to #196 when the entire WLTP-Brake cycle is considered) with a subsequent cooling phase down to  $(40 \pm 1)$  °C;
- (c) In case the target temperature cannot be reached with the application of the sequence described in (b), select one of the brake events #1 to #7 of Trip #10 and repeat it several times until the brake temperature reaches  $(40 \pm 1)$  °C;
- (d) Commence Trip #10 of the WLTP-Brake cycle at a brake temperature of  $(40 \pm 1)$  °C;
- (e) Run Trip #10 of the WLTP-Brake cycle without any interruption. Paragraph 9.3.1. describes the necessary actions in the case of interruptions.

Failure to comply with the described brake temperature provisions shall result in an invalid cooling adjustment. In such a case, the testing facility shall repeat the cooling adjustment section by applying a different airflow. The same brake parts are allowed to be used for repeating the cooling adjustment.

### 9.2.2. Bedding Section

The bedding procedure consists of five consecutive runs of the WLTP-Brake cycle as described in paragraph 11. Of this UN GTR. The correct execution of each WLTP-Brake cycle involves the performance of all ten trips in succession. Specific provisions related to the brake temperature at the beginning of each WLTP-Brake cycle apply to the bedding procedure. The testing facility shall carry out the following steps:

- (a) Set the cooling airflow to the nominal value for the brake under testing following the procedure described in paragraph 10.;
- (b) Commence the first run of the WLTP-Brake cycle at a brake temperature of  $(23 \pm 5)$  °C;
- (c) Do not apply soaking sections between the individual trips of the WLTP-Brake cycle during the bedding procedure;
- (d) Apply soaking sections between the five repetitions of the WLTP-Brake cycle. Commence each of the subsequent four WLTP-Brake cycles when the brake temperature reaches 40 °C;

- (e) If the brake temperature at the end of the previous WLTP-Brake cycle is between 30 °C and 40 °C, commence the subsequent WLTP-Brake cycle immediately without any intervention to warm the brake;
- (f) If the brake temperature at the end of the previous WLTP-Brake cycle is below 30 °C, discontinue the bedding section and identify discrepancies in the test execution or repeat the cooling adjustment. After fixing the issue, repeat the bedding section from the beginning;
- (g) Run the five individual WLTP-Brake cycles consecutively without any interruption. Paragraph 9.3.2. describes the necessary actions in the case of interruptions.

The minimum threshold temperature of 30 °C specified in this paragraph applies to all tested brakes. Failure to comply with the described brake temperature provisions shall result in an invalid bedding test and the testing facility shall repeat the bedding section. A new set of brake parts shall be used in the case of repeating the bedding procedure.

### 9.2.3. Emissions Measurement Section

The correct execution of the WLTP-Brake cycle involves the performance of all ten trips in succession. Soaking sections are mandatory between the individual trips of the WLTP-Brake cycle during the execution of the emissions measurement section. Specific provisions related to the brake temperature at the beginning of each trip of the WLTP-Brake cycle apply to the emissions measurement. The testing facility shall carry out the following steps:

- (a) Set the cooling airflow to the nominal value for the brake under testing following the procedure described in paragraph 10.;
- (b) Commence Trip #1 of the WLTP-Brake cycle at a brake temperature of  $(23 \pm 5)$  °C, without conducting any warm-up stops or snubs;
- (c) Apply soaking sections between the ten trips of the WLTP-Brake cycle. Commence each of Trips #2-10 as soon as the brake temperature reaches 40 °C;
- (d) For Trips #2-10, if the brake temperature at the end of the previous trip is between 30 °C and 40 °C, commence the subsequent trip immediately without any intervention to warm the brake disc;
- (e) For Trips #2-10, if the brake temperature at the end of the previous trip is below 30 °C, discontinue the emissions test and identify discrepancies in the test execution or repeat the cooling adjustment. After fixing the issue, repeat from the beginning of the bedding section using a new set of brake parts;
- (f) Run the WLTP-Brake cycle without any interruption. Paragraph 9.3.3. describes the necessary actions in the case of interruptions.

The minimum threshold temperature of 30 °C specified in this paragraph applies to all brakes. Failure to comply with the described brake temperature provisions shall result in an invalid emissions test.

## 9.3. WLTP-Brake Cycle Interruptions

### 9.3.1. Cooling Adjustment Section

If the test is interrupted (or the dynamometer faults) during the cooling adjustment section, the testing facility shall discontinue the test and restart the cooling adjustment procedure from the beginning. In such a case, after performing a data review and a visual inspection without disturbing the brake assembly, the testing facility shall use the same brake assembly to proceed with

the next iteration of Trip #10 and finalise the cooling adjustment section. If upon inspection there are reasons to compromise the test (loose components, brake fluid leakage, incorrect mounting, excessive vibration, etc.), the testing facility shall mount a new brake assembly and repeat the procedure in accordance with the specifications described in paragraph 8.2.1.

#### 9.3.2. Bedding Section

If the test is interrupted (or the dynamometer faults) during the bedding section, the testing facility shall continue bedding from the point of interruption considering the last recorded timestamp in the Time-Based file with non-zero values for the braking parameters. The testing facility shall not conduct any warm-up stops or snubs to reach 30 °C if the actual brake temperature is lower. The testing facility shall not disassemble the parts. If the brake parts are disassembled after the beginning of the bedding section, they are no longer suitable for completing bedding and the subsequent emissions measurement. In such a case, the testing facility shall replace them with new brake parts and repeat the bedding procedure from the beginning.

#### 9.3.3. Emissions Measurement Section

If the test is interrupted (or the dynamometer faults) during one or more soaking sections between two consecutive trips, the testing facility shall continue the test without disassembling the parts or conducting any warm-up stops or snubs provided that the interruption does not exceed 1h. In such a case, the testing facility shall deactivate the particle sampling pumps and the cooling air supply at the time of the interruption (auto-controls are strongly recommended for that purpose). The testing facility shall resume the function of the sampling pumps and the cooling air supply once the test is commenced again and after the cooling flow is stabilised in accordance with the specifications described in paragraph 7.2.3.

If the test is interrupted during Trips #1 through #10, the testing facility shall discontinue the emissions measurement section. The testing facility shall replace the used PM<sub>2.5</sub> and PM<sub>10</sub> filters with new ones and restart the emissions measurement from Trip #1 at an initial brake temperature of (23 ± 5) °C without disassembling the parts.

### 9.4. WLTP-Brake Cycle Quality Checks

The following quality checks shall be carried out to verify the correct execution of the WLTP-Brake cycle. A valid emissions test shall comply with all the criteria described below.

#### 9.4.1. Speed Violations Check

The speed violations quality check is necessary to ensure that the brake dynamometer has correctly executed the WLTP-Brake cycle speed trace. A speed violation occurs whenever the actual speed of the dynamometer is outside the speed trace tolerances defined by the prescribed (nominal) speed.

- (a) Upper-speed tolerance: 2.0 km/h higher than the nominal linear speed trace within ±1.0 second of the given point in time;
- (b) Lower-speed tolerance: 2.0 km/h lower than the nominal linear speed trace within ±1.0 second of the given point in time;

Figure 9.2. depicts the upper and lower speed tolerance limits as applied in the WLTP-Brake cycle.

Figure 9.2.  
Tolerance limits for speed violations during the WLTP-Brake cycle

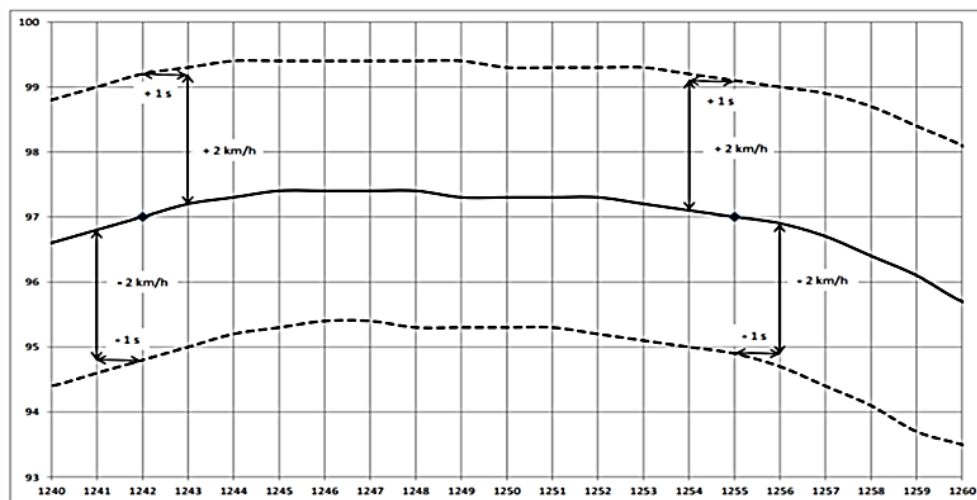

- (c) During the cooling adjustment section, the number of speed violations shall not exceed 158 for each complete Trip #10 of the WLTP-Brake cycle. This corresponds to 3 per cent of the Trip #10 duration;
- (d) During the bedding section, the number of speed violations shall not exceed 475 for each complete WLTP-Brake cycle. This corresponds to 3 per cent of the WLTP-Brake cycle duration and applies to all five repetitions of the WLTP-Brake cycle;
- (e) During the emissions measurement section, the number of speed violations shall not exceed 475 for each complete WLTP-Brake cycle. This corresponds to 3 per cent of the WLTP-Brake cycle duration. Soaking sections shall not be included in the calculation;
- (f) Calculate and report the number of speed violations in all sections as defined in Table 13.6. in paragraph 13.4. The computation of speed violations shall include all types of events (dwell, acceleration, cruising, and deceleration) but not soaking sections;
- (g) Failure to run Trip #10 of the WLTP-Brake cycle during the cooling adjustment section or the entire WLTP-Brake cycle during the bedding and emissions measurement sections within the speed tolerances defined in this paragraph shall result in an invalid brake emissions test.

#### 9.4.2. Number of Deceleration Events

This quality check examines the number of executed brake events. It is necessary to ensure that all 303 brake events of the WLTP-Brake cycle were applied during the emissions measurement section. A violation of this criterion occurs whenever the actual number of applied brake events is not equal to the nominal value (i.e. 303).

The testing facility shall verify the number of applied brake events as defined in Table 13.6. in paragraph 13.4. The parameters “Stop Duration” and “Deceleration Rate - Distance Averaged” shall be cross-checked and verified that both include 303 numerical and non-zero values that correspond to the respective 303 brake events of the WLTP-Brake cycle.

This quality check applies only to the emissions measurement section. Failure to perform the 303 brake events of the WLTP-Brake cycle during the emissions measurement section as defined in this paragraph shall result in an invalid test.



### 9.4.3. Kinetic Energy Dissipation

The kinetic energy dissipation quality check is necessary to ensure the application of the correct amount of specific friction work ( $W_f$ ) during the execution of the WLTP-Brake cycle. It is also an additional quality check that other input parameters (e.g. brake test inertia) have been calculated and applied correctly. This quality check applies to all brakes equipped on vehicles within the scope of this UN GTR. The parameters of the brake emissions family parent vehicle shall be used for the calculations when testing non-friction braking.

A violation of the kinetic energy dissipation quality check occurs whenever the sum of the calculated specific friction work of all brake events throughout Trip #10 of the WLTP-Brake cycle (for the cooling adjustment section) and the entire WLTP-Brake cycle (for the bedding or emissions measurement sections) is outside the defined tolerances:

- (a) Trip #10 upper specific friction work tolerance: 278 J/kg higher than the nominal specific friction work value of 5555 J/kg. Thus, the upper specific friction work tolerance is 5833 J/kg;
- (b) Trip #10 lower specific friction work tolerance: 278 J/kg lower than the nominal specific friction work value of 5555 J/kg. Thus, the lower specific friction work tolerance is 5277 J/kg;
- (c) WLTP-Brake cycle upper specific friction work tolerance: 799 J/kg higher than the nominal specific friction work value of 15983 J/kg. Thus, the upper specific friction work tolerance is 16782 J/kg;
- (d) WLTP-Brake cycle lower specific friction work tolerance: 799 J/kg lower than the nominal specific friction work value of 15983 J/kg. Thus, the lower specific friction work tolerance is 15184 J/kg;
- (e) During the cooling adjustment section, the calculated specific friction work over Trip #10 shall be between 5277 J/kg and 5833 J/kg. This corresponds to  $\pm 5$  per cent of the nominal value;
- (f) During the bedding section, the calculated specific friction work over the WLTP-Brake cycle shall be between 15184 J/kg and 16782 J/kg. This corresponds to  $\pm 5$  per cent of the nominal value and applies to all five repetitions of the WLTP-Brake cycle;
- (g) During the emissions measurement section, the calculated specific friction work over the WLTP-Brake cycle shall be between 15184 J/kg and 16782 J/kg. This corresponds to  $\pm 5$  per cent of the nominal value. Soaking sections shall not be included in the calculation;
- (h) The testing facility shall calculate the specific friction work by applying the integrals for torque and angular speed over time for each brake event using the submitted Event-Based file of the brake emissions test as defined in Table 13.6. in paragraph 13.4. The calculation requires also the use of the test wheel load ( $WL_t$ ) and follows Equation 9.1:

$$W_f = (2 \times \pi / 60) \times f \times \tau_{\text{brake}} \times t_{\text{brake}} / WL_t \quad (\text{Eq. 9.1})$$

Where:

- $W_f$  is the specific friction work in J/kg;
- $f$  is the rotational speed in rpm per Table 13.1.;
- $\tau_{\text{brake}}$  is the brake torque in Nm per Table 13.1.;
- $t_{\text{brake}}$  is the stop duration in sec per Table 13.1.;
- $WL_t$  is the test (or applied) wheel load in kg per Table 8.1.

- (i) Equation 9.1 provides the specific friction work for each one of the 114 and 303 brake events of Trip #10 and the WLTP-Brake cycle,

respectively. The testing facility shall calculate the total specific friction work by summing the calculated specific friction work from the individual brake events. The total specific friction work shall be compared to the prescribed (nominal) specific friction work value as described in points (a)-(c) of this paragraph;

- (j) Failure to complete any of the sections of the brake emissions test with a total specific friction work within the tolerances defined in this paragraph shall result in an invalid test.

## 10. Cooling Airflow Adjustment

Different test systems can embody different combinations of brake enclosure design and size, airflow or airspeed levels, and duct system layout and geometry. This paragraph establishes the proper methodology to adjust the airstream speed to provide comparable brake thermal regimes across the testing facilities.

### 10.1. Method Description

#### 10.1.1. Definition of Brake Assembly Groups and Verification Parameters

To determine the appropriate cooling airflow for the brake under testing, the testing facility shall first classify the brake into a nominal front wheel load ( $WL_{n-f}$ ) to disc or drum (in case a drum is used as a front brake) mass (DM) group according to its ( $WL_{n-f}/DM$ ) ratio.

The  $WL_{n-f}/DM$  ratio is calculated by dividing the  $WL_{n-f}$  (kg) by the pre-test disc or drum (in case a drum is used as a front brake) mass (kg). The testing facility shall determine the  $WL_{n-f}$  following the specifications described in paragraph 8.1.1. (c) for full-friction braking or paragraph 8.1.2. (c) for non-friction braking.

Four different groups are defined based on the  $WL_{n-f}/DM$  ratio: Group 1 with  $WL_{n-f}/DM \leq 45$ ; Group 2 with  $45 < WL_{n-f}/DM \leq 65$ ; Group 3 with  $65 < WL_{n-f}/DM \leq 85$ ; Group 4 with  $WL_{n-f}/DM > 85$ .

The testing facility shall apply the test wheel load ( $WL_t$ ) described in paragraph 8.1.1. (d) for full-friction braking or paragraph 8.1.2. (d) for non-friction braking – and not the nominal wheel load ( $WL_n$ ) – during the execution of all sections of the brake emissions test.

Three check parameters have been defined for the cooling air adjustment of the brake under testing. The target values and allowed tolerances for these parameters differ for each  $WL_{n-f}/DM$  group. The testing facility shall use the following parameters as a reference against which the cooling adjustment test results shall be compared:

- (a) Average brake temperature over Trip #10 of the WLTP-Brake cycle (ABT);
- (b) Average initial brake temperature of six selected brake events from Trip #10 of the WLTP-Brake cycle (IBT);
- (c) Average final brake temperature of six selected brake events from Trip #10 of the WLTP-Brake cycle (FBT).

The brake events referred to (b) and (c) of this paragraph are #46, #101, #102, #103, #104, and #106 of Trip #10. The details of the target brake events are specified in Table 10.1. When the entire WLTP-Brake cycle is considered, the brake events' corresponding sequence numbers are #235, #290, #291, #292, #293, and #295.

Table 10.1.  
**Specific brake events from Trip #10 of the WLTP-Brake cycle**

Parameter	Unit	Deceleration event					
		#46	#101	#102	#103	#104	#106
Start time	s	2088	4438	4459	4494	4522	4903
End time	s	2092	4447	4467	4503	4529	4918
Brake duration	s	4.0	9.0	8.0	9.0	7.0	15.0
Initial speed	km/h	97.4	112.0	68.2	80.9	73.4	132.5
Final speed	km/h	82.7	56.1	12.0	35.3	39.3	34.0

#### 10.1.2 Verification of Parameters and Tolerances for Brake Temperature

The target values and the corresponding tolerances for the three check parameters are given in Table 10.2.

Table 10.2.  
**Default temperature metrics and tolerances for brakes during Trip #10 of the WLTP-Brake cycle**

Group	ABT [ $A_1$ ]	IBT [ $A_2$ ] $\pm$ Tolerance	FBT [ $A_3$ ] $\pm$ Tolerance
$WL_{n-f}/DM \leq 45$	$\geq 50$ °C	$65 \pm 25$ °C	$95 \pm 35$ °C
$45 < WL_{n-f}/DM \leq 65$	$\geq 55$ °C	$75 \pm 25$ °C	$115 \pm 35$ °C
$65 < WL_{n-f}/DM \leq 85$	$\geq 60$ °C	$85 \pm 25$ °C	$130 \pm 35$ °C
$WL_{n-f}/DM > 85$	$\geq 65$ °C	$95 \pm 25$ °C	$150 \pm 35$ °C

- (a) The target values and the corresponding tolerances for the three check parameters apply to all types of front brakes mounted in all types of vehicles within the scope of this UN GTR;
- (b) For rear disc brakes, the nominal (or set) cooling airflow defined for the corresponding front brake application (i.e. same vehicle data) shall be applied. In this case, the allocation of the brake in a  $WL_{n-f}/DM$  category described in paragraph 10.1.1. shall be carried out using the front brake data;
- (c) For rear drum brakes, the nominal (or set) cooling airflow defined for the corresponding front brake application (i.e. same vehicle data) shall be applied. In this case, the allocation of the brake in a  $WL_{n-f}/DM$  category described in paragraph 10.1.1. shall be carried out using the front brake data.

#### 10.1.3. Computation of Verification Parameters and Acceptance Criteria

Once the brake is classified to its  $WL_{n-f}/DM$  Group per paragraph 10.1.1., the testing facility shall run Trip #10 of the WLTP-Brake cycle with new brake parts to obtain the values of the check parameters to populate the cells in Table 10.3. The testing facility shall apply the  $WL_{t-f}$  as defined in paragraph 8.1.1. (d) for full-friction braking or paragraph 8.1.2. (d) for non-friction braking to conduct the cooling air adjustment according to paragraph 10.1.4. The measured values for the check parameters shall be calculated using the produced test report files as follows:

- (a) Average brake temperature over Trip #10 of the WLTP-Brake cycle (ABT):

- (i) The target value ( $A_1$ ) depends on the  $WL_{n-f}/DM$  Group and is defined in Table 10.2.;
  - (ii) The measured value ( $B_1$ ) is calculated from the Time-Based file of the brake emissions test as defined in Table 13.6. in paragraph 13.4.;
  - (iii)  $B_1$  equals the average of all brake temperature entries corresponding to the entire duration of Trip #10 (5272 s).
- (b) Average initial brake temperature of selected brake events from Trip #10 of the WLTP-Brake cycle (IBT):
- (i) The target value ( $A_2$ ) and tolerances depend on the  $WL_{n-f}/DM$  Group and are defined in Table 10.2.;
  - (ii) The measured value ( $B_2$ ) is calculated from the Event-Based file of the brake emissions test as defined in Table 13.6. in paragraph 13.4.;
  - (iii)  $B_2$  equals the average temperature value of the individual IBT values recorded for each of the six selected brake events described in Table 10.1. The testing facility shall calculate  $B_2$  following Equation 10.1.

$$B_2 = (Y_1 + Y_2 + Y_3 + Y_4 + Y_5 + Y_6)/6 \quad (\text{Eq. 10.1})$$

Where:

$B_2$  is the average IBT of selected brake events from Trip #10 of the WLTP-Brake cycle in °C;

$Y_1$  is the IBT of brake event #46 from Trip #10 of the WLTP-Brake cycle in °C;

$Y_2$  is the IBT of brake event #101 from Trip #10 of the WLTP-Brake cycle in °C;

$Y_3$  is the IBT of brake event #102 from Trip #10 of the WLTP-Brake cycle in °C;

$Y_4$  is the IBT of brake event #103 from Trip #10 of the WLTP-Brake cycle in °C;

$Y_5$  is the IBT of brake event #104 from Trip #10 of the WLTP-Brake cycle in °C;

$Y_6$  is the IBT of brake event #106 from Trip #10 of the WLTP-Brake cycle in °C.

- (c) Average final brake temperature of selected brake events from Trip #10 of the WLTP-Brake cycle (FBT):
- (i) The target value ( $A_3$ ) and tolerances depend on the  $WL_{n-f}/DM$  Group and are defined in Table 10.2.;
  - (ii) The measured value ( $B_3$ ) is calculated from the Event-Based file of the brake emissions test as defined in Table 13.6. in paragraph 13.4.;
  - (iii)  $B_3$  equals the average temperature value of the individual FBT values recorded for each of the six selected brake events described in Table 10.1. The testing facility shall calculate  $B_3$  following Equation 10.2.

$$B_3 = (Z_1 + Z_2 + Z_3 + Z_4 + Z_5 + Z_6)/6 \quad (\text{Eq. 10.2})$$

Where:

- $B_3$  is the average FBT of selected brake events from Trip #10 of the WLTP-Brake cycle in °C;
- $Z_1$  is the FBT of brake event #46 from Trip #10 of the WLTP-Brake cycle in °C;
- $Z_2$  is the FBT of brake event #101 from Trip #10 of the WLTP-Brake cycle in °C;
- $Z_3$  is the FBT of brake event #102 from Trip #10 of the WLTP-Brake cycle in °C;
- $Z_4$  is the FBT of brake event #103 from Trip #10 of the WLTP-Brake cycle in °C;
- $Z_5$  is the FBT of brake event #104 from Trip #10 of the WLTP-Brake cycle in °C;
- $Z_6$  is the FBT of brake event #106 from Trip #10 of the WLTP-Brake cycle in °C.

After the execution of the cooling adjustment test with the selected air flow, the testing facility shall compare the recorded temperature values of the check parameters to the corresponding target values defined in Table 10.2. The difference between the target and test results for the check temperature parameters shall be calculated following Equations 10.3, 10.4, and 10.5:

$$C_1 = B_1 - A_1 \quad (\text{Eq. 10.3})$$

Where:

- $C_1$  is the difference in average brake temperatures over Trip #10 of the WLTP-Brake cycle in °C;
- $B_1$  is the measured ABT over Trip #10 of the WLTP-Brake cycle in °C;
- $A_1$  is the target ABT over Trip #10 of the WLTP-Brake cycle in °C per Table 10.2.

$$C_2 = |B_2 - A_2| \quad (\text{Eq. 10.4})$$

Where:

- $C_2$  is the absolute difference in average IBT of the selected events in °C;
- $B_2$  is the average IBT of selected brake events from Trip #10 of the WLTP-Brake cycle in °C;
- $A_2$  is the target IBT of the selected Trip #10 brake events in °C per Table 10.2.

$$C_3 = |B_3 - A_3| \quad (\text{Eq. 10.5})$$

Where:

- $C_3$  is the absolute difference in average FBT of the selected events in °C;
- $B_3$  is the average FBT of selected brake events from Trip #10 of the WLTP-Brake cycle in °C;
- $A_3$  is the target FBT of the selected Trip #10 brake events in °C per Table 10.2.

The testing facility shall compare the obtained results with the acceptance criteria as shown in Table 10.3.

Table 10.3.

**Calculation of brake temperature metrics [°C] and acceptance criteria during Trip #10**

<i>Trip #10 Event</i>	<i>Metric</i>	<i>Target Temperature</i>	<i>Cooling Adjustment Test Temperature</i>	<i>Difference</i>	<i>Acceptance Criteria</i>
–	<i>ABT</i>	$A_1$	$B_1$	$C_1$ per Equation 10.3	$C_1 \geq 0$ °C
–	<i>Average IBT</i>	$A_2$	$B_2$ per Equation 10.1	$C_2$ per Equation 10.4	$C_2 \leq 25$ °C
#46			$Y_1$	N/A	N/A
#101			$Y_2$		
#102			$Y_3$		
#103			$Y_4$		
#104			$Y_5$		
#106			$Y_6$		
–	<i>Average FBT</i>	$A_3$	$B_3$ per Equation 10.2	$C_3$ per Equation 10.5	$C_3 \leq 35$ °C
#46			$Z_1$	N/A	N/A
#101			$Z_2$		
#102			$Z_3$		
#103			$Z_4$		
#104			$Z_5$		
#106			$Z_6$		

- (d) All three criteria shall be fulfilled for the successful completion of the cooling airflow adjustment section. In case the cooling adjustment test does not meet all metrics from Table 10.2., the testing facility shall repeat the procedure adjusting the cooling airflow accordingly;
- (e) If there is no suitable cooling airflow meeting all three metrics specified in Table 10.2., the testing facility shall select a suitable cooling airflow that fulfils the acceptable criteria for at least two parameters, one of which shall always be the average Trip #10 temperature (ABT). In such a case, if the measured brake temperature for the failing metric (IBT or FBT) is below the lower threshold value specified in Table 10.2., the testing facility shall demonstrate that a test with the minimum operational flow of the system was performed. If the measured brake temperature for the failing metric (IBT or FBT) is higher than the upper threshold value specified in Table 10.2., the testing facility shall demonstrate that a test with the maximum operational flow of the system was performed. The corresponding Event-Based and Time-Based files for the non-successful cooling adjustment tests shall be included in the test output;
- (f) If the maximum operational flow is applied and both the IBT and FBT are higher than the upper threshold values specified in Table 10.2., the testing facility shall continue with the bedding and emissions measurement section applying the maximum operational flow of the system. In such a case, the reporting data shall include the ABT, IBT, and FBT values derived from the cooling adjustment section with the application of the maximum operational flow. The corresponding Event-Based and Time-Based files shall be included in the test output. If the minimum operational flow is applied and both the IBT and FBT are below the lower threshold values specified in Table 10.2., the testing facility shall continue with the bedding and emissions measurement section applying the minimum operational flow of the system. In such a case, the reporting data shall include the ABT, IBT, and FBT values derived from the cooling adjustment section with the application of the minimum operational flow. The corresponding Event-Based and Time-Based files shall be included in the test output;

- (g) If the minimum operational flow is applied and all three temperature metrics are below the lower threshold values specified in Table 10.2., the cooling air adjustment shall be considered invalid.

#### 10.1.4. Brake Dynamometer Testing to Adjust the Cooling Airflow

The testing facility shall carry out the following steps to adjust the cooling airflow when testing a brake for the first time on a given dynamometer.

- (a) Follow the test setup preparation specifications described in paragraph 8.2.1.;
- (b) Adjust the cooling airflow to a known value used for similar brakes. In the absence of a useful reference, use an airflow of 50 per cent of the maximum test setup capacity to start the test;
- (c) Perform one run of Trip #10 of the WLTP-Brake cycle starting at a brake temperature of 40 °C. Warm up the brake to 40 °C following the instructions given in paragraph 9.2.1.;
- (d) Perform the calculations using paragraph 10.1.3. and assess the results and deviations for the target parameters;
- (e) If the test run meets all the metrics from Table 10.2., finish the process and prepare the test report in accordance with the specifications described in paragraph 13. In this case, the cooling airflow used in (b) is defined as the nominal airflow for the given brake ( $Q_{set}$ );
- (f) In the case of front brakes, proceed with the subsequent sections of the brake emissions test ensuring the application of the same dynamometer settings as in the cooling adjustment procedure. The same set of brakes shall be used for brake emissions testing;
- (g) In the case of rear brakes, proceed with the subsequent sections of the brake emissions test ensuring the application of the appropriate dynamometer settings for the rear axle. The required cooling airflow shall be the same as the value determined for the front axle brake of the corresponding vehicle;
- (h) If the test run does not meet all the metrics from Table 10.2., use sound engineering judgement to determine a new cooling airflow level and repeat the process from step (a). The same set of brakes can be used for repeating the cooling airflow adjustment section;
- (i) Report the number of iterations applied for the cooling airflow adjustment of the given brake as specified in Table 13.6. in paragraph 13.4.

## 11. Bedding Section

The bedding procedure is necessary to appropriately precondition the brake assembly and stabilise its emission behavior before performing the emissions measurement. The bedding procedure shall be carried out either with the same brake parts used during the cooling adjustment section or with completely new brake parts.

### 11.1. Front Brakes

The testing facility shall perform the bedding procedure for all types of brakes equipped at the front axle of the vehicles that fall within the scope of this UN GTR in accordance with the specifications described below:

- (a) Set the cooling airflow according to the adjustment of the cooling settings for the brake under testing as specified in paragraph 10.1.;

- (b) Define all relevant testing parameters and dynamometer settings (testing wheel load, brake test inertia, etc.) same as in the cooling adjustment and emissions measurement sections;
- (c) Apply five repetitions of the WLTP-Brake cycle for complete bedding of the front brake under testing;
- (d) The five WLTP-Brake cycles shall run consecutively without any interruption. If the test is interrupted during the bedding section, the testing facility shall follow the instructions defined in paragraph 9.3.2.;
- (e) Run each repetition of the WLTP-Brake cycle without the application of soaking sections between the individual trips of the WLTP-Brake cycle. Soaking sections shall apply only between the five repetitions of the WLTP-Brake cycle (i.e. between Trip #10 of a given WLTP-Brake cycle and Trip #1 of the following WLTP-Brake cycle);
- (f) Commence the first WLTP-Brake cycle of the bedding section at a brake temperature of  $(23 \pm 5)$  °C. Commence the subsequent four repetitions of the WLTP-Brake cycle in accordance with the temperature provisions described in paragraph 9.2.2.;
- (g) Perform the bedding section on the same dynamometer as for the emissions measurement section. Do not disassemble the brake parts between the two sections of the test to avoid modifying the contact points. If the brake parts are disassembled after the beginning of the bedding procedure, they are no longer suitable for completing bedding and emissions measurements. In such a case, the testing facility shall replace them with new brake parts and repeat the bedding procedure from the beginning.

Failure to comply with any of the provisions described in this paragraph shall result in an invalid bedding procedure. In such a case, it is not possible to proceed with the emissions measurement section. The testing facility shall perform the bedding procedure from the beginning using new brake parts.

## **11.2. Rear Brakes**

The testing facility shall perform the bedding procedure for all types of brakes equipped at the rear axle of the vehicles that fall within the scope of this UN GTR in accordance with the specifications described below:

- (a) Use the cooling airflow according to the adjustment of the cooling settings for the corresponding front brake as specified in paragraph 10.1.2.;
- (b) Define all relevant testing parameters and dynamometer settings (testing wheel load, brake test inertia, etc.) for the rear axle and use the same in the emissions measurement section;
- (c) Apply five repetitions of the WLTP-Brake cycle for complete bedding of the rear brake under testing;
- (d) The five WLTP-Brake cycles shall run consecutively without any interruption. If the test is interrupted during the bedding section, the testing facility shall follow the instructions defined in paragraph 9.3.2.;
- (e) Run each repetition of the WLTP-Brake cycle without the application of soaking sections between the individual trips of the WLTP-Brake cycle. Soaking sections shall apply only between the five repetitions of the WLTP-Brake cycle (i.e. between Trip #10 of a given WLTP-Brake cycle and Trip #1 of the following WLTP-Brake cycle);
- (f) Commence the first WLTP-Brake cycle of the bedding section at a brake temperature of  $(23 \pm 5)$  °C. Commence the subsequent four



repetitions of the WLTP-Brake cycle following the temperature provisions described in paragraph 9.2.2.;

- (g) Perform the bedding section on the same dynamometer as for the emissions measurement section. Do not disassemble the brake parts between the two sections of the test to avoid modifying the contact points. If the brake parts are disassembled after the beginning of the bedding procedure, they are no longer suitable for completing bedding and emissions measurements. In such a case, the testing facility shall replace them with new brake parts and repeat the bedding procedure from the beginning.

Failure to comply with any of the provisions described in this paragraph shall result in an invalid bedding procedure. In such a case, it is not possible to proceed with the emissions measurement section. The testing facility shall perform the bedding procedure from the beginning using new brake parts.

## 12. Emissions Measurements Section

### 12.1. Measurement of Particulate Matter Mass

This paragraph describes the specifications for the particulate matter (PM) emissions measurement during a brake emissions test. The PM sampling system enables the quantification of the PM mass generated by the brake during the test. The PM emissions and the parameters from the test provide the emissions factors for the brake under testing in mass per unit of distance driven. The test system shall measure brake PM<sub>10</sub> and PM<sub>2.5</sub> emissions gravimetrically using separate sampling systems for each cut-off diameter (2.5 µm and 10 µm). Each PM sampling system shall consist of the following elements:

- (a) One PM sampling probe located in the tunnel. The specifications for the design of the PM sampling probe are described in paragraph 12.1.1.2.;
- (b) An appropriate sampling nozzle installed at the tip of the PM sampling probe. The specifications for the design of the nozzle are described in paragraph 12.1.1.3.;
- (c) A cyclone applied as a PM separation device. The specifications for the cyclone are described in paragraph 12.1.2.1.;
- (d) A particle sampling line to transfer the aerosol from the PM separation device to the filter holder. The specifications for the design of the sampling line are described in paragraph 12.1.2.2.;
- (e) A filter placed inside the filter holder to collect the particulate matter. The specifications for the filter holder are described in paragraph 12.1.3.1.;
- (f) One or more pumps with means to control the flow rate in real-time and the corresponding sensors. The specifications for the sampling flow are described in paragraph 12.1.2.3.

In general, the setup (separate parts and connections) must be of electrically conductive materials that do not react with the brake particles and electrically grounded to avoid electrical/electrostatic effects. Figure 12.1. illustrates an indicative setup of the PM sampling unit. The positioning and dimensions of the different elements are provided for illustrative purposes; therefore, exact conformance with the figure is not required.

Figure 12.1.  
Indicative setup of the PM sampling unit

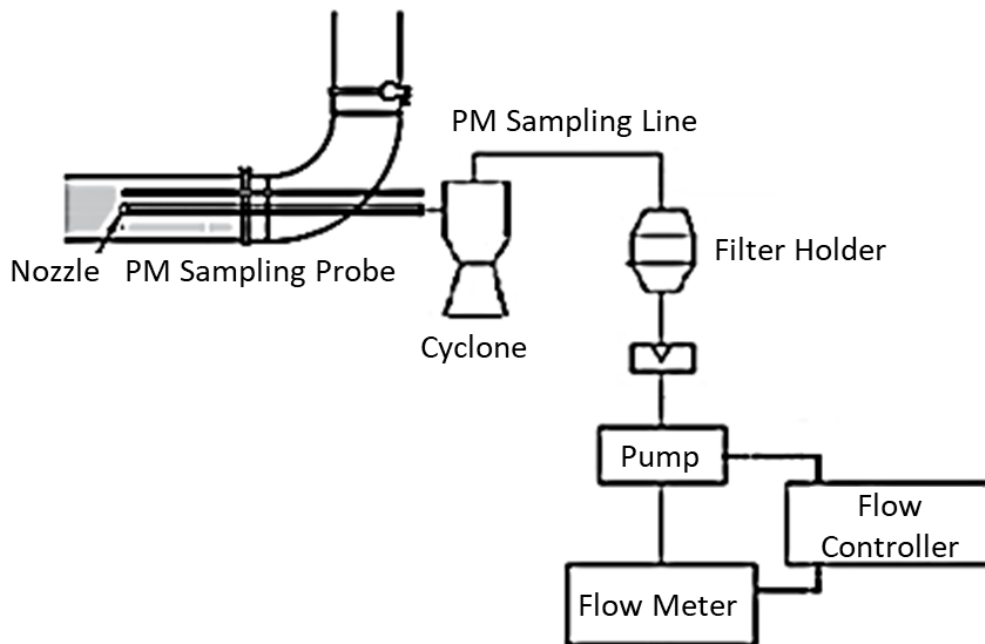

#### 12.1.1. Particulate Matter Extraction

##### 12.1.1.1. Sampling Plane

The design of the sampling plane shall follow the specifications described in paragraph 7.6. The following additional provisions apply to the sampling plane for the installation of the PM sampling probes:

- (a) Apply two sampling probes with the corresponding sampling nozzles for the PM measurements, one for PM<sub>2.5</sub> and one for PM<sub>10</sub>. White dots in Figure 7.7. indicate the PM sampling probes for both the three and four sampling probe layout;
- (b) When using the three-probe setup place the two PM sampling probes (PM<sub>2.5</sub> and PM<sub>10</sub>) at the same horizontal plane to the lower part of the tunnel as shown in Figure 7.7. (left-hand side);
- (c) When using the four-probe setup place the two PM sampling probes (PM<sub>2.5</sub> and PM<sub>10</sub>) at the same horizontal plane to the lower part of the tunnel as shown in Figure 7.7. (right-hand side);
- (d) Do not use flow splitters for PM measurements anywhere in the sampling and measurement system.

##### 12.1.1.2. PM Sampling Probes

Appropriate sampling probes shall be used to transport the aerosol from the tunnel to the separation device. The sampling probes shall meet the following design requirements:

- (a) Probes shall be appropriately designed to minimise particle losses from the nozzle tip to the separation device;
- (b) Probes shall be made of electrically conductive materials that do not react with brake particles. The probes shall be electrically grounded to avoid electrical/electrostatic effects. Probes shall be made of stainless steel with an electropolished finish (or equivalent) to the inside to attain an ultra-clean and ultra-fine surface;

- (c) Probes shall have a constant inner diameter ( $d_p$ ) of at least 10 mm and a maximum inner diameter of 18 mm ensuring a laminar flow ( $10 \text{ mm} \leq d_p \leq 18 \text{ mm}$ );
- (d) The sampling probes shall be designed to aim for the shortest possible length to minimise losses and possible tubing contamination. The overall length of the probes from the sampling nozzle tip to the inlet of the PM separation device shall not exceed 1 m;
- (e) A maximum of one bend of  $90^\circ$  may be applied to the probes provided that the specifications for the design of the bend described in point (f) of this paragraph are met;
- (f) If a bend is applied to the probes, the bending radius  $r_b$  shall be at least four times the inner diameter ( $4 \cdot d_p$ ) of the probes.

Inspect and clean the inner walls of the sampling probes frequently following the specifications of their manufacturer regarding method and frequency. If no such specifications are provided clean the probes at least once every two months of active use.

#### 12.1.1.3. PM Sampling Nozzles

Appropriate nozzles to ensure isokinetic sampling for  $PM_{10}$  and  $PM_{2.5}$  shall be used. The sampling nozzles shall meet the following requirements:

- (a) Nozzles shall be compatible with the PM sampling probes used by the testing facility for brake emissions testing;
- (b) Nozzles shall be made of stainless steel with an electropolished finish (or equivalent) to the inside to attain an ultra-clean and ultra-fine surface;
- (c) Appropriate nozzles shall be used to achieve an isokinetic ratio ( $IR$ ) of 1.0 in accordance with the specifications described in paragraph 12.1.2.4. The average isokinetic ratio in a brake emissions test shall be between 0.90-1.15 ( $0.90 \leq IR \leq 1.15$ );
- (d) The nozzle size shall be selected depending on the applied sampling flow. Nozzles shall have an inner diameter ( $d_n$ ) of at least 4 mm;
- (e) The nozzles shall have a constant inner diameter along a length equal to at least one inner diameter or at least 10 mm from the nozzle tip, whichever is greater;
- (f) Nozzles shall have a thin wall at the tip to minimise distortion of flow. These shall have an outer to inner diameter ratio lower than 1.1 at the nozzle tip;
- (g) Any variation in the bore diameter of the nozzles shall be tapered with a conical angle of less than  $30^\circ$ ;
- (h) Nozzles shall be placed with their axis parallel to that of the sampling tunnel making sure that the aspiration angle remains lower or equal to  $15^\circ$ .

The testing facility shall clean the nozzles before every brake emissions test following the specifications defined by their manufacturer regarding the cleaning means.

#### 12.1.2. PM sampling

##### 12.1.2.1. PM Separation Device

Single cyclonic separators followed by gravimetric filter holders shall be used for the collection of the  $PM_{10}$  and  $PM_{2.5}$  samples. The testing facility shall select cyclonic separators following the provisions described below:

- (a) Commercially available cyclonic separators with cut-off sizes of 10  $\mu\text{m}$  and 2.5  $\mu\text{m}$  for the collection of the  $\text{PM}_{10}$  and  $\text{PM}_{2.5}$  samples, respectively shall be used;
- (b) The  $\text{PM}_{10}$  and  $\text{PM}_{2.5}$  cyclones shall fulfil the specifications for the separation efficiency described in Tables 12.1. and 12.2., respectively;
- (c) Place the cyclonic separators at the outlet of the sampling probe. Connect the cyclonic separator directly at the outlet of the sampling probe using appropriate fittings made of conductive stainless steel. Do not use any kind of sampling tubes between the probe and the cyclonic separator.

The testing facility shall inspect and clean the inner walls of the cyclones frequently following the specifications of the instrument manufacturer regarding the method and frequency.

Table 12.1.

**Separation efficiency specifications of  $\text{PM}_{10}$  cyclonic separator**

$\text{PM}_{10}$	4 $\mu\text{m}$	8 $\mu\text{m}$	12.5 $\mu\text{m}$	20 $\mu\text{m}$
Separation Efficiency	< 20 %	< 50 %	> 60 %	> 90 %

Table 12.2.

**Separation efficiency specifications of  $\text{PM}_{2.5}$  cyclonic separator**

$\text{PM}_{2.5}$	1.5 $\mu\text{m}$	2 $\mu\text{m}$	3 $\mu\text{m}$	4 $\mu\text{m}$
Separation Efficiency	< 20 %	< 50 %	> 60 %	> 90 %

## 12.1.2.2. PM Sampling Line

The testing facility shall ensure that the design of the sampling line that transfers the aerosol from the cyclonic separator to the filter holder meets the specifications described below:

- (a) The sampling line shall be appropriately designed to minimise particle transport losses between the outlet of the cyclonic separator and the inlet of the filter holder;
- (b) The sampling line shall be made of conductive stainless steel with the appropriate fittings. Alternatively, flexible antistatic polytetrafluoroethylene (PTFE) sampling lines may be used;
- (c) The sampling line shall have a constant inner diameter ( $d_s$ ) of at least 10 mm and a maximum of 20 mm ( $10 \text{ mm} \leq d_s \leq 20 \text{ mm}$ );
- (d) The overall length of the sampling line from the outlet of the cyclonic separator to the tip of the filter holder shall not exceed 1 m in total;
- (e) The PM sampling system's part outside the tunnel (the part of the PM sampling system that includes the cyclonic separator and the PM sampling line) shall be designed in a way that no condensation of water can occur. The temperature inside the sample train shall always remain above 15 °C;
- (f) A bend may be applied to the sampling line provided that the bending radius  $r_b$  is at least twenty-five times the inner diameter ( $25 \cdot d_s$ ) of the sampling line.

### 12.1.2.3. PM Sampling Flow

The testing facility shall apply the following provisions for the regulation and measurement of the sampling flow:

- (a) The method of measuring the flow of the sampling system ( $Q_{PM2.5}$  and  $Q_{PM10}$ ) shall have a maximum permissible error of  $\pm 2.5$  per cent of the reading or  $\pm 1.5$  per cent of the full-scale, whichever is the smallest, under all operating conditions;
- (b) A flow measurement device calibrated to report flow at standard conditions shall be used. To ensure an appropriate conversion to operating conditions, the temperature sensor shall have an accuracy of  $\pm 1.0$  °C and the pressure measurements shall have a precision and accuracy of  $\pm 1.0$  kPa;
- (c) The set (nominal) values for the sampling volumetric flows ( $Q_{PM2.5-set}$  and  $Q_{PM10-set}$ ) shall be constant during the emissions measurement section of the brake under testing;
- (d) The average sampling volumetric flow shall be within  $\pm 2$  per cent of the set value for the given brake emissions test. A device with a flow control feature (e.g. critical orifice, pressure regulator, feedback controller, or other) shall be used to ensure a stable flow through the filter medium;
- (e) Calculate and report the deviation of the average measured sampling volumetric flow from the set value for both  $PM_{10}$  and  $PM_{2.5}$  using the data of the given parameters in the Time-Based file as defined in Table 13.6. in paragraph 13.4.;
- (f) The sampling flow shall be set such that the isokinetic ratio is as close as possible to 1.0. The average isokinetic ratio during the emissions measurement section of a specific brake shall be between 0.90-1.15 (paragraph 12.1.2.4.). Calculate and report the average isokinetic ratio for both  $PM_{2.5}$  and  $PM_{10}$  following the procedure described in paragraph 12.1.2.4.;
- (g) Checks for possible leaks by sealing the nozzle and starting the suction device shall be undertaken. The flow rate shall be at most 2 per cent of the normal flow rate at the maximum vacuum reached during sampling. Perform the leak check upon the system installation and after every maintenance or upgrade following the manufacturer's specifications;
- (h) In case the sampling volumetric flow and/or the isokinetic requirements set out in this paragraph are not met, the test shall be invalid;
- (i) The PM sampling device shall operate continuously during the brake emissions measurement section. This also includes the soaking sections between the individual trips of the WLTP-Brake cycle where the PM sampling flow shall not be paused or bypass the main sampling line. The PM sampling device shall operate for at least 10 s more after the end of the brake emissions measurement section.

### 12.1.2.4. Isokinetic Ratio

Sampling is defined as isokinetic when the airspeed in the sampling tunnel and the sampling nozzle are equal. The airspeed is calculated from the airflow values in the tunnel and in the nozzle taking into account their inner diameters ( $d_t$  and  $d_n$ , respectively). Equations 12.1 and 12.2 apply for the calculation of the airspeed in the sampling tunnel and the sampling nozzle:

$$U = (4 \times 1000 \times Q) / (\pi \times d_t^2) \quad (\text{Eq. 12.1})$$

$$U_s = (4 \times 1000 \times Q_s) / (\pi \times d_n^2) \quad (\text{Eq. 12.2})$$

Where:

- U is the average airspeed in the tunnel in km/h per Table 13.2.;
- $U_s$  is the average speed of the sampling air entering the nozzle in km/h;
- Q is the average airflow in the tunnel in m<sup>3</sup>/h per Table 13.2.;
- $Q_s$  is the average airflow in the sampling nozzle in m<sup>3</sup>/h;
- $d_n$  is the inner diameter at the nozzle tip in mm;
- $d_i$  is the sampling tunnel's inner diameter in mm per Table 7.1.

The isokinetic ratio is defined as the ratio of the airspeed in the sampling nozzle to the airspeed in the sampling tunnel. Equation 12.3 provides the means to calculate the isokinetic ratio by combining Equations 12.1 and 12.2. The airflow values in the sampling tunnel and the nozzle shall refer to the same temperature and pressure conditions; therefore, normalised values shall be used to ensure comparability also between different testing facilities:

$$IR = (NQ_s/d_n^2)/(NQ/d_i^2) \quad (\text{Eq. 12.3})$$

Where:

- IR is the isokinetic ratio;
- $NQ_s$  is the average normalised airflow in the sampling nozzle in Nm<sup>3</sup>/h;
- $NQ$  is the average normalised airflow in the sampling tunnel in Nm<sup>3</sup>/h per Table 13.2.;
- $d_n$  is the inner diameter at the nozzle tip in mm;
- $d_i$  is the sampling tunnel's inner diameter in mm per Table 7.1.

Converting the sampling flow units from [Nm<sup>3</sup>/h] to [l/min] and the inner diameter units from [m] to [mm] to reflect conventional units, Equation 12.3 becomes Equation 12.4.

$$IR = 0.06 \times (NQ_s/d_n^2)/(NQ/d_i^2) \quad (\text{Eq. 12.4})$$

Where:

- IR is the isokinetic ratio;
- $NQ_s$  is the average normalised airflow in the sampling nozzle in l/min;
- $NQ$  is the average normalised airflow in the sampling tunnel in Nm<sup>3</sup>/h per Table 13.2.;
- $d_n$  is the inner diameter at the nozzle tip in mm;
- $d_i$  is the sampling tunnel's inner diameter in mm per Table 7.1.

The testing facility shall calculate the average isokinetic ratio during the emissions measurement section of a brake emissions test for both PM<sub>2.5</sub> and PM<sub>10</sub>, separately, using Equation 12.4:

- (a) Use the corresponding values for the isokinetic nozzle inner diameters for PM<sub>2.5</sub> ( $d_{n-PM2.5}$ ) and PM<sub>10</sub> ( $d_{n-PM10}$ ) sampling;
- (b) Use the data of the average normalised tunnel flow ( $NQ$ ) and the average normalised sample flows ( $NQ_{PM2.5}$  and  $NQ_{PM10}$ ) in the Time-Based file;
- (c) Report the calculated values as specified in Table 13.6. in paragraph 13.4.

### 12.1.3. Sampling Media

#### 12.1.3.1. Filter Holder

The PM samples shall be collected on 47 mm single filters per test mounted within a dedicated holder. The filter holder shall be located as close as possible to the cyclonic separator's outlet. The testing facility shall follow the specifications described below for the filter holder assembly:

- (a) Select a filter holder made of inert and non-corroding material such as stainless steel or anodized aluminium;
- (b) Use a filter holder suitable for the insertion of circular filters. The diameter of the exposed area through which the sampled air passes (i.e. filter stain area) shall be between 34 mm and 44 mm;
- (c) Use a filter holder that provides an even flow distribution across the filter stain area;
- (d) Design the filter holder arrangement in a way that no condensation of water can occur. The temperature at the filter holder shall follow the specification for the entire sample path defined in paragraph 12.1.2.2. and shall always remain above 15 °C during the entire brake emissions test.

#### 12.1.3.2. Sampling Filters

Fluorocarbon-coated glass fibre filters or fluorocarbon membrane filters shall be used for the PM<sub>10</sub> and PM<sub>2.5</sub> measurements. All filter types shall have a 0.3 µm DOP (Diocetyl phthalate) or PAO (poly-alpha-olefin) CS 68649-12-7 or CS 68037-01-4 collection efficiency of at least 99 per cent at a gas filter face velocity of 5.33 cm/s measured according to one of the following standards:

- (a) U.S.A. Department of Defense Test Method Standard, MIL-STD-282 method 102.8: DOP-Smoke Penetration of Aerosol-Filter Element;
- (b) U.S.A. Department of Defense Test Method Standard, MIL-STD-282 method 502.1.1: DOP-Smoke Penetration of Gas-Mask Canisters;
- (c) Institute of Environmental Sciences and Technology, IEST-RP-CC021: Testing HEPA and ULPA Filter Media.

The efficiency requirements for the sampling media described in this paragraph shall be certified by the filter supplier.

#### 12.1.4. Weighing Procedure

Only the filter shall be weighed and not any other part of the measurement equipment. The testing facility shall ensure that the different steps of the weighing procedure are carried out according to the following requirements:

- (a) Weighing room – The weighing room environment shall be free of any ambient contaminants (such as dust, aerosol, or semi-volatile material) that could contaminate the particle filters. Regulate the weighing room environmental conditions at  $22 \pm 2$  °C and  $45 \pm 8$  per cent RH. Make sure that the air flow for the air exchange does not influence the balance stability;
- (b) Weighing balance – Use the same microbalance for both pre-sampling and post-sampling weighing for a given brake emission test. Isolate the balance from vibrations, electrostatic forces, and air streams. Place the balance in a controlled environment – the weighing chamber or room – in accordance with the specifications described in point (a) of this paragraph. The balance resolution shall be of at least 1 µg. Use certified calibration weights to verify the stability and the proper function of the

microbalance. The microbalance shall fulfil the calibration requirements described in paragraph 14.4.;

- (c) Static electricity effects – Nullify the effects of static electricity by grounding the balance through placement upon an antistatic mat and neutralizing the particle sampling filters before weighing using a polonium neutralizer or a device of similar effect. Alternatively, nullify static effects through equalisation of static charge;
- (d) Pre-sampling conditioning and weighing – Condition/stabilise the filters at  $(22 \pm 2)$  °C and  $(45 \pm 8)$  per cent RH for a minimum of 2 hours before weighing. Weigh the filter at the end of the stabilisation period following the procedure described in (g) of this paragraph and register its weight in all relevant test sheets. No deviation from the conditions specified in this paragraph is permitted during the weighing operation. Store the filter in a closed petri dish (or equivalent) or sealed filter holder until testing. Place the filter in the filter holder within 1h of its removal from the weighing chamber (or room). Use the closed petri dish (or equivalent) or sealed filter holder to transfer the filter to the test rig. Alternatively, mount the filter in the filter holder already in the weighing chamber;
- (e) Post-sampling conditioning and weighing – Take the filters to the conditioning room within 8 hours after testing is completed. Use a closed petri dish (or equivalent) or sealed filter holder to transfer the filter to the conditioning room. Alternatively, transfer the filter without removing it from the filter holder ensuring that filter holders are not tilted during transfer. Condition/stabilise the filters at  $(22 \pm 2)$  °C and  $(45 \pm 8)$  per cent RH for a minimum of 2 hours. Weigh the filter at the end of the stabilisation period following the procedure described in (g) of this paragraph and register its weight in all relevant test sheets. No deviation from the conditions specified in this paragraph is permitted during the weighing operation. Store the filter in a closed petri dish (or equivalent) or sealed filter holder;
- (f) Reference filter weighing – Use reference filters to validate PM weighing. Select at least two Fluorocarbon coated glass fibre or fluorocarbon membrane reference filters that match each sampled filter media. Weigh the reference filters at the beginning and the end of a weighing session (before pre-sampling and after post-sampling weighing) and report the weights in the Mass Measurement File. The average difference between the initial and final measurement for the reference filter shall remain within  $\pm 10$  µg. Furthermore, the average difference between the reference filters and their moving average (min 1 day – max 15 days) shall be within  $\pm 10$  µg. Replace the reference filters at a maximum every 30 days and in such a manner that no sample filter is weighted without comparison to a reference filter that has been present in the weighing chamber (room) for at least one day;
- (g) Sample filter weighing – Follow the procedure described below to perform both pre- and post-sampling filter weighing:
  - (i) Weigh the filter twice and report the weights in the Mass Measurement File;
  - (ii) If the difference between the first and second measurements is 30 µg or less, use the arithmetic mean to report the  $Pe_{(Uncorrected)}$  and calculate the  $Pe_{(Corrected)}$  weights in accordance with point (h) of this paragraph;
  - (iii) If the difference between the first and second weighings is greater than 30 µg, perform two additional weighings and report the weights in the Mass Measurement File;



- (iv) When the difference between the minimum and maximum weights of the four measurements is 38 µg or less, use the arithmetic mean of the four weights to report the  $Pe_{(Uncorrected)}$  and calculate the  $Pe_{(Corrected)}$  weights in accordance with point (h) of this paragraph;
  - (v) When the difference between the minimum and maximum weights of the four measurements is greater than 38 µg and less than or equal to 42 µg, use the median of the four values to report the  $Pe_{(Uncorrected)}$  and calculate the  $Pe_{(Corrected)}$  weights in accordance with point (h) of this paragraph. The median value is the arithmetic mean of the second-lowest and the third-lowest values among the four weights taken;
  - (vi) When the difference between the minimum and maximum weights of the four measurements is greater than 42 µg invalidate the weighing session and quarantine the filter in the conditioning room. The testing facility may decide to void the filter and replace it with a new filter for a pre-sampling weighing session, or discard the filter and repeat the brake emissions test for a post-sampling weighing session;
  - (vii) After a minimum of 24h take the filter out of quarantine and weigh it twice in accordance with points (i) and (ii) in this paragraph;
  - (viii) If the difference between the first and second new measurements is greater than 30 µg, void the filter and reject the weighing session. Use a new filter for a pre-sampling weighing session, or discard the filter and repeat the brake emissions test for a post-sampling weighing session.
- (h) Buoyancy correction – Correct the sample and reference filter weights for their buoyancy in air. The buoyancy correction is a function of sampling filter density, air density, and the density of the balance calibration weight, and does not account for the buoyancy of the particulate matter itself.

Use the following values for the density of the filter material ( $p_f$ ) when it is not known: (a) Fluorocarbon coated glass fibre filter: 2300 kg/m<sup>3</sup>; (b) Fluorocarbon membrane filter: 2144 kg/m<sup>3</sup>.

Use a density ( $p_w$ ) of 8000 kg/m<sup>3</sup> for stainless steel calibration weights or the known density for different calibration weight materials. Follow the International Recommendation OIML R 111-1 Edition 2004(E) (or equivalent) from the International Organization of Legal Metrology on calibration weights.

Use the uncorrected average filter mass measurement to calculate the buoyance-corrected average filter mass measurement for PM<sub>2.5</sub> and PM<sub>10</sub> filters (pre- and post-sampling) following Equation 12.5. Report the corrected measurements in the Mass Measurement File:

$$Pe_{(Corrected)} = Pe_{(Uncorrected)} \times [1 - (p_a/p_w)]/[1 - (p_a/p_f)] \quad (\text{Eq. 12.5})$$

Where:

- $Pe_{(Corrected)}$  is the corrected mass for each filter in mg;
- $Pe_{(Uncorrected)}$  is the uncorrected mass for each filter in mg per Table 12.4.;
- $p_a$  is the density of air in the balance room per Equation 12.6 in kg/m<sup>3</sup>;

- $p_w$  is the density of the calibration balance weight per paragraph (e);
- $p_f$  is the density of the (unused) sampling filter per paragraph (e).

Use the conditions in the balance room at the time of weighing to calculate the density of air, following Equation 12.6.

$$p_a = (p_b \times M_{\text{mix}})/(R \times T_a) \quad (\text{Eq. 12.6})$$

Where:

- $p_a$  is the density of air in the balance room in  $\text{kg/m}^3$ ;
- $p_b$  is the atmospheric pressure in the balance room in kPa;
- $M_{\text{mix}}$  is the molar mass of air in the balance room,  $28.836 \text{ g mol}^{-1}$ ;
- $R$  is the molar mass constant,  $8.3144 \text{ J mol}^{-1} \text{ K}^{-1}$ ;
- $T_a$  is the air temperature in the balance room in K.
- (i) Filter load – Subtract the average pre-sampling filter mass measurement from the post-sampling filter mass measurement. Use the buoyance-corrected average filter mass measurements calculated in point (h) of this paragraph. Calculate and report both  $\text{PM}_{2.5}$  ( $\text{Pe}_{(2.5)}$ ) and  $\text{PM}_{10}$  ( $\text{Pe}_{(10)}$ ) filter loads in the Mass Measurement File. Report the  $\text{PM}_{2.5}$  and  $\text{PM}_{10}$  filter loads as specified in Table 13.6. in paragraph 13.4.;
- (j) Storage and transfer conditions – Keep weighed filters in appositely made filter boxes designed to host the specific filter size. Use stainless steel forceps or tongs for filter handling. Minimise filter movement within the Petri dishes/bags and transport as much as possible. Carefully install the particle sample filter into the filter holder. Rough or abrasive filter handling will result in erroneous weight determination.

#### 12.1.5. PM Emission Factor Calculation

The testing facility shall report the PM emissions in mass per distance driven. Calculate the reference (or initial)  $\text{PM}_{2.5}$  and  $\text{PM}_{10}$  emission factors of the tested brake ( $\text{EF}_{\text{ref}}$ ) following Equations 12.7 and 12.8, respectively.

$$\text{PM}_{2.5} \text{ EF}_{\text{ref}} = [\text{Pe}_{(2.5)} \times 1000 \times (NQ/60)/NQ_{\text{PM}_{2.5}}]/d \quad (\text{Eq. 12.7})$$

$$\text{PM}_{10} \text{ EF}_{\text{ref}} = [\text{Pe}_{(10)} \times 1000 \times (NQ/60)/NQ_{\text{PM}_{10}}]/d \quad (\text{Eq. 12.8})$$

Where:

- $\text{PM}_{2.5} \text{ EF}_{\text{ref}}$  is the reference  $\text{PM}_{2.5}$  emission factor for the tested brake in mass per distance driven in  $\text{mg/km}$ ;
- $\text{PM}_{10} \text{ EF}_{\text{ref}}$  is the reference  $\text{PM}_{10}$  emission factor for the tested brake in mass per distance driven in  $\text{mg/km}$ ;
- $\text{Pe}_{(2.5)}$  is the  $\text{PM}_{2.5}$  filter mass load in  $\text{mg}$  per Table 13.3.;
- $\text{Pe}_{(10)}$  is the  $\text{PM}_{10}$  filter mass load in  $\text{mg}$  per Table 13.3.;
- $NQ$  is the average normalised airflow in the sampling tunnel in  $\text{Nm}^3/\text{h}$  per Table 13.2.;
- $NQ_{\text{PM}_{2.5}}$  is the average normalised airflow in the  $\text{PM}_{2.5}$  sampling nozzle in  $\text{ml/min}$  per Table 13.2.;

- $NQ_{PM_{10}}$  is the average normalised airflow in the  $PM_{10}$  sampling nozzle in  $l/min$  per Table 13.2.;
- d is the total distance driven during the WLTP-Brake cycle in km per Table 13.2.
- Calculate the  $PM$  masses ( $Pe_{(10)}$  and  $Pe_{(2.5)}$ ) as specified in paragraph 12.1.4. (i) after correcting the values for buoyancy as specified in paragraph 12.1.4. (h);
  - Calculate the average normalised tunnel flow ( $NQ$ ), the average normalised sampling flows ( $NQ_{PM_{2.5}}$  and  $NQ_{PM_{10}}$ ), and the total distance of the WLTP-Brake cycle (d) over the emissions measurement section from the given parameters in the Time-Based file;
  - Calculate the  $PM_{2.5}$  and  $PM_{10}$   $EF_{ref}$  of the tested brake following Equations 12.7 and 12.8, respectively. Then, use the friction braking share coefficient in Table 5.1. to calculate the final  $PM_{2.5}$  and  $PM_{10}$   $EF$  of the tested brake. Apply the friction braking share coefficient that corresponds to the vehicle type of which the parameters were used for testing the brake. Use Equations 12.9 and 12.10 for the calculation of the final  $PM_{2.5}$  and  $PM_{10}$ , respectively:

$$PM_{2.5} EF = PM_{2.5} EF_{ref} * c \quad (\text{Eq. 12.9})$$

$$PM_{10} EF = PM_{10} EF_{ref} * c \quad (\text{Eq. 12.10})$$

- Report the final  $PM_{2.5}$  and  $PM_{10}$   $EF$  as specified in Table 13.6. in paragraph 13.4.

## 12.2. Measurement of Particle Number (PN) Concentration

This paragraph describes the specifications for the PN emissions measurement during brake emissions testing. The PN sampling and measurement systems enable the quantification of the number of particles generated by the brake during the test. The measured PN emissions along with the parameters from the test provide the emissions factors for the brake under testing in the number of particles emitted per unit of distance driven.

Figure 12.2.

### Indicative setup of the PN sampling and measurement unit

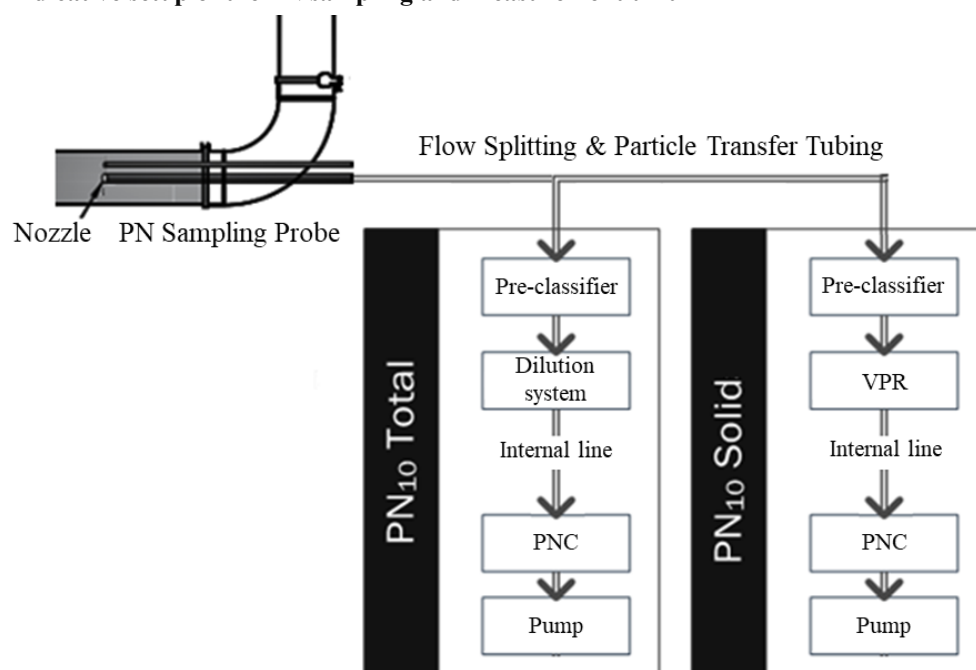

In general, the setup (separate parts and connections) must be of electrically conductive materials that do not react with the brake particles and electrically grounded to avoid electrical/electrostatic effects. Figure 12.2. illustrates an indicative PN sampling and measurement setup. The test system shall be capable of measuring Total-PN (TPN10) and Solid-PN (SPN10) at a nominal particle size of approximately 10 nm electrical mobility diameter and larger. The positioning and dimensions of the different elements are provided for illustration purposes; therefore, exact conformance with the figure is not required. The TPN10 sampling and measurement systems shall consist of the following elements:

- (a) A PN sampling probe that extracts a sample from the sampling tunnel. The specifications for the design of the PN sampling probe are described in paragraph 12.2.1.2.;
- (b) An appropriate PN sampling nozzle that is installed at the tip of the PN sampling probe. The specifications for the design of the nozzle are described in paragraph 12.2.1.3.;
- (c) A suitable tube (Particle Transfer Tube – PTT) that transfers aerosol from the outlet of the sampling probe to the inlet of the PN pre-classifier. When the PN pre-classifier is directly mounted to the outlet of the sampling probe, the PTT may be used to transfer the particles from the outlet of the PN pre-classifier to the inlet of the dilution system. The specifications for the design of the PTT are described in paragraph 12.2.1.4.;
- (d) A PN pre-classifier that is applied to remove bigger particles. The specifications for the PN pre-classifier are described in paragraph 12.2.2.1.;
- (e) A dilution system that incorporates one or more dilution stages. The specifications for the design of the dilution system are described in paragraph 12.2.2.2.;
- (f) An internal transfer line that transfers the aerosol from the outlet of the dilution system to the inlet of the particle number counting device. The specifications for the design of the transfer line are described in paragraph 12.2.2.3.;
- (g) A Particle Number Counter (PNC) that measures the TPN10 concentration. The specifications for the PNC are described in paragraph 12.2.3.1;

The SPN10 sampling and measurement systems shall consist of the following elements:

- (h) A PN sampling probe that extracts a sample from the sampling tunnel. The specifications for the design of the PN sampling probe are described in paragraph 12.2.1.2.;
- (i) An appropriate PN sampling nozzle that is installed at the tip of the PN sampling probe. The specifications for the design of the nozzle are described in paragraph 12.2.1.3.;
- (j) A suitable PTT that transfers aerosol from the outlet of the sampling probe to the inlet of the PN pre-classifier. When the PN pre-classifier is directly mounted to the outlet of the sampling probe, the PTT may be used to transfer the particles from the outlet of the PN pre-classifier to the inlet of the volatile particle remover system. The specifications for the design of the PTT are described in paragraph 12.2.1.4.;
- (k) A PN pre-classifier that is applied to remove bigger particles. The specifications for the PN pre-classifier are described in paragraph 12.2.2.1.;

- (l) A Volatile Particle Remover (VPR) that dilutes the sample and removes volatile particles prior to measuring PN. The specifications for the design of the VPR are described in paragraph 12.2.2.2.;
- (m) An internal transfer line that transfers the aerosol from the outlet of the VPR to the inlet of the PNC. The specifications for the design of the transfer line are described in paragraph 12.2.2.3.;
- (n) A PNC that measures the SPN10 concentration. The specifications for the PNC are described in paragraph 12.2.3.1.

TPN10 and SPN10 sampling shall use different probes as specified in 12.2.1.1.

- (a). The same sampling probe can be used provided that the applied flow splitter fulfils the requirements specified in paragraph 12.2.1.1. (b-e).

#### 12.2.1. Sample Extraction

##### 12.2.1.1. Sampling Plane

The design of the sampling plane shall follow the specifications described in paragraph 7.6. The following additional specifications shall be applied to the sampling plane for the installation of the PN sampling probes:

- (a) Apply two sampling probes for the PN emissions measurements, one for TPN10 and one for SPN10. Black dots in Figure 7.7. (right-hand side) indicate the PN sampling probes for the four-sampling probe layout;
- (b) Alternatively, use a single sampling probe for both TPN10 and SPN10 applying an appropriate flow-splitting device as specified in points (c-e) of this paragraph. The black dot in Figure 7.7. (left-hand side) indicates the PN sampling probe for the three-sampling probe layout;
- (c) When applying a flow splitting device, it shall be made from stainless steel and an electropolished interior to minimise particle losses from wall deposition;
- (d) When applying a flow splitting device, keep the change in the flow angle within  $20^\circ$  ( $\leq 20^\circ$ ) for each outlet to ensure similar flow velocities in all branches. Verify that the flow velocities in the different branches do not differ from each other by more than  $\pm 5$  per cent;
- (e) When applying a flow splitting device, demonstrate that the penetration with and without the splitter remains within  $\pm 5$  per cent at the nominal flows of the PN systems connected. Let the systems stabilise (flow velocity is within  $\pm 5$  per cent of nominal value) for at least 30 seconds before starting the measurement. Perform the comparison with and without the flow splitter by measuring the particle penetration at 15 nm and 1.5  $\mu\text{m}$  for at least 30 seconds after the stabilisation period.

##### 12.2.1.2. PN Sampling Probes

Appropriate PN sampling probe(s) shall be used to extract the sample from the tunnel to the inlet of the particle transfer tube or the PN pre-classifier. The PN sampling probe(s) shall meet the following design requirements:

- (a) Use probe(s) appropriately designed to minimise particle losses from the nozzle tip to the inlet of the particle transfer tube;
- (b) Use probe(s) made of electrically conductive materials that do not react with brake particles. The probes shall be electrically grounded to avoid electrical/electrostatic effects. Use probe(s) made of stainless steel with an electropolished finish (or equivalent) to attain an ultra-clean and ultra-fine surface;

- (c) Select probe(s) with a constant inner diameter ( $d_p$ ) of at least 10 mm and a maximum of 18 mm ensuring a laminar flow ( $10 \text{ mm} \leq d_p \leq 18 \text{ mm}$ ) under all operating conditions;
- (d) The overall length of the probe(s) from the sampling nozzle tip to the inlet of the particle transfer tube or the PN pre-classifier shall not exceed 1 m;
- (e) The residence time from the inlet of the nozzle tip to the inlet of the particle transfer tube or the PN pre-classifier shall be below 3s;
- (f) A maximum of one bend of  $90^\circ$  may be applied to the probes provided that the bending radius  $r_b$  is at least four times the inner diameter ( $4 \cdot d_p$ ) of the PN sampling probe(s).

#### 12.2.1.3. PN Sampling Nozzles

Appropriate nozzles to ensure isokinetic sampling based on the total extracted sampling flow and the average cooling airflow shall be used. The testing facility shall select PN sampling nozzles for both TPN<sub>10</sub> and SPN<sub>10</sub> sampling that meet the following requirements:

- (a) Use nozzles made of stainless steel with an electropolished finish (or equivalent) to the inside to attain an ultra-clean and ultra-fine surface;
- (b) Use the appropriate nozzles to achieve an isokinetic ratio in the range of 0.6 to 1.5;
- (c) Select the nozzle size depending on the applied flow to keep the isokinetic ratio (paragraph 12.1.2.4.) within the specifications defined in point (b) of this paragraph. Do not use nozzles with an inner diameter lower than 4 mm;
- (d) The nozzles shall have a constant internal diameter along a length equal to at least one internal diameter or at least 10 mm from the nozzle tip, whichever is greater;
- (e) Use nozzles with a thin wall at the tip to minimise distortion of flow. These shall have an outer to inner diameter ratio lower than 1.1 at the nozzle tip;
- (f) Any variation in the bore diameter of the nozzles shall be tapered with a conical angle of less than  $30^\circ$ ;
- (g) Place the nozzles with their axis parallel to that of the sampling tunnel making sure that the aspiration angle remains lower or equal to  $15^\circ$ .

The testing facility shall clean the nozzles before every brake emissions test following the specifications defined by their manufacturer regarding the cleaning means.

#### 12.2.1.4. Particle Transfer Tube

When the PN pre-classifier is not directly connected to the probe's outlet, a suitable particle transfer tube (PTT) shall be used to transfer aerosol from the probe's outlet to the PN pre-classifier's inlet. When the PN pre-classifier is directly connected to the probe's outlet, the PTT shall be used to transfer aerosol from the PN pre-classifier's outlet to the sample conditioning system's inlet. In any case, only a single PTT may be used and its design shall meet the following requirements for both TPN<sub>10</sub> and SPN<sub>10</sub> sampling:

- (a) Use transfer tubes appropriately designed to minimise particle transport losses between the probe's outlet and the PN pre-classifier's inlet or the PN pre-classifier's outlet and the sample conditioning system's inlet;
- (b) When there is a change in diameter between the probe's outlet and the PN pre-classifier's inlet or the PN pre-classifier's outlet and the sample

conditioning system's inlet, use transfer tubes with gradual diameter changes;

- (c) Use transfer tubes made of electrically conductive materials that do not react with brake aerosol components;
- (d) Select transfer tubes with an inner diameter ( $d_{it}$ ) of at least 4 mm ensuring a laminar flow under all operating conditions;
- (e) The length of the transfer tubes to sample flow ratio shall be below 60000 s/m<sup>2</sup>;
- (f) The particles' residence time inside the transfer tubes shall be below 1 s;
- (g) A bend may be applied to the transfer tubes provided that the bending radius  $r_b$  shall be at least twenty-five times the tube diameter ( $25 \cdot d_{it}$ ).

## 12.2.2. Sample Treatment and Conditioning

### 12.2.2.1. PN Pre-classifier

The testing facility shall use a cyclonic separator to protect the dilution system and the VPR from possible contamination. The testing facility shall ensure that the PN pre-classifier for both TPN10 and SPN10 sampling and measurement meets the following requirements:

- (a) Use two cyclonic separators when applying different sampling probes for the TPN10 and SPN10 emissions measurements;
- (b) When a single sampling probe is used for both TPN10 and SPN10, use one cyclonic separator when placed upstream of the flow-splitting device. Alternatively, two cyclonic separators shall be used when placed downstream of the flow-splitting device;
- (c) Place the cyclonic separator either at the outlet of the sampling probe or at the inlet of the sample conditioning system;
- (d) Use commercially available cyclonic separators with a 50 per cent cut point particle diameter between 2.5  $\mu\text{m}$  and 10  $\mu\text{m}$  at the volumetric sample flow rate that passes through the cyclonic separator;
- (e) The cyclone shall achieve a minimum penetration efficiency of 80 per cent for a particle diameter of 1.5  $\mu\text{m}$ .

The testing facility shall inspect and clean the inner walls of the cyclones frequently following the specifications of the instrument manufacturer regarding the cleaning frequency and means.

### 12.2.2.2. Sample Conditioning

The aerosol entering the PN system shall undergo conditioning before entering the PNC. The testing facility shall ensure the sample conditioning system meets the following requirements depending on the measured parameter:

#### TPN<sub>10</sub>

A dilution system is mandatory and shall comprise at least one particle diluter. A dilution system like the VPR for SPN10 described in the next paragraph may be used. In such a case, any active heating of the evaporation tube and the diluters shall be deactivated. The following specifications apply to the dilution system for conditioning the aerosol when measuring TPN10:

- (a) All parts of the dilution system that come in contact with the sample shall be made of electrically conductive materials, shall be electrically grounded to prevent electrostatic effects, and shall be designed to minimise deposition of the particles;

- (b) It shall be capable of diluting the sample in one or more stages to achieve a PN concentration below the upper threshold of the single-particle count mode of the PNC. The dilution system shall be capable of providing a dilution factor of at least 10:1;
- (c) It shall be capable of keeping the dilution factor constant ( $\pm 5$  per cent of the set value) throughout the entire emissions test;
- (d) It shall be capable of maintaining the diluted gas temperature below 38 °C;
- (e) It shall be supplied with dilution air filtered through a HEPA filter of at least class H13 (EN 1822:2008), or equivalent performance;
- (f) It shall achieve a particle concentration reduction factor (PCRF) for particles of 15 nm, 30 nm, and 50 nm electrical mobility diameters not higher than 100 per cent, 30 per cent, and 20 per cent, respectively, compared to particles of 100 nm electrical mobility diameter for the system as a whole. Additionally, it shall achieve a PCRF for particles of 15 nm, 30 nm, and 50 nm not lower than 5 per cent than that for particles of 100 nm for the system as a whole. The calculation of the PCRF at different sizes shall follow the method described in paragraph 14.5.1.;
- (g) It shall monitor the dilution factor variation in real-time to report the arithmetic average PCRF ( $f_{r-TPN10}$ ) at a frequency of 1 Hz. The calculation of the arithmetic average PCRF shall follow the method described in paragraph 14.5.1;
- (h) It shall report PCRF-corrected TPN10 concentrations at standard conditions at a reporting frequency equal to or greater than 0.5 Hz;
- (i) It shall achieve a total particle penetration efficiency of at least 70 per cent for particles of 100 nm electrical mobility diameter;
- (j) It shall be capable of operating at sample pressures in the 850 to 1050 mbar range and relative pressure differences from ambient in the  $\pm 50$  mbar range;

#### SPN<sub>10</sub>

The volatile particle remover (VPR) shall comprise at least one particle number diluter (PND1) and an evaporation tube. A second diluter (PND2) may be optionally installed in series with the PND1 and the evaporation tube. The following specifications apply to the VPR for conditioning the aerosol when measuring SPN<sub>10</sub>:

- (k) All parts of the VPR that come in contact with the sample shall be made of electrically conductive materials, shall be electrically grounded to prevent electrostatic effects, and shall be designed to minimise deposition of the particles;
- (l) It shall be capable of diluting the sample in one or more stages to achieve a PN concentration below the upper threshold of the single-particle count mode of the PNC. The overall system shall be capable of providing a dilution factor of at least 10:1;
- (m) It shall be capable of maintaining the gas temperature below the maximum allowed inlet temperature specified by the PNC manufacturer;
- (n) It may include an initial heated dilution stage which outputs the sample at a wall temperature between 150 °C and 350 °C. The wall temperature set point shall not exceed the wall temperature of the evaporation tube. The diluter shall be supplied with air filtered through a HEPA filter of at least class H13 (EN 1822:2008), or equivalent performance;



- (o) It shall include a catalytically active evaporation tube which is controlled to a wall temperature greater than or equal to that of the PND1. The wall temperature of the evaporation tube shall remain at a fixed nominal operating temperature of 350 °C;
- (p) It shall control heated stages to constant nominal operating temperatures to a tolerance of  $\pm 10$  °C. Additionally, the VPR system shall indicate whether heated stages are at their correct operating temperatures;
- (q) It shall achieve a PCRF for particles of 15 nm, 30 nm, and 50 nm electrical mobility diameters not higher than 100 per cent, 30 per cent, and 20 per cent, respectively, compared to particles of 100 nm electrical mobility diameter for the VPR as a whole. Additionally, it shall achieve a PCRF for particles of 15 nm, 30 nm, and 50 nm not lower than 5 per cent than that for particles of 100 nm for the VPR as a whole. The calculation of the PCRF at different sizes shall follow the method described in paragraph 14.5.1.;
- (r) It shall monitor the dilution factor variation in real-time to report the arithmetic average PCRF ( $f_{r-SPN10}$ ) at a frequency of 1 Hz. The calculation of the arithmetic average PCRF shall follow the method described in paragraph 14.5.1.;
- (s) It shall report PCRF-corrected SPN10 concentrations at standard conditions at a reporting frequency equal to or greater than 0.5 Hz;
- (t) It shall achieve more than 99.9 per cent vaporisation of tetracontane ( $\text{CH}_3(\text{CH}_2)_{38}\text{CH}_3$ ) particles with a count median diameter larger than 50 nm and mass above 1 mg/m<sup>3</sup>, by means of heating and reduction of partial pressures of the tetracontane;
- (u) It shall achieve a solid particle penetration efficiency of at least 70 per cent for particles of 100 nm electrical mobility diameter;
- (v) It shall operate at sample pressures in the 850 to 1050 mbar range and relative pressure differences from ambient in the  $\pm 50$  mbar range.

#### 12.2.2.3. PN Internal Transfer Line

Lines that transfer the aerosol from the dilution system (TPN10) and the VPR (SPN10) to the inlet of the PNC shall meet the specifications described below:

- (a) Use internal transfer lines appropriately designed to minimise particle transport losses between the dilution system (TPN10) or the VPR (SPN10) and the inlet of the PNC;
- (b) Use internal transfer lines made of electrically conductive materials that do not react with brake aerosol components;
- (c) Select internal transfer lines with a constant inner diameter ( $d_{it}$ ) of at least 4 mm ensuring a laminar flow under all operating conditions;
- (d) The overall length of the internal transfer lines from the exit of the dilution system (TPN10) or the VPR (SPN10) to the inlet of the PNC shall not exceed 1 m;
- (e) The particles' residence time inside the internal transfer lines shall be below 1 s;
- (f) A bend may be applied to the PN internal transfer lines provided that the bending radius  $r_b$  is at least ten times the inner diameter ( $10 \cdot d_{it}$ ) of the internal transfer line.

#### 12.2.3. Particle Measurement

## 12.2.3.1. Particle Number Counter

Particle Number Counters (PNC) shall be applied for the measurement of the TPN10 and SPN10 concentrations. The testing facility shall ensure that the PNC meets the following requirements for both TPN10 and SPN10:

- (a) Operate under full flow operating conditions;
- (b) Have a counting accuracy of  $\pm 10$  per cent across the range from  $1 \text{ \#/cm}^3$  to the upper threshold of the single-particle count mode of the PNC against a traceable standard;
- (c) Have readability of at least  $0.1 \text{ \#/cm}^3$  at concentrations below  $100 \text{ \#/cm}^3$ ;
- (d) Have a linear response to particle concentrations over the full measurement range in single-particle count mode;
- (e) Have a  $t_{90}$  response time over the measured concentration range of less than 5 s;
- (f) Incorporate an internal calibration factor from the linearity calibration against a traceable reference which shall be applied to determine the PNC counting efficiency. The counting efficiency shall be reported including the calibration factor according to the specifications provided in paragraph 14.6;
- (g) The PNC calibration material shall be 4 cSt polyalphaolefin (Emery oil), soot-like particles (e.g. flame generated soot or graphite particles), or silver particles;
- (h) Have counting efficiencies at nominal particle sizes of 10 nm and 15 nm electrical mobility diameter of  $(65 \pm 15)$  per cent and above 90 per cent, respectively. These counting efficiencies may be achieved by internal (e.g. control of instrument design) or external (e.g. size pre-classification) means;
- (i) If the PNC makes use of a working liquid, it shall be replaced at the frequency specified by the instrument manufacturer.

## 12.2.3.2. PN Sampling Flow

The PN measurement system shall meet the following provisions for the regulation and measurement of the sampling flow (i.e. flow at the PN sampling probe). These apply to both TPN10 and SPN10 sampling:

- (a) The method of measuring the flow of the sampling and measurement system shall have a maximum permissible error of  $\pm 5$  per cent of the reading under all operating conditions;
- (b) Use a flow measurement device calibrated to report flow at both operating and standard conditions. To ensure an appropriate conversion to operating conditions, the temperature sensor shall have an accuracy of  $\pm 1.0 \text{ }^\circ\text{C}$  and the pressure measurements shall have a precision and accuracy of  $\pm 1.0 \text{ kPa}$ ;
- (c) The actual normalised sampling flow ( $NQ_{\text{TPN10}}$  and  $NQ_{\text{SPN10}}$ ) shall not deviate more than  $\pm 10$  per cent of the average value for the given test. Use a device with a flow control feature (e.g. critical orifice, pressure regulator, feedback controller, or other) to ensure a stable flow;
- (d) Register the actual normalised sampling flow and report it at a frequency of 1Hz in the Time-Based file. Report the average actual normalised sampling flows as specified in paragraph 13.4.;
- (e) Ensure the average isokinetic ratio during the emissions measurement section of a specific brake is between 0.60 and 1.50;

- (f) Use Equation 12.4 to calculate the average isokinetic ratio for both TPN10 and SPN10. Use the corresponding values for the isokinetic nozzle inner diameters for TPN10 and SPN10 sampling. Use the data of the average normalised tunnel flow ( $NQ$ ) and the average normalised sample flows ( $NQ_{TPN10}$  and  $NQ_{SPN10}$ ) in the Time-Based file. Report the calculated values as specified in Table 13.6. in paragraph 13.4.;
- (g) If the sampling flow or the isokinetic requirements set out in this paragraph are not met, the test shall be invalid;
- (h) The PN sampling devices shall operate continuously during the brake emissions measurement section. This includes also the cooling sections between the individual trips of the WLTP-Brake cycle where the PN sampling flow shall not be paused or bypass the main sampling line. The PN sampling devices shall operate until the post-test background verification is completed.

#### 12.2.4. PN Emissions Calculation

The testing facility shall report PN emissions in the number of particles per distance driven. The calculation of the reference (or initial) TPN10 and SPN10 emission factors for the tested brake ( $EF_{ref}$ ) follows Equations 12.11 and 12.12, respectively.

$$\text{TPN10 } EF_{ref} = 10^6 \times (\text{TPN}_{10\#} \times NQ) / V \quad (\text{Eq. 12.11})$$

$$\text{SPN10 } EF_{ref} = 10^6 \times (\text{SPN}_{10\#} \times NQ) / V \quad (\text{Eq. 12.12})$$

Where:

TPN10  $EF_{ref}$  is the number of TPN10 per distance driven for the tested brake in #/km;

SPN10  $EF_{ref}$  is the number of SPN10 per distance driven for the tested brake in #/km;

$\text{TPN}_{10\#}$  is the average normalised and PCRF-corrected TPN10 emissions in  $\#/N\text{cm}^3$  per Table 13.2.;

$\text{SPN}_{10\#}$  is the average normalised and PCRF-corrected SPN10 emissions in  $\#/N\text{cm}^3$  per Table 13.2.;

$NQ$  is the average normalised airflow in the sampling tunnel in  $N\text{m}^3/\text{h}$  per Table 13.2.;

$V$  is the average actual velocity of the WLTP-Brake cycle in km/h per Table 13.2.

- (a) Calculate the average normalised and PCRF-corrected TPN10 and SPN10 emissions from the given parameters in the Time-Based file;
- (b) Calculate the average normalised tunnel flow ( $NQ$ ) and the average velocity of the WLTP-Brake cycle ( $V$ ) over the emissions measurement section from the given parameters in the Time-Based file;
- (c) Calculate the TPN10 and SPN10  $EF_{ref}$  of the tested brake following Equations 12.11 and 12.12, respectively. Then, use the friction braking share coefficient in Table 5.1. to calculate the final TPN10 and SPN10 EF of the tested brake. Apply the friction braking share coefficient that corresponds to the vehicle type of which the parameters were used for testing the brake. Use Equations 12.13 and 12.14 for the calculation of the final TPN10 and SPN10, respectively:

$$\text{TPN10 } EF = \text{TPN10 } EF_{ref} * c \quad (\text{Eq. 12.13})$$

$$\text{SPN10 EF} = \text{SPN10 EF}_{ref} * c \quad (\text{Eq. 12.14})$$

- (d) Report the final TPN10 and SPN10 EF as specified in Table 13.6. in paragraph 13.4.;
- (e) In case the measured TPN10 or SPN10 emissions are out of the specified measurement range of the PNC device(s), the test shall be invalid.

#### 12.2.5. PN System Verification Procedures

The testing facility shall apply the following PN system check procedures to verify the whole system is fully operational:

- (a) The flow into the PNC shall have a measured value within  $\pm 5$  per cent of the PNC nominal flow rate when checked with a calibrated flow meter. Here the term 'nominal flow rate' refers to the flow rate stated in the documentation of the last calibration for the PNC. The testing facility shall perform this check every month;
- (b) A zero check on the PNC using a filter of appropriate performance at the PNC inlet shall report a concentration of  $\leq 0.2 \text{ \#/cm}^3$ . Upon removal of the filter, the PNC shall show an increase in measured concentration and a return to  $0.2 \text{ \#/cm}^3$  or less on replacement of the filter. The PNC shall not report any errors. The testing facility shall perform this check for every brake emissions test;
- (c) The PNC shall report a measured concentration of less than  $0.5 \text{ \#/cm}^3$  (without applying any PCRF correction) when a HEPA filter of at least class H13 (EN 1822:2008), or equivalent performance, is attached to the inlet of the sample conditioning system. The testing facility shall perform this check before each brake emissions test;
- (d) Before the start of each brake emissions test, the testing facility shall confirm that the measurement system indicates that the sample conditioning system has reached its correct operating temperatures.

### 12.3. Mass Loss Measurement

The mass loss of the brake under testing provides helpful information regarding the robustness and correctness of the overall test procedure. It can be used as an indicator of possible issues during the execution of the brake emissions test. The testing facility shall measure the initial and final mass of the brake assembly before and after testing. Make sure not to disrupt the brake assembly during the brake emissions test. If the same parts are used for cooling air adjustment, bedding, and emissions measurement sections, then the initial mass corresponds to the mass measured before commencing the cooling air adjustment. If a new set of parts are used after cooling air adjustment, then the initial mass corresponds to the mass measured before commencing the bedding section. In both cases, the final mass corresponds to the mass measured after the emissions measurement section. All measurements shall be carried out according to the following procedure:

- (a) Vacuum-clean the parts before conducting the measurements to remove any possible contamination;
- (b) Inspect all brake parts for burs, cracks, voids, or detachments and record accordingly. If there are not such problems proceed with the initial measurements;
- (c) Weigh each part separately with the thermocouple installed and the thermocouple connector removed (in the case of discs and drums). Report the initial mass in the Mass Measurement File;

- (d) Weigh the brake friction material including the anti-noise shims, pad-shim springs, and other elements when part of the product assembly. Report the initial masses in the Mass Measurement File;
- (e) Use a weighing scale of a resolution of at least 0.1 g or better for parts below 20 kg of total weight. Use certified calibration weights to verify the stability and the proper function of the balance every month. The microbalance shall fulfil the calibration requirements described in paragraph 14.4. It is recommended to install the weighing scale in a room with controlled air and humidity conditions of  $(22 \pm 2)$  °C and  $(45 \pm 8)$  per cent RH;
- (f) After the end of the brake emissions test, ensure the brake parts are cool down to a temperature of 30 °C or below by storing them for a maximum of 24h in a room with controlled air and humidity conditions;
- (g) After the brakes cool down, clean the parts to remove any grease or contamination before performing the final mass measurements;
- (h) Weigh the brake disc or drum and the brake pads or shoes. Report the final masses in the Mass Measurement File;
- (i) Calculate the mass loss of the disc or drum and the brake pads or shoes by subtracting the final from the initial total mass, respectively. Report the mass loss of each part in the Mass Measurement File following the instructions defined in Table 13.5.;
- (j) Calculate the overall mass loss of the brake under testing by summing the values for the individual parts calculated in (i) of this paragraph. Report the overall mass loss following the instructions defined in Table 13.5.;
- (k) Calculate the averaged weight loss emission factor by dividing the total mass loss calculated in (j) of this paragraph by the total distance driven during the brake emissions test considering all sections. The total distance shall include all iterations of the cooling air adjustment test if the same parts are used for both the cooling air adjustment and brake emissions test. Report the averaged weight loss emission factor following the instructions defined in Table 13.5.

## 13. Test Output

This section describes the four main outputs of a brake emissions test. These are summarised in the following:

- (a) Event-Based file. A detailed description of the file and the required parameters is provided in paragraph 13.1.;
- (b) Time-Based file. A detailed description of the file and the required parameters is provided in paragraph 13.2.;
- (c) Mass measurement file. A detailed description of the file and the required parameters is provided in paragraph 13.3.;
- (d) Reporting file. A detailed description of the file and the required parameters is provided in paragraph 13.4.

### 13.1. Event-Based File

The testing facility shall generate a CSV or ODS Event-Based file for the brake emissions test. The file shall include the necessary data for each brake deceleration event throughout the entire brake emissions test. This file format is agnostic to the control technology and software. Each section of the brake emissions test shall be reported in a separate tab as follows:

- (a) Tab 1 titled “Test ID – EBF – Raw Data” shall include all raw data of the testing parameters specified in this paragraph sampled or calculated by the brake dynamometer throughout the entire test;
- (b) Tab 2 titled “Test ID – EBF – Cooling” shall include the data for the parameters specified in this paragraph over the cooling adjustment section. Only data from the successful iteration of Trip #10 shall be reported in this tab when there are multiple iterations of Trip #10;
- (c) Tabs 3-7 titled “Test ID – EBF – Bedding 1-5” shall include the data for the parameters specified in this paragraph over the bedding section. Each tab shall correspond to one repetition of the WLTP-Brake cycle. Tabs 3-7 shall not include data from the soaking sections applied between the repetitions of the 5 WLTP-Brake cycles;
- (d) Tab 8 titled “Test ID – EBF – Emissions” shall include the data for the parameters specified in this paragraph over the brake emissions measurement section. Tab 8 shall not include data from the soaking sections applied between the individual trips of the WLTP-Brake cycle.

The testing facility shall continuously and automatically sample and/or calculate the parameters listed in Table 13.1. Details regarding the applied units, the number of decimals, and the sampling rate of each parameter are given in Table 13.1. Sampling rate in the context of this UN GTR is the frequency with which the automation system samples and registers the various parameters.

Regardless of the sampling rate, in the Event-Based File the parameters shall be reported for each individual brake event. The brake (or deceleration) event is defined by its start and end time. The brake event start time is the time stamp when the deceleration setpoint is above zero. The brake event end time is the time stamp when the deceleration setpoint is back to zero or a negative value. Some of the parameters reported in the Event-Based file are defined by the brake event start and end time as they represent their instantaneous values at these timestamps (i.e. Time of Stop, Stop Duration, Initial Brake Speed Measured, Release Speed Measured, Initial Brake Temperature, Final Brake Temperature). The rest of the parameters shall be averaged (distance- or time-based) over the brake event to report a unique value for each parameter. The averaging of these parameters shall be performed using the 250 Hz data sampled from 0.5 sec after the brake event start time to 0.5 sec before the brake event end time.

Table 13.1.  
**Necessary parameters for sampling and reporting at the Event-Based file of a brake emissions test**

<i>Measurand</i>	<i>Symbol</i>	<i>Unit</i>	<i>Decimals</i>	<i>Description</i>	<i>Sampling Rate</i>	<i>Column in the File</i>
Test Section	-	#	N/A	A three digits “ABC” identification code for each deceleration event. “A” represents the cycle’s serial number in a given brake emissions test (A=1 for cooling adjustment, A=2-6 for bedding, A=7 for emissions measurement). BC represents the trip’s serial number (B=01-10). It is not sampled but shall be automatically reported at the individual brake event level	N/A	A

<i>Measurand</i>	<i>Symbol</i>	<i>Unit</i>	<i>Decimals</i>	<i>Description</i>	<i>Sampling Rate</i>	<i>Column in the File</i>
Trip Stop Number	-	#	N/A	The serial number of the deceleration event within the individual trip (it can take values between 1 and 114). It is not sampled but shall be automatically reported at the individual brake event level	N/A	B
Cycle Stop Number	-	#	N/A	The serial number of the deceleration event within the WLTP-Brake cycle (can take values between 1 and 303). It is not sampled but shall be automatically reported at the individual brake event level	N/A	C
Stop Duration	$t_{\text{brake}}$	s	1	The total duration of the deceleration event. It is defined by the time at the beginning and by the time at the end of the deceleration event	250Hz	D
Time of Stop	-	hh:mm:ss	N/A	Time at the beginning of the deceleration event registered by the brake dynamometer	250Hz	E
Date of Stop	-	yyyy-mm-dd	N/A	Date at the beginning of the deceleration event registered by the brake dynamometer. It shall be automatically reported at the individual brake event level	N/A	F
Initial Brake Speed Setpoint	-	km/h	1	The nominal linear speed at the beginning of the deceleration event as defined in the WLTP-Brake cycle. It is not sampled but shall be automatically reported at the individual brake event level	N/A	G
Initial Brake Speed Measured	-	km/h	1	The actual linear speed at the beginning of the deceleration event registered by the brake dynamometer	250Hz	H
Release Speed Setpoint	-	km/h	1	The nominal linear speed at the end (release) of the deceleration event as defined in the WLTP-Brake cycle. It is not sampled but shall be automatically reported at the individual brake event level	N/A	I
Release Speed Measured	-	km/h	1	The actual linear speed at the end (release) of the deceleration event registered by the brake dynamometer	250Hz	J
Rotational Speed	$f$	rpm	1	Time-averaged rotational brake speed registered by the brake dynamometer. The rotational speed sampled during the brake event at 250Hz shall be reported at the individual brake event level as time averaged. Averaging shall be performed using the 250Hz data sampled from 0.5 sec after the brake event start time to 0.5 sec before the brake event end time	250Hz	K

<i>Measurand</i>	<i>Symbol</i>	<i>Unit</i>	<i>Decimals</i>	<i>Description</i>	<i>Sampling Rate</i>	<i>Column in the File</i>
Deceleration Rate Setpoint	-	m/s <sup>2</sup>	2	Nominal deceleration rate of the event as defined in the WLTP-Brake cycle. It is not sampled but shall be automatically reported at the individual brake event level	N/A	L
Deceleration Rate Calculated	-	m/s <sup>2</sup>	2	Deceleration rate of the given brake event as calculated from parameters in columns D, H, and J	N/A	M
Brake Torque – Distance Averaged	-	Nm	1	Distance averaged brake torque registered by the brake dynamometer. The brake torque sampled during the brake event at 250Hz shall be reported at the individual brake event level as distance averaged. Averaging shall be performed using the 250Hz data sampled from 0.5 sec after the brake event start time to 0.5 sec before the brake event end time	250Hz	N
Brake Torque – Time Averaged	T <sub>brake-avg</sub>	Nm	1	Time-averaged brake torque registered by the brake dynamometer. The brake torque sampled during the brake event at 250Hz shall be reported at the individual brake event level as time averaged. Averaging shall be performed using the 250Hz data sampled from 0.5 sec after the brake event start time to 0.5 sec before the brake event end time	250Hz	O
Brake Pressure	-	bar	2	Distance averaged brake pressure registered by the brake dynamometer. The brake pressure sampled during the brake event at 250Hz shall be reported at the individual brake event level as distance averaged. Averaging shall be performed using the 250Hz data sampled from 0.5 sec after the brake event start time to 0.5 sec before the brake event end time	250Hz	P
Friction Coefficient	μ	-	3	Distance averaged friction coefficient as a function of braking torque, effective brake radius, and the piston area. The friction coefficient calculated from these parameters shall be reported at the individual brake event level as distance averaged. Averaging shall be performed using the 250Hz data sampled from 0.5 sec after the brake event start time to 0.5 sec before the brake event end time	N/A	Q



<i>Measurand</i>	<i>Symbol</i>	<i>Unit</i>	<i>Decimals</i>	<i>Description</i>	<i>Sampling Rate</i>	<i>Column in the File</i>
Initial Brake Temperature	IBT	°C	1	Brake temperature at the beginning of the deceleration event measured as defined in paragraph 8.3.	250Hz	R
Final Brake Temperature	FBT	°C	1	Brake temperature at the end of the deceleration event measured as defined in paragraph 8.3.	250Hz	S
Peak Brake Temperature	PBT	°C	1	Peak brake temperature of the deceleration event measured as defined in paragraph 8.3.	250Hz	T
Specific Friction Work	$W_f$	J/kg	1	The actual specific friction work applied to the brake in the given deceleration event calculated from parameters in columns D, K, and O using Equation 10.1	N/A	U

### 13.2. Time-Based File

The testing facility shall generate a CSV or ODS Time-Based file for the brake emissions test. The file shall include information about specific testing parameters sampled throughout the entire brake emissions test. Each section of the brake emissions test shall be reported in a separate tab as follows:

- (a) Tab 1 titled “Test ID – TBF – Raw Data” shall include all raw data sampled or calculated by the brake dynamometer, the sampling instruments, and the measurement devices as specified in this paragraph;
- (b) Tab 2 titled “Test ID - TBF - Pre-test BG” shall include the reported data for the parameters specified in this paragraph over the pre-test background verification procedure. Although the template is the same as for other sections of the brake emissions test, the testing facility is requested to report only the relevant parameters necessary for the calculation of the background emissions as specified in paragraph 7.2.2;
- (c) Tab 3 titled “Test ID – TBF – Cooling” shall include the reported data for the parameters specified in this paragraph over the cooling adjustment section. Only data from the successful iteration of Trip #10 shall be reported in this tab when there are multiple iterations of Trip #10;
- (d) Tabs 4-8 titled “Test ID – TBF – Bedding 1-5” shall include the reported data for the parameters specified in this paragraph over the bedding section. Each tab shall correspond to one repetition of the WLTP-Brake cycle. Tabs 3-7 shall not include data from the soaking sections applied between the repetitions of the 5 WLTP-Brake cycles;
- (e) Tab 9 titled “Test ID – TBF – Emissions” shall include the reported data for the parameters specified in this paragraph over the brake emissions measurement section. Tab 8 shall not include data from the soaking sections applied between the individual trips of the WLTP-Brake cycle;
- (f) Tab 10 titled “Test ID - TBF - Post-test BG” shall include the reported data for the parameters specified in this paragraph over the post-test background verification procedure. Although the template is the same as for other sections of the brake emissions test, the testing facility is requested to report only the relevant parameters necessary for the calculation of the background emissions as specified in paragraph 7.2.2.

The testing facility shall continuously and automatically sample and/or calculate the parameters listed in Table 13.2. Details regarding the applied

units, the number of decimals, and the sampling rate of each parameter are given in Table 13.2. Sampling rate in the context of this UN GTR is the frequency with which the automation system samples and registers the various parameters.

Regardless of the sampling rate, in the Time-Based File the parameters shall be reported at 1Hz. Therefore, the sampled values are averaged to calculate the 1Hz reported values. Table 13.2. also provides a short description of each parameter and the symbol used throughout the text.

Table 13.2.

**Necessary parameters for sampling and reporting at the Time-Based file of a brake emissions test**

<i>Measurand</i>	<i>Symbol</i>	<i>Unit</i>	<i>Decimals</i>	<i>Description</i>	<i>Sampling Rate</i>	<i>Column in the File</i>
Timestamp	-	sec	0	Timestamp in the brake emissions test	10Hz	A
Linear Speed Nominal	$V_{set}$	km/h	1	Nominal linear speed at the given point in time as defined in the WLTP-Brake cycle. It is not sampled but shall be reported at 1Hz	N/A	B
Linear Speed Actual	V	km/h	1	Actual linear speed registered by the brake dynamometer at the given point in time	10Hz	C
Driven Distance	d	km	1	Total distance driven in the cycle until the given point in time	10Hz	D
Deceleration Rate	$\alpha$	m/s <sup>2</sup>	2	Deceleration rate registered by the brake dynamometer at the given point in time	10Hz	E
Brake Torque	$\tau_{brake}$	N·m	1	Brake torque registered by the brake dynamometer at the given point in time	10Hz	F
Brake Pressure	$P_{brake}$	bar	2	Brake pressure registered by the brake dynamometer at the given point in time	10Hz	G
Friction Coefficient	$\mu$	-	3	Instantaneous friction coefficient calculated at the given point in time	10Hz	H
Brake Temperature	$T_{brake}$	°C	1	Brake temperature at the given point in time	10Hz	I
Cooling Airflow Set	$Q_{set}$	m <sup>3</sup> /h	1	Set (nominal) cooling airflow for the given brake emissions test. It is not sampled but shall be reported at 1Hz	N/A	J
Cooling Airflow Actual	Q	m <sup>3</sup> /h	1	Measured cooling airflow at the given point in time	10Hz	K
Cooling Airflow Actual Normalised	NQ	Nm <sup>3</sup> /h	1	Normalised cooling airflow at standard conditions at the given point in time	10Hz	L
Cooling Airspeed Actual	U	km/h	1	Cooling airspeed at the given point in time (measured or calculated)	10Hz	M
Cooling Air Temperature	T	°C	1	Temperature of the cooling air at the given point in time	10Hz	N
Cooling Air Relative Humidity	RH	%	1	Relative humidity of the cooling air at the given point in time	10Hz	O
Cooling Air Absolute Humidity	AH	mg/g	1	Absolute humidity of the cooling air at the given point in time	10Hz	P

<i>Measurand</i>	<i>Symbol</i>	<i>Unit</i>	<i>Decimals</i>	<i>Description</i>	<i>Sampling Rate</i>	<i>Column in the File</i>
Cooling Air Pressure	P	kPa	1	Pressure of the cooling air at the given point in time	10Hz	Q
PM <sub>2.5</sub> Sampling Flow Set	Q <sub>PM2.5-set</sub>	l/min	2	Set (nominal) PM <sub>2.5</sub> sampling flow for the given brake emissions test. It is not sampled but shall be reported at 1Hz	N/A	R
PM <sub>2.5</sub> Sampling Flow Actual	Q <sub>PM2.5</sub>	l/min	2	PM <sub>2.5</sub> sampling flow measured at the given point in time	10Hz	S
PM <sub>2.5</sub> Sampling Flow Actual Normalised	NQ <sub>PM2.5</sub>	l/min	2	Normalised PM <sub>2.5</sub> sampling flow at standard conditions at the given point in time	10Hz	T
PM <sub>10</sub> Sampling Flow Set	Q <sub>PM10-set</sub>	l/min	2	Set (nominal) PM <sub>10</sub> sampling flow for the given brake emissions test. It is not sampled but shall be reported at 1Hz	N/A	U
PM <sub>10</sub> Sampling Flow Actual	Q <sub>PM10</sub>	l/min	2	PM <sub>10</sub> sampling flow measured at the given point in time	10Hz	V
PM <sub>10</sub> Sampling Flow Actual Normalised	NQ <sub>PM10</sub>	l/min	2	Normalised PM <sub>10</sub> sampling flow at standard conditions at the given point in time	10Hz	W
TPN10 Sampling Flow Actual Normalised	NQ <sub>TPN10</sub>	l/min	2	TPN10-related sampling flow measured at the given point in time and reported at standard conditions. The testing facility shall specify if the sampling rate is different than the nominal	10Hz	X
TPN10 - Average PCRF	f <sub>r-TPN10</sub>	-	1	Arithmetic average particle concentration reduction factor for the TPN10 measurement	10Hz	Y
TPN10 Concentration Normalised - PCRF Corrected	TPN <sub>10#</sub>	#/Ncm <sup>3</sup>	1	TPN10 normalised concentration at standard conditions measured by the PNC and corrected for the PCRF at the given point in time	10Hz	Z
SPN10 Sampling Flow Actual Normalised	NQ <sub>SPN10</sub>	l/min	2	SPN10-related sampling flow measured at the given point in time and reported at standard conditions. The testing facility shall specify if the sampling rate is different than the nominal	10Hz	AA
SPN10 - Average PCRF	f <sub>r-SPN10</sub>	-	1	Arithmetic average particle concentration reduction factor for the SPN10 measurement	10Hz	AB
SPN10 Concentration Normalised - PCRF Corrected	SPN <sub>10#</sub>	#/Ncm <sup>3</sup>	1	SPN10 normalised concentration at standard conditions measured by the PNC and corrected for the PCRF at the given point in time	10Hz	AC

### 13.3. Mass Measurement File

The testing facility shall generate a CSV or ODS Mass Measurement file for the entire test. The file shall include information about weighing the filters as specified in paragraph 12.1. as well as for weighing the brake parts as specified in paragraph 12.3. PM mass data shall be reported in one tab as specified in Table 13.3. Information about the reference filters shall be reported in a different tab as specified in Table 13.4. Finally, information regarding mass loss of the brake parts shall be reported in a separate tab as specified in Table 13.5.

#### 13.3.1. PM Measurement Data

The testing facility shall report and calculate the parameters related to the PM mass measurement listed in Table 13.3. Details regarding the applied units and the number of decimals of each parameter are provided in Table 13.3. Additionally, a short description of each parameter is given. PM weighing data shall be reported in the tab titled “Test ID – PMMF – PM Mass” of the Mass Measurement file.

Table 13.3.

#### Necessary parameters related to the PM mass measurement procedure for reporting at the Mass Measurement file of a brake emissions test

<i>Measurand</i>	<i>Unit</i>	<i>Decimals</i>	<i>Description</i>	<i>Column in the File</i>
Test ID	#	N/A	A unique code that allows the testing facility to identify the tested brake. Shall be the same as in “Test ID” in Table 13.6.	A
Filter Material	#	N/A	Specifies the type of filter used for PM sampling per paragraph 12.1.3.2.	B
PM <sub>2.5</sub>	#	N/A	Specifies whether the input data refer to PM <sub>2.5</sub> sampling and measurement	C
PM <sub>10</sub>	#	N/A	Specifies whether the input data refer to PM <sub>10</sub> sampling and measurement	D
Weighing Date	yyyy-mm-dd	N/A	Date on which weighing of the unloaded filter takes place	E
Weighing Time	hh:mm	N/A	Time at which weighing of the unloaded filter takes place	F
Stabilisation time before weighing	hh:mm	N/A	Stabilisation time of the unloaded filter before being weighed and used for sampling per paragraph 12.1.4.	G
Elapsed time from weighing to test start	hh:mm	N/A	Elapsed time from weighing the unloaded filter to the beginning of the emissions test per paragraph 12.1.4.	H
Unloaded Measurement 1	mg	3	Weight of the unloaded filter measured at the first weighing per paragraph 12.1.4.	I
Unloaded Measurement 2	mg	3	Weight of the unloaded filter measured at the second weighing per paragraph 12.1.4.	J
Unloaded Measurement 3 (if necessary)	mg	3	Weight of the unloaded filter measured at the third weighing per paragraph 12.1.4. – This measurement is necessary only if the deviation between the first two measurements is higher than 30 µg	K
Unloaded Measurement 4 (if necessary)	mg	3	Weight of the unloaded filter measured at the fourth weighing per paragraph 12.1.4. – This measurement is necessary only if the deviation between the first two measurements is higher than 30 µg	L
Mean Value	mg	3	The average weight of the unloaded filter as specified in paragraph 12.1.4. (P <sub>e</sub> (Uncorrected))	M

<i>Measurand</i>	<i>Unit</i>	<i>Decimals</i>	<i>Description</i>	<i>Column in the File</i>
Mean Value – Corrected	mg	3	The corrected average weight of the unloaded filter after applying the buoyancy correction per paragraph 12.1.4. ( $Pe_{(Corrected)}$ )	N
Ambient Air Temperature	°C	1	Weighing room temperature – Report the average temperature of the room during the last hour before the weighing procedure	O
Ambient Air Relative Humidity	%	1	Weighing room relative humidity – Report the average relative humidity of the room during the last hour before the weighing procedure	P
Weighing Date	yyyy-mm-dd	N/A	Date on which weighing of the loaded filter takes place	Q
Weighing Time	hh:mm	N/A	Time at which weighing of the loaded filter takes place	R
Stabilisation time before weighing	hh:mm	N/A	Stabilisation time of the loaded filter after sampling and before being weighed per paragraph 12.1.4.	S
Elapsed time from end test to weighing	hh:mm	N/A	Elapsed time from the end of the emissions tests to weighing the loaded filter per paragraph 12.1.4.	T
Loaded Measurement 1	mg	3	Weight of the loaded filter measured at the first weighing per paragraph 12.1.4.	U
Loaded Measurement 2	mg	3	Weight of the loaded filter measured at the second weighing per paragraph 12.1.4.	V
Loaded Measurement 3 (if necessary)	mg	3	Weight of the loaded filter measured at the third weighing per paragraph 12.1.4. – This measurement is necessary only if the deviation between the first two measurements is higher than 30 µg	W
Loaded Measurement 4 (if necessary)	mg	3	Weight of the loaded filter measured at the fourth weighing per paragraph 12.1.4. – This measurement is necessary only if the deviation between the first two measurements is higher than 30 µg	X
Mean Value	mg	3	The average weight of the loaded filter as specified in paragraph 12.1.4. ( $Pe_{(Uncorrected)}$ )	Y
Mean Value – Corrected	mg	3	The corrected average weight of the loaded filter after applying the buoyancy correction per paragraph 12.1.4. ( $Pe_{(Corrected)}$ )	Z
Ambient Air Temperature	°C	1	Weighing room temperature – Report the average temperature of the room during the last hour before the weighing procedure	AA
Ambient Air Relative Humidity	%	1	Weighing room relative humidity – Report the average temperature of the room during the last hour before the weighing procedure	AB
Loaded Mass	mg	3	$Pe_{(2.5)}$ and $Pe_{(10)}$ : The difference between the mean corrected value of the loaded and unloaded filter – Subtract the value in column M by the value in column X	AC

### 13.3.2. Reference Filters Data

The testing facility shall report the parameters related to the reference filters used for the PM mass measurement of a given brake. Details regarding the parameters, the applied units, and the number of decimals of each parameter

are provided in Table 13.4. The reference filter data shall be reported in the tab titled “Test ID – PMMF – Reference” of the Mass Measurement file.

Table 13.4.

**Necessary parameters related to the reference filters used at the PM mass measurement procedure for reporting at the Mass Measurement file of a brake emissions test**

<i>Measurand</i>	<i>Unit</i>	<i>Decimals</i>	<i>Description</i>	<i>Column in the File</i>
Test ID	#	N/A	A unique code that allows the testing facility to identify the tested brake – Shall be the same as in “Test ID” in Table 13.6.	A
Filter Material	#	N/A	Type of filter used as reference per paragraph 12.1.4. – Shall be the same as the filter used in the emissions test	B
Weighing Date Beginning	yyyy-mm-dd	N/A	Date on which the initial weighing of the reference filter takes place	C
Weighing Time Beginning	hh:mm	N/A	Time at which initial weighing of the reference filter takes place	D
Measurement Beginning	mg	3	Weight of the reference filter measured at the beginning as defined in paragraph 12.1.4.	E
Ambient Air Temperature	°C	1	Weighing room temperature – Average temperature of the room during the last hour before the weighing procedure	F
Ambient Air Relative Humidity	%	1	Weighing room relative humidity – Average RH of the room during the last hour before the weighing procedure	G
Weighing Date End	yyyy-mm-dd	N/A	Date on which the final weighing of the reference filter takes place	H
Weighing Time End	hh:mm	N/A	Time at which the final weighing of the reference filter takes place	I
Measurement End	mg	3	Weight of the reference filter measured at the end as defined in paragraph 12.1.4.	J
Ambient Air Temperature	°C	1	Weighing room temperature – Average temperature of the room during the last hour before the weighing procedure	K
Ambient Air Relative Humidity	%	1	Weighing room relative humidity – Average RH of the room during the last hour before the weighing procedure	L
Mass Difference	mg	3	Difference between the weighted value of the reference filter at the beginning and the end of the testing campaign – Subtract the value in column E by the value in column L	M

13.3.3. Mass Loss Measurement Data

The testing facility shall report the parameters related to the total mass loss of the tested brake in a separate tab as specified in paragraph 12.3. Details regarding the parameters, the applied units, and the number of decimals of each parameter are provided in Table 13.5. The mass loss measurement data shall be reported in the tab titled “Test ID – PMMF –Mass Loss” of the Mass Measurement file.

Table 13.5.

**Necessary parameters related to the total mass loss of the brake for reporting at the Mass Measurement file of a brake emissions test**

<i>Measurand</i>	<i>Unit</i>	<i>Decimals</i>	<i>Description</i>	<i>Column in the File</i>
Test ID	#	N/A	A unique code that allows the testing facility to identify the tested brake – Shall be the same as in “Test ID” in Table 13.6.	A
Disc Brake	#	N/A	Specifies whether the testing brake couple consists of a disc and a pair of pads	B
Drum Brake	#	N/A	Specifies whether the testing brake couple consists of a drum and a pair of shoes	C
Initial Weighings Inner pad / Leading shoe	g	3	Weight of the inner pad or the leading shoe before the beginning of the overall brake emissions test - Leading shoe is the first shoe after the wheel cylinder in the direction of the wheel rotation	D
Initial Weighings Outer pad / Trailing shoe	g	3	Weight of the outer pad or the trailing shoe before the beginning of the overall testing procedure - Trailing shoe is the shoe behind the wheel cylinder in the direction of the wheel rotation	E
Initial Weighings Disc / Drum	g	3	Weight of the disc or drum before the beginning of the overall testing procedure	F
Final Weighings Inner pad / Leading shoe	g	3	Weight of the inner pad or the leading shoe after the end of the overall testing procedure	G
Final Weighings Outer pad / Trailing shoe	g	3	Weight of the outer pad or the trailing shoe after the end of the overall testing procedure	H
Final Weighings Disc / Drum	g	3	Weight of the disc or drum after the end of the overall testing procedure	I
Mass Loss Inner pad / Leading shoe	mg	3	Difference between the weighted value of the inner pad or the leading shoe at the beginning and the end of the overall testing procedure – Subtract the value in column D from the value in column G	J
Mass Loss Outer pad / Trailing shoe	mg	3	Difference between the weighted value of the outer pad or the trailing shoe at the beginning and the end of the overall testing procedure – Subtract the value in column E from the value in column H	K
Mass Loss Disc / Drum	mg	3	Difference between the weighted value of the disc or the drum at the beginning and the end of the overall testing procedure – Subtract the value in column F from the value in column I	L
Mass Loss Total	mg	3	Total mass loss of the brake assembly during the overall testing procedure – Add the values in columns J, K, and L	M
Total Distance	km	1	Total distance covered during the entire brake emissions test including all sections (and all Trip #10 iterations during the cooling adjustment section, if applicable)	N
Mass Loss Rate Averaged	mg/km	1	Averaged mass loss rate of the brake assembly during the overall testing procedure – Divide the values in columns M/N	O

#### 13.4. Test Report File

The testing facility shall create a unique, complete, and traceable dataset as an input file for the generation of the test report for the specific brake under testing. Table 13.6. contains all the necessary information to include in the

report. All information in the report shall be correlated to the specific brake.  
The testing facility shall submit the report in a \*.pdf or equivalent format.

Table 13.6.

**Testing parameters to report after a brake particle emissions test**

<i>No.</i>	<i>Paragraph</i>	<i>Parameters and Inputs</i>	<i>Short description</i>	<i>Unit</i>
1	8.1.1.	Brake emissions test ID	A unique code attributed by the testing facility to the brake emissions test for the brake under testing – this value is used in all output files	-
2	8.1.1.	Vehicle make and model	Report vehicle make and model where the brake under testing is mounted	-
3	3.7.	Vehicle type	Report vehicle type where the brake under testing is mounted	-
	5.2.	Friction braking share coefficient	Report the vehicle friction braking share coefficient where the brake under testing is mounted	-
5	8.1.1.	Axle (front or rear)	Report the axle position on the vehicle for the brake under testing (FA or RA)	-
6	8.1.1.	Brake orientation (mounting position in the vehicle)	Report the location of the brake under testing on the vehicle, right-hand corner or left-hand corner (RHC or RLC)	-
7	8.1.1.	Vehicle test mass	Report the vehicle mass simulated on the brake dynamometer during all sections of the brake emissions test ( $M_{veh}$ ). In the case of non-friction braking, report the $M_{veh}$ of the brake emissions family parent as applied during the brake emissions test	kg
8	8.1.1.	Brake force distribution	Report the ratio of the braking force on the brake's under testing axle and the total braking force on the vehicle (FAF or RAF). In the case of non-friction braking, report the FAF or RAF of the brake emissions family parent as applied during the brake emissions test	%
9	8.4.1.	Fixture style	Report the style of the support fixture of the brake assembly (L0-U or L0-P)	-
10	8.1.1.	Part number for the disc or drum	Report the code labelled by the brake manufacturer on the disc/drum	#
11	8.1.1.	Part number for the friction material	Report the code labelled by the friction manufacturer on the pads/shoes	#
12	8.1.1.	Nominal wheel load	Calculate and report the nominal wheel load of the brake under testing ( $WL_{n-f}$ or $WL_{n-r}$ ) following Equation 8.1. In the case of non-friction braking, use the parameters of the brake emissions family parent to calculate and report the nominal wheel load	kg
13	8.1.1.	Test (or applied) wheel load	Calculate and report the test wheel load applied on the brake dynamometer ( $WL_{t-f}$ or $WL_{t-r}$ ) following Equation 8.2. In the case of non-friction braking, use the parameters of the brake emissions family parent to calculate and report the test wheel load	kg
14	8.1.1.	Tyre dynamic rolling radius	Report the tyre dynamic rolling radius related to the brake under testing ( $r_R$ )	mm
15	8.1.1.	Brake effective radius	Report the effective radius of the brake under testing ( $r_{eff}$ )	mm
16	8.1.1.	Brake nominal inertia	Calculate and report the nominal moment of inertia for the brake under testing ( $I_n$ ) following Equation 8.3. In the case of non-friction braking, use the parameters of the brake emissions family parent to calculate and report the nominal moment of inertia	kg·m <sup>2</sup>
17	8.1.1.	Brake Test (or applied) inertia	Calculate and report the moment of inertia applied on the brake dynamometer during testing ( $I_t$ ) following Equation 8.4. In the	kg·m <sup>2</sup>



No.	Paragraph	Parameters and Inputs	Short description	Unit
			case of non-friction braking, use the parameters of the brake emissions family parent to calculate and report the moment of inertia applied on the brake dynamometer during testing	
18	8.1.1.	Disc/Drum outer diameter	Report the outer diameter of the brake under testing	mm
19	8.1.1.	Disc mass	Report the actual mass of the unused disc to allocate the brake to a nominal front wheel load to a disc mass group	kg
20	8.1.1.	Number of pistons per side	Report the number of pistons on one side of the brake calliper	#
21	8.1.1.	Piston Mean (or hydraulic) Diameter	Report the diameter of the piston of the brake under testing following Equation 8.5	mm
22	8.1.1.	Brake calliper or brake drum efficiency (if applicable)	Report the efficiency to account for friction losses, piston travel, etc. if specified by the brake manufacturer	%
23	8.1.1.	Threshold pressure	Report the minimum pressure to overcome internal resistance before the onset of brake torque	kPa
24	8.1.1.	Brake runout limit	Report the maximum movement allowed for the brake under testing in a direction normal to the friction contact surface when installed on the brake fixture	µm
25	7.2.	Minimum operational flow of the system	Report the minimum cooling airflow that the testing facility layout can achieve while fulfilling all relevant cooling air conditioning and measurement requirements defined in this UN GTR	m <sup>3</sup> /h
26	7.2.	Maximum operational flow of the system	Report the maximum cooling airflow that the testing facility layout can achieve while fulfilling all relevant cooling air conditioning and measurement requirements defined in this UN GTR	m <sup>3</sup> /h
27	7.2.1.1.	Average cooling air temperature – Cooling adjustment section	Calculate and report the average cooling air temperature measured during the successful iteration of the cooling adjustment section. Use the 1Hz data of the parameter “Cooling Air Temperature” in the Time-Based File to calculate the average over Trip #10	°C
28	7.2.1.1.	Average cooling air temperature – Bedding section	Calculate and report the average cooling air temperature measured during the bedding section. Report the average cooling air temperature for all five WLTP-Brake cycles separately. Use the 1Hz data of the parameter “Cooling Air Temperature” in the Time-Based File to calculate the averages over the 5 WLTP-Brake cycles	°C
29	7.2.1.1.	Average cooling air temperature – Emissions measurement section	Calculate and report the average cooling air temperature measured during the emissions measurement section. Use the 1Hz data of the parameter “Cooling Air Temperature” in the Time-Based File to calculate the average over the WLTP-Brake cycle	°C
30	7.2.1.1.	Average cooling air temperature – Overall compliance	Verify that all parts of the test fulfil the specifications for the average cooling air temperature defined in this UN GTR	Y/N
31	7.2.1.1.	Instantaneous air temperature violations – Cooling adjustment section	Calculate and report the percentage of the instantaneous cooling air temperature readings (1Hz) with a value lower than 18 °C or higher than 28 °C during the successful iteration of the cooling adjustment section. Use the 1Hz data of the parameter “Cooling Air Temperature” in the Time-Based File to calculate the number of such occurrences and their percentage over Trip #10	%

No.	Paragraph	Parameters and Inputs	Short description	Unit
32	7.2.1.1.	Instantaneous air temperature violations – Bedding section	Calculate and report the percentage of the instantaneous cooling air temperature readings (1Hz) with a value lower than 18 °C or higher than 28 °C during the bedding section. Report the percentage for all five WLTP-Brake cycles separately. Use the 1Hz data of the parameter “Cooling Air Temperature” in the Time-Based File to calculate the number of such occurrences and their percentage over the 5 WLTP-Brake cycles	%
33	7.2.1.1.	Instantaneous air temperature violations – Emissions measurement section	Calculate and report the percentage of the instantaneous cooling air temperature readings (1Hz) with a value lower than 18 °C or higher than 28 °C during the emissions measurement section. Use the 1Hz data of the parameter “Cooling Air Temperature” in the Time-Based File to calculate the number of such occurrences and their percentage over the WLTP-Brake cycle	%
34	7.2.1.1.	Instantaneous cooling air temperature – Overall compliance	Verify that all parts of the test fulfil the specifications for the instantaneous cooling air temperature defined in this UN GTR	Y/N
35	7.2.1.2.	Average cooling air relative humidity – Cooling adjustment section	Calculate and report the average cooling air relative humidity measured during the successful iteration of the cooling adjustment section. Use the 1Hz data of the parameter “Cooling Air Relative Humidity” in the Time-Based File to calculate the average over Trip #10	%
36	7.2.1.2.	Average cooling air relative humidity – Bedding section	Calculate and report the average cooling air relative humidity measured during the bedding section. Report the average cooling air relative humidity for all five WLTP-Brake cycles separately. Use the 1Hz data of the parameter “Cooling Air Relative Humidity” in the Time-Based File to calculate the averages over the 5 WLTP-Brake cycles	%
37	7.2.1.2.	Average cooling air relative humidity – Emissions measurement section	Calculate and report the average cooling air relative humidity measured during the emissions measurement section. Use the 1Hz data of the parameter “Cooling Air Relative Humidity” in the Time-Based File to calculate the average over the WLTP-Brake cycle	%
38	7.2.1.2.	Average cooling air relative humidity – Overall compliance	Verify that all parts of the test fulfil the specifications for the average cooling air relative humidity defined in this UN GTR	Y/N
39	7.2.1.2.	Instantaneous air relative humidity violations – Cooling adjustment section	Calculate and report the percentage of the instantaneous cooling air relative humidity readings (1Hz) with a value lower than 20 per cent or higher than 80 per cent during the successful iteration of the cooling adjustment section. Use the 1Hz data of the parameter “Cooling Air Relative Humidity” in the Time-Based File to calculate the number of such occurrences and their percentage over Trip #10	%
40	7.2.1.2.	Instantaneous air relative humidity violations – Bedding section	Calculate and report the percentage of the instantaneous cooling air relative humidity readings (1Hz) with a value lower than 20 per cent or higher than 80 per cent during the bedding section. Report the percentage for all five WLTP-Brake cycles separately. Use the 1Hz data of the parameter “Cooling Air	%

No.	Paragraph	Parameters and Inputs	Short description	Unit
			Relative Humidity” in the Time-Based File to calculate the number of such occurrences and their percentage over the 5 WLTP-Brake cycles	
41	7.2.1.2.	Instantaneous air relative humidity violations – Emissions measurement section	Calculate and report the percentage of the instantaneous cooling air relative humidity readings (1Hz) with a value lower than 20 per cent or higher than 80 per cent during the emissions measurement section. Use the 1Hz data of the parameter “Cooling Air Relative Humidity” in the Time-Based File to calculate the average over the WLTP-Brake cycle	%
42	7.2.1.2.	Instantaneous cooling air relative humidity – Overall compliance	Verify that all parts of the test fulfil the specifications for the instantaneous cooling air relative humidity defined in this UN GTR	Y/N
43	7.2.1.2.	Average cooling air absolute humidity – Cooling adjustment section	Calculate and report the average cooling air absolute humidity measured during the successful iteration of the cooling adjustment section. Use the 1Hz data of the parameter “Cooling Air Absolute Humidity” in the Time-Based File to calculate the average over Trip #10	mg H <sub>2</sub> O/g dry air
44	7.2.1.2.	Average cooling air absolute humidity – Bedding section	Calculate and report the average cooling air absolute humidity measured during the bedding section. Report the average cooling air relative humidity for all five WLTP-Brake cycles separately. Use the 1Hz data of the parameter “Cooling Air Absolute Humidity” in the Time-Based File to calculate the averages over the 5 WLTP-Brake cycles	mg H <sub>2</sub> O/g dry air
45	7.2.1.2.	Average cooling air absolute humidity – Emissions measurement section	Calculate and report the average cooling air absolute humidity measured during the emissions measurement section. Use the 1Hz data of the parameter “Cooling Air Absolute Humidity” in the Time-Based File to calculate the average over the WLTP-Brake cycle	mg H <sub>2</sub> O/g dry air
46	7.2.1.2.	Average cooling air absolute humidity – Overall compliance	Verify that all parts of the test fulfil the specifications for the average cooling air absolute humidity defined in this UN GTR	Y/N
47	7.2.2.1.	Cooling air filtering – Overall compliance	Verify that the cooling air entering the system complies with the filtering specifications defined in this UN GTR	Y/N
48	7.2.2.2.1.	System background verification – TPN10 at minimum operational airflow	Report the TPN10 background concentration of the setup measured at the minimum operational airflow	#/Ncm <sup>3</sup>
49	7.2.2.2.1.	System background verification – SPN10 at minimum operational airflow	Report the SPN10 background concentration of the setup measured at the minimum operational airflow	#/Ncm <sup>3</sup>
50	7.2.2.2.1.	System background verification – TPN10 at maximum operational airflow	Report the TPN10 background concentration of the setup measured at the maximum operational airflow	#/Ncm <sup>3</sup>
51	7.2.2.2.1.	System background verification – SPN10 at maximum operational airflow	Report the SPN10 background concentration of the setup measured at the maximum operational airflow	#/Ncm <sup>3</sup>
52	7.2.2.2.3.	System background verification – Overall compliance	Verify that the TPN10 and SPN10 background concentrations measured at different airflows are below the maximum allowed limit defined in point (c) of paragraph 7.2.2.2.3.	Y/N

No.	Paragraph	Parameters and Inputs	Short description	Unit
53	7.2.2.2.2.	Test level background verification – TPN10 PCRf setting	Report the certified value of the PCRf-setting applied during the pre- and post-test background verification for TPN10	#
54	7.2.2.2.2.	Test level background verification – SPN10 PCRf setting	Report the certified value of the PCRf-setting applied during the pre- and post-test background verification for SPN10	#
55	7.2.2.2.2.	Pre-test background – TPN10 concentration	Calculate and report the TPN10 background concentration measured during the pre-test background verification (TPN10 <sub>b#</sub> ). Use the 1Hz data of the parameter “TPN10 Concentration Normalized - PCRf Corrected” in the Time-Based File (Pre-test Background) to calculate the 5-minutes average as described in 7.2.2.2.2. (d)	#/Ncm <sup>3</sup>
56	7.2.2.2.2.	Pre-test background – SPN10 concentration	Calculate and report the SPN10 background concentration measured during the pre-test background verification (SPN10 <sub>b#</sub> ). Use the 1Hz data of the parameter “SPN10 Concentration Normalized - PCRf Corrected” in the Time-Based File (Pre-test Background) to calculate the 5-minutes average as described in 7.2.2.2.2. (d)	#/Ncm <sup>3</sup>
57	7.2.2.2.2.	Post-test background – TPN10 concentration	Calculate and report the TPN10 background concentration measured during the post-test background verification (TPN10 <sub>b#</sub> ). Use the 1Hz data of the parameter “TPN10 Concentration Normalized - PCRf Corrected” in the Time-Based File (Post-test Background) to calculate the 5-minutes average as described in 7.2.2.2.2. (h)	#/Ncm <sup>3</sup>
58	7.2.2.2.2.	Post-test background – SPN10 concentration	Calculate and report the SPN10 background concentration measured during the post-test background verification (SPN10 <sub>b#</sub> ). Use the 1Hz data of the parameter “SPN10 Concentration Normalized - PCRf Corrected” in the Time-Based File (Post-test Background) to calculate the 5-minutes average as described in 7.2.2.2.2. (h)	#/Ncm <sup>3</sup>
59	7.2.2.2.3.	Test level background verification – Overall compliance	Verify that the TPN10 and SPN10 background concentrations measured at the airflow setting defined for the brake under testing are below the maximum permissible limit defined in point (c) of paragraph 7.2.2.2.3.	Y/N
60	7.2.2.2.4.	Pre-test background – TPN10 number per distance	Calculate and report the TPN10 background measured during the pre-test background verification in # per distance travelled following Equation 7.1	#/km
61	7.2.2.2.4.	Pre-test background – SPN10 number per distance	Calculate and report the SPN10 background measured during the pre-test background verification in # per distance travelled following Equation 7.2	#/km
62	7.2.2.2.4.	Post-test background – TPN10 number per distance	Calculate and report the TPN10 background measured during the post-test background verification in # per distance travelled following Equation 7.1	#/km
63	7.2.2.2.4.	Post-test background – SPN10 number per distance	Calculate and report the SPN10 background measured during the post-test background verification in # per distance travelled following Equation 7.2	#/km
64	7.2.3.	Airflow measurement device – Overall compliance	Verify the compliance of the airflow measurement element with all the requirements defined in 7.2.3. (a)-(h)	Y/N
65	7.2.3.	Cooling airflow – Nominal (or set) value	Report the nominal (or set) cooling airflow for the brake under testing (Q <sub>set</sub> )	m <sup>3</sup> /h

No.	Paragraph	Parameters and Inputs	Short description	Unit
66	7.2.3.	Cooling airflow – Nominal (or set) value	Verify that the same nominal cooling airflow has been applied during all brake emissions test sections	Y/N
67	7.2.3.	Cooling airflow – Average value (cooling adjustment section)	Calculate and report the average measured cooling airflow during the cooling adjustment section. Use the 1Hz data of the parameter “Cooling Airflow Actual” in the Time-Based File to calculate the average over Trip #10. In the case of multiple iterations of the cooling adjustment section, report only the one that resulted in the definition of the $Q_{set}$	m <sup>3</sup> /h
68	7.2.3.	Cooling airflow – Difference with the nominal flow (cooling adjustment section)	Calculate and report the per cent difference between the average measured cooling airflow and the nominal cooling airflow during the cooling adjustment section	%
69	7.2.3.	Cooling airflow – Average normalized value (cooling adjustment section)	Calculate and report the average normalized measured cooling airflow during the cooling adjustment section. Use the 1Hz data of the parameter “Cooling Airflow Actual Normalized” in the Time-Based File to calculate the average over Trip #10. In the case of multiple iterations of the cooling adjustment section, report only the one that resulted in the definition of the $Q_{set}$	Nm <sup>3</sup> /h
70	7.2.3.	Cooling airspeed – Average value (cooling adjustment section)	Calculate in the Time-Based File the instantaneous cooling airspeed during the cooling adjustment section following Equation 7.3. Calculate and report the average cooling airspeed during the cooling adjustment section. Use the 1Hz data of the parameter “Cooling Airspeed Actual” in the Time-Based File to calculate the average over Trip #10. In the case of multiple iterations of the cooling adjustment section, report only the one that resulted in the definition of the $Q_{set}$	km/h
71	7.2.3.	Cooling airflow – Average value (bedding section)	Calculate and report the average measured cooling airflow during the bedding section. Report the average measured cooling airflow for all five WLTP-Brake cycles. Use the 1Hz data of the parameter “Cooling Airflow Actual” in the Time-Based File to calculate the averages over the 5 WLTP-Brake cycles.	m <sup>3</sup> /h
72	7.2.3.	Cooling airflow – Difference with the nominal flow (bedding section)	Calculate and report the per cent difference with the nominal cooling airflow during the bedding section. Report the per cent difference for all five WLTP-Brake cycles	%
73	7.2.3.	Cooling airflow – Average normalized value (bedding section)	Calculate and report the average normalized measured cooling airflow during the bedding section. Report the average normalized measured cooling airflow for all five WLTP-Brake cycles. Use the 1Hz data of the parameter “Cooling Airflow Actual Normalized” in the Time-Based File to calculate the averages over the 5 WLTP-Brake cycles	Nm <sup>3</sup> /h
74	7.2.3.	Cooling airspeed – Average value (bedding section)	Calculate and report in the Time-Based File the instantaneous cooling airspeed during the bedding section following Equation 7.3. Calculate and report the average cooling airspeed during the bedding section for all WLTP-Brake cycles. Use the 1Hz data of the parameter “Cooling Airspeed Actual” in the Time-Based File to calculate the averages over the 5 WLTP-Brake cycles	km/h

No.	Paragraph	Parameters and Inputs	Short description	Unit
75	7.2.3.	Cooling airflow – Average value (emissions measurement section)	Calculate and report the average measured cooling airflow during the emissions measurement section. Use the 1Hz data of the parameter “Cooling Airflow Actual” in the Time-Based File to calculate the average over the WLTP-Brake cycle (soaking sections not included)	m <sup>3</sup> /h
76	7.2.3.	Cooling airflow – Difference with the nominal flow (emissions measurement section)	Calculate and report the per cent difference with the nominal cooling airflow during the emissions measurement section	%
77	7.2.3.	Cooling airflow – Average normalized value (emissions measurement section)	Calculate and report the average normalized measured cooling airflow during the emissions measurement section. Use the 1Hz data of the parameter “Cooling Airflow Actual Normalized” in the Time-Based File to calculate the average over the WLTP-Brake cycle (soaking sections not included)	Nm <sup>3</sup> /h
78	7.2.3.	Cooling airspeed – Average value (emissions measurement section)	Calculate and report in the Time-Based File the instantaneous cooling airspeed during the emissions measurement section following Equation 7.3. Calculate and report the average cooling airspeed during the emissions measurement section. Use the 1Hz data of the parameter “Cooling Airspeed Actual” in the Time-Based File to calculate the average over the WLTP-Brake cycle (soaking sections not included)	km/h
79	7.2.3.	Average cooling airflow – Overall compliance	Verify that all parts of the test comply with the requirements set out in this UN GTR regarding the difference between the nominal cooling airflow and the average measured cooling airflow	Y/N
80	7.2.3.	Instantaneous airflow violations – Cooling adjustment section	Calculate and report the number of the cooling airflow readings (1Hz) with a difference between 5 per cent and 10 per cent compared to the nominal value during the successful iteration of the cooling adjustment section. Use the 1Hz data of the parameter “Cooling Airflow Actual” in the Time-Based File to calculate the number of such occurrences over Trip #10	#
81	7.2.3.	Instantaneous airflow violations – Emissions measurement section	Calculate and report the number of the cooling airflow readings (1Hz) with a difference between 5 per cent and 10 per cent compared to the nominal value during the emissions measurement section. Use the 1Hz data of the parameter “Cooling Airflow Actual” in the Time-Based File to calculate the number of such occurrences over the WLTP-Brake cycle (soaking sections not included)	#
82	7.2.3.	Instantaneous cooling airflow – Overall compliance	Verify that the cooling adjustment and emissions measurement sections comply with the maximum allowed number of the instantaneous cooling airflow readings (1Hz) with a difference between 5 per cent and 10 per cent compared to the nominal value defined in this UN GTR	Y/N
83	7.2.3.	Instantaneous cooling airflow – Overall compliance	Verify that the instantaneous cooling airflow readings (1Hz) do not exceed a 10 per cent difference compared to the nominal cooling airflow value at any point of the cooling adjustment and emissions measurement sections	Y/N

No.	Paragraph	Parameters and Inputs	Short description	Unit
84	7.2.3.	System leak check – Average measured airflow	Calculate and report the average measured airflow during the leak check	m <sup>3</sup> /h
85	7.2.3.	System leak check – Overall compliance	Verify that the average measured airflow during the leak check meets the requirements set out in this UN GTR	Y/N
86	7.3.	Brake dynamometer and automation system – Overall compliance	Verify that the mandatory specifications for the brake dynamometer set out in paragraph 7.3. (a)-(e) are met	Y/N
87	7.3.	Brake dynamometer and automation system – Overall compliance	Verify that the mandatory specifications for the automation, control, and data acquisition system set out in paragraph 7.3. (f)-(h) are met	Y/N
88	7.4.2.	Brake enclosure design – Reynolds number at the entrance of the enclosure	Calculate and report the Reynolds number of the airflow at the entrance of the enclosure for the brake under testing. Calculate the Reynolds number only during the emissions measurement section following Equation 7.4. Use the 1Hz data of the parameter “Cooling Airspeed Actual” in the Time-Based File to calculate the average cooling airspeed over the WLTP-Brake cycle (soaking sections not included)	-
89	7.4.2.	Brake enclosure design – Speed uniformity verification at the minimum operational airflow	Verify that the airspeed at each position of the plane C used for the speed uniformity verification does not vary by more than ±35 per cent of the arithmetic mean of all measurements for the setup’s minimum operational airflow	Y/N
90	7.4.2.	Brake enclosure design – Speed uniformity verification at the maximum operational airflow	Verify that the airspeed at each position of the plane C used for the speed uniformity verification does not vary by more than ±35 per cent of the arithmetic mean of all measurements for the setup’s maximum operational airflow	Y/N
91	7.4.2.	Brake enclosure design – Overall compliance	Verify the compliance of the brake enclosure with all the specifications defined in paragraph 7.4.2. (a)-(l)	Y/N
92	7.4.3.	Brake enclosure dimensions – Length	Report the length of plane A1 ( $l_{A1}$ – enclosure’s length) as defined in paragraph 7.4.3.	mm
93	7.4.3.	Brake enclosure dimensions – Height	Report the length of plane D ( $h_D$ – enclosure’s height) as defined in paragraph 7.4.3.	mm
94	7.4.3.	Brake enclosure dimensions – Depth	Report the maximum axial depth of the enclosure at plane D as defined in paragraph 7.4.3.	mm
95	7.4.3.	Brake enclosure dimensions – Inlet and outlet diameter	Report the inlet and outlet diameter ( $d_i$ ) of the enclosure	mm
96	7.4.3.	Brake enclosure dimensions – Inlet and outlet transition length	Report the inlet and outlet transition length ( $l_i$ )	mm
97	7.4.3.	Brake enclosure dimensions – Inlet and outlet transition height	Report the inlet and outlet transition height ( $h_B$ )	mm
98	7.4.3.	Brake enclosure dimensions – Inlet’s height to enclosure’s height ratio	Report the inlet’s height ( $h_B$ ) to the enclosure’s height ( $h_D$ ) ratio	%
99	7.4.3.	Brake enclosure dimensions – Overall compliance	Verify the compliance of the brake enclosure dimensions with all the specifications defined in paragraph 7.4.3. (a)-(g)	Y/N
100	7.5.	Design of the sampling tunnel – Duct inner diameter	Report the inner diameter ( $d_i$ ) of the duct in the sampling tunnel	mm

No.	Paragraph	Parameters and Inputs	Short description	Unit
101	7.5.	Design of the sampling tunnel – Presence of a bend	Report if a bend is applied in the sampling tunnel (downstream of the brake enclosure's outlet and upstream of the sampling plane)	Y/N
102	7.5.	Design of the sampling tunnel – Bend's specifications (angle)	When a bend is applied in the sampling tunnel, report the bend's angle. If there is no bend report "NA"	°
103	7.5.	Design of the sampling tunnel – Bend's specifications (bending radius)	When a bend is applied in the sampling tunnel, report the bending radius as defined in Figure 7.6. If there is no bend report "NA"	X·d <sub>i</sub>
104	7.5.	Design of the sampling tunnel – Overall compliance	Verify the compliance of the sampling tunnel with all the specifications defined in paragraph 7.5. (a)-(i)	Y/N
105	7.6.	Design of the sampling plane – Number of probes	Report the number of sampling probes used for the brake emissions test	#
106	7.6.	Design of the sampling plane – Distance between the probes	Report the minimum distance between the probes (a <sub>1</sub> ) as specified in Figure 7.7.	mm
107	7.6.	Design of the sampling plane – Distance between probes and walls	Report the minimum distance between the probes and the tunnel wall (a <sub>2</sub> ) as specified in Figure 7.7.	mm
108	7.6.	Design of the sampling plane – Overall compliance	Verify the compliance of the sampling plane with all distance and placement specifications defined in paragraph 7.6. (a)-(f)	Y/N
109	8.3.	Brake temperature measurement – Thermocouples overall compliance	Verify the compliance of the used thermocouples with all the requirements defined in paragraph 8.3. (a)-(f)	Y/N
110	8.3.	Brake temperature measurement – Friction material temperature measurement	Report whether brake pads or shoes temperature was also measured in addition to the brake disc or drum temperature	Y/N
111	8.4.1.	Brake assembly – Fixture type	Specify the type of support fixture used for mounting the brake assembly on the inertia dynamometer (L0-U or L0-P or Other)	-
112	8.4.1.	Brake assembly – Overall compliance	Verify that the installation position and the type of support fixture used for the brake assembly meet the requirements specified in paragraph 8.4.1.	Y/N
113	8.4.1.	Brake assembly – Brake rotation	Report the rotation direction of the brake disc or drum (CW or CCW) with respect to the direction of evacuation	-
114	8.4.1.	Brake assembly – Brake rotation	Verify that the tested brake disc or drum rotates in the direction of the evacuation	Y/N
115	8.4.2.	Calliper orientation – Overall compliance	Verify that the calliper orientation of the brake under testing meets the requirements specified in paragraph 8.4.2.	Y/N
116	9.2.1.	Initial temperature – Cooling adjustment section	Report the initial brake temperature of the successful cooling adjustment iteration. Use the corresponding value of the parameter "Brake Temperature" in the Time-Based File (i.e. use the entry for brake temperature at the beginning of Trip #10)	°C
117	9.2.2.	Initial temperature – Bedding section	Report the initial brake temperature during the bedding section. Report the initial brake temperature for all five WLTP-Brake cycles separately. Use the corresponding values of the parameter "Brake Temperature" in the Time-Based File (i.e. use the entries for brake temperature at the beginning of each one of the five WLTP-Brake cycles)	°C
118	9.2.3.	Initial temperature – Emissions measurement section	Report the initial brake temperature in all ten trips of the WLTP-Brake cycle during the emissions measurement section as defined in paragraph 9.2.3. Use the corresponding	°C



<i>No.</i>	<i>Paragraph</i>	<i>Parameters and Inputs</i>	<i>Short description</i>	<i>Unit</i>
			values of the parameter “Brake Temperature” in the Time-Based File (i.e. use the entries for brake temperature at the beginning of Trips #1 to #10 of the WLTP-Brake cycle)	
119	9.2.1., 9.2.2., 9.2.3.	Initial temperature – Overall compliance	Verify that the initial brake temperature in all testing sections complies with the criteria defined in paragraphs 9.2.1., 9.2.2., and 9.2.3.	Y/N
120	9.3.1., 9.3.2., 9.3.3.	WLTP-Brake cycle interruptions – Occurrence	Report whether any interruption occurred during any part of the brake emissions test	Y/N
121	9.3.1., 9.3.2., 9.3.3.	WLTP-Brake cycle interruptions – Overall compliance	When one or more interruptions occurred, verify that all necessary steps were taken to resume testing in accordance with the specifications defined in paragraphs 9.3.1., 9.3.2., and 9.3.3.	Y/N/NA
122	9.3.1., 9.3.2., 9.3.3.	WLTP-Brake cycle interruptions – Overall compliance	Verify that the brake under testing was not disassembled at any point of the overall brake emissions test	Y/N
123	9.4.1.	Speed violations – Cooling adjustment section	Calculate and report the percentage of speed violations during the successful iteration of the cooling adjustment section. Use the 1Hz data of the parameters “Linear Speed Actual” and “Linear Speed Nominal” in the Time-Based File. Compare the 1Hz data of the two parameters to calculate the number and the overall percentage of speed violations over Trip #10	%
124	9.4.1.	Speed violations – Bedding section	Calculate and report the percentage of speed violations during the bedding section. Perform the calculation for all five WLTP-Brake cycles separately. Use the 1Hz data of the parameters “Linear Speed Actual” and “Linear Speed Nominal” in the Time-Based File. Compare the 1Hz data of the two parameters to calculate the number and the overall percentage of speed violations over the 5 WLTP-Brake cycles	%
125	9.4.1.	Speed violations – Emissions measurement section	Calculate and report the percentage of speed violations during the emissions measurement section. Use the 1Hz data of the parameters “Linear Speed Actual” and “Linear Speed Nominal” in the Time-Based File. Compare the 1Hz data of the two parameters to calculate the number and the overall percentage of speed violations over the WLTP-Brake cycle	%
126	9.4.1.	Speed violations – Overall compliance	Verify that all sections of the brake emissions test comply with the speed violations criteria defined in paragraph 9.4.1. (a)-(g)	Y/N
127	9.4.2.	Number of deceleration events – Count using the “Stop duration”	Report the number of numerical and non-zero values of the parameter “Stop Duration” in the Event-Based File over the emissions measurement section	#
128	9.4.2.	Number of deceleration events – Count using the “Deceleration rate”	Report the number of numerical and non-zero values of the parameter “Deceleration Rate - Distance Averaged” in the Event-Based File over the emissions measurement section	#
129	9.4.2.	Number of deceleration events – Overall compliance	Verify that the number of brake events equals 303 as specified in paragraph 9.4.2.	Y/N

<i>No.</i>	<i>Paragraph</i>	<i>Parameters and Inputs</i>	<i>Short description</i>	<i>Unit</i>
130	9.4.3.	Kinetic energy dissipation – $W_f$ during the cooling adjustment section	Calculate and report the kinetic energy dissipation ( $W_f$ ) during the successful iteration of the cooling adjustment section following Equation 9.1. Use the data of the parameters “Stop Duration”, “Rotational Speed – Time Averaged”, and “Brake Torque – Time Averaged” in the Event-Based File. Sum the calculated specific friction work from the individual brake events to report the total specific friction work over Trip #10 of the cooling adjustment section	J/kg
131	9.4.3.	Kinetic energy dissipation – Deviation from the nominal value (cooling adjustment section)	Calculate and report the per cent difference from the nominal friction work value during the successful iteration of the cooling adjustment section	%
132	9.4.3.	Kinetic energy dissipation – $W_f$ during the bedding section	Calculate and report the kinetic energy dissipation ( $W_f$ ) during the bedding section following Equation 9.1. Report the kinetic energy dissipation for all five WLTP-Brake cycles separately. Use the data of the parameters “Stop Duration”, “Rotational Speed – Time Averaged”, and “Brake Torque – Time Averaged” in the Event-Based File. Sum the calculated specific friction work from the individual brake events to report the total specific friction work over each WLTP-Brake cycle of the bedding section	J/kg
133	9.4.3.	Kinetic energy dissipation – Deviation from the nominal value (bedding section)	Calculate and report the per cent difference from the nominal friction work value during the bedding section. Report the deviation from the nominal value for all five WLTP-Brake cycles of the bedding section	%
134	9.4.3.	Kinetic energy dissipation – $W_f$ during the emissions measurement section	Calculate and report the kinetic energy dissipation ( $W_f$ ) during the emissions measurement section following Equation 9.1. Use the data of the parameters “Stop Duration”, “Rotational Speed – Time Averaged”, and “Brake Torque – Time Averaged” in the Event-Based File. Sum the calculated specific friction work from the individual brake events to report the total specific friction work over the WLTP-Brake cycle of the emissions measurement section	J/kg
135	9.4.3.	Kinetic energy dissipation – Deviation from the nominal value (emissions measurement section)	Calculate and report the per cent difference from the nominal friction work value during the emissions measurement section	%
136	9.4.3.	Kinetic energy dissipation – Overall compliance	Verify that all sections of the brake emissions test comply with the kinetic energy dissipation criteria specified in paragraph 9.4.3. (a)-(j)	Y/N
137	10.1.1.	Nominal front wheel load/disc or drum mass ratio ( $WL_{n-f}/DM$ )	Calculate and report the nominal front wheel load to disc mass (or drum mass in the case of front drum brakes) ratio ( $WL_{n-f}/DM$ ) for the brake under testing. In the case of non-friction braking, use the parameters of the brake emissions family parent to calculate and report the nominal front wheel load to disc mass	-
138	10.1.3.	ABT over Trip #10 of the WLTP-Brake cycle – Measured value (cooling adjustment section)	Calculate and report the average brake temperature during the successful iteration of the cooling adjustment section for the brake under testing ( $B_1$ ). Use the 1Hz data of the parameter “Brake Temperature” in the	°C

No.	Paragraph	Parameters and Inputs	Short description	Unit
			Time-Based File to calculate the average brake temperature over Trip #10	
139	10.1.3.	ABT over Trip #10 of the WLTP-Brake cycle – Difference to the target value (cooling adjustment section)	Calculate and report the difference between the average brake temperature during the successful iteration of the cooling adjustment section to the target average brake temperature for the brake under testing (C <sub>1</sub> ) following Equation 10.3	°C
140	10.1.3.	Average IBT of selected brake events from Trip #10 of the WLTP-Brake cycle – Measured value (cooling adjustment section)	Calculate and report the average IBT of the selected brake events during the successful iteration of the cooling adjustment section of the brake under testing (B <sub>2</sub> ). Use the corresponding data of the parameter “Initial Brake Temperature” for the target events in the Event-Based File to calculate the average IBT according to 10.1.3. (b)	°C
141	10.1.3.	Average IBT of selected brake events from Trip #10 of the WLTP-Brake cycle – Difference to the target value (cooling adjustment section)	Calculate and report the difference between the average IBT of the selected brake events during the successful iteration of the cooling adjustment section to the target average IBT for the brake under testing (C <sub>2</sub> ) following Equation 10.4	°C
142	10.1.3.	Average FBT of selected brake events from Trip #10 of the WLTP-Brake cycle – Measured value (cooling adjustment section)	Calculate and report the average FBT of the selected brake events during the successful iteration of the cooling adjustment section of the brake under testing (B <sub>3</sub> ). Use the corresponding data of the parameter “Final Brake Temperature” for the target events in the Event-Based File to calculate the average FBT according to 10.1.3. (c)	°C
143	10.1.3.	Average FBT of selected brake events from Trip #10 of the WLTP-Brake cycle – Difference to the target value (cooling adjustment section)	Calculate and report the difference between the average FBT of the selected brake events during the successful iteration of the cooling adjustment section to the target average FBT for the brake under testing (C <sub>3</sub> ) following Equation 10.5	°C
144	10.1.2., 10.1.3.	Definition of the nominal (set) cooling airflow for the specific brake – Overall compliance	Verify that the temperatures of the target parameters measured during the cooling adjustment section for the brake under testing are compliant with the target values defined in Table 10.2.	Y/N
145	10.1.4.	Definition of the nominal (set) cooling airflow for the specific brake – number of iterations	Report the number of iterations (i.e. repetitions of Trip #10) applied during the cooling adjustment section for the given brake	#
146	11.1., 11.2.	Bedding section – Number of complete WLTP-Brake cycles	Report the number of complete WLTP-Brake cycles carried out during the bedding section	#
147	11.1., 11.2.	Bedding section – Overall compliance	Verify that the bedding section was carried out and completed fulfilling all the specifications described in paragraphs 11.1. (a)-(g) or 11.2. (a)-(g)	Y/N
148	11.1., 11.2.	Bedding section – Use of new parts in case of failure	In the case of a failed bedding procedure as specified in paragraphs 11.1. and 11.2., verify that new brake parts have been used to start over the bedding section	Y/N/NA
149	12.1.1.1.	PM sampling plane – Flow splitting	Verify that the PM <sub>2.5</sub> and PM <sub>10</sub> sampling units do not apply flow splitting anywhere between the PM sampling probe’s inlet to the filters	Y/N
150	12.1.1.1.	PM sampling plane – Overall compliance	Verify that the design of the sampling plane and the placement of the PM <sub>2.5</sub> and PM <sub>10</sub> sampling probes fulfil the specifications described in paragraph 12.1.1.1. (a)-(d)	Y/N

No.	Paragraph	Parameters and Inputs	Short description	Unit
151	12.1.1.2.	PM sampling probes – PM <sub>2.5</sub> probe dimensions (inner diameter)	Report the PM <sub>2.5</sub> sampling probe inner diameter ( $d_p$ ) used for the brake under testing	mm
152	12.1.1.2.	PM sampling probes – PM <sub>10</sub> probe dimensions (inner diameter)	Report the PM <sub>10</sub> sampling probe inner diameter ( $d_p$ ) used for the brake under testing	mm
153	12.1.1.2.	PM sampling probes – PM <sub>2.5</sub> probe dimensions (length)	Report the PM <sub>2.5</sub> sampling probe's overall length from the sampling nozzle tip to the inlet of the PM separation device	mm
154	12.1.1.2.	PM sampling probes – PM <sub>10</sub> probe dimensions (length)	Report the PM <sub>10</sub> sampling probe's overall length from the sampling nozzle tip to the inlet of the PM separation device	mm
155	12.1.1.2.	PM sampling probes – Application of a bend	Report if a bend is applied to the PM <sub>2.5</sub> and/or PM <sub>10</sub> sampling probes used for the brake under testing	Y/N
156	12.1.1.2.	PM sampling probes – PM <sub>2.5</sub> probe application of a bend (bending radius)	When a bend is applied to the PM <sub>2.5</sub> sampling probe report its bending radius in probe diameters. If there is no bend report "NA"	$X \cdot d_p$
157	12.1.1.2.	PM sampling probes – PM <sub>10</sub> probe application of a bend (bending radius)	When a bend is applied to the PM <sub>10</sub> sampling probe report its bending radius in probe diameters. If there is no bend report "NA"	$X \cdot d_p$
158	12.1.1.2.	PM sampling probes – Overall compliance	Verify that the PM <sub>2.5</sub> and PM <sub>10</sub> sampling probes used for the brake under testing meet all the requirements specified in paragraph 12.1.1.2. (a)-(f)	Y/N
159	12.1.1.3.	PM sampling nozzles – PM <sub>2.5</sub> nozzle dimensions (inner diameter)	Report the PM <sub>2.5</sub> sampling nozzle inner diameter ( $d_n$ ) used for the brake under testing	mm
160	12.1.1.3.	PM sampling nozzles – PM <sub>10</sub> nozzle dimensions (inner diameter)	Report the PM <sub>10</sub> sampling nozzle inner diameter ( $d_n$ ) used for the brake under testing	mm
161	12.1.1.3.	PM sampling nozzles – PM <sub>2.5</sub> nozzle aspiration angle	Report the PM <sub>2.5</sub> sampling nozzle aspiration angle applied for the brake under testing	°
162	12.1.1.3.	PM sampling nozzles – PM <sub>10</sub> nozzle aspiration angle	Report the PM <sub>10</sub> sampling nozzle aspiration angle applied for the brake under testing	°
163	12.1.1.3.	PM sampling nozzles – Overall compliance	Verify that the PM <sub>2.5</sub> and PM <sub>10</sub> sampling nozzles used for the brake under testing meet all the requirements specified in paragraph 12.1.1.3. (a)-(h)	Y/N
164	12.1.2.1.	PM separation device – PM <sub>2.5</sub> cyclone cut-off size	Report the PM <sub>2.5</sub> cyclonic separator cut-off size used for the brake under testing	µm
165	12.1.2.1.	PM separation device – PM <sub>10</sub> cyclone cut-off size	Report the PM <sub>10</sub> cyclonic separator cut-off size used for the brake under testing	µm
166	12.1.2.1.	PM separation device – Overall compliance	Verify that the PM <sub>2.5</sub> and PM <sub>10</sub> cyclonic separators used for the brake under testing meet all the requirements specified in paragraph 12.1.2.1. (a)-(c)	Y/N
167	12.1.2.2.	PM sampling line – PM <sub>2.5</sub> line dimensions (inner diameter)	Report the PM <sub>2.5</sub> sampling line inner diameter ( $d_s$ ) used for the brake under testing	mm
168	12.1.2.2.	PM sampling line – PM <sub>10</sub> line dimensions (inner diameter)	Report the PM <sub>10</sub> sampling line inner diameter ( $d_s$ ) used for the brake under testing	mm
169	12.1.2.2.	PM sampling line – PM <sub>2.5</sub> line dimensions (length)	Report the PM <sub>2.5</sub> sampling line overall length from the cyclone to the tip of the filter holder used for the brake under testing	mm
170	12.1.2.2.	PM sampling line – PM <sub>10</sub> line dimensions (length)	Report the PM <sub>10</sub> sampling line overall length from the cyclone to the tip of the filter holder used for the brake under testing	mm
171	12.1.2.2.	PM sampling line – Application of a bend	Report if a bend is applied to the PM <sub>2.5</sub> and/or PM <sub>10</sub> sampling lines used for the brake under testing	Y/N

No.	Paragraph	Parameters and Inputs	Short description	Unit
172	12.1.2.2.	PM sampling line – PM <sub>2.5</sub> line bending radius	When a bend is applied to the PM <sub>2.5</sub> sampling line report its bending radius in sampling line diameters. If there is no bend report “NA”	X·ds
173	12.1.2.2.	PM sampling line – PM <sub>10</sub> line bending radius	When a bend is applied to the PM <sub>10</sub> sampling line report its bending radius in sampling line diameters. If there is no bend report “NA”	X·ds
174	12.1.2.2.	PM sampling line – Overall compliance	Verify that the PM <sub>2.5</sub> and PM <sub>10</sub> sampling lines used for the brake under testing meet all the requirements specified in paragraph 12.1.2.2. (a)-(f)	Y/N
175	12.1.2.3.	PM sampling flow – PM <sub>2.5</sub> nominal flow	Report the set (nominal) flow value for PM <sub>2.5</sub> sampling for the brake under testing ( $Q_{PM2.5-set}$ )	l/min
176	12.1.2.3.	PM sampling flow – PM <sub>10</sub> nominal flow	Report the set (nominal) flow value for PM <sub>10</sub> sampling for the brake under testing ( $Q_{PM10-set}$ )	l/min
177	12.1.2.3.	PM sampling flow – PM <sub>2.5</sub> measured flow	Calculate and report the average measured PM <sub>2.5</sub> sampling flow over the emissions measurement section for the brake under testing. Use the 1Hz data of the parameter “PM <sub>2.5</sub> Sampling Flow Actual” in the Time-Based File to calculate the average measured flow over the WLTP-Brake cycle (cooling sections not included)	l/min
178	12.1.2.3.	PM sampling flow – PM <sub>10</sub> measured flow	Calculate and report the average measured PM <sub>10</sub> sampling flow over the emissions measurement section for the brake under testing. Use the 1Hz data of the parameter “PM <sub>10</sub> Sampling Flow Actual” in the Time-Based File to calculate the average measured flow over the WLTP-Brake cycle (cooling sections not included)	l/min
179	12.1.2.3.	PM sampling flow – PM <sub>2.5</sub> normalized measured flow	Report the average normalized measured PM <sub>2.5</sub> sampling flow over the emissions measurement section for the brake under testing ( $NQ_{PM2.5}$ ). Use the 1Hz data of the parameter “PM <sub>2.5</sub> Sampling Flow Actual Normalized” in the Time-Based File to calculate the average measured flow over the WLTP-Brake cycle (cooling sections not included)	Nl/min
180	12.1.2.3.	PM sampling flow – PM <sub>10</sub> normalized measured flow	Report the average normalized measured PM <sub>10</sub> sampling flow over the emissions measurement section for the brake under testing ( $NQ_{PM10}$ ). Use the 1Hz data of the parameter “PM <sub>10</sub> Sampling Flow Actual Normalized” in the Time-Based File to calculate the average measured flow over the WLTP-Brake cycle (cooling sections not included)	Nl/min
181	12.1.2.3., 12.1.2.4.	PM sampling flow – PM <sub>2.5</sub> isokinetic ratio	Calculate and report the average isokinetic ratio for PM <sub>2.5</sub> sampling over the emissions measurement section for the brake under testing. Apply Equation 12.4 and use the PM <sub>2.5</sub> nozzle diameter and the 1Hz data of the parameters “Cooling Airflow Actual Normalized” and “PM <sub>2.5</sub> Sampling Flow Actual Normalized” in the Time-Based File to calculate the average isokinetic ratio over the WLTP-Brake cycle (cooling sections not included)	-
182	12.1.2.3., 12.1.2.4.	PM sampling flow – PM <sub>10</sub> isokinetic ratio	Calculate and report the average isokinetic ratio for PM <sub>10</sub> sampling over the emissions measurement section for the brake under	-

No.	Paragraph	Parameters and Inputs	Short description	Unit
			testing. Apply Equation 12.4 and use the PM <sub>10</sub> nozzle diameter and the IHz data of the parameters “Cooling Airflow Actual Normalized” and “PM <sub>10</sub> Sampling Flow Actual Normalized” in the Time-Based File to calculate the average isokinetic ratio over the WLTP-Brake cycle (cooling sections not included)	
183	12.1.2.3.	PM sampling flow – Overall compliance	Verify that all the specifications for the PM <sub>2.5</sub> and PM <sub>10</sub> sampling flow as well as for the PM <sub>2.5</sub> and PM <sub>10</sub> isokinetic ratio defined in paragraph 12.1.2.3. (a)-(i) for the brake under testing are fulfilled	Y/N
184	12.1.3.1.	PM filter holder – PM <sub>2.5</sub> filter holder overall compliance	Verify that the PM <sub>2.5</sub> filter holder meets all the requirements defined in paragraph 12.1.3.1. (a)-(d)	Y/N
185	12.1.3.1.	PM filter holder – PM <sub>10</sub> filter holder overall compliance	Verify that the PM <sub>10</sub> filter holder meets all the requirements defined in paragraph 12.1.3.1. (a)-(d)	Y/N
186	12.1.3.2.	PM sampling filters – Type of filter for PM <sub>2.5</sub> sampling	Specify the type of filter (filter material) used for PM <sub>2.5</sub> sampling for the brake under testing	-
187	12.1.3.2.	PM sampling filters – Type of filter for PM <sub>10</sub> sampling	Specify the type of filter (filter material) used for PM <sub>10</sub> sampling for the brake under testing	-
188	12.1.3.2.	PM sampling filters – Overall compliance	Verify that the filters used for PM <sub>2.5</sub> and PM <sub>10</sub> sampling for the brake under testing meets all the requirements defined in paragraph 12.1.3.2.	Y/N
189	12.1.4.	Weighing procedure – Climatic room	Verify that the weighing balance has been stored in an appropriate room fulfilling all the requirements described in paragraph 12.1.4.	Y/N
190	12.1.4.	Weighing procedure – Balance resolution	Report the resolution of the weighing balance used for weighing the PM <sub>10</sub> and PM <sub>2.5</sub> filters	µg
191	12.1.4.	Weighing procedure – Pre-sampling date and time	Report the pre-sampling weighing date and time of the PM <sub>2.5</sub> and PM <sub>10</sub> filters used for the brake under testing	-
192	12.1.4.	Weighing procedure – Pre-sampling room’s temperature	Report the pre-sampling weighing room’s average temperature during the measurement of the PM <sub>10</sub> and PM <sub>2.5</sub> filter weights	°C
193	12.1.4.	Weighing procedure – Pre-sampling room’s RH	Report the pre-sampling weighing room’s average relative humidity during the measurement of the PM <sub>10</sub> and PM <sub>2.5</sub> filter weights	%
194	12.1.4.	Weighing procedure – Pre-sampling PM <sub>2.5</sub> filter weight	Report the final pre-sampling PM <sub>2.5</sub> filter weight for the brake under testing. Calculate the pre-sampling PM <sub>2.5</sub> filter weight in accordance with the procedure defined in point (g) of paragraph 12.1.4. ( $Pe_{(Uncorrected)}$ )	µg
195	12.1.4.	Weighing procedure – Pre-sampling PM <sub>2.5</sub> filter weight corrected	Report the corrected for buoyancy pre-sampling PM <sub>2.5</sub> filter weight for the brake under testing ( $Pe_{(Corrected)}$ ). Use Equation 12.5 to calculate the corrected mass measurement	µg
196	12.1.4.	Weighing procedure – Pre-sampling PM <sub>10</sub> filter weight	Report the final pre-sampling PM <sub>10</sub> filter weight for the brake under testing. Calculate the pre-sampling PM <sub>10</sub> filter weight in accordance with the procedure defined in point (g) of paragraph 12.1.4. ( $Pe_{(Uncorrected)}$ )	µg
197	12.1.4.	Weighing procedure – Pre-sampling PM <sub>10</sub> filter weight corrected	Report the corrected for buoyancy pre-sampling PM <sub>10</sub> filter weight for the brake under testing ( $Pe_{(Corrected)}$ ). Use Equation	µg

No.	Paragraph	Parameters and Inputs	Short description	Unit
			12.5 to calculate the corrected mass measurement	
198	12.1.4.	Weighing procedure – Post-sampling date and time	Report the post-sampling weighing date and time of the PM <sub>2.5</sub> and PM <sub>10</sub> filters used for the brake under testing	-
199	12.1.4.	Weighing procedure – Post-sampling room's temperature	Report the post-sampling weighing room's average temperature during the measurement of the PM <sub>10</sub> and PM <sub>2.5</sub> filter weights	°C
200	12.1.4.	Weighing procedure – Post-sampling room's RH	Report the post-sampling weighing room's average relative humidity during the measurement of the PM <sub>10</sub> and PM <sub>2.5</sub> filter weights	%
201	12.1.4.	Weighing procedure – Post-sampling PM <sub>2.5</sub> filter weight	Report the final post-sampling PM <sub>2.5</sub> filter weight for the brake under testing. Calculate the post-sampling PM <sub>2.5</sub> filter weight in accordance with the procedure defined in point (g) of paragraph 12.1.4. ( $P_{e(Uncorrected)}$ )	µg
202	12.1.4.	Weighing procedure – Post-sampling PM <sub>2.5</sub> filter weight corrected	Report the corrected for buoyancy post-sampling PM <sub>2.5</sub> filter weight for the brake under testing ( $P_{e(Corrected)}$ ). Use Equation 12.5 to calculate the corrected mass measurement	µg
203	12.1.4.	Weighing procedure – Post-sampling PM <sub>10</sub> filter weight	Report the final post-sampling PM <sub>10</sub> filter weight for the brake under testing. Calculate the post-sampling PM <sub>10</sub> filter weight in accordance with the procedure defined in point (g) of paragraph 12.1.4. ( $P_{e(Uncorrected)}$ )	µg
204	12.1.4.	Weighing procedure – Post-sampling PM <sub>10</sub> filter weight corrected	Report the corrected for buoyancy post-sampling PM <sub>10</sub> filter weight for the brake under testing ( $P_{e(Corrected)}$ ). Use Equation 12.5 to calculate the corrected mass measurement	µg
205	12.1.4.	Weighing procedure – PM <sub>2.5</sub> final filter load	Report the PM <sub>2.5</sub> filter mass loading for the brake under testing ( $P_{e(2.5)}$ ). Use the corrected for buoyancy pre-testing and post-testing PM <sub>2.5</sub> filter measurements for the calculation as specified in point 12.1.4. (g)	µg
206	12.1.4.	Weighing procedure – PM <sub>10</sub> final filter load	Report the PM <sub>10</sub> filter mass loading for the brake under testing ( $P_{e(10)}$ ). Use the corrected for buoyancy pre-testing and post-testing PM <sub>10</sub> filter measurements for the calculation as specified in point 12.1.4. (g)	µg
207	12.1.4.	Weighing procedure – Overall compliance	Verify that all requirements defined in paragraph 12.1.4. for conditioning, handling, and weighing of the PM <sub>2.5</sub> and PM <sub>10</sub> filters used for the brake under testing have been fulfilled	Y/N
208	12.1.4.	Weighing procedure – PM <sub>2.5</sub> reference filter initial weight	Report the initial corrected for buoyancy PM <sub>2.5</sub> reference filter weight for the brake under testing. Use Equation 12.5 to calculate the corrected mass measurement	µg
209	12.1.4.	Weighing procedure – PM <sub>2.5</sub> reference filter final weight	Report the final corrected for buoyancy PM <sub>2.5</sub> reference filter weight for the brake under testing. Use Equation 12.5 to calculate the corrected mass measurement	µg
210	12.1.4.	Weighing procedure – PM <sub>10</sub> reference filter initial weight	Report the initial corrected for buoyancy PM <sub>10</sub> reference filter weight for the brake under testing. Use Equation 12.5 to calculate the corrected mass measurement	µg
211	12.1.4.	Weighing procedure – PM <sub>10</sub> reference filter final weight	Report the final corrected for buoyancy PM <sub>10</sub> reference filter weight for the brake under testing. Use Equation 12.5 to calculate the corrected mass measurement	µg

No.	Paragraph	Parameters and Inputs	Short description	Unit
212	12.1.4.	Weighing procedure – Verification of reference filters validity	Verify that the average difference between the initial and final measurement for the PM <sub>2.5</sub> and PM <sub>10</sub> reference filters is within $\pm 10 \mu\text{g}$ in accordance with the specifications defined in paragraph 12.1.4. (f)	Y/N
213	12.1.4.	Weighing procedure – Overall compliance of reference filters weighing procedure	Verify that the weighing of PM <sub>2.5</sub> and PM <sub>10</sub> reference filters was carried out according to the specifications defined in paragraph 12.1.4. (f)	Y/N
214	12.1.5.	PM emission factor calculation – Reference PM <sub>2.5</sub> Emission Factor	Report the PM <sub>2.5</sub> emission factor in mass per distance driven for the brake under testing as specified in paragraph 12.1.5. (PM <sub>2.5</sub> EF <sub>ref</sub> ). Use the PM <sub>2.5</sub> filter mass loading for the brake under testing (Pe <sub>(2.5)</sub> ) calculated in the Mass Measurement File. Use the data of the parameters “Cooling Airflow Actual Normalized”, “PM <sub>2.5</sub> Sampling Flow Actual Normalized”, and “Driven Distance” in the Time-Based File over the WLTP-Brake cycle of the emissions measurement section	mg/km
215	12.1.5.	PM emission factor calculation – Final PM <sub>2.5</sub> Emission Factor	Report the final PM <sub>2.5</sub> emission factor in mass per distance driven for the vehicle on which the brake under testing is mounted (PM <sub>2.5</sub> EF). Perform the calculation in accordance with Equation 12.9 as specified in paragraph 12.1.5.	mg/km
216	12.1.5.	PM emission factor calculation – Reference PM <sub>10</sub> Emission Factor	Report the PM <sub>10</sub> emission factor in mass per distance driven for the brake under testing as specified in paragraph 12.1.5. (PM <sub>10</sub> EF <sub>ref</sub> ). Use the PM <sub>10</sub> filter mass loading for the brake under testing (Pe <sub>(10)</sub> ) calculated in the Mass Measurement File. Use the data of the parameters “Cooling Airflow Actual Normalized”, “PM <sub>10</sub> Sampling Flow Actual Normalized”, and “Driven Distance” in the Time-Based File over the WLTP-Brake cycle of the emissions measurement section	mg/km
217	12.1.5.	PM emission factor calculation – Final PM <sub>10</sub> Emission Factor	Report the final PM <sub>10</sub> emission factor in mass per distance driven for the vehicle on which the brake under testing is mounted (PM <sub>10</sub> EF). Perform the calculation in accordance with Equation 12.10 as specified in paragraph 12.1.5.	mg/km
218	12.2.1.1.	PN sampling plane – PN sampling layout	Specify if one or two sampling probes were used for TPN10 and SPN10 sampling for the brake under testing	-
219	12.2.1.1.	PN sampling plane – PN sampling probes positioning	Verify that the design of the sampling plane and the placement of the TPN10 and SPN10 sampling probes fulfil the specifications described in paragraph 12.2.1.1. (a)-(b)	Y/N
220	12.2.1.1.	PN sampling plane – Flow angle of the flow splitter	When a single sampling probe is used for both TPN10 and SPN10 report the flow angle of the applied flow splitter	°
221	12.2.1.1.	PN sampling plane – Overall compliance of the flow splitter	When a single sampling probe is used for both TPN10 and SPN10 verify that the applied flow-splitting device meets all the design, flow velocity, and penetration requirements defined in points 12.2.1.1. (c)-(e)	Y/N/NA
222	12.2.1.2.	PN sampling probes – TPN10 probe dimensions (inner diameter)	Report the TPN10 sampling probe’s inner diameter (d <sub>p</sub> ) used for the brake under testing	mm
223	12.2.1.2.	PN sampling probes – SPN10 probe dimensions (inner diameter)	Report the SPN10 sampling probe’s inner diameter (d <sub>p</sub> ) used for the brake under testing	mm



No.	Paragraph	Parameters and Inputs	Short description	Unit
224	12.2.1.2.	PN sampling probes – TPN10 probe dimensions (length)	Report the TPN10 sampling probe's overall length from the sampling nozzle tip to the inlet of the particle transfer tube used for the brake under testing	mm
225	12.2.1.2.	PN sampling probes – SPN10 probe dimensions (length)	Report the SPN10 sampling probe's overall length from the sampling nozzle tip to the inlet of the particle transfer tube used for the brake under testing	mm
226	12.2.1.2.	PN sampling probes – Application of a bend	Report if a bend is applied to TPN10 and SPN10 sampling probe(s) used for the brake under testing	Y/N
227	12.2.1.2.	PN sampling probes – TPN10 bending radius	When a bend is applied to the TPN10 sampling probe report its bending radius in probe diameters. If there is no bend report "NA"	X·d <sub>p</sub>
228	12.2.1.2.	PN sampling probes – SPN10 bending radius	When a bend is applied to the SPN10 sampling probe report its bending radius in probe diameters. If there is no bend report "NA"	X·d <sub>p</sub>
229	12.2.1.2.	PN sampling probes – Overall compliance	Verify that the TPN10 and SPN10 sampling probe(s) used for the brake under testing meet all the requirements specified in paragraph 12.2.1.2. (a)-(f)	Y/N
230	12.2.1.3.	PN sampling nozzles – TPN10 nozzle dimensions (inner diameter)	Report the TPN10 sampling nozzle inner diameter (d <sub>n</sub> ) used for the brake under testing	mm
231	12.2.1.3.	PN sampling nozzles – SPN10 nozzle dimensions (inner diameter)	Report the SPN10 sampling nozzle inner diameter (d <sub>n</sub> ) used for the brake under testing	mm
232	12.2.1.3.	PN sampling nozzles – TPN10 aspiration angle	Report the TPN10 sampling nozzle aspiration angle applied for the brake under testing	°
233	12.2.1.3.	PN sampling nozzles – SPN10 aspiration angle	Report the SPN10 sampling nozzle aspiration angle applied for the brake under testing	°
234	12.2.1.3.	PN sampling nozzles – Overall compliance	Verify that the TPN10 and SPN10 sampling nozzles used for the brake under testing meet all the requirements specified in paragraph 12.2.1.3. (a)-(g)	Y/N
235	12.2.1.4.	PN transfer tube – TPN10 PTT dimensions (inner diameter)	Report the TPN10 particle transfer tube inner diameter (d <sub>tt</sub> ) used for the brake under testing	mm
236	12.2.1.4.	PN transfer tube – SPN10 PTT dimensions (inner diameter)	Report the SPN10 particle transfer tube inner diameter (d <sub>tt</sub> ) used for the brake under testing	mm
237	12.2.1.4.	PN transfer tube – Application of a bend	Report if a bend is applied to the TPN10 and/or SPN10 particle transfer tubes used for the brake under testing	Y/N
238	12.2.1.4.	PN transfer tube – TPN10 bending radius	When a bend is applied to the TPN10 particle transfer tube report its bending radius in sampling transfer tube diameters	X·d <sub>tt</sub>
239	12.2.1.4.	PN transfer tube – SPN10 bending radius	When a bend is applied to the SPN10 particle transfer tube report its bending radius in sampling transfer tube diameters	X·d <sub>tt</sub>
240	12.2.1.4.	PN transfer tube – Overall compliance	Verify that the TPN10 and SPN10 particle transfer tubes used for the brake under testing meet all the requirements specified in paragraph 12.2.1.4. (a)-(g)	Y/N
241	12.2.2.1.	PN separation device – TPN10 cut-off size	Report the TPN10 cyclonic separator cut-off size used for the brake under testing	µm
242	12.2.2.1.	PN separation device – SPN10 cut-off size	Report the SPN10 cyclonic separator cut-off size used for the brake under testing	µm
243	12.2.2.1.	PN separation device – Overall compliance	Verify that the PN cyclonic separator(s) used for the brake under testing meets all the requirements specified in paragraph 12.2.2.1. (a)-(e)	Y/N

No.	Paragraph	Parameters and Inputs	Short description	Unit
244	12.2.2.2.	PN sample conditioning – TPN10 average PCRF	Report the arithmetic average PCRF applied for the TPN10 sampling and measurement for the brake under testing. Use the 1Hz data of the parameter “TPN10 - Average PCRF” in the Time-Based File to calculate the arithmetic average PCRF over the WLTP-Brake cycle of the emissions measurement section	-
245	12.2.2.2.	PN sample conditioning – SPN10 average PCRF	Report the arithmetic average PCRF applied for the SPN10 sampling and measurement for the brake under testing. Use the 1Hz data of the parameter “SPN10 - Average PCRF” in the Time-Based File to calculate the arithmetic average PCRF over the WLTP-Brake cycle of the emissions measurement section	-
246	12.2.2.2.	PN sample conditioning – TPN10 overall compliance	Verify that the dilution system applied for the TPN10 sampling and measurement for the brake under testing meets all the requirements defined in paragraph 12.2.2.2. (a)-(j)	Y/N
247	12.2.2.2.	PN sample conditioning – SPN10 overall compliance	Verify that the volatile particle removal system applied for the SPN10 sampling and measurement for the brake under testing meets all the requirements defined in paragraph 12.2.2.2. (k)-(v)	Y/N
248	12.2.2.3.	PN internal transfer line – TPN10 line dimensions (inner diameter)	Report the TPN10 internal transfer line inner diameter ( $d_{ti}$ ) used for the brake under testing	mm
249	12.2.2.3.	PN internal transfer line – SPN10 line dimensions (inner diameter)	Report the SPN10 internal transfer line inner diameter ( $d_{ti}$ ) used for the brake under testing	mm
250	12.2.2.3.	PN internal transfer line – TPN10 line dimensions (length)	Report the TPN10 internal transfer line length from the exit of the dilution system to the inlet of the PNC for the brake under testing	mm
251	12.2.2.3.	PN internal transfer line – SPN10 line dimensions (length)	Report the SPN10 internal transfer line length from the exit of the VPR to the inlet of the PNC for the brake under testing	mm
252	12.2.2.3.	PN internal transfer line – Application of a bend	Report if a bend is applied to the TPN10 and/or SPN10 internal transfer line used for the brake under testing. If there is no bend report “NA”	Y/N
253	12.2.2.3.	PN internal transfer line – TPN10 bending radius	When a bend is applied to the TPN10 internal transfer line report its bending radius in transfer line diameters. If there is no bend report “NA”	X· $d_{ti}$
254	12.2.2.3.	PN internal transfer line – SPN10 bending radius	When a bend is applied to the SPN10 internal transfer line report its bending radius in transfer line diameters. If there is no bend report “NA”	X· $d_{ti}$
255	12.2.2.3.	PN internal transfer line – Overall compliance	Verify that the TPN10 and SPN10 internal transfer lines used for the brake under testing meet all the design requirements specified in paragraph 12.2.2.3.	Y/N
256	12.2.3.1.	Particle number counter – TPN10 PNC overall compliance	Verify that the particle number counter used for the measurement of TPN10 for the brake under testing meets all the requirements specified in paragraph 12.2.3.1. (a)-(i)	Y/N
257	12.2.3.1.	Particle number counter – SPN10 PNC overall compliance	Verify that the particle number counter used for the measurement of SPN10 for the brake under testing meets all the requirements specified in paragraph 12.2.3.1. (a)-(i)	Y/N
258	12.2.3.2.	PN sampling flow – TPN10 measured flow	Report the average normalized PN sampling flow value for TPN10 for the brake under testing. Use the 1Hz data of the parameter	l/min

No.	Paragraph	Parameters and Inputs	Short description	Unit
			“TPN10 Sampling Flow Actual Normalized” in the Time-Based File to calculate the average sampling flow over the WLTP-Brake cycle of the emissions measurement section	
259	12.2.3.2.	PN sampling flow – SPN10 measured flow	Report the average normalized PN sampling flow value for SPN10 for the brake under testing. Use the 1Hz data of the parameter “SPN10 Sampling Flow Actual Normalized” in the Time-Based File to calculate the average sampling flow over the WLTP-Brake cycle of the emissions measurement section	l/min
260	12.2.3.2.	PN sampling flow – TPN10 isokinetic ratio	Report the average isokinetic ratio for TPN10 sampling for the brake under testing. Use the TPN10 nozzle diameter and the 1Hz data of the parameters “Cooling Airflow Actual Normalized” and “TPN10 Sampling Flow Actual Normalized” in the Time-Based File (over the WLTP-Brake cycle of the emissions measurement section) for the calculation following Equation 12.4	-
261	12.2.3.2.	PN sampling flow – SPN10 isokinetic ratio	Report the average isokinetic ratio for SPN10 sampling for the brake under testing. Use the SPN10 nozzle diameter and the 1Hz data of the parameters “Cooling Airflow Actual Normalized” and “SPN10 Sampling Flow Actual Normalized” in the Time-Based File (over the WLTP-Brake cycle of the emissions measurement section) for the calculation following Equation 12.4	-
262	12.2.3.2.	PN sampling flow – Overall compliance	Verify that all the specifications for the TPN10 and SPN10 sampling flow as well as for the TPN10 and SPN10 isokinetic ratio defined in paragraph 12.2.3.2. (a)-(h) for the brake under testing are fulfilled	Y/N
263	12.2.4.	PN emission factor calculation – Reference TPN10 EF <sub>ref</sub>	Report the TPN10 emission factor (TPN10 EF <sub>ref</sub> ) in the number of particles per distance driven for the brake under testing as specified in paragraph 12.2.4.	#/km
264	12.2.4.	PN emission factor calculation – Final TPN10 EF	Report the final TPN10 emission factor in number of particles per distance driven for the vehicle on which the brake under testing is mounted. Perform the calculation in accordance with Equation 12.13 as specified in paragraph 12.2.4.	#/km
265	12.2.4.	PN emission factor calculation – TPN10 measurement range verification	Verify that the TPN10 emissions in #/Ncm <sup>3</sup> are within the specified measurement range of the PNC device. Use the 1Hz data of the parameter “TPN10 Concentration Normalized - PCRF Corrected” in the Time-Based File for performing the verification over the WLTP-Brake cycle of the emissions measurement section	Y/N
266	12.2.4.	PN emission factor calculation – Reference SPN10 EF <sub>ref</sub>	Report the SPN10 emission factor (SPN10 EF <sub>ref</sub> ) in the number of particles per distance driven for the brake under testing as specified in paragraph 12.2.4.	#/km
267	12.2.4.	PN emission factor calculation – Final SPN10 EF	Report the final SPN10 emission factor in number of particles per distance driven for the vehicle on which the brake under testing is mounted. Perform the calculation in accordance with Equation 12.14 as specified in paragraph 12.2.4.	#/km
268	12.2.4.	PN emission factor calculation – SPN10	Verify that the SPN10 emissions in #/Ncm <sup>3</sup> are within the specified measurement range	Y/N

<i>No.</i>	<i>Paragraph</i>	<i>Parameters and Inputs</i>	<i>Short description</i>	<i>Unit</i>
		measurement range verification	of the PNC device. Use the 1Hz data of the parameter “SPN10 Concentration Normalized - PCRF Corrected” in the Time-Based File for performing the verification over the WLTP-Brake cycle of the emissions measurement section	
269	12.2.5.	PN system verification procedures – Overall compliance	Verify that the PN system verification procedures defined in paragraph 12.2.5. (a)-(d) have been applied successfully for the brake under testing	Y/N
270	12.3.	Mass loss measurement – Disc or drum pre-test mass	Report the pre-test mass of the disc or drum with the thermocouple installed and the thermocouple connector removed	mg
271	12.3.	Mass loss measurement – Friction material pre-test mass	Report the total pre-test mass of the brake friction material including the anti-noise shims, pad-shim springs, and other elements when part of the product assembly. Use the data from the Mass Measurement File to report the sum of the pre-test masses for the brake friction material	mg
272	12.3.	Mass loss measurement – Disc or drum post-test mass	Report the post-test mass of the disc or drum with the thermocouple installed and the thermocouple connector removed	mg
273	12.3.	Mass loss measurement – Friction material post-test mass	Report the total post-test mass of the brake friction material including the anti-noise shims, pad-shim springs, and other elements when part of the product assembly. Use the data from the Mass Measurement File to report the sum of the post-test masses for the brake friction material	mg
274	12.3.	Mass loss measurement – Total mass loss	Report the total mass loss of the brake under testing following the procedure defined in Table 13.5. and paragraph 12.3. (j)	mg
275	12.3.	Mass loss measurement – Total distance driven	Calculate and report the total distance driven during the entire brake emissions test including all iterations of the cooling air adjustment, all bedding WLTP-Brake cycles, and the emissions measurement section (soaking sections not included)	km
276	12.3.	Mass loss measurement – Weight loss emission factor	Report the averaged weight loss emission factor of the brake under testing following the procedure defined in Table 13.5. and paragraph 12.3. (k)	mg/km
277	12.3.	Mass loss measurement – Overall compliance	Verify that the mass loss measurement of the brake under testing has been conducted following all the specifications described in paragraph 12.3. (a)-(k)	Y/N
278	14.2.	Calibration requirements – Inertia dynamometer	Verify that the calibration requirements defined for the brake dynamometer in Table 14.1. and paragraph 14.2. are met and that a valid calibration certificate is available at the time of the brake emissions test	Y/N
279	14.3.	Calibration requirements – Airflow measurement device	Verify that the calibration requirements defined for the cooling airflow measurement device in Table 14.1. and paragraph 14.3. are met and that a valid calibration certificate is available at the time of the brake emissions test	Y/N
280	14.1.	Calibration requirements – Cyclonic separators	Verify that the calibration requirements defined for the PM and PN cyclonic separators in Table 14.1. and paragraphs 12.1. and 12.2. are met and that valid calibration certificates are available at the time of the brake emissions test	Y/N
281	14.4.	Calibration requirements – Weighing balance	Verify that the calibration requirements defined for the microgram balance in Table	Y/N

<i>No.</i>	<i>Paragraph</i>	<i>Parameters and Inputs</i>	<i>Short description</i>	<i>Unit</i>
			14.1. and paragraph 14.4. are met and that a valid calibration certificate is available at the time of the brake emissions test	
282	14.1.	Calibration requirements – PM sampling flow measurement device	Verify that the calibration requirements defined for the PM sampling flow measurement device in Table 14.1. and paragraph 12.1. are met and that a valid calibration certificate is available at the time of the brake emissions test	Y/N
283	14.1.	Calibration requirements – PN sampling flow measurement device	Verify that the calibration requirements defined for the PN sampling flow measurement device in Table 14.1. and paragraph 12.2. are met and that a valid calibration certificate is available at the time of the brake emissions test	Y/N
284	14.5.	Calibration requirements – Sample treatment and conditioning devices	Verify that the calibration requirements defined for the TPN10 dilution system and the SPN10 volatile particle remover in Table 14.1. and paragraph 14.5. are met and that valid calibration certificates are available at the time of the brake emissions test	Y/N
285	14.6.	Calibration requirements – Particle number counter	Verify that the calibration requirements defined for the particle number counter in Table 14.1. and paragraph 14.6. are met and that a valid calibration certificate is available at the time of the brake emissions test	Y/N
286	14.4.	Calibration requirements – Brake parts balance	Verify that the calibration requirements defined for the brake parts balance in Table 14.1. and paragraph 14.4. are met and that a valid calibration certificate is available at the time of the brake emissions test	Y/N

## 14. Calibration Requirements and Ongoing Quality Controls

### 14.1. General Calibration Requirements

This paragraph summarises the minimum calibration requirements for the equipment used for brake emissions testing. Table 14.1. summarises the calibration criteria and the intervals for the main equipment defined in this UN GTR.

Table 14.1.

**Calibration requirements for main equipment for emissions measurements**

<i>Instrument</i>	<i>Interval</i>	<i>Criterion</i>	<i>Paragraph</i>
Brake dynamometer	Upon initial installation, yearly, and at major setup maintenance	Table 14.3.	Paragraph 14.2.
Torque measurement device	Upon initial installation, yearly, and at major setup maintenance	Table 14.4.	Paragraph 14.2.
Cooling airflow measurement device	Upon initial installation, yearly, and at major setup maintenance	Table 14.5.	Paragraph 14.3.
Cooling airflow temperature sensor	Yearly	$\pm 1^{\circ}\text{C}$	Paragraph 14.3.
Cooling airflow atmospheric pressure sensor	Yearly	$\pm 0.4\text{ kPa}$	Paragraph 14.3.
Cooling air temperature sensor	Yearly	$\pm 1^{\circ}\text{C}$	Paragraph 7.2.1.
Cooling air relative humidity sensor	Yearly	$\pm 5$ per cent of nominal	Paragraph 7.2.1.

<i>Instrument</i>	<i>Interval</i>	<i>Criterion</i>	<i>Paragraph</i>
PM <sub>10</sub> Cyclonic separator	Certificate of compliance supplied by cyclone manufacturer upon initial installation	Table 12.1.	Paragraph 12.1.
PM <sub>2.5</sub> Cyclonic separator	Certificate of compliance supplied by cyclone manufacturer upon initial installation	Table 12.2.	Paragraph 12.1.
Microgram balance	Upon initial installation, yearly, and at major setup maintenance	Table 14.6.	Paragraph 14.4.
PM sampling flow measurement device	Upon initial installation, yearly, and at major setup maintenance	±2.5 per cent of reading or ±1.5 per cent of full scale (whichever is the least)	Paragraph 12.1.
PM sampling flow temperature sensor	Yearly	±1°C	Paragraph 12.1.
PM sampling flow pressure sensor	Yearly	±1 kPa	Paragraph 12.1.
PN Cyclonic separator	Certificate of compliance supplied by cyclone manufacturer upon initial installation	Penetration efficiency of ≥80 per cent for a particle electrical mobility diameter of 1.5 µm	Paragraph 12.2.
PN sampling flow measurement device	13 months	±5 per cent of reading under all operating conditions	Paragraph 12.2.
PN sampling flow temperature sensor	Yearly	±1°C	Paragraph 12.2.
PN sampling flow pressure sensor	Yearly	±1 kPa	Paragraph 12.2.
Dilution system for TPN10	6 months or 13 months depending on the setup	Per paragraph 14.5.1.	Paragraph 14.5.
Volatile Particle Remover for SPN10	6 months or 13 months depending on the setup	Per paragraph 14.5.2.	Paragraph 14.5.
Particle Number Counter	13 months and at major maintenance	Per paragraph 14.6.	Paragraph 14.6.
Brake parts balance	Upon initial installation, yearly, and at major setup maintenance	Table 14.6.	Paragraph 14.4.

Any other sensor or auxiliary equipment used to determine temperature, atmospheric pressure, and ambient humidity in the facilities room or the balance room shall fulfil the requirements prescribed in Table 14.2.

Table 14.2.

#### Calibration requirements for auxiliary equipment

<i>Instrument</i>	<i>Interval</i>	<i>Criterion</i>
Temperature sensor	Yearly	±1°C
Atmospheric pressure sensor	Yearly	±1 kPa
Relative humidity sensor	Yearly	±5 per cent of nominal
Absolute humidity sensor	Yearly	±10 per cent of reading or 1 gH <sub>2</sub> O/kg dry air (whichever is greater)

#### 14.2. Brake Dynamometer

Table 14.3. summarises the calibration criteria and the intervals for the brake dynamometer defined in this UN GTR. The rotational speed, brake torque, and

brake pressure measurement devices shall comply with the linearity requirements of Table 14.4.

Table 14.3.

**Calibration requirements for the brake dynamometer**

<i>Instrument</i>	<i>Interval</i>	<i>Criterion</i>
Rotational speed device	Upon initial installation, yearly, and at major setup maintenance	Table 14.4.
Brake torque sensor	Upon initial installation, yearly, and at major setup maintenance	Table 14.4.
Brake pressure sensor	Upon initial installation, yearly, and at major setup maintenance	Table 14.4.
Brake fluid displacement	Upon initial installation, yearly, and at major setup maintenance	±0.5 per cent maximum
Temperature data acquisition	Upon initial installation, yearly, and at major setup maintenance	±0.25 per cent maximum

Table 14.4.

**Linearity requirements of rotational speed, brake torque, and brake pressure measurement devices**

<i>Measurement system</i>	<i>Intercept a0</i>	<i>Slope a1</i>	<i>Standard error of estimate (SEE)</i>	<i>Coefficient of determination r<sup>2</sup></i>
Brake Rotational Speed	≤ 0.05 per cent maximum	0.98 – 1.02	≤ 0.25 per cent maximum	≥ 0.990
Brake Torque	≤ 0.05 per cent maximum	0.98 – 1.02	≤ 0.5 per cent maximum	≥ 0.990
Brake pressure	≤ 0.05 per cent maximum	0.98 – 1.02	≤ 0.5 per cent maximum	≥ 0.990

Apart from the calibrations of the systems listed in Tables 14.3. and 14.4., the testing facility shall verify the torque zero level and pressure zero level every time before commencing a brake emissions test.

**14.3. Cooling Airflow Measurement Device**

The calibration of the flow measurement device used for the determination of the cooling airflow shall be traceable to national or international standards. The flow measurement device shall comply with the linearity requirements of Table 14.5. with at least four equally spaced reference flows applying a linear regression between the minimum and maximum applicable flow rate of the setup. In addition, each flow measurement point shall be within ±2 per cent of the measured reference flow. The testing facility shall perform the calibration of the airflow measurement device upon the initial installation, yearly, and at every major maintenance of the setup.

Table 14.5.

**Linearity requirements of the flow measurement device**

<i>Measurement system</i>	<i>Intercept a0</i>	<i>Slope a1</i>	<i>Standard error of estimate (SEE)</i>	<i>Coefficient of determination r<sup>2</sup></i>
Flow meter	≤ 1 per cent maximum	0.98 – 1.02	≤ 2 per cent maximum	≥ 0.990

The testing facility shall use a flow measurement device calibrated to report airflow at standard conditions. To ensure an appropriate conversion to operating conditions, the temperature sensor shall have an accuracy of ±1 °C and the pressure measurements shall have a precision and accuracy of ±0.4 kPa. The testing facility shall carry out the calibration of both sensors yearly.

#### 14.4. PM and Mass Loss Scales

##### 14.4.1. Microbalance for PM Filter Weighting

The calibration of the microgram balance used for PM mass filter weighing according to paragraph 12.1.4. shall be traceable to national or international standards. The balance shall comply with the linearity requirements of Table 14.6. with at least four equally spaced reference weights applying linear regression. This implies a precision of at least  $\pm 2 \mu\text{g}$  and a resolution of at least  $1 \mu\text{g}$  (1 digit =  $1 \mu\text{g}$ ). The testing facility shall use certified calibration weights to verify the stability and the proper function of the microbalance, regularly. The testing facility shall perform the calibration of the microgram balance upon the initial installation, yearly, and at every major maintenance of the setup.

##### 14.4.2. Balance for Brake Parts Weighting

The calibration of the balance used for the brake parts weighing according to paragraph 12.3. shall be traceable to national or international standards. The balance shall comply with the linearity requirements of Table 14.6. with at least four equally spaced reference weights applying linear regression. This implies a precision of at least  $\pm 1 \text{ g}$  and a resolution of at least  $0.1 \text{ g}$ . The testing facility shall use certified calibration weights to verify the stability and the proper function of the microbalance, regularly. The testing facility shall perform the calibration of the microgram balance upon the initial installation, yearly, and at every major maintenance of the setup.

Table 14.6.

#### Verification criteria for microgram balance

<i>Measurement system</i>	<i>Intercept a0</i>	<i>Slope a1</i>	<i>Standard error of estimate (SEE)</i>	<i>Coefficient of determination r<sup>2</sup></i>
PM balance	$\leq 1 \mu\text{g}$	0.99 – 1.01	$\leq 1$ per cent maximum	$\geq 0.998$
Brake parts balance	$\leq 0.3 \text{ g}$	0.99 – 1.01	$\leq 1$ per cent maximum	$\geq 0.998$

#### 14.5. Sample Treatment and Conditioning Devices

##### 14.5.1. Dilution System for TPN10 Measurement

The calibration of the dilution system's PCRf across its full range of dilution settings shall be carried out at the instrument's fixed nominal operating temperatures when the unit is new and following any major maintenance. The periodic validation requirement for the dilution system's PCRf shall be limited to a check at a single setting typical of that used for emissions testing of any typical brake available in the market. The Technical Service shall ensure the existence of a calibration or validation certificate within a 6-month period before the emissions test. A 13-month validation interval shall be permissible when the dilution system incorporates temperature monitoring alarms.

The dilution system shall be characterised for PCRf with thermally stable particles at the operating conditions of the system of 15 nm, 30 nm, 50 nm, and 100 nm electrical mobility diameters. PCRfs ( $f_r(d_x)$ ) for particles of 15 nm, 30 nm, and 50 nm electrical mobility diameters shall be no more than 100 per cent, 30 per cent, and 20 per cent higher respectively, and no more than 5 per cent lower than that for particles of 100 nm electrical mobility diameter. Table 14.7. summarizes the requirements for the PCRfs ( $f_r(d_x)$ ) for particles of 15 nm, 30 nm, and 50 nm electrical mobility diameters. For validation, the mean PCRf shall be within  $\pm 10$  per cent of the arithmetic mean particle concentration reduction factor ( $f_r$ ) determined during the primary calibration of the dilution system.



Table 14.7.

**PCRf ( $f_r(d_x)$ ) requirements for particles of 15 nm, 30 nm, and 50 nm electrical mobility diameters**

<i>PCRf Fraction</i>	<i>Minimum allowed value</i>	<i>Maximum allowed value</i>
(fr (15nm))/(fr (100nm))	0.95	2.00
(fr (30nm))/(fr (100nm))	0.95	1.30
(fr (50nm))/(fr (100nm))	0.95	1.20

The test aerosol for these measurements shall be thermally stable particles at the operating conditions of the system of 15, 30, 50, and 100 nm electrical mobility diameters. The minimum concentration at the dilution system inlet shall be 3000 #/cm<sup>3</sup> for particles of 15 nm electrical mobility diameter and 5000 #/cm<sup>3</sup> for particles of 30, 50, and 100 nm electrical mobility diameters. Particle concentrations shall be measured upstream and downstream of the components. The PCRf at each monodisperse particle size ( $f_r(d_x)$ ) shall be calculated following Equation 14.1.  $N_{in}(d_x)$  and  $N_{out}(d_x)$  shall refer to the same conditions (i.e. standard conditions):

$$f_r(d_x) = \frac{N_{in}(d_x)}{N_{out}(d_x)} \quad (\text{Eq. 14.1})$$

Where:

$N_{in}(d_x)$  is the upstream PN concentration for particles of electrical mobility diameter  $d_x$ ;

$N_{out}(d_x)$  is the downstream PN concentration for particles of electrical mobility diameter  $d_x$ .

The arithmetic average particle concentration reduction (fr) at a given dilution setting shall be calculated using Equation 14.2:

$$f_r = [f_r(30 \text{ nm}) + f_r(50 \text{ nm}) + f_r(100 \text{ nm})]/3 \quad (\text{Eq. 14.2})$$

Where:

$f_r(30 \text{ nm})$  is the PCRf for particles of 30 nm electrical mobility diameter;

$f_r(50 \text{ nm})$  is the PCRf for particles of 50 nm electrical mobility diameter;

$f_r(100 \text{ nm})$  is the PCRf for particles of 100 nm electrical mobility diameter.

The instrument manufacturer shall verify the particle penetration  $P_r(d_x)$  by testing one unit for each system model. A system model here covers all systems with the same hardware, i.e. same geometry, conduit materials, flows, and temperature profiles in the aerosol path. The particle penetration  $P_r(d_x)$  at a particle size,  $d_x$ , shall be calculated using Equation 14.3. DF is the dilution factor between measurement positions of  $N_{in}(d_x)$  and  $N_{out}(d_x)$  determined either with trace gases or flow measurements.

$$P_r(d_x) = DF \times N_{out}(d_x)/N_{in}(d_x) \quad (\text{Eq. 14.3})$$

#### 14.5.2. Volatile Particle Removal for SPN10 Measurement

The calibration of the VPR's PCRf across its full range of dilution settings shall be carried out at the instrument's fixed nominal operating temperatures when the unit is new and following any major maintenance. The periodic validation requirement for the VPR's PCRf shall be limited to a check at a single setting typical of that used for emissions testing of any typical brake available in the market. The Technical Service shall ensure the existence of a calibration or validation certificate within a 6-month period before the

emissions test. A 13-month validation interval shall be permissible when the VPR incorporates temperature monitoring alarms.

The VPR shall be characterised for PCRf with solid particles of 15 nm, 30 nm, 50 nm, and 100 nm electrical mobility diameters. PCRfs for particles of 15 nm, 30 nm, and 50 nm electrical mobility diameters shall be no more than 100 per cent, 30 per cent, and 20 per cent higher respectively, and no more than 5 per cent lower than that for particles of 100 nm electrical mobility diameter (Table 14.7.). For validation, the mean PCRf shall be within  $\pm 10$  per cent of the arithmetic mean particle concentration reduction factor ( $f_r$ ) determined during the last calibration of the VPR.

The test aerosol for these measurements shall be solid particles of 15 nm, 30 nm, 50 nm, and 100 nm electrical mobility diameters. The minimum concentration at the dilution system inlet shall be  $3000 \text{ \#/cm}^3$  for particles of 15 nm electrical mobility diameter and  $5000 \text{ \#/cm}^3$  for particles of 30 nm, 50 nm, and 100 nm electrical mobility diameters. Particle concentrations shall be measured upstream and downstream of the components. The PCRf at each monodisperse particle size ( $f_r(d_x)$ ) shall be calculated following Equation 14.1. The arithmetic average particle concentration reduction ( $f_r$ ) at a given dilution setting shall be calculated using Equation 14.2.

It is recommended that the VPR is calibrated and validated as a complete unit. The volatile particle removal efficiency of a VPR needs to be proven only once for the instrument family measuring SPN10. The instrument manufacturer must provide the maintenance or replacement interval that ensures that the removal efficiency of the VPR does not drop below the technical requirements. If such information is not provided, the volatile removal efficiency has to be checked yearly for each instrument.

The VPR used for SPN10 measurements shall demonstrate greater than 99.9 per cent removal efficiency of Tetracontane ( $\text{CH}_3(\text{CH}_2)_{38}\text{CH}_3$ ) particles with count median electrical mobility diameter  $> 50 \text{ nm}$  and mass  $> 1 \text{ mg/m}^3$  when operated at its minimum dilution setting and the manufacturers recommended operating temperature.

The instrument manufacturer shall prove the particle penetration  $P_r(d_x)$  by testing one unit for each system model. A system model here covers all systems with the same hardware, i.e. same geometry, conduit materials, flows, and temperature profiles in the aerosol path. The particle penetration  $P_r(d_x)$  at a particle size,  $d_x$ , shall be calculated using Equation 14.3.

#### 14.6. Particle Number Counter

The responsible authority shall ensure the existence of a calibration certificate for the PNC demonstrating compliance with a traceable standard within a 13-month period before the emissions test. Between calibrations, either the counting efficiency of the PNC shall be monitored for deterioration, or the PNC wick shall be routinely changed every 6 months if recommended by the instrument manufacturer. The PNC shall also be recalibrated and a new calibration certificate issued following any major maintenance.

Calibration shall be traceable to a standard calibration method. The testing facility shall use one of the two following methods for the calibration of the PNC:

- (a) Comparison of the response of the PNC under calibration with that of a calibrated aerosol electrometer when simultaneously sampling electrostatically classified calibration particles;
- (b) Comparison of the response of the PNC under calibration with that of a second PNC that has been directly calibrated by the above method.

The calibration shall be undertaken using at least six standard concentrations across the PNC's measurement range. Five of these standard concentrations shall be as uniformly spaced as possible between the standard concentration of 3000 #/cm<sup>3</sup> or below and the maximum of the PNC's range in single-particle count mode. The six standard concentration points shall include a nominal zero concentration point produced by attaching HEPA filters of at least Class H13 of EN 1822:2008 (or equivalent performance) to the inlet of each instrument. The gradient from a linear least-squares regression of the two data sets shall be calculated and recorded. A calibration factor equal to the reciprocal of the gradient shall be applied to the PNC under calibration. The linearity of response is calculated as the square of the Pearson product-moment correlation coefficient ( $r$ ) of the two data sets and shall be equal to or greater than 0.97. In calculating both the gradient and  $R^2$ , the linear regression shall be forced through the origin (zero concentration on both instruments). The calibration factor shall be between 0.9 and 1.1. Each concentration measured with the PNC under calibration shall be within  $\pm 5$  per cent of the measured reference concentration multiplied by the gradient, with the exception of the zero point.

The calibration shall also include a check against the requirements for the PNC's detection efficiency with particles of 10 nm electrical mobility diameter. A check of the counting efficiency with 15 nm particles is not required during periodical calibration.

## Annex A

## WLTP-Brake Cycle Events

Event time start [s]	Event time end [s]	Trip [#]	Event Type	Speed at start [km/h]	Speed at end [km/h]
0	4	1	Idle	0.0	0.0
4	10	1	Accel.	0.0	20.7
10	18	1	Cruise	20.7	20.7
18	24	1	Decel.	20.7	0.0
24	27	1	Idle	0.0	0.0
27	46	1	Accel.	0.0	23.1
46	58	1	Cruise	23.1	23.1
58	65	1	Decel.	23.1	5.6
65	68	1	Cruise	5.6	5.6
68	77	1	Accel.	5.6	15.4
77	85	1	Cruise	15.4	15.4
85	89	1	Decel.	15.4	4.4
89	92	1	Cruise	4.4	4.4
92	100	1	Accel.	4.4	25.7
100	103	1	Cruise	25.7	25.7
103	109	1	Decel.	25.7	7.2
109	112	1	Cruise	7.2	7.2
112	122	1	Accel.	7.2	24.8
122	129	1	Cruise	24.8	24.8
129	132	1	Decel.	24.8	16.7
132	135	1	Cruise	16.7	16.7
135	137	1	Accel.	16.7	18.7
137	140	1	Cruise	18.7	18.7
140	149	1	Decel.	18.7	0.0
149	153	1	Idle	0.0	0.0
153	174	1	Accel.	0.0	32.5
174	177	1	Cruise	32.5	32.5
177	183	1	Decel.	32.5	0.0
183	281	1	Idle	0.0	0.0
281	295	1	Accel.	0.0	27.5
295	298	1	Cruise	27.5	27.5
298	303	1	Decel.	27.5	11.8
303	306	1	Cruise	11.8	11.8
306	311	1	Accel.	11.8	29.4
311	314	1	Cruise	29.4	29.4
314	320	1	Decel.	29.4	9.7
320	323	1	Cruise	9.7	9.7
323	333	1	Accel.	9.7	31.9
333	341	1	Cruise	31.9	31.9

Event time start [s]	Event time end [s]	Trip [#]	Event Type	Speed at start [km/h]	Speed at end [km/h]
341	347	1	Decel.	31.9	9.5
347	351	1	Cruise	9.5	9.5
351	358	1	Accel.	9.5	14.7
358	361	1	Cruise	14.7	14.7
361	366	1	Decel.	14.7	0.0
366	372	1	Idle	0.0	0.0
372	381	1	Accel.	0.0	59.5
381	384	1	Cruise	59.5	59.5
384	388	1	Decel.	59.5	47.6
388	402	1	Cruise	47.6	47.6
402	406	1	Decel.	47.6	36.2
406	478	1	Cruise	36.2	36.2
478	480	1	Accel.	36.2	38.2
480	486	1	Cruise	38.2	38.2
486	490	1	Decel.	38.2	25.5
490	493	1	Cruise	25.5	25.5
493	496	1	Decel.	25.5	18.4
496	499	1	Cruise	18.4	18.4
499	505	1	Decel.	18.4	0.0
505	508	1	Idle	0.0	0.0
508	516	1	Accel.	0.0	42.3
516	543	1	Cruise	42.3	42.3
543	552	1	Decel.	42.3	0.0
552	555	1	Idle	0.0	0.0
555	564	1	Accel.	0.0	42.1
564	566	1	Cruise	42.1	42.1
566	576	1	Decel.	42.1	0.0
576	579	1	Idle	0.0	0.0
579	587	1	Accel.	0.0	31.3
587	592	1	Cruise	31.3	31.3
592	595	1	Decel.	31.3	12.5
595	600	1	Cruise	12.5	12.5
600	605	1	Decel.	12.5	0.0
605	622	1	Idle	0.0	0.0
622	642	1	Accel.	0.0	45.3
642	647	1	Cruise	45.3	45.3
647	657	1	Decel.	45.3	0.0
657	660	1	Idle	0.0	0.0
660	669	1	Accel.	0.0	45.5

Event time start [s]	Event time end [s]	Trip [#]	Event Type	Speed at start [km/h]	Speed at end [km/h]
669	673	1	Cruise	45.5	45.5
673	683	1	Decel.	45.5	0.0
683	685	1	Idle	0.0	0.0
685	704	1	Accel.	0.0	40.7
704	726	1	Cruise	40.7	40.7
726	733	1	Decel.	40.7	12.8
733	736	1	Cruise	12.8	12.8
736	744	1	Accel.	12.8	59.6
744	747	1	Cruise	59.6	59.6
747	751	1	Decel.	59.6	46.7
751	758	1	Cruise	46.7	46.7
758	759	1	Accel.	46.7	48.6
759	768	1	Cruise	48.6	48.6
768	777	1	Decel.	48.6	0.0
777	778	1	Idle	0.0	0.0
778	786	1	Accel.	0.0	23.7
786	941	1	Cruise	23.7	23.7
941	945	1	Decel.	23.7	9.8
945	948	1	Cruise	9.8	9.8
948	956	1	Accel.	9.8	37.5
956	974	1	Cruise	37.5	37.5
974	983	1	Decel.	37.5	0.0
983	986	1	Idle	0.0	0.0
986	993	1	Accel.	0.0	37.7
993	996	1	Cruise	37.7	37.7
996	1005	1	Decel.	37.7	0.0
1005	1008	1	Idle	0.0	0.0
1008	1013	1	Accel.	0.0	18.6
1013	1016	1	Cruise	18.6	18.6
1016	1021	1	Decel.	18.6	0.0
1021	1070	1	Idle	0.0	0.0
1070	1115	2	Idle	0.0	0.0
1115	1119	2	Accel.	0.0	13.8
1119	1122	2	Cruise	13.8	13.8
1122	1126	2	Decel.	13.8	0.0
1126	1129	2	Idle	0.0	0.0
1129	1144	2	Accel.	0.0	34.2
1144	1147	2	Cruise	34.2	34.2
1147	1151	2	Decel.	34.2	18.9
1151	1154	2	Cruise	18.9	18.9
1154	1162	2	Accel.	18.9	32.9
1162	1174	2	Cruise	32.9	32.9
1174	1178	2	Decel.	32.9	23.3

Event time start [s]	Event time end [s]	Trip [#]	Event Type	Speed at start [km/h]	Speed at end [km/h]
1178	1182	2	Cruise	23.3	23.3
1182	1186	2	Accel.	23.3	25.6
1186	1188	2	Cruise	25.6	25.6
1188	1191	2	Decel.	25.6	18.5
1191	1194	2	Cruise	18.5	18.5
1194	1206	2	Accel.	18.5	38.7
1206	1209	2	Cruise	38.7	38.7
1209	1217	2	Decel.	38.7	0.0
1217	1220	2	Idle	0.0	0.0
1220	1236	2	Accel.	0.0	48.4
1236	1253	2	Cruise	48.4	48.4
1253	1256	2	Decel.	48.4	40.6
1256	1259	2	Cruise	40.6	40.6
1259	1262	2	Accel.	40.6	42.4
1262	1282	2	Cruise	42.4	42.4
1282	1286	2	Decel.	42.4	30.3
1286	1290	2	Cruise	30.3	30.3
1290	1295	2	Decel.	30.3	13.7
1295	1298	2	Cruise	13.7	13.7
1298	1315	2	Accel.	13.7	40.0
1315	1319	2	Cruise	40.0	40.0
1319	1325	2	Decel.	40.0	20.0
1325	1328	2	Cruise	20.0	20.0
1328	1331	2	Accel.	20.0	29.7
1331	1334	2	Cruise	29.7	29.7
1334	1338	2	Decel.	29.7	18.9
1338	1341	2	Cruise	18.9	18.9
1341	1344	2	Accel.	18.9	24.5
1344	1448	2	Cruise	24.5	24.5
1448	1451	2	Decel.	24.5	17.5
1451	1454	2	Cruise	17.5	17.5
1454	1476	2	Accel.	17.5	42.0
1476	1482	2	Cruise	42.0	42.0
1482	1491	2	Decel.	42.0	0.0
1491	1502	2	Idle	0.0	0.0
1502	1512	2	Accel.	0.0	22.0
1512	1515	2	Cruise	22.0	22.0
1515	1519	2	Decel.	22.0	11.8
1519	1522	2	Cruise	11.8	11.8
1522	1528	2	Accel.	11.8	32.4
1528	1539	2	Cruise	32.4	32.4
1539	1547	2	Decel.	32.4	6.1
1547	1550	2	Cruise	6.1	6.1

Event time start [s]	Event time end [s]	Trip [#]	Event Type	Speed at start [km/h]	Speed at end [km/h]
1550	1559	2	Accel.	6.1	34.8
1559	1597	2	Cruise	34.8	34.8
1597	1605	2	Decel.	34.8	0.0
1605	1608	2	Idle	0.0	0.0
1608	1624	2	Accel.	0.0	76.1
1624	1662	2	Cruise	76.1	76.1
1662	1675	2	Decel.	76.1	0.0
1675	1678	2	Idle	0.0	0.0
1678	1686	2	Accel.	0.0	22.8
1686	1689	2	Cruise	22.8	22.8
1689	1694	2	Decel.	22.8	0.0
1694	1697	2	Idle	0.0	0.0
1697	1707	2	Accel.	0.0	41.6
1707	1753	2	Cruise	41.6	41.6
1753	1757	2	Decel.	41.6	27.2
1757	1763	2	Cruise	27.2	27.2
1763	1773	2	Accel.	27.2	47.9
1773	1804	2	Cruise	47.9	47.9
1804	1807	2	Decel.	47.9	35.2
1807	1823	2	Cruise	35.2	35.2
1823	1828	2	Decel.	35.2	20.1
1828	1831	2	Cruise	20.1	20.1
1831	1843	2	Accel.	20.1	59.2
1843	1870	2	Cruise	59.2	59.2
1870	1873	2	Decel.	59.2	49.5
1873	1876	2	Cruise	49.5	49.5
1876	1885	2	Accel.	49.5	72.9
1885	1895	2	Cruise	72.9	72.9
1895	1898	2	Decel.	72.9	62.0
1898	1901	2	Cruise	62.0	62.0
1901	1904	2	Accel.	62.0	66.4
1904	1907	2	Cruise	66.4	66.4
1907	1910	2	Decel.	66.4	57.4
1910	1913	2	Cruise	57.4	57.4
1913	1915	2	Accel.	57.4	60.0
1915	1918	2	Cruise	60.0	60.0
1918	1921	2	Decel.	60.0	52.1
1921	1937	2	Cruise	52.1	52.1
1937	1947	2	Accel.	52.1	79.7
1947	1951	2	Cruise	79.7	79.7
1951	1954	2	Decel.	79.7	72.1
1954	1959	2	Cruise	72.1	72.1
1959	1960	2	Accel.	72.1	74.0

Event time start [s]	Event time end [s]	Trip [#]	Event Type	Speed at start [km/h]	Speed at end [km/h]
1960	1972	2	Cruise	74.0	74.0
1972	1978	2	Decel.	74.0	52.4
1978	2062	2	Cruise	52.4	52.4
2062	2074	2	Decel.	52.4	0.0
2074	2077	2	Idle	0.0	0.0
2077	2093	2	Accel.	0.0	60.3
2093	2123	2	Cruise	60.3	60.3
2123	2133	2	Decel.	60.3	0.0
2133	2137	2	Idle	0.0	0.0
2137	2152	2	Accel.	0.0	62.9
2152	2187	2	Cruise	62.9	62.9
2187	2195	2	Decel.	62.9	0.0
2195	2199	2	Idle	0.0	0.0
2199	2212	2	Accel.	0.0	60.1
2212	2218	2	Cruise	60.1	60.1
2218	2229	2	Decel.	60.1	15.2
2229	2233	2	Cruise	15.2	15.2
2233	2244	2	Accel.	15.2	53.3
2244	2250	2	Cruise	53.3	53.3
2250	2261	2	Decel.	53.3	0.0
2261	2266	2	Idle	0.0	0.0
2266	2272	2	Accel.	0.0	20.7
2272	2520	2	Cruise	20.7	20.7
2520	2526	2	Decel.	20.7	0.0
2526	2529	2	Idle	0.0	0.0
2529	2548	2	Accel.	0.0	23.1
2548	2560	2	Cruise	23.1	23.1
2560	2567	2	Decel.	23.1	5.6
2567	2570	2	Cruise	5.6	5.6
2570	2579	2	Accel.	5.6	15.4
2579	2587	2	Cruise	15.4	15.4
2587	2591	2	Decel.	15.4	4.4
2591	2594	2	Cruise	4.4	4.4
2594	2602	2	Accel.	4.4	25.7
2602	2605	2	Cruise	25.7	25.7
2605	2611	2	Decel.	25.7	7.2
2611	2614	2	Cruise	7.2	7.2
2614	2624	2	Accel.	7.2	24.8
2624	2631	2	Cruise	24.8	24.8
2631	2634	2	Decel.	24.8	16.7
2634	2637	2	Cruise	16.7	16.7
2637	2639	2	Accel.	16.7	18.7
2639	2642	2	Cruise	18.7	18.7

Event time start [s]	Event time end [s]	Trip [#]	Event Type	Speed at start [km/h]	Speed at end [km/h]
2642	2650	2	Decel.	18.7	0.0
2650	2655	2	Idle	0.0	0.0
2655	2669	2	Accel.	0.0	46.6
2669	2672	2	Cruise	46.6	46.6
2672	2677	2	Decel.	46.6	9.4
2677	2680	2	Cruise	9.4	9.4
2680	2690	2	Accel.	9.4	52.0
2690	2698	2	Cruise	52.0	52.0
2698	2701	2	Decel.	52.0	41.5
2701	2704	2	Cruise	41.5	41.5
2704	2708	2	Accel.	41.5	49.9
2708	2714	2	Cruise	49.9	49.9
2714	2719	2	Decel.	49.9	34.0
2719	2722	2	Cruise	34.0	34.0
2722	2728	2	Accel.	34.0	49.0
2728	2738	2	Cruise	49.0	49.0
2738	2745	2	Decel.	49.0	23.8
2745	2748	2	Cruise	23.8	23.8
2748	2754	2	Accel.	23.8	41.6
2754	2759	2	Cruise	41.6	41.6
2759	2767	2	Decel.	41.6	0.0
2767	2835	2	Idle	0.0	0.0
2835	2883	3	Idle	0.0	0.0
2883	2892	3	Accel.	0.0	32.1
2892	2897	3	Cruise	32.1	32.1
2897	2903	3	Decel.	32.1	5.5
2903	2906	3	Cruise	5.5	5.5
2906	2924	3	Accel.	5.5	50.5
2924	2946	3	Cruise	50.5	50.5
2946	2949	3	Decel.	50.5	42.8
2949	2952	3	Cruise	42.8	42.8
2952	2955	3	Accel.	42.8	45.0
2955	2958	3	Cruise	45.0	45.0
2958	2963	3	Decel.	45.0	29.8
2963	2966	3	Cruise	29.8	29.8
2966	2971	3	Decel.	29.8	0.0
2971	2976	3	Idle	0.0	0.0
2976	3001	3	Accel.	0.0	49.2
3001	3006	3	Cruise	49.2	49.2
3006	3011	3	Decel.	49.2	33.1
3011	3014	3	Cruise	33.1	33.1
3014	3025	3	Accel.	33.1	56.2
3025	3032	3	Cruise	56.2	56.2

Event time start [s]	Event time end [s]	Trip [#]	Event Type	Speed at start [km/h]	Speed at end [km/h]
3032	3036	3	Decel.	56.2	44.0
3036	3039	3	Cruise	44.0	44.0
3039	3049	3	Accel.	44.0	59.0
3049	3053	3	Cruise	59.0	59.0
3053	3056	3	Decel.	59.0	51.2
3056	3059	3	Cruise	51.2	51.2
3059	3062	3	Accel.	51.2	55.0
3062	3078	3	Cruise	55.0	55.0
3078	3081	3	Decel.	55.0	47.5
3081	3084	3	Cruise	47.5	47.5
3084	3093	3	Accel.	47.5	59.5
3093	3096	3	Cruise	59.5	59.5
3096	3101	3	Decel.	59.5	39.9
3101	3159	3	Cruise	39.9	39.9
3159	3165	3	Decel.	39.9	14.2
3165	3168	3	Cruise	14.2	14.2
3168	3192	3	Accel.	14.2	58.3
3192	3195	3	Cruise	58.3	58.3
3195	3201	3	Decel.	58.3	34.8
3201	3257	3	Cruise	34.8	34.8
3257	3261	3	Accel.	34.8	39.5
3261	3268	3	Cruise	39.5	39.5
3268	3271	3	Decel.	39.5	30.0
3271	3274	3	Cruise	30.0	30.0
3274	3292	3	Accel.	30.0	56.2
3292	3308	3	Cruise	56.2	56.2
3308	3311	3	Decel.	56.2	46.0
3311	3314	3	Cruise	46.0	46.0
3314	3318	3	Accel.	46.0	54.4
3318	3418	3	Cruise	54.4	54.4
3418	3422	3	Decel.	54.4	40.4
3422	3432	3	Cruise	40.4	40.4
3432	3438	3	Accel.	40.4	53.5
3438	3441	3	Cruise	53.5	53.5
3441	3445	3	Decel.	53.5	40.8
3445	3480	3	Cruise	40.8	40.8
3480	3483	3	Decel.	40.8	32.0
3483	3486	3	Cruise	32.0	32.0
3486	3489	3	Accel.	32.0	34.7
3489	3492	3	Cruise	34.7	34.7
3492	3495	3	Decel.	34.7	26.4
3495	3498	3	Cruise	26.4	26.4
3498	3514	3	Accel.	26.4	50.6

Event time start [s]	Event time end [s]	Trip [#]	Event Type	Speed at start [km/h]	Speed at end [km/h]
3514	3557	3	Cruise	50.6	50.6
3557	3561	3	Decel.	50.6	37.6
3561	3621	3	Cruise	37.6	37.6
3621	3626	3	Decel.	37.6	22.4
3626	3629	3	Cruise	22.4	22.4
3629	3640	3	Accel.	22.4	36.8
3640	3647	3	Cruise	36.8	36.8
3647	3651	3	Decel.	36.8	22.9
3651	3654	3	Cruise	22.9	22.9
3654	3675	3	Accel.	22.9	55.3
3675	3684	3	Cruise	55.3	55.3
3684	3688	3	Decel.	55.3	39.5
3688	3692	3	Cruise	39.5	39.5
3692	3698	3	Decel.	39.5	15.5
3698	3701	3	Cruise	15.5	15.5
3701	3717	3	Accel.	15.5	44.3
3717	3729	3	Cruise	44.3	44.3
3729	3732	3	Decel.	44.3	36.6
3732	3773	3	Cruise	36.6	36.6
3773	3778	3	Decel.	36.6	20.8
3778	3796	3	Cruise	20.8	20.8
3796	3802	3	Accel.	20.8	32.0
3802	3849	3	Cruise	32.0	32.0
3849	3852	3	Decel.	32.0	24.8
3852	3855	3	Cruise	24.8	24.8
3855	3875	3	Accel.	24.8	51.6
3875	3879	3	Cruise	51.6	51.6
3879	3883	3	Decel.	51.6	39.3
3883	3895	3	Cruise	39.3	39.3
3895	3898	3	Decel.	39.3	32.4
3898	3939	3	Cruise	32.4	32.4
3939	3946	3	Decel.	32.4	0.0
3946	3947	3	Idle	0.0	0.0
3947	3949	4	Idle	0.0	0.0
3949	3966	4	Accel.	0.0	75.8
3966	4001	4	Cruise	75.8	75.8
4001	4005	4	Decel.	75.8	63.9
4005	4081	4	Cruise	63.9	63.9
4081	4086	4	Accel.	63.9	72.4
4086	4089	4	Cruise	72.4	72.4
4089	4093	4	Decel.	72.4	58.7
4093	4096	4	Cruise	58.7	58.7
4096	4104	4	Accel.	58.7	65.9

Event time start [s]	Event time end [s]	Trip [#]	Event Type	Speed at start [km/h]	Speed at end [km/h]
4104	4118	4	Cruise	65.9	65.9
4118	4122	4	Decel.	65.9	53.7
4122	4136	4	Cruise	53.7	53.7
4136	4137	4	Accel.	53.7	54.9
4137	4147	4	Cruise	54.9	54.9
4147	4157	4	Decel.	54.9	0.0
4157	4164	4	Idle	0.0	0.0
4164	4196	4	Accel.	0.0	90.6
4196	4551	4	Cruise	90.6	90.6
4551	4566	4	Decel.	90.6	0.0
4566	4570	4	Idle	0.0	0.0
4570	4578	4	Accel.	0.0	33.0
4578	4586	4	Cruise	33.0	33.0
4586	4601	4	Accel.	33.0	75.0
4601	4612	4	Cruise	75.0	75.0
4612	4619	4	Accel.	75.0	80.3
4619	4635	4	Cruise	80.3	80.3
4635	4653	4	Accel.	80.3	95.6
4653	4668	4	Cruise	95.6	95.6
4668	4683	4	Decel.	95.6	25.5
4683	4688	4	Cruise	25.5	25.5
4688	4714	4	Accel.	25.5	98.4
4714	5004	4	Cruise	98.4	98.4
5004	5019	4	Decel.	98.4	0.0
5019	5022	4	Idle	0.0	0.0
5022	5060	4	Accel.	0.0	82.8
5060	5071	4	Cruise	82.8	82.8
5071	5076	4	Decel.	82.8	69.4
5076	5135	4	Cruise	69.4	69.4
5135	5149	4	Decel.	69.4	10.1
5149	5152	4	Cruise	10.1	10.1
5152	5170	4	Accel.	10.1	69.0
5170	5190	4	Cruise	69.0	69.0
5190	5193	4	Decel.	69.0	61.7
5193	5290	4	Cruise	61.7	61.7
5290	5293	4	Accel.	61.7	64.7
5293	5297	4	Cruise	64.7	64.7
5297	5300	4	Decel.	64.7	57.8
5300	5314	4	Cruise	57.8	57.8
5314	5326	4	Decel.	57.8	0.0
5326	5336	4	Idle	0.0	0.0
5336	5342	4	Accel.	0.0	20.7
5342	5350	4	Cruise	20.7	20.7



Event time start [s]	Event time end [s]	Trip [#]	Event Type	Speed at start [km/h]	Speed at end [km/h]
5350	5356	4	Decel.	20.7	0.0
5356	5359	4	Idle	0.0	0.0
5359	5378	4	Accel.	0.0	23.1
5378	5390	4	Cruise	23.1	23.1
5390	5397	4	Decel.	23.1	5.6
5397	5400	4	Cruise	5.6	5.6
5400	5409	4	Accel.	5.6	15.4
5409	5417	4	Cruise	15.4	15.4
5417	5421	4	Decel.	15.4	4.4
5421	5424	4	Cruise	4.4	4.4
5424	5432	4	Accel.	4.4	25.7
5432	5435	4	Cruise	25.7	25.7
5435	5441	4	Decel.	25.7	7.2
5441	5444	4	Cruise	7.2	7.2
5444	5454	4	Accel.	7.2	24.8
5454	5461	4	Cruise	24.8	24.8
5461	5464	4	Decel.	24.8	16.7
5464	5467	4	Cruise	16.7	16.7
5467	5469	4	Accel.	16.7	18.7
5469	5472	4	Cruise	18.7	18.7
5472	5480	4	Decel.	18.7	0.0
5480	5484	4	Idle	0.0	0.0
5484	5488	5	Idle	0.0	0.0
5488	5496	5	Accel.	0.0	41.8
5496	5514	5	Cruise	41.8	41.8
5514	5524	5	Decel.	41.8	0.0
5524	5527	5	Idle	0.0	0.0
5527	5542	5	Accel.	0.0	34.6
5542	5554	5	Cruise	34.6	34.6
5554	5557	5	Decel.	34.6	27.3
5557	5560	5	Cruise	27.3	27.3
5560	5568	5	Accel.	27.3	43.5
5568	5571	5	Cruise	43.5	43.5
5571	5581	5	Decel.	43.5	0.0
5581	5587	5	Idle	0.0	0.0
5587	5601	5	Accel.	0.0	30.0
5601	5624	5	Cruise	30.0	30.0
5624	5629	5	Decel.	30.0	13.6
5629	5632	5	Cruise	13.6	13.6
5632	5639	5	Accel.	13.6	37.0
5639	5647	5	Cruise	37.0	37.0
5647	5656	5	Decel.	37.0	0.0
5656	5713	5	Idle	0.0	0.0

Event time start [s]	Event time end [s]	Trip [#]	Event Type	Speed at start [km/h]	Speed at end [km/h]
5713	5734	5	Accel.	0.0	41.2
5734	5749	5	Cruise	41.2	41.2
5749	5753	5	Decel.	41.2	29.5
5753	5789	5	Cruise	29.5	29.5
5789	5792	5	Decel.	29.5	18.0
5792	5795	5	Cruise	18.0	18.0
5795	5800	5	Decel.	18.0	0.0
5800	5803	5	Idle	0.0	0.0
5803	5811	5	Accel.	0.0	29.5
5811	5814	5	Cruise	29.5	29.5
5814	5817	5	Decel.	29.5	22.1
5817	5820	5	Cruise	22.1	22.1
5820	5824	5	Decel.	22.1	8.1
5824	5827	5	Cruise	8.1	8.1
5827	5832	5	Accel.	8.1	16.9
5832	5844	5	Cruise	16.9	16.9
5844	5849	5	Decel.	16.9	0.0
5849	5952	5	Idle	0.0	0.0
5952	5958	5	Accel.	0.0	14.4
5958	5965	5	Cruise	14.4	14.4
5965	5968	5	Decel.	14.4	3.5
5968	5971	5	Cruise	3.5	3.5
5971	6010	5	Accel.	3.5	56.4
6010	6074	5	Cruise	56.4	56.4
6074	6078	5	Decel.	56.4	41.2
6078	6081	5	Cruise	41.2	41.2
6081	6088	5	Decel.	41.2	13.9
6088	6091	5	Cruise	13.9	13.9
6091	6111	5	Accel.	13.9	56.4
6111	6175	5	Cruise	56.4	56.4
6175	6180	5	Decel.	56.4	41.3
6180	6183	5	Cruise	41.3	41.3
6183	6200	5	Accel.	41.3	58.0
6200	6208	5	Cruise	58.0	58.0
6208	6213	5	Decel.	58.0	39.6
6213	6248	5	Cruise	39.6	39.6
6248	6252	5	Decel.	39.6	22.3
6252	6255	5	Cruise	22.3	22.3
6255	6258	5	Accel.	22.3	26.7
6258	6320	5	Cruise	26.7	26.7
6320	6330	5	Decel.	26.7	0.0
6330	6339	5	Idle	0.0	0.0
6339	6425	5	Accel.	0.0	105.2

Event time start [s]	Event time end [s]	Trip [#]	Event Type	Speed at start [km/h]	Speed at end [km/h]
6425	6872	5	Cruise	105.2	105.2
6872	6876	5	Decel.	105.2	90.4
6876	6884	5	Cruise	90.4	90.4
6884	6893	5	Accel.	90.4	102.2
6893	6898	5	Cruise	102.2	102.2
6898	6901	5	Decel.	102.2	91.6
6901	6923	5	Cruise	91.6	91.6
6923	6926	5	Accel.	91.6	94.6
6926	6930	5	Cruise	94.6	94.6
6930	6932	5	Decel.	94.6	87.2
6932	6953	5	Cruise	87.2	87.2
6953	6957	5	Decel.	87.2	72.3
6957	6960	5	Cruise	72.3	72.3
6960	6973	5	Accel.	72.3	84.8
6973	6977	5	Cruise	84.8	84.8
6977	6981	5	Decel.	84.8	73.8
6981	6985	5	Cruise	73.8	73.8
6985	6995	5	Accel.	73.8	87.8
6995	6999	5	Cruise	87.8	87.8
6999	7005	5	Decel.	87.8	69.0
7005	7069	5	Cruise	69.0	69.0
7069	7074	5	Decel.	69.0	50.2
7074	7090	5	Cruise	50.2	50.2
7090	7104	5	Accel.	50.2	83.5
7104	7114	5	Cruise	83.5	83.5
7114	7117	5	Decel.	83.5	71.3
7117	7177	5	Cruise	71.3	71.3
7177	7182	5	Decel.	71.3	53.5
7182	7185	5	Cruise	53.5	53.5
7185	7198	5	Accel.	53.5	80.0
7198	7201	5	Cruise	80.0	80.0
7201	7205	5	Decel.	80.0	66.0
7205	7346	5	Cruise	66.0	66.0
7346	7349	5	Decel.	66.0	56.7
7349	7354	5	Cruise	56.7	56.7
7354	7368	5	Accel.	56.7	83.9
7368	7381	5	Cruise	83.9	83.9
7381	7388	5	Decel.	83.9	42.5
7388	7400	5	Cruise	42.5	42.5
7400	7414	5	Accel.	42.5	73.8
7414	7442	5	Cruise	73.8	73.8
7442	7455	5	Decel.	73.8	24.4
7455	7490	5	Cruise	24.4	24.4

Event time start [s]	Event time end [s]	Trip [#]	Event Type	Speed at start [km/h]	Speed at end [km/h]
7490	7496	5	Decel.	24.4	0.0
7496	7503	5	Idle	0.0	0.0
7503	7509	5	Accel.	0.0	22.9
7509	7518	5	Cruise	22.9	22.9
7518	7522	5	Decel.	22.9	13.5
7522	7525	5	Cruise	13.5	13.5
7525	7531	5	Accel.	13.5	23.0
7531	7534	5	Cruise	23.0	23.0
7534	7537	5	Decel.	23.0	15.4
7537	7540	5	Cruise	15.4	15.4
7540	7545	5	Accel.	15.4	19.0
7545	7548	5	Cruise	19.0	19.0
7548	7551	5	Decel.	19.0	12.2
7551	7554	5	Cruise	12.2	12.2
7554	7558	5	Accel.	12.2	18.8
7558	7561	5	Cruise	18.8	18.8
7561	7567	5	Decel.	18.8	0.0
7567	7688	5	Idle	0.0	0.0
7688	7699	5	Accel.	0.0	37.9
7699	7704	5	Cruise	37.9	37.9
7704	7709	5	Decel.	37.9	24.4
7709	7748	5	Cruise	24.4	24.4
7748	7752	5	Decel.	24.4	14.9
7752	7755	5	Cruise	14.9	14.9
7755	7764	5	Accel.	14.9	45.3
7764	7769	5	Cruise	45.3	45.3
7769	7774	5	Decel.	45.3	25.9
7774	7777	5	Cruise	25.9	25.9
7777	7787	5	Accel.	25.9	40.6
7787	7795	5	Cruise	40.6	40.6
7795	7800	5	Decel.	40.6	25.4
7800	7803	5	Cruise	25.4	25.4
7803	7814	5	Accel.	25.4	37.2
7814	7817	5	Cruise	37.2	37.2
7817	7822	5	Decel.	37.2	20.8
7822	7825	5	Cruise	20.8	20.8
7825	7829	5	Accel.	20.8	26.3
7829	7883	5	Cruise	26.3	26.3
7883	7889	5	Decel.	26.3	0.0
7889	7892	5	Idle	0.0	0.0
7892	7904	5	Accel.	0.0	53.4
7904	7907	5	Cruise	53.4	53.4
7907	7913	5	Decel.	53.4	28.2

Event time start [s]	Event time end [s]	Trip [#]	Event Type	Speed at start [km/h]	Speed at end [km/h]
7913	7916	5	Cruise	28.2	28.2
7916	7926	5	Accel.	28.2	42.6
7926	7941	5	Cruise	42.6	42.6
7941	7947	5	Decel.	42.6	19.0
7947	7950	5	Cruise	19.0	19.0
7950	7962	5	Accel.	19.0	57.1
7962	7973	5	Cruise	57.1	57.1
7973	7979	5	Decel.	57.1	31.8
7979	7982	5	Cruise	31.8	31.8
7982	7988	5	Accel.	31.8	50.0
7988	8064	5	Cruise	50.0	50.0
8064	8069	5	Decel.	50.0	24.4
8069	8072	5	Cruise	24.4	24.4
8072	8078	5	Accel.	24.4	58.2
8078	8081	5	Cruise	58.2	58.2
8081	8088	5	Decel.	58.2	29.9
8088	8120	5	Cruise	29.9	29.9
8120	8123	5	Decel.	29.9	21.2
8123	8126	5	Cruise	21.2	21.2
8126	8129	5	Accel.	21.2	25.0
8129	8162	5	Cruise	25.0	25.0
8162	8165	5	Accel.	25.0	32.6
8165	8168	5	Cruise	32.6	32.6
8168	8174	5	Decel.	32.6	0.0
8174	8175	5	Idle	0.0	0.0
8175	8177	6	Idle	0.0	0.0
8177	8189	6	Accel.	0.0	21.2
8189	8413	6	Cruise	21.2	21.2
8413	8418	6	Decel.	21.2	9.5
8418	8421	6	Cruise	9.5	9.5
8421	8425	6	Decel.	9.5	0.0
8425	8483	6	Idle	0.0	0.0
8483	8540	7	Idle	0.0	0.0
8540	8547	7	Accel.	0.0	35.1
8547	8552	7	Cruise	35.1	35.1
8552	8560	7	Decel.	35.1	5.5
8560	8563	7	Cruise	5.5	5.5
8563	8577	7	Accel.	5.5	16.5
8577	8609	7	Cruise	16.5	16.5
8609	8614	7	Decel.	16.5	0.0
8614	8625	7	Idle	0.0	0.0
8625	8670	7	Accel.	0.0	96.9
8670	9081	7	Cruise	96.9	96.9

Event time start [s]	Event time end [s]	Trip [#]	Event Type	Speed at start [km/h]	Speed at end [km/h]
9081	9089	7	Decel.	96.9	73.3
9089	9117	7	Cruise	73.3	73.3
9117	9127	7	Decel.	73.3	20.1
9127	9130	7	Cruise	20.1	20.1
9130	9143	7	Accel.	20.1	62.2
9143	9146	7	Cruise	62.2	62.2
9146	9155	7	Decel.	62.2	6.6
9155	9158	7	Cruise	6.6	6.6
9158	9171	7	Accel.	6.6	53.2
9171	9174	7	Cruise	53.2	53.2
9174	9187	7	Decel.	53.2	0.0
9187	9188	7	Idle	0.0	0.0
9188	9190	8	Idle	0.0	0.0
9190	9238	8	Accel.	0.0	83.6
9238	9264	8	Cruise	83.6	83.6
9264	9279	8	Decel.	83.6	0.0
9279	9366	8	Idle	0.0	0.0
9366	9372	8	Accel.	0.0	23.9
9372	9375	8	Cruise	23.9	23.9
9375	9382	8	Decel.	23.9	0.0
9382	9386	8	Idle	0.0	0.0
9386	9402	8	Accel.	0.0	65.3
9402	9427	8	Cruise	65.3	65.3
9427	9439	8	Decel.	65.3	0.0
9439	9443	8	Idle	0.0	0.0
9443	9453	8	Accel.	0.0	40.5
9453	9489	8	Cruise	40.5	40.5
9489	9493	8	Decel.	40.5	29.3
9493	9496	8	Cruise	29.3	29.3
9496	9516	8	Accel.	29.3	63.0
9516	9812	8	Cruise	63.0	63.0
9812	9815	8	Decel.	63.0	52.2
9815	9845	8	Cruise	52.2	52.2
9845	9848	8	Decel.	52.2	44.6
9848	9851	8	Cruise	44.6	44.6
9851	9859	8	Accel.	44.6	59.2
9859	9864	8	Cruise	59.2	59.2
9864	9869	8	Decel.	59.2	45.2
9869	9872	8	Cruise	45.2	45.2
9872	9876	8	Accel.	45.2	53.9
9876	9888	8	Cruise	53.9	53.9
9888	9898	8	Decel.	53.9	0.0
9898	9899	8	Idle	0.0	0.0

Event time start [s]	Event time end [s]	Trip [#]	Event Type	Speed at start [km/h]	Speed at end [km/h]
9899	9901	9	Idle	0.0	0.0
9901	9909	9	Accel.	0.0	19.1
9909	10036	9	Cruise	19.1	19.1
10036	10041	9	Decel.	19.1	6.4
10041	10044	9	Cruise	6.4	6.4
10044	10046	9	Accel.	6.4	10.5
10046	10049	9	Cruise	10.5	10.5
10049	10054	9	Decel.	10.5	0.0
10054	10056	9	Idle	0.0	0.0
10056	10066	9	Accel.	0.0	29.6
10066	10273	9	Cruise	29.6	29.6
10273	10280	9	Decel.	29.6	0.0
10280	10284	9	Idle	0.0	0.0
10284	10294	9	Accel.	0.0	24.3
10294	10453	9	Cruise	24.3	24.3
10453	10458	9	Decel.	24.3	4.5
10458	10461	9	Cruise	4.5	4.5
10461	10469	9	Accel.	4.5	27.8
10469	10475	9	Cruise	27.8	27.8
10475	10479	9	Decel.	27.8	17.3
10479	10482	9	Cruise	17.3	17.3
10482	10486	9	Decel.	17.3	6.5
10486	10489	9	Cruise	6.5	6.5
10489	10496	9	Accel.	6.5	26.8
10496	10507	9	Cruise	26.8	26.8
10507	10514	9	Decel.	26.8	0.0
10514	10554	9	Idle	0.0	0.0
10554	10626	10	Idle	0.0	0.0
10626	10632	10	Accel.	0.0	27.5
10632	10638	10	Cruise	27.5	27.5
10638	10647	10	Decel.	27.5	0.0
10647	10650	10	Idle	0.0	0.0
10650	10663	10	Accel.	0.0	39.0
10663	10696	10	Cruise	39.0	39.0
10696	10700	10	Decel.	39.0	29.0
10700	10707	10	Cruise	29.0	29.0
10707	10712	10	Accel.	29.0	35.1
10712	10721	10	Cruise	35.1	35.1
10721	10725	10	Decel.	35.1	24.5
10725	10728	10	Cruise	24.5	24.5
10728	10737	10	Accel.	24.5	41.9
10737	10758	10	Cruise	41.9	41.9
10758	10761	10	Decel.	41.9	34.1

Event time start [s]	Event time end [s]	Trip [#]	Event Type	Speed at start [km/h]	Speed at end [km/h]
10761	10764	10	Cruise	34.1	34.1
10764	10768	10	Accel.	34.1	39.4
10768	10792	10	Cruise	39.4	39.4
10792	10797	10	Decel.	39.4	24.9
10797	10800	10	Cruise	24.9	24.9
10800	10808	10	Accel.	24.9	36.4
10808	10811	10	Cruise	36.4	36.4
10811	10822	10	Decel.	36.4	0.0
10822	10825	10	Idle	0.0	0.0
10825	10838	10	Accel.	0.0	55.7
10838	10868	10	Cruise	55.7	55.7
10868	10879	10	Decel.	55.7	0.0
10879	10888	10	Idle	0.0	0.0
10888	10901	10	Accel.	0.0	56.2
10901	11088	10	Cruise	56.2	56.2
11088	11101	10	Decel.	56.2	0.0
11101	11104	10	Idle	0.0	0.0
11104	11114	10	Accel.	0.0	43.6
11114	11117	10	Cruise	43.6	43.6
11117	11126	10	Decel.	43.6	0.0
11126	11238	10	Idle	0.0	0.0
11238	11242	10	Accel.	0.0	11.2
11242	11245	10	Cruise	11.2	11.2
11245	11249	10	Decel.	11.2	4.1
11249	11252	10	Cruise	4.1	4.1
11252	11258	10	Accel.	4.1	15.0
11258	11261	10	Cruise	15.0	15.0
11261	11265	10	Decel.	15.0	6.2
11265	11268	10	Cruise	6.2	6.2
11268	11273	10	Accel.	6.2	10.1
11273	11276	10	Cruise	10.1	10.1
11276	11281	10	Decel.	10.1	0.0
11281	11284	10	Idle	0.0	0.0
11284	11293	10	Accel.	0.0	31.3
11293	11313	10	Cruise	31.3	31.3
11313	11316	10	Decel.	31.3	23.8
11316	11348	10	Cruise	23.8	23.8
11348	11351	10	Decel.	23.8	16.9
11351	11354	10	Cruise	16.9	16.9
11354	11361	10	Decel.	16.9	0.0
11361	11364	10	Idle	0.0	0.0
11364	11373	10	Accel.	0.0	40.0
11373	11512	10	Cruise	40.0	40.0

Event time start [s]	Event time end [s]	Trip [#]	Event Type	Speed at start [km/h]	Speed at end [km/h]
11512	11519	10	Decel.	40.0	10.6
11519	11522	10	Cruise	10.6	10.6
11522	11528	10	Accel.	10.6	15.6
11528	11541	10	Cruise	15.6	15.6
11541	11545	10	Decel.	15.6	6.3
11545	11548	10	Cruise	6.3	6.3
11548	11552	10	Accel.	6.3	15.6
11552	11557	10	Cruise	15.6	15.6
11557	11560	10	Decel.	15.6	8.8
11560	11563	10	Cruise	8.8	8.8
11563	11567	10	Accel.	8.8	13.1
11567	11574	10	Cruise	13.1	13.1
11574	11579	10	Decel.	13.1	0.0
11579	11646	10	Idle	0.0	0.0
11646	11652	10	Accel.	0.0	23.1
11652	11659	10	Cruise	23.1	23.1
11659	11662	10	Decel.	23.1	15.0
11662	11665	10	Cruise	15.0	15.0
11665	11666	10	Accel.	15.0	18.1
11666	11669	10	Cruise	18.1	18.1
11669	11671	10	Decel.	18.1	13.6
11671	11674	10	Cruise	13.6	13.6
11674	11680	10	Accel.	13.6	19.4
11680	11684	10	Cruise	19.4	19.4
11684	11687	10	Decel.	19.4	11.5
11687	11690	10	Cruise	11.5	11.5
11690	11694	10	Decel.	11.5	0.0
11694	11830	10	Idle	0.0	0.0
11830	11842	10	Accel.	0.0	34.9
11842	11845	10	Cruise	34.9	34.9
11845	11848	10	Decel.	34.9	27.9
11848	11851	10	Cruise	27.9	27.9
11851	11858	10	Accel.	27.9	43.7
11858	11861	10	Cruise	43.7	43.7
11861	11865	10	Decel.	43.7	32.1
11865	11868	10	Cruise	32.1	32.1
11868	11873	10	Decel.	32.1	12.4
11873	11880	10	Cruise	12.4	12.4
11880	11884	10	Decel.	12.4	0.0
11884	12054	10	Idle	0.0	0.0
12054	12064	10	Accel.	0.0	14.7
12064	12067	10	Cruise	14.7	14.7
12067	12072	10	Decel.	14.7	0.0

Event time start [s]	Event time end [s]	Trip [#]	Event Type	Speed at start [km/h]	Speed at end [km/h]
12072	12075	10	Idle	0.0	0.0
12075	12079	10	Accel.	0.0	13.8
12079	12082	10	Cruise	13.8	13.8
12082	12086	10	Decel.	13.8	0.0
12086	12096	10	Idle	0.0	0.0
12096	12100	10	Accel.	0.0	12.4
12100	12103	10	Cruise	12.4	12.4
12103	12106	10	Decel.	12.4	0.0
12106	12124	10	Idle	0.0	0.0
12124	12129	10	Accel.	0.0	18.7
12129	12132	10	Cruise	18.7	18.7
12132	12140	10	Decel.	18.7	0.0
12140	12173	10	Idle	0.0	0.0
12173	12178	10	Accel.	0.0	18.4
12178	12181	10	Cruise	18.4	18.4
12181	12187	10	Decel.	18.4	0.0
12187	12188	10	Idle	0.0	0.0
12188	12197	10	Accel.	0.0	41.2
12197	12198	10	Cruise	41.2	41.2
12198	12202	10	Decel.	41.2	30.4
12202	12208	10	Cruise	30.4	30.4
12208	12213	10	Decel.	30.4	14.8
12213	12216	10	Cruise	14.8	14.8
12216	12231	10	Accel.	14.8	50.5
12231	12267	10	Cruise	50.5	50.5
12267	12272	10	Decel.	50.5	30.8
12272	12276	10	Cruise	30.8	30.8
12276	12284	10	Decel.	30.8	0.0
12284	12328	10	Idle	0.0	0.0
12328	12333	10	Accel.	0.0	12.4
12333	12336	10	Cruise	12.4	12.4
12336	12340	10	Decel.	12.4	0.0
12340	12356	10	Idle	0.0	0.0
12356	12361	10	Accel.	0.0	14.7
12361	12364	10	Cruise	14.7	14.7
12364	12368	10	Decel.	14.7	0.0
12368	12371	10	Idle	0.0	0.0
12371	12376	10	Accel.	0.0	18.7
12376	12461	10	Cruise	18.7	18.7
12461	12469	10	Decel.	18.7	0.0
12469	12478	10	Idle	0.0	0.0
12478	12484	10	Accel.	0.0	18.4
12484	12487	10	Cruise	18.4	18.4

Event time start [s]	Event time end [s]	Trip [#]	Event Type	Speed at start [km/h]	Speed at end [km/h]
12487	12493	10	Decel.	18.4	0.0
12493	12503	10	Idle	0.0	0.0
12503	12507	10	Accel.	0.0	13.8
12507	12510	10	Cruise	13.8	13.8
12510	12514	10	Decel.	13.8	0.0
12514	12517	10	Idle	0.0	0.0
12517	12521	10	Accel.	0.0	12.4
12521	12524	10	Cruise	12.4	12.4
12524	12528	10	Decel.	12.4	0.0
12528	12544	10	Idle	0.0	0.0
12544	12549	10	Accel.	0.0	14.7
12549	12552	10	Cruise	14.7	14.7
12552	12556	10	Decel.	14.7	0.0
12556	12559	10	Idle	0.0	0.0
12559	12602	10	Accel.	0.0	105.0
12602	12614	10	Cruise	105.0	105.0
12614	12617	10	Decel.	105.0	95.4
12617	12622	10	Cruise	95.4	95.4
12622	12626	10	Decel.	95.4	82.4
12626	12629	10	Cruise	82.4	82.4
12629	12639	10	Accel.	82.4	97.4
12639	12642	10	Cruise	97.4	97.4
12642	12646	10	Decel.	97.4	82.7
12646	12651	10	Cruise	82.7	82.7
12651	12654	10	Decel.	82.7	74.5
12654	12658	10	Cruise	74.5	74.5
12658	12668	10	Decel.	74.5	38.7
12668	12671	10	Cruise	38.7	38.7
12671	12679	10	Accel.	38.7	64.0
12679	12695	10	Cruise	64.0	64.0
12695	12702	10	Decel.	64.0	25.9
12702	12705	10	Cruise	25.9	25.9
12705	12711	10	Accel.	25.9	47.8
12711	12714	10	Cruise	47.8	47.8
12714	12718	10	Decel.	47.8	36.0
12718	12721	10	Cruise	36.0	36.0
12721	12728	10	Accel.	36.0	60.3
12728	12790	10	Cruise	60.3	60.3
12790	12796	10	Decel.	60.3	36.4
12796	12799	10	Cruise	36.4	36.4
12799	12806	10	Accel.	36.4	49.0
12806	12854	10	Cruise	49.0	49.0
12854	12858	10	Decel.	49.0	37.0

Event time start [s]	Event time end [s]	Trip [#]	Event Type	Speed at start [km/h]	Speed at end [km/h]
12858	12861	10	Cruise	37.0	37.0
12861	12877	10	Accel.	37.0	61.0
12877	12926	10	Cruise	61.0	61.0
12926	12932	10	Decel.	61.0	28.0
12932	12938	10	Cruise	28.0	28.0
12938	12944	10	Accel.	28.0	43.2
12944	12959	10	Cruise	43.2	43.2
12959	12965	10	Decel.	43.2	25.0
12965	12968	10	Cruise	25.0	25.0
12968	12974	10	Accel.	25.0	46.7
12974	12977	10	Cruise	46.7	46.7
12977	12980	10	Decel.	46.7	37.9
12980	12983	10	Cruise	37.9	37.9
12983	12997	10	Accel.	37.9	54.9
12997	13053	10	Cruise	54.9	54.9
13053	13060	10	Decel.	54.9	22.4
13060	13063	10	Cruise	22.4	22.4
13063	13067	10	Accel.	22.4	26.2
13067	13072	10	Cruise	26.2	26.2
13072	13075	10	Decel.	26.2	18.6
13075	13078	10	Cruise	18.6	18.6
13078	13080	10	Accel.	18.6	20.1
13080	13084	10	Cruise	20.1	20.1
13084	13090	10	Decel.	20.1	7.0
13090	13093	10	Cruise	7.0	7.0
13093	13097	10	Decel.	7.0	0.0
13097	13100	10	Idle	0.0	0.0
13100	13112	10	Accel.	0.0	28.0
13112	13175	10	Cruise	28.0	28.0
13175	13179	10	Decel.	28.0	16.3
13179	13182	10	Cruise	16.3	16.3
13182	13185	10	Accel.	16.3	18.6
13185	13188	10	Cruise	18.6	18.6
13188	13192	10	Decel.	18.6	7.6
13192	13195	10	Cruise	7.6	7.6
13195	13207	10	Accel.	7.6	28.7
13207	13273	10	Cruise	28.7	28.7
13273	13278	10	Decel.	28.7	14.6
13278	13281	10	Cruise	14.6	14.6
13281	13286	10	Accel.	14.6	22.9
13286	13290	10	Cruise	22.9	22.9
13290	13294	10	Decel.	22.9	12.0
13294	13297	10	Cruise	12.0	12.0

Event time start [s]	Event time end [s]	Trip [#]	Event Type	Speed at start [km/h]	Speed at end [km/h]
13297	13314	10	Accel.	12.0	46.0
13314	13334	10	Cruise	46.0	46.0
13334	13344	10	Decel.	46.0	0.0
13344	13347	10	Idle	0.0	0.0
13347	13364	10	Accel.	0.0	46.2
13364	13379	10	Cruise	46.2	46.2
13379	13384	10	Decel.	46.2	32.1
13384	13408	10	Cruise	32.1	32.1
13408	13412	10	Decel.	32.1	20.8
13412	13442	10	Cruise	20.8	20.8
13442	13445	10	Decel.	20.8	12.4
13445	13448	10	Cruise	12.4	12.4
13448	13460	10	Accel.	12.4	42.5
13460	13482	10	Cruise	42.5	42.5
13482	13488	10	Decel.	42.5	17.8
13488	13491	10	Cruise	17.8	17.8
13491	13495	10	Accel.	17.8	22.7
13495	13498	10	Cruise	22.7	22.7
13498	13506	10	Decel.	22.7	0.0
13506	13509	10	Idle	0.0	0.0
13509	13518	10	Accel.	0.0	25.0
13518	13521	10	Cruise	25.0	25.0
13521	13524	10	Decel.	25.0	17.2
13524	13527	10	Cruise	17.2	17.2
13527	13532	10	Accel.	17.2	30.9
13532	13535	10	Cruise	30.9	30.9
13535	13539	10	Decel.	30.9	16.7
13539	13542	10	Cruise	16.7	16.7
13542	13548	10	Accel.	16.7	43.0
13548	13578	10	Cruise	43.0	43.0
13578	13583	10	Decel.	43.0	29.8
13583	13586	10	Cruise	29.8	29.8
13586	13598	10	Accel.	29.8	58.8
13598	13633	10	Cruise	58.8	58.8
13633	13636	10	Decel.	58.8	48.7
13636	13639	10	Cruise	48.7	48.7
13639	13645	10	Decel.	48.7	23.8
13645	13648	10	Cruise	23.8	23.8
13648	13654	10	Accel.	23.8	44.3
13654	13676	10	Cruise	44.3	44.3
13676	13681	10	Decel.	44.3	30.3
13681	13684	10	Cruise	30.3	30.3
13684	13689	10	Accel.	30.3	41.4

Event time start [s]	Event time end [s]	Trip [#]	Event Type	Speed at start [km/h]	Speed at end [km/h]
13689	13716	10	Cruise	41.4	41.4
13716	13720	10	Decel.	41.4	28.4
13720	13723	10	Cruise	28.4	28.4
13723	13730	10	Accel.	28.4	51.4
13730	13739	10	Cruise	51.4	51.4
13739	13745	10	Decel.	51.4	32.0
13745	13748	10	Cruise	32.0	32.0
13748	13754	10	Decel.	32.0	10.0
13754	13760	10	Cruise	10.0	10.0
13760	13765	10	Decel.	10.0	0.0
13765	13768	10	Idle	0.0	0.0
13768	13772	10	Accel.	0.0	16.3
13772	13775	10	Cruise	16.3	16.3
13775	13780	10	Decel.	16.3	0.0
13780	13783	10	Idle	0.0	0.0
13783	13796	10	Accel.	0.0	45.8
13796	13817	10	Cruise	45.8	45.8
13817	13822	10	Decel.	45.8	28.6
13822	13825	10	Cruise	28.6	28.6
13825	13833	10	Accel.	28.6	40.9
13833	13836	10	Cruise	40.9	40.9
13836	13841	10	Decel.	40.9	25.4
13841	13844	10	Cruise	25.4	25.4
13844	13850	10	Accel.	25.4	41.1
13850	13853	10	Cruise	41.1	41.1
13853	13856	10	Decel.	41.1	30.7
13856	13862	10	Cruise	30.7	30.7
13862	13865	10	Decel.	30.7	22.1
13865	13868	10	Cruise	22.1	22.1
13868	13873	10	Accel.	22.1	28.2
13873	13878	10	Cruise	28.2	28.2
13878	13881	10	Decel.	28.2	21.2
13881	13947	10	Cruise	21.2	21.2
13947	13953	10	Accel.	21.2	37.6
13953	13956	10	Cruise	37.6	37.6
13956	13959	10	Decel.	37.6	29.8
13959	13962	10	Cruise	29.8	29.8
13962	13972	10	Accel.	29.8	42.8
13972	13975	10	Cruise	42.8	42.8
13975	13978	10	Decel.	42.8	34.5
13978	13981	10	Cruise	34.5	34.5
13981	13988	10	Accel.	34.5	50.6
13988	13994	10	Cruise	50.6	50.6

Event time start [s]	Event time end [s]	Trip [#]	Event Type	Speed at start [km/h]	Speed at end [km/h]
13994	14001	10	Decel.	50.6	21.2
14001	14004	10	Cruise	21.2	21.2
14004	14016	10	Accel.	21.2	49.9
14016	14019	10	Cruise	49.9	49.9
14019	14025	10	Decel.	49.9	25.2
14025	14028	10	Cruise	25.2	25.2
14028	14031	10	Accel.	25.2	38.8
14031	14034	10	Cruise	38.8	38.8
14034	14040	10	Decel.	38.8	19.6
14040	14113	10	Cruise	19.6	19.6
14113	14118	10	Accel.	19.6	30.8
14118	14121	10	Cruise	30.8	30.8
14121	14127	10	Decel.	30.8	10.2
14127	14130	10	Cruise	10.2	10.2
14130	14135	10	Accel.	10.2	26.3
14135	14138	10	Cruise	26.3	26.3
14138	14142	10	Decel.	26.3	16.5
14142	14145	10	Cruise	16.5	16.5
14145	14147	10	Accel.	16.5	19.0
14147	14150	10	Cruise	19.0	19.0
14150	14154	10	Decel.	19.0	7.6
14154	14157	10	Cruise	7.6	7.6
14157	14161	10	Decel.	7.6	0.0
14161	14164	10	Idle	0.0	0.0
14164	14172	10	Accel.	0.0	32.2
14172	14175	10	Cruise	32.2	32.2
14175	14180	10	Decel.	32.2	13.6
14180	14189	10	Cruise	13.6	13.6
14189	14195	10	Decel.	13.6	0.0
14195	14257	10	Idle	0.0	0.0
14257	14263	10	Accel.	0.0	24.9
14263	14266	10	Cruise	24.9	24.9
14266	14270	10	Decel.	24.9	10.9
14270	14277	10	Cruise	10.9	10.9
14277	14281	10	Decel.	10.9	0.0
14281	14284	10	Idle	0.0	0.0
14284	14287	10	Accel.	0.0	11.0
14287	14290	10	Cruise	11.0	11.0
14290	14294	10	Decel.	11.0	0.0
14294	14296	10	Idle	0.0	0.0
14296	14310	10	Accel.	0.0	64.9
14310	14325	10	Cruise	64.9	64.9
14325	14333	10	Decel.	64.9	25.5

Event time start [s]	Event time end [s]	Trip [#]	Event Type	Speed at start [km/h]	Speed at end [km/h]
14333	14336	10	Cruise	25.5	25.5
14336	14360	10	Accel.	25.5	112.0
14360	14992	10	Cruise	112.0	112.0
14992	15001	10	Decel.	112.0	56.1
15001	15004	10	Cruise	56.1	56.1
15004	15010	10	Accel.	56.1	68.2
15010	15013	10	Cruise	68.2	68.2
15013	15021	10	Decel.	68.2	12.0
15021	15024	10	Cruise	12.0	12.0
15024	15045	10	Accel.	12.0	80.9
15045	15048	10	Cruise	80.9	80.9
15048	15057	10	Decel.	80.9	35.3
15057	15060	10	Cruise	35.3	35.3
15060	15073	10	Accel.	35.3	73.4
15073	15076	10	Cruise	73.4	73.4
15076	15083	10	Decel.	73.4	39.3
15083	15086	10	Cruise	39.3	39.3
15086	15098	10	Decel.	39.3	0.0
15098	15102	10	Idle	0.0	0.0
15102	15148	10	Accel.	0.0	132.5
15148	15457	10	Cruise	132.5	132.5
15457	15472	10	Decel.	132.5	34.0
15472	15475	10	Cruise	34.0	34.0
15475	15479	10	Accel.	34.0	41.6
15479	15482	10	Cruise	41.6	41.6
15482	15491	10	Decel.	41.6	0.0
15491	15542	10	Idle	0.0	0.0
15542	15557	10	Accel.	0.0	33.1
15557	15584	10	Cruise	33.1	33.1
15584	15590	10	Decel.	33.1	6.3
15590	15593	10	Cruise	6.3	6.3
15593	15605	10	Accel.	6.3	37.6
15605	15625	10	Cruise	37.6	37.6
15625	15636	10	Decel.	37.6	0.0
15636	15639	10	Idle	0.0	0.0
15639	15654	10	Accel.	0.0	52.0
15654	15664	10	Cruise	52.0	52.0
15664	15675	10	Decel.	52.0	0.0
15675	15676	10	Idle	0.0	0.0
15676	15690	10	Accel.	0.0	50.6
15690	15717	10	Cruise	50.6	50.6
15717	15724	10	Decel.	50.6	22.9
15724	15727	10	Cruise	22.9	22.9



Event time start [s]	Event time end [s]	Trip [#]	Event Type	Speed at start [km/h]	Speed at end [km/h]
15727	15738	10	Accel.	22.9	47.7
15738	15742	10	Cruise	47.7	47.7
15742	15749	10	Decel.	47.7	23.4
15749	15752	10	Cruise	23.4	23.4
15752	15769	10	Accel.	23.4	45.9
15769	15791	10	Cruise	45.9	45.9
15791	15797	10	Decel.	45.9	23.6
15797	15802	10	Cruise	23.6	23.6
15802	15808	10	Accel.	23.6	37.6
15808	15815	10	Cruise	37.6	37.6
15815	15822	10	Decel.	37.6	0.0
15822	15826	10	Idle	0.0	0.0

## Annex B

## WLTP-Brake Cycle Brake Events

Trip	Brake Event #	Start time [s]	End time [s]	Event duration [s]	Initial Speed Setpoint [km/h]	Final Speed Setpoint [km/h]	Deceleration Rate [m/s <sup>2</sup> ]	Event Distance [m]	Specific KE (Decel only) [J/kg]
1	1	18	24	6.0	20.7	0.0	0.958	17.24	16.52
1	2	58	65	7.0	23.1	5.6	0.695	27.88	19.39
1	3	85	89	4.0	15.4	4.4	0.760	11.01	8.37
1	4	103	109	6.0	25.7	7.2	0.857	27.47	23.55
1	5	129	132	3.0	24.8	16.7	0.748	17.28	12.92
1	6	140	149	9.0	18.7	0.0	0.577	23.36	13.48
1	7	177	183	6.0	32.5	0.0	1.506	27.11	40.83
1	8	298	303	5.0	27.5	11.8	0.872	27.31	23.82
1	9	314	320	6.0	29.4	9.7	0.915	32.59	29.83
1	10	341	347	6.0	31.9	9.5	1.037	34.47	35.74
1	11	361	366	5.0	14.7	0.0	0.814	10.18	8.29
1	12	384	388	4.0	59.5	47.6	0.820	59.50	48.79
1	13	402	406	4.0	47.6	36.2	0.793	46.59	36.95
1	14	486	490	4.0	38.2	25.5	0.881	35.42	31.19
1	15	493	496	3.0	25.5	18.4	0.659	18.32	12.08
1	16	499	505	6.0	18.4	0.0	0.853	15.35	13.09
1	17	543	552	9.0	42.3	0.0	1.306	52.88	69.03
1	18	566	576	10.0	42.1	0.0	1.170	58.48	68.38
1	19	592	595	3.0	31.3	12.5	1.746	18.25	31.87
1	20	600	605	5.0	12.5	0.0	0.693	8.66	6.00
1	21	647	657	10.0	45.3	0.0	1.258	62.88	79.07
1	22	673	683	10.0	45.5	0.0	1.265	63.25	80.01
1	23	726	733	7.0	40.7	12.8	1.109	52.03	57.70
1	24	747	751	4.0	59.6	46.7	0.893	59.04	52.72
1	25	768	777	9.0	48.6	0.0	1.500	60.77	91.16
1	26	941	945	4.0	23.7	9.8	0.969	18.60	18.03
1	27	974	983	9.0	37.5	0.0	1.157	46.86	54.22
1	28	996	1005	9.0	37.7	0.0	1.164	47.14	54.86
1	29	1016	1021	5.0	18.6	0.0	1.036	12.95	13.40
2	30	1122	1126	4.0	13.8	0.0	0.960	7.68	7.38
2	31	1147	1151	4.0	34.2	18.9	1.059	29.52	31.26
2	32	1174	1178	4.0	32.9	23.3	0.664	31.19	20.71
2	33	1188	1191	3.0	25.6	18.5	0.653	18.37	11.99
2	34	1209	1217	8.0	38.7	0.0	1.343	42.98	57.72
2	35	1253	1256	3.0	48.4	40.6	0.728	37.09	26.99
2	36	1282	1286	4.0	42.4	30.3	0.840	40.41	33.96
2	37	1290	1295	5.0	30.3	13.7	0.921	30.60	28.18
2	38	1319	1325	6.0	40.0	20.0	0.929	49.98	46.44

Trip	Brake Event #	Start time [s]	End time [s]	Event duration [s]	Initial Speed Setpoint [km/h]	Final Speed Setpoint [km/h]	Deceleration Rate [m/s <sup>2</sup> ]	Event Distance [m]	Specific KE (Decel only) [J/kg]
2	39	1334	1338	4.0	29.7	18.9	0.747	26.98	20.16
2	40	1448	1451	3.0	24.5	17.5	0.643	17.51	11.25
2	41	1482	1491	9.0	42.0	0.0	1.296	52.49	68.02
2	42	1515	1519	4.0	22.0	11.8	0.704	18.77	13.21
2	43	1539	1547	8.0	32.4	6.1	0.915	42.81	39.17
2	44	1597	1605	8.0	34.8	0.0	1.208	38.66	46.70
2	45	1662	1675	13.0	76.1	0.0	1.626	137.41	223.43
2	46	1689	1694	5.0	22.8	0.0	1.269	15.86	20.13
2	47	1753	1757	4.0	41.6	27.2	0.995	38.23	38.04
2	48	1804	1807	3.0	47.9	35.2	1.177	34.59	40.70
2	49	1823	1828	5.0	35.2	20.1	0.836	38.37	32.08
2	50	1870	1873	3.0	59.2	49.5	0.904	45.29	40.92
2	51	1895	1898	3.0	72.9	62.0	1.010	56.23	56.80
2	52	1907	1910	3.0	66.4	57.4	0.828	51.58	42.69
2	53	1918	1921	3.0	60.0	52.1	0.727	46.71	33.95
2	54	1951	1954	3.0	79.7	72.1	0.697	63.26	44.10
2	55	1972	1978	6.0	74.0	52.4	0.999	105.35	105.20
2	56	2062	2074	12.0	52.4	0.0	1.213	87.37	106.01
2	57	2123	2133	10.0	60.3	0.0	1.676	83.80	140.42
2	58	2187	2195	8.0	62.9	0.0	2.183	69.86	152.49
2	59	2218	2229	11.0	60.1	15.2	1.133	115.11	130.45
2	60	2250	2261	11.0	53.3	0.0	1.345	81.39	109.48
2	61	2520	2526	6.0	20.7	0.0	0.958	17.24	16.52
2	62	2560	2567	7.0	23.1	5.6	0.695	27.88	19.39
2	63	2587	2591	4.0	15.4	4.4	0.760	11.01	8.37
2	64	2605	2611	6.0	25.7	7.2	0.857	27.47	23.55
2	65	2631	2634	3.0	24.8	16.7	0.748	17.28	12.92
2	66	2642	2650	8.0	18.7	0.0	0.649	20.77	13.48
2	67	2672	2677	5.0	46.6	9.4	2.070	38.89	80.50
2	68	2698	2701	3.0	52.0	41.5	0.970	38.99	37.83
2	69	2714	2719	5.0	49.9	34.0	0.884	58.20	51.44
2	70	2738	2745	7.0	49.0	23.8	0.998	70.76	70.59
2	71	2759	2767	8.0	41.6	0.0	1.446	46.26	66.86
3	72	2897	2903	6.0	32.1	5.5	1.232	31.37	38.63
3	73	2946	2949	3.0	50.5	42.8	0.714	38.91	27.77
3	74	2958	2963	5.0	45.0	29.8	0.843	51.91	43.77
3	75	2966	2971	5.0	29.8	0.0	1.655	20.68	34.21
3	76	3006	3011	5.0	49.2	33.1	0.893	57.16	51.06
3	77	3032	3036	4.0	56.2	44.0	0.841	55.66	46.81
3	78	3053	3056	3.0	59.0	51.2	0.722	45.95	33.19
3	79	3078	3081	3.0	55.0	47.5	0.692	42.72	29.55
3	80	3096	3101	5.0	59.5	39.9	1.085	69.02	74.89
3	81	3159	3165	6.0	39.9	14.2	1.189	45.14	53.69

Trip	Brake Event #	Start time [s]	End time [s]	Event duration [s]	Initial Speed Setpoint [km/h]	Final Speed Setpoint [km/h]	Deceleration Rate [m/s <sup>2</sup> ]	Event Distance [m]	Specific KE (Decel only) [J/kg]
3	82	3195	3201	6.0	58.3	34.8	1.086	77.60	84.28
3	83	3268	3271	3.0	39.5	30.0	0.882	28.98	25.57
3	84	3308	3311	3.0	56.2	46.0	0.943	42.56	40.12
3	85	3418	3422	4.0	54.4	40.4	0.974	52.67	51.32
3	86	3441	3445	4.0	53.5	40.8	0.885	52.37	46.33
3	87	3480	3483	3.0	40.8	32.0	0.815	30.30	24.69
3	88	3492	3495	3.0	34.7	26.4	0.776	25.45	19.75
3	89	3557	3561	4.0	50.6	37.6	0.900	48.97	44.07
3	90	3621	3626	5.0	37.6	22.4	0.842	41.68	35.10
3	91	3647	3651	4.0	36.8	22.9	0.964	33.20	32.00
3	92	3684	3688	4.0	55.3	39.5	1.099	52.67	57.90
3	93	3692	3698	6.0	39.5	15.5	1.111	45.82	50.91
3	94	3729	3732	3.0	44.3	36.6	0.710	33.68	23.92
3	95	3773	3778	5.0	36.6	20.8	0.879	39.82	35.00
3	96	3849	3852	3.0	32.0	24.8	0.662	23.67	15.67
3	97	3879	3883	4.0	51.6	39.3	0.858	50.49	43.34
3	98	3895	3898	3.0	39.3	32.4	0.634	29.86	18.94
3	99	3939	3946	7.0	32.4	0.0	1.286	31.51	40.53
4	100	4001	4005	4.0	75.8	63.9	0.832	77.61	64.57
4	101	4089	4093	4.0	72.4	58.7	0.958	72.83	69.74
4	102	4118	4122	4.0	65.9	53.7	0.849	66.48	56.46
4	103	4147	4157	10.0	54.9	0.0	1.524	76.18	116.07
4	104	4551	4566	15.0	90.6	0.0	1.677	188.65	316.33
4	105	4668	4683	15.0	95.6	25.5	1.299	252.30	327.79
4	106	5004	5019	15.0	98.4	0.0	1.822	204.95	373.33
4	107	5071	5076	5.0	82.8	69.4	0.748	105.67	79.02
4	108	5135	5149	14.0	69.4	10.1	1.176	154.45	181.63
4	109	5190	5193	3.0	69.0	61.7	0.673	54.48	36.67
4	110	5297	5300	3.0	64.7	57.8	0.641	51.07	32.72
4	111	5314	5326	12.0	57.8	0.0	1.338	96.37	128.98
4	112	5350	5356	6.0	20.7	0.0	0.958	17.24	16.52
4	113	5390	5397	7.0	23.1	5.6	0.695	27.88	19.39
4	114	5417	5421	4.0	15.4	4.4	0.760	11.01	8.37
4	115	5435	5441	6.0	25.7	7.2	0.857	27.47	23.55
4	116	5461	5464	3.0	24.8	16.7	0.748	17.28	12.92
4	117	5472	5480	8.0	18.7	0.0	0.649	20.77	13.48
5	118	5514	5524	10.0	41.8	0.0	1.160	57.99	67.25
5	119	5554	5557	3.0	34.6	27.3	0.680	25.79	17.53
5	120	5571	5581	10.0	43.5	0.0	1.207	60.36	72.87
5	121	5624	5629	5.0	30.0	13.6	0.913	30.29	27.67
5	122	5647	5656	9.0	37.0	0.0	1.140	46.19	52.67
5	123	5749	5753	4.0	41.2	29.5	0.812	39.29	31.89
5	124	5789	5792	3.0	29.5	18.0	1.066	19.80	21.10

Trip	Brake Event #	Start time [s]	End time [s]	Event duration [s]	Initial Speed Setpoint [km/h]	Final Speed Setpoint [km/h]	Deceleration Rate [m/s <sup>2</sup> ]	Event Distance [m]	Specific KE (Decel only) [J/kg]
5	125	5795	5800	5.0	18.0	0.0	1.000	12.50	12.50
5	126	5814	5817	3.0	29.5	22.1	0.677	21.50	14.55
5	127	5820	5824	4.0	22.1	8.1	0.974	16.81	16.37
5	128	5844	5849	5.0	16.9	0.0	0.939	11.74	11.03
5	129	5965	5968	3.0	14.4	3.5	1.007	7.44	7.49
5	130	6074	6078	4.0	56.4	41.2	1.061	54.21	57.52
5	131	6081	6088	7.0	41.2	13.9	1.083	53.47	57.93
5	132	6175	6180	5.0	56.4	41.3	0.835	67.83	56.64
5	133	6208	6213	5.0	58.0	39.6	1.020	67.74	69.09
5	134	6248	6252	4.0	39.6	22.3	1.199	34.40	41.23
5	135	6320	6330	10.0	26.7	0.0	0.741	37.06	27.46
5	136	6872	6876	4.0	105.2	90.4	1.028	108.66	111.67
5	137	6898	6901	3.0	102.2	91.6	0.977	80.77	78.89
5	138	6930	6932	2.0	94.6	87.2	1.039	50.50	52.46
5	139	6953	6957	4.0	87.2	72.3	1.031	88.60	91.36
5	140	6977	6981	4.0	84.8	73.8	0.766	88.11	67.49
5	141	6999	7005	6.0	87.8	69.0	0.871	130.61	113.79
5	142	7069	7074	5.0	69.0	50.2	1.039	82.77	86.04
5	143	7114	7117	3.0	83.5	71.3	1.128	64.49	72.72
5	144	7177	7182	5.0	71.3	53.5	0.991	86.64	85.81
5	145	7201	7205	4.0	80.0	66.0	0.974	81.14	78.99
5	146	7346	7349	3.0	66.0	56.7	0.859	51.14	43.94
5	147	7381	7388	7.0	83.9	42.5	1.642	122.89	201.73
5	148	7442	7455	13.0	73.8	24.4	1.056	177.40	187.36
5	149	7490	7496	6.0	24.4	0.0	1.130	20.34	22.99
5	150	7518	7522	4.0	22.9	13.5	0.651	20.19	13.15
5	151	7534	7537	3.0	23.0	15.4	0.702	16.02	11.24
5	152	7548	7551	3.0	19.0	12.2	0.631	12.99	8.19
5	153	7561	7567	6.0	18.8	0.0	0.869	15.65	13.61
5	154	7704	7709	5.0	37.9	24.4	0.750	43.29	32.47
5	155	7748	7752	4.0	24.4	14.9	0.661	21.85	14.44
5	156	7769	7774	5.0	45.3	25.9	1.075	49.44	53.15
5	157	7795	7800	5.0	40.6	25.4	0.849	45.84	38.91
5	158	7817	7822	5.0	37.2	20.8	0.913	40.30	36.78
5	159	7883	7889	6.0	26.3	0.0	1.215	21.88	26.58
5	160	7907	7913	6.0	53.4	28.2	1.167	67.98	79.34
5	161	7941	7947	6.0	42.6	19.0	1.093	51.27	56.01
5	162	7973	7979	6.0	57.1	31.8	1.170	74.11	86.70
5	163	8064	8069	5.0	50.0	24.4	1.422	51.67	73.48
5	164	8081	8088	7.0	58.2	29.9	1.123	85.65	96.14
5	165	8120	8123	3.0	29.9	21.2	0.803	21.31	17.10
5	166	8168	8174	6.0	32.6	0.0	1.507	27.13	40.88
6	167	8413	8418	5.0	21.2	9.5	0.653	21.29	13.91

Trip	Brake Event #	Start time [s]	End time [s]	Event duration [s]	Initial Speed Setpoint [km/h]	Final Speed Setpoint [km/h]	Deceleration Rate [m/s <sup>2</sup> ]	Event Distance [m]	Specific KE (Decel only) [J/kg]
6	168	8421	8425	4.0	9.5	0.0	0.656	5.25	3.45
7	169	8552	8560	8.0	35.1	5.5	1.028	45.06	46.32
7	170	8609	8614	5.0	16.5	0.0	0.915	11.44	10.47
7	171	9081	9089	8.0	96.9	73.3	0.821	189.13	155.30
7	172	9117	9127	10.0	73.3	20.1	1.477	129.73	191.56
7	173	9146	9155	9.0	62.2	6.6	1.716	86.05	147.67
7	174	9174	9187	13.0	53.2	0.0	1.137	96.11	109.31
8	175	9264	9279	15.0	83.6	0.0	1.549	174.24	269.83
8	176	9375	9382	7.0	23.9	0.0	0.946	23.19	21.95
8	177	9427	9439	12.0	65.3	0.0	1.512	108.86	164.56
8	178	9489	9493	4.0	40.5	29.3	0.783	38.78	30.38
8	179	9812	9815	3.0	63.0	52.2	1.006	48.01	48.28
8	180	9845	9848	3.0	52.2	44.6	0.701	40.33	28.27
8	181	9864	9869	5.0	59.2	45.2	0.777	72.49	56.30
8	182	9888	9898	10.0	53.9	0.0	1.497	74.85	112.04
9	183	10036	10041	5.0	19.1	6.4	0.704	17.66	12.43
9	184	10049	10054	5.0	10.5	0.0	0.582	7.27	4.23
9	185	10273	10280	7.0	29.6	0.0	1.175	28.79	33.83
9	186	10453	10458	5.0	24.3	4.5	1.101	19.98	21.99
9	187	10475	10479	4.0	27.8	17.3	0.734	25.05	18.39
9	188	10482	10486	4.0	17.3	6.5	0.747	13.20	9.86
9	189	10507	10514	7.0	26.8	0.0	1.062	26.02	27.63
10	190	10638	10647	9.0	27.5	0.0	0.849	34.38	29.18
10	191	10696	10700	4.0	39.0	29.0	0.689	37.77	26.02
10	192	10721	10725	4.0	35.1	24.5	0.740	33.12	24.49
10	193	10758	10761	3.0	41.9	34.1	0.720	31.66	22.81
10	194	10792	10797	5.0	39.4	24.9	0.807	44.68	36.04
10	195	10811	10822	11.0	36.4	0.0	0.920	55.67	51.23
10	196	10868	10879	11.0	55.7	0.0	1.407	85.10	119.69
10	197	11088	11101	13.0	56.2	0.0	1.201	101.50	121.90
10	198	11117	11126	9.0	43.6	0.0	1.347	54.55	73.47
10	199	11245	11249	4.0	11.2	4.1	0.494	8.54	4.22
10	200	11261	11265	4.0	15.0	6.2	0.611	11.80	7.21
10	201	11276	11281	5.0	10.1	0.0	0.561	7.01	3.94
10	202	11313	11316	3.0	31.3	23.8	0.694	22.92	15.91
10	203	11348	11351	3.0	23.8	16.9	0.636	16.93	10.77
10	204	11354	11361	7.0	16.9	0.0	0.670	16.41	10.99
10	205	11512	11519	7.0	40.0	10.6	1.166	49.23	57.37
10	206	11541	11545	4.0	15.6	6.3	0.651	12.16	7.92
10	207	11557	11560	3.0	15.6	8.8	0.637	10.16	6.47
10	208	11574	11579	5.0	13.1	0.0	0.729	9.12	6.65
10	209	11659	11662	3.0	23.1	15.0	0.753	15.89	11.96
10	210	11669	11671	2.0	18.1	13.6	0.625	8.82	5.51

Trip	Brake Event #	Start time [s]	End time [s]	Event duration [s]	Initial Speed Setpoint [km/h]	Final Speed Setpoint [km/h]	Deceleration Rate [m/s <sup>2</sup> ]	Event Distance [m]	Specific KE (Decel only) [J/kg]
10	211	11684	11687	3.0	19.4	11.5	0.730	12.87	9.39
10	212	11690	11694	4.0	11.5	0.0	0.799	6.39	5.10
10	213	11845	11848	3.0	34.9	27.9	0.652	26.18	17.06
10	214	11861	11865	4.0	43.7	32.1	0.802	42.12	33.78
10	215	11868	11873	5.0	32.1	12.4	1.097	30.91	33.91
10	216	11880	11884	4.0	12.4	0.0	0.860	6.88	5.91
10	217	12067	12072	5.0	14.7	0.0	0.814	10.18	8.29
10	218	12082	12086	4.0	13.8	0.0	0.960	7.68	7.38
10	219	12103	12106	3.0	12.4	0.0	1.145	5.15	5.89
10	220	12132	12140	8.0	18.7	0.0	0.649	20.77	13.48
10	221	12181	12187	6.0	18.4	0.0	0.853	15.35	13.09
10	222	12198	12202	4.0	41.2	30.4	0.748	39.74	29.72
10	223	12208	12213	5.0	30.4	14.8	0.863	31.40	27.11
10	224	12267	12272	5.0	50.5	30.8	1.092	56.43	61.63
10	225	12276	12284	8.0	30.8	0.0	1.069	34.22	36.60
10	226	12336	12340	4.0	12.4	0.0	0.860	6.88	5.91
10	227	12364	12368	4.0	14.7	0.0	1.018	8.14	8.29
10	228	12461	12469	8.0	18.7	0.0	0.649	20.77	13.48
10	229	12487	12493	6.0	18.4	0.0	0.853	15.35	13.09
10	230	12510	12514	4.0	13.8	0.0	0.960	7.68	7.38
10	231	12524	12528	4.0	12.4	0.0	0.860	6.88	5.91
10	232	12552	12556	4.0	14.7	0.0	1.018	8.14	8.29
10	233	12614	12617	3.0	105.0	95.4	0.888	83.49	74.13
10	234	12622	12626	4.0	95.4	82.4	0.901	98.78	89.04
10	235	12642	12646	4.0	97.4	82.7	1.025	100.07	102.57
10	236	12651	12654	3.0	82.7	74.5	0.756	65.50	49.49
10	237	12658	12668	10.0	74.5	38.7	0.994	157.30	156.37
10	238	12695	12702	7.0	64.0	25.9	1.512	87.35	132.06
10	239	12714	12718	4.0	47.8	36.0	0.822	46.56	38.28
10	240	12790	12796	6.0	60.3	36.4	1.108	80.57	89.29
10	241	12854	12858	4.0	49.0	37.0	0.829	47.77	39.58
10	242	12926	12932	6.0	61.0	28.0	1.529	74.17	113.38
10	243	12959	12965	6.0	43.2	25.0	0.843	56.75	47.82
10	244	12977	12980	3.0	46.7	37.9	0.815	35.24	28.71
10	245	13053	13060	7.0	54.9	22.4	1.289	75.09	96.75
10	246	13072	13075	3.0	26.2	18.6	0.704	18.67	13.14
10	247	13084	13090	6.0	20.1	7.0	0.603	22.57	13.60
10	248	13093	13097	4.0	7.0	0.0	0.488	3.91	1.91
10	249	13175	13179	4.0	28.0	16.3	0.808	24.62	19.88
10	250	13188	13192	4.0	18.6	7.6	0.761	14.55	11.07
10	251	13273	13278	5.0	28.7	14.6	0.783	30.06	23.54
10	252	13290	13294	4.0	22.9	12.0	0.760	19.40	14.75
10	253	13334	13344	10.0	46.0	0.0	1.279	63.95	81.78

Trip	Brake Event #	Start time [s]	End time [s]	Event duration [s]	Initial Speed Setpoint [km/h]	Final Speed Setpoint [km/h]	Deceleration Rate [m/s <sup>2</sup> ]	Event Distance [m]	Specific KE (Decel only) [J/kg]
10	254	13379	13384	5.0	46.2	32.1	0.779	54.38	42.39
10	255	13408	13412	4.0	32.1	20.8	0.791	29.38	23.24
10	256	13442	13445	3.0	20.8	12.4	0.777	13.80	10.72
10	257	13482	13488	6.0	42.5	17.8	1.146	50.21	57.53
10	258	13498	13506	8.0	22.7	0.0	0.787	25.19	19.83
10	259	13521	13524	3.0	25.0	17.2	0.721	17.55	12.66
10	260	13535	13539	4.0	30.9	16.7	0.983	26.43	25.97
10	261	13578	13583	5.0	43.0	29.8	0.734	50.52	37.10
10	262	13633	13636	3.0	58.8	48.7	0.942	44.80	42.18
10	263	13639	13645	6.0	48.7	23.8	1.151	60.40	69.52
10	264	13676	13681	5.0	44.3	30.3	0.775	51.77	40.12
10	265	13716	13720	4.0	41.4	28.4	0.905	38.75	35.06
10	266	13739	13745	6.0	51.4	32.0	0.898	69.57	62.48
10	267	13748	13754	6.0	32.0	10.0	1.020	35.04	35.75
10	268	13760	13765	5.0	10.0	0.0	0.556	6.94	3.86
10	269	13775	13780	5.0	16.3	0.0	0.906	11.33	10.26
10	270	13817	13822	5.0	45.8	28.6	0.955	51.70	49.37
10	271	13836	13841	5.0	40.9	25.4	0.856	46.04	39.41
10	272	13853	13856	3.0	41.1	30.7	0.956	29.91	28.58
10	273	13862	13865	3.0	30.7	22.1	0.800	22.01	17.61
10	274	13878	13881	3.0	28.2	21.2	0.646	20.55	13.28
10	275	13956	13959	3.0	37.6	29.8	0.724	28.08	20.33
10	276	13975	13978	3.0	42.8	34.5	0.761	32.20	24.51
10	277	13994	14001	7.0	50.6	21.2	1.166	69.82	81.42
10	278	14019	14025	6.0	49.9	25.2	1.145	62.60	71.64
10	279	14034	14040	6.0	38.8	19.6	0.888	48.66	43.18
10	280	14121	14127	6.0	30.8	10.2	0.954	34.14	32.58
10	281	14138	14142	4.0	26.3	16.5	0.680	23.75	16.15
10	282	14150	14154	4.0	19.0	7.6	0.794	14.78	11.74
10	283	14157	14161	4.0	7.6	0.0	0.526	4.21	2.22
10	284	14175	14180	5.0	32.2	13.6	1.036	31.83	32.97
10	285	14189	14195	6.0	13.6	0.0	0.630	11.33	7.14
10	286	14266	14270	4.0	24.9	10.9	0.977	19.90	19.44
10	287	14277	14281	4.0	10.9	0.0	0.755	6.04	4.56
10	288	14290	14294	4.0	11.0	0.0	0.766	6.13	4.69
10	289	14325	14333	8.0	64.9	25.5	1.367	100.49	137.40
10	290	14992	15001	9.0	112.0	56.1	1.724	210.12	362.31
10	291	15013	15021	8.0	68.2	12.0	1.949	89.14	173.75
10	292	15048	15057	9.0	80.9	35.3	1.407	145.18	204.23
10	293	15076	15083	7.0	73.4	39.3	1.356	109.57	148.61
10	294	15086	15098	12.0	39.3	0.0	0.909	65.44	59.47
10	295	15457	15472	15.0	132.5	34.0	1.824	346.87	632.62
10	296	15482	15491	9.0	41.6	0.0	1.283	51.98	66.70



---

<b>Trip</b>	<b>Brake Event #</b>	<b>Start time [s]</b>	<b>End time [s]</b>	<b>Event duration [s]</b>	<b>Initial Speed Setpoint [km/h]</b>	<b>Final Speed Setpoint [km/h]</b>	<b>Deceleration Rate [m/s<sup>2</sup>]</b>	<b>Event Distance [m]</b>	<b>Specific KE (Decel only) [J/kg]</b>
10	297	15584	15590	6.0	33.1	6.3	1.239	32.84	40.70
10	298	15625	15636	11.0	37.6	0.0	0.948	57.37	54.40
10	299	15664	15675	11.0	52.0	0.0	1.313	79.42	104.24
10	300	15717	15724	7.0	50.6	22.9	1.102	71.46	78.77
10	301	15742	15749	7.0	47.7	23.4	0.964	69.13	66.66
10	302	15791	15797	6.0	45.9	23.6	1.032	57.87	59.74
10	303	15815	15822	7.0	37.6	0.0	1.491	36.53	54.46

---