

**Explanatory presentation to .../GRSP/2022/25:
Section B of Justification - Harmonising UN R129
vertical head excursion limit**

Submitted by the experts from CLEPA

72nd session of GRSP, 05 – 09th December 2022

HARMONISING R129 VERTICAL HEAD EXCURSION



Overview

UN R129 Vertical head excursion	Q3		Q6		Q10
	RF CRS	FF CRS	RF CRS	FF CRS	
Current limit (mm)	840	800	840	800	840
CLEPA proposal limit (mm)	840		840		840

RF = Rear-facing; FF = Forward-facing

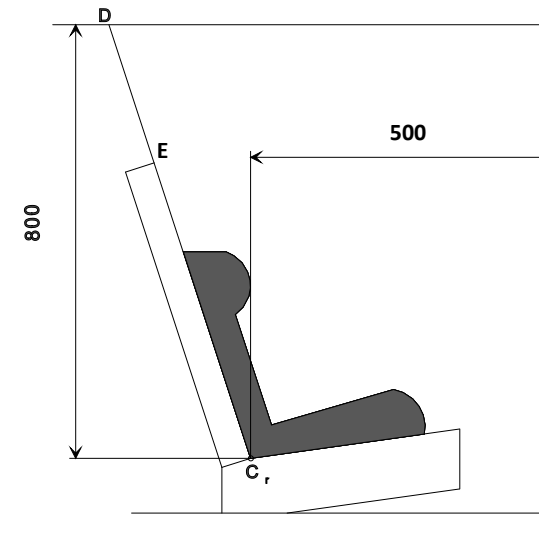
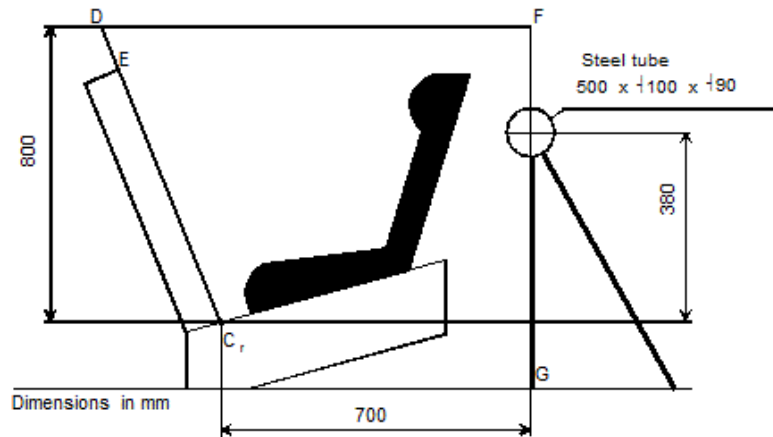

HARMONISING R129 VERTICAL HEAD EXCURSION



Space above the CR point in cars

- **Cars provide 840 mm**
 - Top 70 by sales (2019) plus 9 new models
 - All segments included:

