

## **Proposal for Supplement 3 to the 03 Series of Amendments to UN Regulation No. 100 (Electric power trained vehicles)**

### **Submitted by the expert from the International Association of the Body and Trailer Building Industry \***

The text reproduced below was prepared by the experts from International Association of the Body and Trailer Building Industry (CLCCR) and proposes amendments on the document ECE/TRANS/WP.29/GRSP/2022/14. The proposed amendments base on comments given in the 71<sup>st</sup> session of UNECE GRSP and given by the International Organization of Motor Vehicle Manufacturers (OICA). The original modifications to the current text of the UN Regulation are marked in bold characters or strikethrough for deleted characters. The revised modifications are marked in red bold characters.

## **I. Proposal**

*Paragraphs 1.1. and 1.2., amend to read:*

### **"1. Scope**

1.1. Part I: Safety requirements with respect to the electric power train of road vehicles of categories M, ~~and N~~ **and O**<sup>1</sup>, with a maximum design speed exceeding 25 km/h, equipped with electric power train<sup>2</sup>, excluding vehicles permanently connected to the grid.

Part I of this regulation does not cover;

- (a) Post-crash safety requirements of road vehicles.
- (b) High voltage components and systems which are not galvanically connected to the high voltage bus of the electric power train.

1.2. Part II: Safety requirements with respect to the Rechargeable Electrical Energy Storage System (REESS), of road vehicles of categories M, ~~and N~~ **and O** equipped with electric power train, excluding vehicles permanently connected to the grid.

Part II of this Regulation does not apply to a battery whose primary use is to supply power for starting the engine and/or lighting and/or other vehicle auxiliaries' systems."

*Paragraph 2.1., amend to read:*

---

<sup>1</sup> As defined in the Consolidated Resolution on the Construction of Vehicles (R.E.3.), document ECE/TRANS/WP.29/78/Rev.6, para. 2. – <https://unece.org/transport/standards/transport/vehicle-regulations-wp29/resolutions>

<sup>2</sup> **Contracting Parties applying this Regulation may retain specific requirements with respect to the transfer of electric energy for electrical propulsion between a towing vehicle and towed vehicle.**

## "2. Definitions

For the purpose of this Regulation the following definitions apply:

- 2.1. "Active driving possible mode" means the vehicle mode when application of pressure to the accelerator pedal (or activation of an equivalent control) or release of the brake system will cause the electric power train to move the vehicle **or in case of a vehicle of category O, the vehicle mode when coupled with a towing vehicle in active driving possible mode.**"

Paragraph 5.1.1., amend to read:

### "5.1.1. Protection against direct contact

Live parts shall comply with paragraphs 5.1.1.1. and 5.1.1.2. for protection against direct contact. Electrical protection barriers, enclosures, solid insulators and connectors shall not be able to be opened, separated, disassembled or removed without the use of tools or, for vehicles of categories N<sub>2</sub>, N<sub>3</sub>, M<sub>2</sub>, ~~and~~ M<sub>3</sub>, **O<sub>3</sub> and O<sub>4</sub>**, an operator-controlled activation/deactivation device or equivalent.

However, connectors (including the vehicle inlet) are allowed to be separated without the use of tools, if they meet one or more of the following requirements:

- (a) They comply with paragraphs 5.1.1.1. and 5.1.1.2. when separated, or
- (b) They are provided with a locking mechanism (at least two distinct actions are needed to separate the connector from its mating component). Additionally, other components, not being part of the connector, shall be removable only with the use of tools or, for vehicles of categories N<sub>2</sub>, N<sub>3</sub>, M<sub>2</sub>, ~~and~~ M<sub>3</sub>, **O<sub>3</sub> and O<sub>4</sub>**, an operator controlled activation/deactivation device or equivalent in order to be able to separate the connector, or
- (c) The voltage of the live parts becomes equal or below 60 V DC or equal or below 30 V AC (rms) within 1 s after the connector is separated.

For vehicles of categories N<sub>2</sub>, N<sub>3</sub>, M<sub>2</sub>, ~~and~~ M<sub>3</sub>, **O<sub>3</sub> and O<sub>4</sub>**, conductive connection devices not energized except during charging of the REESS are exempted from this requirement if located on the roof of the vehicle out of reach for a person standing outside of the vehicle and, for vehicles of category M<sub>2</sub> and M<sub>3</sub>, the minimum wrap around distance from the instep of the vehicle to the roof mounted charging devices is 3 m. In case of multiple steps due to an elevated floor inside the vehicle, the wrap around distance is measured from the bottom most step at entry, as illustrated in Figure 1."

Figure 1  
**Schematic to Measure Wrap-Around Distance**

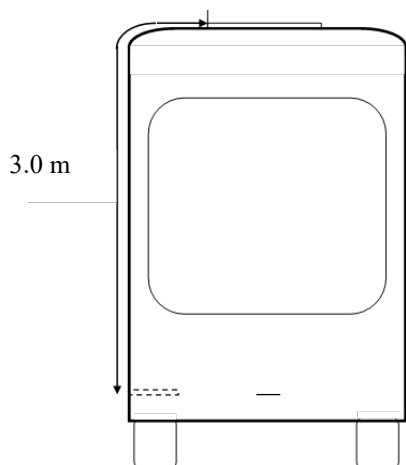

*Paragraph 5.1.1.3.*, amend to read:

"5.1.1.3. Service disconnect

For a high voltage service disconnect which can be opened, disassembled or removed without tools, or for vehicles of categories N<sub>2</sub>, N<sub>3</sub>, M<sub>2</sub>, ~~and~~ M<sub>3</sub>, **O<sub>3</sub> and O<sub>4</sub>**, an operator controlled activation/deactivation device or equivalent, protection degree IPXXB shall be satisfied when it is opened, disassembled or removed."

*Paragraph 5.1.1.4.2.*, amend to read:

"5.1.1.4.2. The symbol shall also be visible on enclosures and electrical protection barriers, which, when removed, expose live parts of high voltage circuits. This provision is optional to any connector for high voltage buses. This provision shall not apply to any of the following cases:

- (a) Where electrical protection barriers or enclosures cannot be physically accessed, opened, or removed; unless other vehicle components are removed with the use of tools;
- (b) Where electrical protection barriers or enclosures are located underneath the vehicle floor.
- (c) Electrical protection barriers or enclosures of conductive connection device for vehicles of categories N<sub>2</sub>, N<sub>3</sub>, M<sub>2</sub>, ~~and~~ M<sub>3</sub>, **O<sub>3</sub> and O<sub>4</sub>** which satisfies the conditions prescribed in paragraph 5.1.1."

*Paragraph 5.1.2.3.*, amend to read:

"5.1.2.3. In the case of ~~motor~~ vehicles which are intended to be connected to the grounded external electric power supply through the conductive connection between vehicle inlet and vehicle connector, a device to enable the galvanical connection of the electrical chassis to the earth ground for the external electric power supply shall be provided.

The device should enable connection to the earth ground before exterior voltage is applied to the vehicle and retain the connection until after the exterior voltage is removed from the vehicle.

Compliance to this requirement may be demonstrated either by using the connector specified by the vehicle manufacturer, by visual inspection or drawings.

The above requirements are only applicable for vehicles when charging from a stationary charging point, with a charging cable of finite length, through a vehicle coupler comprising a vehicle connector and a vehicle inlet."

*Paragraphs 5.2.3. and 5.2.4.* amend to read:

"5.2.3. Warning in the event of failure in REESS

The vehicle shall provide a warning to the driver when the vehicle is in active driving possible mode in the event specified in paragraphs 6.13. to 6.15.

In case of optical warning, the tell-tale shall, when illuminated, be sufficiently bright to be visible to the driver under both daylight and night-time driving conditions, when the driver has adapted to the ambient roadway light conditions.

This tell-tale shall be activated as a check of lamp function either when the propulsion system is turned to the "On" position, or when the propulsion system is in a position between "On" and "Start" that is designated by the manufacturer as a check position. This requirement does not apply to the tell-tale or text shown in a common space.

**Notwithstanding the provisions above, in the case of vehicles of category O<sub>1</sub> and O<sub>2</sub>, the vehicle shall be equipped with a communication interface to exchange a warning ~~provide an optical and/or audible warning to the driver of~~ to the towing vehicle in the event specified in paragraphs 6.13. to 6.15. This may be achieved as a wired or a wireless interface with an open standard specification. The information shared over this link is to be secured against outside interference.**

**Notwithstanding the provisions above, in case of vehicles of category O<sub>3</sub> and O<sub>4</sub>, the vehicle shall provide to the towing vehicle a signal to address an optical warning according to this paragraph and/or an audible warning (e.g. transmission via CAN-Bus according to ISO 11992-2 or by using a wired or a wireless interface with an open standard specification) in the event specified in paragraphs 6.13. to 6.15."**

5.2.4. Warning in the event of low energy content of REESS.

For pure electric vehicles (vehicles equipped with a powertrain containing exclusively electric machines as propulsion energy converters and exclusively rechargeable electric energy storage systems as propulsion energy storage systems), a warning to the driver in the event of low REESS state of charge shall be provided. Based on engineering judgment, the manufacturer shall determine the necessary level of REESS energy remaining, when the driver warning is first provided.

In case of optical warning, the tell-tale shall, when illuminated, be sufficiently bright to be visible to the driver under both daylight and night-time driving conditions, when the driver has adapted to the ambient roadway light conditions.

**This warning signal is not required for vehicles of category O."**

*Paragraphs 5.3.1. and 5.3.2. amend to read:*

"5.3.1. At least a momentary indication shall be given to the driver each time when the vehicle is first placed in "active driving possible mode" after manual activation of the propulsion system.

However, this provision is optional under conditions where an internal combustion engine provides directly or indirectly the vehicle's propulsion power upon start up **and for vehicles of category O.**

**To ensure that a vehicle of category O does not activate its driving mode independently, ~~ensure that~~ its propulsion system shall only be is-only activated if the moving towing vehicle is actively transferring forces on the trailer's coupling device or if a signal for the propulsion system is transmitted by the towing vehicle to the trailer.**

5.3.2. When leaving the vehicle, the driver shall be informed by a signal (e.g. optical or audible signal) if the vehicle is still in the active driving possible mode. Moreover, in case of vehicles of category M<sub>2</sub> and M<sub>3</sub> with a capacity of more

than 22 passengers in addition to the driver, this signal shall already be given when the drivers leave their seat.

However, this provision is optional under conditions where an internal combustion engine provides, directly or indirectly, the vehicle's propulsion power while leaving the vehicle or driver seat **and for vehicles of category O.**"

*Paragraph 5.3.3., amend to read:*

"5.3.3. If the REESS can be externally charged, vehicle movement by its own propulsion system shall be impossible as long as the vehicle connector is physically connected to the vehicle inlet.

This requirement shall be demonstrated by using the vehicle connector specified by the vehicle manufacturer.

**In the case of vehicles of category O under the scope of UN Regulation No. 100, the vehicle shall be equipped with wheel chock(s) to prevent the vehicle movement during the charging from external power supply. ~~provide an audible warning if any vehicle movement is detected, and movement shall be impeded by the use of wheel chocks.~~ A visual instruction shall be made visible by a symbol shown in Figure 3 near the vehicle inlet.**

Figure 3

**Marking of vehicles of category O under the scope of UN Regulation No. 100: ~~Use of wheel chocks~~**

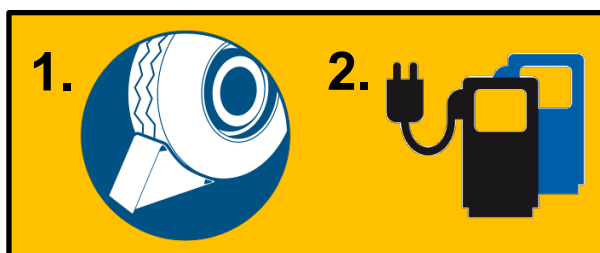

The above requirements are only applicable for vehicles when charging from a stationary charging point, with a charging cable of finite length, through a vehicle coupler comprising a vehicle connector and a vehicle inlet."

Paragraph 6.5. amend to read:

"6.5. Fire resistance

This test is required for REESS containing flammable electrolyte.

This test is not required when the REESS as installed in the vehicle, is mounted such that the lowest surface of the casing of the REESS is more than 1.5m above the ground **and or for the REESS used for a vehicle of Category O.** At the option of the manufacturer, this test may be performed where the ~~of the~~ REESS's lower surface is higher than 1.5 m above the ground. The test shall be carried out on one test sample.

**~~This test is not required when the installation of REESS is outside the loading compartment of a vehicle of category O.~~**

At the manufacturer's choice the test may be performed as, either:

- (a) A vehicle based test in accordance with paragraph 6.5.1. of this Regulation, or
- (b) A component based test in accordance with paragraph 6.5.2. of this Regulation. "

Annex 9C, Mechanical shock, paragraph 3.2. amend to read:

"3.2. Test procedure

The Tested-Device shall be decelerated or accelerated in compliance with the acceleration corridors which are specified in Tables 1 to 43. The manufacturer shall decide whether the tests shall be conducted in either the positive or negative direction or both.

For each of the test pulses specified, a separate Tested-Device may be used.

The test pulse shall be within the minimum and maximum value as specified in Tables 1 to 43. A higher shock level and /or longer duration as described in the maximum value in Tables 1 to 43 can be applied to the Tested-Device if recommended by the manufacturer.

The test shall end with an observation period of 1 hour at the ambient temperature conditions of the test environment.

Figure 1  
Generic Description of Test Pulses

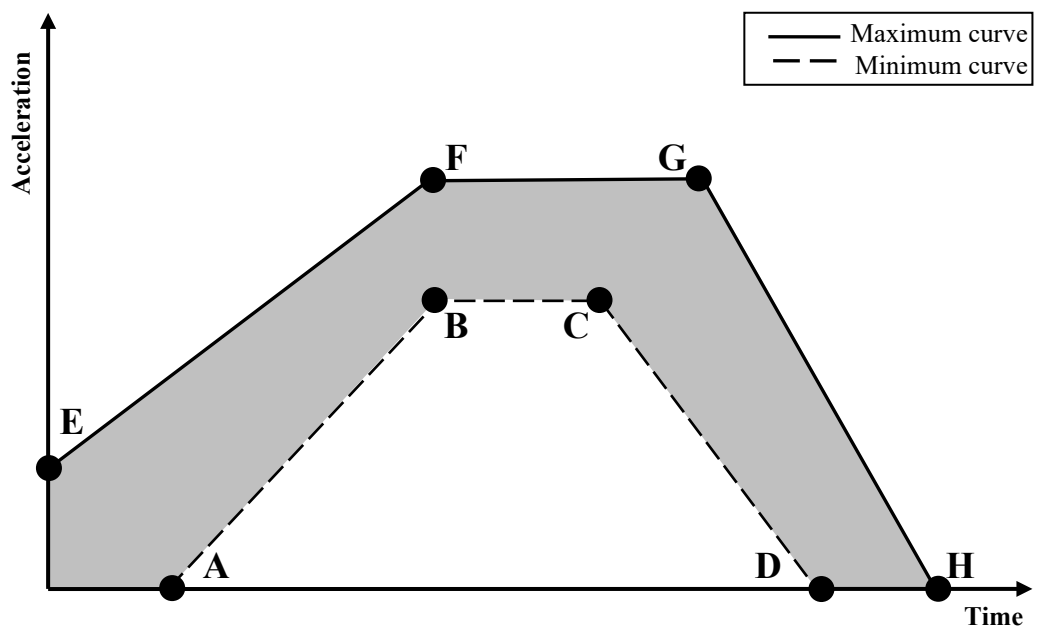

Table 1  
for M<sub>1</sub> and N<sub>1</sub> Vehicles

<i>Point</i>	<i>Time (ms)</i>	<i>Acceleration (g)</i>	
		<i>Longitudinal</i>	<i>Transverse</i>
A	20	0	0
B	50	20	8
C	65	20	8
D	100	0	0
E	0	10	4.5
F	50	28	15
G	80	28	15
H	120	0	0

Table 2  
for M<sub>2</sub> and N<sub>2</sub> Vehicles

<i>Point</i>	<i>Time (ms)</i>	<i>Acceleration (g)</i>	
		<i>Longitudinal</i>	<i>Transverse</i>
A	20	0	0
B	50	10	5
C	65	10	5
D	100	0	0
E	0	5	2.5
F	50	17	10
G	80	17	10
H	120	0	0

Table 3  
for M<sub>3</sub>, and N<sub>3</sub>, O<sub>1</sub>, O<sub>2</sub> Vehicles

<i>Point</i>	<i>Time (ms)</i>	<i>Acceleration (g)</i>	
		<i>Longitudinal</i>	<i>Transverse</i>
A	20	0	0
B	50	6,6	5
C	65	6,6	5
D	100	0	0
E	0	4	2.5
F	50	12	10
G	80	12	10
H	120	0	0

Annex 9C, Mechanical shock, paragraph 3.2. insert new table 4:

**Table 4**  
**for O<sub>3</sub> and O<sub>4</sub> Vehicles**

<i>Point</i>	<i>Time (ms)</i>	<i>Acceleration (g)</i>	
		<i>Longitudinal</i>	<i>Transverse</i>
<b>A</b>	<b>20</b>	<b>0</b>	<b>0</b>
<b>B</b>	<b>50</b>	<b>1</b>	<b>1</b>
<b>C</b>	<b>65</b>	<b>1</b>	<b>1</b>
<b>D</b>	<b>100</b>	<b>0</b>	<b>0</b>
<b>E</b>	<b>0</b>	<b>1</b>	<b>1</b>
<b>F</b>	<b>50</b>	<b>2</b>	<b>2</b>
<b>G</b>	<b>80</b>	<b>2</b>	<b>2</b>
<b>H</b>	<b>120</b>	<b>0</b>	<b>0</b>

The test shall end with an observation period of one hour at the ambient temperature conditions of the test environment."

## II. Justification

### General

1. To tackle climate change, it is needed to significantly reduce CO<sub>2</sub> emissions induced by the transport sector worldwide. The transport sector is an important CO<sub>2</sub> emitter after the energy sector and other industry branches. Therefore, stringent goals for heavy duty vehicles are defined to limit the CO<sub>2</sub> emissions. These ambitious goals will have a major influence on future design of trucks and trailers on roads and it will significantly change the type of propulsion for such vehicle combinations. It might be interesting for a closer look on the potential of trailers to contribute to the overall CO<sub>2</sub> reduction of a vehicle combination. The trailer or semitrailer itself does not emit CO<sub>2</sub> in standstill or driving modes but contribute to the overall CO<sub>2</sub> balance of the vehicle combination. CO<sub>2</sub> values may be assigned to the trailer due to its rolling resistance, its kerb weight and finally the air drag. Therefore, it is logically to think about measures/technologies for a reduction of these emissions. Based on this development trailer manufacturers are urged to contribute to CO<sub>2</sub> reduction by improved trailer design and new technologies now.

2. One of these features is a driven axle in a trailer/semi-trailer (e.g. with propulsion and/or recuperation system). Driven axles in trailers have the potential to support the motor vehicle (e.g. the tractor) during start-stop manoeuvres, during accelerating/braking and during transport of heavy loads under ambitious conditions (uphill/downhill) or may convert the kinetic energy of an axle to supply electric systems (e.g. cooling units for reefer). This leads to lower fuel consumption of the motor vehicle respectively cooling units (ergo lower



CO<sub>2</sub> emissions) and higher agility of the whole vehicle combination. The type of drivetrain may be electrical. The drive train on the trailer/semi-trailer will be controlled to safely follow the towing vehicle. The propelling capacity of any trailer/semi-trailer in a vehicle combination shall be controlled within the vehicle combination in such a way that the longitudinal/lateral stability of the combination is not negatively influenced. The drive train of the trailer/semi-trailer can operate in the full speed range of the vehicle combination and is not limited to low-speed applications. But the pushing of the towing vehicle by the trailer/semi-trailer is not permitted at speeds higher than 15 km/h. The trailer shall always remain in the towed condition with tensile forces in the coupling (except for the starting aid and except pushing forces that result from the normal dynamic conditions of the motor vehicle and trailer while driving/braking as it is usual today). Heavy trailers (category O3 and O4) are predestined to be propelled by an electric engine to reduce the overall CO<sub>2</sub> emission of the tractor/lorry. But also propelled light trailers (category O2) have a huge effect on vehicle dynamics. The use of a trailer (e.g. caravan) is mostly not foreseen in combination with battery electric cars or results in a huge reduction of the range due to the limited battery capacity of a car. This may lead to low acceptance of battery electric cars in a growing market of caravan users. But especially an electric propulsion in a trailer of category O2 (e.g. caravan) would allow the use of this trailer in a combination with a battery electric vehicle. The e-trailer would be able to guarantee the normal range of the battery electric car in combination with the trailer without any further emissions.

3. With respect to potential application of electrical energy storage or electric power train in category O vehicles, there might be several possibilities (see following table). This **CLCCR proposal focuses on the use cases A and E**. The use cases B and C are currently not considered as long the energy transfer between trailer and towing vehicle is not standardized. Use case D describes the possibility for providing energy for equipment without recuperation via external charging. Use case D seems to be possible today without a certification based on UN Regulation No.100 and is therefore also not considered in this proposal.

<i>Use-case</i>	<i>Energy storage</i>	<i>External charging</i>	<i>Energy Recuperation</i>	<i>Propulsion assist (traction motor)</i>	<i>Energy supply to towing vehicle</i>	<i>Energy supply to equipment (e.g. fridge,)</i>
<b>A</b>	<b>Yes</b>	<b>No</b>	<b>Yes</b>	<b>Yes</b>	<b>No</b>	<b>Yes/No</b>
B	Yes	Yes	Yes	Yes	Yes	Yes/No
C	Yes	Yes	No	No	Yes	Yes/No
D	Yes	Yes	No	No	No	Yes/No
<b>E</b>	<b>Yes</b>	<b>Yes</b>	<b>Yes</b>	<b>Yes</b>	<b>No</b>	<b>Yes/No</b>

4. **Paragraphs 1.1. and 1.2.:** Vehicles of category equipped with a propulsion to support the movement of the towing vehicle are intended to use high voltage components including traction batteries (REESS). Therefore the scope should be amended by vehicles of category O.

5. **Paragraph 2.1.:** The status of the "Active driving possible mode" should be amended by the trailer, which makes clear that the trailers propulsion supports the movement of the towing vehicle.

6. **Paragraph 5.1.1.:** The requirements for the Protection against direct contact have to be considered by vehicles of category O. Nevertheless vehicles of category O3 and O4 are to be compared in size and use with vehicles in category N2, N3. Therefore O3 and O4 should comply with the requirements for N2, N3.

7. **Paragraph 5.1.1.3.:** The requirements for the protection against direct contact have to be considered by vehicles of category O. Nevertheless vehicles of category O3 and O4 are to be compared in size and use with vehicles in category N2, N3. Therefore O3 and O4 should comply with the requirements for N2, N3.

8. **Paragraph 5.1.1.4.2.:** The requirements for the protection against direct contact have to be considered by vehicles of category O. Nevertheless vehicles of category O3 and O4 are to be compared in size and use with vehicles in category N2, N3. Therefore O3 and O4 should comply with the requirements for N2, N3.
9. **Paragraph 5.1.3.2.:** The word "motor" is mis-leading in cases of vehicles of category O. This word may be deleted.
10. **Paragraphs 5.2.3.:** In case of an event of failure in REESS of the trailer the consequences are different from the consequences of a failure of REESS in the motor vehicle. The trailer is per definition a towed vehicle and driving dynamics of the driven trailer doesn't harm the driving of the vehicle combination. **It is proposed that the trailer is able to transmit a warning by using a wired or wireless interface. This is also requested in UN Regulation 141 and the provisions base on an open standard. For Trailers of category O3 and O4 the transmission via the CAN bus based on ISO 11992 is also an option.**
11. **Paragraph 5.2.4.:** Low battery content in the trailers leads to an automatic stop of any support functionalities. This means the trailer operates then **as** a normal trailer without propulsion. Therefore a warning is not necessary.
12. **Paragraphs 5.3.1. and 5.3.2.:** The preventing of an accidental or unintended vehicle movement of a trailer is essential to guarantee the safe driving. Therefore it must ensure that the trailer propulsion is controlled by the towing vehicle. This means a signal from the towing vehicle to the trailer or a force-sensitive coupling devices controls the trailer propulsion.
13. **Paragraph 5.3.3. and new figure 3:** In cases when the trailer REESS is charged externally ~~the trailer shall provide an audible warning if a trailer movement is detected.~~ **Furthermore** an instruction to use wheel chocks is to be placed on a label near the trailer inlet.
14. **Paragraph 6.5.:** The purpose of this test, specified in annex 9E is to verify the resistance of the REESS, against exposure to fire from outside of the vehicle due to, e.g. a fuel spill from a vehicle (either the vehicle itself or a nearby vehicle). This situation should leave the driver and passengers with enough time to evacuate. For vehicles of category O **as long as the REESS is installed outside the trailer loading compartment** the requirements regarding fire resistance are not relevant for the evacuation time of the driver of the towing vehicle.
15. **Annex 9C Mechanical shock Paragraphs 3.2.:** The resistance against mechanical shock focuses on pulses of crash tests or similar performance tests of vehicles of categories N1, N2, N3, M1, M2 and M3. Trailers are normally not in the scope of crash test regulations due to the absence of passengers. Therefore it is recommended to define basic performance pulses for trailers in relation to the category of the trailer. REESS on O1/O2 may be tested with the pulse as defined for N3. REESS for O3/O4 may be tested with a pulse related to requirements about the ADR ("Agreement concerning the International Carriage of Dangerous Goods by Road " – Transport of dangerous goods) UNECE.
-