

# Status Report of the Informal Working Group on Safer Transport of Children in Buses and Coaches (IWG-STCBC)

---

71st GRSP Session  
9 – 13 May 2022

CHAIR: MARTA ANGLÈS , SPAIN

SECRETARY: FARID BENDJELLAL, CLEPA

# Informal Working Group

---

## Last meeting

⊕ 9<sup>th</sup> IWG-STCBC meeting

Date: 1<sup>st</sup> 2<sup>nd</sup> March 2022

Location: Online meeting

## Next meeting

⊕ 10<sup>th</sup> IWG-STCBC meeting

Date: 18<sup>th</sup> 19<sup>th</sup> May 2022

Location: Online meeting

# Timeline

## Plan and Schedule

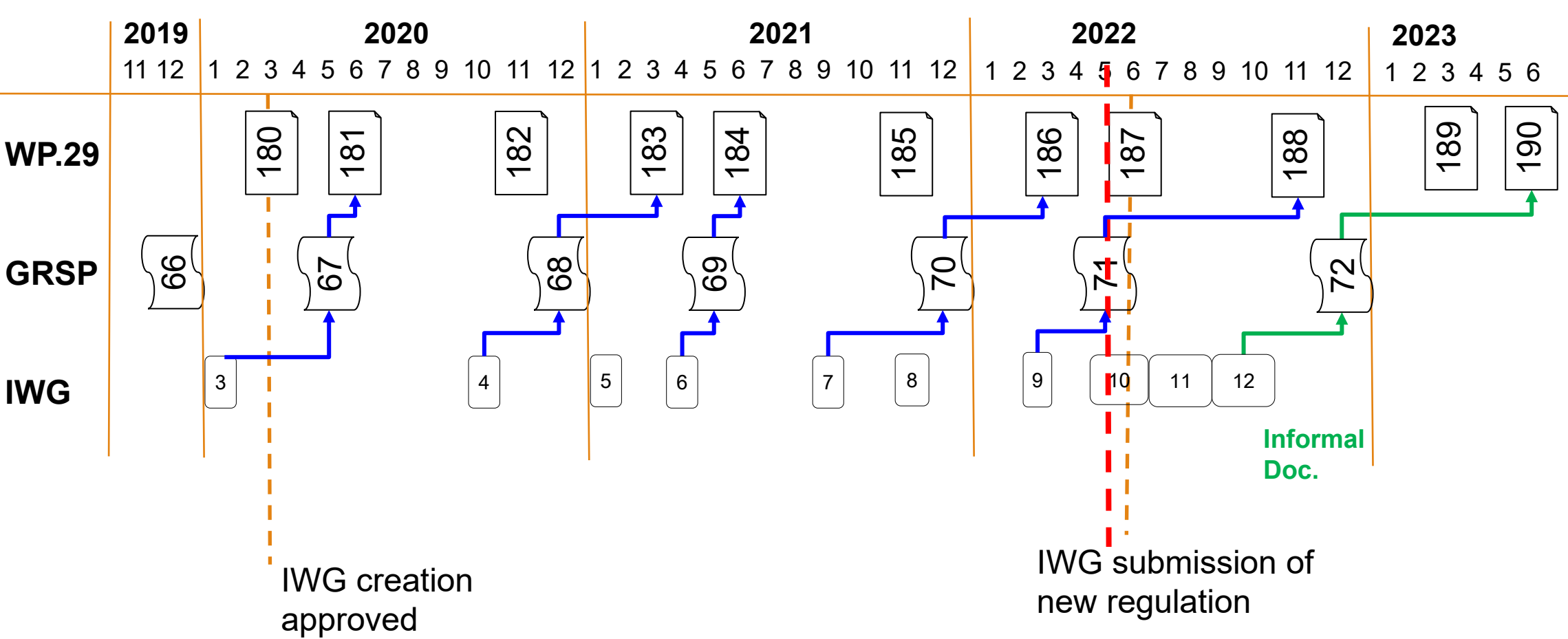

# Summary of the new UN Regulation

Summary	
Time line	GRSP- December 2022 WP.29 - 2023
Objective	No ejection of the children. Good retention in the seat
Phase 1	a: CRS approved according to R-129 with 3-point belt and or ISOFIX b: Built in systems
Phase 2	CRS in combination with 2-point belts

# Decisions made in the IWG To be confirmed by GRSP

Decision	Comments	Status
Class of vehicles under the scope	All of them (Excluding Class I and A) Phase 1: Class B and III Phase 2: Other classes	Closed. To be discussed/adopted by GRSP.
How to test	Phase 1a: CRS approved according to R-129, no new tests required, if they can fit in the bus/coach seats. Phase 1b: Definition of the tests for built-in system	Closed. To be discussed/adopted by GRSP.
Dynamic tests	Q dummies; R-129 criteria	Closed. To be discussed/adopted by GRSP.
2-point belt? 3-point belt?	Phase 1a: Focusing only in 3-point belts and/or ISOFIX Phase 2: CRs in combination with 2-point belt	Closed. To be discussed/adopted by GRSP.
Occupants scenario	The IWG will focus on the requirements of the new UN Regulation as there are options in the market which are compatible. National legislation to define how many seating positions shall be available for children in the buses/coaches	Closed. To be discussed/adopted by GRSP.

# Open discussions

Discussion	Comments	Status
Dynamic test	Seat distances: R-107? Or R-80? Dynamic test, only the space considered? As in R-129? Maximum head excursion? Or 2 seat rows installed to check the HIC in case of impact against the front row?	Ongoing
Definition of the test bench	Phase 1a: No need of a test bench. Phase 1b: Built-in to be tested with the vehicle actual seat. Phase 2: To define a test bench representative of the bus seats.	Ongoing

# Next Steps

---

- ⊕ Drafting the UN Regulation
  - Defining requirements
  - Developing tests procedures

Thank you for your attention!

---