

23 March 2022

Agreement

Concerning the Adoption of Harmonized Technical United Nations Regulations for Wheeled Vehicles, Equipment and Parts which can be Fitted and/or be Used on Wheeled Vehicles and the Conditions for Reciprocal Recognition of Approvals Granted on the Basis of these United Nations Regulations *

(Revision 3, including the amendments which entered into force on 14 September 2017)

Addendum 99: Regulation No. 100

Revision 3

Incorporating all valid text up to:

Supplement 1 to the 02 series of amendments – Date of entry into force: 10 June 2014

Supplement 2 to the 02 series of amendments – Date of entry into force: 29 January 2016

Supplement 3 to the 2 series of amendments – Date of entry into force: 18 June 2016

Supplement 4 to the 02 series of amendments – Date of entry into force: 28 May 2019

03 series of amendments to the UN Regulation – Date of entry into force: 9 June 2021

* Former titles of the Agreement:

Agreement Concerning the Adoption of Uniform Conditions of Approval and Reciprocal Recognition of Approval for Motor Vehicle Equipment and Parts, done at Geneva on 20 March 1958 (original version);

Agreement concerning the Adoption of Uniform Technical Prescriptions for Wheeled Vehicles, Equipment and Parts which can be Fitted and/or be Used on Wheeled Vehicles and the Conditions for Reciprocal Recognition of Approvals Granted on the Basis of these Prescriptions, done at Geneva on 5 October 1995 (Revision 2).



Uniform provisions concerning the approval of vehicles with regard to specific requirements for the electric power train



UNITED NATIONS

The authentic and legal binding texts are:

- ECE/TRANS/WP.29/2013/135 as amended by ECE/TRANS/WP.29/1106, para.61
- ECE/TRANS/WP.29/2015/52
- ECE/TRANS/WP.29/2015/98
- ECE/TRANS/WP.29/2018/135
- ECE/TRANS/WP.29/2020/109

Regulation No. 100

Uniform provisions concerning the approval of vehicles with regard to specific requirements for the electric power train

Contents

	<i>Page</i>
Regulation	
1. Scope	5
2. Definitions.....	5
3. Application for approval	9
4. Approval	9
5. Part I: Requirements of a vehicle with regard to specific requirements for the electric power train	10
6. Part II: Requirements of a Rechargeable Electrical Energy Storage System (REESS) with regard to its safety	16
7. Modifications and extension of the type approval.....	25
8. Conformity of production.....	26
9. Penalties for non-conformity of production	26
10. Production definitively discontinued.....	27
11. Names and addresses of Technical Services responsible for conducting approval tests and of Type Approval Authorities	27
12. Transitional provisions.....	27
Annexes	
1 Part 1 - Communication concerning the approval or extension or refusal or withdrawal of approval or production definitively discontinued of a vehicle type with regard to its electrical safety pursuant to Regulation No. 100	28
1 Part 2 - Communication concerning the approval or extension or refusal or withdrawal of approval or production definitively discontinued of a REESS type as component/separate technical unit pursuant to Regulation No. 100.....	30
1 Appendix 1	32
1 Appendix 2	34
2 Arrangements of the approval marks	35
3 Protection against direct contacts of parts under voltage	36
4 Verification of potential equalization.....	39
5A Isolation resistance measurement method for vehicle based tests	40
5B Isolation resistance measurement method for component based tests of a REESS.....	44
6 Confirmation method for function of on-board isolation resistance monitoring system	47
7A Verification method for testing authorities confirming document based isolation resistance compliance of electrical design of the vehicle after water exposure	48
7B Vehicle-based test procedure for protection against water effects	51
8 Determination of hydrogen emissions during the charge procedures of the REESS.....	52

	Appendix 1 - Calibration of equipment for hydrogen emission testing.....	62
	Appendix 2 - Essential characteristics of the vehicle family.....	66
9	REESS test procedures.....	67
	Appendix 1 - Procedure for conducting a standard cycle.....	68
	Appendix 2 – Procedure for SOC adjustment	69
9A	Vibration test.....	70
9B	Thermal shock and cycling test	72
9C	Mechanical shock.....	73
9D	Mechanical integrity.....	76
9E	Fire resistance.....	78
	Appendix 1 - Dimension and technical data of firebricks	83
9F	External short circuit protection	84
9G	Overcharge protection	86
9H	Over-discharge protection	89
9I	Over-temperature protection	92
9J	Over-current protection	94

1. Scope

- 1.1. Part I: Safety requirements with respect to the electric power train of road vehicles of categories M and N¹, with a maximum design speed exceeding 25 km/h, equipped with electric power train, excluding vehicles permanently connected to the grid.

Part I of this regulation does not cover;

- (a) Post-crash safety requirements of road vehicles.
- (b) High voltage components and systems which are not galvanically connected to the high voltage bus of the electric power train.

- 1.2. Part II: Safety requirements with respect to the Rechargeable Electrical Energy Storage System (REESS), of road vehicles of categories M and N equipped with electric power train, excluding vehicles permanently connected to the grid.

Part II of this Regulation does not apply to a battery whose primary use is to supply power for starting the engine and/or lighting and/or other vehicle auxiliaries' systems..

2. Definitions

For the purpose of this Regulation the following definitions apply:

- 2.1. "*Active driving possible mode*" means the vehicle mode when application of pressure to the accelerator pedal (or activation of an equivalent control) or release of the brake system will cause the electric power train to move the vehicle.
- 2.2. "*Aqueous electrolyte*" means an electrolyte based on water solvent for the compounds (e.g. acids, bases) providing conducting ions after its dissociation.
- 2.3. "*Automatic disconnect*" means a device that when triggered, conductively separates the electric energy sources from the rest of the high voltage circuit of the electric power train.
- 2.4. "*Breakout harness*" means connector wires that are connected for testing purposes to the REESS on the traction side of the automatic disconnect
- 2.5. "*Cell*" means a single encased electrochemical unit containing one positive and one negative terminals, which exhibits a voltage differential across its two terminals and used as rechargeable electrical energy storage device.
- 2.6. "*Conductive connection*" means the connection using connectors to an external power supply when the Rechargeable Electrical Energy Storage System (REESS) is charged.
- 2.7. "*Connector*" means the device that provides mechanical connection and disconnection of high voltage electrical conductors to a suitable mating component including its housing
- 2.8. "*Coupling system for charging the Rechargeable Electrical Energy Storage System (REESS)*" means the electrical circuit used for charging the REESS from an external electric power supply including the vehicle inlet.

¹ As defined in the Consolidated Resolution on the Construction of Vehicles (R.E.3.), document ECE/TRANS/WP.29/78/Rev.6, para. 2
<https://unece.org/transport/standards/transport/vehicle-regulations-wp29/resolutions>

- 2.9. "*C Rate*" of "*n C*" is defined as the constant current of the Tested-DeviceTested-Device, which takes 1/n hours to charge or discharge the Tested-DeviceTested-Device between 0 per cent of the state of charge and 100 per cent of the state of charge.
- 2.10. "*Direct contact*" means the contact of persons with high voltage live parts.
- 2.11. "*Electric energy conversion system*" means a system (e.g. fuel cell) that generates and provides electric energy for electric propulsion.
- 2.12. "*Electric power train*" means the electrical circuit which includes the traction motor(s), and may include the REESS, the electric energy conversion system, the electronic converters, the associated wiring harness and connectors, and the coupling system for charging the REESS.
- 2.13. "*Electrical chassis*" means a set made of conductive parts electrically linked together, whose potential is taken as reference.
- 2.14. "*Electrical circuit*" means an assembly of connected live parts which is designed to be electrically energized in normal operation.
- 2.15. "*Electrical protection barrier*" means the part that provides protection against direct contact with the high voltage live parts.
- 2.16. "*Electrolyte leakage*" means the escape of electrolyte from the REESS in the form of liquid
- 2.17. "*Electronic converter*" means a device capable of controlling and/or converting electric power for electric propulsion.
- 2.18. "*Enclosure*" means the part enclosing the internal units and providing protection against any direct contact.
- 2.19. "*Explosion*" means the sudden release of energy sufficient to cause pressure waves and/or projectiles that may cause structural and/or physical damage to the surrounding of the Tested-DeviceTested-Device.
- 2.20. "*Exposed conductive part*" means the conductive part which can be touched under the provisions of the protection degree IPXXB, and which is not normally energized, but which can become electrically energized under isolation failure conditions. This includes parts under a cover that can be removed without using tools.
- 2.21. "*External electric power supply*" means an alternating current (AC) or direct current (DC) electric power supply outside of the vehicle.
- 2.22. "*Fire*" means the emission of flames from a Tested-Device. Sparks and arcing shall not be considered as flames.
- 2.23. "*Flammable electrolyte*" means an electrolyte that contains substances classified as Class 3 "flammable liquid" under "UN Recommendations on the Transport of Dangerous Goods – Model Regulations (Revision 17 from June 2011), Volume I, Chapter 2.3"²
- 2.24. "*High Voltage*" means the classification of an electric component or circuit, if its working voltage is > 60 V and ≤ 1500 V DC or > 30 V and ≤ 1000 V AC root mean square (rms).
- 2.25. "*High voltage bus*" means the electrical circuit, including the coupling system for charging the REESS that operates on high voltage. In case of electrical circuits, that are galvanically connected to each other and fulfilling the voltage condition specified in paragraph 2.42., only the components or parts of the electric circuit that operate on high voltage are classified as a high voltage bus.

² www.unece.org/trans/danger/publi/unrec/rev17/17files_e.html

- 2.26. "*Indirect contact*" means the contact of persons with exposed conductive parts.
- 2.27. "*Live parts*" means the conductive part(s) intended to be electrically energized under normal operating conditions.
- 2.28. "*Luggage compartment*" means the space in the vehicle for luggage accommodation, bounded by the roof, hood, floor, side walls, as well as by the barrier and enclosure provided for protecting the occupants from direct contact with high voltage live parts, being separated from the passenger compartment by the front bulkhead or the rear bulk head.
- 2.29. "*Manufacturer*" means the person or body who is responsible to the approval authority for all aspects of the approval process and for ensuring conformity of production. It is not essential that the person or body is directly involved in all stages of the construction of the vehicle or component which is the subject of the approval process
- 2.30. "*Non-aqueous electrolyte*" means an electrolyte not based on water as the solvent.
- 2.31. "*Normal operating conditions*" includes operating modes and conditions that can reasonably be encountered during typical operation of the vehicle including driving at legally posted speeds, parking and standing in traffic, as well as, charging using chargers that are compatible with the specific charging ports installed on the vehicle. It does not include conditions where the vehicle is damaged, either by a crash, road debris or vandalism, subjected to fire or water submersion, or in a state where service and or maintenance is needed or being performed.
- 2.32. "*On-board isolation resistance monitoring system*" means the device which monitors the isolation resistance between the high voltage buses and the electrical chassis.
- 2.33. "*Open type traction battery*" means a liquid type battery requiring refilling with water and generating hydrogen gas released to the atmosphere.
- 2.34. "*Passenger compartment*" means the space for occupant accommodation, bounded by the roof, floor, side walls, doors, window glass, front bulkhead and rear bulkhead, or rear gate, as well as by the barriers and enclosures provided for protecting the occupants from direct contact with live parts.
- 2.35. "*Protection degree IPXXB*" means protection from contact with high voltage live parts provided by either an electrical protection barrier or an enclosure and tested using a Jointed Test Finger (IPXXB) as described in Annex 3.
- 2.36. "*Protection degree IPXXD*" means protection from contact with high voltage live parts provided by either an electrical protection barrier or an enclosure and tested using a Test Wire (IPXXD) as described in Annex 3.
- 2.37. "*Rechargeable Electrical Energy Storage System (REESS)*" means the rechargeable energy storage system that provides electric energy for electrical propulsion.
- A battery whose primary use is to supply power for starting the engine and/or lighting and/or other vehicle auxiliaries' systems is not considered as a REESS.
- The REESS may include the necessary systems for physical support, thermal management, electronic controls and casing
- 2.38. "*REESS subsystem*" means any assembly of REESS components which stores energy. A REESS subsystem may or may not include the entire management system of the REESS.

- 2.39. "*Rupture*" means opening(s) through the casing of any functional cell assembly created or enlarged by an event, large enough for a 12 mm diameter test finger (IPXXB) to penetrate and make contact with live parts (see Annex 3).
- 2.40. "*Service disconnect*" means the device for deactivation of the electrical circuit when conducting checks and services of the REESS, fuel cell stack, etc.
- 2.41. "*Solid insulator*" means the insulating coating of wiring harnesses provided in order to cover and prevent the high voltage live parts from any direct contact
- 2.42. "*Specific voltage condition*" means the condition that the maximum voltage of a galvanically connected electrical circuit between a DC live part and any other live part (DC or AC) is ≤ 30 V AC (rms) and ≤ 60 V DC.
- Note: When a DC live part of such an electrical circuit is connected to chassis and the specific voltage condition applies, the maximum voltage between any live part and the electrical chassis is ≤ 30 V AC (rms) and ≤ 60 V DC
- 2.43. "*State of Charge (SOC)*" means the available electrical charge in a Tested-DeviceTested-Device expressed as a percentage of its rated capacity.
- 2.44. "*Tested-Device*" means either complete REESS or REESS subsystem that is subjected to the tests prescribed by this Regulation.
- 2.45. "*Thermal event*" means the condition when the temperature within the REESS is significantly higher (as defined by the manufacturer) than the maximum operating temperature.
- 2.46. "*Thermal runaway*" means an uncontrolled increase of cell temperature caused by exothermic reactions inside the cell.
- 2.47. "*Thermal propagation*" means the sequential occurrence of thermal runaway within a REESS triggered by thermal runaway of a cell in that REESS.
- 2.48. "*Type of REESS*" means systems which do not differ significantly in such essential aspects as:
- (a) The manufacturer's trade name or mark;
 - (b) The chemistry, capacity and physical dimensions of its cells;
 - (c) The number of cells, the mode of connection of the cells and the physical support of the cells;
 - (d) The construction, materials and physical dimensions of the casing and
 - (e) The necessary ancillary devices for physical support, thermal management and electronic control.
- 2.49. "*Vehicle connector*" means the device which is inserted into the vehicle inlet to supply electric energy to the vehicle from an external electric power supply.
- 2.50. "*Vehicle inlet*" means the device on the externally chargeable vehicle into which the vehicle connector is inserted for the purpose of transferring electric energy from an external electric power supply.
- 2.51. "*Vehicle type*" means vehicles which do not differ in such essential aspects as:
- (a) Installation of the electric power train and the galvanically connected high voltage bus;
 - (b) Nature and type of electric power train and the galvanically connected high voltage components.

- 2.52. "Venting" means the release of excessive internal pressure from cell or REESS subsystem or REESS in a manner intended by design to preclude rupture or explosion."
- 2.53. "Working voltage" means the highest value of an electrical circuit voltage root-mean-square (rms), specified by the manufacturer, which may occur between any conductive parts in open circuit conditions or under normal operating condition. If the electrical circuit is divided by galvanic isolation, the working voltage is defined for each divided circuit, respectively.

3. Application for approval

- 3.1. Part I: Approval of a vehicle type with regard to specific requirements for the electric power train.
- 3.1.1. The application for approval of a vehicle type with regard to specific requirements for the electric power train shall be submitted by the vehicle manufacturer or by his duly accredited representative.
- 3.1.2. It shall be accompanied by the under-mentioned documents in triplicate and following particulars:
- 3.1.2.1. Detailed description of the vehicle type with regards to the electric power train and the high voltage bus galvanically connected to it.
- 3.1.2.2. For vehicles with REESS, additional evidence showing that the REESS is in compliance with the requirements of paragraph 6. of this Regulation.
- 3.1.3. A vehicle representative of the vehicle type to be approved shall be submitted to the Technical Service responsible for conducting the approval tests and, if applicable, at the manufacturer's discretion with the agreement of the Technical Service, either additional vehicle(s), or those parts of the vehicle regarded by the Technical Service as essential for the test(s) referred to in the paragraph 6. of this Regulation.
- 3.2. Part II: Approval of a Rechargeable Electrical Energy Storage System (REESS)
- 3.2.1. The application for approval of a type of REESS with regard to the safety requirements of the REESS shall be submitted by the REESS manufacturer or by his duly accredited representative.
- 3.2.2. It shall be accompanied by the under-mentioned documents in triplicate and comply with the following particulars:
- 3.2.2.1. Detailed description of the type of REESS as regards the safety of the REESS.
- 3.2.3. A component(s) representative of the type of REESS to be approved plus, at the manufacturer's discretion, and with the agreement of the Technical Service, those parts of the vehicle regarded by the Technical Service as essential for the test, shall be submitted to the Technical Service responsible for conducting the approval tests.
- 3.3. The Type Approval Authority shall verify the existence of satisfactory arrangements for ensuring effective control of the conformity of production before type approval is granted.

4. Approval

- 4.1. An approval number shall be assigned to each approved type in accordance with Schedule 4 of the Agreement (E/ECE/TRANS/505/Rev.3).

- 4.2. Notice of approval or of refusal or of extension or withdrawal of approval or production definitively discontinued of a vehicle type pursuant to this Regulation shall be communicated to the Parties to the Agreement applying this Regulation, by means of a form conforming to the model in Annex 1, Part 1 or 2 as appropriate to this Regulation.
- 4.3. There shall be affixed, conspicuously and in a readily accessible place specified on the approval form, to every vehicle or REESS conforming to a type approved under this Regulation an international approval mark consisting of:
 - 4.3.1. A circle surrounding the letter "E" followed by the distinguishing number of the country which has granted approval³.
 - 4.3.2. The number of this Regulation, followed by the letter "R", a dash and the approval number to the right of the circle described in paragraph 4.3.1.
 - 4.3.3. In the case of an approval of a REESS the "R" shall be followed by the symbol "ES".
- 4.4. If the vehicle or REESS conforms to a type approved under one or more other Regulations annexed to the Agreement in the country which has granted approval under this Regulation, the symbol prescribed in paragraph 4.3.1. need not be repeated; in this case the Regulation and approval numbers and the additional symbols of all the Regulations under which approval has been granted in the country which has granted approval under this Regulation shall be placed in vertical columns to the right of the symbol prescribed in paragraph 4.3.1.
- 4.5. The approval mark shall be clearly legible and shall be indelible.
 - 4.5.1. In the case of a vehicle, the approval mark shall be placed on or close to the vehicle data plate affixed by the manufacturer.
 - 4.5.2. In the case of a REESS, the approval mark shall be affixed on the major element of the REESS by the manufacturer.
- 4.6. Annex 2 to this Regulation gives examples of the arrangements of the approval mark.

5. Part I: Requirements of a vehicle with regard to specific requirements for the electric power train

- 5.1. Protection against electrical shock

These electrical safety requirements apply to high voltage buses of electric power train and electrical components which are galvanically connected to the high voltage bus of electric power train under conditions where they are not connected to external high voltage power supplies.
- 5.1.1. Protection against direct contact

Live parts shall comply with paragraphs 5.1.1.1. and 5.1.1.2. for protection against direct contact. Electrical protection barriers, enclosures, solid insulators and connectors shall not be able to be opened, separated, disassembled or removed without the use of tools or, for vehicles of categories N₂, N₃, M₂ and M₃, an operator controlled activation/deactivation device or equivalent.

³ The distinguishing numbers of the Contracting Parties to the 1958 Agreement are reproduced in Annex 3 to Consolidated Resolution on the Construction of Vehicles (R.E.3), document ECE/TRANS/WP.29/78/Rev.2/Amend.3

However, connectors (including the vehicle inlet) are allowed to be separated without the use of tools, if they meet one or more of the following requirements:

- (a) They comply with paragraphs 5.1.1.1. and 5.1.1.2. when separated, or
- (b) They are provided with a locking mechanism (at least two distinct actions are needed to separate the connector from its mating component). Additionally, other components, not being part of the connector, shall be removable only with the use of tools or, for vehicles of categories N₂, N₃, M₂ and M₃, an operator controlled activation/deactivation device or equivalent in order to be able to separate the connector, or
- (c) The voltage of the live parts becomes equal or below 60 V DC or equal or below 30 V AC (rms) within 1 s after the connector is separated.

For vehicles of categories N₂, N₃, M₂ and M₃, conductive connection devices not energized except during charging of the REESS are exempted from this requirement if located on the roof of the vehicle out of reach for a person standing outside of the vehicle and, for vehicles of category M₂ and M₃, the minimum wrap around distance from the instep of the vehicle to the roof mounted charging devices is 3 m. In case of multiple steps due to an elevated floor inside the vehicle, the wrap around distance is measured from the bottom most step at entry, as illustrated in Figure 1.

Figure 1
Schematic to Measure Wrap-Around Distance

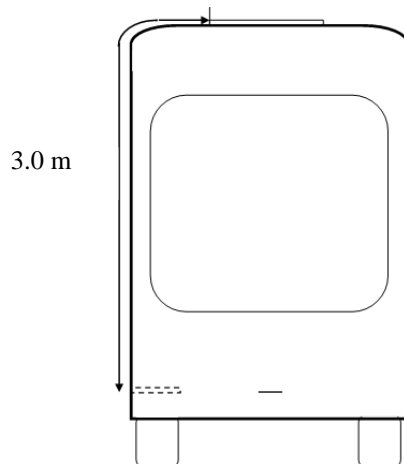

- 5.1.1.1. For high voltage live parts inside the passenger compartment or luggage compartment, the protection degree IPXXD shall be provided.
- 5.1.1.2. For high voltage live parts in areas other than the passenger compartment or luggage compartment, the protection degree IPXXB shall be provided.
- 5.1.1.3. Service disconnect
For a high voltage service disconnect which can be opened, disassembled or removed without tools, or for vehicles of categories N₂, N₃, M₂ and M₃, an operator controlled activation/deactivation device or equivalent, protection degree IPXXB shall be satisfied when it is opened, disassembled or removed.
- 5.1.1.4. Marking
 - 5.1.1.4.1. The symbol shown in Figure 2 shall be present on or near the REESS having high voltage capability. The symbol background shall be yellow, the bordering and the arrow shall be black.

This requirement shall also apply to a REESS which is part of a galvanically connected electrical circuit where the specific voltage condition is not fulfilled, independent of the maximum voltage of the REESS.

Figure 2

Marking of High Voltage Equipment

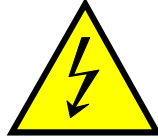

- 5.1.1.4.2. The symbol shall also be visible on enclosures and electrical protection barriers, which, when removed, expose live parts of high voltage circuits. This provision is optional to any connector for high voltage buses. This provision shall not apply to any of the following cases:
- (a) Where electrical protection barriers or enclosures cannot be physically accessed, opened, or removed; unless other vehicle components are removed with the use of tools;
 - (b) Where electrical protection barriers or enclosures are located underneath the vehicle floor.
 - (c) Electrical protection barriers or enclosures of conductive connection device for vehicles of categories N2, N3, M2 and M3 which satisfies the conditions prescribed in paragraph 5.1.1.
- 5.1.1.4.3. Cables for high voltage buses which are not located within enclosures shall be identified by having an outer covering with the colour orange.
- 5.1.2. Protection against indirect contact
- 5.1.2.1. For protection against electrical shock which could arise from indirect contact, the exposed conductive parts, such as the conductive electrical protection barrier and enclosure, shall be galvanically connected securely to the electrical chassis by connection with electrical wire or ground cable, or by welding, or by connection using bolts, etc. so that no dangerous potentials are produced.
- 5.1.2.2. The resistance between all exposed conductive parts and the electrical chassis shall be lower than 0.1 Ω when there is current flow of at least 0.2 amperes.
- The resistance between any two simultaneously reachable exposed conductive parts of the electrical protection barriers that are less than 2.5 m from each other shall not exceed 0.2 Ω . This resistance may be calculated using the separately measured resistances of the relevant parts of electric path.
- This requirement is satisfied if the galvanic connection has been established by welding. In case of doubt or if the connection is established by other means than welding, a measurement shall be made by using one of the test procedures described in Annex 4.
- 5.1.2.3. In the case of motor vehicles which are intended to be connected to the grounded external electric power supply through the conductive connection between vehicle inlet and vehicle connector, a device to enable the galvanical connection of the electrical chassis to the earth ground for the external electric power supply shall be provided.

The device should enable connection to the earth ground before exterior voltage is applied to the vehicle and retain the connection until after the exterior voltage is removed from the vehicle.

Compliance to this requirement may be demonstrated either by using the connector specified by the vehicle manufacturer, by visual inspection or drawings.

The above requirements are only applicable for vehicles when charging from a stationary charging point, with a charging cable of finite length, through a vehicle coupler comprising a vehicle connector and a vehicle inlet.

5.1.3. Isolation resistance

This paragraph shall not apply to electrical circuits that are galvanically connected to each other, where the DC part of these circuits is connected to the electrical chassis and the specific voltage condition is fulfilled.

5.1.3.1. Electric power train consisting of separate Direct Current- or Alternating Current-buses

If AC high voltage buses and DC high voltage buses are galvanically isolated from each other, isolation resistance between the high voltage bus and the electrical chassis shall have a minimum value of 100 Ω /volt of the working voltage for DC buses, and a minimum value of 500 Ω /volt of the working voltage for AC buses.

The measurement shall be conducted according to Annex 5A "Isolation resistance measurement method for vehicle based tests".

5.1.3.2. Electric power train consisting of combined DC- and AC-buses

If AC high voltage buses and DC high voltage buses are galvanically connected, isolation resistance between the high voltage bus and the electrical chassis shall have a minimum value of 500 Ω /volt of the working voltage.

However, if all AC high voltage buses are protected by one of the two following measures, isolation resistance between the high voltage bus and the electrical chassis shall have a minimum value of 100 Ω /V of the working voltage:

- (a) At least two or more layers of solid insulators, electrical protection barriers or enclosures that meet the requirement in paragraph 5.1.1. independently, for example wiring harness;
- (b) Mechanically robust protections that have sufficient durability over vehicle service life such as motor housings, electronic converter cases or connectors;

The isolation resistance between the high voltage bus and the electrical chassis may be demonstrated by calculation, measurement or a combination of both.

The measurement shall be conducted according to Annex 5A "Isolation resistance measurement method for vehicle based tests".

5.1.3.3. Fuel cell vehicles

In fuel cell vehicles, DC high voltage buses shall have an on-board isolation resistance monitoring system together with a warning to the driver if the isolation resistance drops below the minimum required value of 100 Ω /V. The function of the on-board isolation resistance monitoring system shall be confirmed as described in Annex 6.

The isolation resistance between the high voltage bus of the coupling system for charging the REESS, which is not energized in conditions other than that

during the charging of the REESS, and the electrical chassis need not to be monitored.

5.1.3.4. Isolation resistance requirement for the coupling system for charging the REESS

For the vehicle conductive connection device intended to be conductively connected to the grounded external AC power supply and the electrical circuit that is galvanically connected to the vehicle conductive connection device during charging of the REESS, the isolation resistance between the high voltage bus and the electrical chassis shall comply with the requirements of paragraph 5.1.3.1. when the conductive connection is disconnected and the isolation resistance is measured at the high voltage live parts (contacts) of the vehicle conductive connection device. During the measurement, the REESS may be disconnected.

5.1.4. Protection against water effects.

The vehicles shall maintain isolation resistance after exposure to water (e.g. washing, driving through standing water). This paragraph shall not apply to electrical circuits that are galvanically connected to each other, where the DC part of these circuits is connected to the electrical chassis and the specific voltage condition is fulfilled.

5.1.4.1. The vehicle manufacturer can choose to comply with requirements specified in paragraph 5.1.4.2., those specified in paragraph 5.1.4.3., or those specified in paragraph 5.1.4.4.

5.1.4.2. The vehicle manufacturers shall provide evidence and/or documentation to the type-approval authority or technical services as applicable on how the electrical design or the components of the vehicle located outside the passenger compartment or externally attached, after water exposure remain safe and comply with the requirements described in Annex 7A. If the evidence and/or documentation provided is not satisfactory the type-approval authority or technical services or testing entity as applicable shall require the manufacturer to perform a physical component test based on the same specifications as those described in Annex 7A.

5.1.4.3. If the test procedures specified in Annex 7B are performed, just after each exposure, and with the vehicle still wet, the vehicle shall then comply with isolation resistance test given in Annex 5A, and the isolation resistance requirements given in paragraph 5.1.3. shall be met. In addition, after a 24 hour pause, the isolation resistance test specified in Annex 5A shall again be performed, and the isolation resistance requirements given in paragraph 5.1.3. shall be met.

5.1.4.4. If an isolation resistance monitoring system is provided, and the isolation resistance less than the requirements given in paragraph 5.1.3. is detected, a warning shall be indicated to the driver. The function of the on-board isolation resistance monitoring system shall be confirmed as described in Annex 6.

5.2. Rechargeable Electrical Energy Storage System (REESS)

5.2.1. For a vehicle with a REESS, the requirement of either paragraph 5.2.1.1. or paragraph 5.2.1.2. shall be satisfied.

5.2.1.1. For a REESS which has been type approved in accordance with Part II of this series of Amendments to this Regulation, it shall be installed in accordance with the instructions provided by the manufacturer of the REESS, and in conformity with the description provided in Annex 1, Appendix 2 to this Regulation.

- 5.2.1.2. The REESS including related vehicle components, systems and structure as applicable, shall comply with the respective requirements of paragraph 6. of this Regulation.
- 5.2.2. Accumulation of gas
Places for containing open type traction batteries that may produce hydrogen gas shall be provided with a ventilation fan or a ventilation duct to prevent the accumulation of hydrogen gas.
- 5.2.3. Warning in the event of failure in REESS
The vehicle shall provide a warning to the driver when the vehicle is in active driving possible mode in the event specified in paragraphs 6.13. to 6.15.
In case of optical warning, the tell-tale shall, when illuminated, be sufficiently bright to be visible to the driver under both daylight and night-time driving conditions, when the driver has adapted to the ambient roadway light conditions.
This tell-tale shall be activated as a check of lamp function either when the propulsion system is turned to the "On" position, or when the propulsion system is in a position between "On" and "Start" that is designated by the manufacturer as a check position. This requirement does not apply to the tell-tale or text shown in a common space.
- 5.2.4. Warning in the event of low energy content of REESS.
For pure electric vehicles (vehicles equipped with a powertrain containing exclusively electric machines as propulsion energy converters and exclusively rechargeable electric energy storage systems as propulsion energy storage systems), a warning to the driver in the event of low REESS state of charge shall be provided. Based on engineering judgment, the manufacturer shall determine the necessary level of REESS energy remaining, when the driver warning is first provided.
In case of optical warning, the tell-tale shall, when illuminated, be sufficiently bright to be visible to the driver under both daylight and night-time driving conditions, when the driver has adapted to the ambient roadway light conditions.
- 5.3. Preventing accidental or unintended vehicle movement
- 5.3.1. At least a momentary indication shall be given to the driver each time when the vehicle is first placed in "active driving possible mode" after manual activation of the propulsion system.
However, this provision is optional under conditions where an internal combustion engine provides directly or indirectly the vehicle's propulsion power upon start up.
- 5.3.2. When leaving the vehicle, the driver shall be informed by a signal (e.g. optical or audible signal) if the vehicle is still in the active driving possible mode. Moreover, in case of vehicles of category M₂ and M₃ with a capacity of more than 22 passengers in addition to the driver, this signal shall already be given when the drivers leave their seat.
However, this provision is optional under conditions where an internal combustion engine provides, directly or indirectly, the vehicle's propulsion power while leaving the vehicle or driver seat.
- 5.3.3. If the REESS can be externally charged, vehicle movement by its own propulsion system shall be impossible as long as the vehicle connector is physically connected to the vehicle inlet.
This requirement shall be demonstrated by using the vehicle connector specified by the vehicle manufacturer.

The above requirements are only applicable for vehicles when charging from a stationary charging point, with a charging cable of finite length, through a vehicle coupler comprising a vehicle connector and a vehicle inlet.

- 5.3.4. The state of the drive direction control unit shall be identified to the driver.
- 5.4. Determination of hydrogen emissions
 - 5.4.1. This test shall be carried out on all vehicles equipped with open type traction batteries. If the REESS has been approved under Part II of this Regulation and installed in accordance with paragraph 5.2.1.1. this test can be omitted for the approval of the vehicle.
 - 5.4.2. The test shall be conducted following the method described in Annex 8 to the present Regulation. The hydrogen sampling and analysis shall be the ones prescribed. Other analysis methods can be approved if it is proven that they give equivalent results.
 - 5.4.3. During a normal charge procedure in the conditions given in Annex 8, hydrogen emissions shall be below 125 g during 5 h, or below $25 \times t_2$ g during t_2 (in h).
 - 5.4.4. During a charge carried out by a charger presenting a failure (conditions given in Annex 8), hydrogen emissions shall be below 42 g. Furthermore the charger shall limit this possible failure to 30 minutes.
 - 5.4.5. All the operations linked to the REESS charging shall be controlled automatically, included the stop for charging.
 - 5.4.6. It shall not be possible to take a manual control of the charging phases.
 - 5.4.7. Normal operations of connection and disconnection to the mains or power cuts shall not affect the control system of the charging phases.
 - 5.4.8. Important charging failures shall be permanently indicated. An important failure is a failure that can lead to a malfunction of the charger during charging later on.
 - 5.4.9. The manufacturer has to indicate in the owner's manual, the conformity of the vehicle to these requirements.
 - 5.4.10. The approval granted to a vehicle type relative to hydrogen emissions can be extended to different vehicle types belonging to the same family, in accordance with the definition of the family given in Annex 8, Appendix 2.

6. Part II: Requirements of a Rechargeable Electrical Energy Storage System (REESS) with regard to its safety

- 6.1. General

The procedures prescribed in Annex 9 of this Regulation shall be applied.
- 6.2. Vibration
 - 6.2.1. The test shall be conducted in accordance with Annex 9A to this Regulation.
 - 6.2.2. Acceptance criteria
 - 6.2.2.1. During the test, there shall be no evidence of:
 - (a) Electrolyte leakage;
 - (b) Rupture (applicable to high voltage REESS (s) only);
 - (c) Venting (for REESS other than open-type traction battery);
 - (d) Fire;

(e) Explosion.

The evidence of electrolyte leakage shall be verified by visual inspection without disassembling any part of the Tested-Device. An appropriate technique shall, if necessary, be used in order to confirm if there is any electrolyte leakage from the REESS resulting from the test. The evidence of venting shall be verified by visual inspection without disassembling any part of the Tested-Device.

6.2.2.2. For a high voltage REESS, the isolation resistance measured after the test in accordance with Annex 5B to this Regulation shall not be less than 100 Ω /Volt.

6.3. Thermal shock and cycling

6.3.1. This test shall be conducted in accordance with Annex 9B to this Regulation.

6.3.2. Acceptance criteria

6.3.2.1. During the test, there shall be no evidence of:

- (a) Electrolyte leakage;
- (b) Rupture (applicable to high voltage REESS (s) only);
- (c) Venting (for REESS other than open-type traction battery);
- (d) Fire;
- (e) Explosion.

The evidence of electrolyte leakage shall be verified by visual inspection without disassembling any part of the Tested-Device. An appropriate technique shall, if necessary, be used in order to confirm if there is any electrolyte leakage from the REESS resulting from the test. The evidence of venting shall be verified by visual inspection without disassembling any part of the Tested-Device.

6.3.2.2. For a high voltage REESS, the isolation resistance measured after the test in accordance with Annex 5B to this Regulation shall not be less than 100 Ω /Volt.

6.4. Mechanical impact

6.4.1. Mechanical Shock

At the manufacturer's choice the test may be performed as, either

- (a) Vehicle based tests in accordance with paragraph 6.4.1.1. of this Regulation, or
- (b) Component based tests in accordance with paragraph 6.4.1.2. of this Regulation, or
- (c) Any combination of (a) and (b) above, for different direction of vehicle travel.

6.4.1.1. Vehicle based test

Compliance with the requirements of the acceptance criteria of paragraph 6.4.1.3. below may be demonstrated by REESS(s) installed in vehicles that have been subjected to vehicle crash tests in accordance with UN Regulation No. 94, Annex 3 or UN Regulation No. 137, Annex 3 for frontal impact, and UN Regulation No. 95, Annex 4 for side impact. The ambient temperature and the SOC shall be in accordance with the said Regulations. This requirement is deemed to be met if the vehicle equipped with electric power train operating on high voltage is approved in accordance with UN Regulation No. 94 (04 series of amendments or later) or UN

Regulation No. 137 (01 series of amendments or later) for frontal impact and UN Regulation No. 95 (05 series of amendments or later) for lateral impact.

The approval of a REESS tested under this paragraph shall be limited to the specific vehicle type.

6.4.1.2. Component based test

The test shall be conducted in accordance with Annex 9C to this Regulation.

6.4.1.3. Acceptance criteria

During the test there shall be no evidence of:

- (a) Fire;
- (b) Explosion;
- (c1) Electrolyte leakage if tested according to paragraph 6.4.1.1.:

(i) In case of aqueous electrolyte REESS:

For a period from the impact until 60 minutes after the impact, there shall be no electrolyte leakage from the REESS into the passenger compartment and

no more than 7 per cent by volume of the REESS electrolyte with a maximum of 5.0 l leaked from the REESS to the outside of the passenger compartment. The leaked amount of electrolyte can be measured by the usual techniques of determination of liquid volumes after its collection. For containers containing Stoddard, coloured coolant and electrolyte, the fluids shall be allowed to separate by specific gravity then measured;

(ii) In case of non-aqueous electrolyte REESS:

For a period from the impact until 60 minutes after the impact, there shall be no liquid electrolyte leakage from the REESS into the passenger compartment, luggage compartment and no liquid electrolyte leakage to outside the vehicle. This requirement shall be verified by visual inspection without disassembling any part of the vehicle.

(c2) Electrolyte leakage if tested according to paragraph 6.4.1.2.

After the vehicle based test (paragraph 6.4.1.1.), REESS shall remain attached to the vehicle by at least one component anchorage, bracket, or any structure that transfers loads from REESS to the vehicle structure, and REESS located outside the passenger compartment shall not enter the passenger compartment.

After the component based test (paragraph 6.4.1.2.) the Tested-Device shall be retained by its mounting and its components shall remain inside its boundaries.

For a high voltage REESS the isolation resistance of the Tested-Device shall ensure at least 100 Ω /Volt for the whole REESS measured after the test in accordance with Annex 5A or Annex 5B to this Regulation, or the protection degree IPXXB shall be fulfilled for the Tested-Device.

For a REESS tested in accordance with paragraph 6.4.1.2., the evidence of electrolyte leakage shall be verified by visual inspection without disassembling any part of the Tested-Device.

6.4.2. Mechanical integrity

This test applies only to a REESS intended for installation in vehicles of categories M₁ and N₁.

At the manufacturer's choice, the test may be performed as, either:

- (a) Vehicle based tests in accordance with paragraph 6.4.2.1. of this Regulation, or
- (b) Component based tests in accordance with paragraph 6.4.2.2. of this Regulation.

6.4.2.1. Vehicle specific test

At the manufacturer's choice, the test may be performed as either:

- (a) A vehicle based dynamic tests in accordance with paragraph 6.4.2.1.1. of this Regulation, or
- (b) A vehicle specific component test in accordance with paragraph 6.4.2.1.2. of this Regulation, or
- (c) Any combination of (a) and (b) above, for different directions of vehicle travel.

When the REESS is mounted in a position which is between a line from the rear edge of the vehicle perpendicular to the centre line of the vehicle and 300 mm forward and parallel to this line, the manufacturer shall demonstrate the mechanical integrity performance of the REESS in the vehicle to the Technical Service.

The approval of a REESS tested under this paragraph shall be limited to specific vehicle type.

6.4.2.1.1. Vehicle based dynamic test

Compliance with the requirements of the acceptance criteria of paragraph 6.4.2.3. below may be demonstrated by REESS(s) installed in vehicles that have been subjected to a vehicle crash test in accordance with the Annex 3 to UN Regulations Nos. 94 or 137 for frontal impact, and Annex 4 to Regulation No. 95 for side impact. The ambient temperature and the SOC shall be in accordance with the said Regulations. This requirement is deemed to be met if the vehicle equipped with the electric power train operating on high voltage is approved in accordance with UN Regulation No. 94 (04 series of amendments or later) or UN Regulation No. 137 (01 series of amendments or later) for frontal impact and UN Regulation No. 95 (05 series of amendments or later) for lateral impact.

6.4.2.1.2. Vehicle specific component test

The test shall be conducted in accordance with Annex 9D of this Regulation.

The crush force specified in paragraph 3.2.1. of Annex 9D may be replaced with the value declared by the vehicle manufacturer using the data obtained from either actual crash tests or its simulation as specified in Annex 3 of UN Regulations Nos. 94 or 137 in the direction of travel and according to Annex 4 to UN Regulation No. 95 in the direction

horizontally perpendicular to the direction of travel. These forces shall be agreed by the Technical Service.

The manufacturers may, in agreement with the Technical Services, use forces derived from the data obtained from alternative crash test procedures, but these forces shall be equal to or greater than the forces that would result from using data in accordance with the Regulations specified above.

The manufacturer may define the relevant parts of the vehicle structure used for the mechanical protection of the REESS components. The test shall be conducted with the REESS mounted to this vehicle structure in a way which is representative of its mounting in the vehicle.

6.4.2.2. Component based test

The test shall be conducted in accordance with Annex 9D to this Regulation.

REESS approved according to this paragraph shall be mounted in a position which is between the two planes; (a) a vertical plane perpendicular to the centre line of the vehicle located 420 mm rearward from the front edge of the vehicle, and (b) a vertical plane perpendicular to the centre line of the vehicle located 300 mm forward from the rear edge of the vehicle.

The mounting restrictions shall be documented in Annex 1 – Appendix 2.

The crush force specified in paragraph 3.2.1. of Annex 9D may be replaced with the value declared by the manufacturer, where the crush force shall be documented in Annex 1, Appendix 2 as a mounting restriction. In this case, the vehicle manufacturer who uses such REESS shall demonstrate, during the process of approval for Part I of this Regulation, that the contact force to the REESS will not exceed the figure declared by the REESS manufacturer. Such force shall be determined by the vehicle manufacturer using the data obtained from either actual crash test or its simulation as specified in Annex 3 to UN Regulations Nos. 94 or 137 in the direction of travel and according to Annex 4 to Regulation No. 95 in the direction horizontally perpendicular to the direction of travel. These forces shall be agreed by the manufacturer together with the Technical Service.

The manufacturers may, in agreement with the Technical Services, use forces derived from the data obtained from alternative crash test procedures, but these forces shall be equal to or greater than the forces that would result from using data in accordance with the regulations specified above.

6.4.2.3. Acceptance criteria

During the test there shall be no evidence of:

- (a) Fire;
- (b) Explosion;
- (c1) Electrolyte leakage if tested according to paragraph 6.4.1.1.:

- (i) In case of aqueous electrolyte REESS:

For a period from the impact until 60 minutes after the impact there shall be no electrolyte leakage from the REESS into the passenger compartment and

no more than 7 per cent by volume of the REESS electrolyte with a maximum of 5.0 l leaked from the REESS to the outside of the passenger compartment. The leaked amount of electrolyte can be measured by the usual techniques of determination of liquid volumes after its collection. For containers containing stoddard, coloured coolant and electrolyte, the fluids shall be allowed to separate by specific gravity then measured.

- (ii) In case of non-aqueous electrolyte REESS:

For a period from the impact until 60 minutes after the impact, there shall be no liquid electrolyte leakage from the REESS into the passenger compartment, luggage compartment and no liquid electrolyte leakage to outside the vehicle. This requirement shall be verified by visual inspection without disassembling any part of the vehicle.

- (c2) Electrolyte leakage if tested according to paragraph 6.4.2.2.

For a high voltage REESS, the isolation resistance of the Tested-Device shall ensure at least 100 Ω /Volt for the whole REESS measured in accordance with

Annex 5A or Annex 5B of this Regulation or the protection degree IPXXB shall be fulfilled for the Tested-Device.

If tested according to paragraph 6.4.2.2., the evidence of electrolyte leakage shall be verified by visual inspection without disassembling any part of the Tested-Device.

6.5. Fire resistance

This test is required for REESS containing flammable electrolyte.

This test is not required when the REESS as installed in the vehicle, is mounted such that the lowest surface of the casing of the REESS is more than 1.5m above the ground. At the option of the manufacturer, this test may be performed where the of the REESS's lower surface is higher than 1.5 m above the ground. The test shall be carried out on one test sample.

At the manufacturer's choice the test may be performed as, either:

- (a) A vehicle based test in accordance with paragraph 6.5.1. of this Regulation, or
- (b) A component based test in accordance with paragraph 6.5.2. of this Regulation.

6.5.1. Vehicle based test

The test shall be conducted in accordance with Annex 9E paragraph 3.2.1. of this Regulation.

The approval of a REESS tested according to this paragraph shall be limited to approvals for a specific vehicle type.

6.5.2. Component based test

The test shall be conducted in accordance with Annex 9E paragraph 3.2.2. of this Regulation.

6.5.3. Acceptance criteria

6.5.3.1. During the test, the Tested-Device shall exhibit no evidence of explosion.

6.6. External short circuit protection

6.6.1. The test shall be conducted in accordance with Annex 9F of this Regulation.

6.6.2. Acceptance criteria;

6.6.2.1. During the test there shall be no evidence of:

- (a) Electrolyte leakage;
- (b) Rupture (applicable to high voltage REESS(s) only);
- (c) Venting (for REESS other than open-type traction battery);
- (d) Fire;
- (e) Explosion.

The evidence of electrolyte leakage shall be verified by visual inspection without disassembling any part of the Tested-Device. An appropriate technique shall, if necessary, be used in order to confirm if there is any electrolyte leakage from the REESS resulting from the test. The evidence of venting shall be verified by visual inspection without disassembling any part of the Tested-Device.

6.6.2.2. For a high voltage REESS, the isolation resistance measured after the test in accordance with Annex 5 B to this Regulation shall not be less than 100 Ω /Volt.

6.7. Overcharge protection

6.7.1. The test shall be conducted in accordance with Annex 9G to this Regulation.

6.7.2. Acceptance criteria

6.7.2.1. During the test there shall be no evidence of:

- (a) Electrolyte leakage;
- (b) Rupture (applicable to high voltage REESS(s) only);
- (c) Venting (for REESS other than open-type traction battery);
- (d) Fire;
- (~~e~~) Explosion.

The evidence of electrolyte leakage shall be verified by visual inspection without disassembling any part of the Tested-Device. An appropriate technique shall, if necessary, be used in order to confirm if there is any electrolyte leakage from the REESS resulting from the test. The evidence of venting shall be verified by visual inspection without disassembling any part of the Tested-Device.

6.7.2.2. For a high voltage REESS, the isolation resistance measured after the test in accordance with Annex 5B to this Regulation shall not be less than 100 Ω /Volt.

6.8. Over-discharge protection

6.8.1. The test shall be conducted in accordance with Annex 9H to this Regulation.

6.8.2. Acceptance criteria

6.8.2.1. During the test there shall be no evidence of:

- (a) Electrolyte leakage;
- (b) Rupture (applicable to high voltage REESS(s) only);
- (c) Venting (for REESS other than open-type traction battery);
- (d) Fire;
- (e) Explosion.

The evidence of electrolyte leakage shall be verified by visual inspection without disassembling any part of the Tested-Device. An appropriate technique shall, if necessary, be used in order to confirm if there is any electrolyte leakage from the REESS resulting from the test. The evidence of venting shall be verified by visual inspection without disassembling any part of the Tested-Device.

6.8.2.2. For a high voltage REESS the isolation resistance measured after the test in accordance with Annex 5B to this Regulation shall not be less than 100 Ω /Volt.

6.9. Over-temperature protection

6.9.1. The test shall be conducted in accordance with Annex 9I to this Regulation.

6.9.2. Acceptance criteria

6.9.2.1. During the test there shall be no evidence of:

- (a) Electrolyte leakage;
- (b) Rupture (applicable to high voltage REESS(s) only);
- (c) Venting (for REESS other than open-type traction battery);
- (d) Fire;
- (e) Explosion.

The evidence of electrolyte leakage shall be verified by visual inspection without disassembling any part of the Tested-Device. An appropriate technique shall, if necessary, be used in order to confirm if there is any electrolyte leakage from the REESS resulting from the test. The evidence of venting shall be verified by visual inspection without disassembling any part of the Tested-Device.

6.9.2.2. For a high voltage REESS, the isolation resistance measured after the test in accordance with Annex 5B to this Regulation shall not be less than 100 Ω /Volt.

6.10. Overcurrent protection

This test is required for REESS intended for use on vehicles of categories M1 and N1 that have the capability of charging by DC external electricity supply.

6.10.1. The test shall be conducted in accordance with Annex 9J to this Regulation.

6.10.2. Acceptance criteria

6.10.2.1. During the test there shall be no evidence of:

- (a) Electrolyte leakage;
- (b) Rupture (applicable to high voltage REESS(s) only);
- (c) Venting (for REESS other than open-type traction battery);
- (d) Fire;
- (e) Explosion.

The evidence of electrolyte leakage shall be verified by visual inspection without disassembling any part of the Tested-Device. An appropriate technique shall, if necessary, be used in order to confirm if there is any electrolyte leakage from the REESS resulting from the test. The evidence of venting shall be verified by visual inspection without disassembling any part of the Tested-Device.

6.10.2.2. The overcurrent protection control of the REESS shall terminate charging or the temperature measured on the casing of the REESS shall be stabilized, such that the temperature gradient varies by less than 4 °C through 2 hours after the maximum overcurrent charging level is reached.

6.10.2.3. For a high voltage REESS, the isolation resistance measured after the test in accordance with Annex 5B to this Regulation shall not be less than 100 Ω /V.

6.11. Low-temperature protection.

REESS manufacturer must make available, at the request of the Technical Service with its necessity, the following documentations explaining safety performance of the system level or subsystem level of the vehicle to demonstrate that the REESS monitors and appropriately controls REESS operations at low temperatures at the safety boundary limits of the REESS:

- (a) A system diagram;
- (b) Written explanation on the lower boundary temperature for safe operation of REESS;
- (c) Method of detecting REESS temperature;
- (d) Action taken when the REESS temperature is at or lower than the lower boundary for safe operation of the REESS.

6.12. Management of gases emitted from REESS

6.12.1. Under vehicle operation including the operation with a failure, the vehicle occupants shall not be exposed to any hazardous environment caused by emissions from REESS.

- 6.12.2. Open-type traction batteries shall meet the requirements of paragraph 5.4. of this Regulation with regard to hydrogen emissions.
- 6.12.3. For REESS other than open-type traction battery, the requirement of paragraph 6.12.1. is deemed to be satisfied, if all applicable requirements of the following tests are met: paragraph 6.2. (vibration), paragraph 6.3. (thermal shock and cycling), paragraph 6.6. (external short circuit protection), paragraph 6.7. (overcharge protection), paragraph 6.8. (over-discharge protection), paragraph 6.9. (over-temperature protection) and paragraph 6.10. (overcurrent protection).
- 6.13. Warning in the event of operational failure of vehicle controls that manage REESS safe operation.
- The REESS or vehicle system shall provide a signal to activate the warning specified in paragraph 5.2.3. in the event of operational failure of the vehicle controls (e.g. input and output signals to the management system of REESS, sensors within REESS, etc.) that manage the safe operation of the REESS. REESS or vehicle manufacturer shall make available, at the request of the Technical Service with its necessity, the following documentation explaining safety performance of the system level or subsystem level of the vehicle:
- 6.13.1. A system diagram that identifies all the vehicle controls that manage REESS operations. The diagram must identify what components are used to generate a warning due to operational failure of vehicle controls to conduct one or more basic operations.
- 6.13.2. A written explanation describing the basic operation of the vehicle controls that manage REESS operation. The explanation must identify the components of the vehicle control system, provide description of their functions and capability to manage the REESS, and provide a logic diagram and description of conditions that would lead to triggering of the warning.
- 6.14. Warning in the case of a thermal event within the REESS.
- The REESS or vehicle system shall provide a signal to activate the warning specified in paragraph 5.2.3. in the case of a thermal event in the REESS (as specified by the manufacturer). REESS or vehicle manufacturer shall make available, at the request of the Technical Service with its necessity, the following documentation explaining safety performance of the system level or subsystem level of the vehicle:
- 6.14.1. The parameters and associated threshold levels that are used to indicate a thermal event (e.g. temperature, temperature rise rate, SOC level, voltage drop, electrical current, etc.) to trigger the warning.
- 6.14.2. A system diagram and written explanation describing the sensors and operation of the vehicle controls to manage the REESS in the event of a thermal event.
- 6.15. Thermal propagation.
- For a REESS containing flammable electrolyte, the vehicle occupants shall not be exposed to any hazardous environment caused by thermal propagation which is triggered by an internal short circuit leading to a single cell thermal runaway. To ensure this, the requirements of paragraphs 6.15.1. and 6.15.2. shall be satisfied.⁴

⁴ The manufacturer will be accountable for the verity and integrity of documentation submitted, and assume full responsibility for the safety of occupants against adverse effects arising from thermal propagation caused by internal short circuit.

- 6.15.1. The REESS or vehicle system shall provide a signal to activate the advance warning indication in the vehicle to allow egress or 5 minutes prior to the presence of a hazardous situation inside the passenger compartment caused by thermal propagation which is triggered by an internal short circuit leading to a single cell thermal runaway such as fire, explosion or smoke. This requirement is deemed to be satisfied if the thermal propagation does not lead to a hazardous situation for the vehicle occupants. REESS or vehicle manufacturer shall make available, at the request of the Technical Service with its necessity, the following documentation explaining safety performance of the system level or sub-system level of the vehicle:
 - 6.15.1.1. The parameters (for example, temperature, voltage or electrical current) which trigger the warning indication.
 - 6.15.1.2. Description of the warning system.
- 6.15.2. The REESS or vehicle system shall have functions or characteristics in the cell or REESS intended to protect vehicle occupants (as described in paragraph 6.15.) in conditions caused by thermal propagation which is triggered by an internal short circuit leading to a single cell thermal runaway. REESS or vehicle manufacturers shall make available, at the request of the Technical Service with its necessity, the following documentation explaining safety performance of the system level or sub-system level of the vehicle:
 - 6.15.2.1. A risk reduction analysis using appropriate industry standard methodology (for example, IEC 61508, MIL-STD 882E, ISO 26262, AIAG DFMEA, fault analysis as in SAE J2929, or similar), which documents the risk to vehicle occupants caused by thermal propagation which is triggered by an internal short circuit leading to a single cell thermal runaway and documents the reduction of risk resulting from implementation of the identified risk mitigation functions or characteristics.
 - 6.15.2.2. A system diagram of all relevant physical systems and components. Relevant systems and components are those which contribute to protection of vehicle occupants from hazardous effects caused by thermal propagation triggered by a single cell thermal runaway.
 - 6.15.2.3. A diagram showing the functional operation of the relevant systems and components, identifying all risk mitigation functions or characteristics.
 - 6.15.2.4. For each identified risk mitigation function or characteristic:
 - 6.15.2.4.1. A description of its operation strategy;
 - 6.15.2.4.2. Identification of the physical system or component which implements the function;
 - 6.15.2.4.3. One or more of the following engineering documents relevant to the manufacturers design which demonstrates the effectiveness of the risk mitigation function:
 - (a) Tests performed including procedure used and conditions and resulting data;
 - (b) Analysis or validated simulation methodology and resulting data.

7. Modifications and extension of the type approval

- 7.1. Every modification of the vehicle or REESS type with regard to this Regulation shall be notified to the Type Approval Authority which approved the vehicle or REESS type. The Authority may then either:
 - (a) Decide, in consultation with the manufacturer, that a new type approval is to be granted; or

- (b) Apply the procedure contained in paragraph 7.1.1. (Revision) and, if applicable, the procedure contained in paragraph 7.1.2. (Extension).

7.1.1. Revision

When details recorded in the information documents of Annex 1 - Appendix 1 or Annex 1 - Appendix 2 have changed and the Type Approval Authority considers that the modifications made are unlikely to have appreciable adverse effect, and that in any case the vehicle still meets the requirements, the modification shall be designated a "revision".

In such a case, the Type Approval Authority shall issue the revised pages of the information documents of Annex 1 – Appendix 1 or Annex 1 – Appendix 2 as necessary, marking each revised page to show clearly the nature of the modification and the date of reissue. A consolidated, updated version of the information documents of Annex 1 – Appendix 1 or Annex 1 – Appendix 2, accompanied by a detailed description of the modification, shall be deemed to meet this requirement.

7.1.2. Extension

The modification shall be designated an "extension" if, in addition to the change of the particulars recorded in the information folder:

- (a) Further inspections or tests are required; or
- (b) Any information on the communication document (with the exception of its attachments) has changed; or
- (c) Approval to a later series of amendments is requested after its entry into force.

8. Conformity of production

The conformity of production procedure shall comply with the requirements set out in Schedule 1 of the Agreement (E/ECE/TRANS/505/Rev.3).

- 8.1. Vehicles or REESS approved under this Regulation shall be so manufactured as to conform to the type approved by meeting the requirements of the relevant part(s) of this Regulation.
- 8.2. In order to verify that the requirements of paragraph 8.1. are met, appropriate production checks shall be carried out.

9. Penalties for non-conformity of production

- 9.1. The approval granted in respect of a vehicle/REESS type, pursuant to this Regulation may be withdrawn if the requirements laid down in paragraph 8. above are not complied with.
- 9.2. If a Contracting Party to the Agreement applying this Regulation withdraws an approval it has previously granted, it shall forthwith so notify the other Contracting Parties applying this Regulation, by means of a copy of the approval form bearing at the end, in large letters, the signed and dated annotation "APPROVAL WITHDRAWN".

10. Production definitively discontinued

If the holder of the approval completely ceases to manufacture a vehicle/REESS type approved in accordance with this Regulation, he shall so inform the Type Approval Authority which granted the approval. Upon receiving the relevant communication, that Type Approval Authority shall

inform thereof the other Contracting Parties to the Agreement applying this Regulation by means of a copy of the approval form bearing at the end, in large letters, the signed and dated annotation "PRODUCTION DISCONTINUED".

11. Names and addresses of Technical Services responsible for conducting approval tests and of Type Approval Authorities

The Contracting Parties to the 1958 Agreement applying this Regulation shall communicate to the United Nations Secretariat the names and addresses of the Technical Services responsible for conducting approval tests and the Type Approval Authorities which grant approval and to which forms certifying approval or extension or refusal or withdrawal of approval or production definitively discontinued, issued in other countries are to be sent.

12. Transitional provisions

- 12.1. As from the official date of entry into force of the 03 series of amendments, no Contracting Party applying this Regulation shall refuse to grant or refuse to accept type approvals under this Regulation as amended by the 03 series of amendments.
- 12.2. As from 1 September 2023, Contracting Parties applying this Regulation shall not be obliged to accept type approvals to the preceding series of amendments, first issued after 1 September 2023.
- 12.3. Until 1 September 2025, Contracting Parties applying this Regulation shall accept type approvals to the preceding series of amendments, first issued before 1 September 2023.
- 12.4. As from 1 September 2025, Contracting Parties applying this Regulation shall not be obliged to accept type approvals issued to the preceding series of amendments to this Regulation.
- 12.5. Contracting Parties applying this Regulation shall not refuse to grant type approvals according to any preceding series of amendments to this Regulation or extensions thereof.
- 12.6. Notwithstanding the transitional provisions above, Contracting Parties who start to apply this Regulation after the date of entry into force of the most recent series of amendments are not obliged to accept type approvals which were granted in accordance with any of the preceding series of amendments to this Regulation.

8. Technical Service responsible for conducting approval tests:
.....
9. Date of report issued by that Service:
10. Number of report issued by that Service:
11. Location of the approval mark:
12. Reason(s) for extension of approval (if applicable)²:
13. Approval granted/extended/refused/withdrawn²:
14. Place:
15. Date:
16. Signature:
17. The documents filed with the request for approval or extension may be obtained on request.

Annex 1 – Part 2

Communication

(Maximum format: A4 (210 x 297 mm))

issued by: Name of administration:

.....

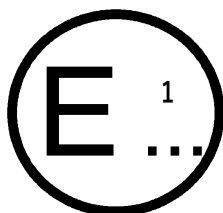

Concerning:² Approval granted
 Approval extended
 Approval refused
 Approval withdrawn
 Production definitively discontinued

of a REESS type as component/separate technical unit² pursuant to Regulation No. 100

Approval No. Extension No.

1. Trade name or mark of the REESS:
2. Type of REESS:
3. Manufacturer's name and address:
4. If applicable, name and address of manufacturer's representative:
5. Description of the REESS:
6. Installation restrictions applicable to the REESS as described in paragraphs 6.4 and 6.5:
7. REESS submitted for approval on:
8. Technical Service responsible for conducting approval tests:
9. Date of report issued by that Service:
10. Number of report issued by that Service:
11. Location of the approval mark:
12. Reason(s) for extension of approval (if applicable)²:
13. Approval granted/extended/refused/withdrawn²:
14. Place:
15. Date:
16. Signature:

¹ Distinguishing number of the country which has granted/extended/refused/withdrawn approval (see approval provisions in the Regulation).

² Strike out what does not apply.

17. The documents filed with the request for approval or extension may be obtained on request.

Annex 1 – Appendix 1

Essential characteristics of road vehicles or systems

1. General
 - 1.1. Make (trade name of manufacturer):
 - 1.2. Type:
 - 1.3. Vehicle category:
 - 1.4. Commercial name(s) if available:
.....
 - 1.5. Manufacturer's name and address:
.....
 - 1.6. If applicable, name and address of manufacturer's representative:
 - 1.7. Drawing and/or photograph of the vehicle:.....
 - 1.8. Approval number of the REESS:
2. Electric motor (traction motor)
 - 2.1. Type (winding, excitation):
 - 2.2. Maximum net power and / or maximum 30 minutes power (kW):
3. REESS
 - 3.1. Trade name and mark of the REESS:
 - 3.2. Indication of all types of cells:
 - 3.2.1. The cell chemistry:.....
 - 3.2.2. Physical dimensions:.....
 - 3.2.3. Capacity of the cell (Ah):.....
 - 3.3. Description or drawing(s) or picture(s) of the REESS explaining:
 - 3.3.1. Structure:.....
 - 3.3.2. Configuration (number of cells, mode of connection, etc.):
 - 3.3.3. Dimensions:
 - 3.3.4. Casing (construction, materials and physical dimensions):
 - 3.4. Electrical specification:.....
 - 3.4.1. Nominal voltage (V):

- 3.4.2. Working voltage (V):
- 3.4.3. Capacity (Ah):
- 3.4.4. Maximum current (A):
- 3.5. Gas combination rate (in per cent):
- 3.6. Description or drawing(s) or picture(s) of the installation of the REESS in the vehicle:
- 3.6.1. Physical support:
- 3.7. Type of thermal management
- 3.8. Electronic control:
- 4. Fuel Cell (if any)
- 4.1. Trade name and mark of the fuel cell:
-
- 4.2. Types of fuel cell:
- 4.3. Nominal voltage (V):
- 4.4. Number of cells:
- 4.5. Type of cooling system (if any):
- 4.6. Max Power(kW):
- 5. Fuse and/or circuit breaker
- 5.1. Type:
- 5.2. Diagram showing the functional range:
- 6. Power wiring harness
- 6.1. Type:
- 7. Protection against Electric Shock
- 7.1. Description of the protection concept:
- 8. Additional data
- 8.1. Brief description of the power circuit components installation or drawings/ pictures showing the location of the power circuit components installation:
- 8.2. Schematic diagram of all electrical functions included in power circuit:
- 8.3. Working voltage (V):

Annex 1 - Appendix 2

Essential characteristics of REESS

1. REESS
- 1.1. Trade name and mark of the REESS:
- 1.1.1. Type of REESS.....
- 1.2. Indication of all types of cells:.....
- 1.2.1. The cell chemistry:
- 1.2.2. Physical dimensions:
- 1.2.3. Capacity of the cell (Ah):
- 1.3. Description or drawing(s) or picture(s) of the REESS explaining
 - 1.3.1. Structure:
 - 1.3.2. Configuration (number of cells, mode of connection, etc.):
 - 1.3.3. Dimensions:
 - 1.3.4. Casing (construction, materials and physical dimensions):
- 1.4. Electrical specification
 - 1.4.1. Nominal voltage (V):.....
 - 1.4.2. Working voltage (V):.....
 - 1.4.3. Capacity (Ah):
 - 1.4.4. Maximum current (A):.....
- 1.5. Gas combination rate (in percentage):
- 1.6. Description or drawing(s) or picture(s) of the installation of the REESS in the vehicle:
- 1.6.1. Physical support:.....
- 1.7. Type of thermal management:
- 1.8. Electronic control:
- 1.9. Category of vehicles on which the REESS can be installed:

Annex 2

Arrangements of the approval marks

Model A
 (See paragraph 4.4. of this Regulation)

Figure 1

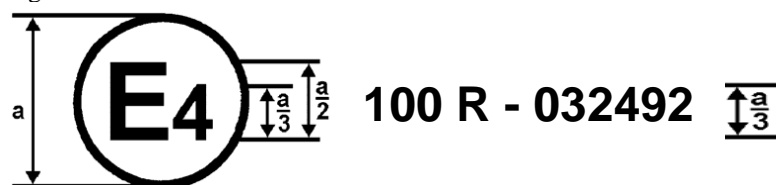

$a = 8 \text{ mm min.}$

The approval mark in Figure 1 affixed to a vehicle shows that the road vehicle type concerned has been approved in the Netherlands (E 4), pursuant to Regulation No. 100, and under the approval number 032492. The first two digits of the approval number indicate that the approval was granted in accordance with the requirements of Regulation No. 100 as amended by 03 series of amendments.

Figure 2



$a = 8 \text{ mm min.}$

The approval mark in Figure 2 affixed to a REESS shows that the REESS type ("ES") concerned has been approved in the Netherlands (E 4), pursuant to Regulation No. 100, and under the approval number 032492. The first two digits of the approval number indicate that the approval was granted in accordance with the requirements of Regulation No. 100 as amended by 03 series of amendments.

Model B
 (See paragraph 4.5. of this Regulation)

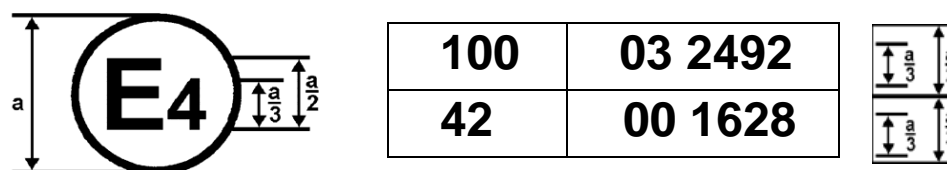

$a = 8 \text{ mm min.}$

The above approval mark affixed to a vehicle shows that the road vehicle concerned has been approved in the Netherlands (E4) pursuant to Regulations Nos. 100 and 42*. The approval number indicates that, at the dates when the respective approvals were granted, Regulation No. 100 was amended by the 03 series of amendments and Regulation No. 42 was still in its original form.

* The latter number is given only as an example.

Annex 3

Protection against direct contacts of parts under voltage

1. Access probes
Access probes to verify the protection of persons against access to live parts are given in Table 1.
2. Test conditions
The access probe is pushed against any openings of the enclosure with the force specified in Table 1. If it partly or fully penetrates, it is placed in every possible position, but in no case shall the stop face fully penetrate through the opening.
Internal barriers are considered part of the enclosure
A low-voltage supply (of not less than 40 V and not more than 50 V) in series with a suitable lamp should be connected, if necessary, between the probe and live parts inside the barrier or enclosure.
The signal-circuit method should also be applied to the moving live parts of high voltage equipment.
Internal moving parts may be operated slowly, where this is possible.
3. Acceptance conditions
The access probe shall not touch live parts.
If this requirement is verified by a signal circuit between the probe and live parts, the lamp shall not light.
In the case of the test for IPXXB, the jointed test finger may penetrate to its 80 mm length, but the stop face (diameter 50 mm x 20 mm) shall not pass through the opening. Starting from the straight position, both joints of the test finger shall be successively bent through an angle of up to 90 degrees with respect to the axis of the adjoining section of the finger and shall be placed in every possible position.
In case of the tests for IPXXD, the access probe may penetrate to its full length, but the stop face shall not fully penetrate through the opening.

Table 1
Access probes for the tests for protection of persons against access to hazardous parts

First numeral	Addit. letter	Access probe (Dimensions in mm)	Test force
2	B	<p style="text-align: center;">Jointed test finger</p>  <p>See Fig. 1 for full dimensions</p> <p>Insulating material</p> <p>Jointed test finger (Metal)</p> <p>Stop face (Ø 50 x 20)</p> <p>Ø 12</p> <p>80</p>	10 N±10%
4, 5, 6	D	<p style="text-align: center;">Test wire 1.0 mm diameter, 100 mm long</p>  <p>Ø 10</p> <p>Approx. 100</p> <p>Handle (Insulating material)</p> <p>Sphere 35±0.2</p> <p>Stop face (Insulating material)</p> <p>Rigid test wire (Metal)</p> <p>100±0.2</p> <p>Edges free from burrs</p> <p>Ø 1 +0.05 / 0</p>	1N±10%

Figure 1
Jointed Test Finger



Material: metal, except where otherwise specified

Linear dimensions in millimeters

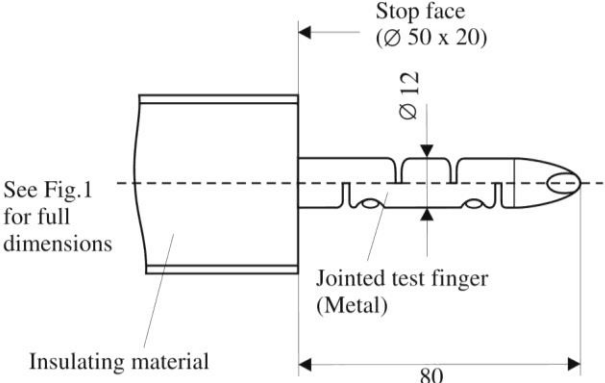
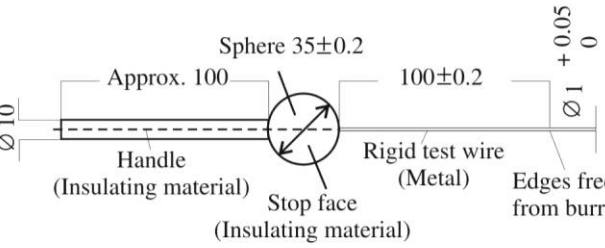
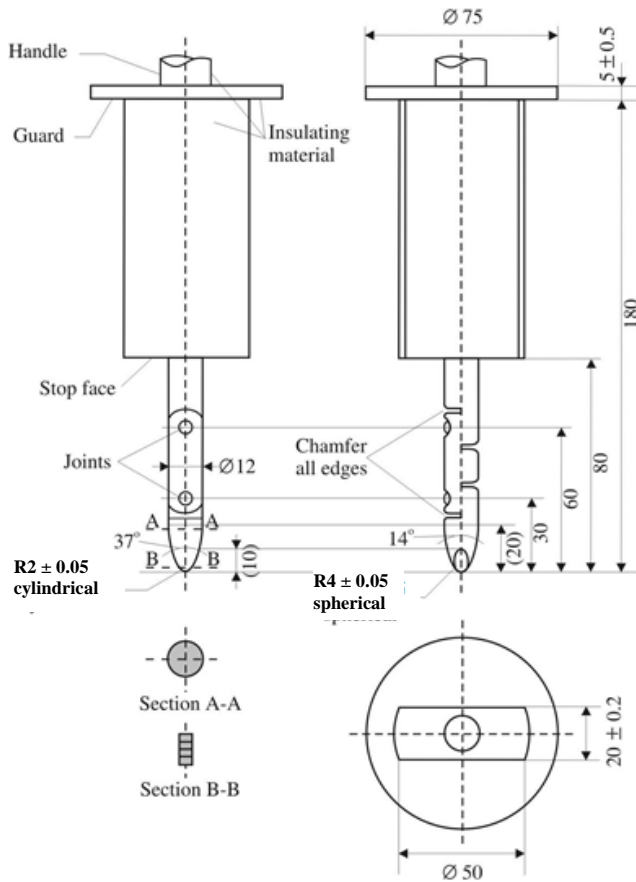
Tolerances on dimensions without specific tolerance:

- (a) On angles: 0/-10 seconds;
- (b) On linear dimensions:
 - (i) up to 25 mm: 0/-0.05 mm;
 - (ii) over 25 mm: ± 0.2 mm.

Both joints shall permit movement in the same plane and the same direction through an angle of 90° with a 0 to $+10^\circ$ tolerance.

Annex 4

Verification of potential equalization

1. Test method using a resistance tester.

The resistance tester is connected to the measuring points (typically, electrical chassis and electro conductive enclosure/electrical protection barrier) and the resistance is measured using a resistance tester that meets the specification that follows:

- (a) Resistance tester: Measurement current at least 0.2 A;
- (b) Resolution: 0.01 Ω or less;
- (c) The resistance R shall be less than 0.1 Ω .

2. Test method using DC power supply, voltmeter and ammeter.

Example of the test method using DC power supply, voltmeter and ammeter is shown below.

Figure 1

Example of Test Method using DC Power Supply

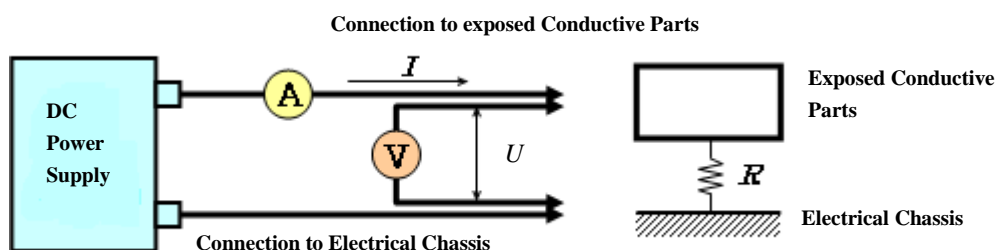

- 2.1. Test Procedure.

The DC power supply, voltmeter and ammeter are connected to the measuring points (Typically, electrical chassis and electro conductive enclosure/electrical protection barrier).

The voltage of the DC power supply is adjusted so that the current flow becomes at least 0.2 A.

The current "I" and the voltage "U" are measured.

The resistance "R" is calculated according to the following formula:

$$R = U / I$$

The resistance R shall be less than 0.1 Ω .

Note: If lead wires are used for voltage and current measurement, each lead wire shall be independently connected to the electrical protection barrier/enclosure/electrical chassis.

Terminal can be common for voltage measurement and current measurement.

Annex 5A

Isolation resistance measurement method for vehicle based tests

1. General

The isolation resistance for each high voltage bus of the vehicle shall be measured or shall be determined by calculation using measurement values from each part or component unit of a high voltage bus (hereinafter referred to as the "divided measurement").

2. Measurement method

The isolation resistance measurement shall be conducted by selecting an appropriate measurement method from among those listed in paragraphs 2.1. through 2.2. of this annex, depending on the electrical charge of the live parts or the isolation resistance, etc.

Megohmmeter or oscilloscope measurements are appropriate alternatives to the procedure described below for measuring isolation resistance. In this case, it may be necessary to deactivate the on-board isolation resistance monitoring system.

The range of the electrical circuit to be measured shall be clarified in advance, using electrical circuit diagrams, etc. If the high voltage buses are conductively isolated from each other, isolation resistance shall be measured for each electrical circuit.

Moreover, modification necessary for measuring the isolation resistance may be carried out, such as removal of the cover in order to reach the live parts, drawing of measurement lines, change in software, etc.

In cases where the measured values are not stable due to the operation of the on-board isolation resistance monitoring system, necessary modification for conducting the measurement may be carried out by stopping of the operation of the device concerned or removing it. Furthermore, when the device is removed, a set of drawings will be used to prove that the isolation resistance between the live parts and the electrical chassis remains unchanged.

These modifications shall not influence the test results.

Utmost care shall be exercised as to short circuit and electric shock since this confirmation might require direct operations of the high-voltage circuit.

2.1. Measurement method using DC voltage from external sources

2.1.1. Measurement instrument

An isolation resistance test instrument capable of applying a DC voltage higher than the working voltage of the high voltage bus shall be used.

2.1.2. Measurement method

An isolation resistance test instrument shall be connected between the live parts and the electrical chassis. Then, the isolation resistance shall be measured by applying a DC voltage at least half of the working voltage of the high voltage bus.

If the system has several voltage ranges (e.g. because of boost converter) in galvanically connected circuit and some of the components cannot withstand the working voltage of the entire circuit, the isolation resistance between those components and the electrical chassis can be measured separately by

applying at least half of their own working voltage with those component disconnected.

- 2.2. Measurement method using the vehicle's own REESS as DC voltage source
 - 2.2.1. Test vehicle conditions

The high voltage-bus shall be energized by the vehicle's own REESS and/or energy conversion system and the voltage level of the REESS and/or energy conversion system throughout the test shall be at least the nominal operating voltage as specified by the vehicle manufacturer.
 - 2.2.2. Measurement instrument

The voltmeter used in this test shall measure DC values and shall have an internal resistance of at least 10 MΩ.
 - 2.2.3. Measurement method
 - 2.2.3.1. First step

The voltage is measured as shown in Figure 1 and the high voltage bus operating voltage (U_b) is recorded. U_b shall be equal to or greater than the nominal operating voltage of the REESS and/or energy conversion system as specified by the vehicle manufacturer.

Figure 1
Measurement of U_b , U_1 , U_2

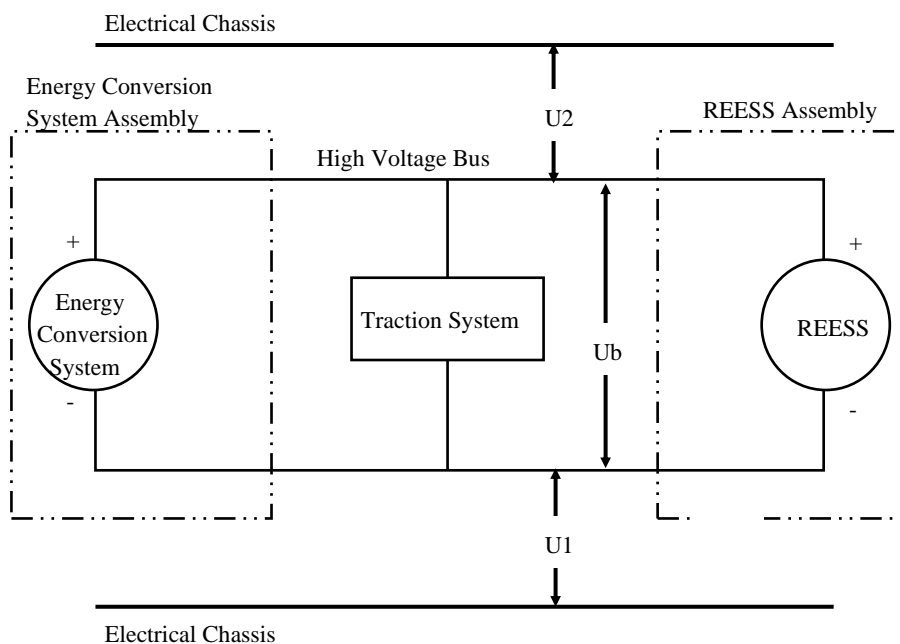

- 2.2.3.2. Second step

Measure and record the voltage (U_1) between the negative side of the high voltage bus and the electrical chassis (see Figure 1).
- 2.2.3.3. Third step

Measure and record the voltage (U_2) between the positive side of the high voltage bus and the electrical chassis (see Figure 1).
- 2.2.3.4. Fourth step

If U_1 is greater than or equal to U_2 , insert a standard known resistance (R_o) between the negative side of the high voltage bus and the electrical chassis. With R_o installed, measure the voltage (U_1') between the negative side of the high voltage bus and the electrical chassis (see Figure 2).

Calculate the electrical isolation (R_i) according to the following formula:

$$R_i = R_o \cdot U_b \cdot (1/U_1' - 1/U_1)$$

Figure 2
Measurement of U_1'

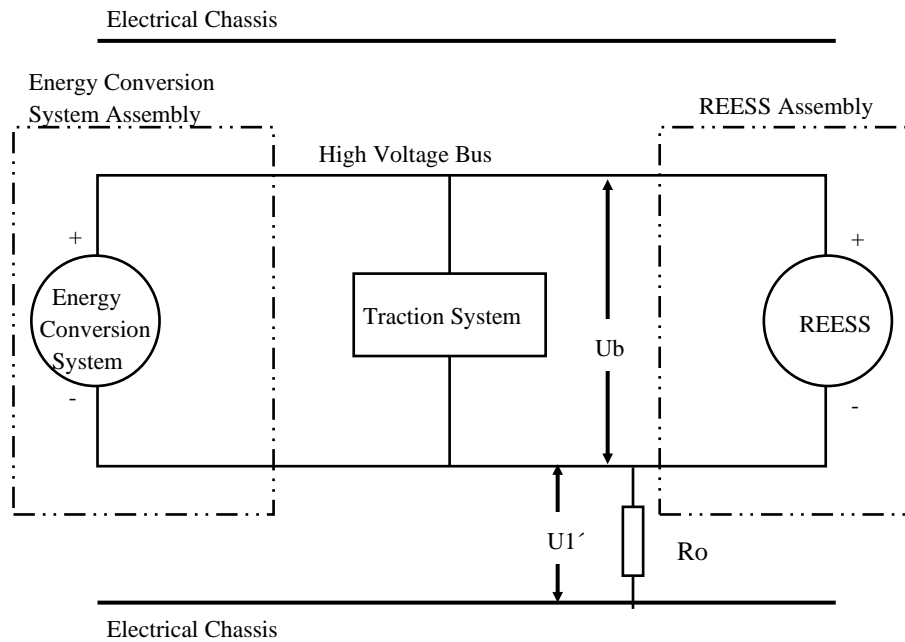

If U_2 is greater than U_1 , insert a standard known resistance (R_o) between the positive side of the high voltage bus and the electrical chassis. With R_o installed, measure the voltage (U_2') between the positive side of the high voltage bus and the electrical chassis (see Figure 3). Calculate the electrical isolation (R_i) according to the formula shown. Divide this electrical isolation value (in Ω) by the nominal operating voltage of the high voltage bus (in volts).

Calculate the electrical isolation (R_i) according to the following formula:

$$R_i = R_o \cdot U_b \cdot (1/U_2' - 1/U_2)$$

Figure 3
 Measurement of U_2'

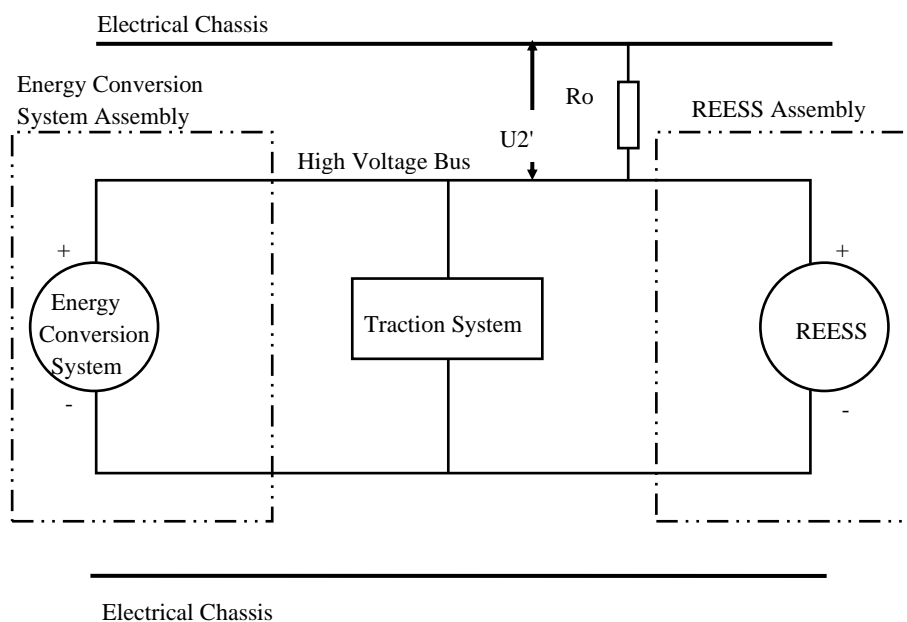

2.2.3.5. Fifth step

The electrical isolation value R_i (in Ω) divided by the working voltage of the high voltage bus (in volts) results in the isolation resistance (in Ω/V).

Note: The standard known resistance R_o (in Ω) should be the value of the minimum required isolation resistance (in Ω/V) multiplied by the working voltage of the vehicle plus/minus 20 per cent (in volts). R_o is not required to be precisely this value since the equations are valid for any R_o ; however, a R_o value in this range should provide good resolution for the voltage measurements.

Annex 5B

Isolation resistance measurement method for component based tests of a REESS

1. Measurement method

The isolation resistance measurement shall be conducted by selecting an appropriate measurement method from among those listed in paragraphs 1.1. through 1.2. of this Annex, depending on the electrical charge of the live parts or the isolation resistance, etc.

Megohmmeter or oscilloscope measurements are appropriate alternatives to the procedure described below for measuring isolation resistance. In this case, it may be necessary to deactivate the on-board isolation resistance monitoring system.

The range of the electrical circuit to be measured shall be clarified in advance, using electrical circuit diagrams, etc. If the high voltage buses are galvanically isolated from each other, isolation resistance shall be measured for each electrical circuit.

If the operating voltage of the Tested-Device (U_b , Figure 1) cannot be measured (e.g. due to disconnection of the electric circuit caused by main contactors or fuse operation) the test may be performed with a modified test device to allow measurement of the internal voltages (upstream the main contactors).

Moreover, modification necessary for measuring the isolation resistance may be carried out, such as removal of the cover in order to reach the live parts, drawing of measurement lines, change in software, etc.

In cases where the measured values are not stable due to the operation of the isolation resistance monitoring system, necessary modification for conducting the measurement may be carried out by stopping the operation of the device concerned or removing it. Furthermore, when the device is removed, a set of drawings will be used to prove that the isolation resistance between the live parts and the ground connection designated by the manufacturer as a point to be connected to the electrical chassis when installed on the vehicle remains unchanged.

These modifications shall not influence the test results.

Utmost care shall be exercised as to short circuit and electric shock, since this confirmation might require direct operations of the high-voltage circuit.

1.1. Measurement method using DC voltage from external sources

1.1.1. Measurement instrument

An isolation resistance test instrument capable of applying a DC voltage higher than the nominal voltage of the Tested-Device shall be used.

1.1.2. Measurement method

An insulation resistance test instrument shall be connected between the live parts and the ground connection. Then, the isolation resistance shall be measured.

If the system has several voltage ranges (e.g. because of boost converter) in a galvanically connected circuit and some of the components cannot withstand the working voltage of the entire circuit, the isolation resistance between

those components and the ground connection can be measured separately by applying at least half of their own working voltage with those component disconnected.

1.2. Measurement method using the Tested-Device as DC voltage source

1.2.1. Test conditions

The voltage level of the Tested-Device throughout the test shall be at least the nominal operating voltage of the Tested-Device.

1.2.2. Measurement instrument

The voltmeter used in this test shall measure DC values and shall have an internal resistance of at least 10 MΩ.

1.2.3. Measurement method

1.2.3.1. First step

The voltage is measured as shown in Figure 1 and the operating voltage of the Tested-Device (U_b , Figure 1) is recorded. U_b shall be equal to or greater than the nominal operating voltage of the Tested-Device.

Figure 1

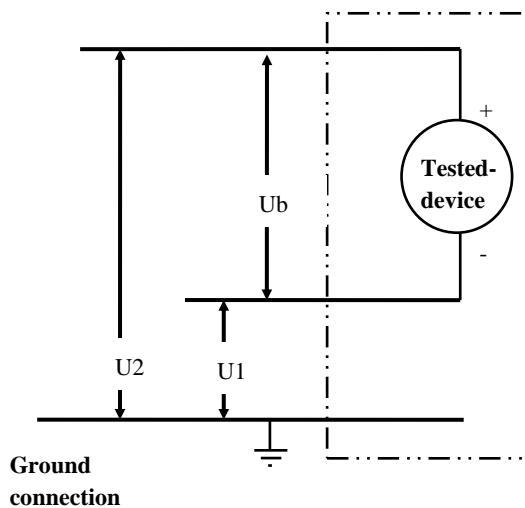

1.2.3.2. Second step

Measure and record the voltage (U_1) between the negative pole of the Tested-Device and the ground connection (Figure 1).

1.2.3.3. Third step

Measure and record the voltage (U_2) between the positive pole of the Tested-Device and the ground connection (Figure 1).

1.2.3.4. Fourth step

If U_1 is greater than or equal to U_2 , insert a standard known resistance (R_o) between the negative pole of the Tested-Device and the ground connection. With R_o installed, measure the voltage (U_1') between the negative pole of the Tested-Device and the ground connection (see Figure 2).

Calculate the electrical isolation (R_i) according to the following formula:

$$R_i = R_o * U_b * (1/U_1' - 1/U_1)$$

Figure 2

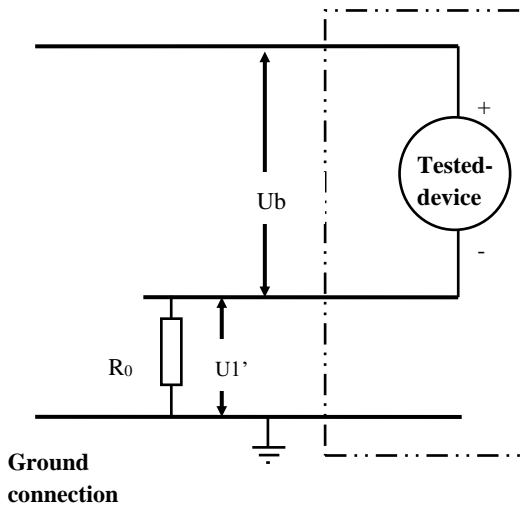

If U_2 is greater than U_1 , insert a standard known resistance (R_0) between the positive pole of the Tested-Device and the ground connection. With R_0 installed, measure the voltage (U_2') between the positive pole of the Tested-Device and the ground connection (see Figure 3).

Calculate the electrical isolation (R_i) according to the following formula:

$$R_i = R_0 \cdot U_b \cdot (1/U_2' - 1/U_2)$$

Figure 3

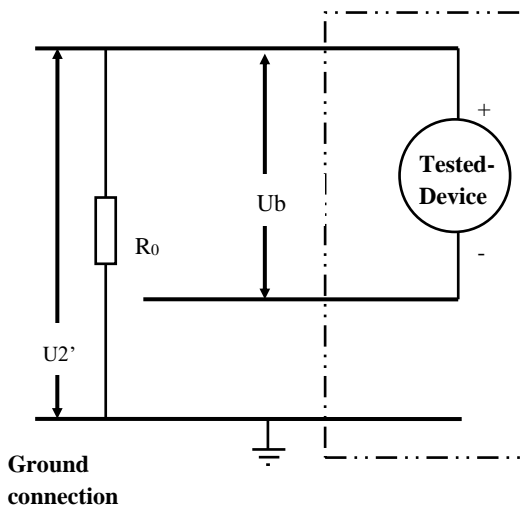

1.2.3.5. Fifth step

The electrical isolation value R_i (in Ω) divided by the nominal voltage of the Tested-Device (in volts) results in the isolation resistance (in Ω/V).

Note : The standard known resistance R_0 (in Ω) should be the value of the minimum required isolation resistance (in Ω/V) multiplied by the nominal voltage of the Tested-Device plus/minus 20 per cent (in V). R_0 is not required to be precisely this value since the equations are valid for any R_0 ; however, a R_0 value in this range should provide good resolution for the voltage measurements.

Annex 6

Confirmation method for the function of an on-board isolation resistance monitoring system

The on-board isolation resistance monitoring system shall be tested using the following procedure:

- (a) Determine the isolation resistance, R_i , of the electric power train with the electrical isolation monitoring system using the procedure outlined Annex 5A.
- (b) If the minimum isolation resistance value required in accordance with paragraphs 5.1.3.1. or 5.1.3.2. is $100 \Omega/V$, insert a resistor with resistance R_o between either side of the high voltage bus that exhibit lower value in U_1 or U_2 measured in accordance with paragraph 2.2.3. of Annex 5A and the electrical chassis. The magnitude of the resistor, R_o , shall be such that:

$$1/(1/(95xU) - 1/R_i) \leq R_o < 1/(1/(100xU) - 1/R_i)$$

where U is the working voltage of the electric power train.

- (c) If the minimum isolation resistance value required in accordance with paragraphs 5.1.3.1. or 5.1.3.2. is $500 \Omega/V$, insert a resistor with resistance R_o between either side of the high voltage bus that exhibit lower value in U_1 or U_2 measured in accordance with paragraph 2.2.3. of Annex 5A and the electrical chassis. The magnitude of the resistor, R_o , shall be such that:

$$1/(1/(475xU) - 1/R_i) \leq R_o < 1/(1/(500xU) - 1/R_i)$$

where U is the working voltage of the electric power train.

Annex 7A

Verification method for testing authorities confirming document based isolation resistance compliance of electrical design of the vehicle after water exposure

This annex describes the applicable requirements when certifying the manufacturer's high voltage equipment or system components against adverse water effects rather than a physical test. As a general rule, the electrical design or components of the vehicles shall comply with the requirements as specified in paragraphs "5.1.1. Protection against direct contact", "5.1.2. Protection against indirect contact", and "5.1.3. Isolation resistance" respectively and this will be separately verified by the testing authority. Vehicle manufacturers shall provide information to testing authorities to identify, as a point of reference, the mounting location for each high-voltage component in/on the vehicle.

1. Documentation shall contain the following information:
 - (a) on how the manufacturer tested isolation resistance compliance of electrical design of the vehicle by using fresh water;
 - (b) on how, after the test had been carried out, the high-voltage component or system was inspected for ingress of water and how, depending on its mounting location, each high voltage component/system met the appropriate degree of protection against water.
2. The testing authority will verify and confirm the authenticity of documented conditions that have been observed, and should have been complied with, during the process of certification by manufacturer:
 - 2.1. It is permitted that, during the test, the moisture contained inside the enclosure is partly condensed. The dew which may be deposited is not considered as ingress of water. For the purpose of the tests, the surface area of the tested high-voltage component or system is calculated with an accuracy of 10 per cent. If possible, the tested high-voltage component or system is run energized. If the tested high-voltage component or system is energized, adequate safety precautions are taken.
 - 2.2. For electrical components, externally attached (e.g. in engine compartment), open underneath, both exposed or protected locations, the testing authority shall verify, with a view to confirming the compliance, whether the test is conducted by spraying the high-voltage component or system from all practicable directions with a stream of water from a standard test nozzle as shown in Figure 1. The following parameters are observed during the test in particular:
 - (a) Nozzle internal diameter: 6.3 mm;
 - (b) Delivery rate: 11.9 – 13.2 l/min;
 - (c) Water pressure at the nozzle: approximately 30 kPa (0.3 bar);
 - (d) Test duration per m² of surface area of the tested high-voltage component or system: 1 min;
 - (e) Minimum test duration: 3 min;
 - (f) Distance from nozzle to tested high-voltage component or system surface: approximately 3 m (this distance may be reduced, if necessary to ensure proper wetting when spraying upwards).

Figure 1
Standard Nozzle for the Test

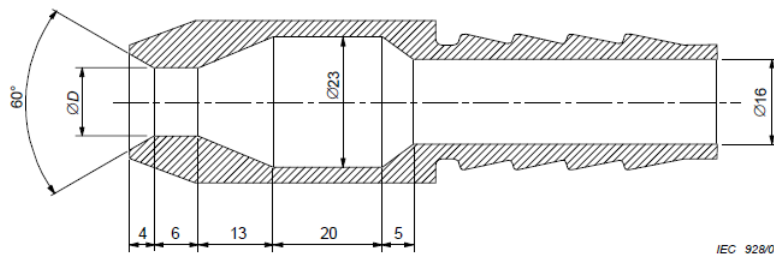

Dimensions in millimetres
 D is 6.3 mm as specified in (a) above.

- 2.3. For electrical components, externally attached (e.g. in engine compartment), covered from underneath, the testing authority shall verify, with a view to confirming the compliance, whether:
- The cover protects the component against direct spray water from underneath and is not visible;
 - The test is conducted by using splashing test nozzle as shown in Figure 2;
 - The moving shield is removed from the spray nozzle and the machine is sprayed from all practicable directions;
 - The water pressure is adjusted to give a delivery rate of (10 ± 0.5) l/min (pressure approximately 80 kPa to 100 kPa (0.8 bar to 1.0 bar));
 - The test duration is 1 min/m^2 of calculated surface area of the machine (excluding any mounting surface and cooling fin) with a minimum duration of 5 min.

Figure 2
Splashing Test Nozzle

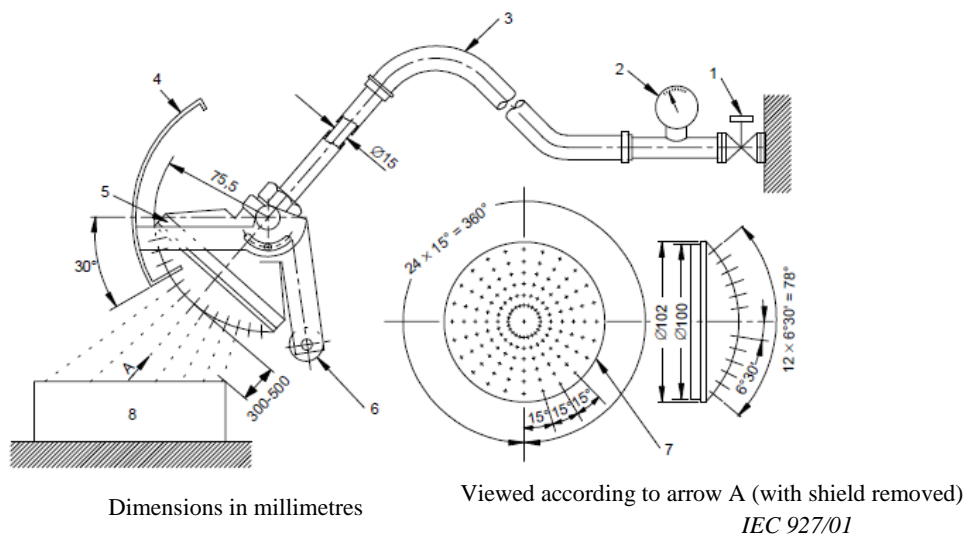

Note:

- Cock
- Pressure gauge
- Hose
- Moving shield – aluminium
- Spray nozzle
- Counter weight
- Spray nozzle – brass with 121 holes $\varnothing 0,5$:
 - hole in centre
 - inner circle of 12 holes at 30° pitch
 - outer circle of 24 holes at 15° pitch
- Machine under test

3. The entire high voltage system or each component is checked to comply with the isolation resistance requirement in paragraph 5.1.3. with the following conditions:
 - (a) The electric chassis shall be simulated by an electric conductor, e.g. a metal plate, and the components are attached with their standard mounting devices to it;
 - (b) Cables, where provided, shall be connected to the component.
4. The parts designed not to be wet during operation are not allowed to be wet and no accumulation of water which could have reached them is tolerated inside the high-voltage component or system.

Annex 7B

Vehicle-based test procedure for protection against water effects

1. Washing

This test is intended to simulate the normal washing of vehicles, but not specific cleaning using high water pressure or underbody washing.

The areas of the vehicle regarding this test are border lines, i.e. a seal of two parts such as flaps, glass seals, outline of opening parts, outline of front grille and seals of lamps.

All border lines shall be exposed and followed in all directions with the water stream using a hose nozzle and conditions in accordance with IPX5 as specified in Annex 7A.

2. Driving through standing water

The vehicle shall be driven in a wade pool, with 10 cm water depth, over a distance of 500 m at a speed of 20 km/h, in a time of approximately 1.5 min. If the wade pool used is less than 500 m in length, then the vehicle shall be driven through it several times. The total time, including the periods outside the wade pool, shall be less than 10 min.

Annex 8

Determination of hydrogen emissions during the charge procedures of the REESS

1. Introduction

This annex describes the procedure for the determination of hydrogen emissions during the charge procedures of the REESS of all road vehicles, according to paragraph 5.4. of this Regulation.
2. Description of test

The hydrogen emission test (Figure 1 of Annex 8) is conducted in order to determine hydrogen emissions during the charge procedures of the REESS with the charger. The test consists in the following steps:

 - (a) Vehicle/REESS preparation;
 - (b) Discharge of the REESS;
 - (c) Determination of hydrogen emissions during a normal charge;
 - (d) Determination of hydrogen emissions during a charge carried out with the charger failure.
3. Tests
 - 3.1. Vehicle based test
 - 3.1.1. The vehicle shall be in good mechanical condition and have been driven at least 300 km during seven days before the test. The vehicle shall be equipped with the REESS subject to the test of hydrogen emissions, over this period.
 - 3.1.2. If the REESS is used at a temperature above the ambient temperature, the operator shall follow the manufacturer's procedure in order to keep the REESS temperature in normal functioning range.

The manufacturer's representative shall be able to certify that the temperature conditioning system of the REESS is neither damaged nor presenting a capacity defect.
 - 3.2. Component based test
 - 3.2.1. The REESS shall be in good mechanical condition and have been subject to minimum of 5 standard cycles (as specified in Annex 9, Appendix 1).
 - 3.2.2. If the REESS is used at a temperature above the ambient temperature, the operator shall follow the manufacturer's procedure in order to keep the REESS temperature in its normal functioning range.

The manufacturer's representative shall be able to certify that the temperature conditioning system of the REESS is neither damaged nor presenting a capacity defect

Figure 1
Determination of hydrogen emissions during the charge procedures of the REESS

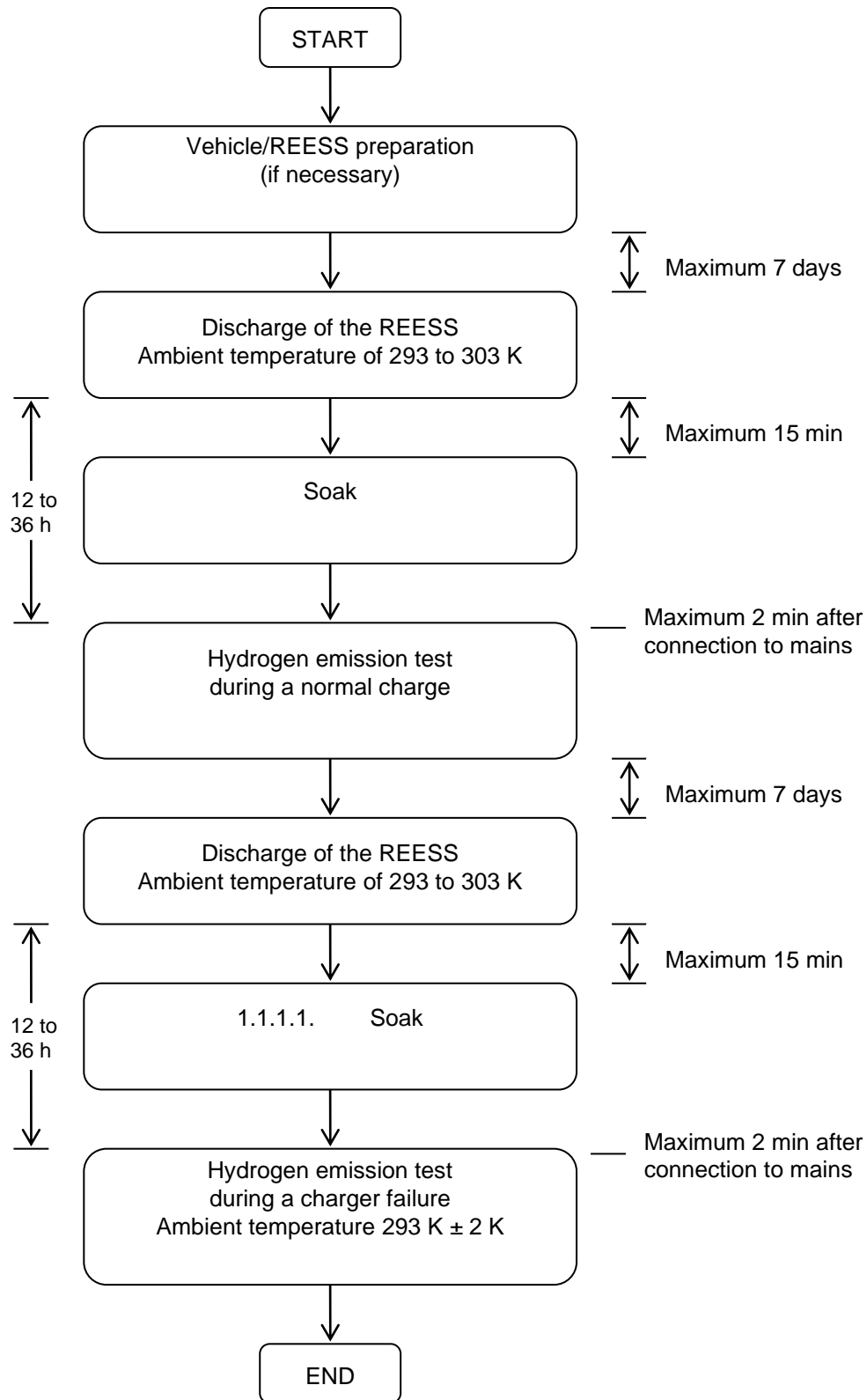

4. Test equipment for hydrogen emission test
 - 4.1. Chassis dynamometer

The chassis dynamometer shall meet the requirements of the 06 series of amendments to Regulation No. 83.
 - 4.2. Hydrogen emission measurement enclosure

The hydrogen emission measurement enclosure shall be a gas-tight measuring chamber able to contain the vehicle/REESS under test. The vehicle/REESS shall be accessible from all sides and the enclosure when sealed shall be gas-tight in accordance with Appendix 1 to this annex. The inner surface of the enclosure shall be impermeable and non-reactive to hydrogen. The temperature conditioning system shall be capable of controlling the internal enclosure air temperature to follow the prescribed temperature throughout the test, with an average tolerance of ± 2 K over the duration of the test.

To accommodate the volume changes due to enclosure hydrogen emissions, either a variable-volume or another test equipment may be used. The variable-volume enclosure expands and contracts in response to the hydrogen emissions in the enclosure. Two potential means of accommodating the internal volume changes are movable panels, or a bellows design, in which impermeable bags inside the enclosure expand and contract in response to internal pressure changes by exchanging air from outside the enclosure. Any design for volume accommodation shall maintain the integrity of the enclosure as specified in Annex 8, Appendix 1.

Any method of volume accommodation shall limit the differential between the enclosure internal pressure and the barometric pressure to a maximum value of ± 5 hPa.

The enclosure shall be capable of latching to a fixed volume. A variable volume enclosure shall be capable of accommodating a change from its "nominal volume" (see Annex 8, Appendix 1, paragraph 2.1.1.), taking into account hydrogen emissions during testing.
 - 4.3. Analytical systems
 - 4.3.1. Hydrogen analyser
 - 4.3.1.1. The atmosphere within the chamber is monitored using a hydrogen analyser (electrochemical detector type) or a chromatograph with thermal conductivity detection. Sample gas shall be drawn from the mid-point of one side-wall or roof of the chamber and any bypass flow shall be returned to the enclosure, preferably to a point immediately downstream of the mixing fan.
 - 4.3.1.2. The hydrogen analyser shall have a response time to 90 per cent of final reading of less than 10 seconds. Its stability shall be better than 2 per cent of full scale at zero and at 80 per cent ± 20 per cent of full scale, over a 15-minute period for all operational ranges.
 - 4.3.1.3. The repeatability of the analyser expressed as one standard deviation shall be better than 1 per cent of full scale, at zero and at 80 per cent ± 20 per cent of full scale on all ranges used.
 - 4.3.1.4. The operational ranges of the analyser shall be chosen to give best resolution over the measurement, calibration and leak checking procedures.

- 4.3.2. Hydrogen analyser data recording system
- The hydrogen analyser shall be fitted with a device to record electrical signal output, at a frequency of at least once per minute. The recording system shall have operating characteristics at least equivalent to the signal being recorded and shall provide a permanent record of results. The recording shall show a clear indication of the beginning and end of the normal charge test and charging failure operation.
- 4.4. Temperature recording
- 4.4.1. The temperature in the chamber is recorded at two points by temperature sensors, which are connected so as to show a mean value. The measuring points are extended approximately 0.1 m into the enclosure from the vertical centre line of each side-wall at a height of 0.9 ± 0.2 m.
- 4.4.2. The temperatures in the proximity of the cells are recorded by means of the sensors.
- 4.4.3. Temperatures shall, throughout the hydrogen emission measurements, be recorded at a frequency of at least once per minute.
- 4.4.4. The accuracy of the temperature recording system shall be within ± 1.0 K and the temperature shall be capable of being resolved to ± 0.1 K.
- 4.4.5. The recording or data processing system shall be capable of resolving time to ± 15 seconds.
- 4.5. Pressure recording
- 4.5.1. The difference Δp between barometric pressure within the test area and the enclosure internal pressure shall, throughout the hydrogen emission measurements, be recorded at a frequency of at least once per minute.
- 4.5.2. The accuracy of the pressure recording system shall be within ± 2 hPa and the pressure shall be capable of being resolved to ± 0.2 hPa.
- 4.5.3. The recording or data processing system shall be capable of resolving time to ± 15 seconds.
- 4.6. Voltage and current intensity recording
- 4.6.1. The charger voltage and current intensity (battery) shall, throughout the hydrogen emission measurements, be recorded at a frequency of at least once per minute.
- 4.6.2. The accuracy of the voltage recording system shall be within ± 1 V and the voltage shall be capable of being resolved to ± 0.1 V.
- 4.6.3. The accuracy of the current intensity recording system shall be within ± 0.5 A and the current intensity shall be capable of being resolved to ± 0.05 A.
- 4.6.4. The recording or data processing system shall be capable of resolving time to ± 15 seconds.
- 4.7. Fans
- The chamber shall be equipped with one or more fans or blowers with a possible flow of 0.1 to 0.5 m³/second in order to thoroughly mix the atmosphere in the enclosure. It shall be possible to reach a homogeneous temperature and hydrogen concentration in the chamber during measurements. The vehicle in the enclosure shall-not be subjected to a direct stream of air from the fans or blowers.
- 4.8. Gases
- 4.8.1. The following pure gases shall be available for calibration and operation:

- (a) Purified synthetic air (purity < 1 ppm C₁ equivalent; < 1 ppm CO; < 400 ppm CO₂; < 0.1 ppm NO); oxygen content between 18 and 21 per cent by volume,
 - (b) Hydrogen (H₂), 99.5 per cent minimum purity.
- 4.8.2. Calibration and span gases shall contain mixtures of hydrogen (H₂) and purified synthetic air. The real concentrations of a calibration gas shall be within ±2 per cent of the nominal values. The accuracy of the diluted gases obtained when using a gas divider shall be within ±2 per cent of the nominal value. The concentrations specified in Annex 8, Appendix 1 may also be obtained by a gas divider using synthetic air as the dilution gas.
- 5. Test procedure

The test consists in the five following steps:

 - (a) Vehicle/REESS preparation;
 - (b) Discharge of the REESS;
 - (c) Determination of hydrogen emissions during a normal charge;
 - (d) Discharge of the traction battery;
 - (e) Determination of hydrogen emissions during a charge carried out with the charger failure.

If the vehicle/REESS has to be moved between two steps, it shall be pushed to the following test area.
- 5.1. Vehicle based test
 - 5.1.1. Vehicle preparation

The ageing of REESS shall be checked, proving that the vehicle has performed at least 300 km during seven days before the test. During this period, the vehicle shall be equipped with the traction battery submitted to the hydrogen emission test. If this cannot be demonstrated then the following procedure will be applied.
 - 5.1.1.1. Discharges and initial charges of the REESS

The procedure starts with the discharge of the REESS of the vehicle while driving on the test track or on a chassis dynamometer at a steady speed of 70 per cent ± 5 per cent of the maximum speed of the vehicle during 30 minutes.

Discharging is stopped:

 - (a) When the vehicle is not able to run at 65 per cent of the maximum thirty minutes speed, or
 - (b) When an indication to stop the vehicle is given to the driver by the standard on-board instrumentation, or
 - (c) After having covered the distance of 100 km.
 - 5.1.1.2. Initial charge of the REESS

The charge is carried out:

 - (a) With the charger;
 - (b) In an ambient temperature between 293 K and 303 K.

The procedure excludes all types of external chargers.

The end of REESS charge criteria corresponds to an automatic stop given by the charger.

This procedure includes all types of special charges that could be automatically or manually initiated like, for instance, the equalisation charges or the servicing charges.

- 5.1.1.3. Procedure from paragraphs 5.1.1.1. and 5.1.1.2. shall be repeated two times.
- 5.1.2. Discharge of the REESS
- The REESS is discharged while driving on the test track or on a chassis dynamometer at a steady speed of 70 per cent \pm 5 per cent from the maximum thirty minutes speed of the vehicle.
- Stopping the discharge occurs:
- (a) When an indication to stop the vehicle is given to the driver by the standard on-board instrumentation, or
 - (b) When the maximum speed of the vehicle is lower than 20 km/h.
- 5.1.3. Soak
- Within fifteen minutes of completing the battery discharge operation specified in paragraph 5.1.2., the vehicle is parked in the soak area. The vehicle is parked for a minimum of 12 hours and a maximum of 36 hours, between the end of the traction battery discharge and the start of the hydrogen emission test during a normal charge. For this period, the vehicle shall be soaked at $293\text{ K} \pm 2\text{ K}$.
- 5.1.4. Hydrogen emission test during a normal charge
- 5.1.4.1. Before the completion of the soak period, the measuring chamber shall be purged for several minutes until a stable hydrogen background is obtained. The enclosure mixing fan(s) shall also be turned on at this time.
- 5.1.4.2. The hydrogen analyser shall be zeroed and spanned immediately prior to the test.
- 5.1.4.3. At the end of the soak, the test vehicle, with the engine shut off and the test vehicle windows and luggage compartment opened shall be moved into the measuring chamber.
- 5.1.4.4. The vehicle shall be connected to the mains. The REESS is charged according to normal charge procedure as specified in paragraph 5.1.4.7. below.
- 5.1.4.5. The enclosure doors are closed and sealed gas-tight within two minutes from electrical interlock of the normal charge step.
- 5.1.4.6. The start of a normal charge for hydrogen emission test period begins when the chamber is sealed. The hydrogen concentration, temperature and barometric pressure are measured to give the initial readings C_{H_2i} , T_1 and P_1 for the normal charge test.
- These figures are used in the hydrogen emission calculation (paragraph 6. of this annex). The ambient enclosure temperature T shall not be less than 291 K and no more than 295 K during the normal charge period.
- 5.1.4.7. Procedure of normal charge
- The normal charge is carried out with the charger and consists of the following steps:
- (a) Charging at constant power during t_1 ;
 - (b) Over-charging at constant current during t_2 . Over-charging intensity is specified by manufacturer and corresponds to the one used during equalisation charging.

- The end of REESS charge criteria corresponds to an automatic stop given by the charger to a charging time of $t_1 + t_2$. This charging time will be limited to $t_1 + 5$ h, even if a clear indication is given to the driver by the standard instrumentation that the battery is not yet fully charged.
- 5.1.4.8. The hydrogen analyser shall be zeroed and spanned immediately before the end of the test.
- 5.1.4.9. The end of the emission sampling period occurs $t_1 + t_2$ or $t_1 + 5$ hours after the beginning of the initial sampling, as specified in Annex 8 paragraph 5.1.4.6. of this annex. The different times elapsed are recorded. The hydrogen concentration, temperature and barometric pressure are measured to give the final readings C_{H_2f} , T_f and P_f for the normal charge test, used for the calculation in Annex 8, paragraph 6.
- 5.1.5. Hydrogen emission test with the charger failure
- 5.1.5.1. Within seven days maximum after having completed the prior test, the procedure starts with the discharge of the REESS of the vehicle according to Annex 8, paragraph 5.1.2.
- 5.1.5.2. The steps of the procedure in Annex 8, paragraph 5.1.3. of this annex shall be repeated.
- 5.1.5.3. Before the completion of the soak period, the measuring chamber shall be purged for several minutes until a stable hydrogen background is obtained. The enclosure mixing fan(s) shall also be turned on at this time.
- 5.1.5.4. The hydrogen analyser shall be zeroed and spanned immediately prior to the test.
- 5.1.5.5. At the end of the soak, the test vehicle, with the engine shut off and the test vehicle windows and luggage compartment opened shall be moved into the measuring chamber.
- 5.1.5.6. The vehicle shall be connected to the mains. The REESS is charged according to failure charge procedure as specified in paragraph 5.1.5.9. below.
- 5.1.5.7. The enclosure doors are closed and sealed gas-tight within two minutes from electrical interlock of the failure charge step.
- 5.1.5.8. The start of a failure charge for hydrogen emission test period begins when the chamber is sealed. The hydrogen concentration, temperature and barometric pressure are measured to give the initial readings C_{H_2i} , T_i and P_i for the failure charge test.
- These figures are used in the hydrogen emission calculation (Annex 8, paragraph 6). The ambient enclosure temperature T shall not be less than 291 K and no more than 295 K during the charging failure period.
- 5.1.5.9. Procedure of charging failure
- The charging failure is carried out with the suitable charger and consists of the following steps:
- (a) Charging at constant power during t'_1 ;
 - (b) Charging at maximum current as recommended by the manufacturer during 30 minutes. During this phase, the charger shall supply maximum current as recommended by the manufacturer.
- 5.1.5.10. The hydrogen analyser shall be zeroed and spanned immediately before the end of the test.

- 5.1.5.11. The end of test period occurs $t_1 + 30$ minutes after the beginning of the initial sampling, as specified in paragraph 5.1.5.8. above. The times elapsed are recorded. The hydrogen concentration, temperature and barometric pressure are measured to give the final readings C_{H_2f} , T_f and P_f for the charging failure test, used for the calculation in Annex 8, paragraph 6.
- 5.2. Component based test
- 5.2.1. REESS preparation
- The ageing of REESS shall be checked, to confirm that the REESS has performed at least 5 standard cycles (as specified in Annex 8, Appendix 1).
- 5.2.2. Discharge of the REESS
- The REESS is discharged at 70 per cent \pm 5 per cent of the nominal power of the system.
- Stopping the discharge occurs when minimum SOC as specified by the manufacturer is reached.
- 5.2.3. Soak
- Within 15 minutes of the end of the REESS discharge operation specified in paragraph 5.2.2. above, and before the start of the hydrogen emission test, the REESS shall be soaked at $293\text{ K} \pm 2\text{ K}$ for a minimum period of 12 hours and a maximum of period of 36 hours.
- 5.2.4. Hydrogen emission test during a normal charge
- 5.2.4.1. Before the completion of the REESS's soak period, the measuring chamber shall be purged for several minutes until a stable hydrogen background is obtained. The enclosure mixing fan(s) shall also be turned on at this time.
- 5.2.4.2. The hydrogen analyser shall be zeroed and spanned immediately prior to the test.
- 5.2.4.3. At the end of the soak period, the REESS shall be moved into the measuring chamber.
- 5.2.4.4. The REESS shall be charged in accordance with the normal charge procedure as specified in paragraph 5.2.4.7. below.
- 5.2.4.5. The chamber shall be closed and sealed gas-tight within two minutes of the electrical interlock of the normal charge step.
- 5.2.4.6. The start of a normal charge for hydrogen emission test period shall begin when the chamber is sealed. The hydrogen concentration, temperature and barometric pressure are measured to give the initial readings C_{H_2i} , T_1 and P_1 for the normal charge test.
- These figures are used in the hydrogen emission calculation (Annex 8, paragraph 6). The ambient enclosure temperature T shall not be less than 291 K and no more than 295 K during the normal charge period.
- 5.2.4.7. Procedure of normal charge
- The normal charge is carried out with a suitable charger and consists of the following steps:
- (a) Charging at constant power during t_1 ;
 - (a) Over-charging at constant current during t_2 . Over-charging intensity is specified by manufacturer and corresponding to that used during equalisation charging.
- The end of REESS charge criteria corresponds to an automatic stop given by the charger to a charging time of $t_1 + t_2$. This charging time will be limited to

$t_1 + 5$ h, even if a clear indication is given by a suitable instrumentation that the REESS is not yet fully charged.

- 5.2.4.8. The hydrogen analyser shall be zeroed and spanned immediately before the end of the test.
- 5.2.4.9. The end of the emission sampling period occurs $t_1 + t_2$ or $t_1 + 5$ h after the beginning of the initial sampling, as specified in paragraph 5.2.4.6. above. The different times elapsed are recorded. The hydrogen concentration, temperature and barometric pressure are measured to give the final readings C_{H_2f} , T_f and P_f for the normal charge test, used for the calculation in Annex 8, paragraph 6.
- 5.2.5. Hydrogen emission test with the charger failure
- 5.2.5.1. The test procedure shall start within a maximum of seven days after having completed the test in paragraph 5.2.4. above, the procedure shall start with the discharge of the REESS of the vehicle in accordance with paragraph 5.2.2. above.
- 5.2.5.2. The steps of the procedure in paragraph 5.2.3. above shall be repeated.
- 5.2.5.3. Before the completion of the soak period, the measuring chamber shall be purged for several minutes until a stable hydrogen background is obtained. The enclosure mixing fan(s) shall also be turned on at this time.
- 5.2.5.4. The hydrogen analyser shall be zeroed and spanned immediately prior to the test.
- 5.2.5.5. At the end of the soak the REESS shall be moved into the measuring chamber.
- 5.2.5.6. The REESS shall be charged according to the failure charge procedure as specified in paragraph 5.2.5.9. below.
- 5.2.5.7. The chamber shall be closed and sealed gas-tight within two minutes from electrical interlock of the failure charge step.
- 5.2.5.8. The start of a failure charge for hydrogen emission test period begins when the chamber is sealed. The hydrogen concentration, temperature and barometric pressure are measured to give the initial readings C_{H_2i} , T_i and P_i for the failure charge test.
- These figures are used in the hydrogen emission calculation (Annex 8, paragraph 6.). The ambient enclosure temperature T shall not be less than 291 K and no more than 295 K during the charging failure period.
- 5.2.5.9. Procedure of charging failure
- The charging failure is carried out with a suitable charger and consists of the following steps:
- (a) Charging at constant power during t'_1 ,
 - (b) Charging at maximum current as recommended by the manufacturer during 30 minutes. During this phase, the charger shall supply maximum current as recommended by the manufacturer.
- 5.2.5.10. The hydrogen analyser shall be zeroed and spanned immediately before the end of the test.
- 5.2.5.11. The end of test period occurs $t'_1 + 30$ minutes after the beginning of the initial sampling, as specified in paragraph 5.2.5.8. above. The times elapsed are recorded. The hydrogen concentration, temperature and barometric pressure are measured to give the final readings C_{H_2f} , T_f and P_f for the charging failure test, used for the calculation in paragraph 6. below.

6. Calculation

The hydrogen emission tests described in paragraph 5. above allow the calculation of the hydrogen emissions from the normal charge and charging failure phases. Hydrogen emissions from each of these phases are calculated using the initial and final hydrogen concentrations, temperatures and pressures in the enclosure, together with the net enclosure volume.

The formula below is used:

$$M_{H_2} = k \times V \times 10^{-4} \times \left(\frac{\left(1 + \frac{V_{out}}{V}\right) \times C_{H_2f} \times P_f}{T_f} - \frac{C_{H_2i} \times P_i}{T_i} \right)$$

Where:

M_{H_2} = hydrogen mass, in grams

C_{H_2} = measured hydrogen concentration in the enclosure, in ppm volume

V = net enclosure volume in cubic metres (m^3) corrected for the volume of the vehicle, with the windows and the luggage compartment open. If the volume of the vehicle is not determined a volume of 1.42 m^3 is subtracted.

V_{out} = compensation volume in m^3 , at the test temperature and pressure

T = ambient chamber temperature, in K

P = absolute enclosure pressure, in kPa

k = 2.42

Where: i is the initial reading

f is the final reading

6.1. Results of test

The hydrogen mass emissions for the REESS are:

M_N = hydrogen mass emission for normal charge test, in grams

M_D = hydrogen mass emission for charging failure test, in grams

Annex 8 - Appendix 1

Calibration of equipment for hydrogen emission testing

1. Calibration frequency and methods

All equipment shall be calibrated before its initial use and then calibrated as often as necessary and in any case in the month before type approval testing. The calibration methods to be used are described in this appendix.
2. Calibration of the enclosure
 - 2.1. Initial determination of enclosure internal volume
 - 2.1.1. Before its initial use, the internal volume of the chamber shall be determined as follows. The internal dimensions of the chamber are carefully measured, taking into account any irregularities such as bracing struts. The internal volume of the chamber is determined from these measurements.

The enclosure shall be latched to a fixed volume when the enclosure is held at an ambient temperature of 293 K. This nominal volume shall be repeatable within ± 0.5 per cent of the reported value.
 - 2.1.2. The net internal volume is determined by subtracting 1.42 m³ from the internal volume of the chamber. Alternatively the volume of the test vehicle with the luggage compartment and windows open or REESS may be used instead of the 1.42 m³.
 - 2.1.3. The chamber shall be checked as in Annex 8, paragraph 2.3. If the hydrogen mass does not agree with the injected mass to within ± 2 per cent then corrective action is required.
 - 2.2. Determination of chamber background emissions

This operation determines that the chamber does not contain any materials that emit significant amounts of hydrogen. The check shall be carried out at the enclosure's introduction to service, after any operations in the enclosure which may affect background emissions and at a frequency of at least once per year.

 - 2.2.1. Variable-volume enclosure may be operated in either latched or unlatched volume configuration, as described in paragraph 2.1.1. above. Ambient temperature shall be maintained at 293 K \pm 2 K, throughout the four-hour period mentioned below.
 - 2.2.2. The enclosure may be sealed and the mixing fan operated for a period of up to 12 hours before the four-hour background-sampling period begins.
 - 2.2.3. The analyser (if required) shall be calibrated, then zeroed and spanned.
 - 2.2.4. The enclosure shall be purged until a stable hydrogen reading is obtained, and the mixing fan turned on if not already on.
 - 2.2.5. The chamber is then sealed and the background hydrogen concentration, temperature and barometric pressure are measured. These are the initial readings C_{H2i} , T_i and P_i used in the enclosure background calculation.
 - 2.2.6. The enclosure is allowed to stand undisturbed with the mixing fan on for a period of four hours.
 - 2.2.7. At the end of this time the same analyser is used to measure the hydrogen concentration in the chamber. The temperature and the barometric pressure are also measured. These are the final readings C_{H2f} , T_f and P_f .

- 2.2.8. The change in mass of hydrogen in the enclosure shall be calculated over the time of the test in accordance with Annex 8, paragraph 2.4. and shall not exceed 0.5 g.
- 2.3. Calibration and hydrogen retention test of the chamber
- The calibration and hydrogen retention test in the chamber provides a check on the calculated volume (paragraph 2.1. above) and also measures any leak rate. The enclosure leak rate shall be determined at the enclosure's introduction to service, after any operations in the enclosure which may affect the integrity of the enclosure, and at least monthly thereafter. If six consecutive monthly retention checks are successfully completed without corrective action, the enclosure leak rate may be determined quarterly thereafter as long as no corrective action is required.
- 2.3.1. The enclosure shall be purged until a stable hydrogen concentration is reached. The mixing fan is turned on, if not already switched on. The hydrogen analyser is zeroed, calibrated if required, and spanned.
- 2.3.2. The enclosure shall be latched to the nominal volume position.
- 2.3.3. The ambient temperature control system is then turned on (if not already on) and adjusted for an initial temperature of 293 K.
- 2.3.4. When the enclosure temperature stabilizes at $293\text{ K} \pm 2\text{ K}$, the enclosure is sealed and the background concentration, temperature and barometric pressure measured. These are the initial readings C_{H_2i} , T_i and P_i used in the enclosure calibration.
- 2.3.5. The enclosure shall be unlatched from the nominal volume.
- 2.3.6. A quantity of approximately 100 g of hydrogen is injected into the enclosure. This mass of hydrogen shall be measured to an accuracy of ± 2 per cent of the measured value.
- 2.3.7. The contents of the chamber shall be allowed to mix for five minutes and then the hydrogen concentration, temperature and barometric pressure are measured. These are the final readings C_{H_2f} , T_f and P_f for the calibration of the enclosure as well as the initial readings C_{H_2i} , T_i and P_i for the retention check.
- 2.3.8. On the basis of the readings taken in paragraphs 2.3.4 and 2.3.7 above and the formula in paragraph 2.4. below, the mass of hydrogen in the enclosure is calculated. This shall be within ± 2 per cent of the mass of hydrogen measured in paragraph 2.3.6. above.
- 2.3.9. The contents of the chamber shall be allowed to mix for a minimum of 10 hours. At the completion of the period, the final hydrogen concentration, temperature and barometric pressure are measured and recorded. These are the final readings C_{H_2f} , T_f and P_f for the hydrogen retention check.
- 2.3.10. Using the formula in paragraph 2.4. below, the hydrogen mass is then calculated from the readings taken in paragraphs 2.3.7 and 2.3.9. above. This mass may not differ by more than 5 per cent from the hydrogen mass given by paragraph 2.3.8. above.
- 2.4. Calculation
- The calculation of net hydrogen mass change within the enclosure is used to determine the chamber's hydrocarbon background and leak rate. Initial and final readings of hydrogen concentration, temperature and barometric pressure are used in the following formula to calculate the mass change.

$$M_{H_2} = k \times V \times 10^{-4} \times \left(\frac{\left(1 + \frac{V_{out}}{V}\right) \times C_{H_2f} \times P_f}{T_f} - \frac{C_{H_2i} \times P_i}{T_i} \right)$$

Where:

- M_{H_2} = hydrogen mass, in grams
 C_{H_2} = measured hydrogen concentration into the enclosure, in ppm volume
 V = enclosure volume in cubic metres (m³) as measured in paragraph 2.1.1. above.
 V_{out} = compensation volume in m³, at the test temperature and pressure
 T = ambient chamber temperature, in K
 P = absolute enclosure pressure, in kPa
 k = 2.42

Where: i is the initial reading

f is the final reading

3. Calibration of the hydrogen analyser

The analyser should be calibrated using hydrogen in air and purified synthetic air. See Annex 8, paragraph 4.8.2.

Each of the normally used operating ranges are calibrated by the following procedure:

- 3.1. Establish the calibration curve by at least five calibration points spaced as evenly as possible over the operating range. The nominal concentration of the calibration gas with the highest concentrations to be at least 80 per cent of the full scale.
- 3.2. Calculate the calibration curve by the method of least squares. If the resulting polynomial degree is greater than three, then the number of calibration points shall be at least the number of the polynomial degree plus two.
- 3.3. The calibration curve shall not differ by more than two per cent from the nominal value of each calibration gas.
- 3.4. Using the coefficients of the polynomial derived from paragraph 3.2. above, a table of analyser readings against true concentrations shall be drawn by steps no greater than 1 per cent of full scale. This is to be carried out for each analyser range calibrated.

This table shall also contain other relevant data such as:

- (a) Date of calibration;
- (b) Span and zero potentiometer readings (where applicable);
- (c) Nominal scale;
- (d) Reference data of each calibration gas used;
- (e) Real and indicated value of each calibration gas used together with the percentage differences;
- (f) Calibration pressure of analyser.

- 3.5. Alternative methods (e.g. computer, electronically controlled range switch) can be used if it is proven to the technical service that these methods give equivalent accuracy.

Annex 8 - Appendix 2

Essential characteristics of the vehicle family

1. Parameters defining the family relative to hydrogen emissions

The family may be defined by basic design parameters which shall be common to vehicles within the family. In some cases there may be interaction of parameters. These effects shall also be taken into consideration to ensure that only vehicles with similar hydrogen emission characteristics are included within the family.
2. To this end, those vehicle types whose parameters described below are identical are considered to belong to the same hydrogen emissions.

REESS:

- (a) Trade name or mark of the REESS;
- (b) Indication of all types of electrochemical couples used;
- (c) Number of REESS cells;
- (d) Number of REESS subsystems;
- (e) Nominal voltage of the REESS (V);
- (f) REESS energy (kWh);
- (g) Gas combination rate (in per cent);
- (h) Type(s) of ventilation for REESS subsystem(s);
- (i) Type of cooling system (if any).

On-board charger:

- (a) Make and type of different charger parts;
- (b) Output nominal power (kW);
- (c) Maximum voltage of charge (V);
- (d) Maximum intensity of charge (A);
- (e) Make and type of control unit (if any);
- (f) Diagram of operating, controls and safety;
- (g) Characteristics of charge periods.

Annex 9

REESS test procedures

Annex 9 - Appendix 1

Procedure for conducting a standard cycle

A standard cycle shall start with a standard discharge followed by a standard charge. The standard cycle shall be conducted at an ambient temperature of 20 ± 10 °C.

Standard discharge:

Discharge rate: The discharge procedure including termination criteria shall be defined by the manufacturer. If not specified, then it shall be a discharge with 1C current for a complete REESS and REESS subsystems.

Discharge limit (end voltage): Specified by the manufacturer

For a complete vehicle, discharge procedure using a dynamometer shall be defined by the manufacturer. Discharge termination will be according to vehicle controls.

Rest period after discharge: Minimum 15 min

Standard charge:

The charge procedure shall be defined by the manufacturer. If not specified, then it shall be a charge with C/3 current. Charging is continued until normally terminated. Charge termination shall be according to paragraph 2. of Annex 9, Appendix 2 for REESS or REESS subsystem.

For a complete vehicle that can be charged by an external source, charge procedure using an external electric power supply shall be defined by the manufacturer. For a complete vehicle that can be charged by on-board energy sources, a charge procedure using a dynamometer shall be defined by the manufacturer. Charge termination will be according to vehicle controls.

Annex 9 – Appendix 2

Procedure for SOC adjustment

1. The adjustment of SOC shall be conducted at an ambient temperature of 20 ± 10 °C for vehicle-based tests and 22 ± 5 °C for component-based tests.
2. The SOC of the Tested-Device shall be adjusted according to one of the following procedures as applicable. Where different charging procedures are possible, the REESS shall be charged using the procedure which yields the highest SOC:
 - (a) For a vehicle with a REESS designed to be externally charged, the REESS shall be charged to the highest SOC in accordance with the procedure specified by the manufacturer for normal operation until the charging process is normally terminated;
 - (b) For a vehicle with a REESS designed to be charged only by an energy source on the vehicle, the REESS shall be charged to the highest SOC which is achievable with normal operation of the vehicle. The manufacturer shall advise on the vehicle operation mode to achieve this SOC;
 - (c) In case that the REESS or REESS subsystem is used as the Tested-Device, the Tested-Device shall be charged to the highest SOC in accordance with the procedure specified by the manufacturer for normal use operation until the charging process is normally terminated. Procedures specified by the manufacturer for manufacturing, service or maintenance may be considered as appropriate if they achieve an equivalent SOC as for that under normal operating conditions. In case the Tested-Device does not control SOC by itself, the SOC shall be charged to not less than 95 per cent of the maximum normal operating SOC defined by the manufacturer for the specific configuration of the Tested-Device.
3. When the vehicle or REESS subsystem is tested, the SOC shall be no less than 95 per cent of the SOC according to paragraphs 1. and 2. above for REESS designed to be externally charged and shall be no less than 90 per cent of SOC according to paragraphs 1. and 2. above for REESS designed to be charged only by an energy source on the vehicle. The SOC will be confirmed by a method provided by the manufacturer.

Annex 9A

Vibration test

1. Purpose

The purpose of this test is to verify the safety performance of the REESS under a vibration environment which the REESS will likely experience during the normal operation of the vehicle.

2. Installations

2.1. This test shall be conducted either with the complete REESS or with REESS subsystem(s). If the manufacturer chooses to test with REESS subsystem(s), the manufacturer shall demonstrate that the test result can reasonably represent the performance of the complete REESS with respect to its safety performance under the same conditions. If the electronic management unit for the REESS is not integrated in the casing enclosing the cells, then the electronic management unit may be omitted from installation on the Tested-Device if so requested by the manufacturer.

2.2. The Tested-Device shall be firmly secured to the platform of the vibration machine in such a manner as to ensure that the vibrations are directly transmitted to the Tested-Device.

The Tested-Device should be mounted with its original mounting points, if those exist in the Tested-Device, as mounted in the vehicle.

3. Procedures

3.1. General test conditions

The following conditions shall apply to the Tested-Device:

- (a) The test shall be conducted at an ambient temperature of 22 ± 5 °C;
- (b) At the beginning of the test, the SOC shall be adjusted in accordance with Annex 9, Appendix 2;
- (c) At the beginning of the test, all protection devices which affect the function(s) of the Tested-Device that are relevant to the outcome of the test shall be operational.

3.2. Test procedures

The Tested-Devices shall be subjected to a vibration having a sinusoidal waveform with a logarithmic sweep between 7 Hz and 50 Hz and back to 7 Hz traversed in 15 minutes. This cycle shall be repeated 12 times for a total of 3 hours in the vertical direction of the mounting orientation of the REESS as specified by the manufacturer.

The correlation between frequency and acceleration shall be as shown in Table 1:

Table 1
Frequency and acceleration

<i>Frequency (Hz)</i>	<i>Acceleration (m/s²)</i>
7 - 18	10
18 - 30	gradually reduced from 10 to 2
30 - 50	2

At the request of the manufacturer, a higher acceleration level as well as a higher maximum frequency may be used.

At the request of the manufacturer a vibration test profile determined by the vehicle-manufacturer, verified for the vehicle application and agreed with the Technical Service may be used as a substitute for the frequency - acceleration correlation of Table 1. The approval of a REESS tested according to this condition shall be limited to the installation for a specific vehicle type.

After the vibration, a standard cycle as described in Annex 9, Appendix 1 shall be conducted, if not inhibited by the Tested-Device.

The test shall end with an observation period of 1 h at the ambient temperature conditions of the test environment.

Annex 9B

Thermal shock and cycling test

1. Purpose

The purpose of this test is to verify the resistance of the REESS to sudden changes in temperature. The REESS shall undergo a specified number of temperature cycles, which start at ambient temperature followed by high and low temperature cycling. It simulates a rapid environmental temperature change which a REESS would likely experience during its life.

2. Installations

This test shall be conducted either with the complete REESS or with related REESS subsystem(s). If the manufacturer chooses to test with REESS subsystem(s), the manufacturer shall demonstrate that the test result can reasonably represent the performance of the complete REESS with respect to its safety performance under the same conditions. If the electronic management unit for the REESS is not integrated in the casing enclosing the cells, then the electronic management unit may be omitted from installation on the Tested-Device if so requested by the manufacturer.

3. Procedures

3.1. General test conditions

The following conditions shall apply to the Tested-Device at the start of the test:

- (a) The SOC shall be adjusted in accordance with Annex 9, Appendix 2;
- (b) All protection devices, which would affect the function of the Tested-Device and which are relevant to the outcome of the test shall be operational.

3.2. Test procedure

The Tested-Device shall be stored for at least six hours at a test temperature equal to 60 ± 2 °C or higher if requested by the manufacturer, followed by storage for at least six hours at a test temperature equal to -40 ± 2 °C or lower if requested by the manufacturer. The maximum time interval between test temperature extremes shall be 30 minutes. This procedure shall be repeated until a minimum of 5 total cycles are completed, after which the Tested-Device shall be stored for 24 hours at an ambient temperature of 22 ± 5 °C.

After the storage for 24 hours, a standard cycle as described in Annex 9, Appendix 1 shall be conducted, if not inhibited by the Tested-Device.

The test shall end with an observation period of 1 h at the ambient temperature conditions of the test environment.

Annex 9C

Mechanical shock

1. Purpose

The purpose of this test is to verify the safety performance of the REESS under inertial loads which may occur during a vehicle crash.
2. Installation
- 2.1. This test shall be conducted either with the complete REESS or with REESS subsystem(s). If the manufacturer chooses to test with REESS subsystem(s), the manufacturer shall demonstrate that the test result can reasonably represent the performance of the complete REESS with respect to its safety performance under the same conditions. If the electronic management unit for the REESS is not integrated in the casing enclosing the cells, then the electronic management unit may be omitted from installation on the Tested-Device if so requested by the manufacturer
- 2.2. The Tested-Device shall be connected to the test fixture only by the intended mountings provided for the purpose of attaching the REESS or REESS subsystem to the vehicle.
3. Procedures
- 3.1. General test conditions and requirements

The following condition shall apply to the test:

 - (a) The test shall be conducted at an ambient temperature of 20 ± 10 °C,
 - (b) At the beginning of the test, the SOC shall be adjusted in accordance with Annex 9, Appendix 2;
 - (c) At the beginning of the test, all protection devices which affect the function of the Tested-Device and which are relevant to the outcome of the test, shall be operational.
- 3.2. Test procedure

The Tested-Device shall be decelerated or accelerated in compliance with the acceleration corridors which are specified in Tables 1 to 3. The manufacturer shall decide whether the tests shall be conducted in either the positive or negative direction or both.

For each of the test pulses specified, a separate Tested-Device may be used.

The test pulse shall be within the minimum and maximum value as specified in Tables 1 to 3. A higher shock level and /or longer duration as described in the maximum value in Tables 1 to 3 can be applied to the Tested-Device if recommended by the manufacturer.

The test shall end with an observation period of 1 hour at the ambient temperature conditions of the test environment.

Figure 1
 Generic description of test pulses

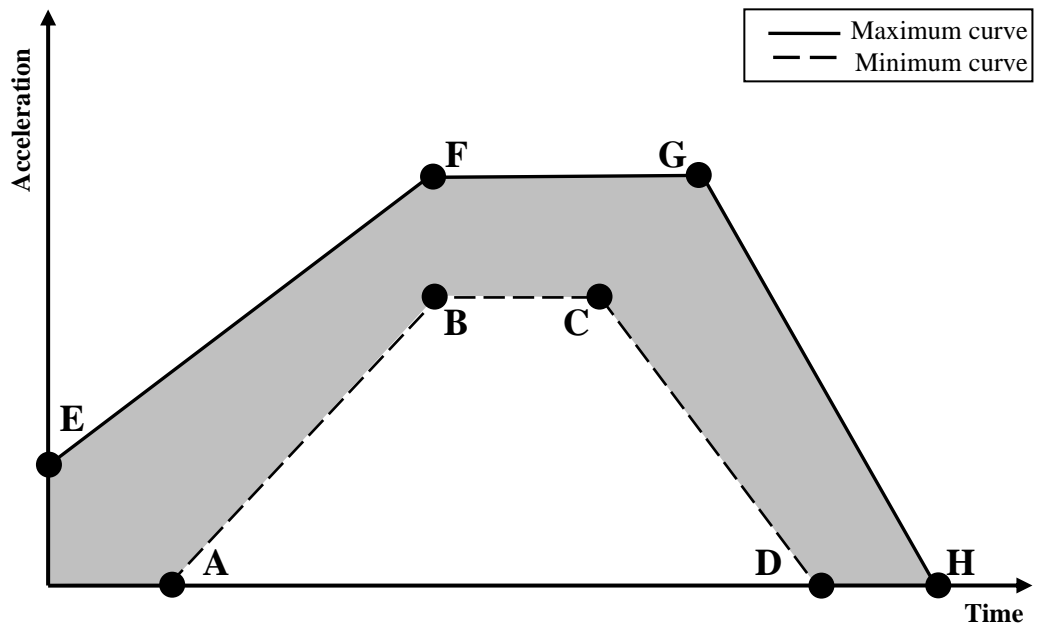

Table 1 for M₁ and N₁ vehicles:

Point	Time (ms)	Acceleration (g)	
		Longitudinal	Transverse
A	20	0	0
B	50	20	8
C	65	20	8
D	100	0	0
E	0	10	4.5
F	50	28	15
G	80	28	15
H	120	0	0

Table 2 for M₂ and N₂ vehicles:

Point	Time (ms)	Acceleration (g)	
		Longitudinal	Transverse
A	20	0	0
B	50	10	5
C	65	10	5
D	100	0	0
E	0	5	2.5
F	50	17	10

G	80	17	10
H	120	0	0

Table 3 for M₃ and N₃ vehicles:

<i>Point</i>	<i>Time (ms)</i>	<i>Acceleration (g)</i>	
		<i>Longitudinal</i>	<i>Transverse</i>
A	20	0	0
B	50	6,6	5
C	65	6,6	5
D	100	0	0
E	0	4	2.5
F	50	12	10
G	80	12	10
H	120	0	0

The test shall end with an observation period of 1 h at the ambient temperature conditions of the test environment.

Annex 9D

Mechanical integrity

1. Purpose

The purpose of this test is to verify the safety performance of the REESS under contact loads which may occur during vehicle crash situation.
2. Installations
 - 2.1. This test shall be conducted with either the complete REESS or with a related REESS subsystem(s) including the cells and their electrical connections. If the manufacturer chooses to test with related subsystem(s), the manufacturer shall demonstrate that the test result can reasonably represent the performance of the complete REESS with respect to its safety performance under the same conditions. If the electronic management unit for the REESS is not integrated in the casing enclosing the cells, then the electronic management unit may be omitted from installation on the Tested-Device if so requested by the manufacturer.
 - 2.2. The Tested-Device shall be connected to the test fixture as recommended by the manufacturer.
3. Procedures
 - 3.1. General test conditions

The following condition and requirements shall apply to the test:

 - (a) The test shall be conducted at an ambient temperature of 20 ± 10 °C;
 - (b) At the beginning of the test, the SOC shall be adjusted in accordance with Annex 9, Appendix 2;
 - (c) At the beginning of the test, all internal and external protection devices which would affect the function of the Tested-Device and which are relevant to the outcome of the test shall be operational.
 - (d) In case where paragraph 6.4.2.1.2. is applied, vehicle body structure, electrical protection barriers, enclosures, or other mechanical functional devices providing protection against contact regardless of whether outside or inside of the REESS may be attached to the Tested-Device if so requested by the manufacturer. The manufacturer shall define the relevant parts used for the mechanical protection of the REESS. The test may be conducted with the REESS mounted to this vehicle structure in a way which is representative of its mounting in the vehicle.
 - 3.2. Crush test
 - 3.2.1. Crush force

The Tested-Device shall be crushed between a resistance and a crush plate as described in Figure 1 with a force of at least 100 kN, but not exceeding 105 kN, unless otherwise specified in accordance with paragraph 6.4.2. of this Regulation, with an onset time less than 3 minutes and a hold time of at least 100 ms but not exceeding 10 s.

Figure 1

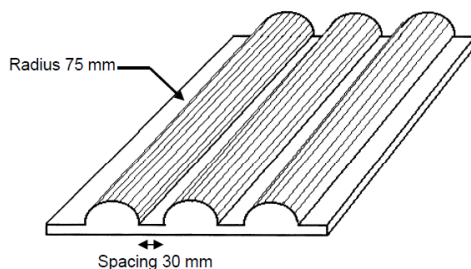

Dimension of the crush plate:
600 mm x 600 mm or smaller

A higher crush force, a longer onset time, a longer hold time, or a combination of these, may be applied at the request of the manufacturer.

The application of the force shall be decided by the manufacturer having consideration to the direction of travel of the REESS relative to its installation in the vehicle. The application force being applied horizontally and perpendicular to the direction of travel of the REESS.

The test shall end with an observation period of 1 h at the ambient temperature conditions of the test environment.

Annex 9E

Fire resistance

1. Purpose

The purpose of this test is to verify the resistance of the REESS, against exposure to fire from outside of the vehicle due to e.g. a fuel spill from a vehicle (either the vehicle itself or a nearby vehicle). This situation should leave the driver and passengers with enough time to evacuate.
2. Installations
- 2.1. This test shall be conducted either with the complete REESS or with REESS subsystem(s). If the manufacturer chooses to test with REESS subsystem(s), the manufacturer shall demonstrate that the test result can reasonably represent the performance of the complete REESS with respect to its safety performance under the same conditions. If the electronic management unit for the REESS is not integrated in the casing enclosing the cells, then the electronic management unit may be omitted from installation on the Tested-Device if so requested by the manufacturer. Where the relevant REESS subsystems are distributed throughout the vehicle, the test may be conducted on each relevant of the REESS subsystem.
3. Procedures
- 3.1. General test conditions

The following requirements and conditions shall apply to the test:

 - (a) The test shall be conducted at a temperature of at least 0 °C;
 - (b) At the beginning of the test, the SOC shall be adjusted in accordance with Annex 9, Appendix 2;
 - (c) At the beginning of the test, all protection devices which affect the function of the Tested-Device and are relevant for the outcome of the test shall be operational..
- 3.2. Test procedure

A vehicle based test or a component based test shall be performed at the discretion of the manufacturer:
- 3.2.1. Vehicle based test

The Tested-Device shall be mounted in a testing fixture simulating actual mounting conditions as far as possible; no combustible material should be used for this with the exception of material that is part of the REESS. The method whereby the Tested-Device is fixed in the fixture shall correspond to the relevant specifications for its installation in a vehicle. In the case of a REESS designed for a specific vehicle use, vehicle parts which affect the course of the fire in any way shall be taken into consideration.
- 3.2.2. Component based test

In case of component based test, the manufacturer may choose either gasoline pool fire test or LPG burner test.

The Tested-Device shall be placed on a grating table positioned above the pan, in an orientation according to the manufacturer's design intent.

The grating table shall be constructed by steel rods, diameter 6-10 mm, with 4-6 cm in between. If needed the steel rods could be supported by flat steel parts.

- 3.3. Gasoline pool fire test set up for both vehicle-based and component-based test.
- The flame to which the Tested-Device is exposed shall be obtained by burning commercial fuel for positive-ignition engines (hereafter called "fuel") in a pan. The quantity of fuel shall be sufficient to permit the flame, under free-burning conditions, to burn for the whole test procedure.
- The fire shall cover the whole area of the pan during whole fire exposure. The pan dimensions shall be chosen so as to ensure that the sides of the Tested-Device are exposed to the flame. The pan shall therefore exceed the horizontal projection of the Tested-Device by at least 20 cm, but not more than 50 cm. The sidewalls of the pan shall not project more than 8 cm above the level of the fuel at the start of the test.
- 3.3.1. The pan filled with fuel shall be placed under the Tested-Device in such a way that the distance between the level of the fuel in the pan and the bottom of the Tested-Device corresponds to the design height of the Tested-Device above the road surface at the unladen mass if paragraph 3.2.1. above is applied or approximately 50 cm if paragraph 3.2.2. above is applied. Either the pan, or the testing fixture, or both, shall be freely movable.
- 3.3.2. During phase C of the test, the pan shall be covered by a screen. The screen shall be placed 3 cm +/- 1 cm above the fuel level measured prior to the ignition of the fuel. The screen shall be made of a refractory material, as prescribed in Annex 9E - Appendix 1. There shall be no gap between the bricks and they shall be supported over the fuel pan in such a manner that the holes in the bricks are not obstructed. The length and width of the frame shall be 2 cm to 4 cm smaller than the interior dimensions of the pan so that a gap of 1 cm to 2 cm exists between the frame and the wall of the pan to allow ventilation. Before the test the screen shall be at least at the ambient temperature. The firebricks may be wetted in order to guarantee repeatable test conditions.
- 3.3.3. If the tests are carried out in the open air, sufficient wind protection shall be provided and the wind velocity at pan level shall not exceed 2.5 km/h.
- 3.3.4. The test shall comprise of three phases B-D, if the fuel is at least at temperature of 20 °C. Otherwise the test shall comprise four phases A-D.
- 3.3.4.1. Phase A: Pre-heating (Figure 1)
- The fuel in the pan shall be ignited at a distance of at least 3 m from the Tested-Device. After 60 seconds pre-heating, the pan shall be placed under the Tested-Device. If the size of the pan is too large to be moved without risking liquid spills etc. then the Tested-Device and test rig can be moved over the pan instead.

Figure 1
Phase A: Pre-heating

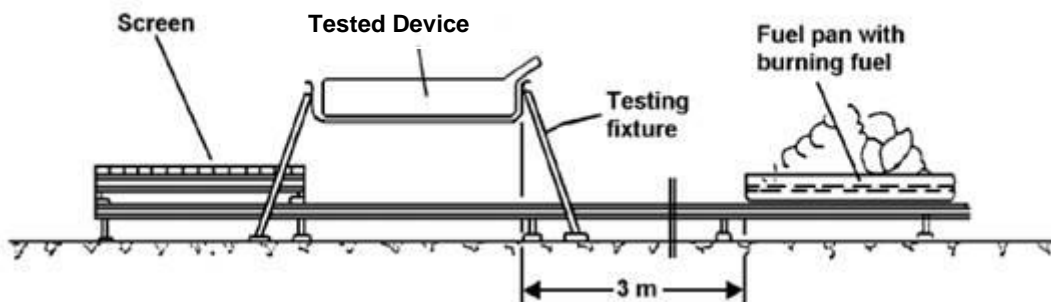

3.3.4.2. Phase B: Direct exposure to flame (Figure 2)

The Tested-Device shall be exposed to the flame from the freely burning fuel for 70 seconds.

Figure 2
Phase B: Direct exposure to flame

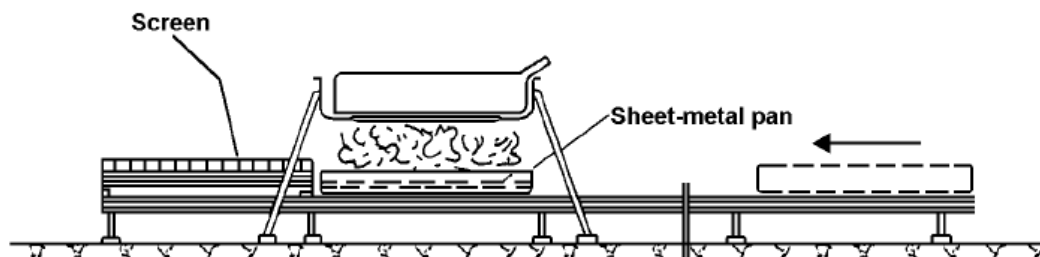

3.3.4.3. Phase C: Indirect exposure to flame (Figure 3)

As soon as phase B has been completed, the screen shall be placed between the burning pan and the Tested-Device. The Tested-Device shall be exposed to this reduced flame for a further 60 seconds.

Instead of conducting phase C of the test, phase B may at the manufacturer's discretion be continued for an additional 60 seconds.

Figure 3
Phase C: Indirect exposure to flame

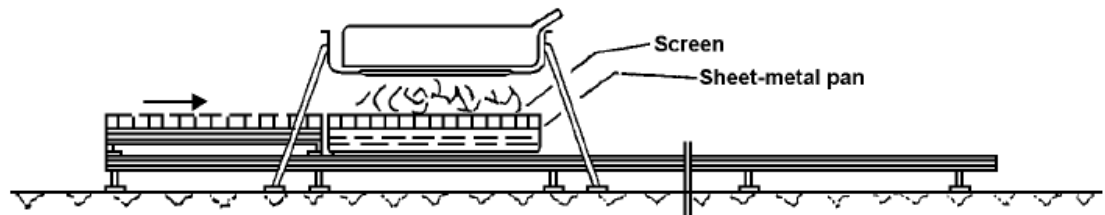

3.3.4.4. Phase D: End of test (Figure 4)

The burning pan covered with the screen shall be moved back to the position described in phase A. No extinguishing of the Tested-Device shall be done. After removal of the pan the Tested-Device shall be observed until such time as the surface temperature of the Tested-Device has decreased to ambient temperature or has been decreasing for a minimum of 3 hours.

Figure 4
Phase D: End of test

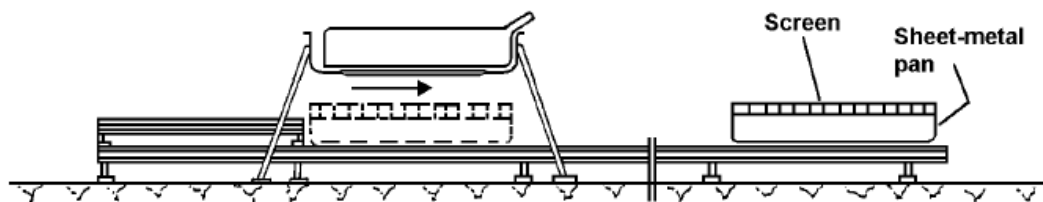

- 3.4. LPG burner fire test set up for component based test
- 3.4.1. The Tested-Device shall be placed on a test equipment, in the position that the manufacturer's design intends.
- 3.4.2. LPG burner shall be used to produce flame to which the Tested-Device is exposed. The height of the flame shall be about 60 cm or more, without the Tested-Device.
- 3.4.3. The flame temperature shall be measured continuously by temperature sensors. An average temperature shall be calculated, at least every second for the duration of the whole fire exposure, as the arithmetic average of temperatures measured by all temperature sensors fulfilling the location requirements described in paragraph 3.4.4.
- 3.4.4. All temperature sensors shall be installed at a height of 5 ± 1 cm below the lowest point of the Tested-Device's external surface when oriented as described in paragraph 3.4.1. At least one temperature sensor shall be located at the centre of Tested-Device, and at least four temperature sensors shall be located within 10 cm from the edge of the Tested-Device towards its centre with nearly equal distance between the sensors.
- 3.4.5. The bottom of Tested-Device shall be exposed to the even flame directly and entirely by fuel combustion. LPG burner flame shall exceed the horizontal projection of the Tested-Device by at least 20 cm.
- 3.4.6. An average temperature of 800 °C shall be reached within 30 seconds and maintained between 800°C and 1,100°C. The Tested-Device shall then be exposed to the flame for 2 minutes.

- 3.4.7. After direct exposure to flame the Tested-Device shall be observed until such time as the surface temperature of the Tested-Device has decreased to ambient temperature or has been decreasing for a minimum of 3 hours.

Annex 9E - Appendix 1

Dimension and technical data of firebricks

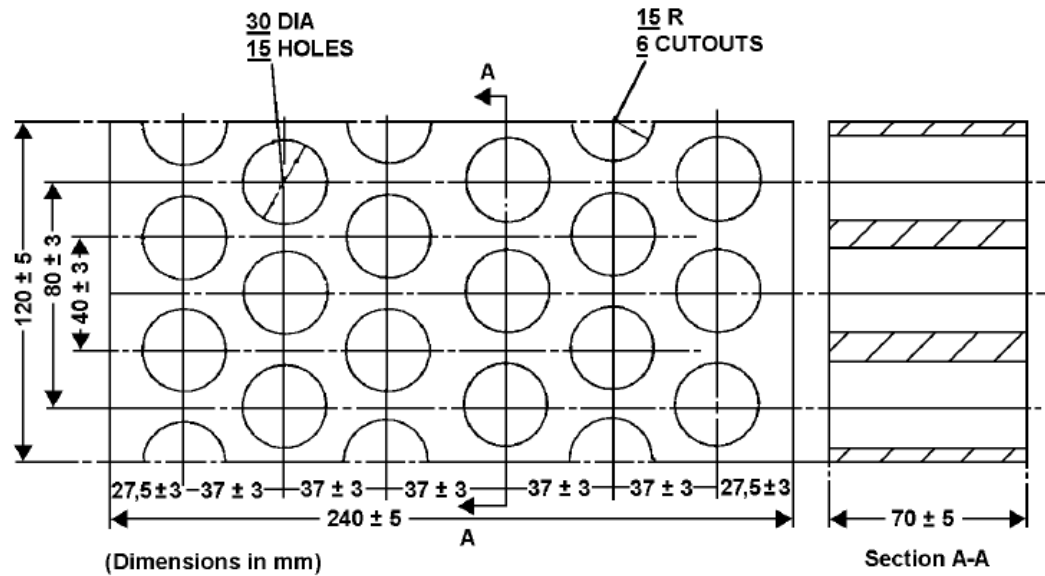

Fire resistance:	(Seger-Kegel) SK 30
Al ₂ O ₃ content:	30 - 33 per cent
Open porosity (Po):	20 - 22 per cent vol.
Density:	1,900 - 2,000 kg/m ³
Effective holed area:	44.18 per cent

Annex 9F

External short circuit protection

1. Purpose

The purpose of this test is to verify the performance of the short circuit protection to prevent the REESS from any further related severe events caused by short circuit current.

2. Installations

This test shall be conducted either with a complete vehicle or with the complete REESS or with the REESS subsystem(s). If the manufacturer chooses to test with REESS subsystem(s), the Tested-Device shall be able to deliver the nominal voltage of the complete REESS and the manufacturer shall demonstrate that the test result can reasonably represent the performance of the complete REESS with respect to its safety performance under the same conditions. If the electronic management unit for the REESS is not integrated in the casing enclosing the cells, then the electronic management unit may be omitted from installation on the Tested-Device if so requested by the manufacturer. For a test with a complete vehicle, the manufacturer may provide information to connect a breakout harness to a location just outside the REESS that would permit applying a short circuit to the REESS.

3. Procedures

3.1. General test conditions

The following condition shall apply to the test:

- (a) The test shall be conducted at an ambient temperature of 20 ± 10 °C or at higher temperature if requested by the manufacturer;
- (b) At the beginning of the test, the SOC shall be adjusted in accordance with Annex 9, Appendix 2;
- (c) At the beginning of the test, all protection devices which would affect the function of the Tested-Device and which are relevant to the outcome of the test shall be operational.
- (d) For testing with a complete vehicle, a breakout harness is connected to the manufacturer specified location and vehicle protection systems relevant to the outcome of the test shall be operational.

3.2. Short circuit

At the start of the test all relevant main contactors for charging and discharging shall be closed to represent the active driving possible mode as well as the mode to enable external charging. If this cannot be completed in a single test, then two or more tests shall be conducted.

For testing with a complete REESS or REESS subsystem(s), the positive and negative terminals of the Tested-Device shall be connected to each other to produce a short circuit. The connection used for this purpose shall have a resistance not exceeding 5 mΩ.

For testing with a complete vehicle, the short circuit is applied through the breakout harness. The connection used for creating the short circuit (including the cabling) shall have a resistance not exceeding 5 mΩ.

The short circuit condition shall be continued until the protection function operation of the REESS terminate the short circuit current is confirmed, or for at least one hour after the temperature measured on the casing of the Tested-Device has stabilised, such that the temperature gradient varies by a less than 4 °C through 2 hour.

3.3. Standard cycle and observation period

Directly after the termination of the short circuit a standard cycle as described in Annex 9, Appendix 1 shall be conducted, if not inhibited by the Tested-Device.

The test shall end with an observation period of 1 h at the ambient temperature conditions of the test environment.

Annex 9G

Overcharge protection

1. Purpose

The purpose of this test is to verify the performance of the overcharge protection to prevent the REESS from any further related severe events caused by a too high SOC.

2. Installations

This test shall be conducted, under standard operating conditions, either with a complete vehicle or with the complete REESS Ancillary systems that do not influence the test results may be omitted from the Tested-Device.

The test may be performed with a modified Tested-Device these modifications shall not influence the test results.

3. Procedures

3.1. General test conditions

The following requirements and conditions shall apply to the test:

- (a) The test shall be conducted at an ambient temperature of 20 ± 10 °C or at higher temperature if requested by the manufacturer;
- (b) The SOC of REESS shall be adjusted around the middle of normal operating range by normal operation recommended by the manufacturer such as driving the vehicle or using an external charger. The accurate adjustment is not required as long as the normal operation of the REESS is enabled;
- (c) For vehicle-based test of vehicles with on-board energy conversion systems (e.g. internal combustion engine, fuel cell, etc.), fill the fuel to allow the operation of such energy conversion systems;
- (d) At the beginning of the test, all protection devices which would affect the function of the Tested-Device and which are relevant to the outcome of the test shall be operational. All relevant main contactors for charging shall be closed.

3.2. Charging

The procedure for charging the REESS for vehicle-based test shall be in accordance with paragraphs 3.2.1. and 3.2.2. and shall be selected as appropriate for the relevant mode of vehicle operation and the functionality of the protection system. Alternatively, the procedure for charging the REESS for vehicle-based test shall be in accordance with paragraph 3.2.3. For component-based test, the charging procedure shall be in accordance with paragraph 3.2.4.

3.2.1. Charge by vehicle operation.

This procedure is applicable to the vehicle-based tests in active driving possible mode:

- (a) For vehicles that can be charged by on-board energy sources (e.g. energy recuperation, on-board energy conversion systems), the vehicle shall be driven on a chassis dynamometer. The vehicle operation on a chassis dynamometer (e.g. simulation of continuous down-hill driving) that will deliver as high charging current as reasonably

achievable shall be determined, if necessary, through consultation with the manufacturer.

- (b) The REESS shall be charged by the vehicle operation on a chassis dynamometer in accordance with paragraph 3.2.1.(a). The vehicle operation on the chassis dynamometer shall be terminated when the vehicle's overcharge protection controls terminates the REESS charge current or the temperature of the REESS is stabilized such that the temperature varies by a gradient of less than 2 °C through 1 hour. Where an automatic interrupt function vehicle's overcharge protection control fails to operate, or if there is no such control function, the charging shall be continued until the REESS temperature reaches 10 °C above its maximum operating temperature specified by the manufacturer.
- (c) Immediately after the termination of charging, one standard cycle as described in Annex 9, Appendix 1 shall be conducted, if it is not prohibited by the vehicle, with vehicle operation on a chassis dynamometer.

3.2.2. Charge by external electricity supply (vehicle-based test).

This procedure is applicable to vehicle-based test for externally chargeable vehicles:

- (a) The vehicle inlet for normal use, if it exists, shall be used for connecting the external electricity supply equipment. The charge control communication of the external electricity supply equipment shall be altered or disabled to allow the charging specified in paragraph 3.2.2.(b) below;
- (b) The REESS shall be charged by the external electricity supply equipment with the maximum charge current specified by the manufacturer. The charging shall be terminated when the vehicle's overcharge protection control terminates the REESS charge current. Where vehicle's overcharge protection control fails to operate, or if there is no such control, the charging shall be continued until the REESS temperature reaches 10 °C above its maximum operating temperature specified by the manufacturer. In the case where charge current is not terminated and where the REESS temperature remains less than 10 °C above the maximum operating temperature, vehicle operation shall be terminated 12 hours after the start of charging by external electricity supply equipment;
- (c) Immediately after the termination of charging, one standard cycle as described in Annex 9, Appendix 1 shall be conducted, if it is not prohibited by the vehicle, with vehicle operation on a chassis dynamometer for discharging and with external electricity supply equipment for charging.

3.2.3. Charge by connecting breakout harness (vehicle-based test).

This procedure is applicable to vehicle-based tests for both externally chargeable vehicles and vehicles that can be charged only by on-board energy sources and for which the manufacturer provides information to connect a breakout harness to a location just outside the REESS that permits charging of the REESS:

- (a) The breakout harness is connected to the vehicle as specified by the manufacturer. The trip current/voltage setting of the external charge-discharge equipment shall be at least 10 per cent higher than the current/voltage limit of the Tested-Device. The external electricity

supply equipment is connected to the breakout harness. The REESS shall be charged by the external electricity power supply with the maximum charge current specified by the manufacturer;

- (b) The charging shall be terminated when the vehicle's overcharge protection control terminates the REESS charge current. Where vehicle's overcharge protection control fails to operate, or if there is no such control, the charging shall be continued until the REESS temperature is 10 °C above its maximum operating temperature specified by the manufacturer. In the case where charge current is not terminated and where the REESS temperature remains less than 10 °C above the maximum operating temperature, vehicle operation shall be terminated 12 hours after the start of charging by external electricity supply equipment;
- (c) Immediately after the termination of charging, one standard cycle as described in Annex 9, Appendix 1 (for a complete vehicle) shall be conducted, if it is not prohibited by the vehicle.

3.2.4. Charge by external electricity supply (component-based test).

This procedure is applicable to component-based test:

- (a) The external charge/discharge equipment shall be connected to the main terminals of the REESS. The charge control limits of the test equipment shall be disabled;
- (b) The REESS shall be charged by the external charge/discharge equipment with the maximum charge current specified by the manufacturer. The charging shall be terminated when the REESS overcharge protection control terminates the REESS charge current. Where overcharge protection control of the REESS fails to operate, or if there is no such control, the charging shall be continued until the REESS temperature reaches 10 °C above its maximum operating temperature specified by the manufacturer. In the case where charge current is not terminated and where the REESS temperature remains less than 10 °C above the maximum operating temperature, the charging shall be terminated 12 hours after the start of charging by external electricity supply equipment;
- (c) Immediately after the termination of charging, one standard cycle as described in Annex 9, Appendix 1 shall be conducted, if it is not prohibited by the REESS, with external charge-discharge equipment.

3.3. The test shall end with an observation period of 1 hour at the ambient temperature conditions of the test environment.

Annex 9H

Over-discharge protection

1. Purpose

The purpose of this test is to verify the performance of the over-discharge protection to prevent the REESS from any severe events caused by a too low SOC.
2. Installations

This test shall be conducted, under standard operating conditions, either with a complete vehicle or with the complete REESS. Ancillary systems that do not influence the test results may be omitted from the Tested-Device.

The test may be performed with a modified Tested-Device provided these modifications shall not influence the test results.
3. Procedures
 - 3.1. General test conditions

The following requirements and condition shall apply to the test:

 - (a) The test shall be conducted at an ambient temperature of 20 ± 10 °C or at higher temperature if requested by the manufacturer;
 - (b) The SOC of REESS shall be adjusted at the low level, but within normal operating range, by normal operation recommended by the manufacturer, such as driving the vehicle or using an external charger. Accurate adjustment is not required as long as the normal operation of the REESS is enabled;
 - (c) For vehicle-based test of vehicles with on-board energy conversion systems (e.g. internal combustion engine, fuel cell, etc.), reduce the electrical energy from such on-board energy conversion systems, for example by adjusting the fuel level to nearly empty but enough so that the vehicle can enter into active driving possible mode;
 - (d) At the beginning of the test, all protection devices which would affect the function of the Tested-Device and which are relevant for the outcome of the test shall be operational.
 - 3.2. Discharging

The procedure for discharging the REESS for vehicle-based test shall be in accordance with paragraphs 3.2.1. and 3.2.2. Alternatively, the procedure for discharging the REESS for vehicle-based test shall be in accordance with paragraph 3.2.3. For the component-based test, the discharging procedure shall be in accordance with paragraph 3.2.4.

 - 3.2.1. Discharge by vehicle driving operation.

This procedure is applicable to the vehicle-based tests in active driving possible mode:

 - (a) The vehicle shall be driven on a chassis dynamometer. The vehicle operation on a chassis dynamometer (e.g. simulation of continuous driving at steady speed) that will deliver as constant discharging power as reasonably achievable shall be determined, if necessary, through consultation with the manufacturer;

- (b) The REESS shall be discharged by the vehicle operation on a chassis dynamometer in accordance with paragraph 3.2.1.(a). The vehicle operation on the chassis dynamometer shall be terminated when the vehicle's over-discharge protection control terminates REESS discharge current or the temperature of the REESS is stabilized such that the temperature varies by a gradient of less than 4 °C through 2 hours. Where an over-discharge protection control fails to operate, or if there is no such control, then the discharging shall be continued until the REESS is discharged to 25 per cent of its nominal voltage level;
- (c) Immediately after the termination of discharging, one standard charge followed by a standard discharge as described in Annex 9, Appendix 1 shall be conducted if it is not prohibited by the vehicle.

3.2.2. Discharge by auxiliary electrical equipment (vehicle-based test).

This procedure is applicable to the vehicle-based tests in stationary condition:

- (a) The vehicle shall be switched in to a stationary operation mode that allow consumption of electrical energy from REESS by auxiliary electrical equipment. Such an operation mode shall be determined, if necessary, through consultation with the manufacturer. Equipment (e.g. wheel chocks) that prevent the vehicle movement may be used as appropriate to ensure the safety during the test;
- (b) The REESS shall be discharged by the operation of electrical equipment, air-conditioning, heating, lighting, audio-visual equipment, etc., that can be switched on under the conditions given in paragraph 3.2.2.(a). The operation shall be terminated when the vehicle's over-discharge protection control terminates REESS discharge current or the temperature of the REESS is stabilized such that the temperature varies by a gradient of less than 4 °C through 2 hours. Where an over-discharge protection control fails to operate, or if there is no such control, then the discharging shall be continued until the REESS is discharged to 25 per cent of its nominal voltage level;
- (c) Immediately after the termination of discharging, one standard charge followed by a standard discharge as described in Annex 9, Appendix 1 shall be conducted if it is not prohibited by the vehicle.

3.2.3. Discharge of REESS using discharge resistor (vehicle-based test).

This procedure is applicable to vehicles for which the manufacturer provides information to connect a breakout harness to a location just outside the REESS that permits discharging the REESS:

- (a) Connect the breakout harness to the vehicle as specified by the manufacturer. Place the vehicle in active driving possible mode;
- (b) A discharge resistor is connected to the breakout harness and the REESS shall be discharged at a discharge rate under normal operating conditions in accordance with manufacturer provided information. A resistor with discharge power of 1 kW may be used;
- (c) The test shall be terminated when the vehicle's over-discharge protection control terminates REESS discharge current or the temperature of the REESS is stabilized such that the temperature varies by a gradient of less than 4 °C through 2 hours. Where an automatic discharge interrupt function fails to operate, or if there is no such function, then the discharging shall be continued until the REESS is discharged to 25 per cent of its nominal voltage level;

- (d) Immediately after the termination of discharging, one standard charge followed by a standard discharge as described in Annex 9, Appendix 1 shall be conducted if it is not prohibited by the vehicle.

3.2.4. Discharge by external equipment (component-based test).

This procedure is applicable to component-based test:

- (a) All relevant main contactors shall be closed. The external charge-discharge shall be connected to the main terminals of the Tested-Device;
- (b) A discharge shall be performed with a stable current within the normal operating range as specified by the manufacturer;
- (c) The discharging shall be continued until the Tested-Device (automatically) terminates REESS discharge current or the temperature of the Tested-Device is stabilized such that the temperature varies by a gradient of less than 4 °C through 2 hours. Where an automatic interrupt function fails to operate, or if there is no such function, then the discharging shall be continued until the Tested-Device is discharged to 25 per cent of its nominal voltage level;
- (d) Immediately after the termination of the discharging, one standard charge followed by a standard discharge as described in Annex 9, Appendix 1 shall be conducted if not inhibited by the Tested-Device.

3.3. The test shall end with an observation period of 1 h at the ambient temperature conditions of the test environment.

Annex 9I

Over-temperature protection

1. Purpose

The purpose of this test is to verify the performance of the protection measures of the REESS against internal overheating during the operation. In the case that no specific protection measures are necessary to prevent the REESS from reaching an unsafe state due to internal over-temperature, this safe operation must be demonstrated.
2. The test may be conducted with a complete REESS according to paragraphs 3. and 4. or with a complete vehicle according to paragraphs 5. and 6.
3. Installation for test conducted using a complete REESS
 - 3.1. Ancillary systems that do not influence to the test results may be omitted from the Tested-Device. The test may be performed with a modified Tested-Device provided these modifications shall not influence the test results.
 - 3.2. Where a REESS is fitted with a cooling function and where the REESS will remain functional in delivering its normal power without a cooling function system being operational, the cooling system shall be deactivated for the test.
 - 3.3. The temperature of the Tested-Device shall be continuously measured inside the casing in the proximity of the cells during the test in order to monitor the changes of the temperature. The on-board sensor, if existing may be used with compatible tools to read the signal.
 - 3.4. The REESS shall be placed in a convective oven or climatic chamber. If necessary, for conducting the test, the REESS shall be connected to the rest of vehicle control system with extended cables. An external charge/discharge equipment may be connected under supervision by the vehicle manufacturer.
4. Test procedures for test conducted using a complete REESS.
 - 4.1. At the beginning of the test, all protection devices which affect the function of the Tested-Device and are relevant to the outcome of the test shall be operational, except for any system deactivation implemented in accordance with paragraph 3.2. above.
 - 4.2. The Tested-Device shall be continuously charged and discharged by the external charge/discharge equipment with a current that will increase the temperature of cells as rapidly as possible within the range of normal operation as defined by the manufacturer until the end of the test.

Alternatively, the charge and discharge may be conducted by vehicle driving operations on chassis dynamometer where the driving operation shall be determined through consultation with the manufacturer to achieve the conditions above.
 - 4.3. The temperature of the chamber or oven shall be gradually increased, from 20 ± 10 °C or at higher temperature if requested by the manufacturer, until it reaches the temperature determined in accordance with paragraph 4.3.1. or 4.3.2. below as applicable, and then maintained at a temperature that is equal to or higher than this, until the end of the test.

- 4.3.1. Where the REESS is equipped with protective measures against internal overheating, the temperature shall be increased to the temperature defined by the manufacturer as being the operational temperature threshold for such protective measures, to ensure that the temperature of the Tested-Device will increase as specified in paragraph 4.2. above.
- 4.3.2. Where the REESS is not equipped with any specific measures against internal over-heating, the temperature shall be increased to the maximum operational temperature specified by the manufacturer.
- 4.4. The end of test: The test will end when one of the followings is observed:
- (a) The Tested-Device inhibits and/or limits the charge and/or discharge to prevent the temperature increase;
 - (b) The temperature of the Tested-Device is stabilised, which means that the temperature varies by a gradient of less than 4 °C through 2 hours;
 - (c) Any failure of the acceptance criteria prescribed in paragraph 6.9.2.1. of the Regulation.
5. Installation for test conducted using a complete vehicle.
- 5.1. Based on information from the manufacturer, for a REESS fitted with a cooling function the cooling system shall be disabled or in a state of significantly reduced operation (for a REESS that will not operate if the cooling system is disabled) for the test.
- 5.2. The temperature of the REESS shall be continuously measured inside the casing in the proximity of the cells during the test to monitor the changes of temperature using on-board sensors and compatible tools according to manufacturer provided information for reading the signals.
- 5.3. The vehicle shall be placed in a climate control chamber set to a temperature between 40 °C to 45 °C for at least 6 hours.
6. Test procedures for test conducted using a complete vehicle.
- 6.1. The vehicle shall be continuously charged and discharged in a manner that will increase the temperature of REESS cells as rapidly as possible within the range of normal operation as defined by the manufacturer until the end of the test.
- The charge and discharge will be conducted by vehicle driving operations on chassis dynamometer where the driving operation shall be determined through consultation with the manufacturer to achieve the conditions above.
- For a vehicle that can be charged by an external power supply, the charging may be conducted using an external power supply if more rapid temperature increase is expected.
- 6.2. The test will end when one of the followings is observed:
- (a) The vehicle terminates the charge and/or discharge;
 - (b) The temperature of the REESS is stabilized such that the temperature varies by a gradient of less than 4 °C through 2 hours;
 - (c) Any failure of the acceptance criteria prescribed in paragraph 6.9.2.1. of the Regulation;
 - (d) Three hours elapse from the time of starting the charge/discharge cycles in paragraph 6.1.

Annex 9J

Over-current protection

1. Purpose

The purpose of this test is to verify the performance of the overcurrent protection during DC external charging to prevent the REESS from any severe events caused by excessive levels of charge current as specified by the manufacturer.
2. Test conditions:
 - (a) The test shall be conducted at an ambient temperature of 20 ± 10 °C;
 - (b) The SOC of REESS shall be adjusted around the middle of normal operating range by normal operation recommended by the manufacturer such as driving the vehicle or using an external charger. The accurate adjustment is not required as long as the normal operation of the REESS is enabled;
 - (c) The overcurrent level (assuming failure of external DC electricity supply equipment) and maximum voltage (within normal range) that can be applied shall be determined, if necessary, through consultation with the manufacturer.
3. The overcurrent test shall be conducted in accordance with paragraph 4. or paragraph 5., as applicable and in accordance with manufacturer information.
4. Overcurrent during charging by external electricity supply.

This test procedure is applicable to vehicle-based test for vehicles that have the capability of charging by DC external electricity supply:

 - (a) The DC charging vehicle inlet shall be used for connecting the external DC electricity supply equipment. The charge control communication of the external electricity supply equipment is altered or disabled to allow the overcurrent level determined through consultation with the manufacturer;
 - (b) Charging of the REESS by the external DC electricity supply equipment shall be initiated to achieve the highest normal charge current specified by the manufacturer. The charge current is then increased over 5 seconds from the highest normal charge current to the overcurrent level determined in accordance with paragraph 2.(c) above. Charging is then continued at this overcurrent level;
 - (c) The charging shall be terminated when the functionality of the vehicle's overcurrent protection terminates the REESS charge current or the temperature of the REESS is stabilized such that the temperature varies by a gradient of less than 4 °C through 2 hours;
 - (d) Immediately after the termination of charging, one standard cycle as described in Annex 9, Appendix 1 shall be conducted, if it is not prohibited by the vehicle.
5. Overcurrent during charging using breakout harness.

This test procedure is applicable to REESS for vehicles that have the capability of charging by DC external electricity supply and for which the manufacturer provides information to connect a breakout harness to a location just outside the REESS that permits charging of the REESS:

- (a) The breakout harness is connected to the vehicle or REESS as specified by the manufacturer;
 - (b) The external electricity supply equipment along with the overcurrent supply is connected to the breakout harness and charging of the REESS is initiated to achieve the highest normal charge current specified by the manufacturer;
 - (c) The charge current is then increased over 5 seconds from the highest normal charge current to the overcurrent level determined in accordance with paragraph 2.(c) above. Charging is then continued at this overcurrent level;
 - (d) The charging shall be terminated when the functionality of the vehicle's overcurrent protection terminates charging or the temperature of the Tested-Device is stabilized such that the temperature varies by a gradient of less than 4 °C through 2 hours;
 - (e) Immediately after the termination of charging, one standard cycle as described in Annex 9, Appendix 1 shall be conducted, if it is not prohibited by the vehicle.
6. The test shall end with an observation period of 1 hour at the ambient temperature conditions of the test environment.
-