



---

**Economic Commission for Europe****Inland Transport Committee****World Forum for Harmonization of Vehicle Regulations****Working Party on Passive Safety Provisions****Seventy-first session**

Geneva, 9–13 May 2022

Item 10 of the provisional agenda

**UN Regulation No. 129 (Enhanced Child Restraint Systems)****Proposal for Supplement 9 to the 01 series of amendments****Submitted by the expert from the European Association of Automotive Suppliers\***

The text reproduced below was prepared by the expert from the European Association of Automotive Suppliers (CLEPA) to amend UN Regulation No.129 to correct previous editing mistakes. The modifications to the current text of the UN Regulation are marked in bold for new or strikethrough for deleted characters.

---

\* In accordance with the programme of work of the Inland Transport Committee for 2022 as outlined in proposed programme budget for 2022 (A/76/6 (part V, sect. 20), para. 20.76), the World Forum will develop, harmonize and update UN Regulations in order to enhance the performance of vehicles. The present document is submitted in conformity with that mandate.

## I. Proposal

Annex 15, amend to read:

### "Annex 15

#### Description of Conditioning for Adjusters ~~connected to a strap~~

Figure 1  
Conditioning for adjusters mounted directly on Enhanced Child Restraint Systems

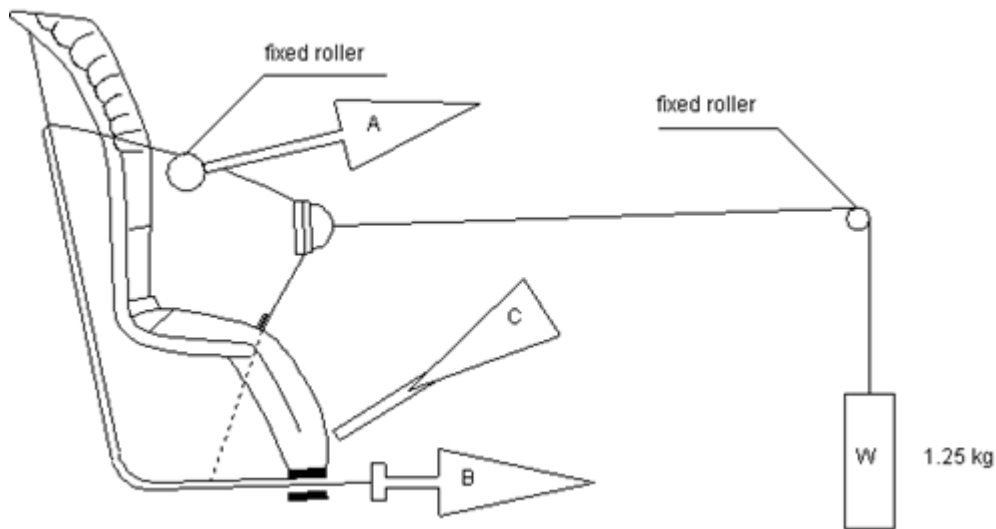

1. **Conditioning for adjusters mounted directly on Enhanced Child Restraint Systems (Figure 1)**
  - 1.1. **Method**
    - 1.1.1. With the webbing set at the reference position described in paragraph 7.2.6.1., withdraw at least 50 mm of webbing from the integral harness by pulling on the free end of the webbing.
    - 1.1.2. Attach the adjusted part of the integral harness to the pulling device A.
    - 1.1.3. Activate the adjuster and pull at least 150 mm of webbing into the integral harness. This represents half of one cycle and puts pulling device A to the maximum webbing extraction position.
    - 1.1.4. Connect free end of webbing to pulling device B.
  - 1.2. **The procedure of the cycle is:**
    - 1.2.1. Pull B at least 150 mm while A exerts no tension on the integral harness.
    - 1.2.2. Activate the adjusters and pull A while B exerts no tension on the free end of the webbing.
    - 1.2.3. At the end of stroke, de-activate the adjuster.
    - 1.2.4. Repeat cycle as specified in paragraph 6.7.2.7. of this UN Regulation.

**Figure 2**  
**Conditioning for adjusters connected to a strap (not directly mounted on Enhanced Child Restraint Systems)**

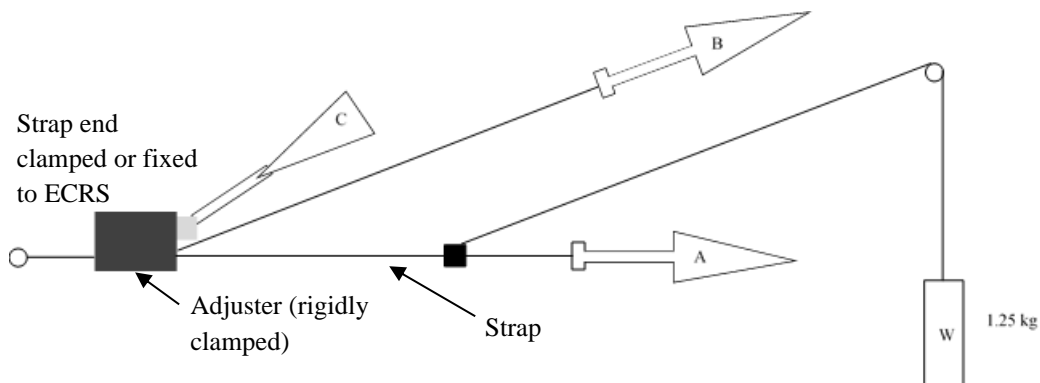

**2. Conditioning for adjusters connected to a strap (not directly mounted on Enhanced Child Restraint Systems) (Figure 2)**

**2.1. Method**

**2.1.1. Rigidly clamp the adjuster**

**2.1.2.** With the strap set at the reference position described in paragraph 7.2.6.2., withdraw at least 50 mm of strap from the adjuster by pulling on the free end of the strap.

**2.1.3.** Attach the adjuster part of the strap to the pulling device A.

**2.1.4.** Activate the adjuster (C) and pull at least 150 mm of strap through the adjuster. This represents half of one cycle and puts pulling device A to the maximum strap extraction position.

**2.1.5.** Connect the free end of the strap to pulling device B.

**2.2. The cycle is:**

**2.2.1.** Pull B at least 150 mm while A does not exert tension on the strap.

**2.2.2.** Activate the adjuster (C) and pull A while B does not exert tension on the free end of the strap.

**2.2.3.** At the end of the stroke, de-activate the adjuster.

**2.2.4.** Repeat the cycle as specified in paragraph 6.7.2.7. of this Regulation."

## II. Justification

This amendment to Annex 15 corrects an editing mistake that was made in proposals adopted at the sixty-first session of the Working Party on Passive Safety and subsequently entered into force in the 01 and 02 series of amendments to UN Regulation No. 129. Specifically, it reinstates a figure and procedure for testing adjusters mounted directly on the Enhanced Child Restraint System, which was mistakenly overwritten, instead of added to, by a figure and procedure for testing adjusters connected to a strap.