

Guideline for the application of footnote 3 of ADR 6.8.2.1.18 applicable as from 1 January 2021

In order to provide safe construction for the safe use of tanks in accordance with footnote 3 of ADR 6.8.2.1.18 in respect of the cross-sectional shapes of shells according to ADR 6.8.2.1.14 (a), the requirements in clause 6.1 of the forthcoming standard EN 13094:2020 to be referenced in ADR 6.8.2.6.1 are reproduced below for the purpose of the design and construction of tanks according to ADR 6.8.2.1.14 (a):

1. Shell cross section

1.1 General

A shell may have a circular, elliptical or other cross-section shape (including box-shaped) or combinations thereof.

Where a combination of shapes is used for a cross section, the required minimum thickness for the whole cross section at that point according to annex 1 shall be the greatest minimum thickness required for the shapes used.

1.2 Requirements for shells of non-circular cross section

(a) The radius of convexity of the shell wall shall not exceed 2 m at the sides and 3 m radius at the top and the bottom;

(b) There shall be a minimum radius of 200 mm linking the top/bottom and side convexities.

NOTE: The equivalent diameter for a non-circular section shall be calculated using the formula $D = 2\sqrt{\frac{St}{\pi}}$ where St = the internal cross-sectional area of the shell.

1.3 Sumps and other projections outside the shell

1.3.1 Projections outside the basic cross-section of a shell shall be kept to a minimum and protection shall be provided from all directions on the shell unless it is provided by vehicle components (e.g. chassis members, suspension components, axles, etc.). The cross-sectional area of each projection shall not exceed 10% of the cross-sectional area of the shell at that point without the projection. When the projection is not protected, the thickness shall not be less than the thickness specified for the shell given in annex 1. When the projection is protected, the thickness shall be the same thickness as the shell.

1.3.2 Shells and their compartments may be provided with sumps and/or internal channelling in order to:

- Assist the complete discharge of the substance carried;
- Facilitate the removal of entrained water from the substance carried; or
- Locate a foot valve away from an area where there exists a risk of damage, for example near the coupling section on a semi-trailer.

Sumps shall not protrude more than 150 mm from the contour of the shell.

Internal channelling and sumps shall be manufactured from the same material as the shell to which they are fitted; flat material may be used. Their minimum thickness shall be at least equal to that of the shell.

A sump may consist of a vertical cylindrical section combined with internal or external channelling sections to lower the mounting flange of the foot valve.

1.4 Cut-out sections within the contour of a side or bottom of the shell

1.4.1 Side cut-outs to accommodate service equipment

Side cut-outs to provide space for service equipment such as flow meters shall be designed in accordance with the following criteria:

- The total cross-sectional area of cut-outs at any point shall not exceed 20 % of the total cross-sectional area of the shell without cut-outs where the cut-outs are located;
- The length of the cut-out shall not exceed 40% of the length of the shell and in any case not exceed 1 400 mm;
- The minimum distance from the sides of the cut-outs to the ends shall be at least 200 mm;
- The height and depth of the cut-out shall be such that it does not encroach within 50 mm of the centre lines of the shell;
- The thickness shall not be less than the thickness specified in annex 1;
- The welds shall be fully penetrated (or made of lap joints);
- The cut-out shall not extend beyond one compartment or a section of shell.

See figures in annex 2 for examples of side cut outs.

1.4.2 Cut-outs to accommodate tank mountings or other structural equipment

Cut-outs to accommodate structural equipment (e.g. couplings for trailers or semi-trailers), shall be designed in accordance with the following criteria:

- The cross-sectional area of the cut-out shall not exceed 30% of the total cross-sectional area of the shell without cut-out, where it is located;
- The length of the cut-out shall not exceed 35% of the length of the tank;
- Service equipment shall not be welded directly to a concave surface within the cut-out;
- The weld shall be fully penetrated;
- The minimum thickness shall not be less than the thickness specified in annex 1;
- The joint of the end of the structural plate to the shell shall be to a partition or surge plate whose design complies with that for an end;
- The design shall not compromise complete drainage of the product to be carried.

See figure in annex 3 for an example of a bottom cut out.

Annex 1

Clause 6.8.1 from the forthcoming standard EN 13094:2020

Minimum shell thickness

The thickness of shells made of mild steel (with a guaranteed minimum tensile strength of 360 N/mm² to 490 N/mm²) shall be not less than the following values, unless the conditions specified in the clause in EN 13094 that concerns the “reduction of shell thickness” are met:

- 5 mm if the shell diameter is not more than 1.8 m;
- 6 mm if the shell diameter is greater than 1.8 m (except in the case of shells intended for the carriage of powdery or granulated substances).

For non-circular shells, an equivalent diameter shall be calculated on the basis of the cross-sectional area. For shells with sections having different cross-sectional areas, equivalent diameters shall be calculated for each section.

For tapered shells, the largest diameter or largest equivalent diameter of the section shall be used to calculate the minimum thickness of the shell section.

If the shell is made of another material, the equivalent minimum thickness shall be determined in accordance with Formula (3):

$$e_1 = \frac{464e_0}{\sqrt[3]{(R_{m1}A_1)^2}}$$

If the shell thickness is increased to allow for corrosive substances, this additional thickness shall not be taken into consideration in calculating the minimum shell thickness.

The actual minimum thickness shall not be below the absolute minimum shown in the table in ADR 6.8.2.1.19.

Annex 2

Examples of side cut outs

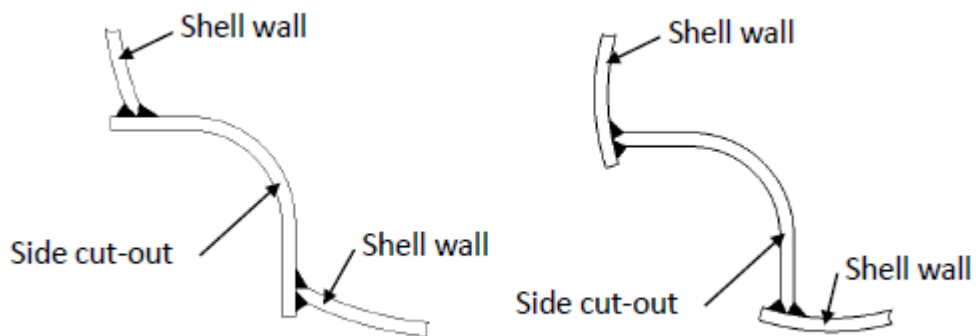

Annex 3

Examples of a bottom cut out

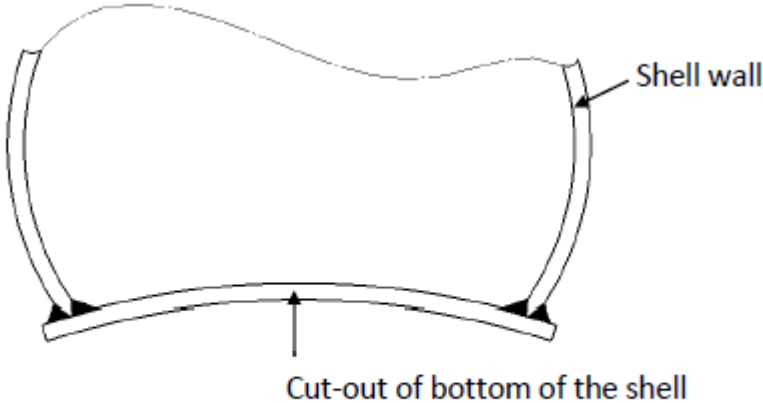

(Reference document: ECE/TRANS/WP.15/248, Annex II)
