

Proposal for Supplement 2 to the 06 series of amendments of UN Regulation No. 22 (Protective helmets)

Submitted by the experts from the [Ad Hoc Group of Interested Experts on Accessories for Protective Helmets under UN Regulation No.22 (APH-UNREG22)]

The text reproduced below was prepared Submitted by the experts from the [Ad Hoc Group of Interested Experts on Accessories for Protective Helmets under UN Regulation No.22] aiming to introduce some corrigendum to the approved proposal. Modifications to document ECE/TRANS/WP.29/2021/24e are marked in bold for new or strikethrough for deleted characters.

I.Proposal

Paragraph 5.4.4.1.2.2.1., amend to read:

5.4.4.1.2.2.1. For universal accessory, a dash and one or various symbols as applicable:

For components

"S" or "S45": "S" if the universal accessory include speakers whose maximum diameter is 40 mm or "S45" if the universal accessory include speakers whose maximum diameter is between 40 and 45 mm.

"M" if the universal accessory include microphone

For locations:

"F" if the universal accessory is to be installed or has a component to be installed in the front side area of the helmet

"L" if the universal accessory is to be installed or has a component to be installed in the side and

"R" if the universal accessory is to be installed or has a component to be installed in the rear area of the helmet

If an accessory has different components which need to be fitted in different locations of the helmet, be it "F","L" and/or "R", the location markings will be put into brackets and separated among them by a "+" symbol.

Insert a new paragraph 6.19.11., to read:

6.19.11. If an accessory can be mounted in different locations in a helmet and for this needs different supports, each of the supports shall bear an indelible mark with one of the following symbols:

"FR" For Front Right side fitting

“FL” For Front Left side fitting

“LR” For side Right fitting

“LL” For side Left fitting

“R” For rear fitting

The marking will be done in a visible surface when the support is attached to the helmet.

The markings will be of at least 8 mm height

Paragraph 14.1., amend to read:

“14.1. ...

“Does not protect chin from impacts” together with the symbol indicating the unsuitability of the lower face cover to offer any protection against impacts to the chin.

If the helmet is ready for accessories:

A clear description on where to install the accessories by using the reference mark or marks of paragraph 6.3. as well as clear indications on how to fit the speakers and/or microphone or any other component if it is the case.

A general warning shall be given to the user concerning the danger of making any alterations or additions to the helmet or visor, without the approval of the Type Approval Authority, that may decrease safety for the user.

A general warning shall be given to the user concerning the danger of fitting non homologated accessories. Only homologated accessories will maintain the helmet safety.

A general warning shall be given to the user stating that no accessory shall be mounted on the helmet if some of the symbols, **other than location fitting symbols**, marked in the accessory homologation is not marked in the helmet homologation label.

For location fitting symbols, “F”, “L” and “R”, a universal accessory will be able to be fitted if it is supplied with a support or supports marked with helmet available accessories fitting locations. The support used shall match the helmet location used. The support marking will add, after the “F” and “R” marking of fitting locations, the symbols “R”, if it has to be fitted on the right side of the helmet, or “L” if it has to be fitted on the left side of the helmet.

When the accessory has different components to be fitted in different helmet locations, accessory locations marking between brackets and with a “+” symbol in between location markings, the helmet shall bear all the accessory locations marking displayed between brackets.

Paragraph 14.8., amend to read:

“14.8. Every universal accessory placed on the market shall be accompanied by information in the national language, or in at least one of the national languages, of the country of destination.

This information shall contain advice on how to install it in the suitable helmets and information on those aspects specified in paragraphs 14.6.1. to 14.6.2. The instructions shall refer to the helmet owner manual for the right installation place.

A general warning shall be given to the user stating that no accessory shall be mounted on helmets whose symbols, **other than location fitting symbols**, marked in the helmet homologation label do not include all the symbols marked in the accessory homologation label.

A warning shall be given to the user stating that:

- a) **For location fitting symbols, “F”, “L” and “R”, the accessory will be able to be fitted if it is supplied with a support or supports marked with helmet available accessories fitting locations. The support used shall match the helmet location used. The support marking is adding, after the “F” and “R” marking of fitting locations, the symbols “R”, if it has to be fitted on the right side of the helmet, or “L” if it has to be fitted on the left side of the helmet.**
- b) **When the accessory has different components to be fitted in different helmet locations, the accessory locations marking are between brackets and with a “+” symbol in between location markings, the helmet shall bear all the accessory locations marking displayed between brackets.**

A warning shall be given to the user both in the packaging and in the owners manual indicating the left or right mounting position possibilities of the accessory.

Annex 2C, amend to read:

“ Annex 2C **Example of the arrangement of the approval mark for an accessory**

Example of the arrangement of the approval mark for a universal accessory...

..... without any tool for checking.

Example of the arrangement of the approval mark for a universal accessory that will use two helmet locations

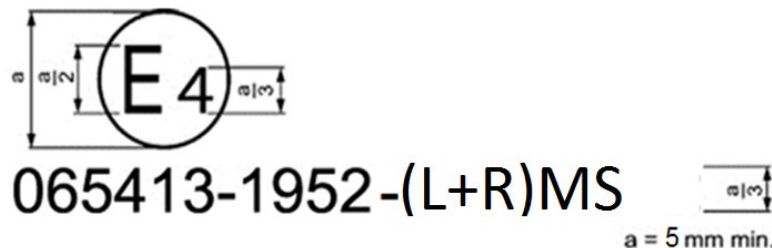

The above approval mark affixed to a universal accessory shows that the universal-accessory type concerned has been approved in the Netherlands (E 4) under approval number 065413. The approval number shows that approval was granted in accordance with the requirements of the Regulation incorporating the 06 series of amendments at the time of approval, that its production batch is 1952 and that is approved for Side and Rear mounting, each mounting position used by one accessory component, and has Microphone and Speakers.

Note: The approval number and the production batch number shall be placed close to the circle and either above or below the letter "E" or to the left or right of that letter. The digits of the approval number and of the production batch number shall be on the same side of the letter "E" and face the same direction. The use of Roman numerals as approval numbers should be avoided so as to prevent any confusion with other symbols.

Due to space restrictions, the approval number could be placed on the side of the accessory facing to the helmet provided that the accessory will have a support plate and that can be easily detachable without any tool for checking.

Example of the arrangement of the approval mark for a universal accessory that can use two helmet locations

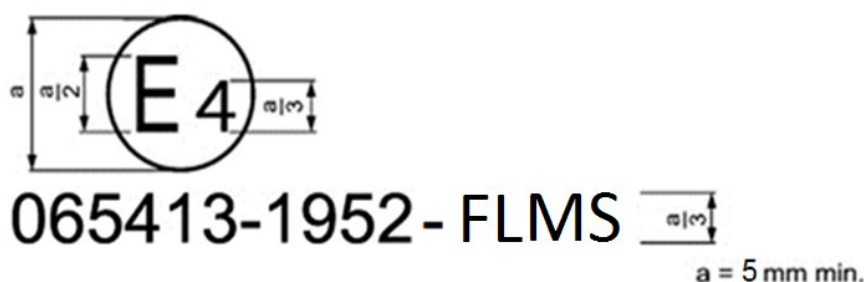

The above approval mark affixed to a universal accessory shows that the universal-accessory type concerned has been approved in the Netherlands (E 4) under approval number 065413. The approval number shows that approval was granted in accordance with the requirements of the Regulation incorporating the 06 series of amendments at the time of approval, that its production batch is 1952 and that is approved for Front or Side mounting and has Microphone and Speakers.

Note: The approval number and the production batch number shall be placed close to the circle and either above or below the letter "E" or to the left or right of that letter. The digits of the approval number and of the production batch number shall be on the same side of the letter "E" and face the same direction. The use of Roman numerals as approval numbers should be avoided so as to prevent any confusion with other symbols.

Due to space restrictions, the approval number could be placed on the side of the accessory facing to the helmet provided that the accessory will have a support plate and that can be easily detachable without any tool for checking.

Example of the arrangement of the approval mark for an specific accessory.....

..... that its production batch is 1952.”

Annex 8, amend figure 1d, to read:

"Figure 1d

Example of a helmet simulator for accessories projections and surface friction (method B)

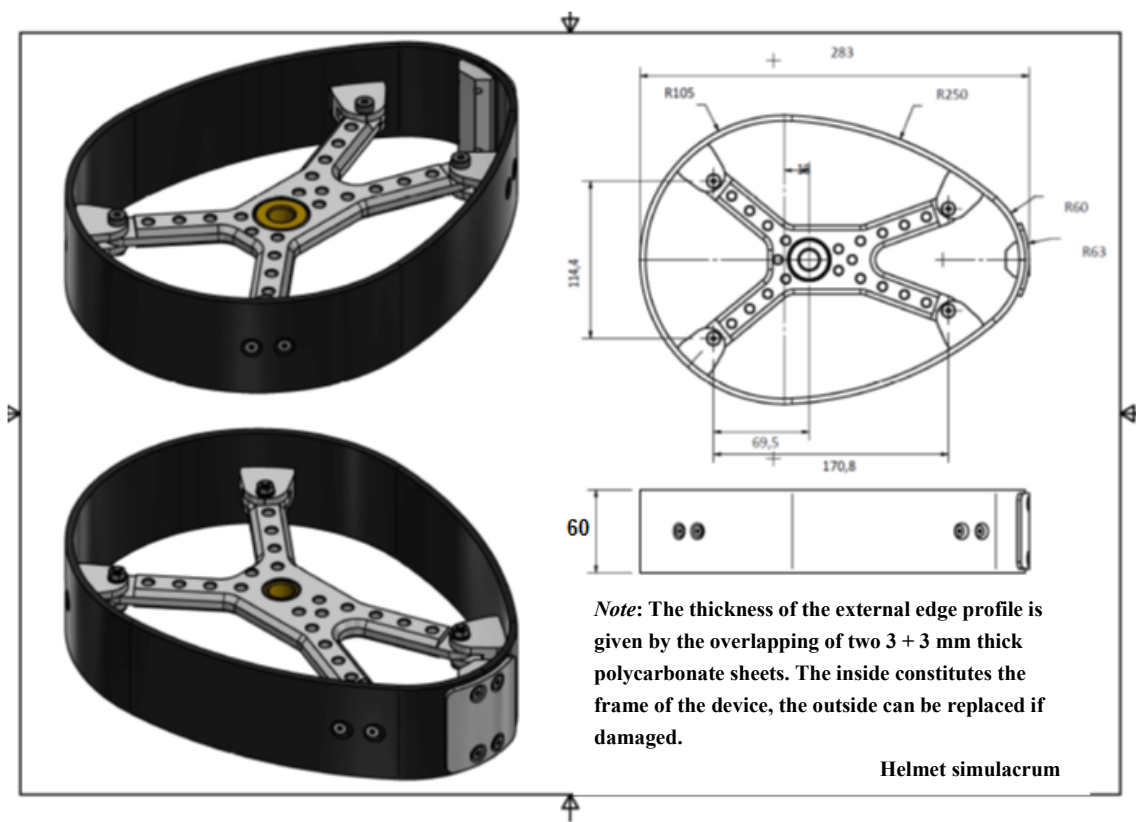

Annex 20, Part 1, paragraph 1.3., amend to read:

“1.3. Mechanical characterization of the speakers:

1.3.1. The speaker, with a height of more than 5 mm, shall be placed between two parallel plates by means of which a known load can be applied, the surface of the plates shall be large enough to contain a circle of at least 65 mm in diameter.

1.3.1.1. Procedure

The speaker shall be tested with all the foams, attachment films or layers.

The speaker is placed on the lower support of the universal traction machine.

The upper plate of the universal traction machine shall be brought closer to the test speaker without contact.

Set the zero force setting.

Bring the upper plate of the universal traction machine into contact with the speaker until the force reaches a value of 0.01 kN.

Measure the distance between the two supports.

Set the zero displacement setting.

Start the crush test at a constant speed of 10 mm/min. Record force vs distance at a minimum sampling rate of 10 Hz.

The test ends when the force reaches 10 kN.

The obtained chart for the speakers shall fall below the line defining the upper corridor limit.

Figure 4

Speakers quasi static crush test corridor

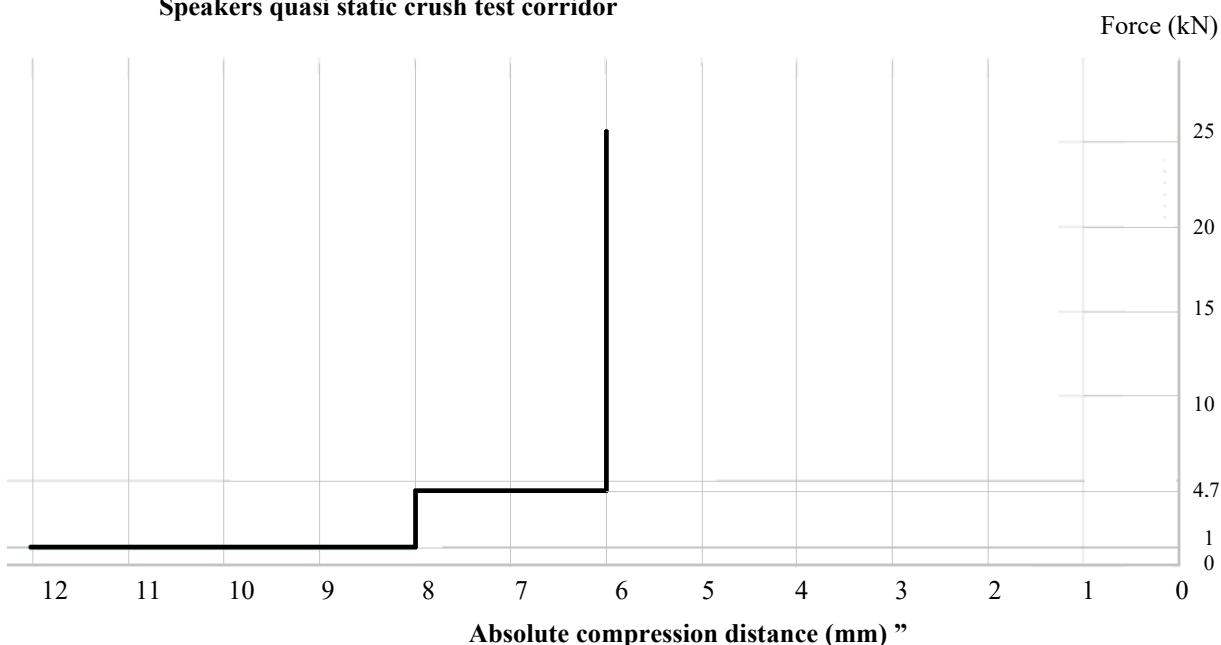

Annex 20, Part 1, paragraph 1.4.1. , amend to read:

1.4.1 Definition of deformable speaker simulator

1.4.1.1. Component and material specifications

The speaker simulator is illustrated in Figure 5 of this annex. The dimensions of the individual components of the speaker simulator are listed separately below. The below layers are a possible construction methodology, alternative possibilities are valid provided that they will fulfill the requirements of 1.4.1.3.

1.4.1.1.1. Layer 1: Headform facing sheet

Dimensions

Diameter: 40 mm
Tolerance: +0-1 mm
Thickness: 1 mm ± 0.07 mm

Material: Aluminium 5251/5052 (ISO 209, part 1)

1.4.1.1.2. Layer 2: Outer honeycomb block. Precrushed around 6mm.

Dimensions:

Diameter: 40 mm (in direction of honeycomb ribbon axis) L- and W-Direction
Tolerance: +0-1 mm
Depth: 6 mm (in direction of honeycomb cell axes)
Tolerance: ±0,1 mm
Material: Aluminium 3003 (ISO 209, Part 1)
Foil Thickness: 0.076 mm ± 15 per cent
Cell Size: 9.5 mm ± 20 per cent
Density: 57.7 kg/m³ ± 20 per cent
Crush Strength: 0.827 MPa ± 10 per cent

1.4.1.1.3. Layer 3: Intermediate bonding layer

Dimensions

Diameter: 40 mm
Tolerance: +0-1 mm
Thickness: 1 mm ± 0.07 mm
Material: Aluminium 5251/5052 (ISO 209, part 1)

1.4.1.1.4. Layer 4: Inner honeycomb block. Precrushed around 6mm.

Dimensions:

Diameter: 40 mm (in direction of honeycomb ribbon axis) L-and W-Direction
Tolerance: +0-1 mm
Depth: 3.4 mm (in direction of honeycomb cell axes)
Tolerance: ±0,1 mm
Material: Aluminium 5056 (ISO 209, Part 1)
Foil Thickness: 0.038 mm ± 15 per cent
Cell Size: 3.175 mm ± 20 per cent
Density: 97.71 kg/m³ ± 20 per cent
Crush Strength: 3.689 MPa ± 10 per cent

1.4.1.1.5. Layer 5: Backing sheet

Diameter: 40 mm/45 mm
Tolerance: +0-1 mm
Thickness: 1 mm ± 0.07 mm
Material: Aluminium 5251/5052 (ISO 209, part 1)

1.4.1.1.6. Adhesive

The adhesive to be used throughout should be a two-part polyurethane (such as Ciba-Geigy XB5090/1 resin with XB5304 hardener, or equivalent).

Figure 5

Speaker simulator

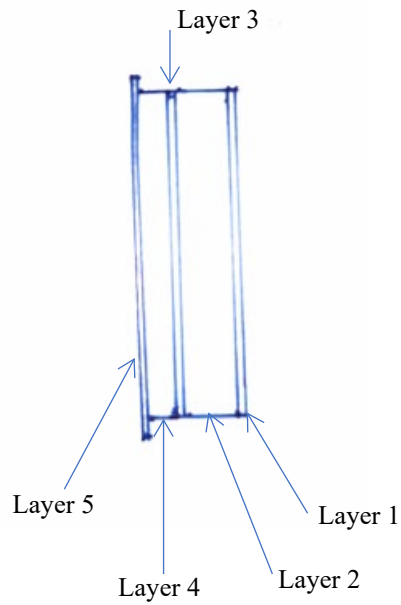

1.4.1.2. Aluminum honeycomb certification and simulator characterization

1.4.1.2.1. A certificate of the aluminium honeycomb performances will be necessary to ensure that the prescriptions of the above paragraph 1.4.1.1. will be fulfilled.

1.4.1.3. Simulator performance check

1.4.1.3.1. To ensure the proper behaviour of the speaker simulator, the TS shall ensure that the force-deformation curve will lay within the limits stated in Figure 6.

Figure 6

Speaker simulator force-deformation corridor

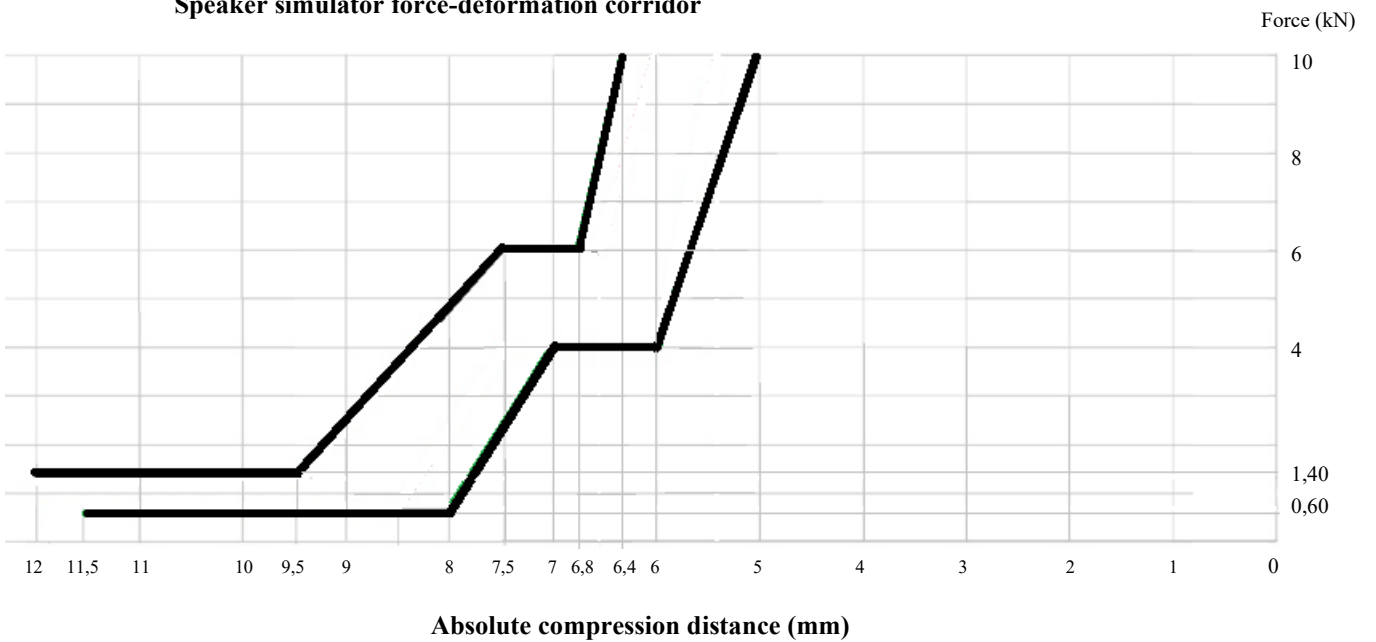

-
- 1.4.1.3.2. If the force-deformation curve of the simulator pass over the upper corridor limit or below the lower corridor limit by no more than 0,5 mm, the simulator is considered to pass.**
- 1.4.1.3.3. For every batch of simulators manufactured, the Technical Service will proceed to check that the performance of the simulator batch corresponds to the requirements of paragraph 1.4.1.3.1 and 1.4.1.3.2. above. The statistical method used for batch acceptance shall be filed by the TS.**
- 1.4.1.3.4. The testing procedure for the simulator will be the one defined in Annex 20, Part 1, paragraph 1.3.1.1.**
- 1.4.1.4. Precrush requirements for honeycomb parts**
- In order to avoid the first deformation peak force which is typical for honeycomb materials, a precrush of layer 2 and layer 4 described above will be necessary.**
- The dimensions laid down in paragrah 1 above for the honeycomb layers will be after precrush.**
- For layer 2, the initial thickness dimension of the honeycomb will be 12 mm.**
- For layer 4, the initial thickness dimension of the honeycomb will be 9 mm.**
- Precrushed side of Layer 2 shall be bonded to Layer 1.**
- Precrushed side of Layer 4 shall be bonded to Layer 3.**

Annex 20, Part 2, paragraph 2.1., change Figure 6 to read:

“Figure 7

Free protective padding space for accessories clamping for front and side locations of UA helmets

Helmet outer shell

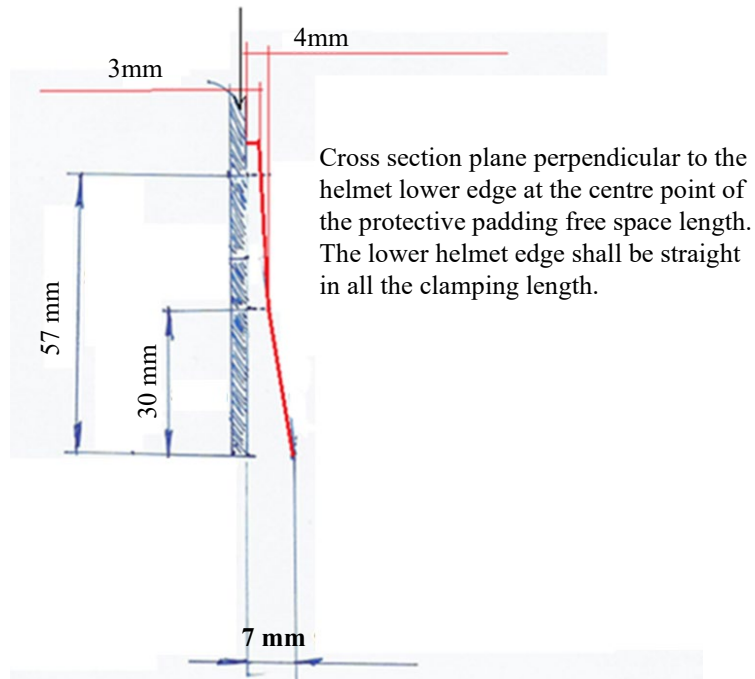

Annex 20, Part 2, paragraph 2.2. , amend to read:

- 2.2. Helmet clamping free space dimensions for rear mounting
- The helmet shall allow the insertion of metal sheets of 1 mm thickness and 55 mm height and 56 mm width, as one of the possible

Annex 20, Part 2, paragraph 2.3. , amend to read:

- 2.3. The bonding area, if protective padding clamping space is not provided by the helmet or if it is offered as alternative by the helmet manufacturer, shall be a continuous surface of convex curvature without or with a slight curvature radius in which a rectangle of minimum dimensions of 40 mm height by 80 mm length can be inserted.

II. Justification

1. Added an additional clarification on accessories marking when the same accessory can be fitted in F and L locations by using different supports. Also the need to mark the accessory to indicate if the accessory has components to be attached to different helmet locations at the same time is addressed for a better clarification to the user.
2. Added information to user manual to clarify point 1 above.
3. Added title in Annex 2C which has to mention marking for all accessories.
4. Addition of example markings in Annex 2C to clarify point 1 above.
5. Modified a measurement of helmet simulator, Annex 8, because of a typing mistake.
6. Modified testing method and limits for speakers characterization to be consistent with the new proposed deformable speaker simulator mechanical characteristics.

-
7. Modified definition of speaker simulator to introduce a deformable speaker simulator, which better represents the behaviour of actual speakers, to do a more realistic helmet test.
 8. Modified protective padding free space for accessories clamping because of a typing mistake.