

New regulation proposal on uniform provisions concerning the approval of devices and motor vehicles with regard to **the driver's awareness of vulnerable road users existing front and lateral side close-proximity of vehicles**

JAPAN,
on behalf of
VRU-Proxi Informal Working Group.

Background

Pedestrians account for 35.6% (1,258) of total fatalities in Japan (2018)

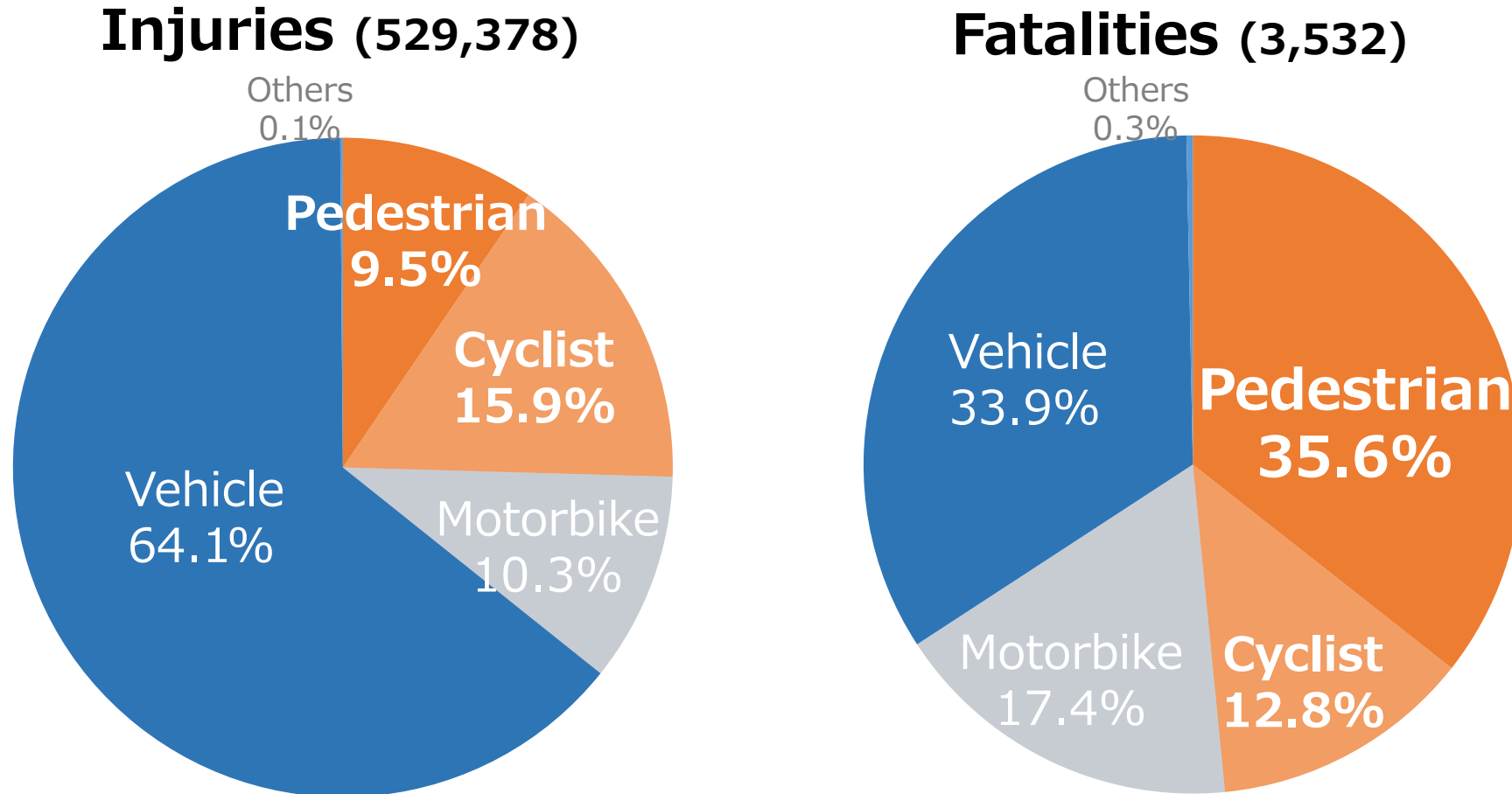

Source: 2018 Road traffic accident statics (National Police Agency)

Background

M1/N1 contributes to more than half of total fatalities and injuries among pedestrians, at low speed (below 20km/h).

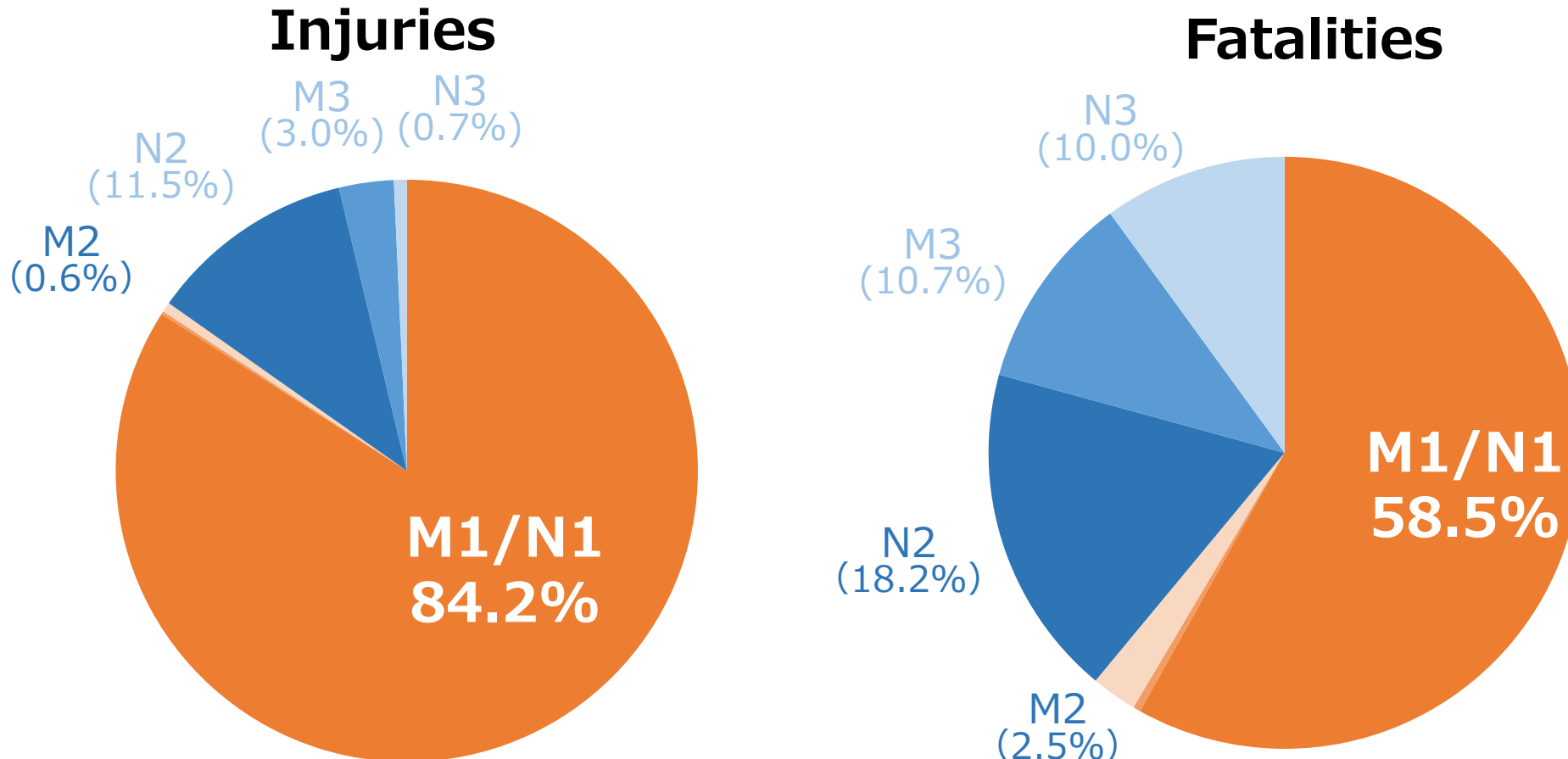

Source: Road traffic accident statics from 2014 to 2018 (5-year-accumulation) (ITARDA)

■ M1 and N1 ■ M2 ■ N2 ■ M3 ■ N3

Number of Injuries: 135,932 Number of fatalities : 998

Background

Over 30 percent of accidents occur while vehicle moving off or going straight at low speed (below 20km/h).

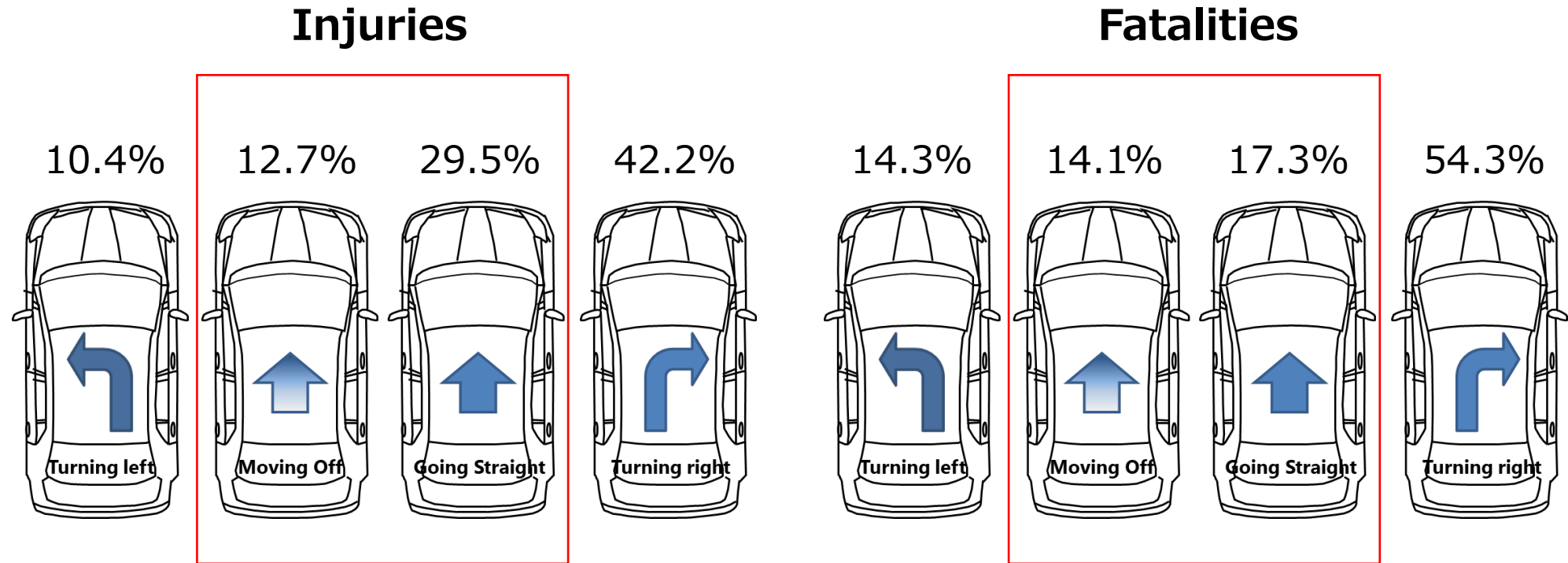

Source: Road traffic accident statics from 2014 to 2018 (5-year-accumulation) (ITARDA)
Number of Injuries: 125,471 Number of fatalities : 736 (*excluding other hitting points)

Background

Most of the hitting position is the front. But about 20% are side in the accidents occur while vehicle moving off or going straight at low speed (below 20km/h).

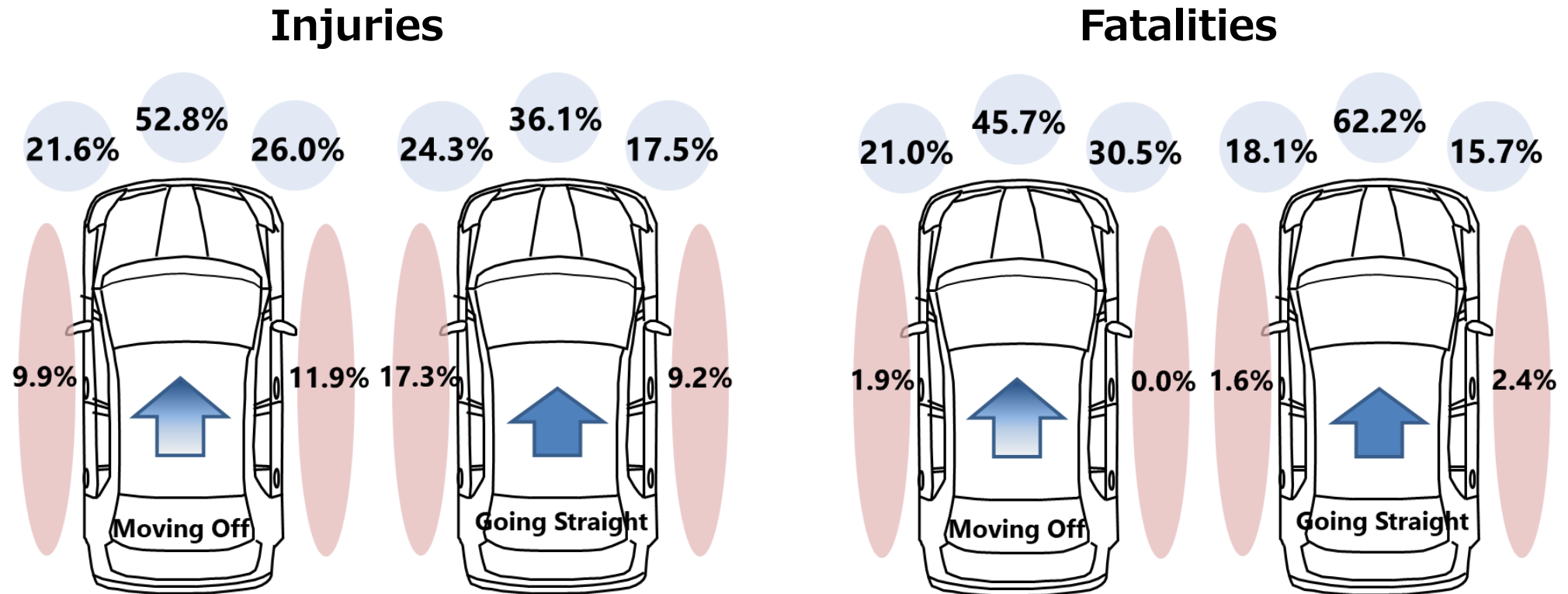

Source: Road traffic accident statics from 2014 to 2018 (5-year-accumulation) (ITARDA)
Number of Injuries: 15,939 Number of fatalities : 104 (*excluding other hitting points)

Proposal

Scope: M1 and N1

Vehicle Motion: moving off from stand-still

Detection Target: Pedestrians

Required Performance:

Driver's awareness of VRU around the vehicle close-proximity field of front and side before moving off.

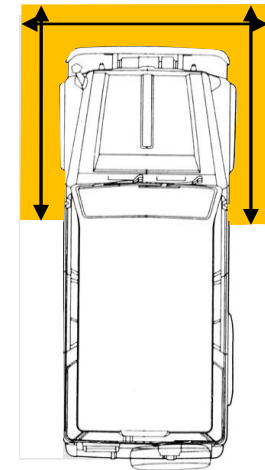

Requirements

Field of driver's front and lateral side close-proximity awareness

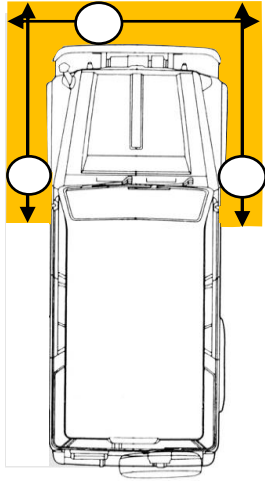

Any part of pole to be seen.

Means of driver's front close-proximity awareness

- Direct vision from adjusted driver's ocular point.
- Indirect vision (cameras, mirrors without periscope)
- Detection

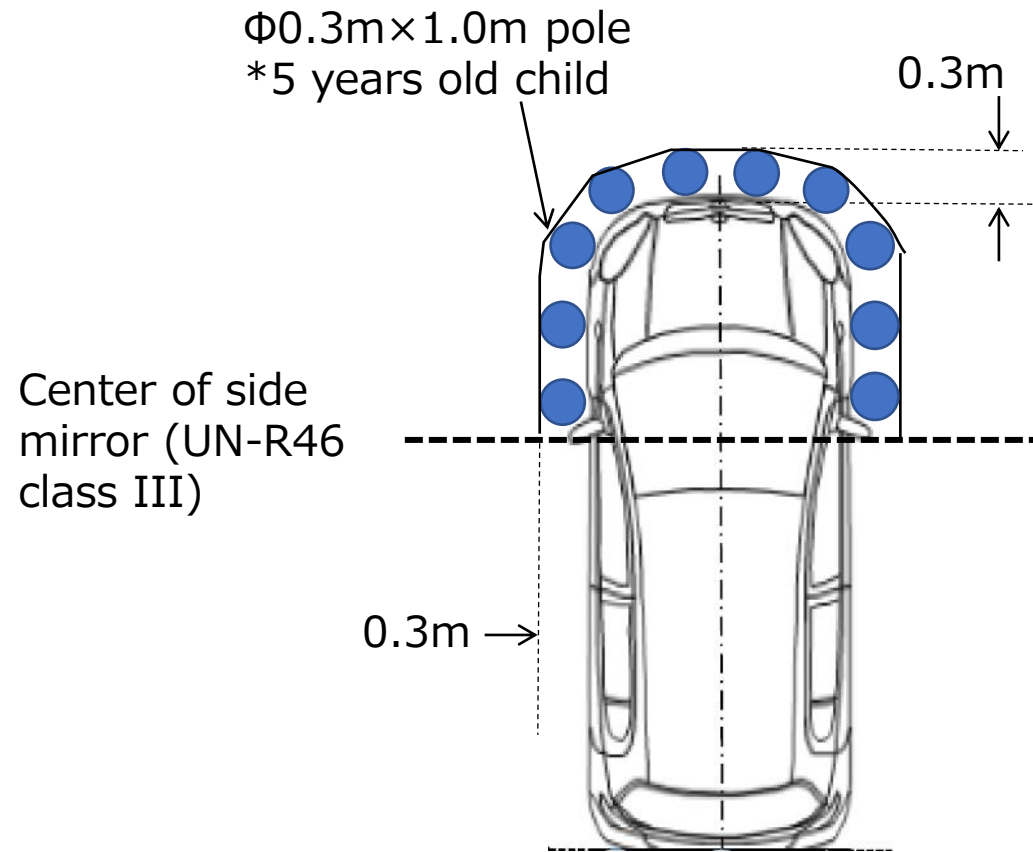

* When the class III mirror mounted in front of entire vehicle, field of vision is limited to the front side only.

Requirements

Direct vision

Any part of pole to be seen from adjusted driver's ocular point.

Methods of driver's ocular point adjustment

(1) Based on back angle *Same as R125

(2) Based on driver's stretching behavior (passenger's side and front side)

	Adjustment distance [mm]		
	Forward/rearward	Lateral	Upward/downward
Upward stretching	0	-10	40
Forward stretching	-140	-15	10
Lateral stretching	30	-110	15

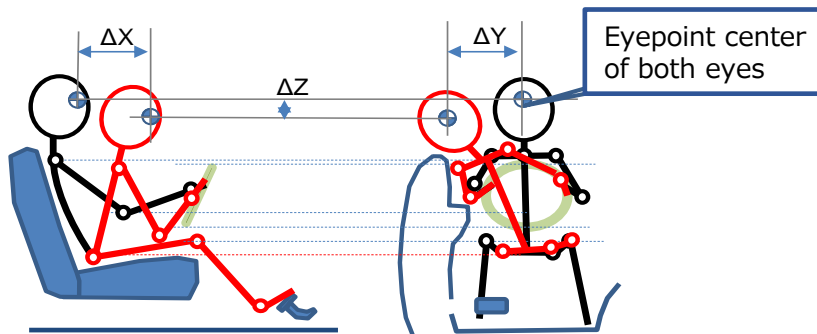

(3) Based on driver looks out of the side window (driver's side)

	Adjustment distance [mm]		
	Forward/rearward	Lateral	Upward/downward
Upward stretching	20	25	-5
Forward stretching	10	30	0
Lateral stretching	5	35	-5

* Adjustment values defined based on the subject measurements.

Requirements

Indirect vision

Any part of pole to be seen in the camera image or mirror surface.

Detection

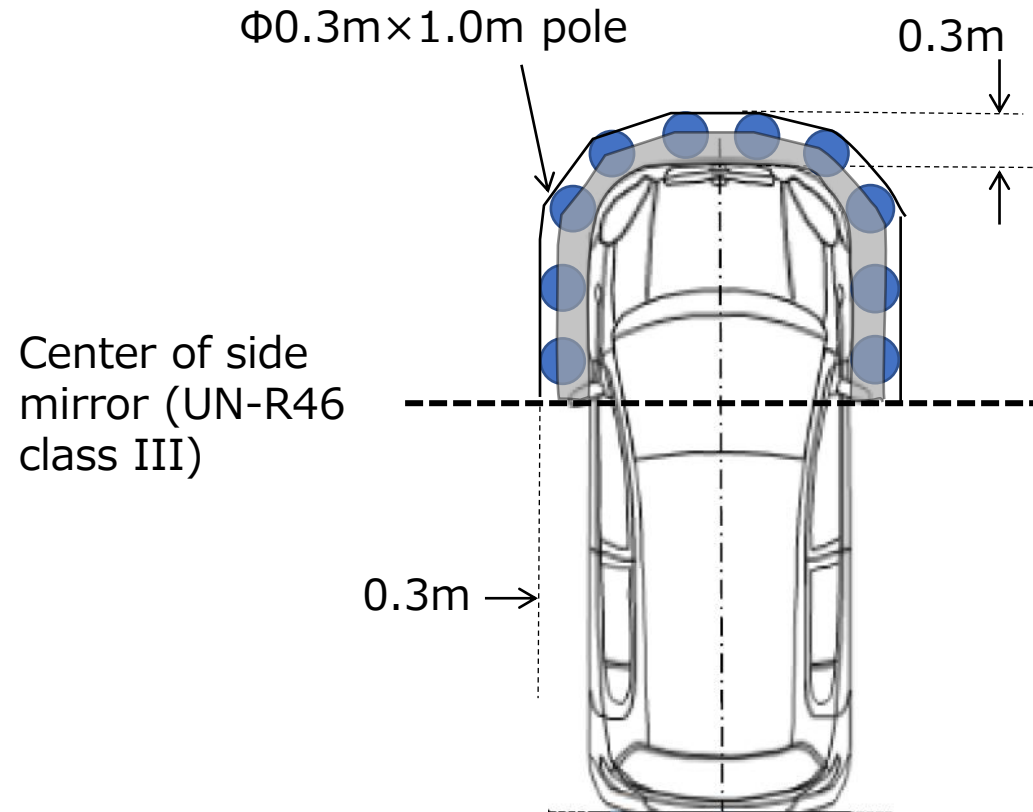

Detection needs 0.2m distance from vehicle.



Pole to be detected in the 0.1m range (rest of field of vision).

Requirements

Combination of several means for awareness

Close-proximity field of awareness shall be fully covered by the single or the combination of means for driver's awareness.

Example *Right-handed drive case

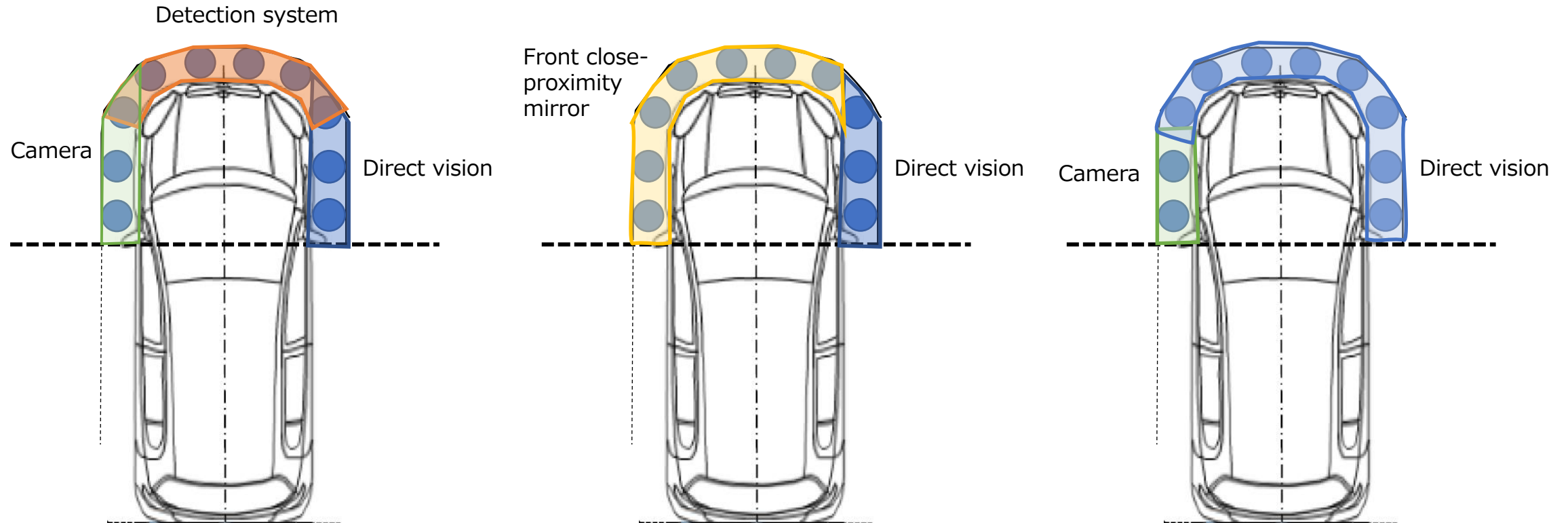

Requirements

On-off conditions of the Close-proximity camera system or detection system

Direct vision or mirrors always provide vision.

On the other hand, electrical system can not always active due to power or other static purposes. Therefore, driver's on-demand activation allowed.

- Close-proximity front and lateral side view camera system and detection system shall be activated easily by the driver's operations when the gear in the out of parking range.
- Close-proximity camera system or detection system that can not cover all field of means for driver awareness at the same time shall be easily show area of the driver's interest by the driver's operations.
- The front and lateral side view image may change the camera view by the driver's operation or automatically without the driver's operations.

Requirements

Exemption by blind area caused by A-pillar and side-mirror mount

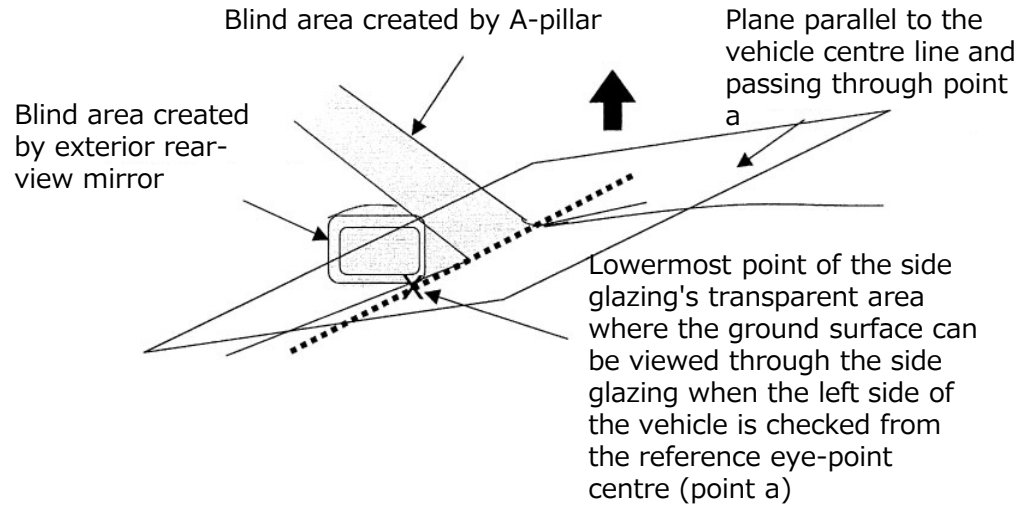

The range of the blind area created by the A-pillar or exterior rear-view mirror in paragraph 15.2.4.10. shall be an area that meets the following formula. In this case, if there are more than one blind area, each blind area shall meet the conditions of the formulae.

$$X \leq 0.292 \cdot L - 0.203$$

Where:

X [m]: is the limit of the excluded area, i.e. the distance between the centre of a cylinder in contact with the front edge of the blind area and the centre of a cylinder in contact with its rear edge.

L [m]: is located inside the blind area created by the A-pillar or exterior rear-view mirror. Distance between the rear edge of a cylinder in contact with the rear edge of the blind area and the front edge of the rear wheel.

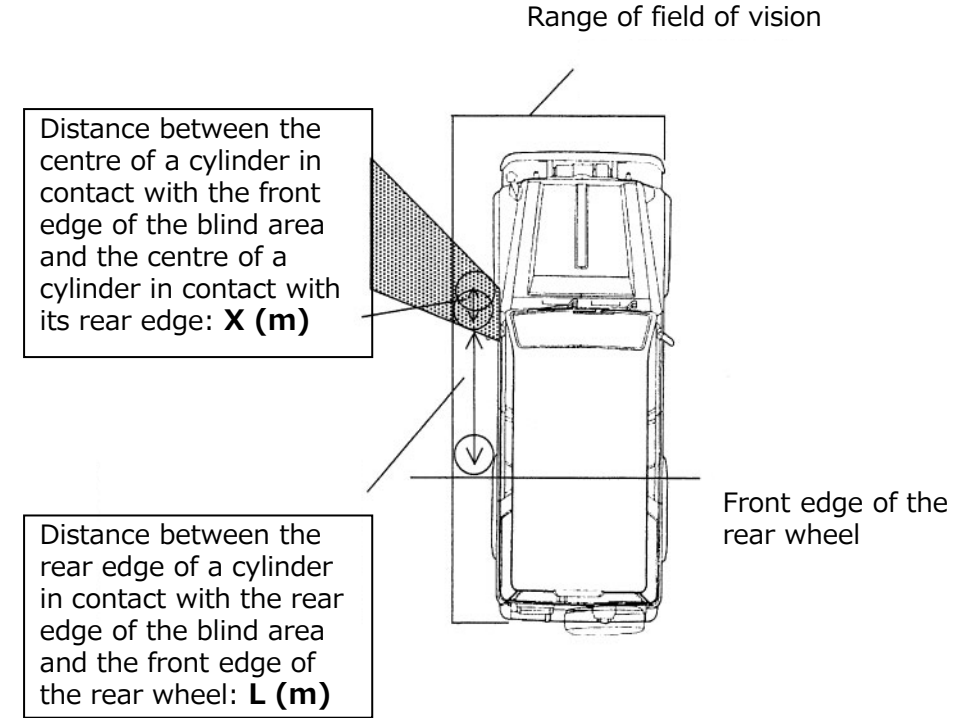

Range of exemption was defined based on the study about blind area that driver can stop vehicle after awareness of VRU before contact. (See Appendix).

***Right-handed drive case**

Structure of the regulation

Common structure with reversing regulation (R-158).

- ✓ Part I only for mirror
 - ✓ Static test of mirrors covered by other regulations.
- ✓ Part II Installation
 - ✓ Technology neutral approach applied.
 - ✓ Add new requirements for each means.
 - ✓ Field of driver's close-proximity awareness.
 - ✓ Direct vision from adjusted driver's ocular point.
 - ✓ Requirements for camera and detection system.
 - ✓ Test method for detection.
 - ✓ Field of driver's front close-proximity awareness to be satisfied by the combination of means for driver's front close-proximity awareness.

Status

Discussion almost finished in the IWG.

We plan to propose this regulation to the next GRSG in April.
Additional discussion and line-by-line review for finalizing proposal to be held at the next VRU-Proxi IWG #21 on 24-26, November.
If you have interest for the discussion, please attend next VRU-IWG.

Please review our draft and give feedback to us before the IWG.
Depends on the feedback, we will have e-mail or taskforce discussion in advance if needed.

Contact: JAPAN Akinari Hirao, Ph. D. (akinari.hirao@aist.go.jp)

Appendix

Study about passenger's side blind spot exemption (1)

Concept

Normal vehicle has blind spot for passenger's side by A-pillar and side mirror mount.
If no blind spot allowed, basically all vehicle need to have mirror or camera.
Therefore, Japan studied non-critical condition for accident before domestic application.

Accident case is run over by rear wheel in this blind spot.
To determine the condition of vehicle speed and VRU location in order to vehicle can stop safely.

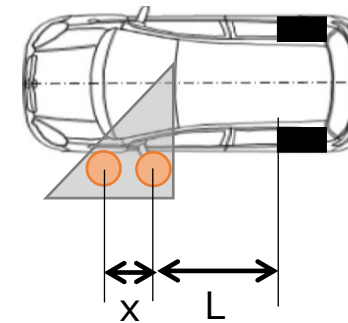
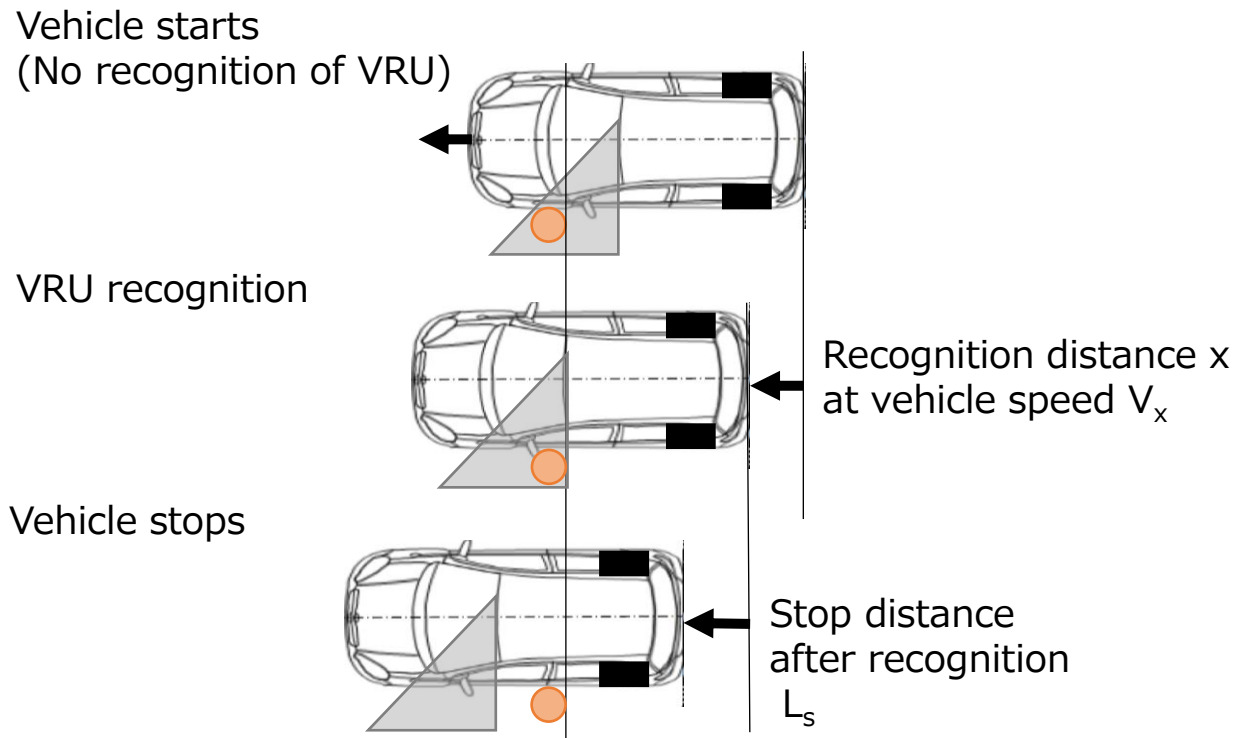

If $L_s \leq L$,
vehicle can stop before run over by rear wheel.

L_s is in proportion to V_x .
Therefore, formula can express as

$$x \leq aL + b$$

Study about passenger's side blind spot exemption (2)

Methods

30 Participants (20s~50s, Male 14, Female 16)

Blind spot by A-Pillar and side mirror mount

Blind spot length X [m]:
 (Distance between objects
 0, 0.2, 0.4, 0.6, 0.8 m)

Vehicle speed when object
 recognition by peripheral vision
 : V [m/s]

Stop distance after recognition
 : L_s [m]

Distance between recognition and
 rear wheel: L [m]

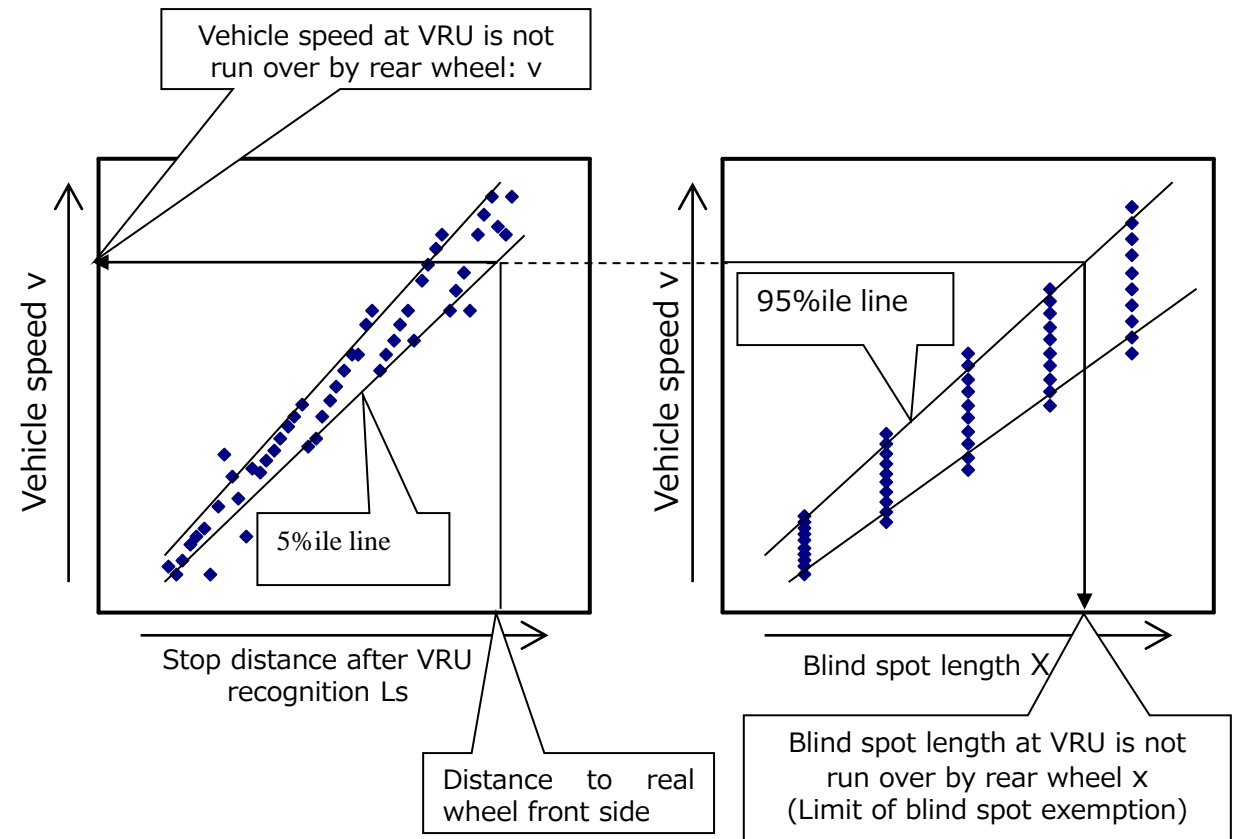
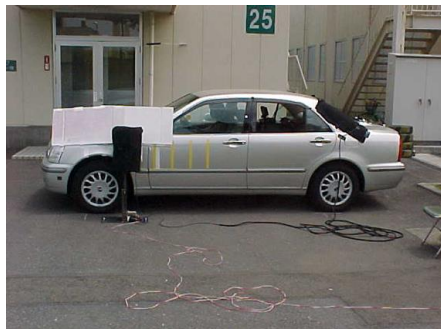
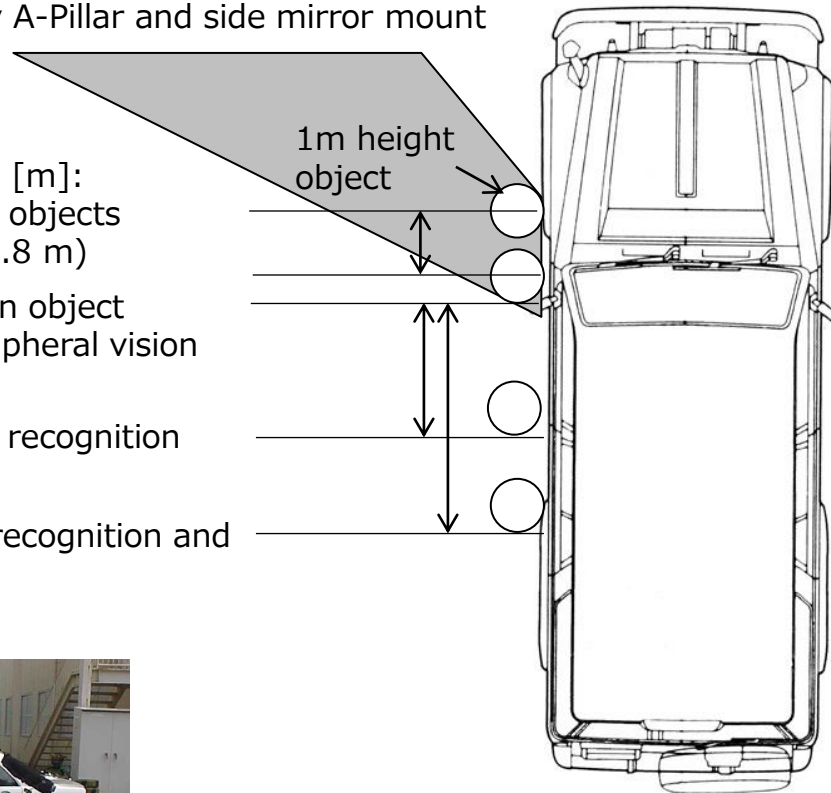

Study about passenger's side blind spot exemption (3)

Results

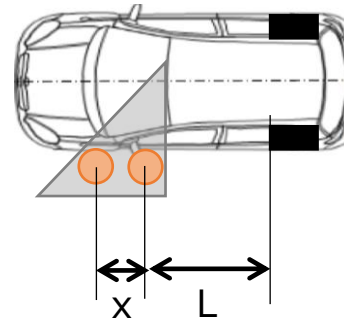
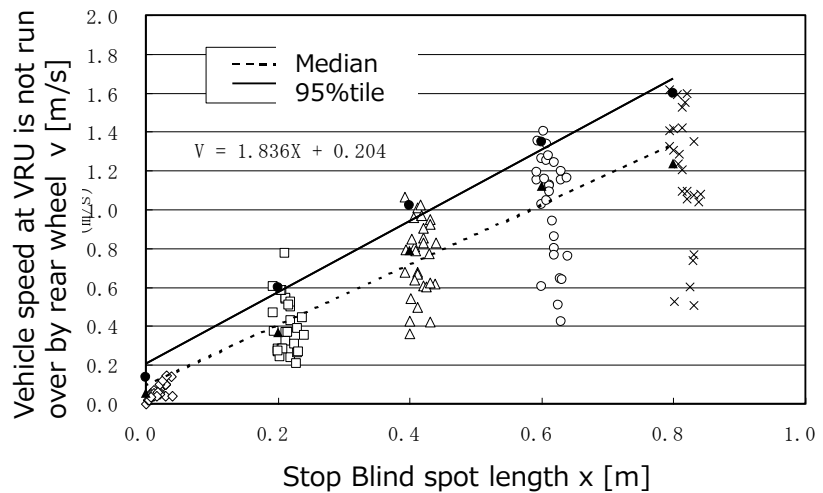
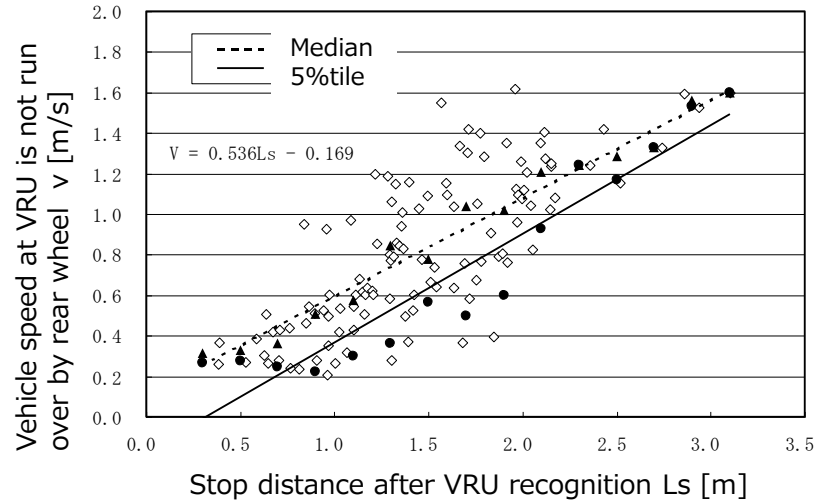

Blind spot exemption
 $x < 0.292L - 0.203$

