

**Economic and Social Council**Distr.: General
20 September 2021

Original: English

Economic Commission for Europe

Inland Transport Committee

World Forum for Harmonization of Vehicle Regulations**Working Party on Passive Safety****Seventieth session**

Geneva, 6–10 December 2021

Item 12 of the provisional agenda

UN Regulation No. 135 (Pole Side Impact (PSI))**Proposal for the 02 series of amendments to UN
Regulation No. 135 (Pole Side Impact (PSI))****Submitted by the expert from the Netherlands ***

The text reproduced below was prepared by the expert from the Netherlands to introduce requirements concerning post-crash electrical safety in the event of a pole side impact collision. It is based on informal document GRSP-69-10 submitted by the expert from the Netherlands and informal document GRSP-69-04 submitted by the expert from the European Association of Automotive Suppliers (CLEPA) at the sixty-ninth session of the Working Party on Passive Safety (GRSP). The modifications to the current text of the UN Regulation are marked in bold for new or strikethrough for deleted characters.

* In accordance with the programme of work of the Inland Transport Committee for 2021 as outlined in proposed programme budget for 2021 (A/75/6 (Sect.20), para 20.51), the World Forum will develop, harmonize and update UN Regulations in order to enhance the performance of vehicles. The present document is submitted in conformity with that mandate.



I. Proposal

Contents, amend to read:

"Contents

Page

Regulation

1. Scope
2. Definitions.....	...
3. Application for approval
4. Approval
5. Requirements.....	...
6. Modification of the vehicle type and extension of approval
7. Conformity of production.....	...
8. Penalties for non-conformity of production
9. Production definitively discontinued.....	...
10. Names and addresses of Technical Services responsible for conducting approval tests, and of Type Approval Authorities
11. Transitional Provisions

Annexes

1 Communication.....	...
2 Arrangement of the approval mark
3 Dynamic pole side impact test procedure.....	...
4 Seat adjustment and installation requirements for the WorldSID 50th percentile adult male dummy.....	...
5 Description of the three-dimensional H-point machine (3-D H machine)
6 Test conditions and procedures for the assessment of post-crash hydrogen fuel system integrity
7 Impact reference line.....	...
8 Impact angle.....	...
9 Pitch and roll angle references
10 Determination of WorldSID 50th percentile adult male performance criteria
11 Test procedures for the protection of the occupants of vehicles operating on electrical power from high voltage and electrolyte spillage.....	..."

Text of the UN Regulation,

Paragraph 2.14., amend to read:

"2.14. *"Passenger compartment with regard to occupant protection"* means the space for occupant accommodation, bounded by the roof, floor, side walls, doors, outside glazing and front bulkhead and the plane of the rear compartment bulkhead or the plane of the rear-seat back support."

Insert new paragraph 2.15., to read:

"2.15. *"Passenger compartment for electric safety assessment"* means the space for occupant accommodation, bounded by the roof, floor, side walls, doors, outside glazing, front bulkhead and rear bulkhead, or rear gate, as

well as by the electrical protection barriers and enclosures provided for protecting the occupants from direct contact with high voltage live parts."

Paragraphs 2.15. to 2.25.(former), renumber as paragraph 2.16. to 2.26.

Paragraph 2.26. (former), renumber as paragraph 2.27. and amend to read:

- "2.27. **"Vehicle type"** means a category of vehicles, the design characteristics of which do not differ in such essential respects as:
- (a) The type of protective system(s);
 - (b) The type of front seat(s);
 - (c) The vehicle width;
 - (d) The wheelbase and overall length of the vehicle;
 - (e) The structure, dimensions, lines and materials of the side walls of the passenger compartment, including any optional arrangements or interior fittings within or about the side walls of the passenger compartment;
 - (f) The type of door latches and hinges;
 - (g) The type of fuel system(s);
 - (h) The unladen vehicle mass and the rated cargo and luggage mass;
 - (i) The sitting of the engine (front, rear or centre);
 - (j) **The locations of the REESS; in so far as they have a negative effect on the result of the impact test prescribed in this Regulation."**

Paragraph 2.27.(former), renumber as paragraph 2.28.

Insert new paragraphs 2.29. to 2.56., to read:

- "2.29. **"High voltage"** means the classification of an electric component or circuit, if its working voltage is > 60 V and $\leq 1,500$ V direct current (DC) or > 30 V and $\leq 1,000$ V alternating current (AC) root-mean-square (rms).
- 2.30. **"Rechargeable Electrical Energy Storage System (REESS)"** means the rechargeable energy storage system that provides electric energy for electrical propulsion.
- A battery whose primary use is to supply power for starting the engine and/or lighting and/or other vehicle auxiliaries' systems is not considered as a REESS.
- The REESS may include the necessary systems for physical support, thermal management, electronic controls and casing.
- 2.31. **"Electrical protection barrier"** means the part providing protection against direct contact to the high-voltage live parts.
- 2.32. **"Electric power train"** means the electrical circuit which includes the traction motor(s), and may also include the REESS, the electrical energy conversion system, the electronic converters, the associated wiring harness and connectors, and the coupling system for charging the REESS.
- 2.33. **"Live parts"** means conductive part(s) intended to be electrically energized under normal operating conditions.
- 2.34. **"Exposed conductive part"** means the conductive part which can be touched under the provisions of the protection degree IPXXB and which is not normally energized, but which can become electrically energized under isolation failure conditions. This includes parts under a cover that can be removed without using tools.
- 2.35. **"Direct contact"** means the contact of persons with high voltage live parts.

- 2.36. **"Indirect contact"** means the contact of persons with exposed conductive parts.
- 2.37. **"Protection degree IPXXB"** means protection from contact with high voltage live parts provided by either an electrical protection barrier or an enclosure and tested using a Jointed Test Finger (IPXXB) as described in paragraph 4. of Annex 11.
- 2.38. **"Working voltage"** means the highest value of an electrical circuit voltage root-mean-square (rms), specified by the manufacturer, which may occur between any conductive parts in open circuit conditions or under normal operating conditions. If the electrical circuit is divided by galvanic isolation, the working voltage is defined for each divided circuit, respectively.
- 2.39. **"Coupling system for charging the Rechargeable Electrical Energy Storage System (REESS)"** means the electrical circuit used for charging the REESS from an external electrical power supply including the vehicle inlet.
- 2.40. **"Electrical chassis"** means a set made of conductive parts electrically linked together, whose electrical potential is taken as reference.
- 2.41. **"Electrical circuit"** means an assembly of connected live parts which is designed to be electrically energized in normal operation.
- 2.42. **"Electrical energy conversion system"** means a system (e.g. fuel cell) that generates and provides electrical energy for electrical propulsion.
- 2.43. **"Electronic converter"** means a device capable of controlling and/or converting electrical power for electrical propulsion.
- 2.44. **"Enclosure"** means the part enclosing the internal units and providing protection against any direct contact.
- 2.45. **"High voltage bus"** means the electrical circuit, including the coupling system for charging the REESS, that operates on a high voltage. Where electric circuits, that are galvanically connected to each other and fulfil the specific voltage condition, only the components or parts of the electric circuit that operate on high voltage are classified as a high voltage bus.
- 2.46. **"Solid insulator"** means the insulating coating of wiring harnesses, provided in order to cover and prevent the high voltage live parts from any direct contact.
- 2.47. **"Automatic disconnect"** means a device that when triggered, galvanically separates the electrical energy sources from the rest of the high voltage circuit of the electric power train.
- 2.47. **"Open type traction battery"** means a type of battery requiring filling with liquid and generating hydrogen gas that is released to the atmosphere.
- 2.49. **"Aqueous electrolyte"** means an electrolyte based on water solvent for the compounds (e.g. acids, bases) providing conducting ions after its dissociation.
- 2.50. **"Electrolyte leakage"** means the escape of electrolyte from the REESS in the form of liquid.
- 2.51. **"Non-aqueous electrolyte"** means an electrolyte not based on water as the solvent.
- 2.52. **"Normal operating conditions"** include operating modes and conditions that can reasonably be encountered during typical operation of the vehicle including driving at legally posted speeds, parking and standing in traffic, as well as, charging using chargers that are compatible with the specific charging ports installed on the vehicle. It does not include, conditions where the vehicle is damaged, either by a crash, road debris or

vandalization, subjected to fire or water submersion, or in a state where service and or maintenance is needed or being performed.

- 2.53. **"Specific voltage condition"** means the condition that the maximum voltage of a galvanically connected electric circuit between a DC live part and any other live part (DC or AC) is ≤ 30 V AC (rms) and ≤ 60 V DC.

Notes:

When a DC live part of such an electric circuit is connected to electrical chassis and the specific voltage condition applies, the maximum voltage between any live part and the electrical chassis is ≤ 30 V AC (rms) and ≤ 60 V DC.

For pulsating DC voltages (alternating voltages without change of polarity) the DC threshold shall be applied.

- 2.54. **"State of Charge (SOC)"** means the available electrical charge in a REESS expressed as a percentage of its rated capacity.
- 2.55. **"Fire"** means the emission of flames from the vehicle. Sparks and arcing shall not be considered as flames.
- 2.56. **"Explosion"** means the sudden release of energy sufficient to cause pressure waves and/or projectiles that may cause structural and/or physical damage to the surrounding of the vehicle."

Insert new paragraph 3.2.6., to read:

- "3.2.6. A general description of the electrical power source type, location and the electric power train (e.g. hybrid, electric)."

Paragraphs 4.3. and 4.4., amend to read:

- "4.3. An approval number shall be assigned to each type approved in accordance with Schedule 4 of the Agreement (E/ECE/TRANS/505/Rev.3 and Amend.1).
- 4.4. Notice of approval or of refusal of approval of a vehicle type pursuant to this Regulation shall be communicated by the Parties to the Agreement which apply this Regulation by means of a form conforming to the model in Annex 1 to this UN Regulation."

Paragraph 4.9., amend to read:

- "4.9. Annex 2 to this Regulation gives examples of the arrangements of approval marks."

Paragraph 5.2., amend to read:

- "5.2. The results of an approval test conducted in accordance with paragraph 5.1. shall be considered satisfactory, if the requirements of paragraphs 5.3., 5.4. and 5.5. are met.

Additionally, vehicles equipped with electric power train shall meet the requirements of paragraph 5.6. This can be met by a separate impact test at the request of the manufacturer and after validation by the Technical Service, provided that the electrical components do not influence the occupant protection performance of the vehicle type as defined in paragraphs 5.3. to 5.5. of this Regulation. In case of this condition the requirements of paragraph 5.6. shall be checked in accordance with the methods set out in Annex 3 to this Regulation, except paragraphs 8. of Annex 3."

Insert new paragraphs 5.6. to 5.6.4., to read:

- "5.6. Following the test conducted in accordance with the procedure defined in Annex 3 to this Regulation, the electric power train operating on high voltage and the high voltage systems which are galvanically connected to

the high voltage bus of the electric power train shall meet the following requirements:

5.6.1. Protection against electrical shock

After the impact, the high voltage buses shall meet at least one of the four criteria specified in paragraph 5.6.1.1. through paragraph 5.6.1.4.2. below.

If the vehicle has an automatic disconnect function, or device(s) that conductively divide the electric power train circuit during driving condition, at least one of the following criteria shall apply to the disconnected circuit or to each divided circuit individually after the disconnect function is activated.

However, criteria defined in 5.6.1.4. below shall not apply if more than a single potential of a part of the high voltage bus is not protected under the conditions of protection degree IPXXB.

In the case that the crash test is performed under the condition that part(s) of the high voltage system are not energized and with the exception of any coupling system for charging the REESS which is not energized during driving condition, the protection against electrical shock shall be proved by either paragraph 5.6.1.3. or paragraph 5.6.1.4. below for the relevant part(s).

5.6.1.1. Absence of high voltage

The voltages U_b , U_1 and U_2 of the high voltage buses shall be equal or less than 30 VAC or 60 VDC within 60 seconds after the impact when measured in accordance with paragraph 2. of Annex 11.

5.6.1.2. Low electrical energy

The Total Energy (TE) on the high voltage buses shall be less than 0.2 joules when measured according to the test procedure as specified in paragraph 3. of Annex 11 with the formula (a). Alternatively, the total energy (TE) may be calculated by the measured voltage U_b of the high voltage bus and the capacitance of the X-capacitors (C_x) specified by the manufacturer according to formula (b) of paragraph 3. of Annex 11.

The energy stored in the Y-capacitors (TE_{y1} , TE_{y2}) shall also be less than 0.2-joules. This shall be calculated by measuring the voltages U_1 and U_2 of the high voltage buses and the electrical chassis, and the capacitance of the Y-capacitors specified by the manufacturer according to formula (c) of paragraph 3. of Annex 11.

5.6.1.3. Physical protection

For protection against direct contact with high voltage live parts, the protection degree IPXXB shall be provided.

The assessment shall be conducted in accordance with paragraph 4 of Annex 11.

In addition, for protection against electrical shock which could arise from indirect contact, the resistance between all exposed conductive parts of electrical protection barriers/enclosures and the electrical chassis shall be lower than 0.1 Ω and the resistance between any two simultaneously reachable exposed conductive parts of electrical protection barriers/enclosures that are less than 2.5 m from each other shall be less than 0.2 Ω when there is current flow of at least 0.2 A. This resistance may be calculated using the separately measured resistances of the relevant parts of electric path.

These requirements are satisfied if the galvanic connection has been made by welding. In case of doubt or the connection is established by mean other

than welding, measurements shall be made by using one of the test procedures described in paragraph 4.1. of Annex 11.

5.6.1.4. Isolation resistance

The criteria specified in paragraphs 5.6.1.4.1. and 5.6.1.4.2. below shall be met.

The measurement shall be conducted in accordance with paragraph 5. of Annex 11.

5.6.1.4.1. Electric power train consisting of separate DC- or AC-buses

If the AC high voltage buses and the DC high voltage buses are galvanically isolated from each other, isolation resistance between the high voltage bus and the electrical chassis (R_i , as defined in paragraph 5. of Annex 11) shall have a minimum value of 100 Ω/V of the working voltage for DC buses, and a minimum value of 500 Ω/V of the working voltage for AC buses.

5.6.1.4.2. Electric power train consisting of combined DC- and AC-buses

If the AC high voltage buses and the DC high voltage buses are conductively connected, they shall meet one of the following requirements:

- (a) Isolation resistance between the high voltage bus and the electrical chassis shall have a minimum value of 500 Ω/V of the working voltage;
- (b) Isolation resistance between the high voltage bus and the electrical chassis shall have a minimum value of 100 Ω/V of the working voltage and the AC bus meets the physical protection as described in paragraph 5.6.1.3;
- (c) Isolation resistance between the high voltage bus and the electrical chassis shall have a minimum value of 100 Ω/V of the working voltage and the AC bus meets the absence of high voltage as described in paragraph 5.6.1.1.

5.6.2. Electrolyte spillage

5.6.2.1. In case of aqueous electrolyte REESS.

For a period from the impact until 60 minutes after the impact, there shall be no electrolyte leakage from the REESS into the passenger compartment and no more than 7 per cent by volume of the REESS electrolyte with a maximum of 5.0 l leaked from the REESS to the outside of the passenger compartment. The leaked amount of electrolyte can be measured by usual techniques of determination of liquid volumes after its collection. For containers containing Stoddard, coloured coolant and electrolyte, the fluids shall be allowed to separate by specific gravity then measured.

5.6.2.2. In case of non-aqueous electrolyte REESS.

For a period from the impact until 60 minutes after the impact, there shall be no liquid electrolyte leakage from the REESS into the passenger compartment, luggage compartment and no liquid electrolyte leakage to outside the vehicle. This requirement shall be verified by visual inspection without disassembling any part of the vehicle.

5.6.3. REESS retention

REESS shall remain attached to the vehicle by at least one component anchorage, bracket, or any structure that transfers loads from REESS to the vehicle structure, and REESS located outside the passenger compartment shall not enter the passenger compartment.

5.6.4. REESS fire hazards

For a period from the impact until 60 minutes after the impact, there shall be no evidence of fire or explosion from the REESS."

Paragraphs 6.1. to 6.2., amend to read:

- "6.1. Every modification of the vehicle type with regard to this Regulation shall be notified to the Type Approval Authority which approved that vehicle type. The Type Approval Authority may then either:
- (a) Decide, in consultation with the manufacturer, that a new type approval is to be granted; or
 - (b) Apply the procedure contained in paragraph 6.1.1. (Revision) and, if applicable, the procedure contained in paragraph 6.1.2. (Extension).
- 6.1.1. **Revision**
- When the details recorded in the information documents have changed and the Type Approval Authority considers that the modifications made are unlikely to have appreciable adverse effect, and that in any case the vehicle still meets the requirements, the modification shall be designated a "revision".
- In such a case, the Type Approval Authority shall issue the revised pages of the information documents as necessary, marking each revised page to show clearly the nature of the modification and the date of re-issue. A consolidated, updated version of the information documents accompanied by a detailed description of the modification, shall be deemed to meet this requirement.
- 6.1.2. **Extension**
- The modification shall be designated an "extension" if, in addition to the change of the particulars recorded in the information folder:
- (a) Further inspections or tests are required; or
 - (b) Any information on the communication document (with the exception of its attachments) has changed; or
 - (c) Approval to a later series of amendments is requested after its entry into force.
- 6.2. Notice of confirmation, extension, or refusal of approval shall be communicated by the procedure specified in paragraph 4.3. above, to the Contracting Parties to the Agreement applying this Regulation. In addition, the index to the information documents and to the test reports, attached to the communication document of Annex 1, shall be amended accordingly to show the date of the most recent revision or extension."

Paragraph 6.3 and 6.4., shall be deleted.

Paragraph 7, amend to read:

"7. Conformity of production

The conformity of production procedures shall comply with those set out in the Agreement, Schedule 1 (E/ECE/TRANS/505/Rev.3 and Amend.1), with the following requirements:"

Paragraphs 8.1. and 8.2., amend to read:

- "8.1. The approval granted in respect of a vehicle type pursuant to this Regulation may be withdrawn if the requirement laid down in paragraph 7.1. above is not complied with.
- 8.2. If a Contracting Party to the Agreement applying this UN Regulation

withdraws an approval it has previously granted, it shall forthwith so notify the other Contracting Parties applying this Regulation, by means of a copy of the approval form bearing at the end, in large letters, the signed and dated annotation "APPROVAL WITHDRAWN".

Paragraph 9., amend to read:

"9. Production definitively discontinued

If the holder of the approval completely ceases to manufacture the type of vehicle approved in accordance with the Regulation, he shall so inform the Type Approval Authority which granted the approval. Upon receiving the relevant communication that Type Approval Authority shall inform thereof the other Parties to the Agreement applying this Regulation by means of a copy of the approval form bearing at the end, in large letters, the signed and dated annotation "PRODUCTION DISCONTINUED".

Insert new paragraphs 11.6. to 11.10., to read:

- "11.6.** As from the official date of entry into force of the 02 series of amendments, no Contracting Party applying this Regulation shall refuse to grant or refuse to accept type-approvals under this Regulation as amended by the 02 series of amendments.
- 11.7.** As from [1 September 2023], Contracting Parties applying this Regulation shall not be obliged to accept type-approvals of vehicles according to the preceding series of amendments, first issued after [1 September 2023].
- 11.8.** Contracting Parties applying this Regulation shall continue to accept type-approvals of vehicles according to the preceding series of amendments to the Regulation first issued before [1 September 2023], provided the transitional provisions in these respective previous series of amendments foresee this possibility.
- 11.9.** Contracting Parties applying this Regulation may grant type-approvals according to any preceding series of amendments to this Regulation.
- 11.10.** Contracting Parties applying this Regulation shall continue to grant extensions of existing approvals to any preceding series of amendments to this Regulation.
- 11.11.** Notwithstanding the transitional provisions above, Contracting Parties who start to apply this Regulation after the date of entry into force of the most recent series of amendments are not obliged to accept type-approvals which were granted in accordance with any of the preceding series of amendments to this Regulation."

Annex 1, item 5., amend to read:

- "5. Brief description of the vehicle type as regards its structure, dimensions, lines and constituent materials**
....."

Insert new paragraph 5.1. to 8., to read:

- "5.1. Description of the protective system installed in the vehicle**
.....
- 5.2. Description of interior arrangements or fittings that might affect the tests**
.....
- 5.3. Location of the electrical power source**

- 6. **Site of engine: forward/rear/central²**
- 7. **Drive: front-wheel/rear-wheel²**
- 8. **Mass of vehicle submitted for testing:**
Front axle:
Rear axle:
Total:"

Items 6. to 17.(former), renumber as paragraph 9. to 20.

Annex 2, amend to read:

“Annex 2

Arrangement of the approval mark

Model A
 (See paragraph 4.5. of this Regulation)

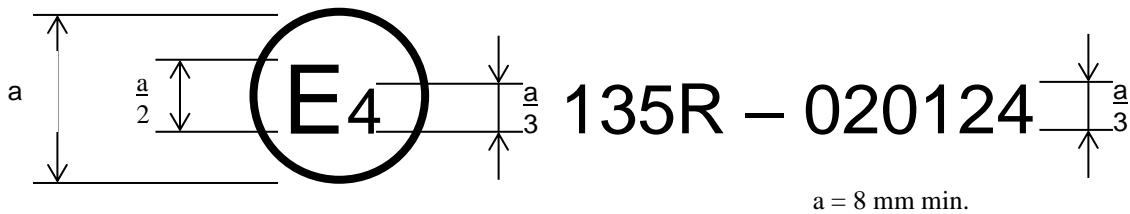

The above approval mark affixed to a vehicle shows that the vehicle type concerned has, with regard to its pole side impact performance, been approved in the Netherlands (E 4) pursuant to Regulation No. 135 under approval number **0124**. The approval number indicates that the approval was granted in accordance with the requirements of Regulation No. 135 as amended by the **02** series of amendments.

Model B
 (See paragraph 4.6. of this Regulation)

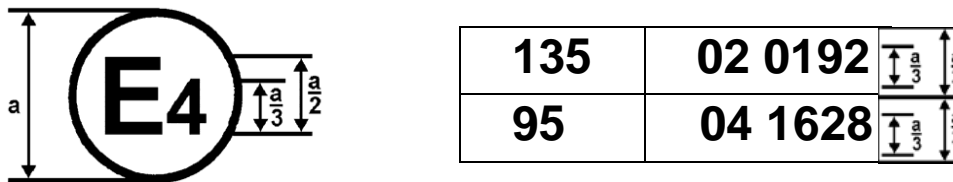

a = 8 mm min.

The above approval mark affixed to a vehicle shows that the vehicle type concerned has been approved in the Netherlands (E 4) pursuant to Regulations Nos. 135 and 95.¹ The first two digits of the approval numbers indicate that, at the dates when the respective approvals were granted, Regulation No. 135 incorporated the **02** series of amendments and Regulation No. 95 incorporated the **04** series of amendments.”

¹ The latter number is given only as an example.

Annex 3, insert new paragraphs 7. to 7.2.2., to read:

- "7. Electrical power train adjustment**
- 7.1. Procedures for SOC adjustment.**
- 7.1.1. The adjustment of SOC shall be conducted at an ambient temperature of 20 ± 10 °C.**
- 7.1.2. The SOC shall be adjusted according to one of the following procedures as applicable. Where different charging procedures are possible, the REESS shall be charged using the procedure which yields the highest SOC:**
- (a) For a vehicle with a REESS designed to be externally charged, the REESS shall be charged to the highest SOC in accordance with the procedure specified by the manufacturer for normal operation until the charging process is normally terminated.**
 - (b) For a vehicle with a REESS designed to be charged only by an energy source on the vehicle, the REESS shall be charged to the highest SOC which is achievable with normal operation of the vehicle. The manufacturer shall advise on the vehicle operation mode to achieve this SOC.**
- 7.1.3. When the vehicle is tested, the SOC shall be no less than 95 per cent of the SOC according to paragraphs 7.1.1. and 7.1.2. for REESS designed to be externally charged and shall be no less than 90 per cent of SOC according to paragraphs 7.1.1. and 7.1.2. for REESS designed to be charged only by an energy source on the vehicle. The SOC will be confirmed by a method provided by the manufacturer."**
- 7.2. The electrical power train shall be energized with or without the operation of the original electrical energy sources (e.g. engine-generator, REESS or electric energy conversion system), however:**
- 7.2.1. By the agreement between Technical Service and manufacturer it shall be permissible to perform the test with all or parts of the electrical power train not being energized insofar as there is no negative influence on the test result. For parts of the electrical power train not energized, the protection against electrical shock shall be proved by either physical protection or isolation resistance and appropriate additional evidence.**
- 7.2.2. In the case where an automatic disconnect is provided, at the request of the manufacturer it shall be permissible to perform the test with the automatic disconnect being triggered. In this case it shall be demonstrated that the automatic disconnect would have operated during the impact test. This includes the automatic activation signal as well as the galvanic separation considering the conditions as seen during the impact."**

Paragraphs 7. to 7.3. (former), renumber as paragraphs 8. to 8.3.

Paragraph 7.4. (former), renumber as paragraph 8.4. and amend to read:

"8.4. A stabilised ... in paragraph 8.3. above prior to the test."

Paragraph 7.5. (former), renumber as paragraphs 8.5.

Paragraph 8 (former), renumber as paragraph 9.

Paragraph 8.1.(former), renumber as paragraph 9.1. and amend to read:

"9.1. A test vehicle prepared in accordance with paragraph 5., paragraph 6., paragraph 7 and paragraph 8. of this annex, shall be impacted into a stationary pole."

Paragraph 8.2. (former), renumber as paragraph 9.2.

Paragraph 8.3. (former), renumber as paragraph 9.3. and amend to read:

"9.3. The angle in paragraph 9.2. above shall be measured between the vehicle longitudinal centreline and a vertical plane parallel to the vehicle impact velocity vector, as indicated in Annex 8, Figure 8-1 (or Figure 8-2) for left (or right) side impact."

Paragraphs 8.4. to 8.6. (former), renumber as paragraphs 9.4. to 9.6.

Insert new Annex 11, to read:

"Annex 11

Test procedures for the protection of the occupants of vehicles operating on electrical power from high voltage and electrolyte spillage

This annex describes test procedures to demonstrate compliance to the electrical safety requirements of paragraph 5.6. of this Regulation.

1. Test setup and equipment

If a high voltage disconnect function is used, measurements are to be taken from both sides of the device performing the disconnect function.

However, if the high voltage disconnect is integral to the REESS or the energy conversion system and the high-voltage bus of the REESS or the energy conversion system is protected according to protection IPXXB following the impact test, measurements may only be taken between the device performing the disconnect function and the electrical loads.

The voltmeter used in this test shall measure DC values and have an internal resistance of at least 10 M Ω .

2. The following instructions may be used if voltage is measured.

After the impact test, determine the high voltage bus voltages (U_b , U_1 , U_2) (see Figure 1 below).

The voltage measurement shall be made not earlier than 10 seconds, but, not later than 60 seconds after the impact.

This procedure is not applicable if the test is performed under the condition where the electric power train is not energized.

Figure 1
Measurement of U_b , U_1 , U_2

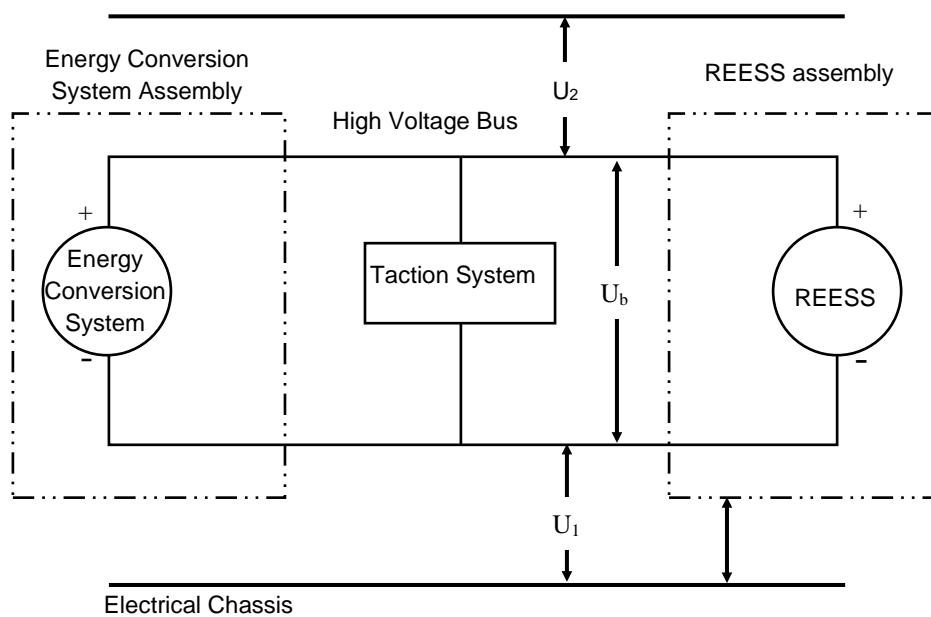

3. Assessment procedure for low electrical energy

Prior to the impact a switch S_1 and a known discharge resistor R_e is connected in parallel to the relevant capacitance (ref. Figure 2 below).

- (a) Not earlier than 10 seconds and not later than 60 seconds after the impact the switch S_1 shall be closed while the voltage U_b and the current I_e are measured and recorded. The product of the voltage U_b and the current I_e shall be integrated over the period of time, starting from the moment when the switch S_1 is closed (t_c) until the voltage U_b falls below the high voltage threshold of 60 V DC (t_h). The resulting integration equals the Total Energy (TE) in joules.

$$TE = \int_{t_c}^{t_h} U_b \times I_e dt$$

- (b) When U_b is measured at a point in time between 10 seconds and 60 seconds after the impact and the capacitance of the X-capacitors (C_x) is specified by the manufacturer, Total Energy (TE) shall be calculated according to the following formula:

$$TE = 0.5 \times C_x \times U_b^2$$

- (c) When U_1 and U_2 (see Figure 1 above) are measured at a point in time between 10 seconds and 60 seconds after the impact and the capacitances of the Y-capacitors (C_{y1} , C_{y2}) are specified by the manufacturer, Total Energy (TE_{y1} , TE_{y2}) shall be calculated according to the following formulas:

$$TE_{y1} = 0.5 \times C_{y1} \times U_1^2$$

$$TE_{y2} = 0.5 \times C_{y2} \times U_2^2$$

This procedure is not applicable if the test is performed under the condition where the electric power train is not energized.

Figure 2
E.g. measurement of high voltage bus energy stored in X-capacitors

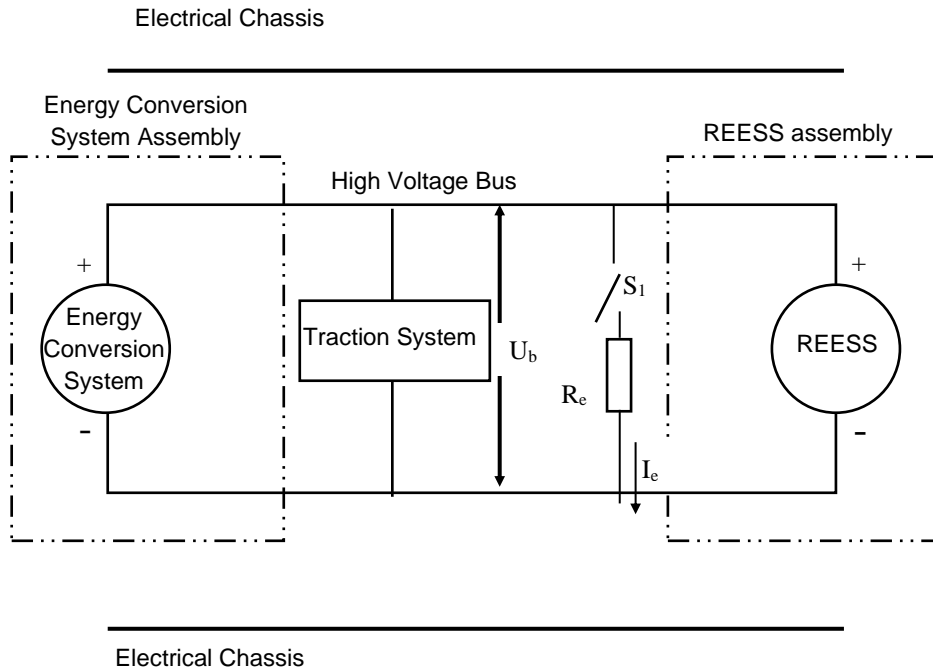

4. Physical protection

Following the vehicle impact test any parts surrounding the high voltage components shall be, without the use of tools, opened, disassembled or removed. All remaining surrounding parts shall be considered part of the physical protection.

The jointed test finger described in Figure 3 shall be inserted into any gaps or openings of the physical protection with a test force of $10\text{ N} \pm 10\text{ per cent}$ for electrical safety assessment. If partial or full penetration into the physical protection by the jointed test finger occurs, the jointed test finger shall be placed in every position as specified below.

Starting from the straight position, both joints of the test finger shall be rotated progressively through an angle of up to 90° with respect to the axis of the adjoining section of the finger and shall be placed in every possible position.

Internal electrical protection barriers are considered part of the enclosure

If appropriate a low-voltage supply (of not less than 40 V and not more than 50 V) in series with a suitable lamp should be connected, between the jointed test finger and high voltage live parts inside the electrical protection barrier or enclosure.

Figure 3
Jointed Test Finger

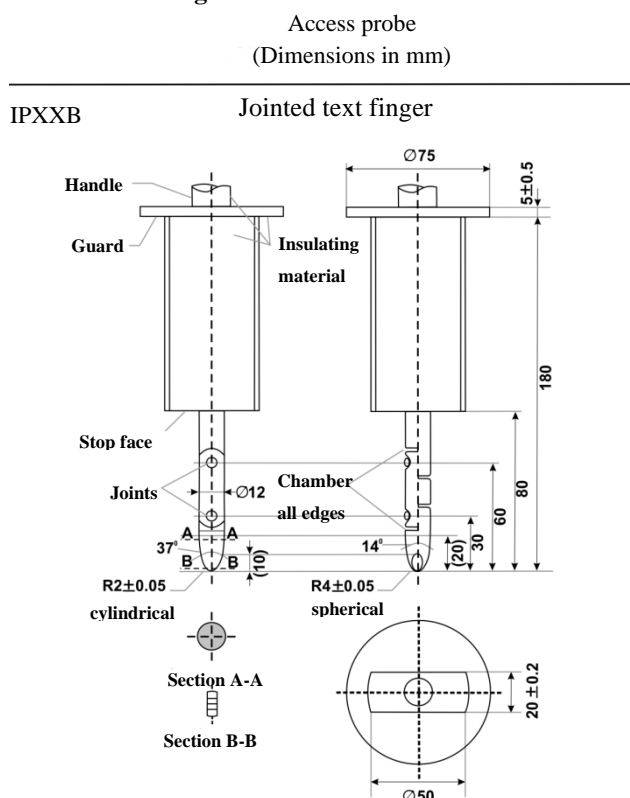

Material: metal, except where otherwise specified

Linear dimensions in mm.

Tolerances on dimensions without specific tolerance:

- (a) on angles: +0/-10 seconds;
- (b) on linear dimensions:
 - (i) up to 25 mm: +0/-0.05;
 - (ii) over 25 mm: ±0.2.

Both joints shall permit movement in the same plane and the same direction through an angle of 90° with a 0 to +10° tolerance.

The requirements of paragraph 5.2.8.1.3. of this Regulation are met if the jointed test finger described in Figure 3, is unable to contact high voltage live parts.

If necessary, a mirror or a fiberscope may be used in order to inspect whether the jointed test finger touches the high voltage buses.

If this requirement is verified by a signal circuit between the jointed test finger and high voltage live parts, the lamp shall not light.

4.1. Test method for measuring electric resistance:

- (a) Test method using a resistance tester.

The resistance tester is connected to the measuring points (typically, electrical chassis and electro conductive enclosure/electrical protection barrier) and the resistance is measured using a resistance tester that meets the specification that follows:

- (i) Resistance tester: Measurement current at least 0.2 A;

- (ii) Resolution: 0.01 Ω or less;
 - (iii) The resistance R shall be less than 0.1 Ω .
- (b) Test method using DC power supply, voltmeter and ammeter.

The DC power supply, voltmeter and ammeter are connected to the measuring points (Typically, electrical chassis and electro conductive enclosure/electrical protection barrier).

The voltage of the DC power supply is adjusted so that the current flow becomes at least 0.2 A.

The current "I" and the voltage "U" are measured.

The resistance "R" is calculated according to the following formula:

$$R = U / I$$

The resistance R shall be less than 0.1 Ω .

Note: If lead wires are used for voltage and current measurement, each lead wire shall be independently connected to the electrical protection barrier/enclosure/electrical chassis. Terminal can be common for voltage measurement and current measurement.

Example of the test method using DC power supply, voltmeter and ammeter is shown below.

Figure 4
Example of the Test Method using DC Power Supply

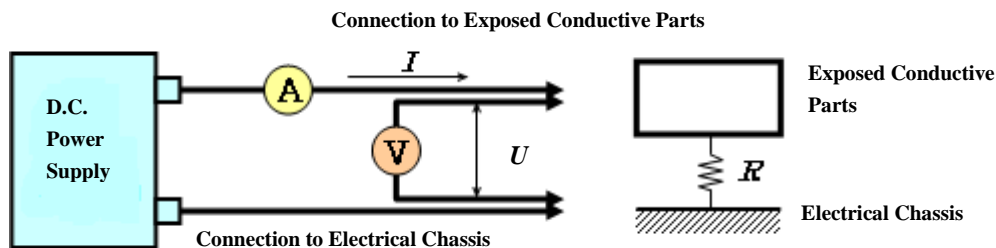

5. Isolation resistance

5.1. General

The isolation resistance for each high voltage bus of the vehicle is measured or shall be determined by calculating the measurement values of each part or component unit of a high voltage bus.

All measurements for calculating voltage(s) and electrical isolation are made after a minimum of 10 seconds after the impact.

5.2. Measurement method

The isolation resistance measurement is conducted by selecting an appropriate measurement method from among those listed in paragraphs 5.2.1. to 5.2.2. of this Annex, depending on the electrical charge of the live parts or the isolation resistance.

The range of the electrical circuit to be measured is clarified in advance, using electrical circuit diagrams. If the high voltage buses are conductively isolated from each other, isolation resistance shall be measured for each electrical circuit.

Moreover, modifications necessary for measuring the isolation resistance may be carried out, such as removal of the cover in order to reach the live parts, drawing of measurement lines and change in software.

In cases where the measured values are not stable due to the operation of the on-board isolation resistance monitoring system, necessary modifications for conducting the measurement may be carried out by stopping the operation of the device concerned or by removing it. Furthermore, when the device is removed, a set of drawings will be used to prove that the isolation resistance between the live parts and the electrical chassis remains unchanged.

These modifications shall not influence the test results.

Utmost care shall be exercised to avoid short circuit and electric shock since this confirmation might require direct operations of the high-voltage circuit.

5.2.1. Measurement method using DC voltage from external sources

5.2.1.1. Measurement instrument

An isolation resistance test instrument capable of applying a DC voltage higher than the working voltage of the high voltage bus shall be used.

5.2.1.2. Measurement method

An isolation resistance test instrument is connected between the live parts and the electrical chassis. The isolation resistance is subsequently measured by applying a DC voltage at least half of the working voltage of the high voltage bus.

If the system has several voltage ranges (e.g. because of boost converter) in conductively connected circuit and some of the components cannot withstand the working voltage of the entire circuit, the isolation resistance between those components and the electrical chassis can be measured separately by applying at least half of their own working voltage with those components disconnected.

5.2.2. Measurement method using the vehicle's own REESS as DC voltage source.

5.2.2.1. Test vehicle conditions

The high voltage-bus is energized by the vehicle's own REESS and/or energy conversion system and the voltage level of the REESS and/or energy conversion system throughout the test shall be at least the nominal operating voltage as specified by the vehicle manufacturer.

5.2.2.2. Measurement instrument

The voltmeter used in this test shall measure DC values and have an internal resistance of at least 10 M Ω .

5.2.2.3. Measurement method

5.2.2.3.1. First step

The voltage is measured as shown in Figure 1 and the high voltage bus voltage (U_b) is recorded. U_b shall be equal to or greater than the nominal operating voltage of the REESS and/or energy conversion system as specified by the vehicle manufacturer.

5.2.2.3.2. Second step

The voltage (U_1) between the negative side of the high voltage bus and the electrical chassis is measured and recorded (see Figure 1).

5.2.2.3.3. Third step

The voltage (U_2) between the positive side of the high voltage bus and the electrical chassis is measured and recorded (see Figure 1).

5.2.2.3.4. Fourth step

If U_1 is greater than or equal to U_2 , a standard known resistance (R_o) is inserted between the negative side of the high voltage bus and the electrical chassis. With R_o installed, the voltage (U_1') between the negative side of the high voltage bus and the electrical chassis is measured (see Figure 5).

The electrical isolation (R_i) is calculated according to the following formula:

$$R_i = R_o * U_b * (1/U_1' - 1/U_1)$$

Figure 5
Measurement of U_1'

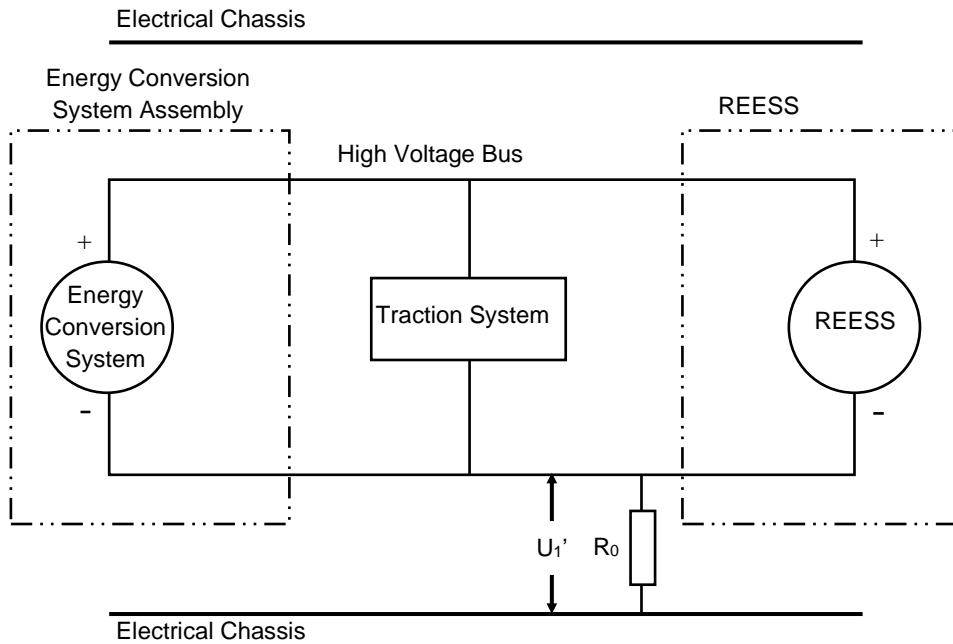

If U_2 is greater than U_1 , insert a standard known resistance (R_o) between the positive side of the high voltage bus and the electrical chassis. With R_o installed, measure the voltage (U_2') between the positive side of the high voltage bus and the electrical chassis (see Figure 6 below). The electrical isolation (R_i) is calculated according to the following formula:

$$R_i = R_o * U_b * (1/U_2' - 1/U_2)$$

Figure 6
Measurement of U_2'

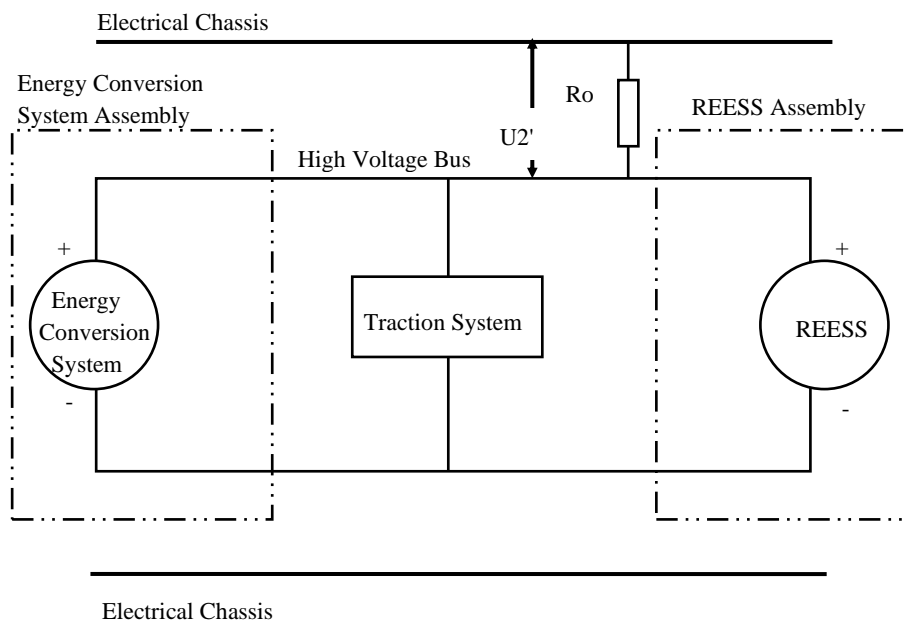

5.2.2.3.5. Fifth step.

The electrical isolation value R_i (in Ω) divided by the working voltage of the high voltage bus (in V) results in the isolation resistance (in Ω/V).

Note: The standard known resistance R_o (in Ω) should be the value of the minimum required isolation resistance (Ω/V) multiplied by the working voltage (V) of the vehicle plus/minus 20 per cent. R_o is not required to be precisely this value since the equations are valid for any R_o ; however, a R_o value in this range should provide a good resolution for the voltage measurements.

6. Electrolyte spillage

An appropriate coating, if necessary, may be applied to the physical protection (casing) in order to confirm if there is any electrolyte leakage from the REESS resulting from the test. Unless the manufacturer provides means to differentiate between the leakage of different liquids, all liquid leakage shall be considered as the electrolyte.

7. REESS retention

Compliance shall be determined by visual inspection."

II. Justification

1. The technical provisions on post-crash electrical safety in global technical regulation (UN GTR) No. 20 are adopted for UN Regulation No. 135.
2. The administrative provisions are adapted to revision 3 of the 1958 Agreement.
3. The technical requirements modified by the 02 series of amendments do not affect the specification of non-Electrified Vehicles. Therefore, there is no need to differentiate the transitional provisions for electrified vehicles and non-electrified vehicles and the standardized provisions given in the general guideline (ECE/TRANS/WP.29/1044/Rev.3) can be used.

4. Paragraph 11.8.: The proposed paragraph 11.8. is, in principle, in accordance with the standardized provision V.8 of the general guideline. However, it is not clear whether "the preceding series" is singular or plural in its English version. With the understanding that it should mean "any of the preceding series", the additional phrase "provided the transitional provisions ..." is supplemented in order to clarify that the possibilities given in such earlier series of amendments are still valid. In the case of UN Regulation No. 135, the following possibilities are foreseen:

(a) UN Regulation No. 135, 01 series of amendments: strengthen the impact speed for vehicles with a vehicle width of 1.50 m or less while no technical change to the other vehicles is required.

(b) Approvals to the original version of UN Regulation No. 135, remain acceptable for vehicles with a vehicle width of more than 1.50 m.
