

## COMMENT ON THE INFORMAL DOCUMENT GRSP-69-26

### Comments on the Informal document GRSP-69-18

The Industry has checked carefully the working document ECE/TRANS/WP.29/GRSP/2021/15 to improve it and point out some open points that have been found and need to be discussed.

Also the Informal document GRSP-69-18 has been taken into account since it was aimed at completing the working document mentioned above.

From our point of view, there are some aspects on the Italian proposal that have to be reconsidered for technical reasons and also there are some other points that have to be even addressed by a more complete and detailed wording of the Regulation.

We will separate this document in two parts:

Part 1: Comments on the document GRSP-69-18 and

Part 2: Comments on the document ECE/TRANS/WP.29/GRSP/2021/15

### Part 1: Comments on the document GRSP-69-18

#### Proposal of Supplement 2 to the 06 series of amendments to UN Regulation No. 22 (Protective helmets)

The integration to the current text of the working document ECE/TRANS/WP.29/GRSP/2021/15 to complete the document and confirm limit value are marked in bold for new or strikethrough for deleted characters.

#### I. Proposal

*New Paragraph 6.3.1.1.*, amend to read:

- 6.3.1.1. If an accessory has any component to be installed on the exterior of the helmet shell within any of the impact areas foreseen in this Regulation and those parts of the accessory have a thickness of more than **3** mm, the accessory shall be tested together with the helmet and the accessory becomes Specific accessory.

**Comment:** This paragraph relates to accessories and, as such, should have to be sent to 6.19

Paragraph 6.3 attains to component or device fitted in the protective helmets ==> thus it appears appropriate

*New Paragraph 6.3.1.2.*, amend to read:

- 6.3.1.2. The helmet shall have some markings on the exterior of the helmet shell or any visible component to take them as a reference for the installation of the Universal accessories main external components.

The area where to fit the universal accessories shall grant at least **30 mm** of distance from any point of any impact affected area to the lower edge of the helmet shell (the lower rubber rim is considered to be helmet shell for this purpose).

*New Paragraph 6.3.1.5., amend to read:*

6.3.1.5. If the helmet is prepared to fit speakers, the helmet shall have a dedicated space ~~in the inner EPS~~ of at least **41** mm diameter and a depth of at least **7** mm and be tested as well according to the tests foreseen in point 7.3. in the X point with the speakers simulators defined in Annex 20. In this case, the helmet will be marked as “S”.

**Comments:** 8 mm EPS pocket depth to be considered

If 45 mm speakers have to be considered, also the pocket dimensions have to be considered in this paragraph.

*New Paragraph 6.19.6.3., amend to read:*

6.19.6.3. The maximum weight of the accessory, including its support if any, shall be no more than **200 g**.

**Comment:** Add the possibility that an accessory could have different components to be attached to different helmet positions. It has already been considered in the original working document text. The paragraph should be amended to read:

6.19.6.3. *The maximum weight of the accessory, or any separately mounted component of the accessory if there are more than one to be fitted in different locations of those foreseen for accessories in this Regulation, including its support if any, shall be no more than [250g]*

It is not clear the wording of the comment: there is no apparent reason to define proper location for the accessories and then to allow positioning for UA out of these areas.  
On the other end it is better to use the wording cumulative weight instead of weight of the accessory including its separated parts.

*New Paragraph 6.19.8.1., amend to read:*

6.19.8.1. The material has to be flexible and of a maximum thickness of **2** mm or

*New Paragraph 7.13.4., amend to read:*

7.13.4. Helmets marked as “UA” must be tested as well with each of the accessory simulators and/or a combination of them, the total weight of the accessories with which the helmet will be tested will not exceed **400g**. The tests done will be specified in the test report. The accessories simulators are defined in Annex 20, Part 3.

*Annex 8 - New figure 1d, amend to read:*

Example of a helmet simulator for accessories projections and surface friction (method B)

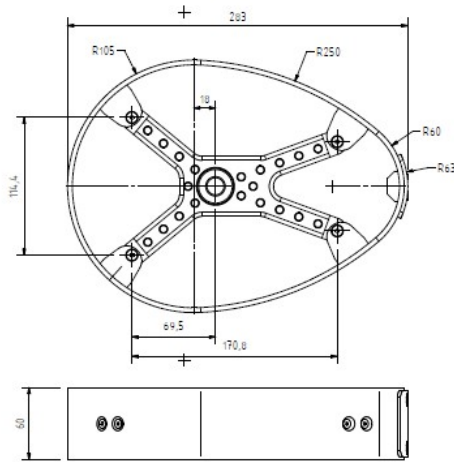

Note: The thickness of the external edge profile is given by the overlapping of two 3 = 3 mm thick polycarbonate sheets. The inside constitutes the frame of the device, the outside can be replaced if damaged.

	Sheet: 1	Note: TESTO	Note: TESTO
		Note: TESTO	Note: TESTO
Description: HELMET SIMULACRUM			
Date: 23/02/2002	Scale: 1 : 2	Weight Kg: N/A	Drawn by: S.C.
Material:		Treatment:	
Drawing nr.:			Rev. 0

**Comment:** This simulator does not reproduce the actual behaviour that the accessory would have if fitted to a helmet. The helmet can rotate around the headform during the test. This simulator only gives one degree of freedom: rotation through the fixation axe

New simulator proposal with three degrees of freedom could better represent what could happen in a real test.

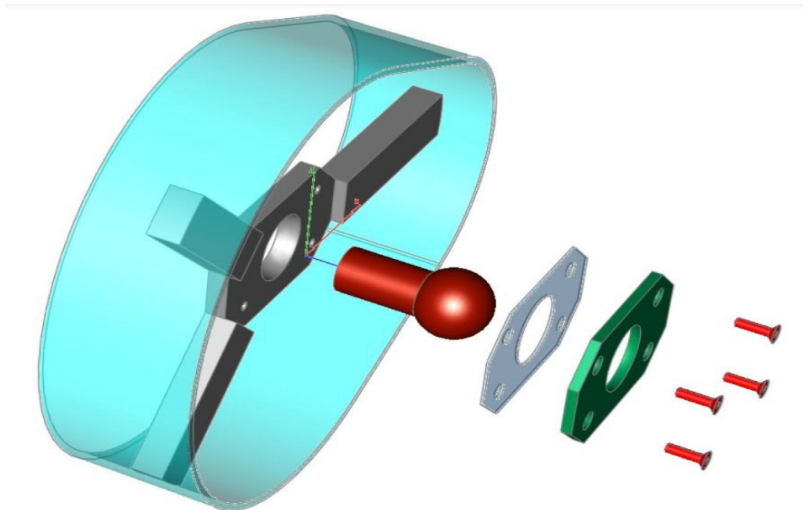

The new proposed system could be calibrated as it is the Hybrid III femur-hip joint.

*New Annex 20, amend to read:*

Test has been designed to be in line with the actual procedures used in the Regulation 22: the test apparatus used to assess the helmet donot foresee any simulation for the neck (such as a similar ball joints). This decision rely historically in the need to have a conservative, repeatable and cost effective test.

The helmet simulator is conservative respect the actual behavior: in the market there are helmet with close fit which has very limited movement as well as other kind where movement around the head may be more. Helmet simulator stays representative of the worst case scenario. The test campaign has demonstrated a direct correlation between pass performance between the test of the accessory when fitted on the helmet and when on the proposed simulator.

## Annex 20

### Accessories assessment and clamping space dimensions for helmets

#### Part 1. Accessories assessment

##### 1. Measurement of the maximum dimensions of externally fitted accessories:

For the measurement of the dimensions, only the accessory plus the support, if any, have to be measured. If the device is fitted with a foldable antenna, the system must fit in the fixture with the antenna in folded position. If the antenna is flexible, the antenna may exceed the fixture dimensions. Flexible, thin components can exceed the volume or can be assembled separately on the shell.

##### 1.1 For front mounted accessories:

Accessories must fit in the following fixtures dimensions:

Figure 1

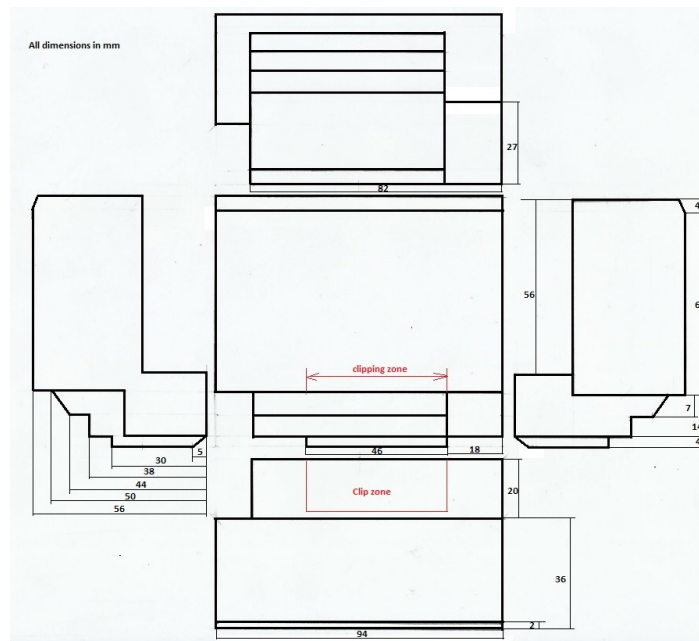

Fixture for left front- side mounting (for right side mounting apply symmetry)

VOLUME: 279,432 mm<sup>3</sup>

**Comment: [Volume was only indicated in the document as a reference for defining the building possibilities, no need to introduce it in the text]**

### 1.2 For side mounting accessories

Figure 2

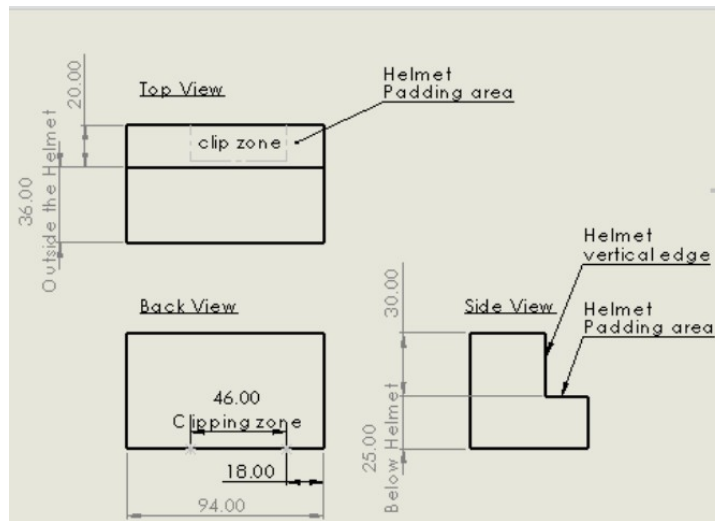

Fixture for left side mounting (for right side mounting apply symmetry)

VOLUME: 233,120 mm<sup>3</sup>

Comment: [Volume was only indicated in the document as a reference for defining the building possibilities, no need to introduce it in the text]

### 1.3 For rear mounting accessories

Figure 3

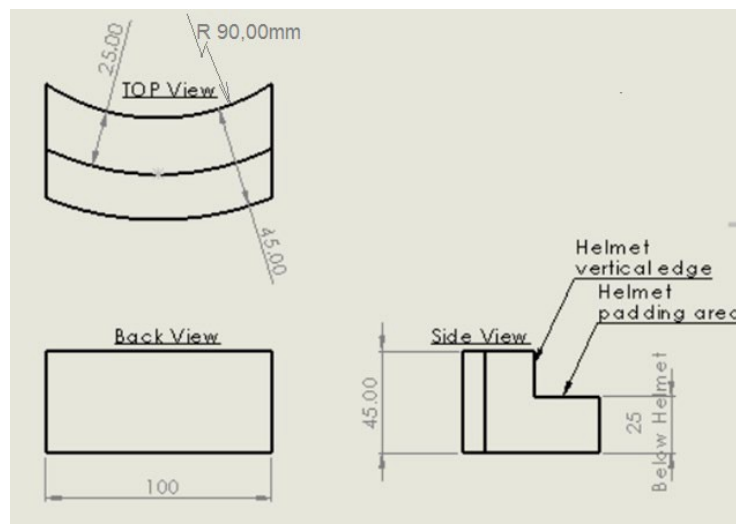

The rear mounting clamping solution offered by the accessories manufacturers will not invade the impact affected area.

VOLUME: 157,957 mm<sup>3</sup>

Comment: [Volume was only indicated in the document as a reference for defining the building possibilities, no need to introduce it in the text]

2. Maximum dimensions of speakers and microphones:

2.1 Speakers

The speakers, measured without comfort cover, must be contained in a cylinder of **40 mm** diameter and height **12 mm**,.

Note: Speakers with diameter up to 45 mm shall be approved, as options, in order to be installed only on helmets specially approved up to this dimension.

Comment: Then either becomes semiuniversal ..... or need special marking non foreseen in the text. Need to study the marking way to avoid misunderstandings or misuse, need to change as well owners manual warnings in both helmets and accessories. Marking paragraphs must be changed accordingly. New marking will be needed.

2.2 Microphone

The microphone must be contained in a parallelepiped of the following dimensions:

Length: 35 mm

Width: 18 mm

Height (dimension from the chin protective padding towards the headform): 11,5 mm

The boom, if any, must be flexible and not have an external diameter of more than **8 mm**

3. Mechanical characterization of the speakers:

- 3.1. **The speaker, with an height more than 8 mm, shall be placed between two parallel plates by means of which a known load can be applied, the surface of the plates shall be large enough to contain a circle of at least 65 mm in diameter. An initial load of 10 N shall be applied, the load shall then be increased at a minimum plates speed of 5 mm/min. until the application of a load of 1000 N (-0+10N).**

Comment: Can be done at 200 mm/min, no changes on the curves are expected and it is much faster for testing purposes. Test until 25KN. Better define a corridor than a single point. Corridor to be determined after intensive testing for evaluating the effects on test results.

The comment appears not to be feasible as the speed mentioned is too high: 200 mm/min would mean 1 mm in 0,3s and thus 8mm in 2,4s with the high probability to damage test equipment when free space is reduced to zero (in less than 1s).

Which is the rationale to choose 25kN? 1kN has been chosen to grant AISI 0 during the compression of the speaker to 8mm which is the height of the simulator.

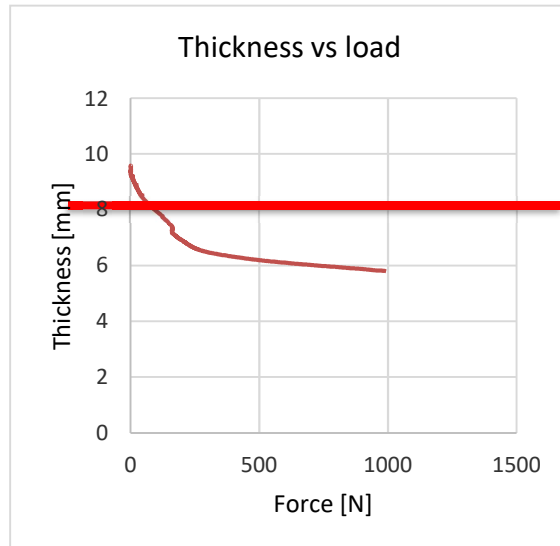

Example of curve

### 3.2 Criteria

**The height of the speaker when subjected to compression with a load of 1000 N (-0+10N) must be less than or equal to 8 mm.**

**Comment:** More tests are necessary. Industry does not have any clear input on the impact this might have on the helmet results. Only one or two helmets reported to be tested and no data from the conditions or geometry of the pockets or EPS or shell or even size tested.

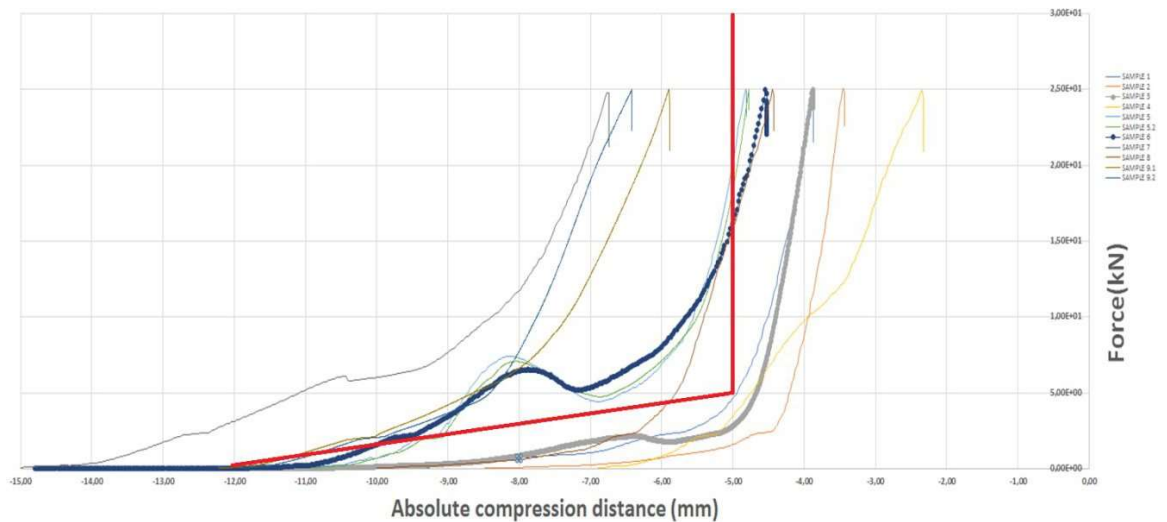

Corridor example

## 4. Speakers and microphone simulators for helmet testing

### 4.1 Speaker simulator

The speaker simulator will be made from rigid plastic and will have a dimension of **40 mm (±0,5 mm)** diameter and **8 mm (±0,5 mm)** thick.

1- There is no explanation or clear rationale to the stated need of 25kN (2500 kgf) to compress the speaker case as for most part of the speaker lower loads are enough to compress the speaker case to 8 mm, which is the height at which the liner of the helmet would start to work. This exact situation is simulated with the proposed speaker simulator 8 mm height.

Apparently, in absence of errors/misunderstandings, from the examination of the graph most of the speaker sold in the market would not satisfy this requirement.

2- BUT PLEASE NOTE: these data appears not in line with the usual experience of any user and with the data obtained by other laboratory.

The helmet manufacturer can allow the possibility of the installation, in a compatible space, also of speakers with a diameter up to 45 mm, in this case the test shall be carried out with a simulator 45 mm ( $\pm 0,5$  mm) diameter and 8 mm ( $\pm 0,5$  mm) thick.

This possibility must be clearly indicated in the instructions to the user

Should be clearly marked on the helmet and on the Accessory mandatory marking. Need to change the marking on the Regulation corresponding paragraph. Need to add in Regulation text, not only in the Annex 20.

Requirements for user instructions must be done in the appropriate paragraph in the Regulation.

#### 4.2. Microphone simulator

The microphone simulator will be made from rigid plastic and will have:

a) a parallelepipedal shape with the following dimensions:

Length: **35 mm ( $\pm 0,5$  mm)** (horizontal transversal dimension)

Width: **18 mm ( $\pm 0,5$  mm)** (vertical dimension)

Height: **11,5 mm ( $\pm 0,5$  mm)** (horizontal longitudinal dimension)

### Part 2. Clamping space dimensions for helmets (OPTIONAL)

1. The helmet clamping free space dimensions for front and side mounting will be, at least, the following ones
- 2.

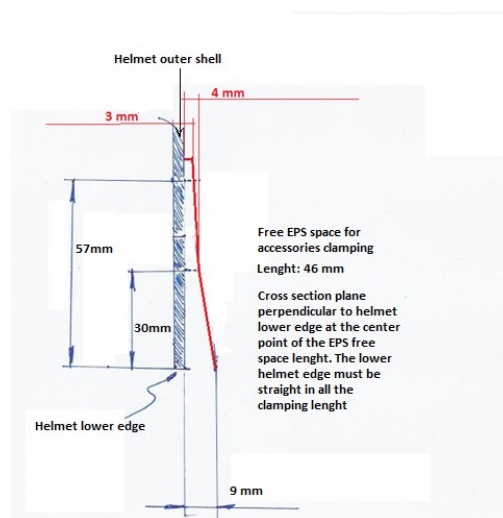

Length of clamping according to the fixture drawings

3. Helmet clamping free space dimensions for rear mounting

The helmet must allow the insertion of a flat metal sheet of 1 mm thickness, as one of the possible fixation systems for rear positioning of the accessories, between the EPS and the external shell.

### Part 3. Accessories simulators for the tests foreseen in 7.13



The shape will be like the correspondent fixture depending on the helmet positioning and will have the following mass:

1. Front mounted accessories: **200 g (-0+10) g**
2. Side mounted accessories: **200 g (-0+10) g**
3. Rear mounted accessories: **200 g (-0+10) g**

**Comment: Freedom to manufacture the simulators?**

Clamping/fixing of the simulator to the helmet can be done at the Technical Service discretion but method must be noted and filed within the test report. The clamping/fixing system together with the fixture must not exceed the target weight.

Note: Only for testing purposes the fixation of the simulator to the helmet with screws is acceptable

## II. Justification

The proposed text integrates and completes document ECE/TRANS/WP.29/GRSP/2021/15, this integration is necessary to specify limit values and procedures left to define at the time of presentation of the working document.

This document had been prepared taking into account indications and information provided by the manufacturers of helmets and accessories and it is based on the outcomes of the tests completed on the most representative available communication accessories and the Helmets ready to be ECE 22.06 approved.

The test procedures and limit values proposed are based on a set of preliminary test activities established to investigate the performance of the products with the final aim to assess their compatibility and the validation of tests equipment and test procedures.

The tests had been completed in compliance with the test procedures stated in the ECE / ONU Regulation 22.06, evaluating the different possible configurations between helmets and accessories.

As base to define the limit to the rigidity of the speaker and the height of the test simulacrum the CEN technical report CEN/TR 16148:2011 (Head and neck impact, burn and noise injury criteria. A Guide for CEN helmet standards committees) has been considered.

**Comment: The criteria used for defining the mechanical prescriptions for aftermarket speakers is different than the one used for evaluating the helmet. If we apply this criteria AIS0 for speakers it should be applied as well for all other hard points that appear during different impacts in several areas which I think it is not the intention for this Supplement. For the head injury criteria we just only take into account PLA and HIC in this Regulation. We should stick to this injury criteria rather than bring a new one for only one component of the helmet.**

The comment leaves to intend that the RATIONALE has been

misunderstood. RATIONALE: the speaker is simulated with a disk 8 mm

height.

When the speaker is higher than 8 mm it is required that the action to compress it to 8 mm will not cause damage to the user. This means that when compressed by 1KN height should be less than 8 mm

1KN has been chosen as AIS 0 is granted till 50g, the mass assumption of helmet +head is 6,2 kg, the test is quasistatic, therefore it is assumed a dynamic multiplier to 3 ==> it is required to get to 8 mm with  $50/3=16g$  which means as

## **Part 2: Comments on the document ECE/TRANS/WP.29/GRSP/2021/15**

Apart from the above comments that have to be discussed in depth, we found additional open points that have to be addressed by the Regulation or we risk to have a text that will not solve all the critical points that will appear when we speak about compatibility of helmets and accessories.

We need to add the following prescriptions:

1. Define a shape and minimum dimensions for bonding surface on the external shell of the helmets.

As the first presented text was considering only clamping and bonding appeared as optional required by Italy, we introduced this possibility but without stating any provisions for the bonding place. This has to be done to prevent bad or insufficient bonding which may lead to losing the device at some point. If there is no provision, no requirement can be asked by TS and everything can be approved.

2. Fixture definition.

Industry has determined that the fixtures proposed had to be modified to avoid some problems of compatibility especially in the full face helmets case.

3. Special prescriptions for EPS pockets when they are limited to the minimum required diameter.

Some provisions for speakers wiring have to be defined, otherwise it risk not to be mounted or that wires/soldering can break while assembling.

4. Dimensional compatibility requirements for fitting speakers in full face helmets.

Requirements for EPS pocket dimensions for helmets in combination with maximum speakers thickness. It should be analysed specially for full face helmets, if not we could risk that an UA helmet with an approved universal accessory with speakers might not be worn because of dimensional limitations.

If this is not taken into account, final users will dig on EPS if they find it hurts or feel not to be comfortable.

Need to minimise this to happen.

5. If a helmet is marked as UA for different installing positions, all of the positions must be prepared to be used at the same time. Need to add prescription at new paragraph 6.3.1.10

6. Risk assessment needed:

Propose practical cases and do round robin tests to evaluate whether the interpretation of the Regulation will be the same among key relevant TS.

### **Regarding risk assessment and product liability**

At this stage ONLY accessories tested during the homologation can be considered safe.

For the rest of the aftermarket product there is no evidence that the performance of the helmet will stay within the limit of the standard when the accessory is installed.