

---

## Proposal for the 01 series of amendments to UN Regulation No. 136 (specific requirements for the electric power train of vehicles of category L)

### Submitted by the expert from IMMA

The text reproduced below was prepared by the experts from IMMA to amend the provisions concerning the approval of vehicles of category L with regard to specific requirements for the electric power train, to introduce updated provisions from the new 03 series of amendments to UN Regulation No. 100 (ECE/TRANS/WP.29/2020/109), adopted by WP.29 at its 182<sup>nd</sup> session in November 2020.

## I. Proposal

*Text of the UN Regulation,*

*Through all text of the Regulation (including all Annexes), tested-device, amend to read:*  
**Tested-Device.**

*Paragraphs 1.1. to 1.2., amend to read:*

"1.1. Part I: Safety requirements with respect to the electric power train of vehicles of category L<sup>1</sup> with a maximum design speed exceeding 6 km/h, equipped with **an electric power train, excluding vehicles permanently connected to the grid** ~~one or more traction motor(s) operated by electric power and not permanently connected to the grid, as well as their high voltage components and systems which are galvanically connected to the high voltage bus of the electric power train.~~

**Part I of this regulation does not cover high voltage components and systems which are not galvanically connected to the high voltage bus of the electric power train.**

1.2. Part II: Safety requirements with respect to the Rechargeable Electrical Energy Storage System (REESS) of vehicles of category L with a maximum design speed exceeding 6 km/h, equipped with **an electric power train, excluding vehicles** ~~one or more traction motors operated by electric power and not permanently connected to the grid.~~

Part II of this Regulation does not apply to **a battery REESS(s)** whose primary use is to supply power for starting the engine and/or lighting and/or other vehicle auxiliaries' systems."

*Paragraph 2.2., shall be deleted.*

*Insert new paragraphs 2.2. to 2.4., to read:*

"2.2. **"Aqueous electrolyte"** means an electrolyte based on water solvent for the compounds (e.g. acids, bases) providing conducting ions after its dissociation.

2.3. **"Automatic disconnect"** means a device that when triggered, conductively separates the electric energy sources from the rest of the high voltage circuit of the electric power train.

---

<sup>1</sup> As defined in the Consolidated Resolution on the Construction of Vehicles (R.E.3.), document ECE/TRANS/WP.29/78/Rev.3, para. 2. - [www.unece.org/trans/main/wp29/wp29wgs/wp29gen/wp29resolutions.html](http://www.unece.org/trans/main/wp29/wp29wgs/wp29gen/wp29resolutions.html)

**2.4. "Breakout harness" means connector wires that are connected for testing purposes to the REESS on the traction side of the automatic disconnect."**

*Paragraph 2.3. (former), renumber as paragraph 2.5.*

*Paragraph 2.4. (former), renumber as paragraph 2.6. and amend to read:*

**"2.6. "Cell" means a single enclosed electrochemical unit containing one positive and one negative terminals-electrode, which exhibits a voltage differential across its two terminals and used as rechargeable electrical energy storage device."**

*Paragraph 2.5. (former), shall be deleted.*

*Paragraph 2.6. (former), renumber as paragraph 2.7.*

*Insert new paragraph 2.8., to read:*

**"2.8. "Connector" means the device that provides mechanical connection and disconnection of high voltage electrical conductors to a suitable mating component including its housing."**

*Paragraphs 2.7. and 2.8. (former), renumber as paragraphs 2.9. to 2.10.*

*Paragraph 2.9. (former), renumber as paragraph 2.11., and amend to read:*

**"2.11. "Direct contact" means the contact of persons with high voltage live parts."**

*Paragraphs 2.10. and 2.11. (former), renumber as paragraphs 2.12. to 2.13.*

*Paragraph 2.12. (former), renumber as paragraph 2.14., and amend to read:*

**"2.14. "Electrical circuit" means an assembly of connected high voltage live parts which is designed to be electrically energized in normal operation."**

*Paragraph 2.13. (former), renumber as paragraph 2.15., and amend to read:*

**"2.15. "Electric energy conversion system" means a system (e.g. fuel cell) that generates and provides electric energy for electric propulsion."**

*Paragraph 2.14. (former), renumber as paragraph 2.16., and amend to read:*

**"2.16. "Electric power train" means the electrical circuit which includes the traction motor(s), and may also include the REESS, the electric energy conversion system, the electronic converters, the associated wiring harness and connectors, and the coupling system for charging the REESS."**

*Insert new paragraphs 2.17. to 2.18., to read:*

**"2.17. "Electrical protection barrier" means the part that provides protection against direct contact with the high voltage live parts.**

**2.18. "Electrolyte leakage" means the escape of electrolyte from the REESS in the form of liquid."**

*Paragraph 2.15. (former), renumber as paragraph 2.19.*

*Paragraph 2.16. (former), renumber as paragraph 2.20., and amend to read:*

**"2.20. "Enclosure" means the part enclosing the internal units and providing protection against any direct contact from any direction of access."**

*Paragraph 2.17. (former), renumber as paragraph 2.21., and amend to read:*

**"2.21. "Exposed conductive part" means the conductive part which can be touched under the provisions of the protection degree IPXXB, and which is not normally energized, but which can become becomes electrically energized under isolation failure conditions. This includes parts under a cover that can be removed without using tools."**

*Paragraph 2.18. (former), renumber as paragraph 2.22.*

*Paragraphs 2.19. to 2.22. (former), renumber as paragraphs 2.23. to 2.26.*

Paragraph 2.23. (former), renumber as paragraph 2.27. and amend to read:

"2.27. "High voltage bus" means the electrical circuit, including the coupling system for charging the REESS that operates on high voltage. ~~Where In case of electrical circuits, that are galvanically connected to each other are galvanically connected to the electrical chassis and the maximum voltage between any live part and the electrical chassis or any exposed conductive part is  $\leq 30$  V AC and  $\leq 60$  V DC, and fulfilling the voltage condition specified in paragraph 2.47.,~~ only the components or parts of the electric circuit that operate on high voltage are classified as a high voltage bus."

Paragraph 2.24. (former), renumber as paragraph 2.28.

Paragraph 2.25. (former), renumber as paragraph 2.29., and amend to read:

"2.29. "Live parts" means the conductive part(s) intended to be electrically energized **under normal operating conditions** ~~in normal use.~~"

Paragraph 2.26. (former), renumber as paragraph 2.30.

Paragraph 2.27. (former), renumber as paragraph 2.31., and amend to read:

"2.31. "Manufacturer" means the person or body who is responsible to the approval authority for all aspects of the ~~type~~ approval process and for ensuring conformity of production. It is not essential that the person or body ~~be~~ is directly involved in all stages of the construction of the vehicle, ~~system~~ or component which is the subject of the approval process."

Insert new paragraphs 2.32. to 2.33., to read:

"2.32. "Non-aqueous electrolyte" means an electrolyte not based on water as the solvent.

2.33. "Normal operating conditions" includes operating modes and conditions that can reasonably be encountered during typical operation of the vehicle including driving at legally posted speeds, parking and standing in traffic, as well as, charging using chargers that are compatible with the specific charging ports installed on the vehicle. It does not include conditions where the vehicle is damaged, either by a crash, road debris or vandalism, unintentional fall, subjected to fire or water submersion, or in a state where service and or maintenance is needed or being performed."

Paragraph 2.28. (former), renumber as paragraph 2.34.

Paragraphs 2.29. to 2.30. (former), renumber as paragraphs 2.35. to 2.36., and amend to read:

"2.35. "Open type traction battery" means a ~~liquid~~ type of battery requiring refilling with ~~water~~ liquid and generating hydrogen gas that is released to the atmosphere.

2.36. "Passenger compartment" means the space for occupant accommodation, bounded by at least 4 of the following: the roof, floor, side walls, doors, ~~window glass~~ outside glazing, front bulkhead and rear bulkhead, or rear gate, as well as by the electrical protection barriers and enclosures provided for protecting the occupants from direct contact with high voltage live parts."

Paragraph 2.31. (former), shall be deleted.

Insert new paragraphs 2.37. and 2.38., to read:

"2.37. "Protection degree IPXXB" means protection from contact with high voltage live parts provided by either an electrical protection barrier or an enclosure and tested using a Jointed Test Finger (IPXXB) as described in Annex 3.

**2.38. "Protection degree IPXXD" means protection from contact with high voltage live parts provided by either an electrical protection barrier or an enclosure and tested using a Test Wire (IPXXD) as described in Annex 3."**

*Paragraph 2.32. (former), renumber as paragraph 2.39. and amend to read:*

**"2.39. "Rechargeable Electrical Energy Storage System (REESS)" means the rechargeable energy storage system that provides electric energy for electric propulsion.**

**A battery whose primary use is to supply power for starting the engine and/or lighting and/or other vehicle auxiliaries' systems is not considered as a REESS.**

**The REESS may include subsystem(s) together with the necessary ancillary systems for physical support, thermal management, electronic controls and enclosures/casing."**

*Insert new paragraph 2.40., to read:*

**"2.40. "REESS subsystem" means any assembly of REESS components which stores energy. A REESS subsystem may or may not include the entire management system of the REESS."**

*Paragraphs 2.33. to 2.37. (former), renumber as paragraphs 2.41. to 2.45.*

*Paragraph 2.38. (former), renumber as paragraph 2.46., and amend to read:*

**"2.46. "Solid insulator" means the insulating coating of wiring harnesses provided in order to cover and prevent the high voltage protect the live parts from any against direct contact from any direction of access; covers for insulating the live parts of connectors, and varnish or paint for the purpose of insulation."**

*Insert new paragraph 2.47., to read:*

**"2.47. "Specific voltage condition" means the condition that the maximum voltage of a galvanically connected electrical circuit between a DC live part and any other live part (DC or AC) is  $\leq 30$  V AC (rms) and  $\leq 60$  V DC.**

**Note: When a DC live part of such an electrical circuit is connected to electrical chassis and the specific voltage condition applies, the maximum voltage between any live part and the electrical chassis is  $\leq 30$  V AC (rms) and  $\leq 60$  V DC."**

*Paragraph 2.39. (former), shall be deleted.*

*Paragraph 2.40. (former), renumber as paragraph 2.48.*

*Paragraph 2.41. (former), renumber as paragraph 2.49., and amend to read:*

**"2.49. "Tested device/Tested-Device" means either the complete REESS or the REESS subsystem of a REESS that is subjected to the tests prescribed by this Regulation."**

*Insert new paragraphs 2.50. to 2.52., to read:*

**"2.50. "Thermal event" means the condition when the temperature within the REESS is significantly higher (as defined by the manufacturer) than the maximum operating temperature.**

**2.51. "Thermal runaway" means an uncontrolled increase of cell temperature caused by exothermic reactions inside the cell.**

**2.52. "Thermal propagation" means the sequential occurrence of thermal runaway within a REESS triggered by thermal runaway of a cell in that REESS."**

*Paragraph 2.42. (former), renumber as paragraph 2.53.*

*Insert new paragraphs 2.54. to 2.55., to read:*

"2.54. **"Vehicle connector" means the device which is inserted into the vehicle inlet to supply electric energy to the vehicle from an external electric power supply.**

2.55. **"Vehicle inlet" means the device on the externally chargeable vehicle into which the vehicle connector is inserted for the purpose of transferring electric energy from an external electric power supply."**

*Paragraph 2.43. (former), renumber as paragraph 2.56.*

*Insert new paragraph 2.57., to read:*

"2.57. **"Venting" means the release of excessive internal pressure from cell or REESS subsystem or REESS in a manner intended by design to preclude rupture or explosion."**

*Paragraphs 2.44. to 2.45. (former), renumber as paragraphs 2.58. to 2.59.*

*Paragraph 3.1., amend to read:*

"3.1. Part I: Approval of a vehicle type with regard to **specific requirements for the electric power train**~~its electrical safety, including the High Voltage System.~~"

*Paragraph 3.1.2.1., amend to read:*

"3.1.2.1. Detailed description of the vehicle type **as with regards to** the electric power train and the ~~galvanically connected~~ high voltage bus **galvanically connected to it."**

*Paragraph 3.2.1., amend to read:*

"3.2.1. The application for approval of a type of REESS ~~or separate technical unit~~ with regard to the safety requirements of the REESS shall be submitted by the REESS manufacturer or by his duly accredited representative."

*Paragraph 3.2.2.1., amend to read:*

"3.2.2.1. Detailed description of the type of REESS ~~or separate technical unit~~ **with regards to** the safety of the REESS."

*Paragraph 4.2., amend to read:*

"4.2. An approval number shall be assigned to each type approved **in accordance with Schedule 4 of the Agreement (E/ECE/TRANS/505/Rev.3)**. ~~Its first two digits (at present 02 for the Regulation in its form) shall indicate the series of amendments incorporating the most recent major technical amendments made to the Regulation at the time of issue of the approval. The same Contracting Party shall not assign the same number to another vehicle type."~~

*Paragraph 4.4., amend to read:*

"4.4. There shall be affixed, conspicuously and in a readily accessible place specified on the approval form, to every vehicle or REESS ~~or separate technical unit~~ conforming to a type approved under this Regulation an international approval mark consisting of:"

*Paragraph 4.4.3., amend to read:*

"4.4.3. In the case of an approval of a REESS ~~or a separate technical unit of the REESS~~ the "R" shall be followed by the symbol "ES"."

*Paragraph 4.6.2., amend to read:*

"4.6.2. In the case of a REESS ~~or separate technical unit approved as a REESS~~, the approval mark shall be affixed on the major element of the REESS by the manufacturer."

*Paragraphs 5. to 5.1.1.4., amend to read:*

**"5. Part I: Requirements of a vehicle with regard to specific requirements for the electric power train its electrical safety**

5.1. Protection against electrical shock

These electrical safety requirements apply to high voltage buses **of electric power train and electrical components which are galvanically connected to the high voltage bus of electric power train** under conditions where they are not connected to external high voltage power supplies.

5.1.1. Protection against direct contact

~~Protection against direct contact with high voltage live parts is also required for vehicles equipped with any REESS type approved under Part II of this Regulation.~~

The protection against direct contact with the **high voltage** live parts, shall comply with paragraphs 5.1.1.1. and 5.1.1.2.

These protections (solid insulator, **electrical protection** barrier, enclosure, etc.) shall not be able to be opened, disassembled or removed without the use of tools.

5.1.1.1. For ~~protection of high voltage~~ live parts inside the passenger compartment or luggage compartment, the protection degree IPXXD shall be provided.

5.1.1.2. For ~~protection of high voltage~~ live parts in areas other than the passenger compartment or luggage compartment:

5.1.1.2.1. For vehicles with a passenger compartment, the protection degree IPXXB shall be ~~satisfied~~**provided**.

5.1.1.2.2. For vehicles without passenger compartment, the protection degree IPXXD shall be ~~satisfied~~**provided**.

5.1.1.3. Connectors

Connectors (including **the** vehicle inlet) are deemed to meet this requirement if:

(a) They comply with 5.1.1.1. and 5.1.1.2. when separated without the use of tools; or

~~(b) They are located underneath the floor and are provided with a locking mechanism; or~~

**(be)** They are provided with a locking mechanism **(at least two distinct actions are needed to separate the connector from its mating component)**. **Additionally, and other components, not being part of the connector,** shall be removed with the use of tools, in order to separate the connector; or

~~(cd)~~ The voltage of the live parts becomes equal or below 60 V DC or equal or below 30 V AC (rms) within one second after the connector is separated.

5.1.1.4. Service disconnect

For a **high voltage** service disconnect which can be opened, disassembled or removed without tools, ~~it is acceptable if~~ protection degree IPXXB ~~is~~**shall be** satisfied ~~under a condition where~~ **when** it is opened, disassembled or removed. ~~without tools.~~

5.1.1.5. Marking

5.1.1.5.1. ~~In the case of a REESS having high voltage capability~~ ~~†~~The symbol shown in Figure 1 shall ~~be present~~**appear** on or near the REESS **having high voltage**

**capability.** The symbol background shall be yellow, the bordering and the arrow shall be black.

**This requirement shall also apply to a REESS which is part of a galvanically connected electrical circuit where the specific voltage condition is not fulfilled, independent of the maximum voltage of the REESS.**

Figure 1  
**Marking of High Voltage Equipment**

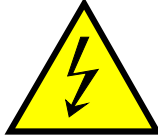

5.1.1.5.2. The symbol shall also be visible on enclosures and **electrical protection** barriers, which, when removed expose live parts of high voltage circuits. This provision is optional to any connector for high voltage buses. This provision shall not apply to any of the following cases:

- (a) Where **electrical protection** barriers or enclosures cannot be physically accessed, opened, or removed; unless other vehicle components are removed with the use of tools;
- (b) Where **electrical protection** barriers or enclosures are located underneath the vehicle floor."

*Paragraphs 5.1.2. to 5.1.2.3., amend to read:*

"5.1.2. Protection against indirect contact

~~Protection against indirect contact is also required for vehicles with high voltage live parts equipped with any REESS type approved under Part II of this Regulation.~~

5.1.2.1. For protection against electrical shock which could arise from indirect contact, the exposed conductive parts, such as the conductive **electrical protection** barrier and enclosure, shall be galvanically connected securely to the electrical chassis by connection with electrical wire or ground cable, or by welding, or by connection using bolts, etc. so that no dangerous potentials are produced.

5.1.2.2. The resistance between all exposed conductive parts and the electrical chassis shall be lower than 0.1  $\Omega$  when there is current flow of at least 0.2 A.

**The resistance between any two simultaneously reachable exposed conductive parts of the electrical protection barriers that are less than 2.5 m from each other shall not exceed 0.2  $\Omega$ . This resistance may be calculated using the separately measured resistances of the relevant parts of electric path.**

This requirement is satisfied if the galvanic connection has been established by welding. **In case of doubt or if the connection is established by other means than welding, a measurement shall be made by using one of the test procedures described in Annex 4.**

5.1.2.3. In the case of motor vehicles which are intended to be connected to the grounded external electric power supply through the conductive connection, a device to enable the galvanical connection of the electrical chassis to the earth ground **for the external electric power supply** shall be provided.

The device shall enable connection to the earth ground before exterior voltage is applied to the vehicle and retain the connection until after the exterior voltage is removed from the vehicle.

Compliance to this requirement ~~shall~~**may** be demonstrated either by using the connector specified by the vehicle manufacturer, **by visual inspection or drawings** ~~or by analysis~~.

**The above requirements are only applicable for vehicles when charging from a stationary charging point, with a charging cable of finite length, through a vehicle coupler."**

*Paragraph 5.1.2.4.1.1., amend to read:*

"5.1.2.4.1.1. For vehicle with on-board charger the test shall be conducted according to Annex ~~9A~~ **10A** to this regulation."

*Paragraph 5.1.2.4.2.1., amend to read:*

"5.1.2.4.2.1. This test shall be conducted according to Annex ~~9B~~ **10B** of this regulation."

*Paragraphs 5.1.3. to 5.1.3.4., amend to read:*

"5.1.3. Isolation resistance

This paragraph shall not apply to ~~chassis connected~~ electrical circuits **that are galvanically connected to each other**, where **the DC part of these circuits is connected to the electrical chassis and the specific voltage condition is fulfilled**.~~the maximum voltage between any live part and the electrical chassis or any exposed conductive part does not exceed 30V AC (rms) or 60 V DC.~~

5.1.3.1. Electric power train consisting of separate Direct Current (DC)- or Alternating Current (AC)-buses

...

The measurement shall be conducted according to Annex ~~4A-5A~~ "Isolation resistance measurement method for vehicle based tests".

5.1.3.2. Electric power train consisting of combined DC- and AC-buses

...

(a) ~~At least two~~**Double** or more layers of solid insulators, **electrical protection** barriers or enclosures that meet the requirement in paragraph 5.1.1. independently, for example wiring harness;

(b) Mechanically robust protections that have sufficient durability over vehicle service life such as motor housings, electronic converter cases or connectors;

...

The measurement shall be conducted according to Annex ~~4A~~ **5A** "Isolation resistance measurement method for vehicle based tests".

5.1.3.3. Fuel cell vehicles

**In fuel cell vehicles, DC high voltage buses shall have an on-board isolation resistance monitoring system together with a warning to the driver if the isolation resistance drops below the minimum required value of 100 Ω/V. The function of the on-board isolation resistance monitoring system shall be confirmed as described in Annex 6.**

**The isolation resistance between the high voltage bus of the coupling system for charging the REESS, which is not energized in conditions other than that during the charging of the REESS, and the electrical chassis need not to be monitored.**

~~If the minimum isolation resistance requirement cannot be maintained over time, then protection shall be achieved by any of the following:~~

(a) ~~Double or more layers of solid insulators, barriers or enclosures that meet the requirement in paragraph 5.1.1. independently;~~



~~(b) — On board isolation resistance monitoring system together with a warning to the driver if the isolation resistance drops below the minimum required value. The isolation resistance between the high voltage bus of the coupling system for charging the REESS, which is not energized besides during charging the REESS, and the electrical chassis need not be monitored. The function of the on board isolation resistance monitoring system shall be confirmed as described in Annex 5.~~

5.1.3.4. Isolation resistance requirement for the coupling system used to charge the REESS

~~For the coupling system (used to charge the REESS and intended to be conductively connected to the grounded external AC power supply) the isolation resistance shall be at least 1 M $\Omega$  when the charger coupler is disconnected. During the measurement, the REESS may be disconnected.~~

**For the vehicle conductive connection device intended to be conductively connected to the grounded external AC power supply and the electrical circuit that is galvanically connected to the vehicle conductive connection device during charging of the REESS, the isolation resistance between the high voltage bus and the electrical chassis shall be minimum 500  $\Omega$ /V when the conductive connection is disconnected and the isolation resistance is measured at the high voltage live parts (contacts) of the vehicle conductive connection device. During the measurement, the REESS may be disconnected."**

*Insert new Paragraphs 5.1.4. to 5.1.4.4., to read:*

**"5.1.4. Protection against water effects.**

**The vehicles shall maintain isolation resistance after exposure to water (e.g. washing, driving through standing water). This paragraph shall not apply to electrical circuits that are galvanically connected to each other, where the DC part of these circuits is connected to the electrical chassis and the specific voltage condition is fulfilled.**

**5.1.4.1. The vehicle manufacturer can choose to comply with requirements specified in paragraph 5.1.4.2., or those specified in paragraph 5.1.4.3., or those specified in paragraph 5.1.4.4.**

**5.1.4.2. The vehicle manufacturers shall provide evidence and/or documentation to the Type Approval Authority or Technical Service as applicable on how the electrical design or the components of the vehicle located outside the passenger compartment or externally attached, after water exposure remain safe and comply with the requirements described in Annex 7A. If the evidence and/or documentation provided is not satisfactory the Type Approval Authority or Technical Service as applicable shall require the manufacturer to perform a physical component test based on the same specifications as those described in Annex 7A.**

**5.1.4.3. If the test procedures specified in Annex 7B are performed, just after each exposure, and with the vehicle still in wet condition, the vehicle shall undergo isolation resistance test given in Annex 5A, and shall comply with the isolation resistance requirements given in paragraph 5.1.3. Subsequently, after a 24 hour pause, the isolation resistance test as specified in Annex 5A shall be performed again, and the isolation resistance requirements given in paragraph 5.1.3. shall be met.**

**5.1.4.4. If an isolation resistance monitoring system is provided, and the isolation resistance less than the requirements given in paragraph 5.1.3. is detected, a warning shall be indicated to the driver. The function of the on-board isolation resistance monitoring system shall be confirmed as described in Annex 6."**

Paragraphs 5.2. to 5.2.1.2., amend to read:

- "5.2.           **Rechargeable Electrical Energy Storage System (REESS)**
- 5.2.1.           For a vehicle with a REESS, the requirement of either paragraph 5.2.1.1. or paragraph 5.2.1.2. shall be satisfied.
- 5.2.1.1.        For a REESS which has been type approved in accordance with Part II of this **series of Amendments to this Regulation**, installation shall be in accordance with the instructions provided by the manufacturer of the REESS, and in conformity with the description provided ~~in Part 2 of Annex 6~~ **Annex 1 Appendix 2** to this Regulation.
- 5.2.1.2.        The REESS **including related vehicle components, systems and structure as applicable**, shall comply with the respective requirements of paragraph 6. of this Regulation."

Insert new paragraphs 5.2.5. to 5.2.6., to read:

- "5.2.5.           **Warning in the event of failure in REESS**
- The vehicle shall provide a warning to the driver when the vehicle is in active driving possible mode in the event specified in paragraphs 6.13. to 6.15., if applicable.**
- In case of optical warning, the tell-tale shall, when illuminated, be sufficiently bright to be visible to the driver under both daylight and night-time driving conditions, when the driver has adapted to the ambient roadway light conditions.**
- This tell-tale shall be activated as a check of lamp function either when the propulsion system is turned to the "On" position, or when the propulsion system is in a position between "On" and "Start" that is designated by the manufacturer as a check position. This requirement does not apply to the tell-tale or text shown in a common space.**
- 5.2.6.           **Warning in the event of low energy content of REESS.**
- For pure electric vehicles (vehicles equipped with a powertrain containing exclusively electric machines as propulsion energy converters and exclusively rechargeable electric energy storage systems as propulsion energy storage systems), a warning to the driver in the event of low REESS state of charge shall be provided. Based on engineering judgment, the manufacturer shall determine the necessary level of REESS energy remaining, when the driver warning is first provided.**
- In case of optical warning, the tell-tale shall, when illuminated, be sufficiently bright to be visible to the driver under both daylight and night-time driving conditions, when the driver has adapted to the ambient roadway light conditions."**

Paragraphs 5.3. to 5.3.1.4. (former), renumber and amend to read:

- "5.3.           **Preventing accidental or unintended vehicle movement** ~~Functional safety~~
- ~~A momentary indication shall, as minimum, be given to the driver when the vehicle is in "active driving possible mode".~~
- 5.3.1.           **At least a momentary indication shall be given to the driver each time when the vehicle is first placed in "active driving possible mode" after activation of the propulsion system.**
- However, this provision ~~does not apply~~ **is optional** under conditions where an internal combustion engine directly or indirectly provides the vehicle's propulsion power **upon vehicle start up.**
- 5.3.2.           When leaving the vehicle, the driver shall be informed by a signal (e.g. optical or audible signal) if the vehicle is still in the active driving possible mode.

**However, this provision is optional under conditions where an internal combustion engine provides directly or indirectly the vehicle's propulsion power while leaving the vehicle or driver seat.**

- 5.3.3. If the ~~onboard~~ REESS can be externally charged ~~by the user~~, vehicle movement caused by the vehicle's propulsion system shall not be possible while the **vehicle connector** ~~external electric power supply~~ is physically connected to the vehicle inlet.

...

This requirement shall be demonstrated by using the **vehicle** connector specified by the vehicle manufacturer. The state of the drive direction control unit shall be identified to the driver.

- 5.3.14. Additional functional safety requirements
- 5.3.14.1. At least two deliberate and distinctive actions shall be performed by the driver at the start-up to select the active driving possible mode.
- 5.3.14.2. Only a single action shall be required to deactivate the active driving possible mode.
- 5.3.14.3. Indication of temporary reduced power (i.e. not resulting from a failure) ~~and/or of state of charge (SOC) of REESS.~~
- 5.3.14.3.1. The vehicle shall have a function/device that indicates to the driver/~~rider~~ if the power is automatically reduced below a certain level, (e.g. due to activation of the output controller to protect the REESS or the propulsion system or due to a low SOC).
- 5.3.14.3.2. The conditions under which these indications are given shall be determined by the manufacturer.
- A brief description of the power reduction and indicating strategy will be prescribed in ~~Annex 6~~ **Annex 1 Appendix 1**.
- 5.3.14.4. Driving or riding backwards
- It shall not be possible to activate the vehicle reverse control function whilst the vehicle is in forward motion."

*Paragraphs 5.4.2. to 5.4.4., amend to read:*

- "5.4.2. The test ... in Annex ~~78~~ to ~~the present~~ **this** Regulation. ...
- 5.4.3. During ... in Annex ~~78~~, hydrogen ...
- 5.4.4. During ... a failure (conditions given in Annex ~~78~~), hydrogen ..."

*Paragraph 5.4.10., amend to read:*

- "5.4.10. This approval ... given in Annex ~~78~~, Appendix 2."

*Paragraph 6.1., amend to read:*

- "6.1. General
- The procedures ... in Annex ~~98~~ of ..."

*Paragraph 6.2.1., amend to read:*

- "6.2.1. This test ... with Annex ~~9A-8A~~ to this Regulation.
- A REESS that passes the vibration test in all three mutually perpendicular X, Y and Z directions may be mounted in any orientation on the vehicle."**

*Paragraphs 6.2.2.1. to 6.2.2.2., amend to read:*

- "6.2.2.1. During the test, there shall be no evidence of:
- (a) Electrolyte leakage;

- (b) Rupture (applicable to high voltage REESS (s) only);
- (c) **Venting (for REESS other than open-type traction battery);**
- (d) Fire;
- (~~e~~) Explosion.

**The evidence of REESS venting shall be verified only for vehicles with a passenger compartment.**

**The evidence of electrolyte leakage shall be verified by visual inspection without disassembling any part of the ~~tested device~~ Tested-Device. An appropriate technique shall, if necessary, be used in order to confirm if there is any electrolyte leakage from the REESS resulting from the test. The evidence of venting shall be verified by visual inspection without disassembling any part of the Tested-Device.**

- 6.2.2.2. For a high voltage REESS, the isolation resistance measured after the test in accordance with Annex ~~5B-4B~~ to this Regulation shall not be less than 100 Ω/Volt."

*Paragraph 6.3.1.*, amend to read:

"6.3.1. This test ... with Annex ~~9B-8B~~ to this Regulation."

*Paragraphs 6.3.2.1. to 6.3.2.2.*, amend to read:

"6.3.2.1. During the test, there shall be no evidence of:

- (a) Electrolyte leakage;
- (b) Rupture (applicable to high voltage REESS (s) only);
- (c) **Venting (for REESS other than open-type traction battery);**
- (d) Fire;
- (~~e~~) Explosion.

**The evidence of REESS venting shall be verified only for vehicles with a passenger compartment.**

**The evidence of electrolyte leakage shall be verified by visual inspection without disassembling any part of the ~~tested device~~ Tested-Device. An appropriate technique shall, if necessary, be used in order to confirm if there is any electrolyte leakage from the REESS resulting from the test. The evidence of venting shall be verified by visual inspection without disassembling any part of the Tested-Device.**

- 6.3.2.2. For a high voltage REESS, the isolation resistance measured after the test in accordance with Annex ~~5B-4B~~ to this Regulation shall not be less than 100 Ω/Volt."

*Paragraphs 6.4.1.1 to 6.4.1.2.2.*, amend to read:

"6.4.1.1. The test shall be conducted in accordance with Annex ~~9B~~C of this Regulation."

6.4.1.2. Acceptance criteria

6.4.1.2.1. During the test there shall be no evidence of

- (a) Electrolyte leakage;
- (b) Rupture (applicable to high voltage REESS(s) only);
- (c) **Venting (for REESS other than open-type traction battery);**
- (d) Fire;
- (~~e~~) Explosion.

**The evidence of REESS venting shall be verified only for vehicles with a passenger compartment.**

**The evidence of electrolyte leakage shall be verified by visual inspection without disassembling any part of the ~~tested device~~ Tested-Device. An appropriate technique shall, if necessary, be used in order to confirm if there is any electrolyte leakage from the REESS resulting from the test. The evidence of venting shall be verified by visual inspection without disassembling any part of the Tested-Device.**

- 6.4.1.2.2. For a high voltage REESS, the isolation resistance measured after the test in accordance with ~~Annex 4B~~ **Annex 5B** of this Regulation shall not be less than 100  $\Omega$  / Volt."

*Paragraphs 6.4.2.1. to 6.4.2.2.2., amend to read:*

- "6.4.2.1. This test shall apply to vehicles with a centre and/or side stand.  
The test shall be conducted in accordance with Annex ~~9D~~ **D** of this Regulation.

6.4.2.2. Acceptance criteria

- 6.4.2.2.1. During the test there shall be no evidence of

- (a) Electrolyte leakage;
- (b) Rupture (applicable to high voltage REESS(s) only);
- (c) **Venting (for REESS other than open-type traction battery);**
- (d) Fire;
- ~~(e)~~ Explosion.

**The evidence of REESS venting shall be verified only for vehicles with a passenger compartment.**

**The evidence of electrolyte leakage shall be verified by visual inspection without disassembling any part of the ~~tested device~~ Tested-Device. An appropriate technique shall, if necessary, be used in order to confirm if there is any electrolyte leakage from the REESS resulting from the test. The evidence of venting shall be verified by visual inspection without disassembling any part of the Tested-Device.**

- 6.4.2.2.2. For a high voltage REESS the isolation resistance of the ~~tested device~~ **Tested-Device** shall ensure at least 100  $\Omega$ /Volt for the whole REESS measured after the test in accordance with Annex ~~45B~~ **B** to this Regulation."

*Paragraphs 6.5.1. to 6.5.2., amend to read:*

- "6.5.1. Vehicle based test  
The test ... with Annex ~~89E~~ **E** in due consideration of paragraph 3.2.1. of Annex ~~98E~~ **E**.

...

- 6.5.2. Component based test  
The test ... with Annex ~~89E~~ **E** in due consideration of paragraph 3.2.2. of Annex ~~98E~~ **E**."

*Paragraph 6.6.1., amend to read:*

- "6.6.1. The test ... with Annex ~~89F~~ **F** of this Regulation."

*Paragraphs 6.6.2.1. to 6.6.2.2., amend to read:*

- "6.6.2.1. During the test there shall be no evidence of:  
(a) Electrolyte leakage;

- (b) Rupture (applicable to high voltage REESS(s) only);
- (c) **Venting (for REESS other than open-type traction battery);**
- (d) Fire;
- (~~e~~) Explosion.

**The evidence of REESS venting shall be verified only for vehicles with a passenger compartment.**

**The ~~e~~Evidence of electrolyte leakage shall be verified by visual inspection without disassembling any part of the ~~tested device~~Tested-Device. An appropriate technique shall, if necessary, be used in order to confirm if there is any electrolyte leakage from the REESS resulting from the test. The evidence of venting shall be verified by visual inspection without disassembling any part of the Tested-Device."**

6.6.2.2. For a high voltage ...with Annex ~~4B5B~~ to this Regulation shall not ..."

*Paragraph 6.7.1.*, amend to read:

"6.7.1. The test ... with Annex ~~89G~~ of this Regulation."

*Paragraphs 6.7.2.1. to 6.7.2.2.*, amend to read:

"6.7.2.1. During the test there shall be no evidence of:

- (a) Electrolyte leakage;
- (b) Rupture (applicable to high voltage REESS(s) only);
- (c) **Venting (for REESS other than open-type traction battery);**
- (d) Fire;
- (~~e~~) Explosion.

**The evidence of REESS venting shall be verified only for vehicles with a passenger compartment.**

**The ~~e~~Evidence of electrolyte leakage shall be verified by visual inspection without disassembling any part of the ~~tested device~~Tested-Device. An appropriate technique shall, if necessary, be used in order to confirm if there is any electrolyte leakage from the REESS resulting from the test. The evidence of venting shall be verified by visual inspection without disassembling any part of the Tested-Device."**

6.7.2.2. For a high voltage ...with Annex ~~4B5B~~ to this Regulation shall not ..."

*Paragraph 6.8.1.*, amend to read:

"6.8.1. The test ... with Annex ~~89H~~ of this Regulation."

*Paragraphs 6.8.2.1. to 6.8.2.2.*, amend to read:

"6.8.2.1. During the test there shall be no evidence of:

- (a) Electrolyte leakage;
- (b) Rupture (applicable to high voltage REESS(s) only);
- (c) **Venting (for REESS other than open-type traction battery);**
- (d) Fire;
- (~~e~~) Explosion.

**The evidence of REESS venting shall be verified only for vehicles with a passenger compartment.**

**The ~~e~~Evidence of electrolyte leakage shall be verified by visual inspection without disassembling any part of the ~~tested device~~Tested-Device. An appropriate technique shall, if necessary, be used in order to confirm if**

**there is any electrolyte leakage from the REESS resulting from the test. The evidence of venting shall be verified by visual inspection without disassembling any part of the Tested-Device."**

6.8.2.2. For a high voltage ...with Annex ~~4B5B~~ to this Regulation shall not ..."

*Paragraph 6.9.1.*, amend to read:

"6.9.1. The test ... with Annex ~~89I~~ of this Regulation."

*Paragraphs 6.9.2.1. to 6.9.2.2.*, amend to read:

"6.9.2.1. During the test there shall be no evidence of:

- (a) Electrolyte leakage;
- (b) Rupture (applicable to high voltage REESS(s) only);
- (c) **Venting (for REESS other than open-type traction battery);**
- (d) Fire;
- (~~e~~) Explosion.

**The evidence of REESS venting shall be verified only for vehicles with a passenger compartment.**

**The evidence of electrolyte leakage shall be verified by visual inspection without disassembling any part of the ~~tested-device~~ Tested-Device. An appropriate technique shall, if necessary, be used in order to confirm if there is any electrolyte leakage from the REESS resulting from the test. The evidence of venting shall be verified by visual inspection without disassembling any part of the Tested-Device.**

6.9.2.2. For a high voltage ...with Annex ~~4B5B~~ to this Regulation shall not ..."

*Paragraphs 6.10. to 6.10.2. (former)*, shall be deleted

*Insert new paragraphs 6.10. to 6.15.2.4.3.*, to read:

**6.10. Overcurrent protection**

**This test is required for REESS intended for use on vehicles that have the capability of charging by DC external electricity supply.**

**6.10.1. The test shall be conducted in accordance with Annex 9J to this Regulation.**

**6.10.2. Acceptance criteria**

**6.10.2.1. During the test there shall be no evidence of:**

- (a) Electrolyte leakage;
- (b) Rupture (applicable to high voltage REESS(s) only);
- (c) **Venting (for REESS other than open-type traction battery);**
- (d) Fire;
- (e) Explosion.

**The evidence of REESS venting shall be verified only for vehicles with a passenger compartment.**

**The evidence of electrolyte leakage shall be verified by visual inspection without disassembling any part of the Tested-Device. An appropriate technique shall, if necessary, be used in order to confirm if there is any electrolyte leakage from the REESS resulting from the test. The evidence of venting shall be verified by visual inspection without disassembling any part of the Tested-Device.**

- 6.10.2.2.** The overcurrent protection control of the REESS shall terminate charging or the temperature measured on the casing of the REESS shall be stabilized, such that the temperature gradient varies by less than 4 °C through 2 hours after the maximum overcurrent charging level is reached.
- 6.10.2.3.** For a high voltage REESS, the isolation resistance measured after the test in accordance with Annex 5B to this Regulation shall not be less than 100 Ω/V.
- 6.11.** **Low-temperature protection.**
- REESS manufacturer must make available, at the request of the Technical Service with its necessity, the following documentations explaining safety performance of the system level or subsystem level of the vehicle to demonstrate that the REESS monitors and appropriately controls REESS operations at low temperatures at the safety boundary limits of the REESS:
- (a) A system diagram;
  - (b) Written explanation on the lower boundary temperature for safe operation of REESS;
  - (c) Method of detecting REESS temperature;
  - (d) Action taken when the REESS temperature is at or lower than the lower boundary for safe operation of the REESS.
- 6.12.** **Management of gases emitted from REESS**
- 6.12.1.** Under vehicle operation including the operation with a failure, the vehicle occupants shall not be exposed to any hazardous environment caused by emissions from REESS.
- 6.12.2.** Open-type traction batteries shall meet the requirements of paragraph 5.4. of this Regulation with regard to hydrogen emissions.
- 6.12.3.** For REESS other than open-type traction battery, the requirement of paragraph 6.12.1. is deemed to be satisfied, if all applicable requirements of the following tests are met: paragraph 6.2. (vibration), paragraph 6.3. (thermal shock and cycling), paragraph 6.6. (external short circuit protection), paragraph 6.7. (overcharge protection), paragraph 6.8. (over-discharge protection), paragraph 6.9. (over-temperature protection) and paragraph 6.10. (overcurrent protection).
- 6.13.** **Warning in the event of operational failure of vehicle controls that manage REESS safe operation.**
- The REESS or vehicle system shall provide a signal to activate the warning specified in paragraph 5.2.5. in the event of operational failure of the vehicle controls (e.g. input and output signals to the management system of REESS, sensors within REESS, etc.) that manage the safe operation of the REESS. REESS or vehicle manufacturer shall make available, at the request of the Technical Service with its necessity, the following documentation explaining safety performance of the system level or subsystem level of the vehicle:
- 6.13.1.** A system diagram that identifies all the vehicle controls that manage REESS operations. The diagram must identify what components are used to generate a warning due to operational failure of vehicle controls to conduct one or more basic operations.
  - 6.13.2.** A written explanation describing the basic operation of the vehicle controls that manage REESS operation. The explanation must identify the components of the vehicle control system, provide description of their functions and capability to manage the REESS, and provide a logic



diagram and description of conditions that would lead to triggering of the warning.

**6.14. Warning in the case of a thermal event within the REESS.**

The REESS or vehicle system shall provide a signal to activate the warning specified in paragraph 5.2.5. in the case of a thermal event in the REESS (as specified by the manufacturer). REESS or vehicle manufacturer shall make available, at the request of the Technical Service with its necessity, the following documentation explaining safety performance of the system level or subsystem level of the vehicle:

**6.14.1. The parameters and associated threshold levels that are used to indicate a thermal event (e.g. temperature, temperature rise rate, SOC level, voltage drop, electrical current, etc.) to trigger the warning.**

**6.14.2. A system diagram and written explanation describing the sensors and operation of the vehicle controls to manage the REESS in the event of a thermal event.**

**6.15. Thermal propagation**

For a REESS containing flammable electrolyte, the vehicle occupants shall not be exposed to any hazardous environment caused by thermal propagation which is triggered by an internal short circuit leading to a single cell thermal runaway. To ensure this, the requirements of paragraphs 6.15.1. and 6.15.2. shall be satisfied.<sup>5</sup>

This test applies for vehicles with a passenger compartment only.

**6.15.1. The REESS or vehicle system shall provide a signal to activate the advance warning indication in the vehicle to allow egress or 5 minutes prior to the presence of a hazardous situation inside the passenger compartment caused by thermal propagation which is triggered by an internal short circuit leading to a single cell thermal runaway such as fire, explosion or smoke. This requirement is deemed to be satisfied if the thermal propagation does not lead to a hazardous situation for the vehicle occupants. REESS or vehicle manufacturer shall make available, at the request of the Technical Service with its necessity, the following documentation explaining safety performance of the system level or subsystem level of the vehicle:**

**6.15.1.1. The parameters (for example, temperature, voltage or electrical current) which trigger the warning indication.**

**6.15.1.2. Description of the warning system.**

**6.15.2. The REESS or vehicle system shall have functions or characteristics in the cell or REESS intended to protect vehicle occupants (as described in paragraph 6.15.) in conditions caused by thermal propagation which is triggered by an internal short circuit leading to a single cell thermal runaway. REESS or vehicle manufacturers shall make available, at the request of the Technical Service with its necessity, the following documentation explaining safety performance of the system level or subsystem level of the vehicle:**

**6.15.2.1. A risk reduction analysis using appropriate industry standard methodology, which documents the risk to vehicle occupants caused by thermal propagation which is triggered by an internal short circuit leading to a single cell thermal runaway and documents the reduction of**

---

<sup>5</sup> The manufacturer will be accountable for the verity and integrity of documentation submitted, and assume full responsibility for the safety of occupants against adverse effects arising from thermal propagation caused by internal short circuit.

risk resulting from implementation of the identified risk mitigation functions or characteristics.

- 6.15.2.2. A system diagram of all relevant physical systems and components. Relevant systems and components are those which contribute to protection of vehicle occupants from hazardous effects caused by thermal propagation triggered by a single cell thermal runaway.
- 6.15.2.3. A diagram showing the functional operation of the relevant systems and components, identifying all risk mitigation functions or characteristics.
- 6.15.2.4. For each identified risk mitigation function or characteristic:
  - 6.15.2.4.1. A description of its operation strategy;
  - 6.15.2.4.2. Identification of the physical system or component which implements the function;
  - 6.15.2.4.3. One or more of the following engineering documents relevant to the manufacturers design which demonstrates the effectiveness of the risk mitigation function:
    - (a) Tests performed including procedure used and conditions and resulting data;
    - (b) Analysis or validated simulation methodology and resulting data."

*Paragraphs 7.1. to 7.1.2., amend to read:*

- 7.1. Every modification of the vehicle or REESS type with regard to this Regulation shall be notified to the Type Approval Authority which approved the vehicle or REESS type. The Authority may then either:
  - (a) Decide, in consultation with the manufacturer, that a new type approval is to be granted; or
  - (b) Apply the procedure contained in paragraph 7.1.1. (Revision) and, if applicable, the procedure contained in paragraph 7.1.2. (Extension).
- 7.1.1. **Revision**

When details recorded in the information documents of Annex 1 - Appendix 1 or Annex 1 - Appendix 2 have changed and the Type Approval Authority considers that the modifications made are unlikely to have appreciable adverse effect, and that in any case the vehicle still meets the requirements, the modification shall be designated a "revision".

In such a case, the Type Approval Authority shall issue the revised pages of the information documents of Annex 1 – Appendix 1 or Annex 1 – Appendix 2 as necessary, marking each revised page to show clearly the nature of the modification and the date of reissue. A consolidated, updated version of the information documents of Annex 1 – Appendix 1 or Annex 1 – Appendix 2, accompanied by a detailed description of the modification, shall be deemed to meet this requirement. ~~Consider that the modifications made are unlikely to have an appreciable adverse effect and that in any case the vehicle or the REESS still complies with the requirements, or~~
- 7.1.2. **Extension**

The modification shall be designated as an "extension" if, in addition to the change of the particulars recorded in the information folder:

  - (a) Further inspections or tests are required; or
  - (b) Any information on the communication document (with the exception of its attachments) has changed; or
  - (c) Approval to a later series of amendments is requested after its entry

~~into force. Require a further test report from the Technical Service responsible for conducting the tests."~~

*Paragraphs 7.2. to 7.3., shall be deleted.*

*Paragraph 8., amend to read:*

## **"8. Conformity of Production**

**The conformity of production procedure shall comply with the requirements set out in Schedule 1 of the Agreement (E/ECE/TRANS/505/Rev.3)."**

*Paragraphs 8.3. to 8.4.5., shall be deleted.*

*Paragraphs 9.1. to 9.2., amend to read:*

"9.1. The approval granted in respect of a vehicle/REESS type, pursuant to this Regulation may be withdrawn if the requirements laid down in paragraph 8. above are not complied with, ~~or if the vehicle/REESS or its components fail to pass the tests provided for in paragraph 8.3.5. above.~~

9.2. If a Contracting Party to the Agreement applying this Regulation withdraws an approval it has previously granted, it shall forthwith so notify the other Contracting Parties applying this Regulation, by means of **a copy of the approval form bearing at the end, in large letters, the signed and dated annotation "APPROVAL WITHDRAWN"**. ~~a communication form conforming to the Model in Annex 1 (Part 1 or Part 2) to this Regulation."~~

*Paragraph 10., amend to read:*

## **"10. Production Definitively Discontinued**

If the holder of the approval completely ceases to manufacture a vehicle/REESS type approved in accordance with this Regulation, he shall so inform the **Type Approval** Authority which granted the approval. Upon receiving the relevant communication, that **Type Approval** Authority shall inform thereof the other Contracting Parties to the ~~1958~~-Agreement applying this Regulation by means of **a copy of the approval form bearing at the end, in large letters, the signed and dated annotation "PRODUCTION DISCONTINUED"**. ~~a communication form conforming to the model in Annex 1 (Part 1 or Part 2) to this Regulation."~~

*Insert new paragraphs 12 to 12.7., to read:*

## **"12. Transitional provisions**

12.1. **As from the official date of entry into force of the 01 series of amendments, no Contracting Party applying this Regulation shall refuse to grant or refuse to accept type approvals under this Regulation as amended by the 01 series of amendments.**

12.2. **As from 1 September [2025], Contracting Parties applying this Regulation shall not be obliged to accept type approvals to the preceding series of amendments, first issued after 1 September [2025].**

12.3. **Until 1 September [2027], Contracting Parties applying this Regulation shall accept type approvals to the preceding series of amendments, first issued before 1 September [2025].**

- 12.4. **As from 1 September [2027], Contracting Parties applying this Regulation shall not be obliged to accept type approvals issued to the preceding series of amendments to this Regulation.**
- 12.5. **Contracting Parties applying this Regulation may grant type approvals according to any preceding series of amendments to this Regulation.**
- 12.6. **Contracting Parties applying this Regulation shall continue to grant extensions of existing approvals to any preceding series of amendments to this Regulation.**
- 12.7. **Notwithstanding the transitional provisions above, Contracting Parties whose application of this Regulation comes into force after the date of entry into force of the most recent series of amendments are not obliged to accept approvals which were granted in accordance with any of the preceding series of amendments to this Regulation."**

*Annex 1 – Part 2*, amend and insert new items 6.1. to 6.3., to read:

## "Annex 1 – Part 2

### Communication

...

of a REESS type as component/~~separate technical unit~~<sup>2</sup> pursuant to Regulation No. 136

...

6. Installation restrictions applicable to the REESS:.....

**6.1. Removable REESS: Yes / No <sup>2</sup>** .....

**6.2. Removable REESS that can be mounted in any orientation: Yes / No <sup>2</sup>**.....

**6.3. REESS intended only for vehicles without passenger compartment: Yes / No <sup>2</sup>**...

..."

*Annex 3, paragraphs 2. to 3.*, amend to read:

"2. Test conditions

The access probe ...

Internal **electrical protection** barriers are ...

A low-voltage ... inside the **electrical protection** barrier or enclosure.

...

3. Acceptance conditions

...

In ~~the~~ case of the test for **protection degree IPXXB**, the jointed ...

In case of the tests for **protection degree IPXXD**, the access probe ..."

*Annex 3, Figure 1*, shall be deleted.

Annex 3, insert new Figure 1 to read:

"Figure 1  
**Jointed Test Finger**

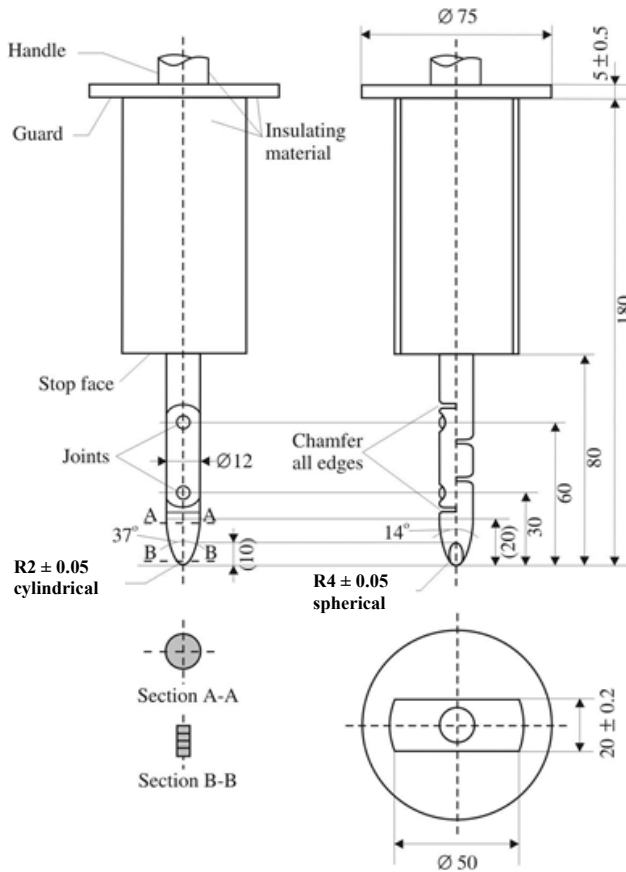

Material: metal, except where otherwise specified

Linear dimensions in millimeters

Tolerances on dimensions without specific tolerance:

- (a) On angles: 0/-10 seconds;
- (b) On linear dimensions: up to 25 mm: 0/ -0.05 mm over 25 mm:  $\pm 0.2$  mm
  - (i) up to 25 mm: 0/-0.05 mm.
  - (ii) over 25 mm:  $\pm 0.2$  mm.

Both joints shall permit movement in the same plane and the same direction through an angle of  $90^\circ$  with a 0 to  $+10^\circ$  tolerance."

Insert new Annex 4 (Verification of potential equalization), to read:

## "Annex 4

### Verification of Potential Equalization

1. Test method using a resistance tester.

The resistance tester is connected to the measuring points (typically, electrical chassis and electro conductive enclosure/electrical protection barrier) and the resistance is measured using a resistance tester that meets the specification that follows:

- (a) Resistance tester: Measurement current at least 0.2 A;
- (b) Resolution: 0.01  $\Omega$  or less;
- (c) The resistance R shall be less than 0.1  $\Omega$ .

2. Test method using DC power supply, voltmeter and ammeter.

Example of the test method using DC power supply, voltmeter and ammeter is shown below.

Figure 1

Example of Test Method using DC Power Supply

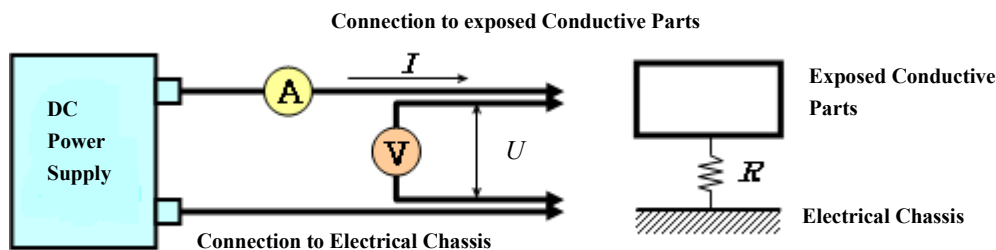

2.1. Test Procedure.

The DC power supply, voltmeter and ammeter are connected to the measuring points (Typically, electrical chassis and electro conductive enclosure/electrical protection barrier).

The voltage of the DC power supply is adjusted so that the current flow becomes at least 0.2 A.

The current "I" and the voltage "U" are measured.

The resistance "R" is calculated according to the following formula:

$$R = U / I$$

The resistance R shall be less than 0.1  $\Omega$ .

*Note: If lead wires are used for voltage and current measurement, each lead wire shall be independently connected to the electrical protection barrier/enclosure/electrical chassis. Terminal can be common for voltage measurement and current measurement.*

Annex 4A and Annex 4B (former), renumber as Annex 5A and Annex 5B.

Throughout new Annex 5A and Annex 5B (including Figures), replace the symbols for voltage, V, V<sub>b</sub>, V<sub>1</sub>, V<sub>1</sub>', V<sub>2</sub>, V<sub>2</sub>', with U, U<sub>b</sub>, U<sub>1</sub>, U<sub>1</sub>', U<sub>2</sub>, U<sub>2</sub>'.

Annex 5A, paragraphs 2. to 2.1., amend to read:

"2. Measurement method

The isolation resistance measurement shall be conducted by selecting an appropriate measurement method from among those listed in paragraphs 2.1. through 2.2. of this annex, depending on the electrical charge of the live parts or the isolation resistance, etc.

**Megohmmeter or oscilloscope measurements are appropriate alternatives to the procedure described below for measuring isolation resistance. In this case, it may be necessary to deactivate the on-board isolation resistance monitoring system.**

The range of the electrical circuit to be measured shall be clarified in advance, using electrical circuit diagrams, etc. **If the high voltage buses are conductively isolated from each other, isolation resistance shall be measured for each electrical circuit.**

...

In cases where the measured values are not stable due to the operation of the on-board isolation resistance monitoring system, ~~etc.~~, necessary modification for conducting the measurement may be carried out ~~by, such as~~ stopping the operation of the device concerned or removing it. Furthermore, when the device is removed, **a set of drawings will be used to prove that it shall be proven, using drawings, etc., that it will not change** the isolation resistance between the live parts and the electrical chassis **remains unchanged.**

**These modifications shall not influence the test results.**

Utmost care shall be exercised as to short circuit **and**, electric shock, ~~etc.~~, ~~for~~ since this confirmation might require direct operations of the high-voltage circuit.

2.1. Measurement method using DC voltage from ~~external~~ ~~off-vehicle~~ sources"

*Annex 5A, paragraph 2.1.2., amend to read:*

"2.1.2. Measurement method

An ~~insulator~~ **isolation** resistance test instrument shall ... "

*Annex 5A, paragraph 2.2.3.4., amend to read:*

"2.2.3.4. Fourth step

If  $V_1 U_1$  is greater than or equal to  $V_2 U_2$ , insert a standard known resistance ( $R_o$ ) between the negative side of the high voltage bus and the electrical chassis. With  $R_o$  installed, measure the voltage ( $V_1' U_1'$ ) between the negative side of the high voltage bus and the electrical chassis (see Figure 2).

Calculate the electrical isolation ( $R_i$ ) according to the following formula:

$$R_i = R_o * (V_b / V_1' - V_b / V_1) \text{ or } R_i = R_o * V_b U_b * (1 / V_1' U_1' - 1 / V_1 U_1)$$

...

If  $V_2 U_2$  is greater than  $V_1 U_1$ , insert a standard known resistance ( $R_o$ ) between the positive side of the high voltage bus and the electrical chassis. With  $R_o$  installed, measure the voltage ( $V_2' U_2'$ ) between the positive side of the high voltage bus and the electrical chassis (see Figure 3). ~~Calculate the electrical isolation ( $R_i$ ) according to the formula shown. Divide this electrical isolation value (in  $\Omega$ ) by the nominal operating voltage of the high voltage bus (in volts).~~

Calculate the electrical isolation ( $R_i$ ) according to the following formula:

$$R_i = R_o * (V_b / V_2' - V_b / V_2) \text{ or } R_i = R_o * V_b U_b * (1 / V_2' U_2' - 1 / V_2 U_2)$$

..."

*Annex 5A, paragraph 2.2.3.5., amend to read:*

"2.2.3.5. Fifth step

The electrical isolation ...high voltage bus (in ~~Vvolts~~) results ....

*Note:* The standard ... plus/minus 20 per cent (in ~~Vvolts~~). Ro is ... "

*Annex 5B, paragraphs 1. to 1.1., amend to read:*

"1. Measurement method

The isolation resistance measurement shall be conducted by selecting an appropriate measurement method from among those listed in paragraphs 1.1. through 1.2. of this ~~a~~Annex, depending on the electrical charge of the live parts or the isolation resistance, etc.

**Megohmmeter or oscilloscope measurements are appropriate alternatives to the procedure described below for measuring isolation resistance. In this case, it may be necessary to deactivate the on-board isolation resistance monitoring system.**

**The range of the electrical circuit to be measured shall be clarified in advance, using electrical circuit diagrams, etc. If the high voltage buses are galvanically isolated from each other, isolation resistance shall be measured for each electrical circuit.**

If the operating voltage of the ~~tested device~~ **Tested-Device** ( $V_b U_b$ , Figure 1) cannot be measured (e.g. due to disconnection of the electric circuit caused by main contactors or fuse operation) the test may be performed with a modified test device to allow measurement of the internal voltages (upstream the main contactors).

~~These modifications shall not influence the test results.~~

~~The range of the electrical circuit to be measured shall be clarified in advance, using electrical circuit diagrams, etc. If the high voltage buses are galvanically isolated from each other, isolation resistance shall be measured for each electrical circuit.~~ Moreover, modification necessary for measuring the isolation resistance may be carried out, such as removal of the cover in order to reach the live parts, drawing of measurement lines, change in software, etc.

In cases where the measured values are not stable due to the operation of the isolation resistance monitoring system, ~~etc.~~, necessary modification for conducting the measurement may be carried out ~~by, such as~~ stopping the operation of the device concerned or removing it. Furthermore, when the device is removed, **a set of drawings will be used to prove that it shall be proven, using drawings, etc., that it will not change** the isolation resistance between the live parts and the ground connection designated by the manufacturer as a point to be connected to the electrical chassis when installed on the vehicle **remains unchanged**.

**These modifications shall not influence the test results.**

Utmost care shall be exercised as to short circuit **and** electric shock, ~~etc., for~~ **since** this confirmation might require direct operations of the high-voltage circuit.

1.1. Measurement method using **DC** voltage from external sources"

*Annex 5B, paragraph 1.1.2., amend to read:*

"1.1.2. Measurement method

An ~~insulator~~ **isolation** resistance test instrument shall ... "

*Annex 5B, paragraph 1.2.3.4., amend to read:*

"1.2.3.4. Fourth step



If  $V_1 - U_1$  is greater than or equal to  $V_2 U_2$ , insert a standard known resistance ( $R_o$ ) between the negative pole of the ~~tested device~~ **Tested-Device** and the ground connection. With  $R_o$  installed, measure the voltage ( $V_1 - U_1'$ ) between the negative pole of the ~~tested device~~ **Tested-Device** and the ground connection (see Figure 2).

Calculate the electrical isolation ( $R_i$ ) according to the following formula:

$$R_i = R_o * (V_b / V_1' - V_b / V_1) \text{ or } R_i = R_o * V_b U_b * (1 / V_1' - U_1' - 1 / V_1 U_1)$$

...

If  $V_2 - U_2$  is greater than  $V_1 U_1$ , insert a standard known resistance ( $R_o$ ) between the positive pole of the ~~tested device~~ **Tested-Device** and the ground connection. With  $R_o$  installed, measure the voltage ( $V_2 - U_2'$ ) between the positive pole of the ~~tested device~~ **Tested-Device** and the ground connection (see Figure 3).

Calculate the electrical isolation ( $R_i$ ) according to the following formula:

$$R_i = R_o * (V_b / V_2' - V_b / V_2) \text{ or } R_i = R_o * V_b U_b * (1 / V_2' - U_2' - 1 / V_2 U_2)$$

..."

*Annex 5B, paragraph 1.2.3.5., amend to read:*

"1.2.3.5. Fifth step

The electrical isolation ...the ~~tested device~~ **Tested-Device** (in **Vvolts**) results  
....

*Note:* The standard ... ~~tested device~~ **Tested-Device** plus/minus 20 per cent (in **Vvolts**).  $R_o$  is ... "

*Annex 5 (former)*, renumber as Annex 6 and amend to read:

## "Annex 65

### Confirmation Method for the Function of an On-board Isolation Resistance Monitoring System

The on-board isolation resistance monitoring system shall be tested using the following procedure:

- (a) Determine the isolation resistance,  $R_i$ , of the electric power train with the electrical isolation monitoring system using the procedure outlined Annex 5A.
- (b) If the minimum isolation resistance value required in accordance with paragraphs 5.1.3.1. or 5.1.3.2. is  $100 \Omega/V$ , insert a resistor with resistance  $R_o$  between either side of the high voltage bus that exhibit lower value in  $U_1$  or  $U_2$  measured in accordance with paragraph 2.2.3. of Annex 5A and the electrical chassis. The magnitude of the resistor,  $R_o$ , shall be such that:

$$1/(1/(95xU) - 1/R_i) \leq R_o < 1/(1/(100xU) - 1/R_i)$$

where  $U$  is the working voltage of the electric power train.

- (c) If the minimum isolation resistance value required in accordance with paragraphs 5.1.3.1. or 5.1.3.2. is  $500 \Omega/V$ , insert a resistor with resistance  $R_o$  between either side of the high voltage bus that exhibit lower value in  $U_1$  or  $U_2$  measured in accordance with paragraph 2.2.3. of Annex 5A and the electrical chassis. The magnitude of the resistor,  $R_o$ , shall be such that:

$$1/(1/(475xU) - 1/R_i) \leq R_o < 1/(1/(500xU) - 1/R_i)$$

where  $U$  is the working voltage of the electric power train.

~~The function of the on-board isolation resistance monitoring system shall be confirmed by the following method:~~

~~Insert a resistor that does not cause the isolation resistance between the terminal being monitored and the electrical chassis to drop below the minimum required isolation resistance value. The warning shall be activated."~~

*Annex 6 - Part 1 (former)*, renumber as Annex 1 – Appendix 1.

*Annex 6 - Part 2 (former)*, renumber as Annex 1 – Appendix 2.

*Annex 1 – Appendix 2*, insert new item 1.1.1., to read:

"1.1.1. Type of REESS"

*Annex 6 - Part 3 (former)*, shall be deleted

*Insert new Annex 7A and Annex 7B, to read:*

## **"Annex 7A**

### **Verification Method for testing authorities confirming document based isolation resistance compliance of electrical design of the vehicle after water exposure**

This Annex describes the applicable requirements when certifying the manufacturer's high voltage equipment or system components against adverse water effects rather than a physical test. As a general rule, the electrical design or components of the vehicles shall comply with the requirements as specified in paragraphs "5.1.1. Protection against direct contact", "5.1.2. Protection against indirect contact", and "5.1.3. Isolation resistance" respectively and this will be separately verified by the testing authority. Vehicle manufacturers shall provide information to testing authorities to identify, as a point of reference, the mounting location for each high-voltage component in/on the vehicle.

1. Documentation shall contain the following information:
  - (a) on how the manufacturer tested isolation resistance compliance of electrical design of the vehicle by using fresh water;
  - (b) on how, after the test had been carried out, the high-voltage component or system was inspected for ingress of water and how, depending on its mounting location, each high voltage component/system met the appropriate degree of protection against water.
2. The testing authority will verify and confirm the authenticity of documented conditions that have been observed, and should have been complied with, during the process of certification by manufacturer:
  - 2.1. It is permitted that, during the test, the moisture contained inside the enclosure is partly condensed. The dew which may be deposited is not considered as ingress of water. For the purpose of the tests, the surface area of the tested high-voltage component or system is calculated with an accuracy of 10 per cent. If possible, the tested high-voltage component or system is run energized. If the tested high-voltage component or system is energized, adequate safety precautions are taken.
  - 2.2. For electrical components, externally attached (e.g. in engine compartment), open underneath, both exposed or protected locations, the testing authority shall verify, with a view to confirming the compliance, whether the test is conducted by spraying the high-voltage component or system from all practicable directions with a stream of water from a standard test nozzle as shown in Figure 1. The following parameters are observed during the test in particular:
    - (a) Nozzle internal diameter: 6.3 mm;
    - (b) Delivery rate: 11.9 – 13.2 l/min;
    - (c) Water pressure at the nozzle: approximately 30 kPa (0.3 bar);
    - (d) Test duration per m<sup>2</sup> of surface area of the tested high-voltage component or system: 1 min;
    - (e) Minimum test duration: 3 min;
    - (f) Distance from nozzle to tested high-voltage component or system surface: approximately 3 m (this distance may be reduced, if necessary to ensure proper wetting when spraying upwards).

**Figure 1**  
**Standard Nozzle for the Test**

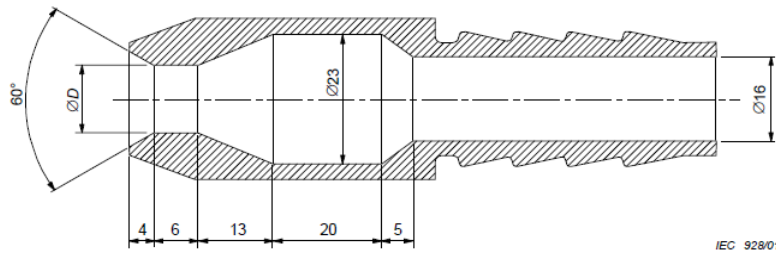

Dimensions in millimetres

$D$  is 6.3 mm as specified in (a) above.

- 2.3. For electrical components, externally attached (e.g. in engine compartment), covered from underneath, the testing authority shall verify, with a view to confirming the compliance, whether:
- The cover protects the component against direct spray water from underneath and is not visible;
  - The test is conducted by using splashing test nozzle as shown in Figure 2;
  - The moving shield is removed from the spray nozzle and the machine is sprayed from all practicable directions;
  - The water pressure is adjusted to give a delivery rate of  $(10 \pm 0.5)$  l/min (pressure approximately 80 kPa to 100 kPa (0.8 bar to 1.0 bar));
  - The test duration is  $1 \text{ min/m}^2$  of calculated surface area of the machine (excluding any mounting surface and cooling fin) with a minimum duration of 5 min.

**Figure 2**  
**Splashing Test Nozzle**

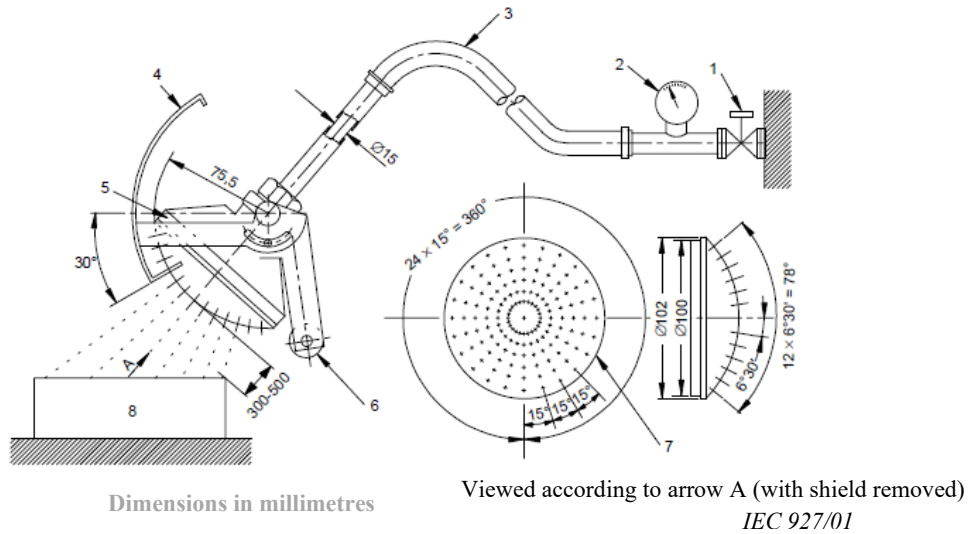

**Note:**

- |   |   |
|---|---|
| <p>1. Cock<br/>2. Pressure gauge<br/>3. Hose<br/>4. Moving shield – aluminium<br/>5. Spray nozzle<br/>6. Counter weight</p> | <p>7. Spray nozzle – brass with 121 holes <math>\varnothing</math> 0,5:<br/>1. hole in centre<br/>2. inner circle of 12 holes at 30° pitch<br/>4. outer circle of 24 holes at 15° pitch<br/>8. Machine under test</p> |
|---|---|

3. The entire high voltage system or each component is checked to comply with the isolation resistance requirement in paragraph 5.1.3. with the following conditions:
- (a) The electric chassis shall be simulated by an electric conductor, e.g. a metal plate, and the components are attached with their standard mounting devices to it;
  - (b) Cables, where provided, shall be connected to the component.
4. The parts designed not to be wet during operation are not allowed to be wet and no accumulation of water which could have reached them is tolerated inside the high-voltage component or system.

## Annex 7B

### Vehicle-based Test Procedure for Protection against Water Effects

#### 1. Washing

This test is intended to simulate the normal washing of vehicles, but not specific cleaning using high water pressure or underbody washing.

The areas of the vehicle regarding this test are border lines, i.e. a seal of two parts such as flaps, glass seals, outline of opening parts, outline of front grille and seals of lamps.

All border lines shall be exposed and followed in all directions with the water stream using a hose nozzle and conditions in accordance with IPX5 as specified in Annex 7A.

#### 2. Driving through standing water

The vehicle shall be driven in a wade pool, with 10 cm water depth, over a distance of 500 m at a speed of 20 km/h, in a time of approximately 1.5 min. If the wade pool used is less than 500 m in length, then the vehicle shall be driven through it several times. The total time, including the periods outside the wade pool, shall be less than 10 min. "

*Annex 7, including its appendixes (former), renumber as Annex 8.*

*Annex 8, paragraph 2., amend to read:*

#### "2. Description of test

The hydrogen emission test (Figure 17.1 of ~~the present Annex 8~~) is ... "

*Annex 8, paragraph 3.2.1., amend to read:*

#### "3.2.1. The REESS shall be in good mechanical condition and have been subject to minimum of 5 standard cycles (as specified in Annex 98, Appendix 1)."

*Annex 7, Figure 7.1, (former), renumber as Annex 8, Figure 1.*

*Annex 8, paragraph 4.2., amend to read:*

#### "4.2. Hydrogen emission measurement enclosure

The hydrogen emission measurement enclosure shall be a gas-tight measuring chamber able to contain ... in accordance with **Annex 8**, Appendix 1 ~~to this annex~~. The inner surface ...

To accommodate ... as specified in **Annex 8**, Appendix 1 ~~to this annex~~.

...

The enclosure shall ... (see Annex 87, Appendix 1, paragraph 2.1.1.), taking ... "

*Annex 8, paragraph 4.7.2., amend to read:*

#### "4.7.2. Calibration ...specified in **Annex 8**, Appendix 1 may ..."

*Annex 8, paragraph 5.1.1.1., amend to read:*

#### "5.1.1.1. Discharges and initial charges of the REESS

The procedure starts ... at a steady speed of 70 ~~per cent~~  $\pm$  5 per cent of the maximum ..."

*Annex 8, paragraph 5.1.1.2., amend to read:*

"5.1.1.2. Initial charge of the REESS

The charge is carried out:

- (a) With the charger;
  - (b) In an ambient temperature between 293 K and 303 K.
- ..."

*Annex 8, paragraphs 5.1.2. to 5.1.3., amend to read:*

"5.1.2. Discharge of the REESS

The REESS is discharged ... at a steady speed of 70 per cent ± 5 per cent from the maximum ...

5.1.3. Soak

Within fifteen ... in paragraph 5.1.2., the vehicle ... shall be soaked at 293 K ± 2 K."

*Annex 8, paragraph 5.1.4.6., amend to read:*

"5.1.4.6. The start of ... calculation (**Annex 8**, paragraph 6. ~~of this annex~~). The ambient ..."

*Annex 8, paragraph 5.1.4.9., amend to read:*

"5.1.4.9. The end of ... sampling, as specified in **Annex 8**, paragraph 5.1.4.6. ~~of this annex~~. The different ... the calculation in **Annex 8**, paragraph 6. ~~of this annex~~."

*Annex 8, paragraphs 5.1.5.1. to 5.1.5.2., amend to read:*

"5.1.5.1. Within seven days ... according to **Annex 8**, paragraph 5.1.2. ~~of this annex~~.

5.1.5.2. The steps of the procedure in **Annex 8**, paragraph 5.1.3. ~~of this annex~~ shall be repeated."

*Annex 8, paragraph 5.1.5.8., amend to read:*

"5.1.5.8. The start of ... calculation (**Annex 8**, paragraph 6. ~~of this annex~~) The ambient ..."

*Annex 8, paragraph 5.1.5.11., amend to read:*

"5.1.5.11. The end of ... calculation in **Annex 8**, paragraph 6. ~~of this annex~~.

*Annex 8, paragraphs 5.2.1. to 5.2.3., amend to read:*

"5.2.1. REESS preparation

The ageing of REESS ... cycles (as specified in Annex ~~89~~, Appendix 1).

5.2.2. Discharge of the REESS

The REESS is discharged at 70 per cent ± 5 per cent of ...

5.2.3. Soak

Within 15 minutes of ... soaked at 293 K ± 2 K for a minimum ..."

*Annex 8, paragraph 5.2.4.6., amend to read:*

"5.2.4.6. The start of ... calculation (**Annex 8**, paragraph 6. ~~of this annex~~) The ambient enclosure ..."

*Annex 8, paragraph 5.2.4.9., amend to read:*

"5.2.4.9. The end of ... calculation in **Annex 8**, paragraph 6. ~~of this annex~~"

*Annex 8, paragraph 5.2.5.8., amend to read:*

"5.2.5.8. The start of ... calculation (~~Annex 8, paragraph 6. of this annex~~) The ambient ..."

*Annex 8, Appendix 1, paragraph 2.1.3., amend to read:*

"2.1.3. The chamber shall be checked as in **Annex 8, Appendix 1**, paragraph 2.3. ~~of this annex.~~ If ..."

*Annex 8, Appendix 1, paragraph 2.2.1., amend to read:*

"2.2.1. Variable-volume enclosure ... maintained at 293 K  $\pm$  2 K, throughout ..."

*Annex 8, Appendix 1, paragraph 2.2.8., amend to read:*

"2.2.8. The change in mass ... with **Annex 8, Appendix 1**, paragraph 2.4. ~~of this annex~~ and shall not exceed 0.5 g. "

*Annex 8, Appendix 1, paragraph 2.3.4., amend to read:*

"2.3.4. When the enclosure temperature stabilizes at 293 K  $\pm$  2 K, the enclosure ..."

*Annex 8, Appendix 1, paragraph 3., amend to read:*

"3. Calibration of the hydrogen analyser

The analyser should ... See **Annex 8**, paragraph 4. ~~7.2. of Annex 7.~~

Each of ..."

*Annex 8, including its appendix (former), renumber as Annex 9.*

*Annex 9 – Appendix 1, amend to read:*

## "~~Annex 98~~ – Appendix 1

### Procedure for Conducting a Standard Cycle

A standard cycle ~~will~~ **shall** start with a standard discharge followed by a standard charge. **The standard cycle shall be conducted at an ambient temperature of 20  $\pm$  10 °C.**

Standard discharge:

Discharge rate: The discharge procedure including termination criteria shall be defined by the manufacturer. If not specified, then it shall be a discharge with 1C current **for a complete REESS and REESS subsystems.**

Discharge limit (end voltage): Specified by the manufacturer

**For a complete vehicle, discharge procedure using a dynamometer shall be defined by the manufacturer. Discharge termination will be according to vehicle controls.**

Rest period after discharge: Minimum ~~30~~ **15** min

Standard charge:

The charge procedure ~~including termination criteria~~ shall be defined by the manufacturer. If not specified, then it shall be a charge with C/3 current. **Charging is continued until normally terminated. Charge termination shall be according to paragraph 2. of Annex 9, Appendix 2 for REESS or REESS subsystem.**

**For a complete vehicle that can be charged by an external source, charge procedure using an external electric power supply shall be defined by the manufacturer. For a complete vehicle that can be charged by on-board energy sources, a charge procedure using a dynamometer shall be defined by the manufacturer. Charge termination will be according to vehicle controls."**



*Insert new Annex 9 – Appendix 2, to read:*

## **"Annex 9 – Appendix 2**

### **Procedure for SOC Adjustment**

1. **The adjustment of SOC shall be conducted at an ambient temperature of  $20 \pm 10$  °C for vehicle-based tests and  $22 \pm 5$  °C for component-based tests.**
2. **The SOC of the Tested-Device shall be adjusted according to one of the following procedures as applicable. Where different charging procedures are possible, the REESS shall be charged using the procedure which yields the highest SOC:**
  - (a) **For a vehicle with a REESS designed to be externally charged, the REESS shall be charged to the highest SOC in accordance with the procedure specified by the manufacturer for normal operation until the charging process is normally terminated;**
  - (b) **For a vehicle with a REESS designed to be charged only by an energy source on the vehicle, the REESS shall be charged to the highest SOC which is achievable with normal operation of the vehicle. The manufacturer shall advise on the vehicle operation mode to achieve this SOC;**
  - (c) **In case that the REESS or REESS subsystem is used as the Tested-Device, the Tested-Device shall be charged to the highest SOC in accordance with the procedure specified by the manufacturer for normal use operation until the charging process is normally terminated. Procedures specified by the manufacturer for manufacturing, service or maintenance may be considered as appropriate if they achieve an equivalent SOC as for that under normal operating conditions. In case the Tested-Device does not control SOC by itself, the SOC shall be charged to not less than 95 per cent of the maximum normal operating SOC defined by the manufacturer for the specific configuration of the Tested-Device.**
3. **When the vehicle or REESS subsystem is tested, the SOC shall be no less than 95 per cent of the SOC according to paragraphs 1. and 2. above for REESS designed to be externally charged and shall be no less than 90 per cent of SOC according to paragraphs 1. and 2. above for REESS designed to be charged only by an energy source on the vehicle. The SOC will be confirmed by a method provided by the manufacturer."**

*Annex 8A (former), renumber as Annex 9A.*

*Annex 9A, paragraphs 2.1. to 2.2., amend to read:*

- "2.1. This test shall be conducted either with the complete REESS or with ~~related~~ REESS subsystem(s) ~~including the cells and their electrical connections~~. If the manufacturer chooses to test with ~~related~~ REESS subsystem(s), the manufacturer shall demonstrate that the test result can reasonably represent the performance of the complete REESS with respect to its safety performance under the same conditions. If the electronic management unit for the REESS is not integrated in the casing enclosing the cells, then the electronic management unit may be omitted from installation on the ~~tested device~~ **Tested-Device** if so requested by the manufacturer.

- 2.2. The ~~tested device~~ **Tested-Device** shall be firmly secured to the platform of the vibration machine in such a manner as to ensure that the vibrations are directly transmitted to the ~~tested device~~ **Tested-Device**.

**The Tested-Device should be mounted with its original mounting points, if those exist in the Tested-Device, as mounted in the vehicle."**

*Annex 9A, paragraphs 3.1. to 3.2., amend to read:*

- "3.1. General test conditions

The following conditions shall apply to the ~~tested device~~ **Tested-Device**:

- (a) The test shall be conducted at an ambient temperature of ~~22±5~~ **22±5** °C;
- (b) At the beginning of the test, the SOC shall be adjusted **in accordance with Annex 9, Appendix 2** ~~to a value in the upper 50 per cent of the normal operating SOC range of the tested device~~;
- (c) At the beginning ...

- 3.2. Test procedures

The ~~tested devices~~ **Tested-Device** shall be ...

This cycle shall be repeated 12 times for a total of 3 hours in the vertical direction of the mounting orientation of the REESS as specified by the manufacturer.

**At the request of the manufacturer, the test may be performed using the cycle repeated 12 times for a total of 3 hours in each of the three mutually perpendicular mounting orientations of the Tested-Device.**

...

At the request of ... limited to ~~the installation approvals~~ for a specific vehicle type.

After the vibration, a standard cycle as described in Annex ~~8~~ **9**, Appendix 1 shall be conducted, ..."

*Annex 8B (former), renumber as Annex 9B.*

*Annex 9B, paragraph 2., amend to read:*

- "2. Installations

This test shall be conducted either with the complete REESS or with ~~related REESS subsystem(s) of the REESS including the cells and their electrical connections~~ **related** subsystem(s), the manufacturer shall ..."

*Annex 9B, paragraphs 3.1. to 3.2., amend to read:*

- "3.1. General test conditions

The following conditions shall apply to the ~~tested device~~ **Tested-Device** at the start of the test:

- (a) The SOC shall be adjusted **in accordance with Annex 9, Appendix 2** ~~to a value in the upper 50 per cent of the normal operating SOC range~~;
- (b) All protection devices, which would affect the function of the ~~tested device~~ **Tested-Device** and which are relevant to the outcome of the test shall be operational.

- 3.2. Test procedure

The ~~tested device~~ **Tested-Device** shall be ...at an ambient temperature of ~~20~~ **22 ± 0.5** °C.

After the storage ...in Annex ~~89~~, Appendix 1 shall be conducted, if not inhibited by the ~~tested device~~ **Tested-Device**.

The test shall end with an observation period of 1 hour at the ambient temperature conditions of the test environment."

*Annex 8C (former)*, renumber as Annex 9C.

*Annex 9C, paragraph 2.1.*, amend to read:

"2.1. General test conditions

The following conditions shall apply to the removed REESS at the start of the test:

- (a) Adjust the SOC to at least 90 per cent of the rated capacity as specified in the ~~Annex 6, Part 1, Annex 1, Appendix 1~~, paragraph 3.4.3. ~~or Annex 6, Part 2, Annex 1, Appendix 2~~, paragraph 1.4.3. ~~or Annex 6, Part 3, paragraph 2.3.2.~~
- (b) The test shall be performed at  $20^{\circ}\text{C} \pm 10^{\circ}\text{C}$ ."

*Annex 9C, paragraph 2.2.*, amend to read:

"2.2. Test procedure

...

Directly after the termination of the drop test a standard cycle as described in Annex ~~89~~, Appendix 1 shall be conducted, if not inhibited.

The test shall end with an observation period of 1 hour at the ambient temperature conditions of the test environment."

*Annex 8D (former)*, renumber as Annex 9D.

*Annex 9D, paragraphs 2.1. to 2.2.*, amend to read:

"2.1. This test shall be conducted either with the complete REESS or with ~~related~~ REESS subsystem(s) ~~including the cells and their electrical connections~~. If the manufacturer chooses to test with ~~related~~ REESS subsystem(s), the manufacturer shall ...

2.2. The Tested-Device shall be connected to the test fixture ~~only~~ by the intended mountings provided for the purpose of attaching the REESS or REESS subsystem to the vehicle.

**At the manufacturer discretion, removable REESS that may be mounted in any orientation on the vehicle may be tested without intended mountings."**

*Annex 9D, paragraphs 3.1. to 3.2.*, amend to read:

"3.1. General test conditions

The following condition and requirements shall apply to the test:

- (a) The test shall be conducted at an ambient temperature of  $20 \pm 10^{\circ}\text{C}$ ;
- (b) At the beginning of the test, the SOC shall be adjusted **in accordance with Annex 9, Appendix 2** ~~to a value in the upper 50 per cent of the normal operating SOC range~~;
- (c) At the beginning of the test, all protection devices which effect the function of the ~~tested device~~ **Tested-Device** and which are relevant to the outcome of the test, shall be operational.

3.2. Test procedure

...

Directly after the termination of the mechanical shock test a standard cycle as described in Annex 89, Appendix 1 shall be conducted, if not inhibited.

The test shall end with an observation period of 1 hour at the ambient temperature conditions of the test environment."

*Annex 8E, including its Appendix (former), renumber as Annex 9E.*

*Annex 9E, paragraph 2.1., amend to read:*

"2.1. Installations

This test shall be conducted either with the complete REESS or with ~~related~~ REESS subsystem(s) ~~including the cells and their electrical connections~~. If the manufacturer chooses to test with ~~related~~ REESS subsystem(s), the manufacturer shall ..."

*Annex 9E, paragraph 3.1., amend to read:*

"3.1. General test conditions

The following requirements and conditions shall apply to the test:

- (a) The test shall be conducted at a temperature of at least 0 °C;
- (b) At the beginning of the test, the SOC shall be adjusted **in accordance with Annex 9, Appendix 2** ~~to a value in the upper 50 per cent of the normal operating SOC range;~~
- (c) At the beginning of the test, all protection devices which ~~effect~~ **affect** the function of the ~~tested device~~ **Tested-Device** and are relevant for the outcome of the test shall be operational."

*Annex 9E, paragraph 3.2.2., amend to read:*

"3.2.2. Component based test

**In case of component based test, the manufacturer may choose either gasoline pool fire test or LPG burner test.**

The ~~tested device~~ **Tested-Device** shall be ..."

*Annex 9E, paragraph 3.3., amend to read:*

"3.3. **Gasoline pool fire test set up for both vehicle-based and component-based test.**

The flame to which ..."

*Annex 9E, paragraph 3.4., renumber as paragraph 3.3.1.*

*Annex 9E, paragraph 3.5., renumber as paragraph 3.3.2., and amend to read:*

"3.3.2.5. During phase C ..., as prescribed in Annex ~~8E-9E~~ - Appendix 1. There shall be ..."

*Annex 9E, paragraphs 3.6. to 3.7., renumber as paragraphs 3.3.3. to 3.3.4.*

*Annex 9E, paragraphs 3.7.1 to 3.7.2., renumber as paragraphs 3.3.4.1. to 3.3.4.2.*

*Annex 9E, paragraph 3.7.3., renumber as paragraph 3.3.4.3. and amend to read:*

"3.3.4.3. Phase C: Indirect exposure to flame (Figure 3)

As soon as ... 60 seconds.

~~However this shall only be permitted where it is demonstrable to the satisfaction of the Technical Service that it will not result in a reduction in the severity of the test."~~

*Annex 9E, paragraph 3.7.4., renumber as paragraph 3.3.4.4.*

*Annex 9E, insert new paragraphs 3.4. to 3.4.7., to read:*

- "3.4. LPG burner fire test set up for component based test**
- 3.4.1. The Tested-Device shall be placed on a test equipment, in the position that the manufacturer's design intends.**
- 3.4.2. LPG burner shall be used to produce flame to which the Tested-Device is exposed. The height of the flame shall be about 60 cm or more, without the Tested-Device.**
- 3.4.3. The flame temperature shall be measured continuously by temperature sensors. An average temperature shall be calculated, at least every second for the duration of the whole fire exposure, as the arithmetic average of temperatures measured by all temperature sensors fulfilling the location requirements described in paragraph 3.4.4.**
- 3.4.4. All temperature sensors shall be installed at a height of  $5 \pm 1$  cm below the lowest point of the Tested-Device's external surface when oriented as described in paragraph 3.4.1. At least one temperature sensor shall be located at the centre of Tested-Device, and at least four temperature sensors shall be located within 10 cm from the edge of the Tested-Device towards its centre with nearly equal distance between the sensors.**
- 3.4.5. The bottom of Tested-Device shall be exposed to the even flame directly and entirely by fuel combustion. LPG burner flame shall exceed the horizontal projection of the Tested-Device by at least 20 cm.**
- 3.4.6. An average temperature of 800 °C shall be reached within 30 seconds and maintained between 800°C and 1,100°C The Tested-Device shall then be exposed to the flame for 2 minutes.**
- 3.4.7. After direct exposure to flame the Tested-Device shall be observed until such time as the surface temperature of the Tested-Device has decreased to ambient temperature or has been decreasing for a minimum of 3 hours."**

*Annex 8F (former), renumber as Annex 9F.*

*Annex 9F, paragraphs 1. to 3.3., amend to read:*

- "1. Purpose**
- The purpose of this test is to verify the performance of the short circuit protection. ~~This functionality, if implemented, shall interrupt or limit the short circuit current~~ to prevent the REESS from any further related severe events caused by short circuit current.
- 2. Installations**
- This test shall be conducted either **with a complete vehicle or** with the complete REESS or with ~~the related~~ REESS subsystem(s), ~~including the cells and their electrical connections~~. If the manufacturer chooses to test with ~~REESS-related~~ subsystem(s), **the Tested-Device shall be able to deliver the nominal voltage of the complete REESS and** the manufacturer shall demonstrate that the test result can reasonably represent the performance of the complete REESS with respect to its safety performance under the same conditions. If the electronic management unit for the REESS is not integrated in the casing enclosing the cells, then the electronic management unit may be omitted from installation on the ~~tested device~~ **Tested-Device** if so requested by the manufacturer.
- For a test with a complete vehicle, the manufacturer may provide information to connect a breakout harness to a location just outside the REESS that would permit applying a short circuit to the REESS.**
- 3. Procedures**
- 3.1. General test conditions**

The following condition shall apply to the test:

- (a) The test shall be conducted at a ambient temperature of  $20 \pm 10$  °C or at higher temperature if requested by the manufacturer;
- (b) At the beginning of the test, the SOC shall be adjusted **in accordance with Annex 9, Appendix 2** ~~to a value in the upper 50 per cent of the normal operating SOC range;~~
- (c) At the beginning of the test, all protection devices which would affect the function of the ~~tested device~~ **Tested-Device** and which are relevant to the outcome of the test shall be operational.
- (d) **For testing with a complete vehicle, a breakout harness is connected to the manufacturer specified location and vehicle protection systems relevant to the outcome of the test shall be operational.**

3.2. Short circuit

At the start ... be conducted.

**For testing with a complete REESS or REESS subsystem(s),** ~~the positive and negative terminals of the tested device~~ **Tested-Device** shall be connected to each other to produce a short circuit. The connection ... 5 mΩ.

**For testing with a complete vehicle, the short circuit is applied through the breakout harness. The connection used for creating the short circuit (including the cabling) shall have a resistance not exceeding 5 mΩ.**

The short circuit condition shall be continued until the **protection function** operation of the REESS ~~terminate 's protection function to interrupt or limit~~ the short circuit current ~~is confirmed~~, or for at least **1 hour** ~~one hour~~ after the temperature measured on the casing of the ~~tested device~~ **Tested-Device** has stabilised, such that the temperature gradient varies by a less than 4 °C through ~~1-2~~ hours.

3.3. Standard cycle and observation period

Directly after the termination of the short circuit a standard cycle as described in Annex ~~8~~ **9**, Appendix 1 shall be conducted, if not inhibited by the ~~tested device~~ **Tested-Device**.

The test shall end with an observation period of 1 hour at the ambient temperature conditions of the test environment."

*Annex 8G (former), renumber as Annex 9G, and amend to read:*

## "Annex ~~8G~~ **9G**

### Overcharge Protection

1. Purpose

The purpose of this test is to verify the performance of the overcharge protection **to prevent the REESS from any further related severe events caused by a too high SOC.**

2. Installations

This test shall be conducted, under standard operating conditions, either **with a complete vehicle or** with the complete REESS ~~(this maybe a complete vehicle) or with related REESS subsystem(s), including the cells and their electrical connections. If the manufacturer chooses to test with related subsystem(s), the manufacturer shall demonstrate that the test result can reasonably represent the performance of the complete REESS with respect to~~

~~its safety performance under the same conditions.~~ **Ancillary systems that do not influence the test results may be omitted from the Tested-Device.**

The test may be performed with a modified ~~tested device~~ **Tested-Device** as agreed by the manufacturer and the Technical Service, **provided** ~~that~~ these modifications shall not influence the test results.

3. Procedures

3.1. General test conditions

The following requirements and conditions shall apply to the test:

- (a) The test shall be conducted at an ambient temperature of  $20 \pm 10$  °C or at higher temperature if requested by the manufacturer;
- (b) **The SOC of REESS shall be adjusted around the middle of normal operating range by normal operation recommended by the manufacturer such as driving the vehicle or using an external charger. The accurate adjustment is not required as long as the normal operation of the REESS is enabled;**
- (c) **For vehicle-based test of vehicles with on-board energy conversion systems (e.g. internal combustion engine, fuel cell, etc.), fill the fuel to allow the operation of such energy conversion systems;**
- (d) At the beginning of the test, all protection devices which would affect the function of the ~~tested device~~ **Tested-Device** and which are relevant to the outcome of the test shall be operational. **All relevant main contactors for charging shall be closed.**

3.2. Charging

~~At the beginning all relevant main contactors for charging shall be closed.~~

~~The charge control limits of the test equipment shall be disabled.~~

~~The tested device shall be charged with a charge current of at least 1/3C rate but not exceeding the maximum current within the normal operating range as specified by the manufacturer.~~

~~The charging shall be continued until the tested device (automatically) interrupts or limits the charging. Where an automatic interrupt function fails to operate, or if there is no such function the charging shall be continued until the tested device is charged to twice of its rated charge capacity.~~

**The procedure for charging the REESS for vehicle-based test shall be in accordance with paragraphs 3.2.1. and 3.2.2. and shall be selected as appropriate for the relevant mode of vehicle operation and the functionality of the protection system. Alternatively, the procedure for charging the REESS for vehicle-based test shall be in accordance with paragraph 3.2.3. For component-based test, the charging procedure shall be in accordance with paragraph 3.2.4.**

3.2.1. Charge by vehicle operation.

**This procedure is applicable to the vehicle-based tests in active driving possible mode:**

- (a) **For vehicles that can be charged by on-board energy sources (e.g. energy recuperation, on-board energy conversion systems), the vehicle shall be driven on a chassis dynamometer. The vehicle operation on a chassis dynamometer (e.g. simulation of continuous down-hill driving) that will deliver as high charging current as reasonably achievable shall be determined, if necessary, through consultation with the manufacturer.**

- (b) The REESS shall be charged by the vehicle operation on a chassis dynamometer in accordance with paragraph 3.2.1.(a). The vehicle operation on the chassis dynamometer shall be terminated when the vehicle's overcharge protection controls terminates the REESS charge current or the temperature of the REESS is stabilized such that the temperature varies by a gradient of less than 2 °C through 1 hour. Where an automatic interrupt function vehicle's overcharge protection control fails to operate, or if there is no such control function, the charging shall be continued until the REESS temperature reaches 10 °C above its maximum operating temperature specified by the manufacturer.
- (c) Immediately after the termination of charging, one standard cycle as described in Annex 9, Appendix 1 shall be conducted, if it is not prohibited by the vehicle, with vehicle operation on a chassis dynamometer.

**3.2.2. Charge by external electricity supply (vehicle-based test).**

This procedure is applicable to vehicle-based test for externally chargeable vehicles:

- (a) The vehicle inlet for normal use, if it exists, shall be used for connecting the external electricity supply equipment. The charge control communication of the external electricity supply equipment shall be altered or disabled to allow the charging specified in paragraph 3.2.2.(b) below;
- (b) The REESS shall be charged by the external electricity supply equipment with the maximum charge current specified by the manufacturer. The charging shall be terminated when the vehicle's overcharge protection control terminates the REESS charge current. Where vehicle's overcharge protection control fails to operate, or if there is no such control, the charging shall be continued until the REESS temperature reaches 10 °C above its maximum operating temperature specified by the manufacturer. In the case where charge current is not terminated and where the REESS temperature remains less than 10 °C above the maximum operating temperature, vehicle operation shall be terminated 12 hours after the start of charging by external electricity supply equipment;
- (c) Immediately after the termination of charging, one standard cycle as described in Annex 9, Appendix 1 shall be conducted, if it is not prohibited by the vehicle, with vehicle operation on a chassis dynamometer for discharging and with external electricity supply equipment for charging.

**3.2.3. Charge by connecting breakout harness (vehicle-based test).**

This procedure is applicable to vehicle-based tests for both externally chargeable vehicles and vehicles that can be charged only by on-board energy sources and for which the manufacturer provides information to connect a breakout harness to a location just outside the REESS that permits charging of the REESS:

- (a) The breakout harness is connected to the vehicle as specified by the manufacturer. The trip current/voltage setting of the external charge-discharge equipment shall be at least 10 per cent higher than the current/voltage limit of the Tested-Device. The external electricity supply equipment is connected to the breakout harness. The REESS shall be charged by the external electricity power



supply with the maximum charge current specified by the manufacturer;

- (b) The charging shall be terminated when the vehicle's overcharge protection control terminates the REESS charge current. Where vehicle's overcharge protection control fails to operate, or if there is no such control, the charging shall be continued until the REESS temperature is 10 °C above its maximum operating temperature specified by the manufacturer. In the case where charge current is not terminated and where the REESS temperature remains less than 10 °C above the maximum operating temperature, vehicle operation shall be terminated 12 hours after the start of charging by external electricity supply equipment;
- (c) Immediately after the termination of charging, one standard cycle as described in Annex 9, Appendix 1 (for a complete vehicle) shall be conducted, if it is not prohibited by the vehicle.

**3.2.4. Charge by external electricity supply (component-based test).**

This procedure is applicable to component-based test:

- (a) The external charge/discharge equipment shall be connected to the main terminals of the REESS. The charge control limits of the test equipment shall be disabled;
- (b) The REESS shall be charged by the external charge/discharge equipment with the maximum charge current specified by the manufacturer. The charging shall be terminated when the REESS overcharge protection control terminates the REESS charge current. Where overcharge protection control of the REESS fails to operate, or if there is no such control, the charging shall be continued until the REESS temperature reaches 10 °C above its maximum operating temperature specified by the manufacturer. In the case where charge current is not terminated and where the REESS temperature remains less than 10 °C above the maximum operating temperature, the charging shall be terminated 12 hours after the start of charging by external electricity supply equipment;
- (c) Immediately after the termination of charging, one standard cycle as described in Annex 9, Appendix 1 shall be conducted, if it is not prohibited by the REESS, with external charge-discharge equipment.

**3.3. ~~Standard cycle and observation period~~**

~~Directly after the termination of charging a standard cycle as described in Annex 8, Appendix 1 shall be conducted, if not inhibited by the tested device.~~

**The test shall end with an observation period of 1 hour at the ambient temperature conditions of the test environment. "**

*Annex 8H (former), renumber as Annex 9H and amend to read:*

## **"Annex 8H9H**

### **Over-Discharge Protection**

**1. Purpose**

The purpose of this test is to verify the performance of the over-discharge protection. ~~This functionality, if implemented, shall interrupt or limit the discharge current to prevent the REESS from any severe events caused by a too low SOC as specified by the manufacturer.~~

2. Installations

This test shall be conducted, under standard operating conditions, either **with a complete vehicle or** with the complete REESS ~~(this maybe a complete vehicle) or with related REESS subsystem(s), including the cells and their electrical connections.~~ **Ancillary systems that do not influence the test results may be omitted from the Tested-Device.** ~~If the manufacturer chooses to test with related subsystem(s), the manufacturer shall demonstrate that the test result can reasonably represent the performance of the complete REESS with respect to its safety performance under the same conditions.~~

The test may be performed with a modified ~~tested device~~ **Tested-Device** as ~~agreed by the manufacturer and the Technical Service.~~ **provided** ~~These~~ modifications shall not influence the test results

3. Procedures

3.1. General test conditions

The following requirements and condition shall apply to the test:

- (a) The test shall be conducted at an ambient temperature of  $20\text{ }^{\circ}\text{C} \pm 10\text{ }^{\circ}\text{C}$  or at higher temperature if requested by the manufacturer;
- (b) **The SOC of REESS shall be adjusted at the low level, but within normal operating range, by normal operation recommended by the manufacturer, such as driving the vehicle or using an external charger. Accurate adjustment is not required as long as the normal operation of the REESS is enabled;**
- (c) **For vehicle-based test of vehicles with on-board energy conversion systems (e.g. internal combustion engine, fuel cell, etc.), reduce the electrical energy from such on-board energy conversion systems, for example by adjusting the fuel level to nearly empty but enough so that the vehicle can enter into active driving possible mode;**
- (d) At the beginning of the test, all protection devices which would affect the function of the ~~tested device~~ **Tested-Device** and which are relevant for the outcome of the test shall be operational.

3.2. Discharging

**The procedure for discharging the REESS for vehicle-based test shall be in accordance with paragraphs 3.2.1. and 3.2.2. Alternatively, the procedure for discharging the REESS for vehicle-based test shall be in accordance with paragraph 3.2.3. For the component-based test, the discharging procedure shall be in accordance with paragraph 3.2.4.**

3.2.1. Discharge by vehicle driving operation.

**This procedure is applicable to the vehicle-based tests in active driving possible mode:**

- (a) **The vehicle shall be driven on a chassis dynamometer. The vehicle operation on a chassis dynamometer (e.g. simulation of continuous driving at steady speed) that will deliver as constant discharging power as reasonably achievable shall be determined, if necessary, through consultation with the manufacturer;**
- (b) **The REESS shall be discharged by the vehicle operation on a chassis dynamometer in accordance with paragraph 3.2.1.(a). The vehicle operation on the chassis dynamometer shall be terminated when the vehicle's over-discharge protection control terminates REESS discharge current or the temperature of the REESS is stabilized such that the temperature varies by a gradient of less than  $4\text{ }^{\circ}\text{C}$  through 2 hours. Where an over-discharge protection control fails to operate, or if there is no such control, then the**

discharging shall be continued until the REESS is discharged to 25 per cent of its nominal voltage level;

- (c) Immediately after the termination of discharging, one standard charge followed by a standard discharge as described in Annex 9, Appendix 1 shall be conducted if it is not prohibited by the vehicle.

**3.2.2. Discharge by auxiliary electrical equipment (vehicle-based test).**

This procedure is applicable to the vehicle-based tests in stationary condition:

- (a) The vehicle shall be switched in to a stationary operation mode that allow consumption of electrical energy from REESS by auxiliary electrical equipment. Such an operation mode shall be determined, if necessary, through consultation with the manufacturer. Equipment (e.g. wheel chocks) that prevent the vehicle movement may be used as appropriate to ensure the safety during the test;
- (b) The REESS shall be discharged by the operation of electrical equipment, air-conditioning, heating, lighting, audio-visual equipment, etc., that can be switched on under the conditions given in paragraph 3.2.2.(a). The operation shall be terminated when the vehicle's over-discharge protection control terminates REESS discharge current or the temperature of the REESS is stabilized such that the temperature varies by a gradient of less than 4 °C through 2 hours. Where an over-discharge protection control fails to operate, or if there is no such control, then the discharging shall be continued until the REESS is discharged to 25 per cent of its nominal voltage level;
- (c) Immediately after the termination of discharging, one standard charge followed by a standard discharge as described in Annex 9, Appendix 1 shall be conducted if it is not prohibited by the vehicle.

**3.2.3. Discharge of REESS using discharge resistor (vehicle-based test).**

This procedure is applicable to vehicles for which the manufacturer provides information to connect a breakout harness to a location just outside the REESS that permits discharging the REESS:

- (a) Connect the breakout harness to the vehicle as specified by the manufacturer. Place the vehicle in active driving possible mode;
- (b) A discharge resistor is connected to the breakout harness and the REESS shall be discharged at a discharge rate under normal operating conditions in accordance with manufacturer provided information. A resistor with discharge power of 1 kW may be used;
- (c) The test shall be terminated when the vehicle's over-discharge protection control terminates REESS discharge current or the temperature of the REESS is stabilized such that the temperature varies by a gradient of less than 4 °C through 2 hours. Where an automatic discharge interrupt function fails to operate, or if there is no such function, then the discharging shall be continued until the REESS is discharged to 25 per cent of its nominal voltage level;
- (d) Immediately after the termination of discharging, one standard charge followed by a standard discharge as described in Annex 9, Appendix 1 shall be conducted if it is not prohibited by the vehicle.

**3.2.4. Discharge by external equipment (component-based test).**

This procedure is applicable to component-based test:

- (a) All relevant main contactors shall be closed. The external charge-discharge shall be connected to the main terminals of the Tested-Device;
- (b) A discharge shall be performed with a stable current within the normal operating range as specified by the manufacturer;
- (c) The discharging shall be continued until the Tested-Device (automatically) terminates REESS discharge current or the temperature of the Tested-Device is stabilized such that the temperature varies by a gradient of less than 4 °C through 2 hours. Where an automatic interrupt function fails to operate, or if there is no such function, then the discharging shall be continued until the Tested-Device is discharged to 25 per cent of its nominal voltage level;
- (d) Immediately after the termination of the discharging, one standard charge followed by a standard discharge as described in Annex 9, Appendix 1 shall be conducted if not inhibited by the Tested-Device.

At the beginning of the test, all relevant main contactors shall be closed.

~~A discharge shall be performed with at least 1/3 C rate but shall not exceed the maximum current within the normal operating range as specified by the manufacturer.~~

~~The discharging shall be continued until the tested device (automatically) interrupts or limits the discharging. Where an automatic interrupt function fails to operate, or if there is no such function then the discharging shall be continued until the tested device is discharged to 25 per cent of its nominal voltage level.~~

3.3. ~~Standard charge and observation period~~

~~Directly after termination of the discharging the tested device shall be charged with a standard charge as specified in Annex 8, Appendix 1 if not inhibited by the tested device. The test shall end with an observation period of 1 hour at the ambient temperature conditions of the test environment."~~

*Annex 8I (former), renumber as Annex 9I, and amend to read:*

## "Annex 8I9I

### Over-Temperature Protection

1. Purpose

The purpose of this test is to verify the performance of the protection measures of the REESS against internal overheating during the operation, ~~even under the failure of the cooling function if applicable~~. In the case that no specific protection measures are necessary to prevent the REESS from reaching an unsafe state due to internal over-temperature, this safe operation must be demonstrated.

2. Installations

~~2.1. The test may be conducted with a complete REESS according to paragraphs 3. and 4. or with a complete vehicle according to paragraphs 5. and 6.~~

3. Installation for test conducted using a complete REESS

3.1. Ancillary systems that do not influence to the test results may be omitted from the Tested-Device. The test may be performed with a modified

**Tested-Device provided these modifications shall not influence the test results.**

~~The following test may be conducted with the complete REESS (maybe as a complete vehicle) or with related REESS subsystem(s), including the cells and their electrical connections. If the manufacturer chooses to test with related subsystem(s), the manufacturer shall demonstrate that the test result can reasonably represent the performance of the complete REESS with respect to its safety performance under the same conditions. The test may be performed with a modified tested device as agreed by the manufacturer and the Technical Service. These modifications shall not influence the test results.~~

- 23.2. Where a REESS is fitted with a cooling function and where the REESS will remain functional **in delivering its normal power** without a cooling function system being operational, the cooling system shall be deactivated for the test.
- 23.3. The temperature of the ~~tested device~~**Tested-Device** shall be continuously measured inside the casing in the proximity of the cells during the test in order to monitor the changes of the temperature. The on-board sensor, if existing may be used **with compatible tools to read the signal**. ~~The manufacturer and Technical Service shall agree on the location of the temperature sensor(s) used.~~
- 3.4. **The REESS shall be placed in a convective oven or climatic chamber. If necessary, for conducting the test, the REESS shall be connected to the rest of vehicle control system with extended cables. An external charge/discharge equipment may be connected under supervision by the vehicle manufacturer.**

#### 4. **Test procedures for test conducted using a complete REESS.**

##### ~~3.~~ **Procedures**

- 34.1. At the beginning of the test, all protection devices which affect the function of the ~~tested device~~**Tested-Device** and are relevant to the outcome of the test shall be operational, except for any system deactivation implemented in accordance with paragraph 23.2. above.
- 34.2. ~~During the test, t~~The ~~tested device~~**Tested-Device** shall be continuously charged and discharged **by the external charge/discharge equipment** with a ~~steady~~ current that will increase the temperature of cells as rapidly as possible within the range of normal operation as defined by the manufacturer **until the end of the test**.  
**Alternatively, the charge and discharge may be conducted by vehicle driving operations on chassis dynamometer where the driving operation shall be determined through consultation with the manufacturer to achieve the conditions above.**
- 34.3. ~~The tested device shall be placed in a convective oven or climatic chamber.~~ The temperature of the chamber or oven shall be gradually increased, **from 20 ± 10 °C or at higher temperature if requested by the manufacturer**, until it reaches the temperature determined in accordance with paragraph 34.3.1. or 34.3.2. below as applicable, and then maintained at a temperature that is equal to or higher than this, until the end of the test.
  - 34.3.1. Where the REESS is equipped with protective measures against internal overheating, the temperature shall be increased to the temperature defined by the manufacturer as being the operational temperature threshold for such protective measures, to insure that the temperature of the ~~tested device~~**Tested-Device** will increase as specified in paragraph 34.2. above.
  - 34.3.2. Where the REESS is not equipped with any specific measures against internal over-heating, the temperature shall be increased to the maximum operational temperature specified by the manufacturer.
- 34.4. The end of test: The test will end when one of the followings is observed:

- (a) The ~~tested device~~**Tested-Device** inhibits and/or limits the charge and/or discharge to prevent the temperature increase;
- (b) The temperature of the ~~tested device~~**Tested-Device** is stabilised, which means that the temperature varies by a gradient of less than 4 °C through 2 hours;
- (c) Any failure of the acceptance criteria prescribed in paragraph 6.9.2.1. of the Regulation.

**5. Installation for test conducted using a complete vehicle.**

**5.1. Based on information from the manufacturer, for a REESS fitted with a cooling function the cooling system shall be disabled or in a state of significantly reduced operation (for a REESS that will not operate if the cooling system is disabled) for the test.**

**5.2. The temperature of the REESS shall be continuously measured inside the casing in the proximity of the cells during the test to monitor the changes of temperature using on-board sensors and compatible tools according to manufacturer provided information for reading the signals.**

**5.3. The vehicle shall be placed in a climate control chamber set to a temperature between 40 °C to 45 °C for at least 6 hours.**

**6. Test procedures for test conducted using a complete vehicle.**

**6.1. The vehicle shall be continuously charged and discharged in a manner that will increase the temperature of REESS cells as rapidly as possible within the range of normal operation as defined by the manufacturer until the end of the test.**

**The charge and discharge will be conducted by vehicle driving operations on chassis dynamometer where the driving operation shall be determined through consultation with the manufacturer to achieve the conditions above.**

**For a vehicle that can be charged by an external power supply, the charging may be conducted using an external power supply if more rapid temperature increase is expected.**

**6.2. The test will end when one of the followings is observed:**

- (a) **The vehicle terminates the charge and/or discharge;**
- (b) **The temperature of the REESS is stabilized such that the temperature varies by a gradient of less than 4 °C through 2 hours;**
- (c) **Any failure of the acceptance criteria prescribed in paragraph 6.9.2.1. of the Regulation;**
- (d) **Three hours elapse from the time of starting the charge/discharge cycles in paragraph 6.1. "**

*Insert new Annex 9J, to read:*

## **"Annex 9J**

### **Over-Current Protection**

**1. Purpose**

The purpose of this test is to verify the performance of the overcurrent protection during DC external charging to prevent the REESS from any severe events caused by excessive levels of charge current as specified by the manufacturer.

**2. Test conditions:**

- (a) The test shall be conducted at an ambient temperature of  $20 \pm 10$  °C;
- (b) The SOC of REESS shall be adjusted around the middle of normal operating range by normal operation recommended by the manufacturer such as driving the vehicle or using an external charger. The accurate adjustment is not required as long as the normal operation of the REESS is enabled;
- (c) The overcurrent level (assuming failure of external DC electricity supply equipment) and maximum voltage (within normal range) that can be applied shall be determined, if necessary, through consultation with the manufacturer.

**3. The overcurrent test shall be conducted in accordance with paragraph 4. or paragraph 5., as applicable and in accordance with manufacturer information.**

**4. Overcurrent during charging by external electricity supply.**

This test procedure is applicable to vehicle-based test for vehicles that have the capability of charging by DC external electricity supply:

- (a) The DC charging vehicle inlet shall be used for connecting the external DC electricity supply equipment. The charge control communication of the external electricity supply equipment is altered or disabled to allow the overcurrent level determined through consultation with the manufacturer;
- (b) Charging of the REESS by the external DC electricity supply equipment shall be initiated to achieve the highest normal charge current specified by the manufacturer. The charge current is then increased over 5 seconds from the highest normal charge current to the overcurrent level determined in accordance with paragraph 2.(c) above. Charging is then continued at this overcurrent level;
- (c) The charging shall be terminated when the functionality of the vehicle's overcurrent protection terminates the REESS charge current or the temperature of the REESS is stabilized such that the temperature varies by a gradient of less than 4 °C through 2 hours;
- (d) Immediately after the termination of charging, one standard cycle as described in Annex 9, Appendix 1 shall be conducted, if it is not prohibited by the vehicle.

**5. Overcurrent during charging using breakout harness.**

This test procedure is applicable to REESS for vehicles that have the capability of charging by DC external electricity supply and for which the

**manufacturer provides information to connect a breakout harness to a location just outside the REESS that permits charging of the REESS:**

- (a) The breakout harness is connected to the vehicle or REESS as specified by the manufacturer;**
- (b) The external electricity supply equipment along with the overcurrent supply is connected to the breakout harness and charging of the REESS is initiated to achieve the highest normal charge current specified by the manufacturer;**
- (c) The charge current is then increased over 5 seconds from the highest normal charge current to the overcurrent level determined in accordance with paragraph 2.(c) above. Charging is then continued at this overcurrent level;**
- (d) The charging shall be terminated when the functionality of the vehicle's overcurrent protection terminates charging or the temperature of the Tested-Device is stabilized such that the temperature varies by a gradient of less than 4 °C through 2 hours;**
- (e) Immediately after the termination of charging, one standard cycle as described in Annex 9, Appendix 1 shall be conducted, if it is not prohibited by the vehicle.**

- 6. The test shall end with an observation period of 1 hour at the ambient temperature conditions of the test environment."**

*Annex 9B (former), renumber as Annex 10B.*

---



## II. Justification

1. The objective of this proposal is to update the requirements for electric vehicles of category L in UN Regulation No. 136, by aligning them to the state-of-the-art provisions from the new 03 series to UN Regulation No. 100 and UN GTR No. 20, the counterpart regulations for vehicles of categories M and N.
  2. In this proposal, the scope of Part I to UN Regulation No. 136 is clarified in line with the 03 series to UN Regulation No. 100, as it effectively applies to vehicles that do not operate on high voltage but are equipped with a REESS (subject to the requirements of Part II). Low-voltage vehicles shall be subject to Part I, except for the protection against electrical shock (paragraph 5.1.).
  3. For consistency, the relevant terminology and definitions of this regulation are aligned with those in UN Regulation No. 100.
  4. Additional requirements on REESS warnings are also carried over from the new series to UN Regulation No. 100, introducing additional safety benefits. The new requirements in Part I define the warnings at the vehicle level, while those in Part II specify the detection and generation of signal.
  5. Alternative specifications for isolation resistance monitoring system as a measure for protection against water effect have been introduced in line with the new option in UN GTR No. 20 and UN Regulation No. 100.
  6. The following tests for the REESS have been transferred from UN Regulation No. 100: overcurrent protection for DC-charging; low-temperature protection warning in the event of failure of vehicle controls for safe operation; warning in the case of thermal event; thermal propagation; and management of gases emitted. Particularly, the two latter are intended to notify the driver to prevent a hazardous situation for the occupants of the vehicle interior when a passenger compartment exists.
  7. In line with UN Regulation No. 100, the venting as a pass/fail criterion is introduced for REESS other than open-type traction batteries for a number of in-use REESS tests such as vibration, thermal shock and cycling and others, to avoid human harm that may occur due to potential toxic or corrosive emissions that may reach the passenger compartment, if equipped.
  8. The administrative provisions of this Regulation are updated to refer to the corresponding Schedule of Revision 3 of the 1958 Agreement.
  9. Considering the various new or modified test requirements, and introduction of new features such as the introduction of new warnings (detection and notification), transitional provisions are required.
  10. Further to the above, new optional requirements have been added to enable the mounting of removable REESS in any orientation, to enable safe deployment of swappable batteries.
-