

Tracking of amendments to UN Regulation No. 158 (Reversing motion)

The text reproduced below was prepared by the experts from the IWG VRU-Proxi. It aims at helping the reader to track the changes proposed in GRSG/2021/5 and in GRSG-121-08. The modifications to the current text of the UN Regulations are **blue** and marked in bold for new or strikethrough for deleted characters.

"UN Regulation No. [XXX]¹

UN Regulation on uniform provisions concerning the approval of devices ~~and motor vehicles for reversing motion~~ ~~and motor vehicles~~ with regard to the driver's awareness of vulnerable road users behind vehicles ~~when reversing~~

Contents

Page²

Regulation

1.	Scope	
I.	Devices for means of rear visibility Reversing Motion	
2.	Definitions	
3.	Application for approval	
4.	Markings	
5.	Approval	
6.	Requirements	
7.	Modification of the type of device for means of rear visibility indirect vision and extension of approval	
8.	Conformity of production	
9.	Penalties for non conformity of production.....	
10.	Production definitively discontinued.....	
11.	Names and addresses of Technical Services responsible for conducting approval tests, and of Type Approval Authorities.....	
II.	Installation of means of rear visibility or detection devices for reversing motion	
12.	Definitions	
13.	Application for approval	
14.	Approval	
15.	Requirements.....	
16.	Requirements for rear-view camera system	
17.	Requirements for detection systems	
18.	Modifications of the vehicle type and extension of approvals	
19.	Conformity of production.....	
20.	Penalties for non-conformity of protection	
21.	Production definitively discontinued.....	
22.	Names and addresses of Technical Services responsible for conducting approval tests, and of Type Approval Authorities.....	

¹ The Regulation number will be known at the time of entry into force of this UN Regulation. [XXX] is intended to be replaced by the Regulation number once known.

² Page numbers will be added at a later stage.

Annexes

- 1 Information document for type approval of a device for **means of rear visibility reversing motion**
- 2 Information document for type approval of vehicle with respect to the installation of **means of rear visibility or detection devices for reversing motion**
- 3 Communication concerning the approval or refusal or extension or withdrawal of approval or production definitively discontinued of a type of device (**Separate Technical Unit**) for **means of rear visibility reversing motion**, pursuant to Regulation No. [158]
- 4 Communication concerning the approval or refusal or extension or withdrawal of approval or production definitively discontinued of a type of vehicle with regard to the mounting of devices for reversing motion, pursuant to Regulation No. [XXX]
- Appendix
- 5 Arrangement of approval mark for a device for **means of rear visibility indirect vision**
- 6 Test method for determining reflectivity
- 7 Procedure for determining the radius of curvature "r" of the reflecting surface of a mirror
- 8 Procedure for determining the "H" point and the actual torso angle for seating positions in motor vehicles
- Appendix 1 - Description of the three-dimensional "H" point machine (3-D H machine).....
- Appendix 2 - Three-dimensional reference system
- Appendix 3 - Reference data concerning seating positions
- 9 Test methods for close-proximity rear-view field of vision
- 10 Test methods for detection systems.....

Introduction (for information)

The purpose of this Regulation is to provide the provisions for ~~reversing motion~~ **means of rear visibility and detection that would improve the driver's awareness of vulnerable road users behind vehicles when reversing** ~~concerning on awareness of vulnerable road users proximity~~. UN Regulation No. 46. provides the provisions for indirect vision of motor vehicles. This Regulation expands driver's ~~vision or~~ awareness ~~for behind~~ vehicles ~~rear direction~~ when ~~in~~ reversing ~~motion~~. Therefore, some requirements of this Regulation may be satisfied by devices complying with UN Regulation No.46.

This Regulation cannot cover all the traffic conditions and infrastructure features in the type approval process; this Regulation recognises that the performances required in this Regulation cannot be achieved in all conditions (vehicle speed and condition, weather conditions, and traffic scenarios etc. may affect the system performances).

1. Scope

This Regulation applies to:

- 1.1. Approval of devices for **means of rear visibility** ~~reversing safety~~ defined in Part I intended to be fitted to vehicles of category M and N.
- 1.2. Approval of vehicle installation of ~~devices for~~ **means of rear visibility or detection** ~~reversing safety~~ defined in Part II if fitted to vehicles of category M and N.
- 1.3. At the request of the manufacturer, Contracting Parties may grant approvals under Parts I and II to vehicles of other categories and devices for fitting to such vehicles.
- 1.4. The following vehicles of category M and N shall be exempted from this Regulation:

Vehicles where installation of ~~any device for~~ **means of rear visibility or detection** ~~reversing safety~~ is incompatible with their on-road use may be partly or fully exempted from this Regulation, subject to the decision of the Type Approval Authority
- 1.5. If a vehicle has multiple device(s), the manufacturer shall designate the device that meets the provisions of the regulation.

Part I **Devices for ~~Reversing Motion~~ means of rear visibility**

2. Definitions

For the purposes of this Regulation:

- 2.1. "*Devices for **means of rear visibility or detection** ~~reversing motion~~*" means devices intended, **when reversing**, to give a clear view of the rear of the vehicle within the fields of vision defined in paragraph 15.2. **or intended to detect objects in the field of detection defined in paragraph 15.3.**

These can be conventional mirrors, Rear-View Camera System, **detection systems** or other devices ~~able to present information about the field of vision to the driver.~~
- 2.1.1. "*Close-proximity rear-view device*" means a device that gives the field of vision defined in paragraph 15.2. of this Regulation.
- 2.1.2. "*Devices for **means of rear visibility** ~~indirect vision~~*" means devices that present information of the fields of vision defined in paragraph 15.2.

- 2.1.2.1. "*Rear-View Camera system (RVCS)*" means any system intended to render an image of the outside world and give a clear view to the rear of the vehicle within the fields of vision defined in paragraph 15.2. by means of camera.
- 2.1.2.1.1. "*Luminance contrast*" means the brightness ratio between an object and its immediate background/surrounding that allows the object to be distinguished from its background/surroundings. The definition is in accordance with the definition given in ISO 9241-302:2008.
- 2.1.2.1.2. "*Resolution*" means the smallest detail that can be discerned with a perceptual system, i.e. perceived as separate from the larger whole. The resolution of the human eye is indicated as "visual acuity".
- 2.1.2.1.3. "*Visual spectrum*" means light with a wavelength within the range of the perceptual limits of the human eyes: 380-780 nm.
- 2.1.2.2. "*Close-proximity rear-view mirror*" means any device, excluding devices such as periscopes, intended to give a clear view to the rear of the vehicle within the fields of vision defined in paragraph 15.2. by means of a reflective surface.
- 2.1.2.2.1. "*r*" means the average of the radii of curvature measured over the reflecting surface, in accordance with the method described in Annex 7.
- 2.1.2.2.2. "*The principal radii of curvature at one point on the reflecting surface (ri)*" means the values obtained with the apparatus defined in Annex 7, measured on the arc of the reflecting surface passing through the centre of this surface parallel to the segment b, as defined in paragraph 6.1.2.1.2. of this Regulation and on the arc perpendicular to this segment.
- 2.1.2.2.3. "*The radius of curvature at one point on the reflecting surface (rp)*" means the arithmetical average of the principal radii of curvature r_i and r'_i , i.e.:

$$r_p = \frac{r_i + r'_i}{2}$$

- 2.1.2.2.4. "*Spherical surface*" means a surface, which has a constant and equal radius in all directions.
- 2.1.2.2.5. "*Aspherical surface*" means a surface, which has only in one plane a constant radius.
- 2.1.2.2.6. "*Aspherical mirror*" means a mirror composed of a spherical and an aspherical part, in which the transition of the reflecting surface from the spherical to the aspherical part has to be marked. The curvature of the main axis of the mirror is defined in the x/y coordinate system defined by the radius of the spherical primary calotte with:

$$y = R - \sqrt{(R^2 - x^2) + k(x - a)^3}$$

Where:

R: nominal radius in the spherical part

k: constant for the change of curvature

a: constant for the spherical size of the spherical primary calotte

- 2.1.2.2.7. "*Centre of the reflecting surface*" means the centre of the visible area of the reflecting surface.
- 2.1.2.2.8. "*The radius of curvature of the constituent parts of the mirror*" means the radius "c" of the arc of the circle which most closely approximates to the curved form of the part in question.

- 2.1.2.3. "Other devices for **means of rear visibility indirect-vision** " means devices as defined in paragraph 2.1.2. above, where the field of vision is not obtained by means of a mirror or a Rear-View Camera System.
- 2.1.3. "Test object" means a cylindrical object with a height of 0.8 m and a diameter of 0.30 m.
- 2.1.4. "Field of vision" means the section of the tri-dimensional space above ground level which is monitored with the help of a device for indirect vision. Unless otherwise stated, this is based on the view offered by a device and/or devices other than mirrors. This may be limited by the relevant detection distance corresponding to the test object.
- 2.1.5. "Detection System" means a system which uses signals to enable the driver to detect objects in the area adjacent to the vehicle.
- 2.1.5.1. "Audible information" means information using auditory signals provided by a detection system as defined in paragraph 2.1.5. above to enable the driver to detect objects in the area adjacent to the vehicle.
- 2.1.5.2. "Optical information" means information using optical signals provided by a detection system as defined in paragraph 2.1.5. above to enable the driver to detect objects in the area adjacent to the vehicle.
- 2.1.5.3. "Haptic information" means information using haptic signals provided by a detection system as defined in paragraph 2.1.5. above to enable the driver to detect objects in the area adjacent to the vehicle.
- 2.1.6. "Field of detection" means the section of the tri-dimensional space above ground level which is monitored with the help of a detection system.
- 2.2. "Type of device for **means of rear visibility or detection Reversing Safety** " means devices that do not differ on the following essential characteristics:
- (a) Design of the device inclusive, if pertinent, the attachment to the bodywork;
 - (b) In the case of mirrors, the shape, the dimensions and radius of curvature of the mirror's reflecting surface;
 - (c) In the case of Rear-View Camera System, the field of view, the magnification.
 - (d) In the case of detection systems, the sensor type, the information signal type.

3. Application for approval

- 3.1. The application for approval of a type of device for **means of rear visibility indirect-vision** shall be submitted by the holder of the trade name or mark or by his duly accredited representative.
- 3.2. A model of information document is shown in Annex 1.
- 3.3. For each type of device for **means of rear visibility indirect-vision** the application shall be accompanied by three samples of the parts.
- ~~3.4. The RVCS shall be provided by the applicant with the following documents:~~
- ~~(a) Technical specification of the RVCS; and~~
 - ~~(b) Operator's manual.~~

4. Markings

- 4.1. The samples of devices for **means of rear visibility indirect vision** submitted for approval shall bear the trade name or mark of the manufacturer; this marking shall be clearly legible and be indelible.
- 4.2. Every device for **means of rear visibility indirect vision** shall possess, on at least one of the main components, a space large enough to accommodate the approval mark, which shall be legible; this space shall be shown on the drawings referred to in Annex 1. The approval mark shall also be legible when the device is mounted on the vehicle ~~with the exception of Rear View Camera System as defined in paragraph 2.1.2. or a detection system as defined in paragraph 2.1.5.~~ Other components of the device shall bear a means of identification. In the case of limited space for the approval mark(s), other means of identification that link it to the approval mark shall be provided.

5. Approval

- 5.1. If the samples submitted for approval meet the requirements of paragraph 6. of this Regulation, approval of the pertinent type of device for **means of rear visibility indirect vision** shall be granted.
- 5.2. An approval number shall be assigned to each type approved. Its first two digits (at present 00) shall indicate the series of amendments incorporating the most recent major technical amendments made to the Regulation at the time of issue of the approval. The same Contracting Party shall not assign the same number to another type of device for **means of rear visibility indirect vision**.
- 5.3. Notice of approval or of refusal or of extension or withdrawal of approval or of production definitively discontinued of a type of device for **means of rear visibility indirect vision** pursuant to this Regulation shall be communicated to the Parties to the Agreement which apply this Regulation by means of a form conforming to the model in Annex 3 to this Regulation.
- 5.4. There shall be affixed, on at least one of the main components, conspicuously and in the space referred to in paragraph 4.2. above, to every device for **means of rear visibility indirect vision**, conforming to a type approved under this Regulation, in addition to the mark prescribed in paragraph 4.1. above, an international approval mark consisting of:
 - 5.4.1. A circle surrounding the letter "E" followed by:
 - (a) The distinguishing number of the country which has granted approval;³ and
 - (b) The number of this Regulation, followed by the letter "R", a dash and the approval number.
- 5.5. The approval mark and the additional symbol(s) shall be clearly legible and be indelible.
- 5.6. Annex 5 to this Regulation gives an example of the arrangement of the aforesaid approval mark and additional symbol.

³ The distinguishing numbers of the Contracting Parties to the 1958 Agreement are reproduced in Annex 3 to the Consolidated Resolution on the Construction of Vehicles (R.E.3), document ECE/TRANS/WP.29/78/Rev.6 - www.unece.org/trans/main/wp29/wp29wgs/wp29gen/wp29resolutions.html

6. Requirements

- 6.1. Close-proximity rear-view mirrors
 - 6.1.1. General specifications
 - 6.1.1.1. All mirrors may be adjustable.
 - 6.1.2. Special specifications
 - 6.1.2.1. Dimensions
 - 6.1.2.1.1. The contours of the reflecting surface shall be of simple geometric form and its dimensions such that the mirror provides the field of vision specified in paragraph 15.2. of this Regulation.
 - 6.1.2.1.2. The dimensions of the reflecting surface shall be such that it is possible to inscribe therein:
 - (a) A rectangle 40 mm high the base length of which, measured in millimeters, has the value "a";
 - (b) A segment which is parallel to the height of the rectangle and the length of which, expressed in millimeters, has the value "b".
 - 6.1.2.2. Reflecting surface and coefficients of reflection
 - 6.1.2.2.1. The reflecting surface of a mirror shall be either flat or spherically convex. Exterior mirrors may be equipped with an additional aspherical part provided that the main mirror fulfils the requirements of the indirect field of vision.
 - 6.1.2.2.2. Differences between the radii of curvature of mirrors
 - 6.1.2.2.2.1. The difference between r_1 or r'_1 , and r_p at each reference point shall not exceed $0.15 r$.
 - 6.1.2.2.2.2. The difference between any of the radii of curvature (r_{p1} , r_{p2} , and r_{p3}) and r shall not exceed $0.15 r$.
 - 6.1.2.2.2.3. When r is not less than 3,000 mm, the value of $0.15 r$ quoted in paragraphs 6.1.2.2.2.1. and 6.1.2.2.2.2. above is replaced by $0.25 r$.
 - 6.1.2.2.3. The value of the normal coefficient of reflection, as determined according to the method described in Annex 6, shall be not less than 40 per cent.

In the case of reflecting surfaces with a changeable degree of reflection, the "day" position shall allow the colours of the signals used for road traffic to be recognized. The value of the normal coefficient of reflection in the "night" position shall be not less than 4 per cent.
 - 6.1.2.2.4. The reflecting surface shall retain the characteristics laid down in paragraph 6.1.2.2.3. above in spite of prolonged exposure to adverse weather conditions in normal use.

~~6.2. Close proximity rear view devices for indirect vision other than mirrors~~

~~6.2.1. General requirements~~

~~6.2.1.1. The effectiveness of the RVCS and other vision supporting devices of Close-proximity rear view shall not be adversely affected by magnetic or electrical fields. This shall be demonstrated by compliance with the technical requirements and transitional provisions of UN Regulation No. 10, 05 series of amendments or any later series of amendments.~~

7. **Modification of the type of device for means of rear visibility reversing motion and extension of approval**

7.1. Every modification to an existing type of device for **means of rear visibility indirect vision** including its connection to the bodywork shall be notified to the Type Approval Authority which approved the type of device for **means of rear visibility indirect vision**. The Type Approval Authority shall then either:

- (a) Decide, in consultation with the manufacturer, that a new type-approval is to be granted; or
- (b) Apply the procedure contained in paragraph 7.1.1. (Revision) and, if applicable, the procedure contained in paragraph 7.1.2. (Extension).

7.1.1. Revision

When particulars recorded in the information folder have changed and the Type Approval Authority considers that the modifications made are unlikely to have an appreciable adverse effect and that in any case the device for **means of rear visibility indirect vision** still complies with the requirements, the modification shall be designated a "revision".

In such a case, the Type Approval Authority shall issue the revised pages of the information folder as necessary, marking each revised page to show clearly the nature of the modification and the date of re-issue. A consolidated, updated version of the information folder, accompanied by a detailed description of the modification, shall be deemed to meet this requirement.

7.1.2. Extension

The modification shall be designated an "extension" if, in addition to the change of the particulars recorded in the information folder;

- (a) Further inspections or tests are required; or
- (b) Any information on the communication document (with the exception of its attachments) has changed; or
- (c) Approval to a later series of amendments is requested after its entry into force.

7.2. Confirmation or refusal of approval, specifying the alterations shall be communicated by the procedure specified in paragraph 5.3. above to the Parties to the Agreement which apply this Regulation. In addition, the index to the information package, attached to the communication document, shall be amended accordingly to show the date of the most recent revision or extension.

7.3. The Type Approval Authority issuing the extension of approval shall assign a series number to each communication form drawn up for such an extension.

8. **Conformity of production**

8.1. The conformity of production procedure shall comply with those set out in the Agreement, Schedule 1 (E/ECE/TRANS/505/Rev.3).

8.2. Every device for **means of rear visibility indirect vision** approved under this Regulation shall be so manufactured as to conform to the type approved by meeting the requirements set out in paragraph 6. above.

9. Penalties for non-conformity of production

- 9.1. The approval granted in respect of a type of device for **means of rear visibility indirect-vision** pursuant to this Regulation may be withdrawn if the requirement laid down in paragraph 8.1. above is not complied with or if the type of device for **means of rear visibility indirect-vision** did not satisfy the requirements prescribed in paragraph 8.2. above.
- 9.2. If a Contracting Party to the Agreement which applies this Regulation withdraws an approval it has previously granted, it shall forthwith so notify the other Contracting Parties applying this Regulation by means of a copy of the communication form bearing at the end, in large letters, the signed and dated annotation "APPROVAL WITHDRAWN".

10. Production definitively discontinued

If the holder of the approval completely ceases to manufacture a type of device for **means of rear visibility indirect-vision** approved in accordance with this Regulation, he shall so inform the Type Approval Authority which granted the approval. Upon receiving the relevant communication, the Authority shall inform thereof the other Parties to the Agreement applying this Regulation by means of a copy of the approval form bearing at the end, in large letters, the signed and dated annotation "PRODUCTION DISCONTINUED".

11. Names and addresses of Technical Services responsible for conducting approval tests, and of Type Approval Authorities

The Contracting Parties to the Agreement applying this Regulation shall communicate to the United Nations Secretariat the names and addresses of the Technical Services responsible for conducting approval tests and of the Type Approval Authorities which grant approval and to which forms certifying approval or refusal or extension or withdrawal of approval, issued in other countries, are to be sent.

Part II Installation of **means of rear visibility or detection devices for reversing motion**

12. Definitions

For the purpose of this Regulation:

- 12.1. "*The driver's ocular points*" means two points 65 mm apart and 635 mm vertically above point R of the driver's seat as defined in Annex 8. The straight line joining these points runs perpendicular to the vertical longitudinal median plane of the vehicle. The centre of the segment joining the two ocular points is in a vertical longitudinal plane which shall pass through the centre of the driver's designated seating position, as specified by the vehicle manufacturer.
- 12.2. "*Ambinocular vision*" means the total field of vision obtained by the superimposition of the monocular fields of the right eye and the left eye (see Figure 2 below).

Figure 2

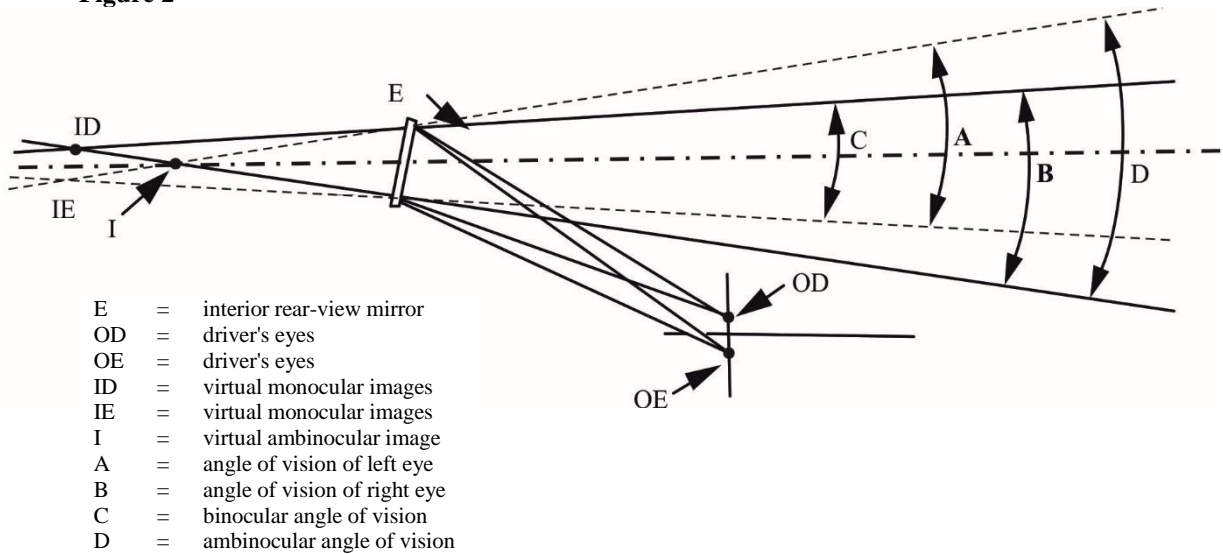

12.3. "Type of vehicle as regards to the driver's awareness of vulnerable road users behind vehicles" means motor vehicles which are identical in respect of the following basic features:

- 12.3.1. Type of **means of rear visibility or detection device for reversing motion**;
- 12.3.2. The bodywork features which reduce the field of vision;
- 12.3.3. The coordinates of point R (where applicable);
- 12.3.4. The prescribed positions, and type-approval markings of compulsory and (if fitted) optional devices for indirect vision.
- 12.4. "Vehicles of categories M_1 , M_2 , M_3 , N_1 , N_2 and N_3 " means those defined in the Consolidated Resolution on the Construction of Vehicles (R.E.3), (document ECE/TRANS/WP.29/78/Rev.6).
- 12.5. "Ocular reference point" means the middle point between the driver's ocular points.
- 12.6. "Backing event" means an amount of time from start and ends of reversing motion as described in 15.1.1. in this Regulation.
- 12.7. "The driver's looking-back ocular points" means two points located at 96 mm longitudinally rearward, 158 mm horizontally inside to vehicle centre direction and 6 mm vertically above from "the driver's ocular points" described in paragraph 12.1.
- 12.8. "Active vehicle mode" means the vehicle mode when:

The powertrain moves the vehicle, on release of the brake system and in some cases by application of pressure to the accelerator pedal (or activation of an equivalent control).
- 12.9. "**Type of means of rear visibility or detection** " means **rear visibility or detection means that do not differ on the following essential characteristics**:

- (a) **The type of devices of means of rear visibility or detection**;
- (b) **The mean of rear visibility or detection**;

13. Application for approval

- 13.1. The application for approval of a vehicle type with regard to the installation of **means of rear visibility or detection** ~~devices for indirect vision~~ shall be submitted by the vehicle manufacturer or by his duly accredited representative.
- 13.2. A model of information document is shown in Annex 2.
- 13.3. A vehicle representative of the vehicle type to be approved shall be submitted to the Technical Service responsible for conducting the approval tests.
- 13.4. The Type Approval Authority shall verify the existence of satisfactory arrangements for ensuring effective checks on conformity of production before type-approval is granted.
- 13.5. The RVCS shall be provided by the applicant with the following documents:
- (a) Technical specification of the RVCS;
 - (b) Operator's manual.

14. Approval

- 14.1. If the vehicle type submitted for approval in accordance with paragraph 13. above meets the requirements of paragraph 15. of this Regulation, approval shall be granted.
- 14.2. An approval number shall be assigned to each type approved. Its first two digits (at present 00) shall indicate the series of amendments incorporating the most recent or technical amendments made to the Regulation at the time of issue of the approval. The same Contracting Party shall not assign the same number to another vehicle type.
- 14.3. Notice of approval or of refusal or of extension or withdrawal of approval of a vehicle type pursuant to this Regulation shall be communicated to the Parties to the Agreement which apply this Regulation by means of a form conforming to the model in Annex 4 to this Regulation.

15. Requirements

15.1. General

For the purpose of this Regulation, the vehicle shall fulfil the following requirements:

During a backing event at least one means of **rear visibility or detection** ~~vision or awareness~~ shall be provided to the driver.

Means of **rear visibility** ~~vision~~ provide a close-proximity rear-view field of vision as defined in paragraph 15.2 below. Possible means are:

- (a) Direct vision,
- (b) Devices approved to UN Regulation No. 46,
- (c) Close Proximity Rear-view Mirror complying with this Regulation,
- (d) Rear-View Camera System complying with this Regulation.

Means of **detection** ~~Awareness~~ provide an information other than vision for field of detection as defined in paragraphs 15.3 below. Possible means are:

- (a) Detection System complying with this Regulation.

- 15.1.1. Backing event starts when the vehicle is in Active vehicle mode and the vehicle's direction selector is placed from forward, park or neutral into reverse

by the driver or a system, and ends when one of the following forward motion conditions, at the manufacturer's choosing, is met:

- (a) A speed ≤ 16 km/h (including 0 km/h), or
- (b) A distance travelled ≤ 10 meters (including 0 meters), or
- (c) A continuous duration ≤ 10 seconds (including 0 seconds), or
- (d) The vehicle's direction selector is not placed in reverse.

15.1.2. The requirements in paragraph 15. shall not apply during a remote control manoeuvring and a remote controlled parking as defined in UN Regulation No. 79.

15.2. Close Proximity Rear-View Field of Vision

The field of vision shall be bounded by the following planes:

- (a) A transverse vertical plane passing through a point 0.3m from the outermost point of the rear of the vehicle;
- (b) A transverse vertical plane passing through a point 3.5m behind the outermost point of the rear of the vehicle;
- (c) Two longitudinal vertical planes parallel to the longitudinal vertical median plane passing through the outermost point of each side of the vehicle.

The height of the field of vision is defined at nine positions within the boundaries of the field of vision with test objects with a height of 0.8m and a diameter of 0.3m which are located on the ground plane as defined in Figure 3 below:

Figure 3
Close-proximity rear-view field of vision

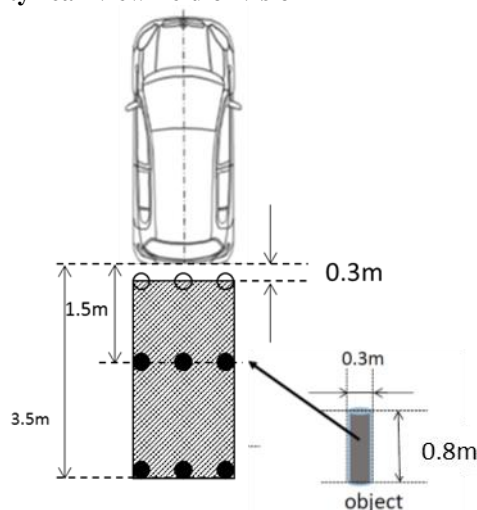

15.2.1. Requirements

When tested under the conditions defined in Annex 9 the requirement for close-proximity rear-view field of vision shall be considered to be satisfied if the defined field of vision can be seen:

- (a) For the test objects in the first row (Test objects A, B, and C):
A 0.15 m x 0.15 m area or the top of the test object shall be visible at least one position on each test object.
- (b) For the test objects in the second row (Test objects D, E, and F) and the third row (Test objects G, H, and I);

The whole test object shall be seen.

- 15.2.1.1. Via the direct view from the driver's looking back ocular points; or
- 15.2.1.2. Via the direct view from the driver's looking back ocular points combined with a close-proximity rear-view mirror installed at the rear end of the vehicle supporting this direct view; or
- 15.2.1.3. Via a device of indirect vision (mirror or CMS or other) approved to UN Regulation No. 46; or
- 15.2.1.4. Via a ~~device of indirect vision~~ **means of rear visibility** (mirror or RVCS or other) complying with this Regulation; or
- 15.2.1.5. Via a device of detection system that complies with this Regulation except for the field of detection (e.g. very short range); or
- 15.2.1.6. Via a combination of devices of paragraphs 15.2.1.3, 15.2.1.4. and 15.2.1.5. except a combination of RVCS and mirror(s) or close-proximity rear-view mirror.
- 15.2.1.7. The options 15.2.1.1 and 15.2.1.2 only apply to the vehicle categories M₁ and N₁, when the distance between looking back ocular point to vehicle rear-end does not exceed 2000 mm and when the vehicle has one seating row.
- 15.2.2. The close-proximity rear-view field of vision shall be established using ambinoocular vision, the eyes being at the "driver's ocular points" as defined in paragraph 12.1. above. The fields of vision shall be determined when the vehicle is in running order as defined in the consolidated Resolution on the Construction of vehicles (R.E.3) (ECE/TRANS/WP.29/78/Rev.6, para. 2.2.5.4.), plus for M1 and N1 vehicles one front seat passenger (75 kg). When established through windows, the glazing shall have a total light transmission factor in accordance with UN Regulation No. 43, Annex 24.

In case of direct view from the driver's looking back ocular points the vertical position of rear seat headrests shall be set at the designed position of assumed to use or the highest position if the headrest has multiple position settings or at the position agreed with the Technical Service.
- 15.2.3. In **the** case of **a** combination of ~~devices~~ **means of rear visibility or detection**, each **entire** transverse row of test objects shall be seen by one ~~device of these means~~. The close-proximity rear-view field of vision shall be obtained from the minimum number of mirrors and monitors.
- 15.2.4. In the case of mirrors consisting of several reflecting surfaces which are either of different curvature or make an angle with each other, at least one of the reflecting surfaces shall provide the field of vision and have the dimensions specified for the class to which they belong.
- 15.3. Field of detection

The field of detection shall be bounded by the following planes (see figure 4):

 - (a) A transverse vertical plane passing through a point 200 mm from the outermost point of the rear of the vehicle;
 - (b) A transverse vertical plane passing through a point 1,000 mm behind the outermost point of the rear of the vehicle;
 - (c) Two longitudinal vertical planes parallel to the longitudinal vertical median plane passing through the outermost point of each side of the vehicle.

Figure 4
Field of detection

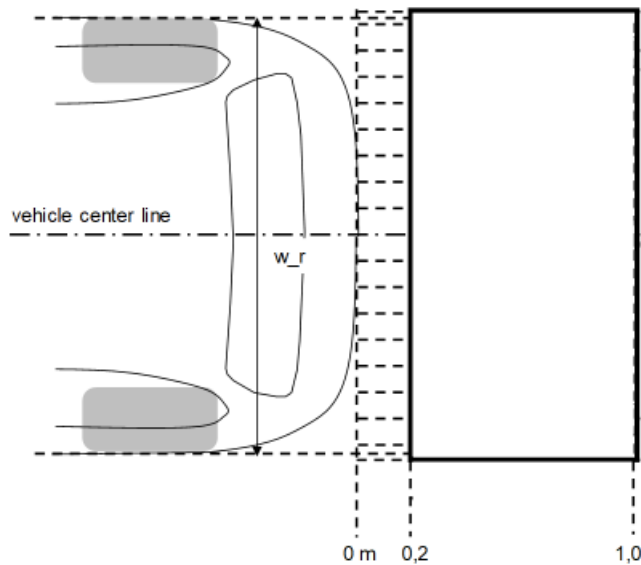

- 15.3.1. When tested under the conditions defined in Annex 10 the requirement for field of detection shall be considered to be satisfied if the information as defined in paragraph 17.2 is provided to the driver.
- 15.4. Devices for reversing motion
- 15.4.1. Position
- 15.4.1.1. Devices for **means of rear visibility or detection indirect vision** shall be so placed that the driver, when sitting on the driving seat in a normal driving position, has a clear view of the road to the rear, side(s) or front of the vehicle.
- 15.4.1.2. In the case of any vehicle, which is in chassis/cab form when the field of vision **or detection** is measured, the minimum and maximum body widths, **heights and lengths** shall be stated by the manufacturer and, if necessary, simulated by dummy headboards. All vehicles and devices for **means of rear visibility or detection indirect vision** configurations taken into consideration during the tests shall be shown on the type-approval certificate for a vehicle with regard to the installation of devices for **means of rear visibility or detection indirect vision** (see Annex 4). **This includes information related to a range of device installation positions (in length, width and height).**
- 15.4.1.3. Devices for **means of rear visibility or detection indirect vision** shall not project beyond the external bodywork of the vehicle substantially more than is necessary to comply with the requirements concerning fields of vision **or fields of detection**.
- 15.4.1.4. Devices for **means of rear visibility or detection indirect vision** shall be fitted in such a way that the devices do not move so as significantly to change the field of vision **or detection** as measured or vibrate to an extent which would cause the driver to misinterpret the nature of the image perceived.

16. Requirements for rear-view camera system

- 16.1. Default view
- In default view the RVCS shall show the field of view at least as defined in paragraph 15.2.

The RVCS must default to the rear-view image at the beginning of each backing event regardless of any modifications to the field of view that the driver has previously selected.

16.1.1. Object size

When the Rear-view image is measured in accordance with the paragraphs 3. of Annex 9, the calculated visual angle subtended by the horizontal width of:

- (a) All three test objects at the last row specified in 15.2 shall average not less than 5 minutes of arc; and
- (b) Each individual test object shall not be less than 3 minutes of arc.

16.1.1.1. Luminance and contrast adjustment

If manual adjustment is provided, the operator's manual shall provide information on how to change the luminance/contrast.

16.1.1.2. Overlay requirements within the required field of vision

Overlays shall display only rearward driving-related visual information or safety-related information. Overlays for other purposes of information in the required field of vision are not allowed.

Manually activated overlays are allowed, only when the driver needs to activate a rearward driving-related function or safety-related function (e.g. cleaning of the lens or activation of trailer hitch view) or requires specific information in such an environment. The driver may have an option to close the overlay.

16.1.1.3. Deactivation

The rear-view image shall remain visible during the backing event until either, the driver modifies the view, or the vehicle direction selector is no longer in the reverse position **or the backing event is finished**.

Modifying the view means to switch to any other camera views.

The view can be manually switched off when the vehicle is not moving rearward.

The system may be switched off when the vehicle detects a coupling by means of a coupling device.

16.1.1.4. Automatic change of view

When there is a risk of collision, the field of view may change and focus on the collision area. It shall be demonstrated to the Technical Service that this change of view increases the safety.

When the vehicle is not driving straight, the field of view may change following the vehicle trajectory.

16.1.2. Operating readiness (System availability)

Non-operation of the system shall be recognizable to the driver (e.g. RVCS failure by, i.e. warning indication, display information, black screen, absence of status indicator). The information for the driver shall be explained in the operator's manual.

16.1.2.1. Response time

The rear-view image meeting the requirements described in 15.2. shall be provided **after within** a maximum of 2.0 seconds after start of the backing event, when tested according to paragraphs 2. of Annex 9.

16.1.3. Monitor inside the vehicle

16.1.3.1. The monitor defined size shall be visible without any obstruction from the ocular reference point. A virtual testing is acceptable.

- 16.1.4. Obstruction of the driver's direct view caused by the installation of a device for indirect vision shall be restricted to a minimum.
- 16.2. Vehicles may be equipped with additional devices for indirect vision.
- 16.3. Notwithstanding the provisions above, any other design concept shall be demonstrated to the satisfaction of the Technical Service within the safety concept that is provided in the provisions above.
- 16.4. The effectiveness of the RVCS shall not be adversely affected by magnetic or electrical fields. This shall be demonstrated by compliance with the technical requirements and transitional provisions of UN Regulation No. 10, 05 series of amendments or any later series of amendments.**

17. Requirements for detection systems

- 17.1. System activation

The system shall be activated when the backing event starts. If proper functioning cannot be effected, either the system shall automatically shut off or the driver shall be able to deactivate the system manually.

The detection system shall remain active as long as **either** the vehicle direction selector is in the reverse position **or the backing event is not ended**.

In case the vehicle can detect coupling with a coupling device, the system may be switched off.
- 17.2. Driver interface and information presentation strategy
 - 17.2.1. The system shall have at least two kinds of information signal selected from audible, optical, and haptics.
 - 17.2.1.1. As long as one information signal remains active, the driver may de-activate the other information signals.
 - 17.2.2. Audible information

When an object is detected in the rear horizontal area as described in paragraph 1.3. of Annex 10. while the reverse gear is selected/engaged, audible information in accordance with ISO 15006:2011 shall be given.

In presenting audible information, the distance **to the target** may be identified **by at** two or more **acoustic levels signals**. These **acoustic signals zones, differentiating differentiated by levels (distances)** and detection widths, may be indicated by changing the frequency of **the** intermittent sound, **and a A** faster intermittent sound or continuous sound shall be used as the distance becomes closer.
 - 17.2.3. Duration of signalling

Signalling for an object shall last as long as the object is detected and shall end when the object is no longer detected or when the system is deactivated.

To reduce the driver's discomfort, the audible signal can be automatically suspended temporarily after a certain time set by the manufacturer has elapsed, provided that the system remains activated. If, while the audible signal is automatically suspended temporarily, the distance to the object becomes shorter, the audible signal shall be automatically resumed. If the distance to the object becomes longer, the audible signal may remain suspended.
 - 17.2.4. Optical information

In the case optical information is placed on a monitor used for other information such as meter cluster display or other displays, overlay is allowed and shall comply with the overlay requirements of the RVCS in 16.1.1.2. of this Regulation.

- 17.2.5. Operating readiness (System availability)
- Non-operation of the system shall be recognizable to the driver (e.g. Detection system failure by, i.e. warning indication, display information, black screen, absence of status indicator). The information for the driver shall be explained in the operator's manual.
- 17.3. Performance of object detection
- 17.3.1. Response time
- At least one of the audible or haptic information signals that meets the requirements as described in 17.2., shall be given to the driver within a maximum of 0.6 seconds after the start of the backing event, when tested according to paragraph 2. of Annex 10.

17.4 The effectiveness of the detection system shall not be adversely affected by magnetic or electrical fields. This shall be demonstrated by compliance with the technical requirements and transitional provisions of UN Regulation No. 10, 05 series of amendments or any later series of amendments.

18. Modifications of the vehicle type and extension of approval

- 18.1. Every modification of the vehicle type shall be notified to the Type Approval Authority which approved the vehicle type. Type Approval Authority shall then either:
- (a) Decide, in consultation with the manufacturer, that a new type approval is to be granted; or
 - (b) Apply the procedure contained in paragraph 18.1.1. (Revision) and, if applicable, the procedure contained in paragraph 18.1.2. (Extension).
- 18.1.1. Revision
- When particulars recorded in the information folder have changed and the Type Approval Authority considers that the modifications made are unlikely to have an appreciable adverse effect, and that in any case the vehicle still complies with the requirements, the modification shall be designated a "revision".
- In such a case, the Type Approval Authority shall issue the revised pages of the information folder as necessary, marking each revised page to show clearly the nature of the modification and the date of re-issue. A consolidated, updated version of the information folder, accompanied by a detailed description of the modification, shall be deemed to meet this requirement.
- 18.1.2. Extension
- The modification shall be designated an "extension" if, in addition to the change of the particulars recorded in the information folder,
- (a) Further inspections or tests are required; or
 - (b) Any information on the communication document (with the exception of its attachments) has changed; or
 - (c) Approval to a later series of amendments is requested after its entry into force.
- 18.2. Confirmation or refusal of approval, specifying the alterations, shall be communicated to the Parties to the Agreement which apply this Regulation by means of a form conforming to the model in Annex 4 to this Regulation. In addition, the index to the information package, attached to the communication

document, shall be amended accordingly to show the date of the most recent revision or extension.

- 18.3. The Type Approval Authority issuing the extension of approval shall assign a series number to each communication form drawn up for such an extension.

19. Conformity of production

- 19.1. The conformity of production procedure shall comply with those set out in the Agreement, Schedule 1 (E/ECE/TRANS/505/Rev.3).

- 19.2. Every vehicle approved under this Regulation shall be so manufactured as to conform to the type approved by meeting the requirements set out in paragraph 15., where applicable paragraph 16. and paragraph 17. above.

20. Penalties for non-conformity of production

- 20.1. The approval granted in respect of a vehicle type pursuant to this Regulation may be withdrawn if the requirement laid down in paragraph 19.1. above is not complied with or if the vehicle fails to pass the checks prescribed in paragraph 19.2. above.

- 20.2. If a Party to the Agreement which applies this Regulation withdraws an approval it has previously granted, it shall forthwith so notify the other Contracting Parties applying this Regulation by means of a copy of the approval form bearing at the end, in large letters, the signed and dated annotation "APPROVAL WITHDRAWN".

21. Production definitively discontinued

If the holder of the approval completely ceases to manufacture a type of vehicle approved in accordance with this Regulation, he shall so inform the Type Approval Authority which granted the approval. Upon receiving the relevant communication, the Authority shall inform thereof the other Parties to the Agreement applying this Regulation by means of a copy of the approval form bearing at the end, in large letters, the signed and dated annotation "PRODUCTION DISCONTINUED".

22. Names and addresses of Technical Services responsible for conducting approval tests, and of Type Approval Authorities

The Parties to the Agreement applying this Regulation shall communicate to the United Nations Secretariat the names and addresses of the Technical Services responsible for conducting approval tests and of the Type Approval Authorities which grant approval and to which forms certifying approval or refusal or extension or withdrawal of approval, issued in other countries, are to be sent.

Annex 1

Information document for type approval of a device for means of rear visibility reversing motion

The following information, if applicable, shall be supplied in triplicate and shall include a list of contents.

Any drawings shall be supplied in appropriate scale and in sufficient detail on size A4 paper or on a folder of A4 format.

Photographs, if any, shall show sufficient details.

1. Make (trade name of manufacturer):
2. Type and general commercial description(s):
3. Means of identification of the type, if indicated on the device:
4. Category of vehicle for which the device is intended:
5. Name and address of manufacturer:
6. Location and method of affixing of the approval mark **for close-proximity rear-view mirrors**:
- 6.1. Other mean of identification link to the approval **mark for close-proximity rear-view mirrors**:
7. Address(es) of assembly plant(s):
8. Mirrors (state for each mirror):
- 8.1. Variant
- 8.2. Drawing(s) for the identification of the mirror:
- 8.3. Details of the method of attachment:
- ~~9. Devices for indirect vision other than mirrors:~~
- ~~9.1. Type and characteristics (such as a complete description of the device):~~
- ~~9.2. Sufficiently detailed drawings to identify the complete device including installation instructions; the position for the type approval mark has to be indicated on the drawings:~~

Annex 2 Information document for type approval of a vehicle with respect to the installation of means of rear visibility or ~~detection devices for reversing motion~~

The following information, if applicable, shall be supplied in triplicate and include a list of contents.

Any drawings shall be supplied in appropriate scale and in sufficient detail on size A4 paper or on a folder of A4 format.

Photographs, if any, shall show sufficient details.

General

1. Make (trade name of manufacturer):
2. Type and general commercial description(s):
3. Means of identification of type, if marked on the vehicle:
4. Location of that marking:
5. Category of vehicle:.....
6. Name and address of manufacturer:
7. Address(es) of assembly plant(s):.....

General construction characteristics of the vehicle

8. Photograph(s) and/or drawing(s) of a representative vehicle:
9. Driving position: left/right¹
- 9.1. The vehicle is equipped to be driven in right-hand/left hand traffic¹.....
10. Range of vehicle dimensions (overall):
- 10.1 For chassis without bodywork
- 10.1.1. Width:²
- 10.1.1.1. Maximum permissible width:
- 10.1.1.2. Minimum permissible width:
- 10.1.2. Length:**
- 10.1.2.1. Maximum permissible length:**
- 10.1.2.2. Minimum permissible length:**
- 10.1.3. Height:**

¹ Strike out what does not apply.

² "Overall width" of a vehicle means a dimension which is measured according to ISO standard 612-1978, term No. 6.2. In the case of vehicles of category other than M₁, in addition to the provisions of that standard, when measuring the vehicle width the following devices shall not be taken into account:

- (a) Customs sealing devices and their protection;
- (b) Devices for securing the tarpaulin and their protection;
- (c) Tyre failure tell-tale devices;
- (d) Protruding flexible parts of a spray-suppression system;
- (e) Lighting equipment;
- (f) For buses, access ramps in running order, lifting platforms and similar equipment in running order provided that they do not exceed 10 mm from the side of the vehicle and the corners of the ramps facing forwards or rearwards are rounded to a radius of not less than 5 mm; the edges shall be rounded to a radius of not less than 2.5 mm;
- (g) Devices for indirect vision;
- (h) Tyre-pressure indicators;
- (i) Retractable steps;
- (j) The deflected part of the tyre walls immediately above the point of contact with the ground.

- 10.1.3.1. Maximum permissible height:**
- 10.1.3.2. Minimum permissible height:**
- 10.2. For chassis with bodywork:
- 10.2.1. Width²
- 10.2.2. Length**
- 10.2.3. Height**
11. Bodywork
- 11.1. ~~Means of rear visibility or detection Devices for indirect vision:~~ **Direct vision, Devices approved to UN Regulation No. 46, Close Proximity Rear-view Mirror complying with this Regulation, Rear-View Camera System complying with this Regulation, Detection System complying with this Regulation³.**
- 11.1.1. Direct vision,**
- 11.1.1.1. Drawing(s)/photograph(s) showing the direct vision relative to the vehicle structure:**
- 11.1.2. Devices approved to UN Regulation No. 46,**
- 11.1.2.1. Type approval number(s) of the device(s) approved according UN Regulation No. 46**
- 11.1.2.2. Class(es) of mirrors and devices for indirect vision (I, II, III, IV, V, VI)²**
- 11.1.2.3. Drawing(s) showing the position(s) of the device(s) relative to the vehicle structure:**
- 11.1.3. Close Proximity Rear-view Mirror complying with this Regulation,**
- 11.1.3.1. Drawing(s) showing the position(s) of the mirror relative to the vehicle structure:**
- 11.1.3.2. Details of the method(s) of attachment including that part of the vehicle structure to which it is attached:**
- 11.1.3.3. Optional equipment which may affect the rearward field of vision:**
- 11.1.3.4. A brief description of the electronic components (if any) of the adjustment device:**
- 11.1.4. Rear-View Camera System complying with this Regulation.**
- 11.1.4.1. Drawing(s)/photograph(s) showing the position(s) of the camera(s) relative to the vehicle structure:**

² "Overall width" of a vehicle means a dimension which is measured according to ISO standard 612-1978, term No. 6.2. In the case of vehicles of category other than M₁, in addition to the provisions of that standard, when measuring the vehicle width the following devices shall not be taken into account:

- (a) Customs sealing devices and their protection;
- (b) Devices for securing the tarpaulin and their protection;
- (c) Tyre failure tell-tale devices;
- (d) Protruding flexible parts of a spray-suppression system;
- (e) Lighting equipment;
- (f) For buses, access ramps in running order, lifting platforms and similar equipment in running order provided that they do not exceed 10 mm from the side of the vehicle and the corners of the ramps facing forwards or rearwards are rounded to a radius of not less than 5 mm; the edges shall be rounded to a radius of not less than 2.5 mm;
- (g) Devices for indirect vision;
- (h) Tyre-pressure indicators;
- (i) Retractable steps;
- (j) The deflected part of the tyre walls immediately above the point of contact with the ground.

³ Strike out what does not apply.

- 11.1.4.2. Drawing(s)/photograph(s) showing the arrangement of the monitor(s) including surrounding interior parts:
- 11.1.4.3. Drawing(s)/photograph(s) showing the drivers view onto the monitor(s):
- 11.1.4.4. Drawing(s)/photograph(s) showing the setup and monitor image of the required field of view:
- 11.1.4.5. Details of the method(s) of attachment of the Rear-View Camera System including that part of the vehicle structure to which it is attached:
- 11.1.4.6. Optional equipment which may affect the rearward field of vision:
- 11.1.4.7. A brief description of the electronic components (if any) of the adjustment device:
- 11.1.4.8. A technical specification and operator's manual of the Rear-View Camera System:
- 11.1.5. Detection System complying with this Regulation.
- 11.1.5.1. Drawing(s)/photograph(s) showing the position(s) of the sensor(s) relative to the vehicle structure:
- 11.1.5.2. Information signal: audible, optical, haptics⁴.
- 11.1.5.3. A technical specification and operator's manual of the detection System:
- ~~11.1.1. Mirrors~~
- ~~11.1.1.1. Drawing(s) showing the position of the mirror relative to the vehicle structure: .~~
- ~~11.1.1.2. Details of the method of attachment including that part of the vehicle structure to which it is attached:~~
- ~~11.1.1.3. Optional equipment which may affect the rearward field of vision:~~
- ~~11.1.1.4. A brief description of the electronic components (if any) of the adjustment device:~~
- ~~11.1.2. Devices for indirect vision other than mirrors:~~
- ~~11.1.2.1. Sufficiently detailed drawings with the installation instructions:~~
- ~~11.1.2.2. In the case of Rear View Camera System:~~
- ~~11.1.2.2.1. Drawing(s)/photograph(s) showing the position of the camera(s) relative to the vehicle structure:~~
- ~~11.1.2.2.2. Drawing(s)/photograph(s) showing the arrangement of the monitor(s) including surrounding interior parts:~~
- ~~11.1.2.2.3. Drawing(s)/photograph(s) showing the drivers view onto the monitor(s):~~
- ~~11.1.2.2.4. Drawing(s)/photograph(s) showing the setup and monitor image of the required field of view:~~
- ~~11.1.2.2.5. Details of the method of attachment of the Rear View Camera System including that part of the vehicle structure to which it is attached:~~
- ~~11.1.2.2.6. Optional equipment which may affect the rearward field of vision:~~
- ~~11.1.2.2.7. A brief description of the electronic components (if any) of the adjustment device:~~
- ~~11.1.2.2.8. A technical specification and operator's manual of the Rear View Camera System:~~

⁴ Strike out what does not apply.

Annex 3

Communication

(Maximum format: A4 (210 x 297 mm))



issued by:

Name of administration:

.....

Concerning:² Approval granted
 Approval extended
 Approval refused
 Approval withdrawn
 Production definitively discontinued

of a type of device for **(Separate Technical Unit) for means of rear visibility reversing motion** pursuant to UN Regulation No. [158]

Approval No. Extension No.

1. Trade name or mark of device:
2. Manufacturer's name for the type of device:
3. Manufacturer's name and address:
4. If applicable, name and address of manufacturer's representative:
5. Submitted for approval on:
6. Technical Service responsible for conducting approval tests:
7. Date of report issued by that Service
8. Number of report issued by that Service
9. Brief description
- Identification of the device: mirror, Rear-View Camera System, other device²
- Device for close-proximity rear-view²
10. Position of the approval mark:
11. Reason(s) for extension (if applicable):
12. Approval granted/refused/extended/withdrawn:²
13. Place:
14. Date:
15. Signature:
16. The list of documents deposited with the Type Approval Authority which has granted approval is annexed to this communication and may be obtained on request.

¹ Distinguishing number of the country which has granted/extended/refused/withdrawn approval (see approval provisions in the Regulations).

² Strike out what does not apply.

Annex 4

Communication

(Maximum format: A4 (210 x 297 mm))



issued by :

Name of administration:

.....

- Concerning: ²
- Approval granted
 - Approval extended
 - Approval refused
 - Approval withdrawn
 - Production definitively discontinued

of a type of vehicle with regard to the ~~mounting of means of rear visibility or detection devices for reversing motion~~ pursuant to UN Regulation No. [XXX]

Approval number: Extension No.:

1. Make (trade name of manufacturer):
2. Type and general commercial description(s)
3. Means of identification of type, if marked on the vehicle:.....
- 3.1. Location of that marking:.....
4. Category of vehicle: (M₁, M₂, M₃, N₁, N₂, N₃)²
5. Name and address of manufacturer:.....
6. Address(es) of the production plant(s)
7. Additional information: (where applicable). See appendix
8. Technical Service responsible for carrying out the tests:
9. Date of test report:
10. Number of test report:
11. Remarks: (if any). See appendix
12. Place:.....
13. Date:.....
14. Signature:
15. The index to the information package lodged with the Type Approval Authority, which may be obtained on request is attached.

¹ Distinguishing number of the country which has granted/extended/refused/withdrawn approval (see approval provisions in this Regulation)

² Strike out what does not apply.

Annex 4 – Appendix

Appendix to type approval communication form No. concerning the type approval of a vehicle with regard to the ~~mounting of means of rear visibility or detection devices for reversing motion~~ under UN Regulation No. [158].

1. Trade name or mark of **means of rear visibility or detection** ~~mirrors and supplementary devices for indirect vision~~ and component type-approval number (if applicable):
2. **Means of rear visibility or detection: Direct vision, Devices approved to UN Regulation No. 46, Close Proximity Rear-view Mirror complying with this Regulation, Rear-View Camera System complying with this Regulation, Detection System complying with this Regulation¹²** ~~Close proximity rear view mirrors and devices for reversing motion.~~
3. Extension of type approval of the vehicle to cover the following **means of rear visibility or detection** ~~device for indirect vision~~
4. Data for identification of the R point of the driver's seating position:
5. Maximum and minimum bodywork width, **length and height** in respect of which the ~~mirror and the devices for indirect vision~~ **has means of rear visibility or detection have** been granted type-approval
6. The following documents, bearing the type approval number shown above, are annexed to this certificate (if applicable):
 - (a) Drawings showing the mounting(s) of the devices for **means of rear visibility or detection** ~~indirect vision~~
 - (b) Drawings and plans showing the mounting position(s) and characteristics of the part of the structure where the devices for **means of rear visibility or detection** ~~indirect vision~~ are mounted.
 - (c) **Drawings and plans showing the visual obstructions which affect the rear visibility, e.g. the interior fittings, glazing, etc.**
7. Remarks: (e.g. valid for right hand/left hand traffic¹)

¹² Strike out what does not apply.

Annex 5

Arrangement of approval mark of a device for **means of rear visibility indirect vision**

(See paragraph 5.4. of the Regulation)

$a = 5$ millimetre min.

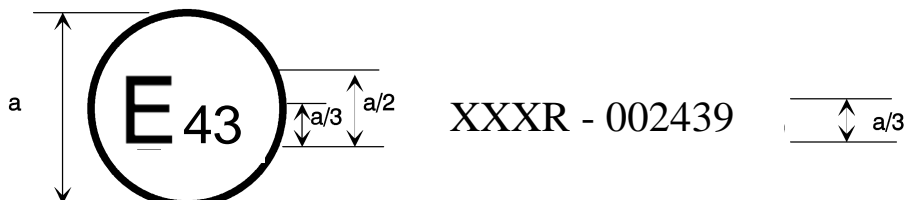

The above approval mark affixed to a device for **means of rear visibility indirect vision** indicates that the device is a main Close-proximity rear-view device, which has been approved in Japan (E 43) pursuant to UN Regulation No. [XXX] and under approval number 002439. The first two digits of the approval number indicate that the approval was granted in accordance with the requirements of UN Regulation No. [XXX] in its original form.

Note: The approval number and the additional symbol shall be placed close to the circle and either above or below the "E" or to the left or right of that letter. The digits of the approval number shall be on the same side of the "E" and point in the same direction. The additional symbol shall be directly opposite the approval number. The use of Roman numerals as approval numbers shall be avoided so as to prevent any confusion with other symbols.

Annex 6

Test method for determining reflectivity

1. Definitions
 - 1.1. CIE standard illuminate A:¹ Colorimetric illuminate, respecting the full radiator at $T_{68} = 2,855.6$ K.
 - 1.1.2. CIE standard source A¹: Gas-filled tungsten filament lamp operating at a correlated colour temperature of $T_{68} = 2,855.6$ K.
 - 1.1.3. CIE 1931 standard colorimetric observer¹: Receptor of radiation whose colorimetric characteristics correspond to the spectral tristimulus values $\bar{x}(\lambda)$, $\bar{y}(\lambda)$, $\bar{z}(\lambda)$ (see table).
 - 1.1.4. CIE spectral tristimulus values¹: Tristimulus values of the spectral components of an equi energy spectrum in the CIE (XYZ) system.
 - 1.1.5. Photopic vision:¹ Vision by the normal eye when it is adapted to levels of luminance of at least several cd/m^2 .
 2. Apparatus
 - 2.1. General

The apparatus shall consist of a light source, a holder for the test sample, a receiver unit with a photodetector and an indicating meter (see Figure 1), and means of eliminating the effects of extraneous light.

The receiver may incorporate a light-integrating sphere to facilitate measuring the reflectance of non-flat (convex) mirrors (see Figure 2).
 - 2.2. Spectral characteristics of light source and receiver

The light source shall consist of a CIE standard source A and associated optics to provide a near-collimated light beam. A voltage stabiliser is recommended in order to maintain a fixed lamp voltage during instrument operation.

The receiver shall have a photodetector with a spectral response proportional to the photopic luminosity function of the CIE (1931) standard colorimetric observer (see table). Any other combination of illuminate-filter-receptor giving the overall equivalent of CIE standard illuminate A and photopic vision may be used. When an integrating sphere is used in the receiver, the interior surface of the sphere shall be coated with a matt (diffusive) spectrally non-selective white coating.
 - 2.3. Geometrical conditions

The angle of the incident beam (Θ) should preferably be 0.44 ± 0.09 rad ($25 \pm 5^\circ$) from the perpendicular to the test surface and shall not exceed the upper limit of the tolerance (i.e. 0.53 rad or 30°). The axis of the receptor shall make an angle (Θ) with this perpendicular equal to that of the incident beam (see Figure 1). The incident beam upon arrival at the test surface shall have a diameter of not less than 13 mm (0.5 inch). The reflected beam shall not be wider than the sensitive area of the photodetector, shall not cover less than 50 per cent of such area, and as nearly as possible shall cover the same area segment as used during instrument calibration.

When an integrating sphere is used in the receiver section, the sphere shall have a minimum diameter of 127 mm (5 inch). The sample and incident beam

¹ Definitions taken from CIE publication 50 (45), International Electrotechnical Vocabulary, Group 45, Lighting

apertures in the sphere wall shall be of such a size as to admit the entire incident and reflected light beams. The photodetector shall be so located as not to receive direct light from either the incident or the reflected beam.

2.4. Electrical characteristics of the photodetector-indicator unit

The photodetector output as read on the indicating meter shall be a linear function of the light intensity of the photosensitive area. Means (electrical and/or optical) shall be provided to facilitate zeroing and calibration adjustments. Such means shall not affect the linearity or the spectral characteristics of the instrument. The accuracy of the receptor indicator unit shall be within ± 2 per cent of full scale, or ± 10 per cent of the magnitude of the reading, whichever is the smaller.

2.5. Sample holder

The mechanism shall be capable of locating the test sample so that the axes of the source arm and receptor intersect at the reflecting surface. The reflecting surface may lie within or at either face of the mirror sample, depending on whether it is a first surface, second surface or prismatic "flip" type mirror.

3. Procedure

3.1. Direct calibration method

In the direct calibration method, air is used as the reference standard. This method is applicable for those instruments, which are so constructed as to permit calibration at the 100 per cent point by swinging the receiver to a position directly on the axis of the light source (see Figure 1).

It may be desired in some cases (such as when measuring low-reflectivity surfaces) to use an intermediate calibration point (between 0 and 100 per cent on the scale) with this method. In these cases, a neutral density filter of known transmittance shall be inserted in the optical path, and the calibration control shall then be adjusted until the meter reads the percentage transmission of the neutral density filter. This filter shall be removed before reflectivity measurements are performed.

3.2. Indirect calibration method

The indirect calibration method is applicable in the case of instruments with fixed source and receiver geometry. A properly calibrated and maintained reflectance standard is required. This reference standard should preferably be a flat mirror with a reflectance value as near as possible to that of the test samples.

3.3. Flat mirror measurement

The reflectance of flat mirror samples can be measured on instruments employing either the direct or the indirect calibration method. The reflectance value is read directly from the indicating meter.

3.4. Non-flat (convex) mirror measurement

Measurement of the reflectance of non-flat (convex) mirrors requires the use of instruments which incorporate an integrating sphere in the receiver unit (see Figure 2). If the instrument-indicating meter indicates n_e divisions with a standard mirror of E per cent reflectance, then, with a mirror of unknown reflectance, n_x divisions will correspond to a reflectance of X per cent, in accordance with the formula:

$$X = E \frac{n_x}{n_e}$$

Figure 1
Generalised reflectometer showing experimental set-ups for the two calibration methods

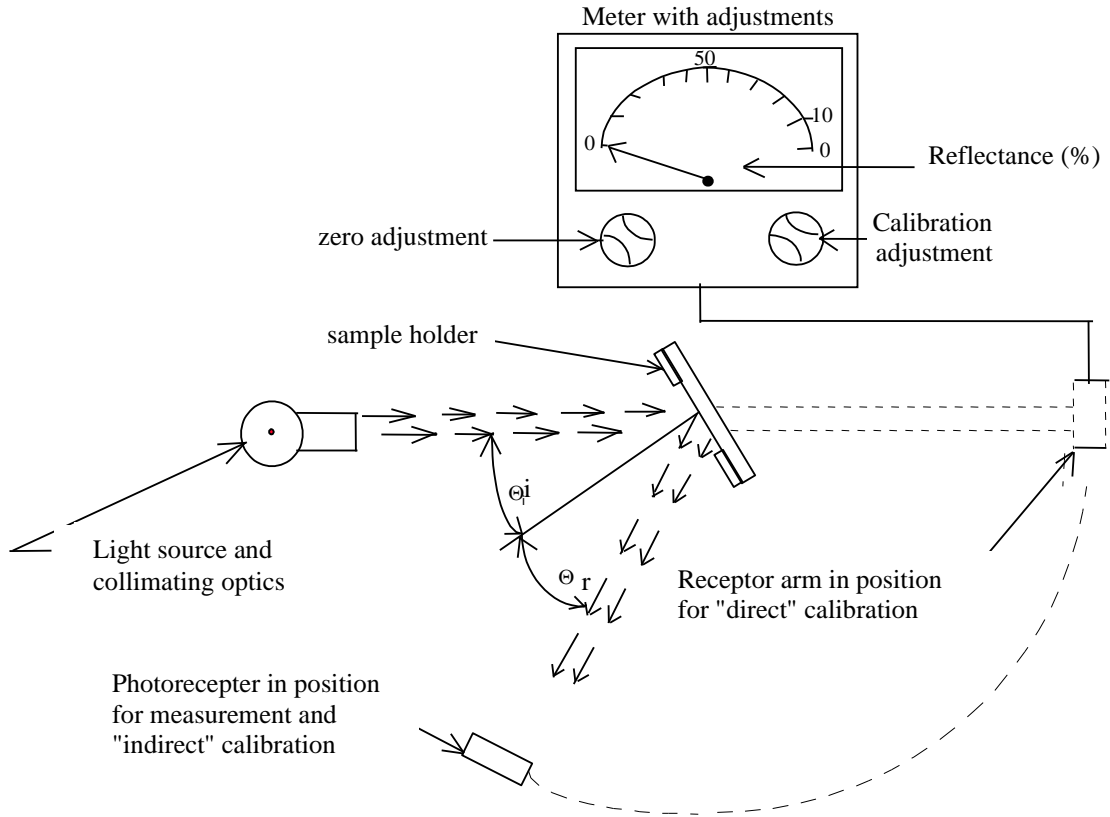
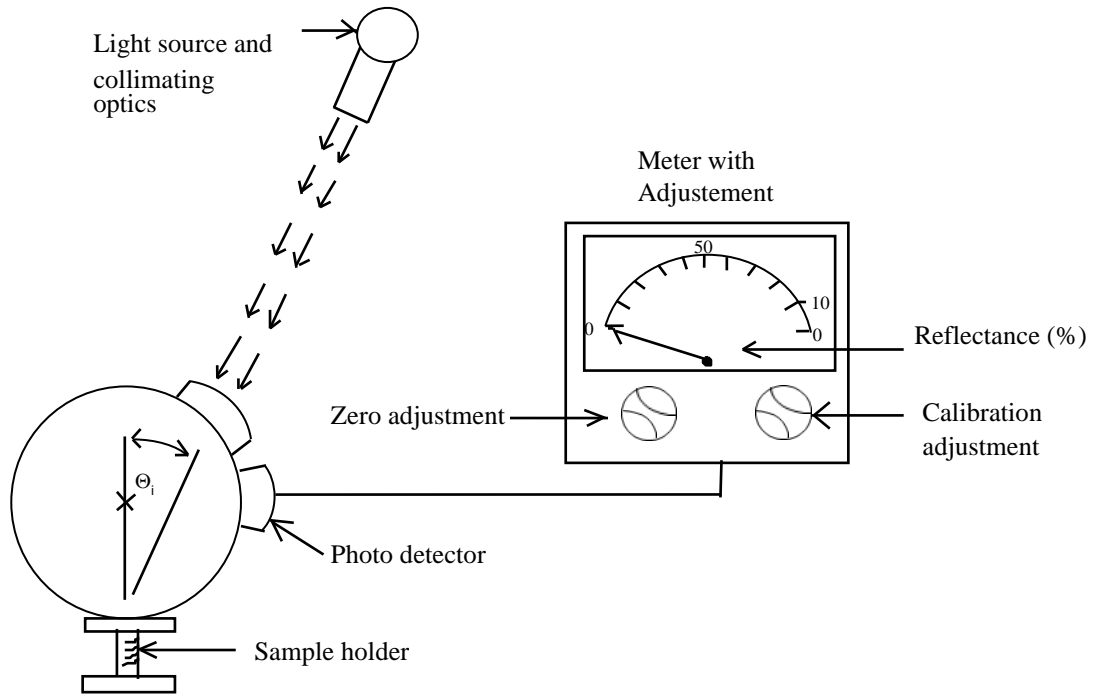

Figure 2
Generalised reflectometer, incorporating an integrating sphere in the receiver



4. Spectral tristimulus values for the CIE 1931 standard colorimetric observer²
This table is taken from CIE publication 50 (45) (1970)

λ nm	$\bar{x}(\lambda)$	$\bar{y}(\lambda)$	$\bar{z}(\lambda)$
380	0.001 4	0.000 0	0.006 5
390	0.004 2	0.000 1	0.020 1
400	0.014 3	0.000 4	0.067 9
410	0.043 5	0.001 2	0.207 4
420	0.134 4	0.004 0	0.645 6
430	0.283 9	0.011 6	1.385 6
440	0.348 3	0.023 0	1.747 1
450	0.336 2	0.038 0	1.772 1
460	0.290 8	0,060 0	1.669 2
470	0.195 4	0.091 0	1.287 6
480	0.095 6	0.139 0	0.813 0
490	0.032 0	0.208 0	0.465 2
500	0.004 9	0.323 0	0.272 0
510	0.009 3	0.503 0	0.158 2
520	0.063 3	0.710 0	0.078 2
530	0.165 5	0.862 0	0.042 2
540	0.290 4	0.954 0	0.020 3
550	0.433 4	0.995 0	0.008 7
560	0.594 5	0.995 0	0.003 9
570	0.762 1	0.952 0	0.002 1
580	0,916 3	0.870 0	0.001 7
590	1.026 3	0.757 0	0.001 1
600	1.062 2	0.631 0	0.000 8
610	1.002 6	0.503 0	0.000 3
620	0.854,4	0.381 0	0.000 2
630	0.642 4	0.265 0	0.000 0
640	0.447 9	0.175 0	0.000 0
650	0.283 5	0,107 0	0.000 0
660	0.164 9	0.061 0	0.000 0
670	0.087 4	0,032 0	0.000 0
680	0.046 8	0.017 0	0.000 0
690	0.22 7	0,008 2	0.000 0
700	0.011 4	0.004 1	0.000 0
710	0.005 8	0.002 1	0.000 0
720	0.02 9	0.001 0	0.000 0
730	0.001 4	0.000 5	0.000 0
740	0.000 7	0.000 2 (*)	0.000 0
750	0.000 3	0.000 1	0.000 0
760	0.000 2	0.000 1	0.000 0
770	0.000 1	0.000 0	0.000 0
780	0.000 0	0.000 0	0.000 0

(*) Changed in 1966 (from 3 to 2)

² Abridged table. The values of $\bar{y}(\lambda) = V(\lambda)$ are rounded off to four decimal places

Explanatory figure

Example of device for measuring the reflection factor of spherical mirrors

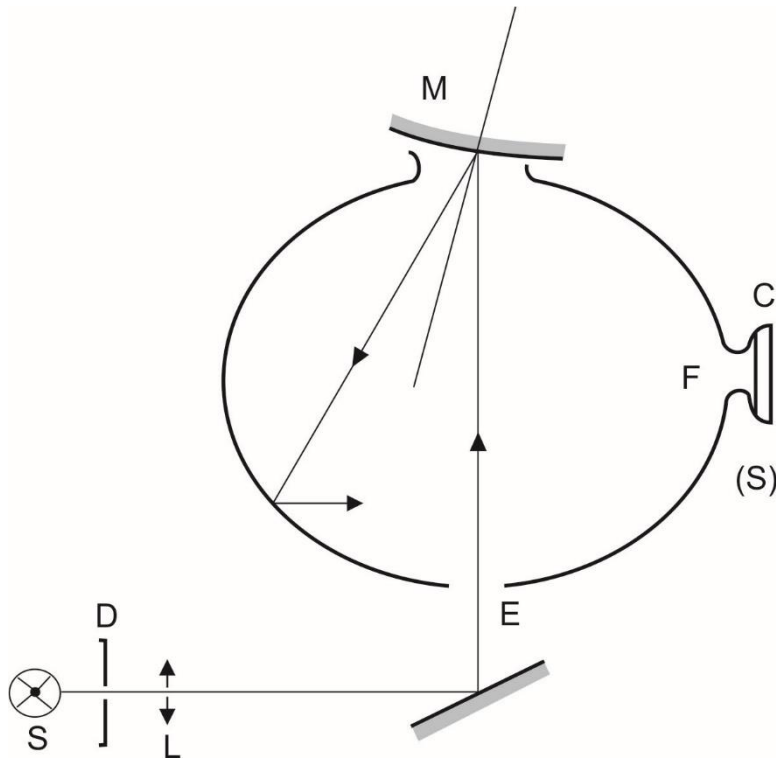

- | | | |
|-----|---|-----------------------|
| C | = | Receiver |
| D | = | Diaphragm |
| E | = | Window of entry |
| F | = | Window of measurement |
| L | = | Lens |
| M | = | Object window |
| S | = | Light source |
| (S) | = | Integrating sphere |

Annex 7

Procedure for determining the radius of curvature "r" of the reflecting surface of a mirror

1. Measurement
 - 1.1. Equipment

A "spherometer" similar to the one described in Figure 1 of this annex having the indicated distances between the tracing pin of the dial gauge and the fixed legs of the bar is used.
 - 1.2. Measuring points
 - 1.2.1. The principal radii of curvature shall be measured at three points situated as close as possible to positions at one-third, one-half and two-thirds of the distance along the arc of the reflecting surface passing through the centre of this surface and parallel to segment b, or of the arc passing through the centre of the reflecting surface which is perpendicular to it if this arc is the longer.
 - 1.2.2. Where, owing to the size of the reflecting surface, it is impossible to obtain measurements in the directions defined in paragraph 2.1.2.2.2. of this Regulation, the Technical Services responsible for the tests may take measurements at the said point in two perpendicular directions as close as possible to those prescribed above.
2. Calculation of the radius of curvature "r"

"r" expressed in mm is calculated from the formula:

$$r = \frac{r_p1 + r_p2 + r_p3}{3}$$

Where:

- r_p1 = the radius of curvature at the first measuring point,
 r_p2 = the radius of curvature at the second measuring point,
 r_p3 = the radius of curvature at the third measuring point.

Annex 8

Procedure for determining the "H" point and the actual torso angle for seating positions in motor vehicles¹

Appendix 1 - Description of the three dimensional "H" point machine (3-D H machine)¹

Appendix 2 - Three-dimensional reference system¹

Appendix 3 - Reference data concerning seating positions¹

¹ The procedure is described in Annex 1 to the Consolidated Resolution on the Construction of Vehicles (R.E.3) (document ECE/TRANS/WP.29/78/Rev.6).
www.unece.org/trans/main/wp29/wp29wgs/wp29gen/wp29resolutions.html

Annex 9

Test methods for close-proximity rear-view field of vision

1. Field of vision

The requirements of field of vision defined in paragraphs 15.2. of this Regulation can be tested under the conditions described in this Annex.

1.1. Test objects

Each test object shall be a right circular cylinder that is 0.8 m high and 0.3 m in external diameter. Each test object shall be marked as follows.

- (a) The test object shall have a painted patch measuring 0.15 m x 0.15 m that can be moved from the bottom to the top of the side of the cylinder.
- (b) The painted patch shall be of a colour that contrasts with both the rest of the cylinder and the test surface.

Figure A
Test object

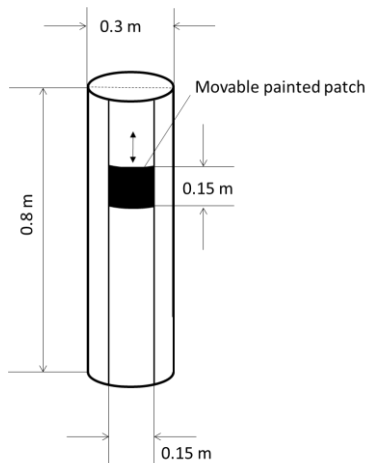

1.2. Test object locations and orientations

Place the test objects at the locations specified in (a) to (h) and illustrated in Figure B. Measure the distances shown in Figure B from a test object to another test object or other object from the cylindrical centre (axis) of the test object as viewed from above. Each test object shall be oriented so that its axis is vertical.

- (a) Place test objects A, B, and C so that their centres are in a transverse vertical plane that is 0.3 m to the rear of a transverse vertical plane tangential to the rearmost surface of the vehicle.
- (b) Place test object B so that its centre is in a longitudinal vertical plane passing through the vehicle's longitudinal centreline.
- (c) Place test objects D, E, and F so that their centres are in a transverse vertical plane that is 1.5 m to the rear of a transverse vertical plane tangential to the rearmost surface of the vehicle.
- (d) Place test object E so that its centre is in a longitudinal vertical plane passing through the vehicle's longitudinal centreline.
- (e) Place test objects G, H, and I so that their centres are in a transverse vertical plane that is 3.35 m to the rear of a transverse vertical plane tangential to the rearmost surface of the vehicle.
- (f) Place test object H so that its centre is in a longitudinal vertical plane passing through the vehicle's longitudinal centreline.

- (g) Place test objects A, D, and G so that their outermost are in a longitudinal vertical plane tangential to the left-side outermost surface of the vehicle.
- (h) Place test objects C, F, and I so that their outermost are in a longitudinal vertical plane tangential to the right-side outermost surface of the vehicle.

Mechanical coupling devices and luggage racks located on the rear of the vehicle shall be disregarded.

Figure B
Test object locations

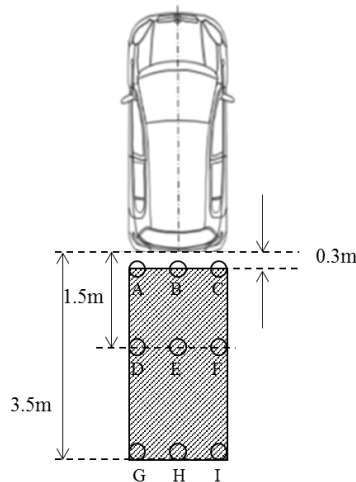

1.3 Test conditions

1.3.1. Lighting.

The ambient illumination conditions in which testing is conducted consists of light that is evenly distributed from above and is at an intensity of between 7,000 lux and 10,000 lux, as measured at the centre of the exterior surface of the vehicle's roof.

1.3.2. Temperature.

The temperature inside the vehicle during test is any temperature between 15 °C and 25 °C,

1.3.3. Vehicle conditions.

1.3.3.1 Tires.

The vehicle's tires are set to the vehicle manufacturer's recommended cold inflation pressure.

1.3.3.2. Vehicle load.

The vehicle is in running order as defined in the consolidated Resolution on the Construction of vehicles (R.E.3) (ECE/TRANS/WP.29/78/Rev.6, paragraph 2.2.5.4.), **plus for M1 and N1 vehicles one front seat passenger (75 kg).**

1.3.3.3. Adjustable suspension

If the vehicle is equipped with adjustable suspension system, it shall be set at worst condition.

1.3.3.4. Rear hatch and trunk lids.

If the vehicle is equipped with rear hatches or trunk lids, they are closed and latched in their normal vehicle operating condition.

1.4. Test procedure

The visibility of each pole shall be tested one by one.

Optionally, one row can be tested at the same time. After successful pole identification, the pole can be removed.

The poles of the first row (A, B, C) may rotate direction in order to be visible the painted patch as much as possible.

2. System readiness

2.1. Test conditions

- (a) The vehicle shall be left in a parked parking status until it is ensured that all electronic systems are de-activated; or for a minimum of 30 minutes.
- (b) It is permissible for the test person or equipment to be already situated within the vehicle.
- (c) Ensure the vehicle gear selector is **not in reverse gear** ~~in neutral or forward gear~~.
- (d) The test may start with opening the driver door. Once the door is opened, it shall be closed again.

2.2. Test procedure

- (a) Put the vehicle into the active vehicle mode. This action shall initiate/start the first timer.
- (b) Wait for a minimum of 6 sec
- (c) Start the backing event by selecting the reverse mode. If it is not possible to put the vehicle into reversing mode 6 sec after being put into active vehicle mode, the backing event shall be started as soon as technically possible.
- (d) Initiate/start the second timer, in accordance with the manufacturer's specification and no later than when the reverse mode or gear is engaged.
- (e) Record the response time on second timer until the rear-view is completely visible on the display.

3. Object size

3.1. Test reference point.

Obtain the test reference point using the following procedure.

- (a) Locate the centre of the forward-looking eye midpoint (Mf) illustrated in Figure C so that it is 635 mm vertically above the H point (H) and 96 mm aft of the H point.
- (b) Locate the head/neck joint centre (J) illustrated in Figure C so that it is 100 mm rearward of Mf and 588 mm vertically above the H point. In the case of the head/neck joint centre (J) is not compatible for the vehicle seat configuration, adjust the driver's seat to the midpoint of the longitudinal adjustment range. If the seat cannot be adjusted to the midpoint of the longitudinal adjustment range, the closest adjustment position to the rear of the midpoint shall be used.
- (c) Draw an imaginary horizontal line between Mf and a point vertically above J, defined as J2.
- (d) Rotate the imaginary line about J2 in the direction of the rear-view image until the straight-line distance between Mf and the centre of the display used to present the rear-view image required in this standard reaches the shortest possible value.
- (e) Define this new, rotated location of Mf to be Mr (eye midpoint rotated).

3.1. Measurement procedure.

- (a) Locate a 35 mm or larger format still camera, video camera, or digital equivalent such that the centre of the camera's image plane is located at M_r and the camera lens is directed at the centre of the display's rear-view image.
- (b) Affix a ruler at the base of the rear-view image in an orientation perpendicular with a test object cylinder centreline. If the vehicle head restraints obstruct the camera's view of the display, they may be adjusted or removed.
- (c) Photograph the image of the visual display with the ruler included in the frame and the rear-view image displayed.

3.2. Extract photographic data.

- (a) Using the photograph, measure the apparent length, of a 50 mm delineated section of the in-photo ruler, along the ruler's edge, closest to the rear-view image and at a point near the horizontal centre of the rear-view image.
- (b) Using the photograph, measure the horizontal width of ~~the coloured band at~~ the upper portion of each of the three test objects located at positions G, H, and I in Figure B.
- (c) Define the measured horizontal widths ~~of the coloured bands~~ of the three test objects as d_G , d_H , and d_I .

3.3. Obtain scaling factor.

Using the apparent length of the 50 mm portion of the ruler as it appears in the photograph, divide this apparent length by 50 mm to obtain a scaling factor. Define this scaling factor as $scale$.

3.4. Determine viewing distance.

Determine the actual distance from the rotated eye midpoint location (M_r) to the centre of the rear-view image. Define this viewing distance as a_{eye} .

3.5. Calculate visual angle subtended by test objects.

Use the following equation to calculate the subtended visual angles:

$$\theta_i = 60 \sin^{-1} \left(\frac{d_i}{a_{eye} S_{scale}} \right)$$

where i can take on the value of either test object G, H, or I, and arcsine is calculated in units of degrees.

Figure C
Eye Midpoint location (M_f) in the mid-sagittal plane with respect to R point for forward-looking 50th percentile male driver seated with 25 degree seat back angle

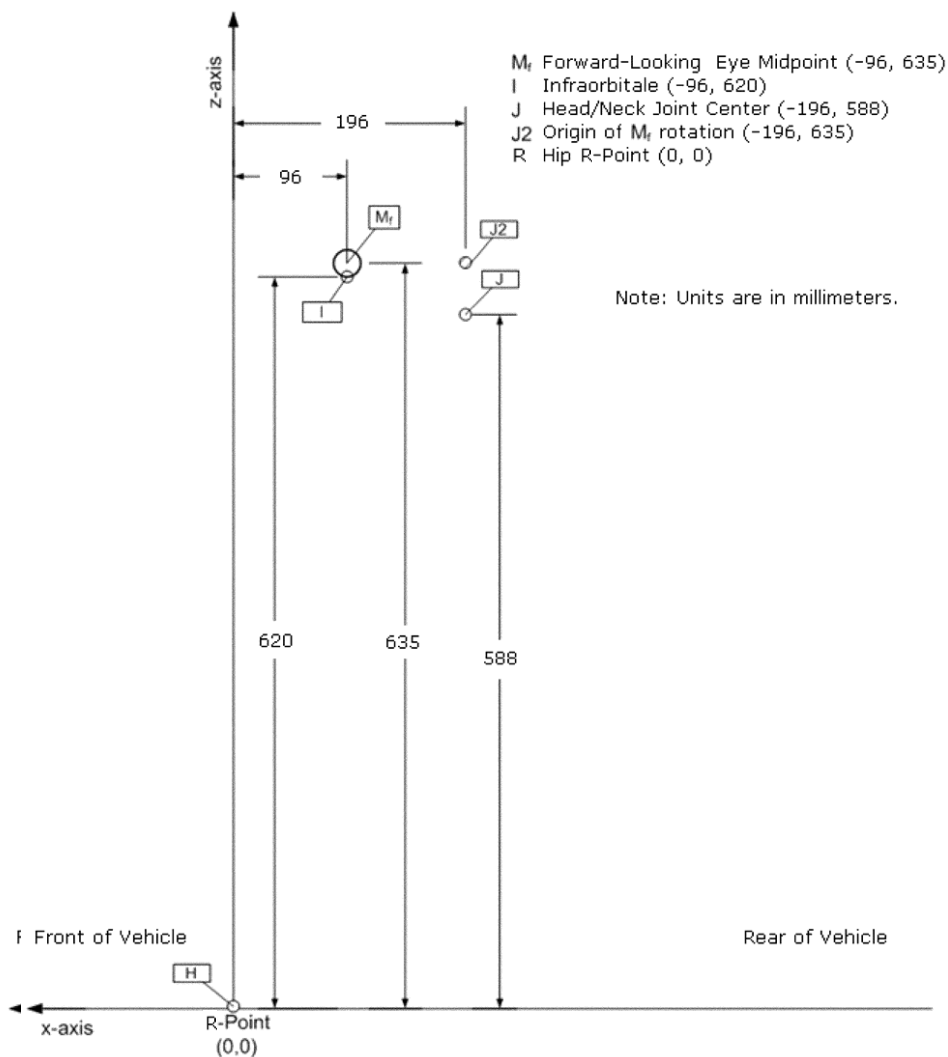

Annex 10

Test methods for detection systems

1. Rear horizontal area detection

~~Audible warning~~ **Detection** systems shall fulfil the test as specified in paragraph 1.3.1. in this Annex. However, if ~~Audible warning~~ **detection** systems fulfil the test as specified in paragraph 1.4. in this Annex, the test as specified in paragraph 1.3.1. in this Annex shall be considered to be satisfied.

1.1. Test conditions

The test object shall be as per paragraph 7.1. of ISO 17386:2010. During testing, the wind speed shall not exceed 1 m/s. The temperature shall be $20 \pm 5^\circ\text{C}$ and the humidity shall be 60 ± 25 percent. There shall be no rain or snow. The test shall be performed on a flat, dry asphalt or concrete surface. The test shall not be affected by the reflection of sound waves or electromagnetic waves from any walls, auxiliary testing equipment or any other objects in the environment.

1.2. Test preparation

One test object shall be used. The distance from the rear edge to the test object and the position of the test object are selected by the manufacturer to ensure the detection of the test object. The test object shall be located in the detectable grids within the rear horizontal area in 1.3.1. of this annex. The test vehicle in the initial state shall be with the detection system in the activated state, which is declared [by the manufacturer OR in the owner's manual] and shall be in the parking condition. Here, the parking condition means that the P (park) position is selected in the case of vehicles equipped with automatic transmissions, whereas it means the neutral gear being selected and the parking brake being engaged in the case of vehicles equipped with manual transmissions.

1.3. Test method

1.3.1. Field of detection

The maximum detection distance in paragraphs 5.4.2. and 5.4.3. of ISO 17386:2010 shall be 1.0 m (Class R2). The width of the rectangle, w_r , is equal to the vehicle width, measured along the rear axle. The dimensions shall be rounded up to the nearest 0,1 m. The figure below gives examples of different w_r . (Figure 1 and 2).

Figure 1

In the case of odd-numbered poles in the vehicle lateral direction (e.g. $w_r=1.67\text{m}$)

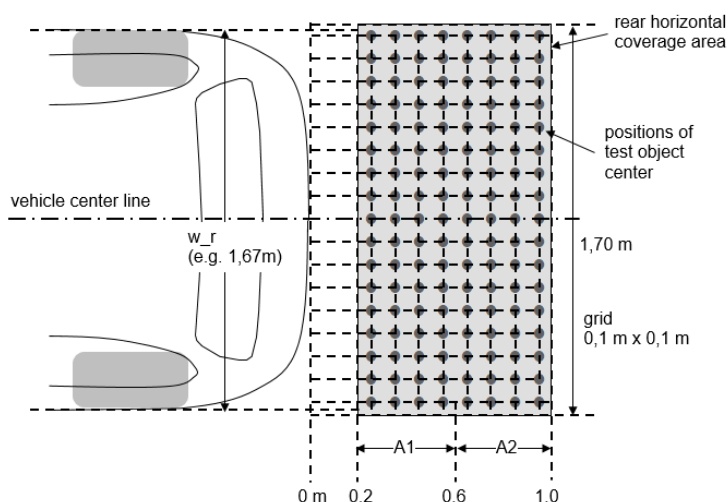
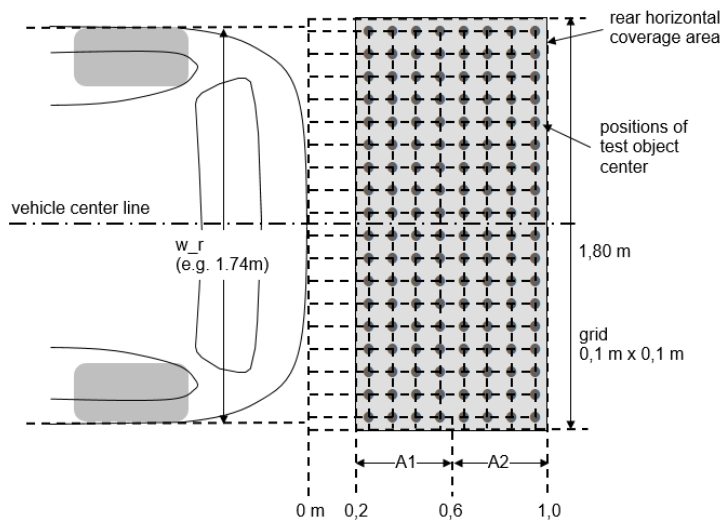

Figure 2
In the case of even-numbered poles in the vehicle lateral direction (e.g. $w_r=1,74\text{m}$)



1.3.2. Minimum detection rate

The minimum detection rate required for the rear horizontal area shall be as follows:

- (a) 90 percent for A1 as defined in paragraph 5.4.3. of ISO 17386:2010;
- (b) 87 percent for the rear-2 range in A2 as defined in paragraph 5.4.3. of ISO 17386:2010.

There shall be no undetected hole larger than a square consisting of two-by-two grids.

Here, the rear horizontal area test procedures shall be as per paragraph 7.3. of ISO 17386:2010.

When the warning is provided for more than 5 seconds continuously, it is judged that the test object is detected. The detection test shall be performed 1 time for each test object. However, if necessary, according to the agreement of the Technical Service and manufacturer, it can be judged that the test object is detected in case warnings are provided in 4 out of 5 tests.

1.4 Alternative (simplified) test method

1.4.1. Field of detection

The monitoring areas are the ten points shown in Figure 3 below within the monitoring area of paragraph 1.3.1.

Figure 3

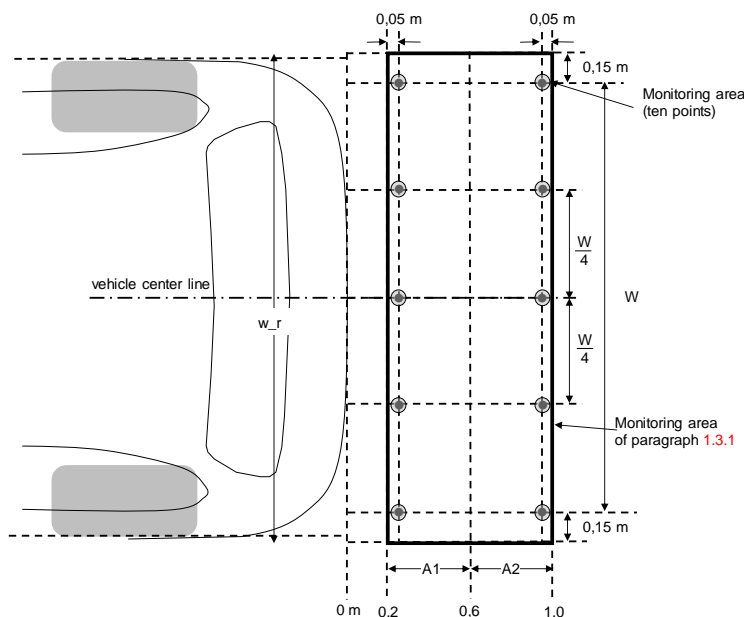

1.4.2. Minimum detection rate

The minimum detection rate required for the area of ten points shall be 100%.

When the warning is provided for more than five seconds continuously, it is judged that the test object is detected. The detection test shall be performed one time for each test object. However, if necessary, according to the agreement of the Technical Service and manufacturer, it can be judged that the test object is detected in case warnings are provided in four out of five tests.

1.4.3. Self-test capabilities and failure indication

As per paragraph 5.5. of ISO 17386:2010, the system shall provide self-test functions. It shall provide system failure information which complies with paragraph 17.2.5. of this Regulation, whenever a fault condition is detected.

2. Response time

2.1. Test conditions

- (a) The vehicle shall be left in a parked parking status until it is ensured that all electronic systems are de-activated; or for a minimum of 30 minutes.
- (b) It is permissible for the test person or equipment to be already situated within the vehicle.
- (c) Ensure the vehicle gear selector is in neutral or forward gear.
- (d) The test may start with opening the driver door. Once the door is opened, it shall be closed again.

2.2. Test procedure

- (a) Place a test object in the required field of detection
- (b) Put the vehicle into the active vehicle mode. This action shall initiate/start the first timer.
- (c) Wait for a minimum of 6 sec
- (d) Start the backing event by selecting the reverse mode. If it is not possible to put the vehicle into reversing mode 6 sec after being put into active vehicle mode, the backing event shall be started as soon as technically possible. Initiate/start the second timer, in accordance with the manufacturer's specification and no later than when the reverse

mode or gear is engaged.

- (e) Record the response time on second timer until information signal is available."
