

# IWG Safer Transport of Children in Buses and Coaches

Fifth meeting

28/01/2021

OICA



# CRS installation in buses & coaches

- Influence on interior arrangements of buses & coaches:
  - 1) Seat dimensions and spacing
  - 2) Access to the vehicle seats
  - 3) Relevant vehicle classes
  - 4) 2-pts belt / 3-pts belt restraint availability
  - 5) In-vehicle child seats (eg: Sit Safe)
  - 6) Support leg assessment volume
  
- France, Germany, Spain and UK accident data



# Influence on interior arrangements of buses

## 1) Seat dimensions and spacing

**Using UN R 129-CRS would lead to larger seat spacing and a significant loss of seats in the vehicles**

Seat spacing  
UN-R107 Annex 3 §7.7.8.4

	H
Classes I, A and B	650 mm
Classes II and III	680 mm

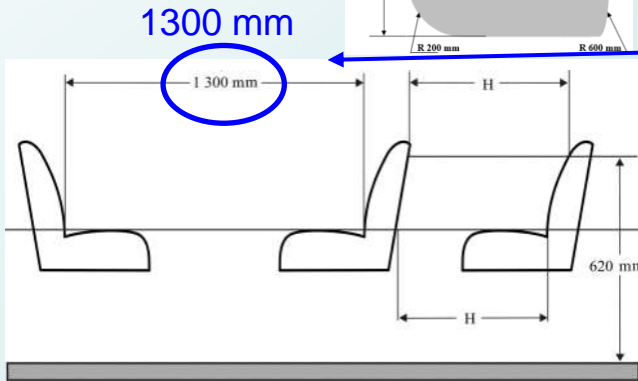
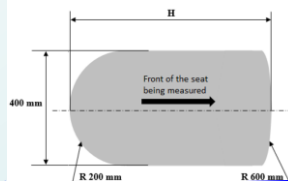

Front-facing ISO/F3 CLASS A

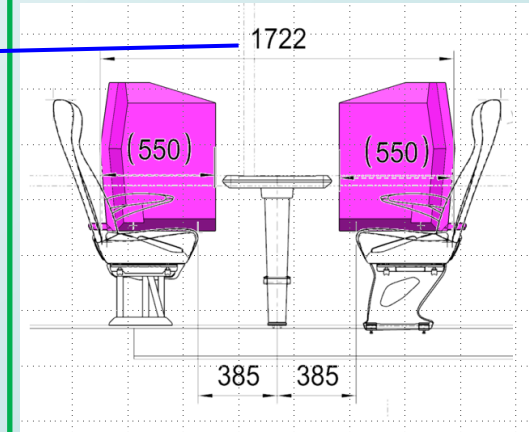
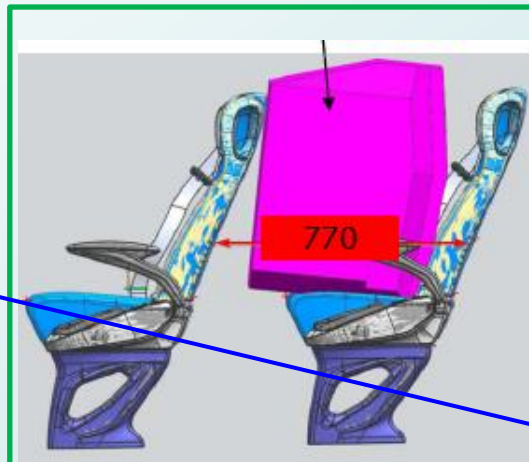

Rear-facing ISO/R2 CLASS D

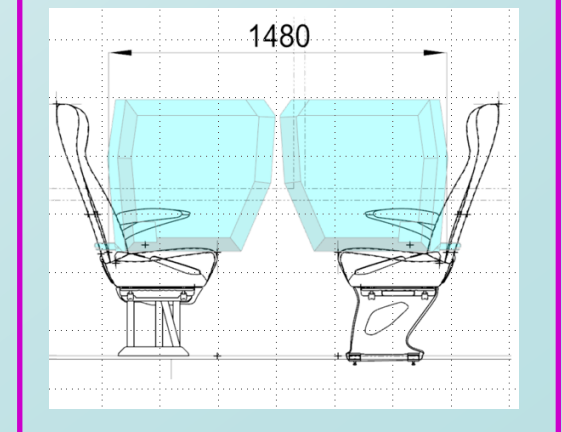
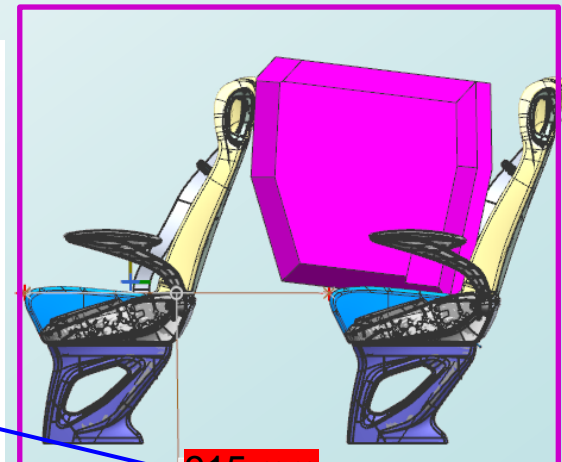



# Influence on interior arrangements of buses

## 1) Seat dimensions and spacing

### Permitted intrusions acc. to UN R 107 are in conflict with the dimensions of UN R 129-CRS!

Permitted intrusion above a seating position  
UN-R107 Annex 3 §7.7.8.6.3.2

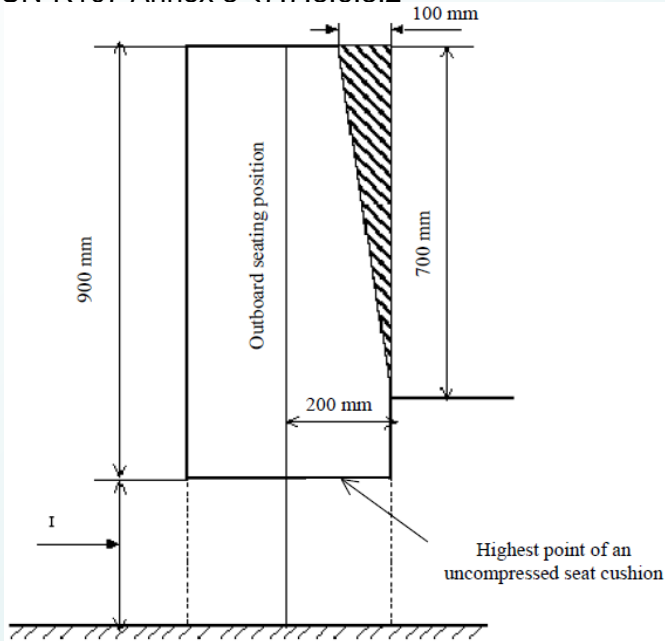

I (mm)

400 to 500  
(for Classes A, B, I and II min 350 mm at wheel arches and engine compartment(s))

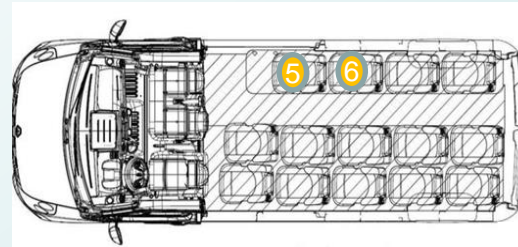

Cantrail

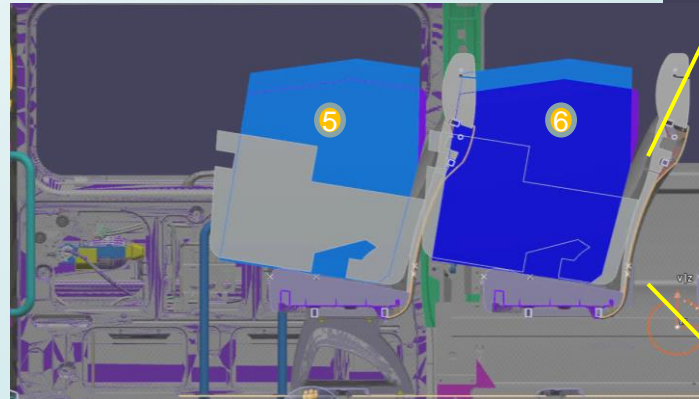

Front view

Handrail

Top view

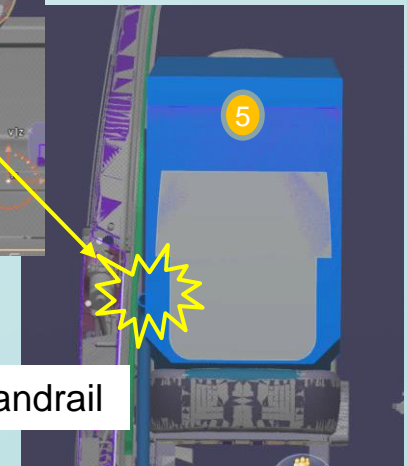
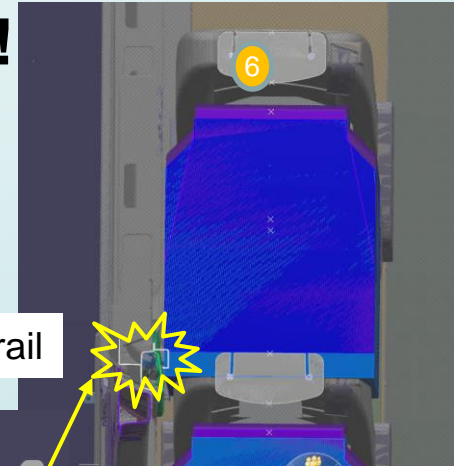



# Influence on interior arrangements of buses

## 2) Access to the vehicle seats

**UN R 107 Gangway dimensions do not permit to move the CRS to the individual passenger seats!**

Gangway mannequin (Class B)  
UN-R107 Annex 3 §7.7.8.6.3.2

Class	B (mm)	C (mm)	D (mm)	E (mm)	F (mm)
I	550	450	500	1900	900
A and II	550	350	500	1900	900
B	450	300	300	1500	900
III	450	300	500	1900	900

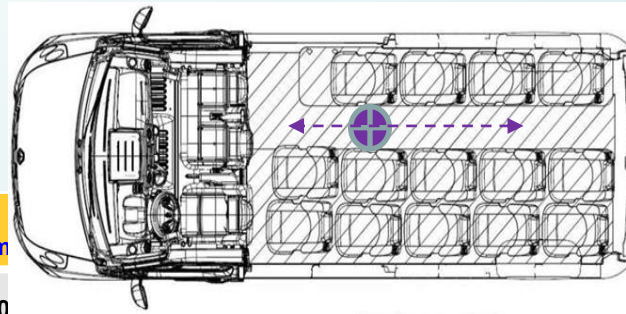

Class B mannequin

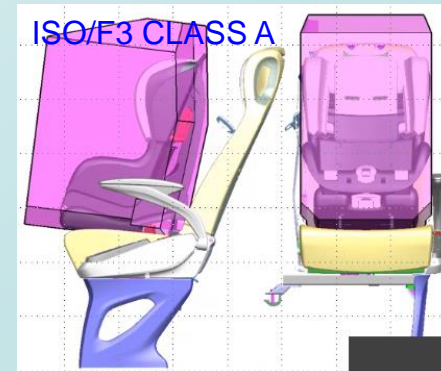
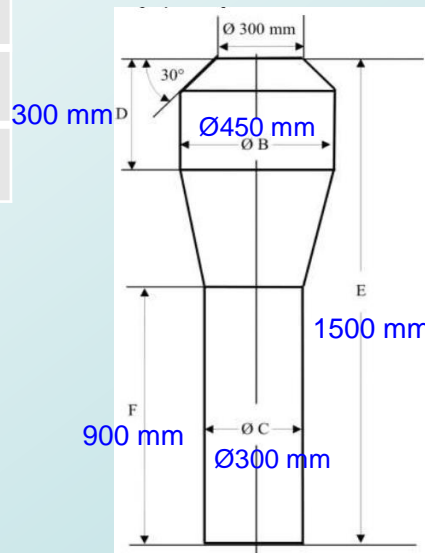



# Influence on interior arrangements of buses

## 3) Relevant vehicle classes

### Seat belt fitting in Class II – vehicles follows national regulations of CPs – harmonisation needed?

			UN-R16 Minimum requirements for safety belts		
Number of passengers	Accommodation of passengers	Class	GVM ≤ 5t (M2)		GVM > 5t (M3)
			GVM ≤ 3.5t	GVM > 3.5t	
9 - 22	Standing +seated	A	No *	No *	No *
	All seated	B	3-pt belt **	2-pt belt **	2-pt belt **
> 22	Standing & seated (urban)	I	No *	No *	No *
	Mostly seated (interurban)	II	No ***	No ***	No ***
	All seated (coach)	III	3-pt belt	2-pt belt **	2-pt belt **

\* When fitted, safety-belts must be in compliance with this regulation

\*\* 8.1.7 – 3-pt belt must be installed unless:

- 1) Reference zone empty or
- 2) UN-R80 seat or
- 3) Parts fulfilling UN-R80 energy absorption test.

\*\*\* Contracting Parties applying this Regulation may demand the installation of safety belts on M2 and M3 vehicles belonging to Class II.



# Influence on interior arrangements of buses

## 4) 2-pts belt / 3-pts belt availability

**Most vehicles on the market are fitted with 2P-belts with energy absorbing zones!**

			UN-R16 Minimum requirements for safety belts		
Number of passengers	Accommodation of passengers	Class	GVM ≤ 5t (M2)		GVM > 5t (M3)
			GVM ≤ 3.5t	GVM > 3.5t	
9 - 22	Standing +seated	A	No *	No *	No *
	All seated	B	3-pt belt **	2-pt belt **	2-pt belt **
> 22	Standing & seated (urban)	I	No *	No *	No *
	Mostly seated (interurban)	II	No ***	No ***	No ***
	All seated (coach)	III	3-pt belt	2-pt belt **	2-pt belt **

\* When fitted, safety-belts must be in compliance with this regulation

\*\* 8.1.7 – 3-pt belt must be installed unless:

- 1) Reference zone empty or
- 2) UN-R80 seat or
- 3) Parts fulfilling UN-R80 energy absorption test.

\*\*\* Contracting Parties applying this Regulation may demand the installation of safety belts on M2 and M3 vehicles belonging to Class II.



# Influence on interior arrangements of buses

## 5) In-vehicle child seats

**CRS-bus approval shall follow prescriptions on UN R 80 – basis, shall be technology neutral and not focused on existing R 129-CRS**

Eg: SiTSafe as a solution for option in Nordic bus procurement requirements

« At least 2 child seats for 3 years of age (UN-R44) »







# Influence on interior arrangements of buses

## 6) Support leg volume assessment

**Support leg might lead to further increase of seat spacing and further loss of seats in the vehicle!**

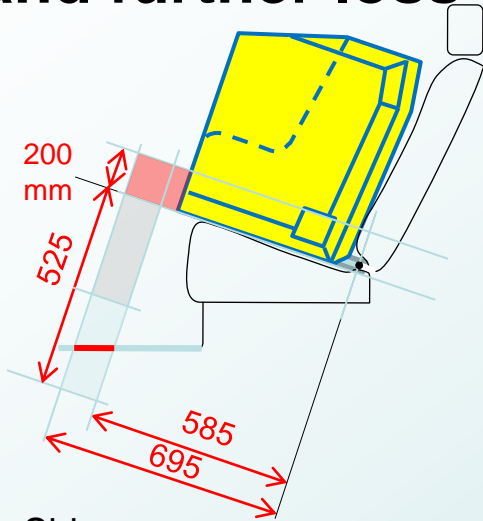

Side view

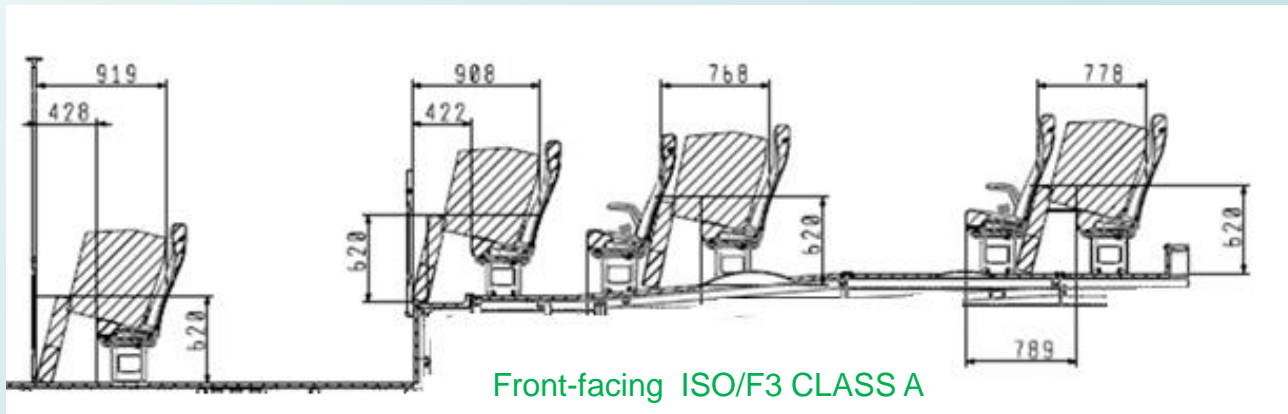
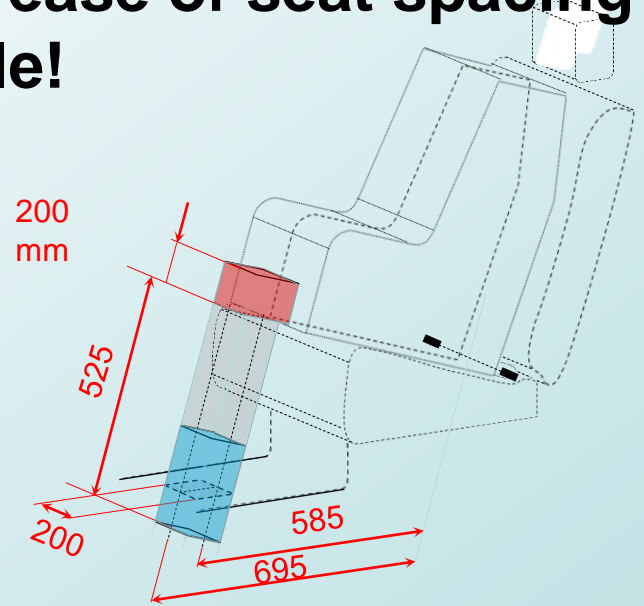

Front-facing ISO/F3 CLASS A



# France, Germany, Spain and UK accident data

In-depth data: CEESAR in-depth accident investigations

Age distribution of injured child victims (N=325 occupants, n=12 unknown):

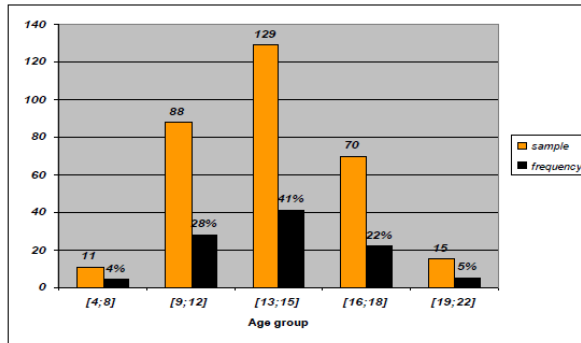

The 13-15 year-old age group shows the highest number of victims.

- Most of injured children are above 9 years old
- Most of them were not restrained.

In-depth data: GIDAS – German in depth accident study

GIDAS: Injury overview of child bus occupants



SEATED



NOT SEATED

	Head	Neck	Thorax	Arms	Abdom	Pelvis	Legs
AIS 1	13	0	2	1	2	1	4
AIS 2			1		1		
AIS 1	13	2	4	6	0	0	4
AIS 2	1						

- Majority of injuries were minor head injuries, mostly contusions or cuts to the face which were caused by contact with the front seat (by braking manoeuvres) or with grab poles inside the bus
- Not seated: High incidence of injuries to the arms from falling over (contusions, abrasion wounds)



# SUMMARY

- We identified some issues with significant influence on vehicle and its interior and seating layout :
  - ✓ CRS according to UN-R129 seem not to be compatible with Bus interior arrangements according to UN-R 107
  
- France, Germany, Spain and UK accident data :
  - ✓ Main victim population: 9 years and older
  - ✓ Cause: unrestrained
  
- We propose to seek guidance from GRSG
  - ✓ How to deal with vehicle requirements (UN-R107)
  - ✓ Number of designated CRS places in the vehicle needed?
  - ✓ ToR of the IWG to be amended accordingly