



Economic and Social Council

Distr.: General
9 April 2021

Original: English

Economic Commission for Europe

Inland Transport Committee

World Forum for Harmonization of Vehicle Regulations

184th session

Geneva, 22-24 June 2021

Item 4.9.1 of the provisional agenda

1958 Agreement:

Consideration of draft amendments to existing

UN Regulations submitted by GRBP

Proposal for Supplement 24 to the 02 series of amendments to UN Regulation No. 30 (Tyres for passenger cars and their trailers)

Submitted by the Working Party on Noise and Tyres*

The text reproduced below was adopted by the Working Party on Noise and Tyres (GRBP) at its seventy-second session (ECE/TRANS/WP.29/GRBP/71, para. 10). It is based on ECE/TRANS/WP.29/GRBP/2021/4. It is submitted to the World Forum for Harmonization of Vehicle Regulations (WP.29) and to the Administrative Committee (AC.1) for consideration at their June 2021 sessions.

* In accordance with the programme of work of the Inland Transport Committee for 2021 as outlined in proposed programme budget for 2021 (A/75/6 (Sect.20), para 20.51), the World Forum will develop, harmonize and update UN Regulations in order to enhance the performance of vehicles. The present document is submitted in conformity with that mandate.



Paragraph 3.1.14., symbol, replace to read:

"

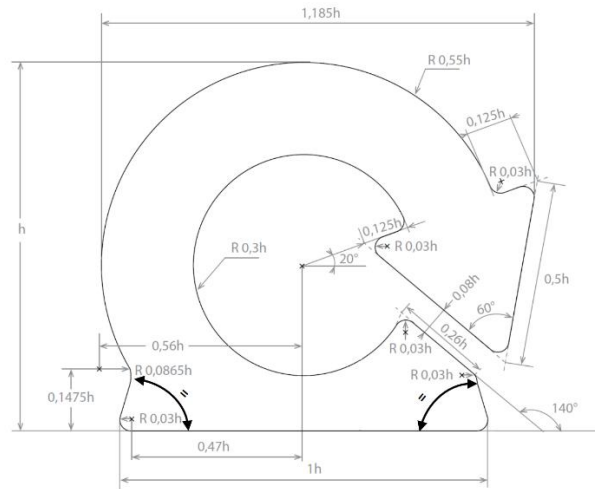

"

Annex 7

Paragraph 3.2., amend to read:

"3.2. Inflate the tyre to an inflation pressure of 2.5 bar and condition the tyre-and-wheel assembly at a test room temperature of $38\text{ }^\circ\text{C} \pm 3\text{ }^\circ\text{C}$ for not less than three hours."

Paragraph 3.7., amend to read:

"3.7. During the test the temperature of the test room must be maintained at $38\text{ }^\circ\text{C} \pm 3\text{ }^\circ\text{C}$.

The temperature sensor shall be at a distance not less than 0.15 m and not more than 1.00 m from the tyre sidewall."

Paragraph 4.2., amend to read:

"4.2. Inflate it to an inflation pressure of 2.5 bar and condition the tyre-and-wheel assembly at a test room temperature of $25\text{ }^\circ\text{C} \pm 3\text{ }^\circ\text{C}$ for not less than three hours."

Paragraph 4.7., amend to read:

"4.7. During the test the temperature of the test room must be maintained at $25\text{ }^\circ\text{C} \pm 3\text{ }^\circ\text{C}$.

The temperature sensor shall be at a distance not less than 0.15 m and not more than 1.00 m from the tyre sidewall."