



# Economic and Social Council

Distr.: General  
2 March 2021

Original: English

---

## Economic Commission for Europe

### Inland Transport Committee

### World Forum for Harmonization of Vehicle Regulations

#### Working Party on Passive Safety

#### Sixty-ninth session

Geneva, 17-21 May 2021

Item 12 of the provisional agenda

**UN Regulation No. 129 (Enhanced Child Restraint Systems)**

## **Proposal for draft Supplement 7 to the 02 series of amendments to Regulation No. 129 (Enhanced Child Restraint Systems)**

### **Submitted by the expert from Spain\***

The text reproduced below was prepared by the expert from Spain on behalf of the Technical Services Group (TSG) on UN Regulation No. 129. The modifications to the current text of the UN Regulation are marked in bold for new or strikethrough for deleted characters.

---

\* In accordance with the programme of work of the Inland Transport Committee for 2021 as outlined in proposed programme budget for 2021 (A/75/6 (Sect.20), para 20.51), the World Forum will develop, harmonize and update UN Regulations in order to enhance the performance of vehicles. The present document is submitted in conformity with that mandate.



## I. Proposal

Paragraph 7.1.3., amend to read:

"7.1.3. Dynamic Testing for Frontal, Rear and Lateral Impact:

- (a) Frontal impact test shall be performed on ~~i-Size (Integral Universal ISOFIX Enhanced Child Restraint Systems), Specific vehicle ISOFIX Enhanced Child Restraint Systems and to non-integral Enhanced Child Restraint Systems i-Size booster seats and specific vehicle booster seats; all Enhanced Child Restraint Systems within the scope of this Regulation.~~

- (b) ~~Rear impact test shall be performed on i-Size and Specific Vehicle ISOFIX Rearward and Lateral facing Enhanced Child Restraint Systems;~~

**Lateral impact tests shall be performed on all Enhanced Child Restraint Systems within the scope of this Regulation, except for built in enhanced child restraint systems.**

- (c) ~~Lateral impact test are performed only on the test bench for i-Size Integral Universal ISOFIX Enhanced Child Restraint Systems, Specific vehicle ISOFIX and for non-integral Enhanced Child Restraint Systems i-Size booster seats and specific vehicle booster seats;~~

**Rear impact tests shall be performed on all rearward and lateral facing Enhanced Child Restraint Systems within the scope of this Regulation.**

- (d) ~~The ECRS shall be tested in its most upright used position. If this upright position falls outside the Seat Fixture, this position shall still to be chosen. However with width positions outside the Seat Fixture, for the lateral test the width position of lateral shock absorbers that still fit in the Vehicle Seat Fixture shall be chosen;~~

**The frontal and rear impacts shall be performed on the test bench (trolley plus standard seat) or in the vehicle bodyshell, according to paragraph 6.6.4.1. table 4, or in a complete vehicle according to paragraph 7.1.3.3. The lateral impact tests shall be performed on the test bench only, according to paragraph 6.6.4.1. table 4.**

- (e) ~~The lateral dynamic test(s) will be performed in this(ese) configuration(s);~~

**For lateral impacts tests the Enhanced Child Restraint Systems shall be tested in its most upright used position. If this upright position falls outside the Vehicle Seat Fixture, this position shall still be chosen.**

**For Enhanced Child Restraint Systems that fit into any of the vehicle seat fixtures where the lateral shock absorbers can be adjusted outside the Vehicle Seat Fixture, the width position of the lateral shock absorbers that still fit in the Vehicle Seat Fixture shall be chosen;**

**For Enhanced Child Restraint Systems that do not fit into any of the vehicle seat fixtures, a lateral test shall be performed for each listed vehicle.**

**For each test, the initial position of the side impact door panel relative to the bench shall be adjusted according to the minimum distance between the vehicle's door panel and the centre of the seating position as shown in figure 3.**

Figure 3  
Minimum distance for lateral impact

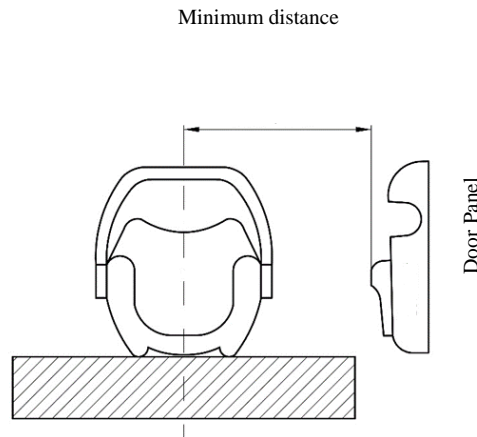

- (f) For frontal and rear impacts, the tests shall be performed with the ~~ECRS~~ **Enhanced Child Restraint System** adjusted to the size of the dummy (ies) selected to cover the entire size range, in the child seating position representing ~~the worst case for this dummy and impact orientation; the most upright position and the most reclined position for each dummy and impact orientation.~~

**If not yet covered by the previous configurations, the Technical Service may test the Enhanced Child Restraint Systems in a position defined by the Technical Service that it fits in the Vehicle Seat Fixture.**

- (g) **For frontal, rear and lateral tests** ~~An~~ **an** anti rebound device acting on the vehicle seatback shall stay inside the seat fixture in one position, but may protrude beyond the ~~seat fixture~~ **Vehicle Seat Fixture** in its adjusted position according to the user manual."

*Paragraph 7.2.8., amend to read:*

- 27.2.8. The complete seat, or the component fitted with ISOFIX attachments (e.g. ISOFIX base) if it has a release button, is attached rigidly to a test rig in such a way that ISOFIX connectors are vertically aligned as shown in Figure 3 ~~4~~. A 6 mm diameter bar, 350 mm long, shall be attached to the ISOFIX connectors. A mass of 5 kg shall be attached to the extremities of the bar."

*Paragraph 7.2.8.5., Figure 3 (former), renumber as Figure 4.*

## II. Justification

Paragraph 7.1.3. covers the test configurations that shall be used during the type approval process. This proposal clarifies the application of the dynamic test procedures for Enhanced Child Restraint Systems. It specifies the installation configurations to be tested and aims to clarify the tests conducted in a consistent way by Technical Services.