

**Economic and Social Council**Distr.: General
10 February 2021

Original: English

Economic Commission for Europe**Inland Transport Committee****World Forum for Harmonization of Vehicle Regulations****Working Party on Lighting and Light-Signalling****Eighty-third session**

Geneva, 26-30 April 2021

Item 5 of the provisional agenda

UN Regulations Nos. 37 (Filament lamps), 99 (Gas discharge light sources), 128 (Light emitting diodes light sources) and the Consolidated Resolution on the common specification of light source categories**Proposal for amendment to the Consolidated Resolution on the common specification of light source categories (R.E.5)****Submitted by the Task Force on Substitutes and Retrofits***

The text reproduced below was prepared by the Task Force on Substitutes and Retrofits (TF SR), with the aim to introduce a new light emitting diode (LED) replacement light source category H11. This proposal supersedes ECE/TRANS/WP.29/GRE/2020/16 and is based on informal document GRE-83-13, presented at the eighty-third session of the Working Party on Lighting and Light-Signalling (GRE). The technical provisions are based on the equivalence criteria (informal document GRE-83-15). The modifications to the existing text of the Resolution are marked in bold for new or strikethrough for deleted characters.

* In accordance with the programme of work of the Inland Transport Committee for 2021 as outlined in proposed programme budget for 2021 (A/75/6 (Sect.20), para 20.51), the World Forum will develop, harmonize and update UN Regulations in order to enhance the performance of vehicles. The present document is submitted in conformity with that mandate.

I. Proposal

The Status table, insert a new row at the bottom to read:

“

Amendment [x] to the Original Version	[xx.xx.2021]	[...]	[ECE/TRANS/WP.29/2021/xx]	Introduction of a new LED replacement light source category H11 as a package with Supplement [x] to UN Regulation No. 37
---------------------------------------	--------------	-------	---------------------------	--

”

Insert a new subparagraph 2.1.1.3.2., to read:

“2.1.1.3.2. “LED replacement light source” means a LED light source designed to replace in a device a counterpart light source with the same category designation, producing light by another light generating technology.”

Renumber paragraph 2.1.4. into paragraph 2.1.5.

Insert a new paragraph 2.1.4., to read:

“2.1.4. “AE device” means an additional electronics device not integrated with, but designed to connect to, a high-efficiency LED replacement light source with the purpose to augment the electrical current without changing the other characteristics of this light source.”

Paragraph 3.1., the title, amend to read:

“3.1. Filament light sources (incandescent technology)”

Paragraph 3.3., insert a new Group 5, to read:

Group 5	
<i>LED replacement light source categories^{3,4} only for use in lamps approved with filament light source(s) with the same category designation</i>	
Category	Sheet number(s)
H11	H11_LED/1 to 7

³ not for use in type approval of lamps

⁴ not for use in conformity of production control of lamps”

Annex 1, the title, amend to read:

“Annex 1 Sheets for filament light sources (incandescent technology)”

Annex 3, insert new sheet numbers, to read:

“List of sheets for LED light sources and their sequence in this annex:

<i>Sheet number(s)</i>
C5W/LED/1 to 4
H11/LED/1 to 7
H11_LED/1 to 7
L1/1 to 5
LR1/1 to 5
LW2/1 to 5
L3/1 to 6
LR4/1 to 5
L5/1 to 6

Sheet number(s)

PY21W/LED/1 to 4

R5W/LED/1 to 4

W5W/LED/1 to 4

”

*After sheet H11/LED/7, insert new sheets H11_LED/1 to 7, to read:
(see the following pages; one page per sheet)*

The drawings are intended only to illustrate the essential dimensions (in mm) of the LED light source.

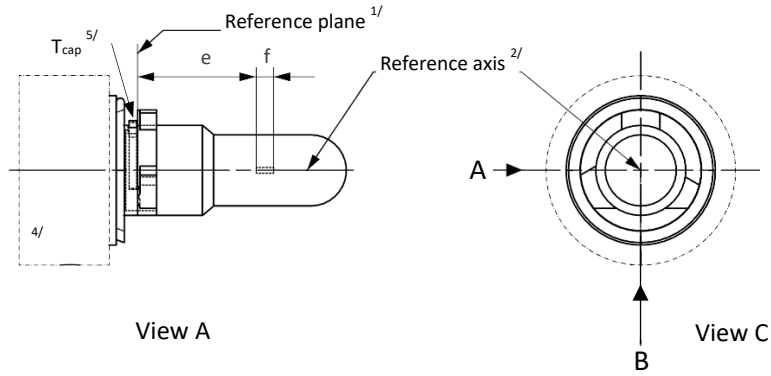

Figure 1: Main drawings

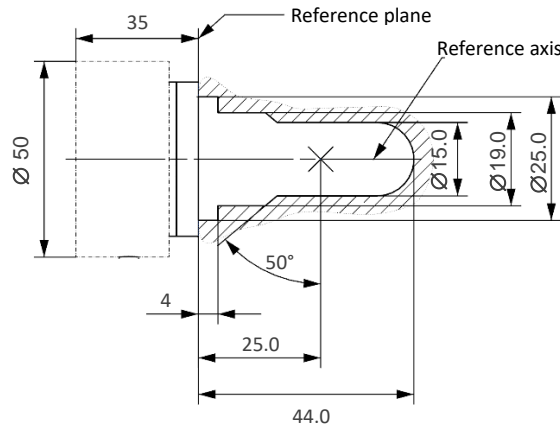

Figure 2: Maximum LED light source outline ^{3/}

- ^{1/} The reference plane is the plane formed by the underside of the bevelled lead-in flange of the cap.
- ^{2/} The reference axis is perpendicular to the reference plane and passing through the centre of the 19 mm cap diameter.
- ^{3/} The LED light source shall not exceed the envelope as indicated in Figure 2.
- ^{4/} The light source shall function in either voltage polarity.
- ^{5/} Measurement point for cap temperature T_{cap}

Category H11

Sheet H11_LED/2

Table 1
Essential electrical and photometrical characteristics of the LED light source

Dimensions in mm		LED light sources of normal production		
e ^{2/}		25.0 nom.		
f ^{2/}		4.5 nom.		
Contrast ^{6/}		100 min.		
Elevated ambient air temperature ^{3/}		60°C		
Cap H11 PGJ19-2 ^{9/}		in accordance with IEC Publication 60061 (sheet 7004-110-3)		
Electrical and photometric characteristics		^{4/}	^{5/}	
Rated values	Volts	12	24	
	Watts	27 ^{11/}	27 ^{11/}	
Test voltage (DC)	Volts (DC)	13.2	28.0	
Objective values	Power ^{8/}	Watts	27 min. ^{10/} 62 max. ^{11/}	27 min. ^{10/} 62 max. ^{11/}
	Cap temperature T _{cap}	°C	120 max. ^{10/}	120 max. ^{10/}
	Electrical current ^{8/}	mA	2000 min. ^{10/} (at 12-14 V DC)	1000 min. ^{10/} (at 24-28 V DC)
	Luminous flux ^{1/} ^{3/}	lm	1,350 ± 10%	
	Luminous flux deviation ^{7/} (voltage range limits)	lm	±10% (at 12V) ±10% (at 14V)	±10% (at 24V) ±10% (at 28V)

^{1/} The light emitted shall be white without a correlated colour temperature restriction.

^{2/} To be checked by means of a "box system", sheet H11 LED/3

^{3/} The luminous flux measured at the elevated ambient air temperature shall be at least 75% of the objective luminous flux (both measured at test voltage)

^{4/} In case of a failure of any of the light emitting elements (open circuit failure), the LED light source shall either still comply to the requirements concerning luminous flux and luminous intensity distribution or stop emitting light whereby, in the latter case, the electrical current draw, when operated between 12 V and 14 V, shall be less than 100 mA

^{5/} In case of a failure of any of the light emitting elements (open circuit failure), the LED light source shall either still comply to the requirements concerning luminous flux and luminous intensity distribution or stop emitting light whereby, in the latter case, the electrical current draw, when operated between 24 V and 28 V, shall be less than 50 mA

^{6/} The contrast is the proportion of luminous flux originating from two different areas, see details in sheet H11 LED/3

^{7/} The maximum luminous flux deviation at the tolerance limits is calculated by using the measured flux at test voltage as reference. The luminous flux behaviour shall be substantially uniform within the specified voltage range.

^{8/} Including AE device, if any

^{9/} The maximum specifications of parameters G and K are excluded, but the maximum outline dimensions in Figure 2 apply

^{10/} Not applicable for high-efficiency type (if no AE device is specified)

^{11/} For high-efficiency type 18W rated value and 21W max. objective value applies

Screen projection requirements

The following test is intended to define the requirements for the apparent light emitting area of the LED light source and to determine whether the light emitting area is correctly positioned relative to the reference axis and reference plane in order to check compliance with the requirements.

The position of the light emitting area is checked by a box system defined in Figure 4 when operated at test voltage, which shows the projections when viewing from B (see sheet H11 LEDr/1, Figure 1) and from A and -A (see sheet H11 LEDr/1, Figure 1), i.e. along the C-planes C₀, C₉₀ and C₂₇₀ (as defined in Figure 6).

The proportion of the total luminous flux emitted into these viewing directions from the area(s) as defined in Figure 4:

- Total box area: $(A+B+C) / E$ shall be not less than 90%
- Area A: $A / (A+B+C)$ shall be not more than 10%
- Areas B₁, B₂ and B₃: B_1/B , B_2/B , B_3/B shall each be not less than 15%
- Area B: $B / (A+B+C)$ shall be not less than 72 %
- Area C: $C / (A+B+C)$ shall be not more than 22%

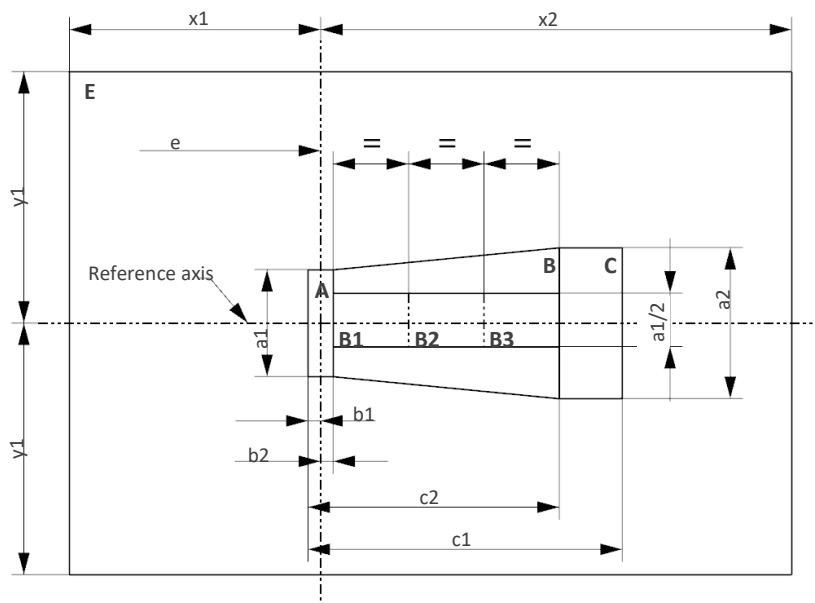

Figure 4: Box definition of the light emitting area (dimensions given in Table 2)

The contrast is checked by a box system defined in Figure 5 when operated at test voltage, which shows the projections when viewing from A and -A (see sheet H11 LEDr/1, Figure 1), i.e. along the C-planes C₉₀ and C₂₇₀ (as defined in Figure 6).

The contrast is the proportion of the total luminous flux values emitted into these viewing directions from the corresponding areas (A+B+C) and D. The value of the contrast $(A+B+C) / D$ shall be within the limits given in Table 1 (see Figure 5 for the definition of the area D).

Category H11

Sheet H11_LED/4

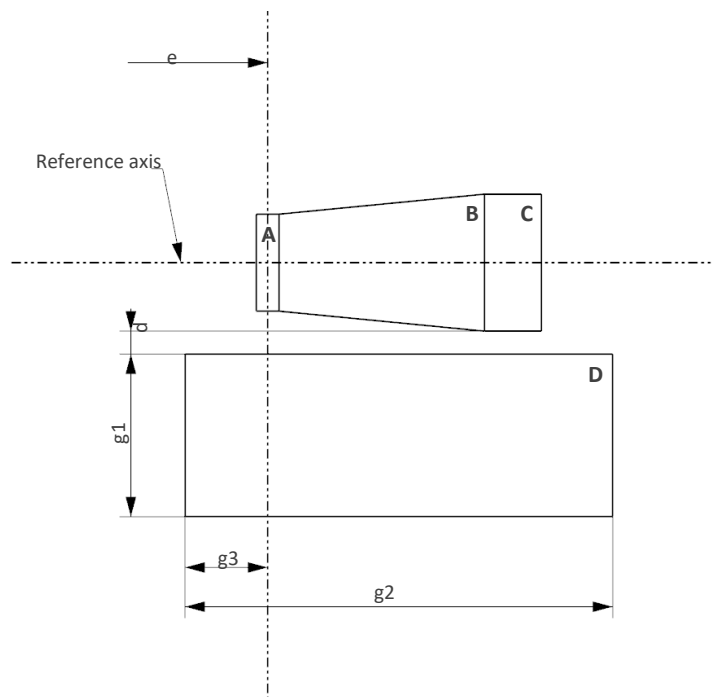

Figure 5: Box definition of the area D (dimensions given in Table 2)

Table 2

Dimensions of the box definitions in Figure 4 and Figure 5

All views (as specified above)	<i>Dimensions in mm</i>	All views (as specified above)	<i>Dimensions in mm</i>
a1	1.7	x1	25
a2	1.9	x2	19
b1	0.2	y1	12.5
b2	0.2	g1	2.85
c1	5.0	g2	7.5
c2	4.0	g3	1.45
d	0.4		

Normalized luminous intensity distribution

The following test is intended to determine the normalized luminous intensity distribution of the light source in the C-planes as described in Figure 6 when operated at test voltage. The intersection of the reference axis and the plane parallel to the reference plane at distance $e = 25.0$ mm is used as the coordinate system origin.

The light source is mounted on a flat plate with the corresponding holder features. The plate is fixed to the goniometer table by a bracket, so that the reference axis of the light source lines up with one of the rotating axis of the goniometer. The corresponding measurement set-up is described in Figure 6.

Luminous intensity data is recorded with a standard photo-goniometer. The measurement distance should be chosen appropriately in order to make sure that the detector is located in the far field of the light distribution.

The measurements shall be performed in C-planes for which the line of intersection coincides with the reference axis of the light source. The test points for each plane and polar angles γ are specified in Table 3.

The measured luminous intensity values, normalised to the measured luminous flux of the individual light source under test, shall be converted to normalised luminous intensity values of a 1000 lm light source. These data shall comply with the limits as defined in Table 3.

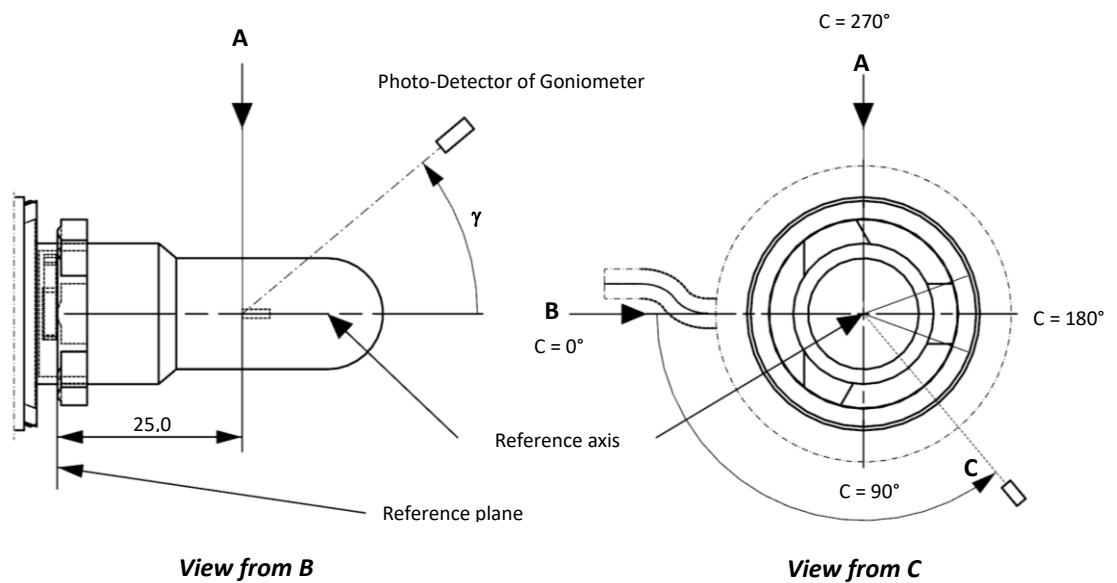

Figure 6: Setup to measure the luminous intensity distribution and the definition of C-Planes and angle γ

C-planes: see CIE publication 70-1987, "The measurement of absolute intensity distributions".

Category H11

Sheet H11_LED/6

Table 3 – Part 1

Test point values of normalized intensity (Black top area)

LED light source of normal production and standard LED light source		
	Minimum intensity (cd/klm)	Maximum intensity (cd/klm)
γ	$C_0, C_{90}, C_{180}, C_{270}$	$C_0, C_{90}, C_{180}, C_{270}$
0°	n/a	10
10°	n/a	10
20°	n/a	10
30°	n/a	10

The light pattern as described in Table 3 – part 1 shall be substantially uniform, i.e. in between two adjacent grid points the relative luminous intensity requirement is calculated by linear interpolation using the two adjacent grid points. In case of doubt this may be checked in addition to verification of the grid points given in Table 3 – part 1.

Note: The angular range in Table 3 – Part 1 is equivalent to the black top of its counterpart H11 filament light source specified by γ_3 in sheet H11/3.

Table 3 – Part 2

Test point values of normalized intensity (Distortion free area)

LED light source of normal production and standard LED light source		
	Minimum intensity (cd/klm)	Maximum intensity (cd/klm)
γ	C_0, C_{90}, C_{270}	C_0, C_{90}, C_{270}
50°	80	130
60°	80	130
70°	80	130
80°	80	130
90°	80	130
100°	80	130
110°	80	130
120°	80	130
130°	80	130
140°	80	130

The light pattern as described in Table 3 – part 2 (excluding the section between C_{90} and C_{270}) shall be substantially uniform, i.e. in between two adjacent grid points the relative luminous intensity requirement is calculated by linear interpolation using the two adjacent grid points. In case of doubt this may be checked in addition to verification of the grid points given in Table 3 – part 2.

Note: The angular range in Table 3 – Part 2 is equivalent to the distortion free area of its counterpart H11 filament light source specified by γ_2 and γ_1 in sheet H11/3.

Table 3 – Part 3
Test point values of normalized intensity (Shading area of the lead-in wire of the counterpart filament light source)

γ	LED light source of normal production and standard LED light source	
	Minimum intensity (cd/klm)	Maximum intensity (cd/klm)
C-plane	$\gamma = 90^\circ$	$\gamma = 90^\circ$
C ₀	80	130
C ₃₀	80	130
C ₆₀	80	130
C ₉₀	80	130
C ₁₂₀	80	130
C ₁₅₀	80	130
C ₁₈₀	n/a	n/a
C ₂₁₀	80	130
C ₂₄₀	80	130
C ₂₇₀	80	130
C ₃₃₀	80	130
C ₃₃₀	80	130
C ₃₆₀ (= C ₀)	80	130

The light pattern as described in Table 3 – part 3 (excluding the section between C₁₅₀ and C₂₁₀) shall be substantially uniform, i.e. in between two adjacent grid points the relative luminous intensity requirement is calculated by linear interpolation using the two adjacent grid points. In case of doubt this may be checked in addition to verification of the grid points given in Table 3 – part 3.

Note: Due to the shading area created by the lead-in wire of its counterpart H11 filament light source (opposite to the metal-free zone; see Figure 4 on sheet H11/2) there is no requirement in the C₁₈₀-plane.

II. Justification

1. This proposal specifies:
 - (a) A definition of LED replacement light source;
 - (b) A definition of AE device;
 - (c) A new group 5 for LED replacement light sources;
 - (d) A new category of LED replacement light source (LEDr) category H11.
 2. It is part of a package together with other proposals which aim to:
 - Include the possibility of approval of LED replacement light sources according to UN Regulation No. 37;
 - Exclude the possibility of approval of LED replacement light sources according to UN Regulation No. 128;
 - Inform GRE on the *Equivalence Criteria, Guide for specifying LED replacement light source categories as equivalents for corresponding filament light source categories*, intended for publication on the GRE website under the section “Documents for reference only”.
 3. This category was developed taking into account the photometric equivalence criteria including those that are specific to road illumination applications: dedicated near-field photometry including homogeneity and contrast, dedicated far-field photometry including distortion free zones and block-top region.
 4. Based on the detailed discussions in the TF SR on additional electrical and thermal characteristics necessary for safe interchangeability with filament light sources, it includes specific requirements on:
 - Photometric performance at elevated ambient temperature;
 - Photometric performance in the range of input voltages from 12 V to 14 V direct current (DC);
 - Minimum power consumption of 27 W to ensure compatibility with failure-detection systems and an option for a “high efficiency” type intended for those vehicles without failure detection;
 - Maximum cap temperature specification to avoid too high temperatures at the holder.
-