



# Economic and Social Council

Distr.: General  
3 November 2020

Original: English

Informal document GRPE-82-22  
82<sup>nd</sup> GRPE, 12-15 January 2021  
Agenda item 4(a)

Updates to GRPE/2021/6 are shown in red  
text, with **bold** and ~~strikethrough~~

## Economic Commission for Europe

### Inland Transport Committee

### World Forum for Harmonization of Vehicle Regulations

#### Working Party on Pollution and Energy

#### Eighty-second session

Geneva, 12-15 January 2021

Item 4(a) of the provisional agenda

**Heavy duty vehicles: UN Regulations Nos. 49  
(Emissions of compression ignition and positive  
ignition (LPG and CNG) engines) and 132  
(Retrofit Emissions Control devices (REC))**

### **Proposal for a new series of amendments to UN Regulation No. 49 (Emissions of compression ignition and positive ignition (LPG and CNG) engines)**

#### **Submitted by the European Commission\***

The text reproduced below was prepared by the expert from the European Commission to introduce new requirements relating to Auxiliary Emission Strategies, cold engine starts and the use of Portable Emissions Measurement Systems (PEMS) to measure particle numbers. A new series of amendments is required because this proposed amendment introduces a new conformity factor for particle matter number. The modifications to the current text of the Regulation are marked in bold for new or strikethrough for deleted characters.

\* In accordance with the programme of work of the Inland Transport Committee for 2021 as outlined in proposed programme budget for 2021 (A/75/6 (Sect.20), para 20.51), the World Forum will develop, harmonize and update UN Regulations in order to enhance the performance of vehicles. The present document is submitted in conformity with that mandate.



## I. Proposal

*Amend paragraph 1.2., to read:*

"1.2. Equivalent approvals

The following do not need to be approved according to this Regulation: engines mounted in vehicles of up to 2,840 kg reference mass to which an approval to Regulation No. 83 or **Regulation No. [154]** has been granted as an extension. "

*Insert a new paragraph 2.46.1., to read:*

**"2.46.1. "Particulate Matter number" (PM number) means the total number of solid particles emitted from the exhaust quantified according to the dilution, sampling and measurement methods as specified in Annex 4."**

*Paragraph 3.1.3., amend to read:*

"3.1.3. Together with the application, the manufacturer shall provide a documentation package that fully explains any element of design which affects emissions, the emission control strategy of the engine system, the means by which the engine system controls the output variables which have a bearing upon emissions, whether that control is direct or indirect, **anti-tampering measures** and fully explains the warning and inducement system required by paragraphs 4. and 5. of Annex 11. ~~The documentation package shall consist of the following parts including the information set out in paragraph 5.1.4.:~~

- ~~(a) A formal documentation package that shall be retained by the Type Approval Authority. The formal documentation package may be made available to interested parties upon request;~~
- ~~(b) An extended documentation package that shall remain confidential. The extended documentation package may be kept by the Type Approval Authority or be retained by the manufacturer, at the discretion of the Type Approval Authority, but shall be made available for inspection by the Type Approval Authority at the time of approval or at any time during the validity of the approval. When the documentation package is retained by the manufacturer, the Type Approval Authority shall take the necessary measures to ensure that the documentation is not being altered after approval.~~

**The documentation package shall be identified and dated by the approval authority and kept by that authority for at least 10 years after the approval is granted.**

**The documentation package shall consist of the following parts:**

- (a) The information set out in paragraph 5.1.4.;**
- (b) An AES documentation package, as described in Annex 2D to this Regulation in order for the approval authorities to be able to assess the proper use of AES.**

**At the request of the manufacturer, the approval authority shall conduct a preliminary assessment of the AES for new vehicle types. In that case, the manufacturer shall provide the draft AES documentation package to the approval authority between 2 and 12 months before the start of the type-approval process.**

**The approval authority shall make a preliminary assessment on the basis of the draft AES documentation package provided by the manufacturer. The approval authority shall make the preliminary assessment in accordance with the methodology described in Appendix 2 to Annex 10. The approval authority may deviate from that methodology in exceptional and duly justified cases.**

**The preliminary assessment of the AES for new vehicle types shall remain valid for the purposes of type approval for a period of 18 months. That period may be extended by a further 12 months if the manufacturer provides the approval authority with proof that no new technologies have become available on the market that would change the preliminary assessment of the AES."**

*Paragraph 4.12.1.*, amend to read:

"4.12.1. An approval number shall be assigned to each type approved. Its first two digits ~~(at present 06, corresponding to 06 series of amendments)~~**(at present 07, corresponding to 07 series of amendments)** shall indicate the series of amendments incorporating the most recent major technical amendments made to the Regulation at the time of issue of the approval. The same Contracting Party shall not assign the same number to another engine type or vehicle type."

*Paragraph 5.1.4.1.*, amend to read:

"5.1.4.1. The documentation package required by paragraph 3. of this Regulation enabling the Type Approval Authority to evaluate the emission control strategies and the systems on-board the vehicle and engine to ensure the correct operation of NO<sub>x</sub> control measures, as well as the documentation packages required in Annex 10 (off-cycle emissions), Annexes 9A and 9B (OBD) and Annex 15 to this Regulation (dual-fuel engines), shall ~~be made available in the two following parts~~**include the following information:**

- (a) ~~The "formal documentation package" that may be made available to interested parties upon request~~**A full description of the inducement system required by Annex 11, including the associated monitoring strategies;**
- (b) ~~The "extended documentation package" that shall remain strictly confidential~~**The description of the anti-tampering measures considered in paragraph 3.1.4.(b) and in paragraph 3.2.4.(a)."**

*Paragraph 5.2.4.*, amend to read:

"5.2.4. For the dilute testing of positive ignition engines by using an exhaust dilution system, it is permitted to use analyser systems that meet the general requirements and calibration procedures of UN Regulation No. 83 **or Regulation No. [154]**. In this case, the provisions of paragraph 9. and Appendix 2 to Annex 4 to this Regulation shall not apply.

However, the test procedures in paragraph 7. of Annex 4 to this Regulation and the emission calculations provided in paragraph 8. of Annex 4 shall apply. "

*Paragraph 13.*, amend to read:

## **"13. Transitional provisions**

13.1. General provisions

~~13.1.1. As from the official date of entry into force of the 06 series of amendments, no Contracting Party applying this Regulation shall refuse to grant approval under this Regulation as amended by the 06 series of amendments.~~

~~13.1.2. As from the date of entry into force of the 06 series of amendments, Contracting Parties applying this Regulation shall grant ECE approvals only if the engine meets the requirements of this Regulation as amended by the 06 series of amendments.~~

**13.1.1. As from the official date of entry into force of the 07 series of amendments, no Contracting Party applying this Regulation shall refuse to grant approval under this Regulation as amended by the 07 series of amendments.**

- 13.2. ~~————~~ New type approvals
- 13.2.1. ~~————~~ Contracting Parties applying this Regulation shall, from the date of entry into force of the 06 series of amendments to this Regulation, grant an ECE approval to an engine system or vehicle only if it complies with:
- (a) ~~————~~ The requirements of paragraph 4.1. of this Regulation;
  - (b) ~~————~~ The performance monitoring requirements of paragraph 2.3.2.2. of Annex 9A in the case of compression ignition and dual fuel engines and vehicles;
  - (c) ~~————~~ The NO<sub>x</sub> OTL monitoring requirements as set out in the row "phase in period" of Table 1 of Annex 9A, in the case of compression ignition and dual fuel engines and vehicles;
  - (d) ~~————~~ The NO<sub>x</sub> OTL monitoring requirements as set out in the row "phase in period" of Table 2 of Annex 9A, in the case of positive ignition engines and vehicles;
  - (e) ~~————~~ The Reagent quality "phase-in" requirements as set out in paragraph 7.1.1.1. of Annex 11.
- 13.2.1.1. ~~————~~ In accordance with the requirements of paragraph 6.4.4. of Annex 9A manufacturers are exempted from providing a statement of OBD in use performance compliance.
- 13.2.2. ~~————~~ In the case of positive ignition engines and vehicles, Contracting Parties applying this Regulation shall, from 1 September 2014, grant a type approval to an engine system or vehicle only if it complies with:
- (a) ~~————~~ The requirements of paragraph 4.1. of this Regulation;
  - (b) ~~————~~ The NO<sub>x</sub> OTL monitoring requirements as set out in the row "phase in period" of Table 2 of Annex 9A;
  - (c) ~~————~~ The CO OTL monitoring requirements as set out in the row "phase in period" of Table 2 of Annex 9A;
  - (d) ~~————~~ The Reagent quality "phase in" requirements as set out in paragraph 7.1.1.1. of Annex 11.
- 13.2.2.1. ~~————~~ In accordance with the requirements of paragraph 6.4.4. of Annex 9A manufacturers are exempted from providing a statement of OBD in use performance compliance.
- 13.2.3. ~~————~~ Contracting Parties applying this Regulation shall, from 31 December 2015, grant a type approval to an engine system or vehicle only if it complies with:
- (a) ~~————~~ The requirements of paragraph 4.1. of this Regulation;
  - (b) ~~————~~ The PM Mass OTL monitoring requirements as set out in the row "general requirements" of Table 1 of Annex 9A in the case of compression ignition and dual fuel engines and vehicles;
  - (c) ~~————~~ The NO<sub>x</sub> OTL monitoring requirements as set out in the row "general requirements" of Table 2 of Annex 9A in the case of compression ignition and dual fuel engines and vehicles;
  - (d) ~~————~~ The NO<sub>x</sub> and CO OTL monitoring requirements as set out in the row "general requirements" of Table 2 of Annex 9A in the case of positive ignition engines and vehicles;
  - (e) ~~————~~ The Reagent quality "general requirements" as set out in paragraph 7.1.1.1. of Annex 11.
  - (f) ~~————~~ The requirements regarding the plan and implementation of the monitoring techniques according to paragraphs 2.3.1.2. and 2.3.1.2.1. of Annex 9A;

~~(g) The requirements of paragraph 6.4.1. of Annex 9A for providing a statement of OBD in use performance compliance.~~

~~13.2.4. Contracting Parties applying this Regulation may refuse type approval to an engine system or a vehicle if they do not comply with the requirements of this Supplement 5 to the 06 series of amendments of this Regulation with the exception of the requirements specified in paragraphs A.1.4.2.2.2., and A.1.4.3.1.2. of Appendix 1 to Annex 8.~~

~~13.2.5. Contracting Parties applying this Regulation shall, from 1 September 2018, grant an ECE type approval to an engine system or a vehicle only if they comply with the requirements of this Supplement 5 to the 06 series of amendments of this Regulation.~~

## **13.2. Type approvals**

**13.2.1. As from the official date of entry into force of the 07 series of amendments, Contracting Parties applying this Regulation shall grant an approval to new types of vehicle or engine only if they comply with the requirements of this Regulation, as amended by the 07 series of amendments.**

**13.2.2. By way of derogation from paragraph 13.2.1., new types of positive-ignition engines, type 1A dual-fuel engines and type 1B dual-fuel engines (in dual-fuel mode), and vehicles equipped with such engines, shall comply with the maximum allowed conformity factor for PM number according to paragraph 6.3. of Annex 8 with effect from 1 January 2023. However, as from the date of entry into force of this Regulation, the particle number work window conformity factor and CO<sub>2</sub> mass window conformity factor shall be stated in the PEMS demonstration test results in the type-approval communication for monitoring purposes.**

**13.2.3. As from the official date of entry into force of the 07 series of amendments Contracting Parties applying this Regulation shall not be obliged to accept a type-approval which has not been granted in accordance with the 07 series of amendments to this Regulation.**

**13.2.4. By way of derogation from paragraph 13.2.3., as from two years after the official date of entry into force of the 07 series of amendments, for new vehicles equipped with positive-ignition engines, type 1A dual-fuel engines and type 1B dual-fuel engines (in dual-fuel mode) which do not comply with the maximum allowed conformity factor for PM number according to paragraph 6.3. of Annex 8 and the requirements of this Regulation, Contracting Parties applying this Regulation shall not be obliged to accept a type-approval which has not been granted in accordance with the 07 series of amendments to this Regulation. However, as from the official date of entry into force of the 07 series of amendments, the particle number work window conformity factor and CO<sub>2</sub> mass window conformity factor shall be stated in the PEMS demonstration test results in the type-approval communication for monitoring purposes.**

**13.2.5. As from the official date of entry into force of the 07 series of amendments, Contracting Parties applying this Regulation shall not be obliged to accept a type-approval for a vehicle with a reference mass exceeding 2,380 kg but not exceeding 2,610 kg, which has not been granted in accordance with the 07 series of amendments to this Regulation.**

~~13.3. Acceptance of already issued type approvals~~

~~13.3.1. As from 31 December 2013, Contracting Parties may refuse type approvals granted to this Regulation which do not comply with the requirements mentioned in paragraph 13.2.1. above.~~

~~13.3.2. As from 1 September 2015, Contracting Parties may refuse type approvals of positive ignition engines and vehicles granted to this Regulation, which do not comply with the requirements mentioned in paragraph 13.2.2. above.~~

~~13.3.3. As from 31 December 2016, Contracting Parties may refuse type approvals granted to this Regulation, which do not comply with the requirements mentioned in paragraph 13.2.3. above.~~

~~13.3.4. As from 1 September 2019, type approvals granted to this Regulation as amended by the 06 series of amendments, which do not comply with the requirements of paragraph 13.2.5., shall cease to be valid.~~

**13.3. Reserved**

13.4. Special provisions

13.4.1. Contracting Parties applying this Regulation may continue to grant approvals to those engine systems, or vehicles which comply with any previous series of amendments, or to any level of this Regulation provided that the vehicles are intended for sale or for export to countries that apply the relating requirements in their national legislations.

13.4.2. Replacement engines for vehicles in use

Contracting Parties applying this Regulation may continue to grant approvals to those engines which comply with the requirements of this Regulation as amended by any previous series of amendments, or to any level of this Regulation, provided that the engine is intended as a replacement for a vehicle in-use and for which that earlier standard was applicable at the date of that vehicle's entry into service.

13.4.3. When applying the special provisions described in paragraph 13.4.1. or paragraph 13.4.2., the type approval communication in paragraph 1.6. of the Addendum to Annexes 2A and 2C shall include information relating to these provisions.

13.4.3.1. In the case of approvals to the special provisions laid down in paragraph 13.4.1. the type approval communication shall include the following text at the front-end of the communication, with the relevant number of the series of amendments replacing the "xx" in the example below:

"Engine complying to series of amendments xx of Regulation No. 49".

13.4.3.2. In the case of approvals to the special provisions laid down in paragraph 13.4.2. the type approval communication shall include the following text at the front-end of the communication, with the relevant number of the series of amendments replacing the "xx" in the example below:

"Replacement engine complying to series of amendments xx of Regulation No. 49".

13.4.4. It is appropriate that modified requirements for the in-service testing according to paragraph 9. do not apply retroactively to engines and vehicles which have not been approved in accordance with those requirements. Therefore, vehicles subject to in-service testing according to paragraph 9. shall always be tested according to the provisions set out in the respective level of this Regulation, which has been applicable at the time of type approval."

*Addendum to Annex 2A,*

*Table 6a,* amend the rows concerning Pass Fail Results and add a new footnote to read:

"

Pass Fail Results <sup>3</sup> :	CO	THC	NMHC	CH <sub>4</sub>	NO <sub>x</sub>	PM mass number
Work window conformity factor <sup>4</sup>						
CO <sub>2</sub> mass window conformity factor <sup>4</sup>						

<sup>4</sup> CF<sub>final</sub> needs to be stated, if applicable "

Addendum to Annex 2C,

Table 6a, amend the rows concerning Pass Fail Results and add a new footnote to read:

"

Pass Fail Results <sup>3</sup> :	CO	THC	NMHC	CH <sub>4</sub>	NO <sub>x</sub>	PM <del>mass</del> number
Work window conformity factor <sup>4</sup>						
CO <sub>2</sub> mass window conformity factor <sup>4</sup>						

<sup>4</sup> CF<sub>final</sub> needs to be stated, if applicable "

Insert a new Annex 2D, to read:

## "Annex 2D

### AES Documentation Package

The AES documentation package shall include the following:

**Information on all AES:**

- (a) A declaration of the manufacturer that the engine system or engine family type approved as a separate technical unit, or the vehicle with an approved engine system with regard to emissions, or an vehicle type approved with regard to emissions, does not contain any defeat strategy;
- (b) A description of the engine and the emission control strategies and devices employed, whether software or hardware, and any condition(s) under which the strategies and devices will not operate as they do during testing for Type Approval;
- (c) A declaration of the software versions used to control the AES/BES, including the appropriate checksums of these software versions and instructions to the authority on how to read the checksums; the declaration shall be updated and sent to the approval authority that holds this documentation package each time there is a new software version that has an impact to the AES/BES;
- (d) Detailed technical reasoning of any AES including a risk assessment estimating the risk with and without the AES, and including the following:
  - (i) Information on the hardware element(s) that need to be protected by the AES, where applicable;
  - (ii) Proof of sudden and irreparable engine damage that cannot be prevented by regular maintenance and would occur in the absence of the AES, where applicable;
  - (iii) A reasoned explanation on why there is a need to use an AES upon engine starting or warm up, where applicable;
- (e) A description of the fuel system control logic, timing strategies and switch points during all modes of operation;
- (f) A description of the hierarchical relations among the AES (i.e., when more than one AES can be active concurrently, an indication of which AES is primary in responding, the method by which strategies interact, including data flow diagrams and decision logic and how does the hierarchy assure emissions from all AES are controlled to the lowest practical level;

- (g) A list of parameters which are measured and/or calculated by the AES, along with the purpose of every parameter measured and/or calculated and how each of those parameters relates to engine damage; including the method of calculation and how well these calculated parameters correlate with the true state of the parameter being controlled and any resulting tolerance or factor of safety incorporated into the analysis;
- (h) A list of engine/emission control parameters which are modulated as a function of the measured or calculated parameter(s) and the range of modulation for each engine/emission control parameter; along with the relationship between engine/emission control parameters and measured or calculated parameters;
- (i) An evaluation of how the AES will control real-driving emissions to the lowest practical level, including a detailed analysis of the expected increase of total regulated pollutants and CO<sub>2</sub> emissions by using the AES, compared to the BES;

The AES documentation package shall be limited to 100 pages and shall include all the main elements to allow the approval authority to assess the AES (according to the requirements of Appendix 2 to Annex 10, the effectiveness of the inducement system and the anti-tampering measures. The package may be complemented with annexes and other attached documents, containing additional and complementary elements, if necessary. The manufacturer shall send a new version of the AES documentation package to the approval authority every time changes are introduced to the AES. The new version shall be limited to the changes and their effect. The new version of the AES shall be evaluated and approved by the approval authority.

The AES documentation package shall be structured as follows:

Parts	Paragraph	Point	Explanation
Introduction documents		Introduction letter to Type Approval Authority	Reference of the document with the version, the date of issuing the document, signature by the relevant person in the manufacturer organisation
		Versioning table	Content of each version modifications: and with part is modified
		Description of the (emission) types concerned	
		Attached documents table	List of all attached documents
		Cross references	Link to paragraph (a) to (i) of Annex 2D (where to find each requirement of the regulation)
		Absence of defeat device declaration	+ Signature
Core document	0	Acronyms/abbreviations	
	1	GENERAL DESCRIPTION	
	1.1	Engine general presentation	Description of main characteristics: displacement, after treatment,...
	1.2	General system architecture	System bloc diagram: list of sensors and actuators, explanation of engine general functions
	1.3	Reading of software and calibration version	E.g. scan-tool explanation
	2	Base Emission Strategies	
	2.x	BES x	Description of strategy x
	2.y	BES y	Description of strategy y



	<b>3</b>	<b>Auxiliary Emission Strategies</b>	
	<b>3.0</b>	<b>Presentation of the AESs</b>	<b>Hierarchical relations among AES: description and justification (e.g. safety, reliability, etc.)</b>
	<b>3.x</b>	<b>AES x</b>	<b>3.x.1 AES justification</b> <b>3.x.2 measured and/or modelled parameters for AES characterization</b> <b>3.x.3 Action mode of AES — Parameters used</b> <b>3.x.4 Effect of AES on pollutants and CO<sub>2</sub></b>
	<b>3.y</b>	<b>AES y</b>	<b>3.y.1</b> <b>3.y.2</b> <b>etc.</b>
	<b>4.</b>	<b>Description of the inducement system, including the associated monitoring strategies</b>	
	<b>5.</b>	<b>Description of the anti-tampering measures</b>	
<b>100 page limit ends here</b>			
	<b>Annex</b>		<b>List of types covered by this BES-AES: including Type Approval reference, software reference, calibration number, checksums of each version and of each electronic control unit (engine and/or after-treatment if any)</b>
<b>Attached documents</b>		<b>Technical note for AES justification n°xxx</b>	<b>Risk assessment or justification by testing or example of sudden damage, if any</b>
		<b>Technical note for AES justification n°yyy</b>	
		<b>Test report for specific AES impact quantification</b>	<b>Test report of all specific tests done for AES justification, test conditions details, description of the vehicle/date of the tests emission/CO<sub>2</sub> impact with/without AES activation</b>

"

Annex 3

Table 1 and accompanying notes, amend to read:

" Table 1

**Letters with reference to requirements of OBD and SCR systems**

<i>Character</i>	<i>NO<sub>x</sub> OTL<sup>1</sup></i>	<i>PM OTL<sup>2</sup></i>	<i>CO OTL<sup>6</sup></i>	<i>IUPR<sup>13</sup></i>	<i>Reagent quality</i>	<i>Additional OBD monitors<sup>12</sup></i>	<i>Power threshold requirements<sup>14</sup></i>	<i>Cold start and PM number</i>	<i>Implementation dates: new types</i>	<i>Date when Contracting Parties may refuse type approval</i>
A <sup>9</sup> 10 B <sup>10</sup>	Row "phase-in period" of Tables 1 and 2 of Annex 9A	Performance monitoring <sup>3</sup>	N/A	Phase-in <sup>7</sup>	Phase-in <sup>4</sup>	N/A	20%	N/A	Date of entry into force of 06 series of UN	01 September 2015 <sup>9</sup> 31 December 2016 <sup>10</sup>

									Regulation No. 49	
B <sup>11</sup>	Row "phase-in period" of Tables 1 and 2 of Annex 9A	N/A	Row "phase-in period" of Table 2 of Annex 9A	N/A	Phase-in <sup>4</sup>	N/A	20%	N/A	01 September 2014	31 December 2016
C	Row "general requirements" of Tables 1 and 2 of Annex 9A	Row "general requirements" of Table 1 of Annex 9A	Row "general requirements" of Table 2 of Annex 9A	General <sup>8</sup>	General <sup>5</sup>	Yes	20%	N/A	31 December 2015	01 September 2019
D	Row "general requirements" of Tables 1 and 2 of Annex 9A	Row "general requirements" of Table 1 of Annex 9A	Row "general requirements" of Table 2 of Annex 9A	General <sup>8</sup>	General <sup>5</sup>	Yes	10%	N/A	01 September 2018	31 December 2021
E	Row "general requirements" of Tables 1 and 2 of Annex 9A	Row "general requirements" of Table 1 of Annex 9A	Row "general requirements" of Table 2 of Annex 9A	General <sup>8</sup>	General <sup>5</sup>	Yes	10%	Yes	[Date of entry into force of 07 series of UN Regulation No. 49 <sup>15</sup> ]*	

## Notes:

- <sup>1</sup> "NO<sub>x</sub> OTL" monitoring requirements as set out in Table 1 of Annex 9A for compression ignition and dual-fuel engines and vehicles and in Table 2 of Annex 9A for positive ignition engines and vehicles.
- <sup>2</sup> "PM OTL" monitoring requirements as set out in Table 1 of Annex 9A for compression ignition and dual-fuel engines and vehicles.
- <sup>3</sup> "Performance monitoring" requirements as set out in paragraph 2.3.2.2. of Annex 9A.
- <sup>4</sup> Reagent quality "phase-in" requirements as set out in paragraph 7.1.1.1. of Annex 11.
- <sup>5</sup> Reagent quality "general" requirements as set out in paragraph 7.1.1. of Annex 11.
- <sup>6</sup> "CO OTL" monitoring requirements as set out in Table 2 of Annex 9A for positive ignition engines and vehicles.
- <sup>7</sup> Excluding the statement required by paragraph 6.4.1. of Annex 9A.
- <sup>8</sup> Including the statement required by paragraph 6.4.1. of Annex 9A.
- <sup>9</sup> For positive-ignition engines and vehicles.
- <sup>10</sup> For compression-ignition and dual-fuel engines and vehicles.
- <sup>11</sup> Only applicable to positive-ignition engines and vehicles.
- <sup>12</sup> "Additional provisions concerning monitoring requirements" as set out in paragraph 2.3.1.2. of Annex 9A.
- <sup>13</sup> IUPR specifications are set out in Annexes 9A and 9C of this Regulation. PI engines are not subjected to IUPR."
- <sup>14</sup> ISC requirement set out in Appendix 1 to Annex 8.
- <sup>15</sup> **Subject to transitional measures laid down in paragraph 13.2.2. of this Regulation.**

## Annex 4

Paragraph 8.4.2.3., Equation (36), amend to read:

"...

The following equation shall be applied:

$$m_{\text{gas}} = u_{\text{gas}} \times \sum_{i=1}^{i=n} c_{\text{gas},i} \times q_{\text{mew},i} \times \frac{1}{f} \quad (\text{in g/test})$$

\* To be replaced by actual date of entry into force when known

$$m_{gas} = u_{gas} \times \sum_{i=1}^{i=n} \left( c_{gas,i} \times q_{mew,i} \times \frac{1}{f} \right) \quad \text{in (g/test)} \quad (36)$$

Where:

"..."

Paragraph 8.4.2.4., Equation (37) , amend to read:

"..."

The following equation shall be applied:

$$m_{gas} = \sum_{i=1}^{i=n} u_{gas,i} \times c_{gas,i} \times q_{mew,i} \times \frac{1}{f} \quad \text{(in g/test)}$$

$$m_{gas} = \sum_{i=1}^{i=n} \left( u_{gas,i} \times c_{gas,i} \times q_{mew,i} \times \frac{1}{f} \right) \quad \text{in } \left( \frac{\text{g}}{\text{test}} \right) \quad (37)$$

Where:

"..."

Paragraph 8.5.1.4., Equation (54), amend to read:

"..."

$$Q_{SSV} = \frac{A_0}{60} d_v^2 C_d p_p \sqrt{\left[ \frac{1}{T} (r_p^{1.4286} - r_p^{1.7143}) \cdot \left( \frac{1}{1 - r_p^4 r_p^{1.4286}} \right) \right]} \quad (54)$$

Where:

$$A_0 \quad \text{is } 0.0061110.005692 \text{ in SI units of } \left( \frac{\text{m}^3}{\text{min}} \right) \left( \frac{\text{K}^{\frac{1}{2}}}{\text{kPa}} \right) \left( \frac{1}{\text{mm}^2} \right)$$

$d_v$  is the diameter of the SSV throat, ~~mm~~

"..."

Paragraph 8.5.2.3.1., Equation (57), amend to read:

"..."

$$u_{gas} = \frac{M_{gas}}{M_d \times \left( 1 - \frac{1}{D} \right) + M_e \times \left( \frac{1}{D} \right)} \times \frac{1}{1000} \quad (57)$$

"..."

Paragraph 8.6.1., amend to read:

"..."

Depending on the measurement system and calculation method used, the uncorrected emissions results shall be calculated with equations 36, 37, 56, ~~5758~~ or 62, respectively. For calculation of the corrected emissions,  $c_{gas}$  in equations 36, 37, 56, ~~5758~~ or 62, respectively, shall be replaced with  $c_{cor}$  of equation 66. If instantaneous concentration values  $c_{gas,i}$  are used in the respective equation, the corrected value shall also be applied as instantaneous value  $c_{cor,i}$ . In equations ~~5758 and 62~~, the correction shall be applied to both the measured and the background concentration.

"..."

Paragraph 9.5.4.1., amend to read:

"9.5.4.1. Data analysis

"..."

$$C_d = \frac{Q_{SSV}}{\frac{A_0}{60} \times d_V^2 \times p_p \times \sqrt{\left[ \frac{1}{T} \times (r_p^{1.4286} - r_p^{1.7143}) \times \left( \frac{1}{1 - r_D^4 \times r_p^{1.4286}} \right) \right]}} \quad (89)$$

Where:

$Q_{SSV}$  is the *airflow rate* at standard conditions (101.3 kPa, 273 K), m<sup>3</sup>/s

$T$  is the temperature at the venturi inlet, K

$d_V$  is the diameter of the SSV throat, **mm**

...

$$Re = A_1 \times 60 \times \frac{Q_{SSV}}{d_V \times \mu} \quad (90)$$

With

$$\mu = \frac{b \times T^{1.5}}{S + T} \quad (91)$$

Where:

$A_1$  is ~~25.55152~~ **27.43831** in SI units of  $\left(\frac{kg^{\frac{1}{3}}}{m^3}\right) \left(\frac{min}{s}\right) \left(\frac{mm}{m}\right)$

$Q_{SSV}$  is the *airflow rate* at standard conditions (101.3 kPa, 273 K), m<sup>3</sup>/s

$d_V$  is the *diameter* of the SSV throat, **mm**

..."

Annex 4 Appendix 2

Paragraph A.2.1.3., amend to read:

"A.2.1.3. Components of Figures 9 and 10

EP Exhaust pipe

**SPSP1** Raw exhaust gas sampling probe (Figure 9 only)

..."

Paragraph A.2.2.1., amend to read:

"...

Figure 12

**Scheme of partial flow dilution system (total sampling type)**

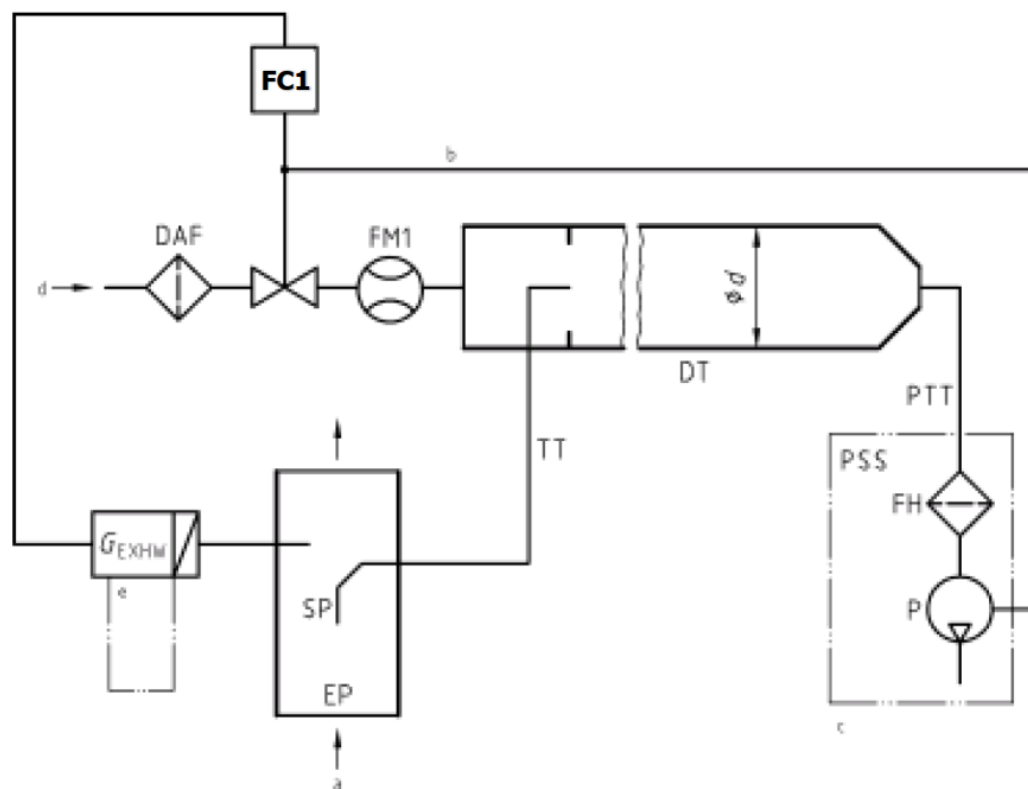
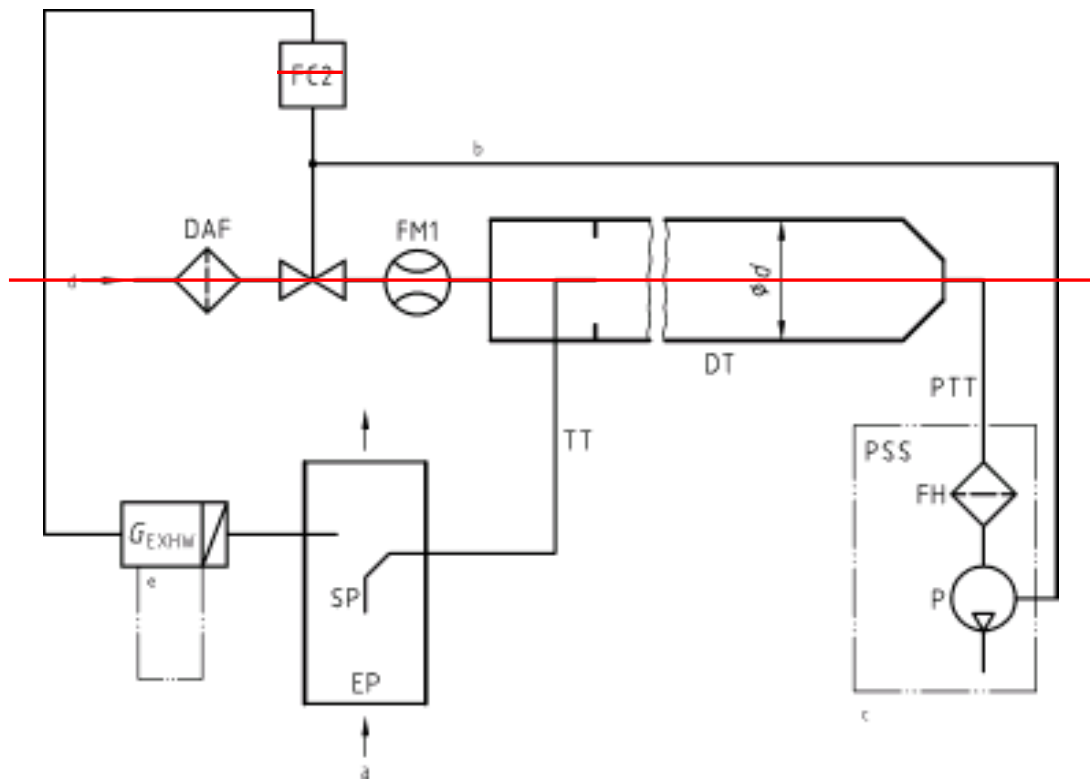

a = exhaust

b = optional

c = details see Figure 16

..."

Paragraph A.2.2.5., amend to read:

"...

For a partial flow dilution system, a sample of the diluted exhaust gas is taken from the dilution tunnel DT through the particulate sampling probe PSP and the particulate transfer tube PTT by means of the sampling pump P, as shown in Figure 16. The sample is passed through the filter holder(s) FH that contain the particulate sampling filters. The sample flow rate is controlled by the flow controller ~~FC3FC2~~.

For of full flow dilution system, a double dilution particulate sampling system shall be used, as shown in Figure 17. A sample of the diluted exhaust gas is transferred from the dilution tunnel DT through the particulate sampling probe PSP and the particulate transfer tube PTT to the secondary dilution tunnel SDT, where it is diluted once more. The sample is then passed through the filter holder(s) FH that contain the particulate sampling filters. The diluent flow rate is usually constant whereas the sample flow rate is controlled by the flow controller ~~FC3FC2~~. If electronic flow compensation EFC (see Figure 15) is used, the total diluted exhaust gas flow is used as command signal for ~~FC3FC2~~.

..."

Annex 8

Paragraph 4.1., amend to read:

"4.1. Vehicle payload

Normal payload is a payload between 10 and 100 per cent of the maximum payload.

The maximum payload is the difference between technically permissible maximum laden mass of the vehicle and the mass of the vehicle in running order as specified in Annex 3 to Special Resolution No. 1 (ECE/TRANS/WP.29/1045, as amended by Amendments 1 and 2).

**In case the legally permissible maximum vehicle weight is lower than the technically permissible laden mass of the vehicle, it is permitted to use the legally permissible maximum vehicle weight to determine the vehicle payload for the test run.**

For the purpose of in- service conformity testing the payload may be reproduced and an artificial load may be used.

Approval authorities may request to test the vehicle with any payload between 10 to 100 per cent of the maximum vehicle payload. In case the mass of the PEMS equipment needed for operation exceeds 10 per cent of the maximum vehicle payload this mass may be considered as minimum payload."

Paragraph 4.6.2., amend to read:

"4.6.2. ~~Emissions and other data sampling shall start prior to starting the engine. Any cold start emissions may be removed from the emissions evaluation, in accordance with paragraph A.1.2.6. of Appendix 1 to this annex.~~ **Emissions and other data sampling shall start prior to starting the engine. Cold start emissions shall be included in the emissions evaluation, in accordance with paragraph A.1.2.6. of Appendix 1 to this annex.**"

Paragraph 6.3., including Table 2, amend to read:

"6.3. ~~The 90 per cent cumulative percentile of the exhaust emission conformity factors from each engine system tested, determined in accordance with the measurement and calculation procedures specified in Appendix 1 to this annex, shall not exceed any of the values set out in Table 2.~~ **The final conformity factor for the test (CF<sub>final</sub>) for each pollutant calculated in accordance with**

**Appendix 1 shall not exceed the maximum allowed conformity factor for that pollutant set out in Table 2.**

Table 2

**Maximum allowed conformity factors for in-service conformity emission testing**

<i>Pollutant</i>	<i>Maximum allowed conformity factor</i>
CO	1.50
THC <sup>1</sup>	1.50
NMHC <sup>2</sup>	1.50
CH <sub>4</sub> <sup>2</sup>	1.50
NO <sub>x</sub>	1.50
PM mass	-
PM number	<b>1.63<sup>3</sup>-</b>

<sup>1</sup> For compression-ignition engines.

<sup>2</sup> For positive-ignition engines.

<sup>3</sup> Subject to transitional provisions laid down in paragraph 13.2. of this Regulation.

*Insert a new paragraph 10.1.8.5a., to read:*

**"10.1.8.5a. PM number concentration [#/cm<sup>3</sup>]"**

*Insert a new paragraph 10.1.9.5a., to read:*

**"10.1.9.5a. PM number flux [#/s]"**

*Insert a new paragraph 10.1.9.10a., to read:*

**"10.1.9.10a. PM number [#]"**

*Insert a new paragraph 10.1.9.19a., to read:*

**"10.1.9.19a. Work window PM number conformity factor [-]"**

*Insert a new paragraph 10.1.9.24a., to read:*

**"10.1.9.24a. CO<sub>2</sub> mass window PM number conformity factor [-]"**

*Insert a new paragraph 10.1.10.12a., to read:*

**"10.1.10.12a. PM number [#]"**

*Insert a new paragraph 10.1.11.5a., to read:*

**"10.1.11.5a. Work window PM number conformity factor [-]"**

*Insert a new paragraph 10.1.11.9a., to read:*

**"10.1.11.9a. CO<sub>2</sub> mass window PM number conformity factor [-]"**

*Insert a new paragraph 10.1.12.4a., to read:*

**"10.1.12.4a. PM number analyser zero, pre and post test"**

*Annex 8, Appendix 1*

*Paragraph A.1.1., amend to read:*

"A.1.1. Introduction

~~This appendix describes the procedure to determine gaseous emissions from on vehicle on road measurements using Portable Emissions Measurement Systems (hereinafter PEMS). The pollutant emissions to be measured from the exhaust of the engine include the following components: carbon monoxide,~~

~~total hydrocarbons and nitrogen oxides for compression ignition engines and carbon monoxide, non-methane hydrocarbons, methane and nitrogen oxides for positive ignition engines. Additionally, carbon dioxide shall be measured to enable the calculation procedures described in paragraph A.1.4.~~ **This Appendix describes the procedure to determine pollutant emissions from on-vehicle on-road measurements using Portable Emissions Measurement Systems (hereinafter “PEMS”). The pollutant emissions to be measured from the exhaust of the engine include the following components: carbon monoxide, total hydrocarbons, nitrogen oxides and PM number for compression ignition engines and carbon monoxide, non-methane hydrocarbons, methane, nitrogen oxides and PM number for positive ignition engines. Additionally, carbon dioxide shall be measured to enable the calculation procedures described in paragraph A.1.4.**

For engines fuelled with natural gas, the manufacturer, technical service or Type Approval Authority may choose to measure the total hydrocarbon (THC) emissions only instead of measuring the methane and non-methane hydrocarbon emissions. In that case, the emission limit for the total hydrocarbon emissions is the same as the one shown in paragraph 5.3. of this Regulation for methane emissions. For the purposes of the calculation of the conformity factors pursuant to paragraphs A.1.4.2.3. and A.1.4.3.2., the applicable limit shall in that case be the methane emission limit only.

For engines fuelled with gases other than natural gas, the manufacturer, technical service or Type Approval Authority may choose to measure the total hydrocarbon (THC) emissions instead of measuring the non-methane hydrocarbon emissions. In that case, the emission limit for the total hydrocarbon emissions is the same as shown in paragraph 5.3. of this Regulation for non-methane hydrocarbon emissions. For the purposes of the calculations of the conformity factors pursuant to paragraphs A.1.4.2.3. and A.1.4.3.2., the applicable limit shall in that case be the non-methane emission limit."

*Paragraph A.1.2.1.1., amend to read:*

"A.1.2.1.1. ~~Gas analysers to measure the concentrations of regulated gaseous pollutants in the exhaust gas~~ **Gas analysers and PM number analysers to measure the concentrations of regulated pollutants in the exhaust gas;**"

*Table 1 in paragraph A.1.2.2., amend to read:*

"Table 1

**Test parameters**

<i>Parameter</i>	<i>Unit</i>	<i>Source</i>
THC concentration <sup>1</sup>	ppm	<del>Analyzer</del> <b>Gas analyser</b>
CO concentration <sup>1</sup>	ppm	<del>Analyzer</del> <b>Gas analyser</b>
NO <sub>x</sub> concentration <sup>1</sup>	ppm	<del>Analyzer</del> <b>Gas analyser</b>
CO <sub>2</sub> concentration <sup>1</sup>	ppm	<del>Analyzer</del> <b>Gas analyser</b>
CH <sub>4</sub> concentration <sup>1, 2</sup>	ppm	<del>Analyzer</del> <b>Gas analyser</b>
<b>PM number concentration</b>	<b>#/cm<sup>3</sup></b>	<b>PM number analyser</b>
<b>Dilution setting (if applicable)</b>	-	<b>PM number analyser</b>



<i>Parameter</i>	<i>Unit</i>	<i>Source</i>
Exhaust gas flow	kg/h	Exhaust Flow Meter (hereinafter EFM)
Exhaust temperature	°K	EFM
Ambient temperature <sup>3</sup>	°K	Sensor
Ambient pressure	kPa	Sensor
Engine torque <sup>4</sup>	Nm	ECU or Sensor
Engine speed	rpm	ECU or Sensor
Engine fuel flow	g/s	ECU or Sensor
Engine coolant temperature	°K	ECU or Sensor
Engine intake air temperature <sup>3</sup>	°K	Sensor
Vehicle ground speed	km/h	ECU and GPS
Vehicle latitude	degree	GPS
Vehicle longitude	degree	GPS

*Notes:*

<sup>1</sup> Measured or corrected to a wet basis

<sup>2</sup> Only for gas engines fuelled with natural gas

<sup>3</sup> Use the ambient temperature sensor or an intake air temperature sensor

<sup>4</sup> The recorded value shall be either (a) the net brake engine torque according to paragraph A.1.2.4.4. of this appendix or (b) the net brake engine torque calculated from the torque values according to paragraph A.1.2.4.4. of this appendix.

*Insert new paragraphs A.1.2.4.6. and A.1.2.4.7., to read:*

**"A.1.2.4.6. Installation of PM number analyser**

**The installation and operation of the PEMS shall be leak-tight and minimise heat loss. To avoid the generation of particles, connectors shall be thermally stable at the exhaust gas temperatures expected during the test. Where elastomer connectors are used to connect the vehicle exhaust outlet and the connecting tube, those connectors shall have no contact with the exhaust gas to avoid artefacts at high engine load.**

**A.1.2.4.7. Sampling of PM number emissions**

**Emissions sampling shall be representative and conducted at locations of well-mixed exhaust gas where the influence of ambient air downstream of the sampling point is minimal. Where applicable, emissions shall be sampled downstream of the exhaust mass flow meter, respecting a distance of at least 150 mm to the flow sensing element. The sampling probe shall be fitted at least 3 times the inner diameter of the exhaust pipe upstream of the point at which the exhaust exits into the environment. The exhaust shall be sampled from the centre of the exhaust stream. Where several probes are used for emissions sampling, the particle sampling probe shall be placed upstream of the other sampling probes. The particle sampling probe shall not interfere with the sampling of gaseous pollutants. The type and specifications of the probe and its mounting shall be documented in detail, either in the test report of the Technical Service (in the case of testing at type approval) or in the vehicle manufacturer's own documentation (in case of in-service conformity testing).**

Where particles are sampled and not diluted at the tailpipe, the sampling line from the raw exhaust sample point to the point of dilution or particle detector shall be heated to a minimum of 373 K (100 °C).

All parts of the sampling system, from the exhaust pipe to the particle detector, which are in contact with raw or diluted exhaust gas, shall be designed to minimise the deposition of particles. All parts shall be made from anti-static material to prevent electrostatic effects."

*Insert a new paragraph A.1.2.5.5., to read:*

**"A.1.2.5.5. Checking the PM number analyser**

The PEMS shall function free of errors and critical warnings. The zero level of the PM number analyser shall be recorded by sampling high efficiency particulate filtered ambient air (HEPA) at the inlet of the sampling line in the 12 hour-period before test start. The signal shall be recorded at a constant frequency of at least 1.0 Hz averaged over a period of 2 minutes. The final absolute concentration shall be within the manufacturer's specifications and, in addition, shall not exceed 5,000 particles per cubic centimetre."

*Paragraph A.1.2.6.1., amend to read:*

**"A.1.2.6.1. Test start**

~~Emissions sampling, measurement of the exhaust parameters and recording of the engine and ambient data shall commence prior to starting the engine. The coolant temperature shall not exceed 303 K (30 °C) at the beginning of the test. In case ambient temperature exceeds 303 K (30 °C) at the beginning of the test, the coolant temperature shall not exceed the ambient temperature by more than 2 °C. The data evaluation shall start after the coolant temperature has reached 343 K (70 °C) for the first time or after the coolant temperature is stabilized within +/- 2 K over a period of 5 minutes whichever comes first but no later than 15 minutes after engine start.~~

**For the purposes of the test procedure, "test start" shall mean the first ignition of the internal combustion engine.**

**Emissions sampling, measurement of the exhaust parameters and recording of the engine and ambient data shall commence prior to the test start. Artificial warming up of the emission control systems of the vehicle prior to the test start shall be prohibited.**

**At test start, the temperature of the coolant shall not exceed the ambient temperature by more than 5 °C, and shall not exceed 303 K (30 °C). The data evaluation shall start once the coolant temperature has reached 303 K (30 °C) for the first time or once the coolant temperature is stabilised within +/- 2 K over a period of 5 minutes, whichever occurs first, but in any event no later than 10 minutes after test start."**

*Paragraph A.1.2.6.3., amend to read:*

**"A.1.2.6.3. End of test sequence**

~~At the end of the test, sufficient time shall be given to the sampling systems to allow their response times to elapse. The engine may be shut down before or after sampling is stopped.~~

**Test end**

**Test end is reached when the vehicle has completed the trip and the internal combustion engine is switched off.**

**The internal combustion engine shall be switched off as soon as practicable at the end of the trip. Data shall continue to be recorded until the response time of the sampling systems has elapsed."**

Paragraph A.1.2.7.4.(a), amend to read:

- "(a) ~~If the difference between the pre-test and post-test results is less than 2 per cent as specified in paragraphs A.1.2.7.2. and A.1.2.7.3., the measured concentrations may be used uncorrected or may be corrected for drift according to paragraph A.1.2.7.5.~~ **If the difference between the pre-test and post-test results is less than 2 % as specified in paragraphs A.1.2.7.2 and A.1.2.7.3, the measured concentrations may be used uncorrected or shall, at the request of the manufacturer, be corrected for drift according to paragraph A.1.2.7.5.;**"

Insert a new paragraph A.1.2.7.6., to read:

**"A.1.2.7.6. Checking the PM number analyser**

**The zero level of the PM number analyser shall be checked before test start and after test end and recorded in accordance with the requirements of paragraph A.1.2.5.5. "**

Paragraphs A.1.3.1.1., A.1.3.1.2. and A.1.3.1.3., amend to read:

~~"A.1.3.1.1. Gas analysers data~~

~~The data from the gas analysers shall be properly aligned using the procedure in paragraph 9.3.5. of Annex 4.~~

~~A.1.3.1.2. Gas analysers and EFM data~~

~~The data from the gas analysers shall be properly aligned with the data of the EFM using the procedure in paragraph A.1.3.1.4.~~

~~A.1.3.1.3. PEMS and engine data~~

~~The data from the PEMS (gas analysers and EFM) shall be properly aligned with the data from the engine ECU using the procedure in paragraph A.1.3.1.4.~~

**A.1.3.1.1. Analysers data**

**The data from the gas analysers shall be properly aligned using the procedure laid down in paragraph 9.3.5. of Annex 4. The data from the PM number analyser shall be time aligned with its own transformation time, according to the instrument manufacturer's instructions.**

**A.1.3.1.2. Analysers and Exhaust Flow Meter (EFM) data**

**The data from the gas analysers and the PM number analysers shall be properly aligned with the data of the EFM using the procedure in paragraph A.1.3.1.4.**

**A.1.3.1.3. PEMS and engine data**

**The data from the PEMS (gas analysers, PM number analyser and EFM) shall be properly aligned with the data from the engine ECU using the procedure in paragraph A.1.3.1.4."**

Paragraph A.1.3.1.4., amend to read:

"A.1.3.1.4. Procedure for improved time-alignment of the PEMS data

The test data listed in Table 1 are split into 3 different categories:

1. ~~Gas analysers (THC, when applicable CH<sub>4</sub>, CO, CO<sub>2</sub>, NO<sub>x</sub> concentrations)~~ **Gas analysers (THC, CO, CO<sub>2</sub>, NO<sub>x</sub> concentrations) and PM number analyser;**
2. Exhaust Flow Meter (Exhaust mass flow and exhaust temperature);
3. Engine (Torque, speed, temperatures, fuel rate, vehicle speed from ECU).

The time alignment of each category with the other categories shall be verified by finding the highest correlation coefficient between two series of parameters. All the parameters in a category shall be shifted to maximize the correlation factor. The following parameters shall be used to calculate the correlation coefficients:

To time-align:

- (a) Categories 1 and 2 (Analyzers and EFM data) with category 3 (Engine data): the vehicle speed from the GPS and from the ECU;
- (b) Category 1 with category 2: the CO<sub>2</sub> concentration and the exhaust mass;
- (c) Category 2 with category 3: the CO<sub>2</sub> concentration and the engine fuel flow."

Add a new paragraph A.1.3.6., to read:

**"A.1.3.6. Calculation of the instantaneous PM number emissions**

**The instantaneous PM number (PN<sub>i</sub>) emissions (#/s) shall be determined by multiplying the instantaneous concentration of the PM number (#/cm<sup>3</sup>) with the instantaneous exhaust mass flow rate (kg/s), both corrected and aligned for the transformation time, according to paragraph A.3.1.4.3. of Appendix 3. All negative instantaneous emissions values shall enter subsequent data evaluations as zero. All significant digits of intermediate results shall enter the calculation of the instantaneous emissions. The following formula shall apply for the purposes of determining the instantaneous PM number emissions:**

$$PN_i = c_{PNi} \times q_{mewi} / \rho_e$$

where:

- PN<sub>i</sub>** is the instantaneous PM number emissions, #/s
- c<sub>PNi</sub>** is the measured PM number concentration, #/m<sup>3</sup> normalised at 273 K (0 °C) including internal dilution and particle losses
- q<sub>mewi</sub>** is the measured exhaust mass flow rate, kg/s
- ρ<sub>e</sub>** is the density of the exhaust gas, kg/m<sup>3</sup> at 273 K (0 °C)."

Paragraphs A.1.4.2.1. and A.1.4.2.1.1., amend to read:

~~"A.1.4.2.1. Calculation of the specific emissions~~

~~The specific emissions  $e_{gas}$  (mg/kWh) shall be calculated for each window and each pollutant in the following way:~~

$$e_{gas} = \frac{m}{W(t_{2,i}) - W(t_{1,i})}$$

~~Where:~~

~~$m$  is the mass emission of the component, mg/window~~

~~$W(t_{2,i}) - W(t_{1,i})$  is the engine work during the  $i^{\text{th}}$  averaging window, kWh~~

~~A.1.4.2.1.1. Calculation of the specific emissions for a declared market fuel~~

~~If a test according to this Annex was performed with a market fuel declared in paragraph 3.2.2.2.1. of Part 1 of Annex 1 to this Regulation and a power correction factor in accordance with paragraph 3.2.2.2.2. of Part 1 of Annex 1 to this Regulation was documented for the market fuel used for the test, the specific emissions  $e_{gas}$  (mg/kWh) shall be calculated for each window and each pollutant by multiplication of the specific emissions with the declared power correction factor.~~

**A.1.4.2.1. Calculation of the specific emissions**

The specific emissions  $e$  (mg/kWh or #/kWh) shall be calculated for each window and each pollutant in the following way:

$$e = \frac{m}{W(t_{2,i}) - W(t_{1,i})}$$

where:

$m$  is the mass emission of the pollutant, mg/window, or the PM number, #/window

$W(t_{2,i}) - W(t_{1,i})$  is the engine work during the  $i^{\text{th}}$  averaging window, kWh.

**A.1.4.2.1.1. Calculation of the specific emissions for a declared market fuel**

If a test pursuant to this annex was performed with a market fuel declared in paragraph 3.2.2.2.1. of Part 1 of Annex 1, the specific emissions  $e$  (mg/kWh or #/kWh) shall be calculated for each window and each pollutant by multiplying the specific emissions determined in accordance with paragraph A.1.4.2.1. with the power correction factor determined pursuant to paragraph 4.6.2.(b) of this Regulation."

Paragraph A.1.4.2.3., amend to read:

**"A.1.4.2.3. Calculation of the conformity factors**

The conformity factors shall be calculated for each individual valid window and each individual pollutant in the following way:

$$CF = \frac{e}{L}$$

Where:

$e$  is the brake specific emission of the component, mg/kWh;

$L$  is the applicable limit, mg/kWh.

$e$  is the brake-specific emission of the gaseous pollutant, mg/kWh or #/kWh;

$L$  is the applicable limit, mg/kWh or #/kWh.

Paragraph A.1.4.3.2., amend to read:

**"A.1.4.3.2. Calculation of the conformity factors**

The conformity factors shall be calculated for each individual window and each individual pollutant in the following way:

$$CF = \frac{CF_I}{CF_C}$$

Where

$$CF_I = \frac{m}{m_{CO_2}(t_{2,i}) - m_{CO_2}(t_{1,i})} \quad (\text{in service ratio) and}$$

$$CF_C = \frac{m_L}{m_{CO_2,ref}} \quad (\text{certification ratio)}$$

Where:

$m$	is the mass emission of the component, mg/window <b>gaseous pollutant, mg/window, or the PM number, #/window;</b>
$m_{CO_2}(t_{2,i}) - m_{CO_2}(t_{1,i})$	is the CO <sub>2</sub> mass during the i <sup>th</sup> averaging window, kg;
$m_{CO_2,ref}$	is the engine CO <sub>2</sub> mass determined for the WHTC, kg;
$m_L$	<del>is the mass emission of the component corresponding to the applicable limit on the WHTC, mg;</del> <b>is the mass emission of the gaseous pollutant or the PM number corresponding to the applicable limit on the WHTC, mg or # respectively.</b>

Add new paragraphs A.1.4.4. and A.1.4.4.1., to read:

**"A.1.4.4. Calculation of the final conformity factor for the test**

**A.1.4.4.1. The final conformity factor for the test ( $CF_{final}$ ) for each pollutant shall be calculated as follows:**

$$CF_{final} = 0.14 \times CF_{cold} + 0.86 \times CF_{warm}$$

where:

$CF_{cold}$  **is the conformity factor of the period of cold operation of the test, which shall be equal to the highest conformity factor of the moving averaging windows starting below 343 K (70 °C) coolant temperature, determined for that pollutant in accordance with the calculation procedures specified in paragraphs A.1.4.1. and either A.1.4.2. or, as applicable, A.1.4.3.;**

$CF_{warm}$  **is the conformity factor of the period of warm operation of the test, which shall be equal to the 90th cumulative percentile of the conformity factors determined for that pollutant in accordance with the calculation procedures specified in paragraphs A.1.4.1 and either A.1.4.2. or, as applicable, A.1.4.3., when the data evaluation is started after the coolant temperature has reached 343 K (70 °C) for the first time.**

*Annex 8, Appendix 2*

*Paragraph A.2.1., amend to read:*

"A.2.1. General

~~The gaseous emissions shall be measured according to the procedure set out in Appendix 1 to this annex. The present appendix describes the characteristics of the portable measurement equipment that shall be used to perform such tests.~~  
**The gaseous emissions and the PM number shall be measured according to the procedure set out in Appendix 1. The present appendix describes the characteristics of the portable measurement equipment that shall be used to perform such measurement tests."**

*Add a new paragraph A.2.2.5., to read:*

**"A.2.2.5. PM number analysers**

**A.2.2.5.1. General**

**A.2.2.5.1.1. The PM number analyser shall consist of a pre-conditioning unit and a particle detector (see Figure 1). The particle detector may also pre-condition the aerosol. The analyser's sensitivity to shocks, vibrations, aging, variations in temperature and air pressure, electromagnetic interferences and other things that could affect the operation of the vehicle or the analyser shall be kept to a minimum as far as possible and shall be clearly stated in the supporting documentation produced by the instrument manufacturer. The PM number analyser shall fulfil the requirements of this Regulation and the specifications of the instrument manufacturer.**

**Figure 1**  
**Example of a PM number analyser setup**

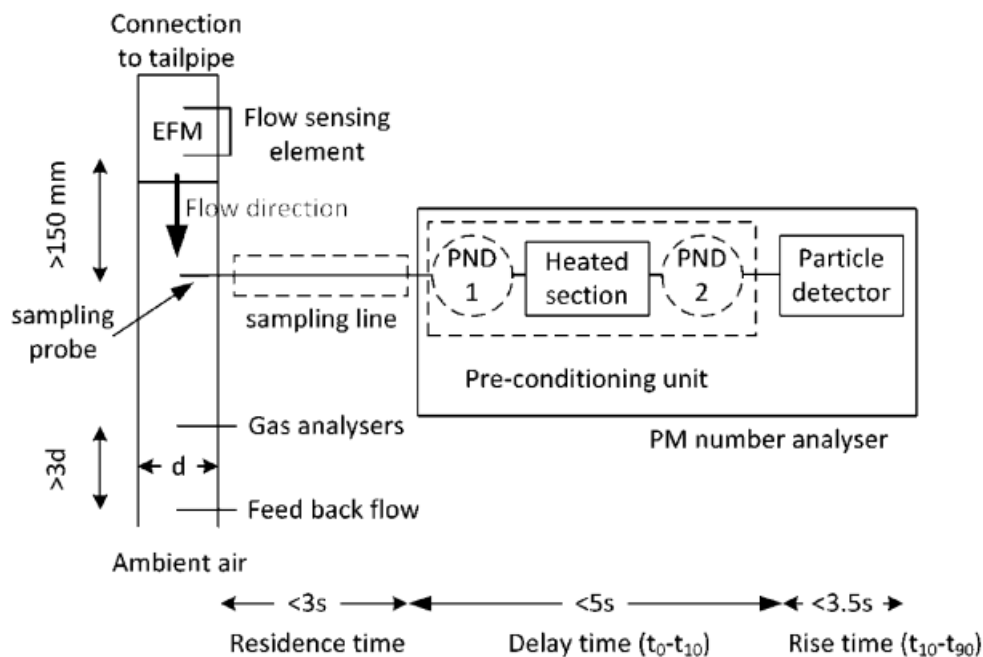

**Notes:** dotted lines depict optional parts; EFM means Exhaust mass Flow Meter; d means inner diameter ; PND means PM Number Diluter

- A.2.2.5.1.2. The PM number analyser shall be connected to the sampling point via a sampling probe which extracts a sample from the centreline of the tailpipe tube. If particles are not diluted at the tailpipe, the sampling line shall be heated to a minimum temperature of 373 K (100 °C) until the point of first dilution of the PM number analyser or the particle detector of the analyser. The residence time of the sample in the particle sampling line shall be less than 3 seconds to the point of first dilution or to the particle detector.
- A.2.2.5.1.3. All parts in contact with the sampled exhaust gas shall be always kept at a temperature that avoids condensation of any compound in the device. That may be achieved e.g. by heating to a higher temperature and diluting the sample or oxidising the (semi)volatile species.
- A.2.2.5.1.4. The PM number analyser shall include a heated section at wall temperature  $\geq 573\text{K}$  (300 °C). The pre-conditioning unit shall control the heated stages to constant nominal operating temperatures, within a tolerance of  $\pm 10\text{K}$  and provide an indication of whether or not heated parts are at their correct operating temperatures. Lower temperatures are acceptable as long as the volatile particle removal efficiency meets the specifications set out in paragraph A.2.2.5.4.
- A.2.2.5.1.5. Pressure, temperature and other sensors shall monitor the operation of the instrument during its operation and shall trigger a warning or message in case of malfunction.
- A.2.2.5.1.6. The delay time inside the PM number analyser shall be  $< 5\text{ s}$ . Delay time means the time difference between a change of concentration at the reference point and a system response of 10 per cent of the final reading.
- A.2.2.5.1.7. The PM number analyser (and/or particle detector) shall have a rise time of  $< 3.5\text{ s}$ .
- A.2.2.5.1.8. Particle concentration measurements shall be reported normalised to 273 K (0 °C) and 101.3 kPa. If considered necessary using best engineering judgement, the pressure and/or temperature at the inlet of the detector shall be



measured and reported for the purposes of normalising the particle concentration.

A.2.2.5.1.9. PM number analysers that comply with the calibration requirements of UN Regulation No. 83 or UN Regulation No. [154] shall be deemed to comply with the calibration requirements of this annex.

#### A.2.2.5.2. Efficiency requirements

A.2.2.5.2.1. The complete PM number analyser system and the sampling line, shall meet the efficiency requirements of Table 1:

**Table 1**  
PM number analyser system (and sampling line) efficiency requirements

dp [nm]	sub-23	23	30	50	70	100	200
E(dp)	- (*)	0.2-0.6	0.3-1.2	0.6-1.3	0.7-1.3	0.7-1.3	0.5-2.0

(\*) Will be defined at a later stage

A.2.2.5.2.2. Efficiency E(dp) is the ratio in the readings of the PM number analyser system to a reference Condensation Particle Counter (CPC)'s (d50 = 10 nm or lower, checked for linearity and calibrated with an electrometer) or an Electrometer's number concentration measuring in parallel monodisperse aerosol of mobility diameter dp and normalised at the same temperature and pressure conditions. The material shall be thermally stable and soot-like (e.g. spark discharged graphite or diffusion flame soot with thermal pre-treatment). If the efficiency curve is measured with a different aerosol (e.g. NaCl), the correlation to the soot-like curve shall be provided in the form of a chart which compares the efficiencies obtained using both test aerosols. The differences in the counting efficiencies shall be taken into account by adjusting the measured efficiencies based on that comparison chart to give soot-like aerosol efficiencies. Any correction for multiple charged particles shall be applied and documented, but it shall not exceed 10 per cent. The final efficiencies (e.g. adjusted for the different material and multiple charged particles) shall cover the PM number analyser and sampling line. The PM number analyser may alternatively be calibrated in parts (i.e. the pre-conditioning unit separately from the particle detector) provided that the PM number analyser and the sampling line together meet the requirements of Table 1. The signal measured from the detector shall be > 2 times the limit of detection (here defined as the zero level plus 3 standard deviations).

#### A.2.2.5.3. Linearity requirements

A.2.2.5.3.1. The linearity requirements shall be verified whenever damage is observed, as required by internal audit procedures or by the instrument manufacturer, at least once within the 12-month period leading up to a test.

A.2.2.5.3.2. The PM number analyser, and the sampling line, shall meet the linearity requirements set out in Table 2.

**Table 2**  
Linearity requirements of PM number analyser (and the sampling line)

Measurement parameter/instrument	$ \chi_{min} \times (a_1 - 1) + a_0 $	Slope $a_1$	Standard error SEE	Coefficient of determination $r^2$
PM number analyser	≤ 5 per cent max	0.85-1.15	≤ 10 per cent max	≥ 0.950

- A.2.2.5.3.3.** The PM number analyser system and the sampling line, shall meet the linearity requirements of Table 2 using monodisperse or polydisperse soot-like particles. The particle size (mobility diameter or count median diameter) shall be larger than 45 nm. The reference instrument shall be an Electrometer or a Condensation Particle Counter (CPC) with  $d_{50} = 10$  nm or lower, verified for linearity. Alternatively, the reference instrument may be a particle number system that complies with the requirements of paragraph 10. of Annex 4.
- A.2.2.5.3.4.** In addition, the differences between the PM number analyser and the reference instrument at each of the points that are checked (except the zero point) shall be within 15 per cent of their mean value. At least 5 points equally distributed (plus the zero point) shall be checked. The maximum checked concentration shall be the maximum allowed concentration of the PM number analyser. If the PM number analyser is calibrated in parts, the linearity may be checked only for the detector, but the efficiencies of the other parts and the sampling line shall be taken into account in the slope calculation.
- A.2.2.5.4.** Volatile removal efficiency
- A.2.2.5.4.1.** The PM number analyser system shall achieve > 99 per cent removal of  $\geq 30$  nm tetracontane ( $\text{CH}_3(\text{CH}_2)_{38}\text{CH}_3$ ) particles with an inlet concentration of  $\geq 10,000$  particles per cubic centimetre at the minimum dilution.
- A.2.2.5.4.2.** Additionally, the PM number analyser system shall also achieve a > 99 per cent removal efficiency of polydisperse alkane (decane or higher) or emery oil with count median diameter > 50 nm and an inlet concentration of  $\geq 5 \times 10^6$  particles per cubic centimetre at the minimum dilution (equivalent mass > 1  $\text{mg}/\text{m}^3$ ).
- A.2.2.5.4.3.** The volatile removal efficiency with tetracontane and/or polydisperse alkane or oil need to be proven only once for the PEMS family. A PEMS family is considered to be a group of instruments with the same analysers, sample and thermal conditioning and software compensation algorithms. The instrument manufacturer shall provide the maintenance or replacement interval that ensures that the removal efficiency does not drop below the technical requirements. If such information is not provided by the instrument manufacturer, the volatile removal efficiency shall be checked yearly for each instrument."

*Annex 8, Appendix 3*

*Add a new paragraph A.3.1.4. to read:*

- "A.3.1.4.** PM number analyser calibration and verification
- A.3.1.4.1.** The PEMS leakage test shall be conducted either in accordance with the requirements set out in paragraph 9.3.4. of Annex 4 or in accordance with the instrument manufacturer's instructions.
- A.3.1.4.2.** The response time check of the PM number analyser shall be conducted in accordance with the requirements set out in paragraph 9.3.5. of Annex 4 using particles if gases cannot be used.
- A.3.1.4.3.** The transformation time of the PM number analyser system and its sampling line, shall be determined in accordance with paragraph A.8.1.3.7. of Appendix 8 to Annex 4. "Transformation time" means the time difference between a change of concentration at the reference point and a system response of 50 per cent of the final reading.

*Annex 9A*

*Paragraph 2.4.1., amend to read:*

"2.4.1. If requested by the manufacturer, for vehicles of categories M<sub>2</sub> and N<sub>1</sub>, for vehicles of categories M<sub>1</sub> and N<sub>2</sub> with a technically permissible maximum laden mass not exceeding 7.5 tonnes, and for vehicles of category M<sub>3</sub> Class I, Class II and Classes A and B<sup>†</sup> with a permissible mass not exceeding 7.5 tonnes, compliance with the requirements of Annex 11 to the 07 series of amendments to UN Regulation No. 83 **or compliance with the requirements of Annex C5 of UN Regulation No. [154]** shall be considered equivalent to the compliance with this annex, according to the following equivalences."

*Add a new paragraph 2.4.1.4., to read:*

**"2.4.1.4. The OBD standard "Final OBD threshold limits" in Table 4A of UN Regulation No. [154] shall be considered as equivalent to the character E of the Table 1 of Annex 3 to this Regulation."**

*Insert a new paragraph 2.4.1.5. and renumber and amend paragraphs 2.4.1.3.1. to 2.4.1.3.2.2., to read:*

2.4.1.5. Special requirements for alternative approvals

**2.4.1.3.1-2.4.1.5.1.** If such alternative approval is used, the information related to OBD systems in paragraph 3.2.12.2.7. of Part 2 of Annex 1 is replaced by the information of paragraph 3.2.12.2.7. of Annex 1 to the 07 series of amendments to UN Regulation No. 83 **or by the information of paragraph 3.2.12.2.7. of Annex A1 to Regulation No. [154].**

**2.4.1.3.2-2.4.1.5.2.** The equivalences set out in paragraph 2.4.1. shall apply in the following manner:

**2.4.1.3.2.1-2.4.1.5.2.1.** The OTL's and dates referred to in Table 1 of Annex 3 to this Regulation and relevant to the assigned character for which the type-approval is sought shall apply;

**2.4.1.3.2.2-2.4.1.5.2.2.** The requirements on NO<sub>x</sub> control measures described in paragraphs 2.1.2.2.1. to 2.1.2.2.4. of Annex 11 shall apply.

*Annex 10*

*Paragraph 11., add a new sub-paragraph at the end, to read:*

**"The methodology for the assessment of AES is described in Appendix 2 to this annex."**

*Annex 10, Appendix 1*

*Paragraph A.1.3.1., amend to read:*

"A.1.3.1. Vehicle payload

For the purpose of the PEMS demonstration test, the payload may be reproduced and an artificial load may be used.

~~The vehicle payload shall be 50-60 per cent of the maximum vehicle payload. The additional requirements set out in Annex 8 shall apply.~~  
**The vehicle payload shall be 50-60 per cent of the maximum vehicle payload. A deviation from that range may be agreed with the approval authority. The reason for such a deviation shall be indicated in the test report. The additional requirements set out in Annex 8 shall apply."**

*Annex 10*

*Insert a new Appendix 2, to read:*

<sup>†</sup> As defined in the Consolidated Resolution on the Construction of Vehicles (R.E.3.), document ECE/TRANS/WP.29/78/Rev.3, para. 2. - [www.unece.org/trans/main/wp29/wp29wgs/wp29gen/wp29resolutions.html](http://www.unece.org/trans/main/wp29/wp29wgs/wp29gen/wp29resolutions.html)

## "Appendix 2

### Methodology for the assessment of AES

For the purposes of assessing the AES, the approval authority shall verify at least whether the requirement laid down in this Appendix are fulfilled.

1. The increase of emissions induced by the AES shall be kept at the lowest possible level:
  - (a) The increase of total emissions when using an AES shall be kept at the lowest possible level throughout the normal use and life of the vehicles;
  - (b) Whenever a technology or design that would allow for improved emission control is available on the market at the time of the AES preliminary assessment it shall be used with no unjustified modulation.
2. When used to justify an AES, the risk of sudden and irreparable damage to the engine, shall be appropriately demonstrated and documented, including the following information:
  - (a) Proof of catastrophic (i.e. sudden and irreparable) engine damage shall be provided by the manufacturer, along with a risk assessment which includes an evaluation of the likelihood of the risk occurring and severity of the possible consequences, including results of tests carried out to this effect;
  - (b) When a technology or design is available on the market at the time of the AES application that eliminates or reduces that risk, it shall be used to the largest extent technically possible (i.e. with no unjustified modulation);
  - (c) Durability and the long-term protection of the engine or components of the emission control system from wear and malfunctioning shall not be considered an acceptable reason to accept an AES.
3. An adequate technical description shall document why it is necessary to use an AES for the safe operation of the vehicle:
  - (a) Proof of an increased risk to the safe operation of the vehicle should be provided by the manufacturer along with a risk assessment which includes an evaluation of the likelihood of the risk occurring and severity of the possible consequences, including results of tests carried out to this effect;
  - (b) When a different technology or design is available on the market at the time of the AES application that would allow for lowering the safety risk, it shall be used to the largest extent technically possible (i.e. with no unjustified modulation).
4. An adequate technical description shall document why it is necessary to use an AES during engine start or warm up:
  - (a) Proof of the need to use an AES during engine start shall be provided by the manufacturer along with a risk assessment which includes an evaluation of the likelihood of the risk occurring and severity of the possible consequences, including results of tests carried out to this effect;
  - (b) Where a different technology or design is available on the market at the time of the AES application that would allow for improved

**emission control upon engine start, it shall be used to the largest extent technically possible."**

*Annex 12, Appendix 1*

*Paragraph A.1.2.1., amend to read:*

"A.1.2.1. ~~In order to receive an extension of a type approval for a vehicle in respect of its engine type approved under this Regulation to a vehicle with a reference mass exceeding 2,380 kg but not exceeding 2,610 kg the manufacturer shall meet the requirements of Regulation No.101 with the exceptions specified below.~~

**In order to receive an extension of a type approval for a vehicle in respect of its engine type approved under this Regulation to a vehicle with a reference mass exceeding 2,380 kg but not exceeding 2,610 kg, the manufacturer shall meet the requirements relating to the measurement of CO<sub>2</sub> emissions and fuel consumption established by the type 1 emissions test procedures set out in Annex B6 to UN Regulation No. [154] with only speed trace and RCB corrections. The CO<sub>2</sub> emissions shall be determined in accordance with table A6/2 of that annex not taking into account the criteria emission test results, where the vehicle during testing shall apply no AES and be considered as VH. The test reports specified in Appendix 1, Part I until paragraph 2.1. inclusive, and Appendix 2 to Annex A1 of UN Regulation No. [154], shall be submitted to the type approval authorities including the results of pollutant emissions.**

**The manufacturer shall provide the type approval authority with a signed declaration that all variants and versions for which this extension is requested are in conformity with the type-approval emission requirements in this Regulation and that the type 1 test was performed in compliance with the previous paragraph.**

**For dedicated compression ignition engines fuelled with ethanol (ED95), a fixed carbon-hydrogen-oxygen ratio shall be used for the purposes of calculating fuel consumption values, which shall be C<sub>1</sub>H<sub>2.92</sub>O<sub>0.46</sub>.**

## II. Justification

1. The emissions performance of heavy duty vehicles in the period following a cold engine start is currently not assessed as part of the type-approval demonstration test or the in-service conformity test. In order to represent real world emissions better, the measurement procedure should be revised to include measurement of pollutant emissions during the cold engine start period.
2. Particle number measurements using PEMS have been successfully implemented under the emissions type-approval rules for light passenger and commercial vehicles. It is considered appropriate to introduce a similar requirement in the emissions type-approval rules for heavy duty vehicles.
3. The rules for declaring and assessing Auxiliary Emission Strategies (AES) have been changed for light passenger and commercial vehicles and should be aligned with those for heavy duty vehicles for the sake of consistency.
4. The rules on access to vehicle OBD information shall not be limited to the emissions legislation and it is deemed appropriate to omit the provisions relating to access to such information from this Regulation. It is suggested to incorporate the rules on access to vehicle OBD information and vehicle repair and maintenance information into UN Regulation No. 0, to make these applicable at whole vehicle level.