

**Economic and Social Council**Distr.: General
9 November 2020

Original: English

Economic Commission for Europe

Inland Transport Committee

World Forum for Harmonization of Vehicle Regulations**Working Party on Noise and Tyres****Seventy-third session**

Geneva, 26-29 January 2021

Item 5 (a) of the provisional agenda

Tyres: UN Regulation No. 30 (Tyres for passenger cars and their trailers)**Proposal for a new Supplement to the 02 series of amendments to UN Regulation No. 30****Submitted by the experts from the European Tyre and Rim Technical Organisation***

The text reproduced below was prepared by the experts from the European Tyre and Rim Technical Organisation (ETRTO). It already takes into account Supplement 22 to the 02 series of amendments to UN Regulation No. 30 adopted in June 2020 but not yet in force. The modifications to the existing text of the UN Regulation are marked in bold for new or strikethrough for deleted characters.

* In accordance with the programme of work of the Inland Transport Committee for 2021 as outlined in proposed programme budget for 2021 (A/75/6 (Sect.20), para 20.51), the World Forum will develop, harmonize and update UN Regulations in order to enhance the performance of vehicles. The present document is submitted in conformity with that mandate.



I. Proposal

Paragraph 3.1.14., symbol, replace to read:

"

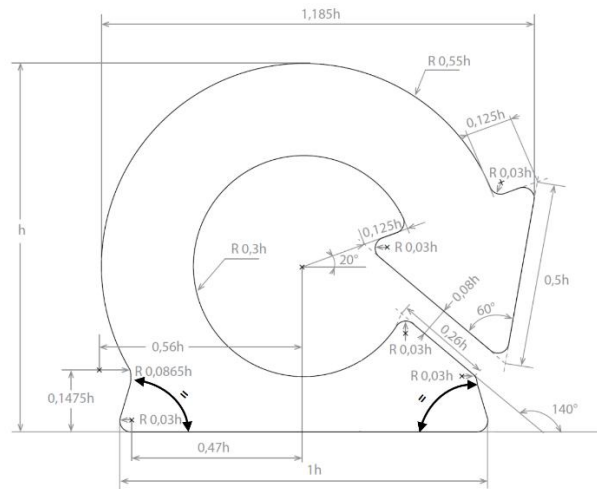

Annex 7,

Paragraph 3.2., amend to read:

"3.2. ~~Carry out the procedure as detailed in paragraphs 1.2. to 1.5. . above with a test room temperature at $38\text{ }^\circ\text{C} \pm 3\text{ }^\circ\text{C}$ in relation to conditioning the tyre and wheel assembly as detailed in paragraph 1.4. The temperature sensor shall be at a distance not less than 0.15 m and not more than 1.00 m from the tyre sidewall.~~

Inflate the tyre to an inflation pressure of 2.5 bar and condition the tyre-and-wheel assembly at a test room temperature of $38\text{ }^\circ\text{C} \pm 3\text{ }^\circ\text{C}$ for not less than three hours."

Paragraph 3.7., amend to read:

"3.7. During the test the temperature of the test room must be maintained at $38\text{ }^\circ\text{C} \pm 3\text{ }^\circ\text{C}$.

The temperature sensor shall be at a distance not less than 0.15 m and not more than 1.00 m from the tyre sidewall."

Paragraph 4.2., amend to read:

"4.2. ~~Carry out the procedure as detailed in paragraphs 1.2. to 1.5. above with a test room temperature at $25\text{ }^\circ\text{C} \pm 3\text{ }^\circ\text{C}$ in relation to conditioning the tyre and wheel assembly as detailed in paragraph 1.4. The temperature sensor shall be at a distance not less than 0.15 m and not more than 1.00 m from the tyre sidewall.~~

Inflate it to an inflation pressure of 2.5 bar and condition the tyre-and-wheel assembly at a test room temperature of $25\text{ }^\circ\text{C} \pm 3\text{ }^\circ\text{C}$ for not less than three hours."

Paragraph 4.7., amend to read:

"4.7. During the test the temperature of the test room must be maintained at $25\text{ }^\circ\text{C} \pm 3\text{ }^\circ\text{C}$.

The temperature sensor shall be at a distance not less than 0.15 m and not more than 1.00 m from the tyre sidewall."

II. Justification

1. This document presents an amendment to the extended mobility tyre (EMT) symbol following the detection of dimensional inconsistencies within the International Organization for Standardization Working Group (ISO) TC31/SC3/WG19, where the dimension "0,33h" was judged wrong and constituting an unnecessary over constraint. ISO experts agreed to correct the standard ISO 16992:2018 EMT symbol by removing such dimension and introducing the information that the two angles at the base are the same. This amendment is important to allow symbol implementation and to ensure no deviation from the requirement in reproducing it.

2. This document presents an amendment to the inflation value to be used for the tyre conditioning when assessing the "flat tyre running mode" of "run flat tyres" and of "extended mobility tyres". Indeed, as per ISO 16992:2018 this value shall not be speed dependant because the test performed for the "flat tyre running mode" is performed at constant speed irrespective of the tyre speed category. Therefore, the amendment is intended to ensure the harmonisation of this UN Regulation with the ISO standard and with other UN Regulations that may just refer to ISO 16992:2018 in setting their requirements. Also, the temperature sensor positioning requirements needs to be moved to paragraphs 3.7 and 4.7 in Annex 7 respectively for run flat and extended mobility tyres, because they address a testing parameter and not a conditioning value.
