

28 October 2011

---

## **Global registry**

**Created on 18 November 2004, pursuant to Article 6 of the Agreement concerning the establishing of global technical regulations for wheeled vehicles, equipment and parts which can be fitted and/or be used on wheeled vehicles (ECE/TRANS/132 and Corr.1) done at Geneva on 25 June 1998**

## **Addendum 11: Global technical regulation No. 11**

**Test procedure for compression-ignition engines to be installed in agricultural and forestry tractors and in non-road mobile machinery with regard to the emissions of pollutants by the engine**

## **Corrigendum 1**

Established in the Global Registry on 22 June 2011

---



UNITED NATIONS

Paragraph 3.1.8., amend to read:

"3.1.8. "Constant-speed engine" means an engine whose type approval or certification is limited to constant-speed operation. Engines whose constant-speed governor function is removed or disabled are no longer constant-speed engines;"

Paragraph 3.1.47., amend to read:

"3.1.47. "Penetration fraction  $PF$ " means the deviation from ideal functioning of a non-methane cutter (see Conversion efficiency of non-methane cutter (NMC)  $E$ ). An ideal non-methane cutter would have a methane penetration factor,  $PF_{CH_4}$ , of 1.000 (that is, a methane conversion efficiency  $E_{CH_4}$  of 0), and the penetration fraction for all other hydrocarbons would be 0.000, as represented by  $PF_{C_2H_6}$  (that is, an ethane conversion efficiency  $E_{C_2H_6}$  of 1). The relationship is:  $PF_{CH_4} = 1 - E_{CH_4}$  and  $PF_{C_2H_6} = 1 - E_{C_2H_6}$ ;"

Paragraph 3.1.55., amend to read:

"3.1.55. "Response time" means the difference in time between the change of the component to be measured at the reference point and a system response of 90 per cent of the final reading ( $t_{90}$ ) with the sampling probe being defined as the reference point, whereby the change of the measured component is at least 60 per cent full scale (FS) and the devices for gas switching shall be specified to perform the gas switching in less than 0.1 second. The system response time consists of the delay time to the system and of the rise time of the system;"

Paragraph 3.1.68., amend to read:

"3.1.68. "Tolerance" means the interval in which 95 per cent of a set of recorded values of a certain quantity shall lie, with the remaining 5 per cent of the recorded values deviating from the tolerance interval. The specified recording frequencies and time intervals shall be used to determine if a quantity is within the applicable tolerance."

Paragraph 3.2., amend to read (including the existing footnote<sup>2</sup>):

"3.2. General symbols<sup>2</sup>

<i>Symbol</i>	<i>Unit</i>	<i>Term</i>
$a_0$	-	y intercept of the regression line
$a_1$	-	Slope of the regression line
...	...	...
$r^2$	-	Coefficient of determination
...	...	...

---

<sup>2</sup> Specific symbols are found in Annexes."

*Paragraph 3.3.*, amend to read:

"3.3.	Subscripts	...	...
	denorm	...	Denormalized quantity
	...	...	...

"

*Paragraph 6.3.3.*, amend to read:

"6.3.3. Auxiliaries to be removed

Certain auxiliaries whose definition is linked with the operation of the machine and which may be mounted on the engine shall be removed for the test.

Where auxiliaries cannot be removed, the power they absorb in the unloaded condition may be determined and added to the measured engine power (see note g in the table of Annex A.5). If this value is greater than 3 per cent of the maximum power at the test speed it may be verified by the test authority. The power absorbed by auxiliaries shall be used to adjust the set values and to calculate the work produced by the engine over the test cycle."

*Paragraphs 6.6.1. and 6.6.2.*, amend to read:

"6.6.1. Continuous regeneration

For an exhaust aftertreatment system based on a continuous regeneration process the emissions shall be measured on an aftertreatment system that has been stabilized so as to result in repeatable emissions behaviour. The regeneration process shall occur at least once during the NRTC hot start test or ramped-modal cycle (RMC) test, and the manufacturer shall declare the normal conditions under which regeneration occurs (soot load, temperature, exhaust back-pressure, etc.). In order to demonstrate that the regeneration process is continuous, at least three NRTC hot start tests or ramped-modal cycle (RMC) tests shall be conducted. In case of NRTC hot start test, the engine shall be warmed up in accordance with paragraph 7.8.2.1., the engine be soaked according to paragraph 7.4.2. and the first NRTC hot start test be run. The subsequent NRTC hot start tests shall be started after soaking according to paragraph 7.4.2. During the tests, exhaust temperatures and pressures shall be recorded (temperature before and after the after-treatment system, exhaust back pressure, etc.). The aftertreatment system is considered to be satisfactory if the conditions declared by the manufacturer occur during the test during a sufficient time and the emission results do not scatter by more than  $\pm 25$  per cent or 0.005 g/kWh, whichever is greater. If the exhaust aftertreatment has a security mode that shifts to a periodic (infrequent) regeneration mode, it shall be checked according to paragraph 6.6.2. For that specific case, the applicable emission limits could be exceeded and would not be weighted.

6.6.2. Periodic (infrequent) regeneration

This provision only applies for engines equipped with emission controls that are regenerated on a periodic basis. For engines which are run on the discrete mode cycle this procedure cannot be applied.

The emissions shall be measured on at least three NRTC hot start tests or ramped-modal cycle (RMC) tests, one with and two without a regeneration event on a stabilized aftertreatment system. The regeneration process shall occur at least once during the NRTC or RMC test. If regeneration takes longer than one NRTC or RMC test, consecutive NRTC or RMC tests shall be run and emissions continued to be measured without shutting the engine off until regeneration is completed and the average of the tests shall be calculated. If regeneration is completed during any test, the test shall be continued over its entire length. The engine may be equipped with a switch capable of preventing or permitting the regeneration process provided this operation has no effect on the original engine calibration.

The manufacturer shall declare the normal parameter conditions under which the regeneration process occurs (soot load, temperature, exhaust back-pressure, etc.). The manufacturer shall also provide the frequency of the regeneration event in terms of number of tests during which the regeneration occurs. The exact procedure to determine this frequency shall be agreed by the type approval or certification authority based upon good engineering judgement.

For a regeneration test, the manufacturer shall provide an aftertreatment system that has been loaded. Regeneration shall not occur during this engine conditioning phase. As an option, the manufacturer may run consecutive NRTC hot start or RMC tests until the aftertreatment system is loaded. Emissions measurement is not required on all tests.

Average emissions between regeneration phases shall be determined from the arithmetic mean of several approximately equidistant NRTC hot start or RMC tests. As a minimum, at least one hot NRTC or RMC as close as possible prior to a regeneration test and one hot NRTC or RMC immediately after a regeneration test shall be conducted.

...

The average specific emission rate related to hot start  $\bar{e}_w$  [g/kWh] shall be weighted as follows (see figure 6.1):

$$\bar{e}_w = \frac{n \cdot \bar{e} + n_r \cdot \bar{e}_r}{n + n_r} \quad (6-3)$$

Where:

- $n$  = number of tests in which regeneration does not occur,
- $n_r$  = number of tests in which regeneration occurs (minimum one test),
- $\bar{e}$  = average specific emission without regeneration, g/kWh,
- $\bar{e}_r$  = average specific emission with regeneration, g/kWh.

At the choice of the manufacturer and based on upon good engineering analysis, the regeneration adjustment factor  $k_r$ , expressing the average emission rate, may be calculated either multiplicative or additive as follows:

**Multiplicative**

$$k_{Ur} = \frac{\bar{e}_w}{\bar{e}} \text{ (upward adjustment factor)} \quad (6-4a)$$

$$k_{Dr} = \frac{\bar{e}_w}{\bar{e}_r} \text{ (downward adjustment factor)} \quad (6-4b)$$

**Additive**

$$k_{Ur} = \bar{e}_w - \bar{e} \text{ (upward adjustment factor)} \quad (6-5)$$

$$k_{Dr} = \bar{e}_w - \bar{e}_r \text{ (downward adjustment factor)} \quad (6-6)$$

Upward adjustment factors are multiplied with or added to measured emission rates for all tests in which the regeneration does not occur. Downward adjustment factors are multiplied with or added to measured emission rates for all tests in which the regeneration occurs. The occurrence of the regeneration shall be identified in a manner that is readily apparent during all testing. Where no regeneration is identified, the upward adjustment factor shall be applied.

With reference to Annexes A.7.-8. on brake specific emission calculations, the regeneration adjustment factor:

- (a) Shall be applied to the results of the weighted NRTC and RMC tests,  
..."

*Paragraphs 7.2.1.3., figure 7.1, the title, amend to read:*

"Figure 7.1

**Test procedures for emission measurement"**

*Paragraph 7.3.1.3., amend to read:*

"7.3.1.3. Preparation of measurement equipment for sampling

...

- (j) Any electronic integrating devices shall be zeroed or re-zeroed, before the start of any test interval."

*Paragraph 7.4.2., amend to read:*

"7.4.2. Transient test cycle (NRTC)

The Non-Road Transient Cycle (NRTC) is specified in Annex A.1. as a second-by-second sequence of normalized speed and torque values. In order to perform the test in an engine test cell, the normalized values shall be converted to their equivalent reference values for the individual engine to be tested, based on specific speed and torque values identified in the engine-mapping curve. The conversion is referred to as denormalization, and the resulting test cycle is the reference NRTC test cycle of the engine to be tested (see paragraph 7.7.2.).

..."

*Paragraph 7.5.*, amend to read:

"7.5. General test sequence

...

- (h) PM filter(s) shall be pre-conditioned, weighed (empty weight), loaded, re-conditioned, again weighed (loaded weight) and then samples shall be evaluated according to pre- (para. 7.3.1.4.5.) and post-test (para. 7.3.2.2.) procedures;

...

The following diagram gives an overview about the procedures needed to conduct NRMM test cycles with measuring exhaust engine emissions.

Figure 7.3  
**Test sequence**

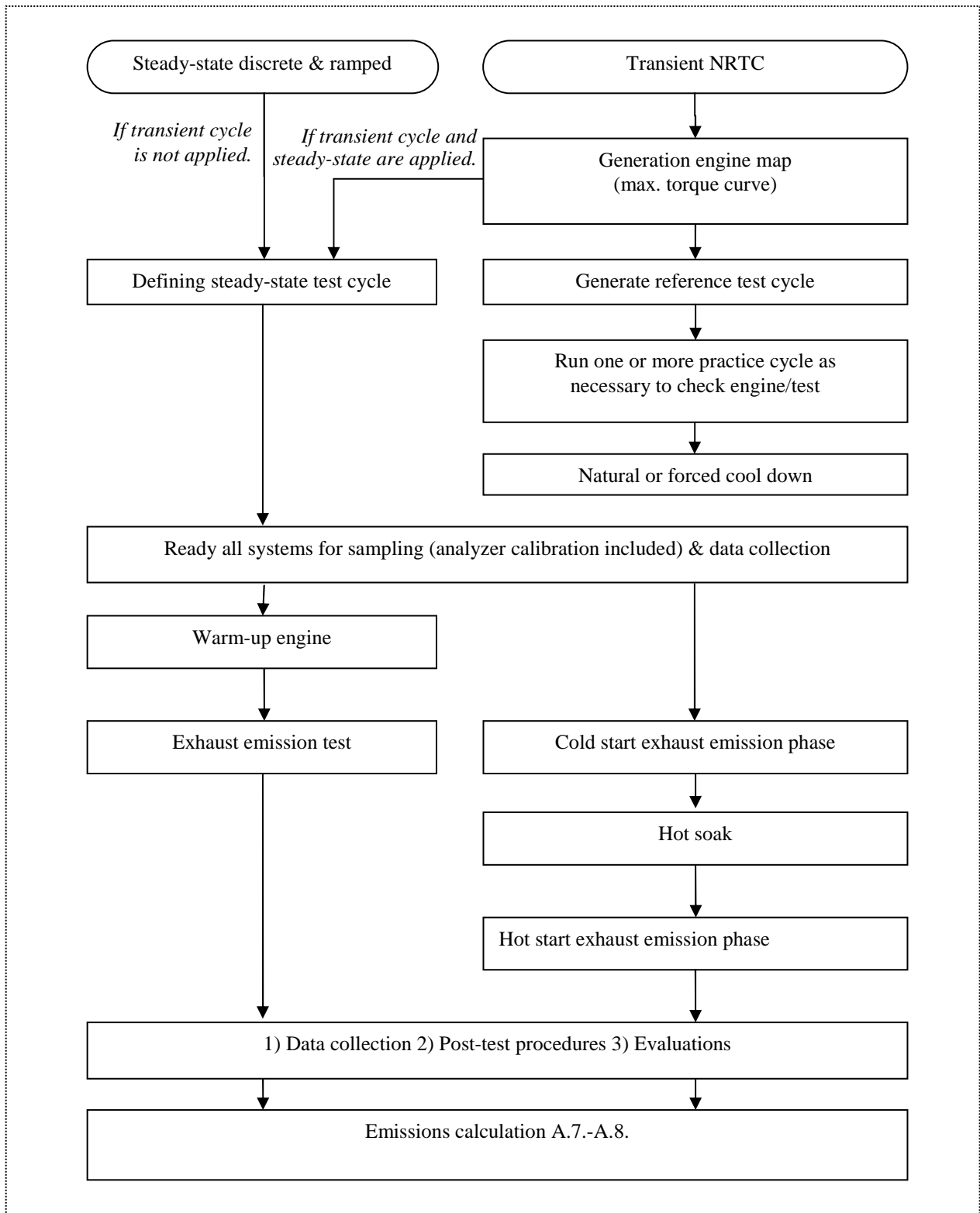

Paragraph 7.6., amend to read:

"7.6. Engine mapping

Before starting the engine mapping, the engine shall be warmed up and towards the end of the warm up it shall be operated for at least 10 minutes at maximum power or according to the recommendation of the manufacturer and good engineering judgement in order to stabilize the engine coolant and lube oil temperatures. When the engine is stabilized, the engine mapping shall be performed.

Except constant speed engines, engine mapping shall be performed with fully open fuel lever or governor using discrete speeds in ascending order. The minimum and maximum mapping speeds are defined as follows:

Minimum mapping speed = warm idle speed

Maximum mapping speed =  $n_{hi} \times 1.02$  or speed where max torque drops off to zero, whichever is smaller.

Where  $n_{hi}$  is the high speed, defined as the highest engine speed where 70 per cent of the maximum power is delivered.

If the highest speed is unsafe or unrepresentative (e.g., for ungoverned engines), good engineering judgement shall be used to map up to the maximum safe speed or the maximum representative one."

Paragraph 7.7.2.3., amend to read:

"7.7.2.3. Denormalization of engine torque

...

for the respective reference speed as determined in paragraph 7.7.2.2."

Paragraph 7.8.2.4., amend to read:

"7.8.2.4. Validation criteria

...

Table 7.1

**RMC Regression line tolerances**

	<i>Speed</i>	<i>Torque</i>	<i>Power</i>
Standard error of estimate ( <i>SEE</i> ) of <i>y</i> on <i>x</i>	maximum 1 per cent of rated speed	maximum 2 per cent of maximum engine torque	maximum 2 per cent of maximum engine power
Slope of the regression line, $a_1$	0.99 to 1.01	0.98 - 1.02	0.98 - 1.02
Coefficient of determination, $r^2$	minimum 0.990	minimum 0.950	minimum 0.950
<i>y</i> intercept of the regression line, $a_0$	$\pm 1$ per cent of rated speed	$\pm 20$ Nm or 2 per cent of maximum torque whichever is greater	$\pm 4$ kW or 2 per cent of maximum power whichever is greater

..."



Paragraph 7.8.3., amend to read:

"7.8.3. Transient test cycle (NRTC)

...

Small denormalized speed values near warm idle speed may cause low-speed idle governors to activate and the engine torque to exceed the reference torque even though the operator demand is at a minimum. In such cases, it is recommended to control the dynamometer so it gives priority to follow the reference torque instead of the reference speed and let the engine govern the speed.

..."

Paragraph 7.8.3.5., amend to read:

"7.8.3.5. Validation statistics (see Annex A.2.)

Linear regression between the reference and the feedback values shall be calculated for speed, torque and power.

To minimize the biasing effect of the time lag between the reference and feedback cycle values, the entire engine speed and torque feedback signal sequence may be advanced or delayed in time with respect to the reference speed and torque sequence. If the feedback signals are shifted, both speed and torque shall be shifted by the same amount in the same direction.

The method of least squares shall be used, with the best-fit equation having the form:

$$y = a_1x + a_0 \quad (7-6)$$

Where:

$y$  = feedback value of speed ( $\text{min}^{-1}$ ), torque (Nm), or power (kW)

$a_1$  = slope of the regression line

$x$  = reference value of speed ( $\text{min}^{-1}$ ), torque (Nm), or power (kW)

$a_0$  = y intercept of the regression line

The standard error of estimate (*SEE*) of  $y$  on  $x$  and the coefficient of determination ( $r^2$ ) shall be calculated for each regression line (Annex A.2.).

It is recommended that this analysis be performed at 1 Hz. For a test to be considered valid, the criteria of table 7.2 of this paragraph shall be met.

Table 7.2  
**Regression line tolerances**

	<i>Speed</i>	<i>Torque</i>	<i>Power</i>
Standard error of estimate ( <i>SEE</i> ) of <i>y</i> on <i>x</i>	≤ 5.0 percent of maximum test speed	≤ 10.0 per cent of maximum mapped torque	≤ 10.0 per cent of maximum mapped power
Slope of the regression line, $a_1$	0.95 to 1.03	0.83 - 1.03	0.89 - 1.03
Coefficient of determination, $r^2$	minimum 0.970	minimum 0.850	minimum 0.910
<i>y</i> intercept of the regression line, $a_0$	≤ ±10 per cent of idle	±20 Nm or ±2 per cent of maximum torque whichever is greater	±4 kW or ±2 per cent of maximum power whichever is greater

For regression ... specified.

Table 7.3  
**Permitted point deletions from regression analysis**

<i>Event</i>	<i>Conditions (n = engine speed, T = torque)</i>	<i>Permitted point deletions</i>
Minimum operator demand (idle point)	$n_{ref} = n_{idle}$ and $T_{ref} = 0$ per cent and $T_{act} > (T_{ref} - 0.02 T_{maxmappedtorque})$ and $T_{act} < (T_{ref} + 0.02 T_{maxmappedtorque})$	speed and power
Minimum operator demand	$n_{act} \leq 1.02 n_{ref}$ and $T_{act} > T_{ref}$ or $n_{act} > n_{ref}$ and $T_{act} \leq T_{ref}$ or $n_{act} > 1.02 n_{ref}$ and $T_{ref} < T_{act} \leq (T_{ref} + 0.02 T_{maxmappedtorque})$	power and either torque or speed
Maximum operator demand	$n_{act} < n_{ref}$ and $T_{act} \geq T_{ref}$ or $n_{act} \geq 0.98 n_{ref}$ and $T_{act} < T_{ref}$ or $n_{act} < 0.98 n_{ref}$ and $T_{ref} > T_{act} \geq (T_{ref} - 0.02 T_{maxmappedtorque})$	power and either torque or speed

"

Paragraph 8.1.4.3., amend to read:

"8.1.4.3. Procedure

The following linearity verification protocol shall be used:

...

- (i) At a recording frequency of at least the minimum frequency, as specified in table 9.2, the reference value shall be measured for 30 s and the arithmetic mean of the recorded values,  $\bar{y}_i$  recorded;
- (j) Steps in paragraphs (g) through (i) of this paragraph shall be repeated until all reference quantities are measured;
- (k) The arithmetic means  $\bar{y}_i$ , and reference values,  $y_{refi}$ , shall be used to calculate least-squares linear regression parameters and statistical values to compare to the minimum performance criteria specified in table 8.2. The calculations described in Annex A.2. shall be used."

Paragraph 8.1.8.4., figure 8.1, amend to read:

"Figure 8.1

**Schematic diagrams for diluted exhaust flow CVS calibration**

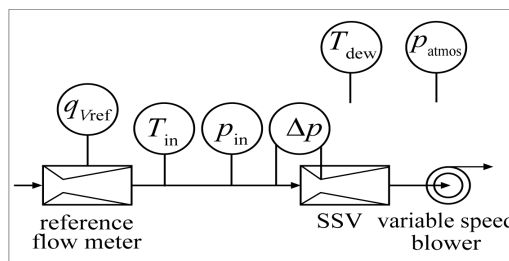
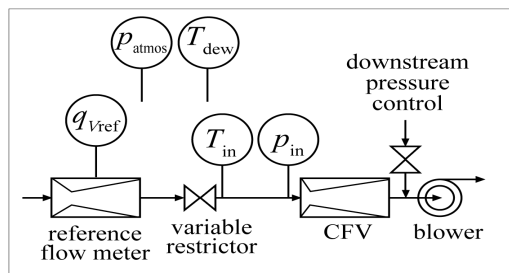
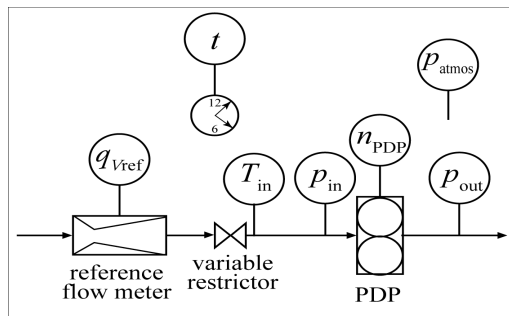

"

Paragraphs 8.1.8.4.2. and 8.1.8.4.3., amend to read:

"8.1.8.4.2. PDP calibration

A positive-displacement pump (PDP) shall be calibrated to determine a flow-versus-PDP speed equation that accounts for flow leakage across sealing surfaces in the PDP as a function of PDP inlet pressure. Unique equation coefficients shall be determined for each speed at which the PDP is operated. A PDP flow meter shall be calibrated as follows:

...

- (f) The PDP is operated for at least 3 minutes to stabilize the system. Then by continuously operating the PDP, the mean values of at least 30 s of sampled data of each of the following quantities are recorded:
- (i) The mean flow rate of the reference flow meter,  $\bar{q}_{Vref}$  ;
  - (ii) The mean temperature at the PDP inlet,  $T_{in}$ ;
  - (iii) The mean static absolute pressure at the PDP inlet,  $p_{in}$ ;
  - (iv) The mean static absolute pressure at the PDP outlet,  $p_{out}$ ;
  - (v) The mean PDP speed,  $n_{PDP}$ ;

...

8.1.8.4.3. CFV calibration

A critical-flow venturi (CFV) shall be calibrated to verify its discharge coefficient,  $C_d$ , at the lowest expected static differential pressure between the CFV inlet and outlet. A CFV flow meter shall be calibrated as follows:

...

- (f) The CFV shall be operated for at least 3 minutes to stabilize the system. The CFV shall continue operating and the mean values of at least 30 s of sampled data of each of the following quantities shall be recorded:
- (i) The mean flow rate of the reference flow meter,  $\bar{q}_{Vref}$  ;
  - (ii) Optionally, the mean dew point of the calibration air,  $T_{dew}$ . See Annexes A.7-A.8 for permissible assumptions during emission measurements;
  - (iii) The mean temperature at the venturi inlet,  $T_{in}$ ;
  - (iv) The mean static absolute pressure at the venturi inlet,  $p_{in}$ ;
  - (v) The mean static differential pressure between the CFV inlet and the CFV outlet,  $\Delta p_{CFV}$ ;

..."

*Paragraph 8.1.8.5.1., amend to read:*

"8.1.8.5.1. Introduction

- (a) A propane check serves as a CVS verification to determine if there is a discrepancy in measured values of diluted exhaust flow. A propane check also serves as a batch-sampler verification to determine if there is a discrepancy in a batch sampling system that extracts a sample from a CVS, as described in paragraph (f) of this paragraph. Using good engineering judgment and safe practices, this check may be performed using a gas other than propane, such as CO<sub>2</sub> or CO. A failed propane check might indicate one or more problems that may require corrective action, as follows:

...

- (iv) The hydrocarbon contamination verification in the sample system shall be performed as described in paragraph 7.3.1.2.;

..."

*Paragraph 8.1.8.5.4., amend to read:*

"8.1.8.5.4. Preparation of the HC sampling system for the propane check

Vacuum side leak check verification of the HC sampling system may be performed according to (g) of this paragraph. If this procedure is used, the HC contamination procedure in paragraph 7.3.1.2. may be used. If the vacuum side leak check is not performed according to (g), then the HC sampling system shall be zeroed, spanned, and verified for contamination, as follows:

..."

*Paragraph 8.1.8.5.7., amend to read:*

"8.1.8.5.7. PM secondary dilution system verification

When the propane check is to be repeated to verify the PM secondary dilution system, the following procedure from (a) to (d) shall be used for this verification:

...

- (d) The reference C<sub>3</sub>H<sub>8</sub> mass shall be subtracted from the calculated mass. If this difference is within ±5 per cent of the reference mass, the batch sampler passes this verification. If not, corrective action shall be taken."

*Paragraph 8.1.8.5.8., amend to read:*

"8.1.8.5.8. Sample dryer verification

If a humidity sensor for continuous monitoring of dew point at the sample dryer outlet is used this check does not apply, as long as it is ensured that the dryer outlet humidity is below the minimum values used for quench, interference, and compensation checks.

- (a) If a sample dryer is used as allowed in paragraph 9.3.2.3.1. to remove water from the sample gas, the performance shall be verified upon installation, after major maintenance, for thermal chiller. For osmotic

membrane dryers, the performance shall be verified upon installation, after major maintenance, and within 35 days of testing;

...

- (d) The following sample dryer verification procedure method shall be used to determine sample dryer performance, or good engineering judgment shall be used to develop a different protocol:

...

- (vii) The sample dryer meets the verification if the result of paragraph (d)(vi) of this paragraph is less than the dew point corresponding to the sample dryer specifications as determined in paragraph 9.3.2.3.1. plus 2 °C or if the mol fraction from (d)(vi) is less than the corresponding sample dryer specifications plus 0.002 mol/mol or 0.2 volume per cent. Note for this verification, sample dew point is expressed in absolute temperature, Kelvin."

*Paragraph 8.1.8.6.1.*, amend to read:

"8.1.8.6.1. Specifications for differential flow measurement

...

Acceptable accuracies of  $q_{mp}$  can be obtained by either of the following methods:

...

- (c) The accuracy of  $q_{mp}$  is determined indirectly from the accuracy of the dilution ratio as determined by a tracer gas, e.g. CO<sub>2</sub>. Accuracies equivalent to method (a) for  $q_{mp}$  are required;

..."

*Paragraph 8.1.8.6.3.*, amend to read:

"8.1.8.6.3. Special requirements for differential flow measurement

A carbon flow check using actual exhaust is strongly recommended for detecting measurement and control problems and verifying the proper operation of the partial flow system. The carbon flow check should be run at least each time a new engine is installed, or something significant is changed in the test cell configuration.

..."

*Paragraph 8.1.8.7.1.*, amend to read:

"8.1.8.7.1. Scope and frequency

Upon initial sampling system installation, after major maintenance such as pre-filter changes, and within 8 hours prior to each duty-cycle sequence, it shall be verified that there are no significant vacuum-side leaks using one of the leak tests described in this section. This verification does not apply to any full-flow portion of a CVS dilution system."

*Paragraph 8.1.9.1.4., amend to read:*

"8.1.9.1.4. Procedure

The interference verification shall be performed as follows:

...

- (d) The humidified test gas shall be introduced into the sampling system. The humidified test gas may be introduced downstream of any sample dryer, if one is used during testing;

..."

*Paragraph 8.1.9.2.4., amend to read:*

"8.1.9.2.4. Procedure

The interference verification shall be performed as follows:

...

- (c) The humidified CO<sub>2</sub> test gas shall be introduced into the sampling system. The humidified CO<sub>2</sub> test gas may be introduced downstream of any sample dryer, if one is used during testing;

..."

*Paragraph 8.1.10.1.3., amend to read:*

"8.1.10.1.3. HC FID response optimization

This procedure is only for FID analyzers that measure HC.

- (a) Instrument manufacturer requirements and good engineering judgment shall be used for initial instrument start-up and basic operating adjustment using FID fuel and zero air. Heated FIDs shall be within their required operating temperature ranges. FID response shall be optimized to meet the requirement of the hydrocarbon response factors and the oxygen interference check according to paragraphs 8.1.10.1.1. (a) and 8.1.10.2. at the most common analyzer range expected during emission testing. Higher analyzer range may be used according to the instrument manufacturer's recommendation and good engineering judgment in order to optimize FID accurately, if the common analyzer range is lower than the minimum range for the optimization specified by the instrument manufacturer;

...

- (c) The following step from (1) to (4) or the procedure instructed by the instrument manufacturer shall be taken for optimization. The procedures outlined in SAE paper No. 770141 may be optionally used for optimization;

...

- (iii) The difference between the span and zero response shall be plotted and the fuel flow adjusted to the rich side of the curve. This is the initial flow rate setting which may need further optimization depending on the results of the hydrocarbon response factors and the oxygen interference check according to paragraphs 8.1.10.1.1.(a) and 8.1.10.2;

- (iv) If the oxygen interference or the hydrocarbon response factors do not meet the following specifications, the airflow shall be incrementally adjusted above and below the manufacturer's specifications, repeating paragraphs 8.1.10.1.1.(a) and 8.1.10.2. for each flow;

..."

*Paragraph 8.1.11.2., amend to read:*

"8.1.11.2. CLD quench verification calculations

CLD quench-check calculations shall be performed as described in this paragraph."

*Paragraph 8.1.11.2.3., amend to read:*

"8.1.11.2.3. Combined H<sub>2</sub>O and CO<sub>2</sub> quench calculations

...

$x_{H_2O_{meas}}$  = measured mole fraction of water during the quench verification according to paragraph 8.1.11.1.5.(g)

$x_{NO_{meas}}$  = measured concentration of NO when NO span gas is blended with CO<sub>2</sub> span gas, according to paragraph 8.1.11.1.4.(j)

$x_{NO_{act}}$  = actual concentration of NO when NO span gas is blended with CO<sub>2</sub> span gas, according to paragraph 8.1.11.1.4.(k) and calculated according to equation (8-5)

$x_{CO_2_{exp}}$  = maximum expected concentration of CO<sub>2</sub> during emission testing, according to paragraph 8.1.11.2.2.

..."

*Paragraph 8.1.11.3.4., amend to read:*

"8.1.11.3.4. Procedure

The interference verification shall be performed as follows:

...

- (g) This difference shall be multiplied by the ratio of the expected mean HC concentration to the HC concentration measured during the verification. The analyzer meets the interference verification of this paragraph if this result is within ±2 per cent of the NO<sub>x</sub> concentration expected at the standard:

$$\left| \bar{x}_{NO_x,CLD,meas} - \bar{x}_{NO_x,NDUV,meas} \right| \cdot \left( \frac{\bar{x}_{HC,exp}}{\bar{x}_{HC,meas}} \right) \leq 2\% \cdot (\bar{x}_{NO_x,exp}) \quad (8-6)$$

Where:

$\bar{x}_{NO_x,CLD,meas}$  = the mean concentration of NO<sub>x</sub> measured by CLD [μmol/mol] or [ppm]

$\bar{x}_{NO_x,NDUV,meas}$  = the mean concentration of NO<sub>x</sub> measured by NDUV [μmol/mol] or [ppm]



$\bar{x}_{\text{HC,meas}}$	=	the mean concentration of HC measured [ $\mu\text{mol/mol}$ ] or [ppm]
$\bar{x}_{\text{HC,exp}}$	=	the mean concentration of HC expected at the standard [ $\mu\text{mol/mol}$ ] or [ppm]
$\bar{x}_{\text{NOx,exp}}$	=	the mean concentration of $\text{NO}_x$ expected at the standard [ $\mu\text{mol/mol}$ ] or [ppm]"

Paragraph 8.1.12.2.5., amend to read:

"8.1.12.2.5. Correction calculation

The PM sample filter shall be corrected for buoyancy using the following equations:

$$m_{\text{cor}} = m_{\text{uncor}} \cdot \left( \frac{1 - \frac{\rho_{\text{air}}}{\rho_{\text{weight}}}}{1 - \frac{\rho_{\text{air}}}{\rho_{\text{media}}}} \right) \quad (8-8)$$

Where:

$m_{\text{cor}}$  = PM sample filter mass corrected for buoyancy

$m_{\text{uncor}}$  = PM sample filter mass uncorrected for buoyancy

..."

Paragraph 8.2.4.5., amend to read:

"8.2.4.5. Stabilisation of PM samples

To stabilise PM samples, they shall be placed in one or more containers that are open to the PM-stabilization environment, which is described in paragraph 9.3.4.3. A PM sample is stabilized as long as it has been in the PM-stabilization environment for one of the following durations, during which the stabilization environment has been within the specifications of paragraph 9.3.4.3.:

..."

Paragraph 9.3.2.3.1.2., amend to read:

"9.3.2.3.1.2. Type of sample dryers allowed and procedure to estimate moisture content after the dryer

Either type of sample dryer described in this paragraph to decrease the effects of water on gaseous emission measurements may be used.

- (a) If an osmotic-membrane dryer upstream of any gaseous analyzer or storage medium is used, it shall meet the temperature specifications in paragraph 9.3.2.2. The dew point,  $T_{\text{dew}}$ , and absolute pressure,  $p_{\text{total}}$ , downstream of an osmotic-membrane dryer shall be monitored. The amount of water shall be calculated as specified in Annexes A.7-A.8 by using continuously recorded values of  $T_{\text{dew}}$  and  $p_{\text{total}}$  or their peak values observed during a test or their alarm set points. Lacking a direct measurement, the nominal  $p_{\text{total}}$  is given by the dryer's lowest absolute pressure expected during testing.

- (b) A thermal chiller upstream of a THC measurement system for compression-ignition engines may not be used. If a thermal chiller upstream of an NO<sub>2</sub>-to-NO converter or in a sampling system without an NO<sub>2</sub>-to-NO converter is used, the chiller shall meet the NO<sub>2</sub> loss-performance check specified in paragraph 8.1.11.4. The dew point,  $T_{\text{dew}}$ , and absolute pressure,  $p_{\text{total}}$ , downstream of a thermal chiller shall be monitored. The amount of water shall be calculated as specified in Annexes A.7.-A.8 by using continuously recorded values of  $T_{\text{dew}}$  and  $p_{\text{total}}$  or their peak values observed during a test or their alarm set points. Lacking a direct measurement, the nominal  $p_{\text{total}}$  is given by the thermal chiller's lowest absolute pressure expected during testing. If it is valid to assume the degree of saturation in the thermal chiller,  $T_{\text{dew}}$  based on the known chiller efficiency and continuous monitoring of chiller temperature,  $T_{\text{chiller}}$  may be calculated. If values of  $T_{\text{chiller}}$  are not continuously recorded, its peak value observed during a test, or its alarm setpoint, may be used as a constant value to determine a constant amount of water according to Annexes A.7-A.8. If it is valid to assume that  $T_{\text{chiller}}$  is equal to  $T_{\text{dew}}$ ,  $T_{\text{chiller}}$  may be used in lieu of  $T_{\text{dew}}$  according to Annexes A.7-A.8. If it is valid to assume a constant temperature offset between  $T_{\text{chiller}}$  and  $T_{\text{dew}}$ , due to a known and fixed amount of sample reheat between the chiller outlet and the temperature measurement location, this assumed temperature offset value may be factored in into emission calculations. The validity of any assumptions allowed by this paragraph shall be shown by engineering analysis or by data."

Paragraph 9.3.2.4., table 9.1, amend to read:

"Table 9.1

**Gaseous Batch Sampling Container Materials**

CO, CO <sub>2</sub> , O <sub>2</sub> , CH <sub>4</sub> , C <sub>2</sub> H <sub>6</sub> , C <sub>3</sub> H <sub>8</sub> , NO, NO <sub>2</sub> <sup>1</sup>	polyvinyl fluoride (PVF) <sup>2</sup> for example Tedlar <sup>TM</sup> , polyvinylidene fluoride <sup>2</sup> for example Kynar <sup>TM</sup> , polytetrafluoroethylene <sup>3</sup> for example Teflon <sup>TM</sup> , or stainless steel <sup>3</sup>
THC, NMHC	polytetrafluoroethylene <sup>4</sup> or stainless steel <sup>4</sup>

<sup>1</sup> As long as aqueous condensation in storage container is prevented.

<sup>2</sup> Up to 40 °C.

<sup>3</sup> Up to 202 °C.

<sup>4</sup> At (191 ±11) °C."

Paragraph 9.4.4.1.2., amend to read:

"9.4.4.1.2. Shaft work

Work and power shall be calculated from outputs of speed and torque transducers according to paragraph 9.4.4.1. Overall systems for measuring speed and torque shall meet the calibration and verifications in paragraphs 8.1.7. and 8.1.4.

Torque induced by the inertia of accelerating and decelerating components connected to the flywheel, such as the drive shaft and dynamometer rotor, shall be compensated for as needed, based on good engineering judgment."

Paragraph 9.4.5.3.2., amend to read:

"9.4.5.3.2. Flow meter response time

For the purpose of controlling of a partial flow dilution system to extract a proportional raw exhaust sample, a flow meter response time faster than indicated in table 9.3 is required. For partial flow dilution systems with online control, the flow meter response time shall meet the specifications of paragraph 8.2.1.2."

Paragraph 9.4.7.3., amend to read:

"9.4.7.3. Gas chromatograph

Application: A gas chromatograph may be used to measure CH<sub>4</sub> concentrations of diluted exhaust for batch sampling. While also a non-methane cutter may be used to measure CH<sub>4</sub>, as described in paragraph 9.4.7.2. a reference procedure based on a gas chromatograph shall be used for comparison with any proposed alternate measurement procedure under paragraph 5.1.3."

Paragraph 9.5.1.1.(a), table 9.4, amend to read:

"Table 9.4

**Contamination limits, applicable for raw or dilute measurements [ $\mu\text{mol/mol}$  = ppm (3.2.)]**

Constituent	Purified Synthetic Air <sup>a</sup>	Purified N <sub>2</sub> <sup>a</sup>
THC (C <sub>1</sub> equivalent)	$\leq 0.05 \mu\text{mol/mol}$	$\leq 0.05 \mu\text{mol/mol}$
CO	$\leq 1 \mu\text{mol/mol}$	$\leq 1 \mu\text{mol/mol}$
CO <sub>2</sub>	$\leq 10 \mu\text{mol/mol}$	$\leq 10 \mu\text{mol/mol}$
O <sub>2</sub>	0.205 to 0.215 mol/mol	$\leq 2 \mu\text{mol/mol}$
NO <sub>x</sub>	$\leq 0.02 \mu\text{mol/mol}$	$\leq 0.02 \mu\text{mol/mol}$

<sup>a</sup> It is not required that these levels of purity are internationally and/or nationally recognized standards traceable."

Paragraph A.2.1., equation (A.2-1), amend to read:

$$" \bar{y} = \frac{\sum_{i=1}^N y_i}{N} \quad (\text{A.2-1})"$$

Paragraph A.2.8., equation (A.2-10), amend to read:

$$" SEE_y = \sqrt{\frac{\sum_{i=1}^N [y_i - a_{0y} - (a_{1y} \cdot y_{refi})]^2}{N - 2}} \quad (\text{A.2-10})"$$

Paragraph A.4.1., amend to read:

"A.4.1. Introduction

...

Figure A.4.1 shows the sampling points at which the carbon flows shall be checked. The specific equations for the carbon flows at each of the sample points are given in the following paragraphs.

Figure A.4.1

**Measuring points for carbon flow check**

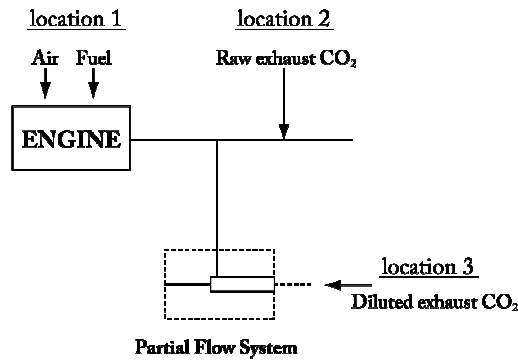

"

Paragraphs A.4.3. to A.4.5., amend to read:

"A.4.3. Carbon flow rate in the raw exhaust (location 2)

...

If CO<sub>2</sub> is measured on a dry basis it shall be converted to a wet basis according to paragraph A.7.3.2. or A.8.2.2.

A.4.4. Carbon flow rate in the dilution system (location 3)

...

If CO<sub>2</sub> is measured on a dry basis it shall be converted to a wet basis according to paragraph A.7.3.2. or A.8.2.2.

A.4.5. Calculation of the molar mass of the exhaust gas

The molar mass of the exhaust gas shall be calculated according to equation (A.8-15) (see paragraph A.8.2.4.2.).

..."

Annex A.5., amend to read (including the existing footnotes <sup>h,i</sup>):

## "Annex A.5

### Installation requirements for equipment and auxiliaries

<i>Number</i>	<i>Equipment and auxiliaries</i>	<i>Fitted for emission test</i>
...	...	...

<sup>h</sup> Charge ... by the manufacturer.

<sup>i</sup> The power ... test bed."

Paragraphs A.7.0.1., amend to read (including the existing footnotes <sup>1,7</sup>):

"A.7.0.1. General symbols

<i>Annex 7<sup>1</sup></i>	<i>Annex 8</i>	<i>Unit</i>	<i>Quantity</i>
...	...	...	...
$a_0$	$b, D_0$	t.b.d. <sup>7</sup>	y intercept of the regression line, PDP calibration intercept
$a_1$	$m$	t.b.d. <sup>7</sup>	Slope of the regression line
...	...	...	...
$\mu$	$\mu$	kg/(m·s)	Dynamic viscosity
...	...	...	...

<sup>1</sup> See subscripts; e.g.:  $\dot{m}_{\text{air}}$  for mass rate of dry air or  $\dot{m}_{\text{fuel}}$  for fuel mass rate.

<sup>7</sup> t.b.d.= to be defined."

Paragraph A.7.1.1., amend to read:

"A.7.1.1. Dry air and chemical species

...

This annex uses the following molar masses or effective molar masses of chemical species:

...

$M_{\text{NMHC}} = 13.875389$  g/mol (non-methane hydrocarbon<sup>(a)</sup>)

$M_{\text{NOx}} = 46.0055$  g/mol (oxides of nitrogen<sup>(b)</sup>)

...

$M_{\text{THC}} = 13.875389$  g/mol (total hydrocarbon<sup>(a)</sup>)

- (a) The effective molar masses of THC and NMHC are defined by an atomic hydrogen-to-carbon ratio,  $\alpha$ , of 1.85;
- (b) The effective molar mass of  $\text{NO}_x$  is defined by the molar mass of nitrogen dioxide,  $\text{NO}_2$ .

..."

Paragraph A.7.1.4.1., amend to read:

"A.7.1.4.1. THC determination and THC/ $\text{CH}_4$  initial contamination corrections

- (a) If THC emissions are required to be determined,  $x_{\text{THC}[\text{THC-FID}]}$  shall be calculated by using the initial THC contamination concentration  $x_{\text{THC}[\text{THC-FID}]\text{init}}$  from paragraph 7.3.1.2. as follows:

...

..."

Paragraph A.7.1.4.2., amend to read:

"A.7.1.4.2. NMHC determination

To determine NMHC concentration,  $x_{\text{NMHC}}$ , one of the following shall be used:

...

- (b) For non-methane cutters,  $x_{\text{NMHC}}$  shall be calculated using the non-methane cutter's penetration fractions ( $PF$ ) of  $\text{CH}_4$  and  $\text{C}_2\text{H}_6$  from paragraph 8.1.10.3., and using the HC contamination and dry-to-wet corrected THC concentration  $x_{\text{THC}[\text{THC-FID}]\text{cor}}$  as determined in subparagraph (a) of A.7.1.4.1.;
- (i) The following equation for penetration fractions determined using an NMC configuration as outlined in paragraph 8.1.10.3.4.1. shall be used:

$$x_{\text{NMHC}} = \frac{x_{\text{THC}[\text{THC-FID}]\text{cor}} - x_{\text{THC}[\text{NMC-FID}]} \cdot RF_{\text{CH}_4[\text{THC-FID}]}}{1 - RF_{\text{C}_2\text{H}_6[\text{NMC-FID}]} \cdot RF_{\text{CH}_4[\text{THC-FID}]}} \quad (\text{A.7-6})$$

Where:

...

$x_{\text{THC}[\text{NMC-FID}]}$  = concentration of THC, HC contamination (optional) and dry-to-wet corrected, as measured by the NMC FID during sampling through the NMC

$RF_{\text{CH}_4[\text{THC-FID}]}$  = response factor of THC FID to  $\text{CH}_4$ , according to paragraph 8.1.10.1.4.

$RF_{\text{C}_2\text{H}_6[\text{NMC-FID}]}$  = non-methane cutter combined ethane response factor and penetration fraction, according to paragraph 8.1.10.3.4.1.

- (ii) For penetration fractions determined using an NMC configuration as outlined in paragraph 8.1.10.3.4.2., the following equation shall be used:

$$x_{\text{NMHC}} = \frac{x_{\text{THC}[\text{THC-FID}]_{\text{cor}}} \cdot PF_{\text{CH}_4[\text{NMC-FID}]} - x_{\text{THC}[\text{NMC-FID}]}}{PF_{\text{CH}_4[\text{NMC-FID}]} - PF_{\text{C}_2\text{H}_6[\text{NMC-FID}]}} \quad (\text{A.7-7})$$

Where:

...

$PF_{\text{CH}_4[\text{NMC-FID}]}$  = non-methane cutter  $\text{CH}_4$  penetration fraction, according to paragraph 8.1.10.3.4.2.

$x_{\text{THC}[\text{NMC-FID}]}$  = concentration of THC, HC contamination (optional) and dry-to-wet corrected, as measured by the NMC FID during sampling through the NMC

$PF_{\text{C}_2\text{H}_6[\text{NMC-FID}]}$  = non-methane cutter ethane penetration fraction, according to paragraph 8.1.10.3.4.2.

- (iii) For penetration fractions determined using an NMC configuration as outlined in paragraph 8.1.10.3.4.3., the following equation shall be used:

...

Where:

...

$PF_{\text{CH}_4[\text{NMC-FID}]}$  = non-methane cutter  $\text{CH}_4$  penetration fraction, according to paragraph 8.1.10.3.4.3.

$x_{\text{THC}[\text{NMC-FID}]}$  = concentration of THC, HC contamination (optional) and dry-to-wet corrected, as measured by the NMC FID during sampling through the NMC

$RFPF_{\text{C}_2\text{H}_6[\text{NMC-FID}]}$  = non-methane cutter  $\text{CH}_4$  combined ethane response factor and penetration fraction, according to paragraph 8.1.10.3.4.3.

$RF_{\text{CH}_4[\text{THC-FID}]}$  = response factor of THC FID to  $\text{CH}_4$ , according to paragraph 8.1.10.1.4.

- (c) For a gas chromatograph,  $x_{\text{NMHC}}$  shall be calculated using the THC analyzer's response factor ( $RF$ ) for  $\text{CH}_4$ , from paragraph 8.1.10.1.4., and the HC contamination and dry-to-wet corrected initial THC concentration  $x_{\text{THC}[\text{THC-FID}]_{\text{cor}}}$  as determined in paragraph (a) above as follows:

..."

Paragraph A.7.2.3., amend to read:

"A.7.2.3. Chemical balance procedure

...

Use the following steps to complete a chemical balance:

- (a) Measured concentrations such as,  $x_{\text{CO}_2\text{meas}}$ ,  $x_{\text{NOmeas}}$ , and  $x_{\text{H}_2\text{Oint}}$ , shall be converted to dry concentrations by dividing them by one minus the amount of water present during their respective measurements; for example:  $x_{\text{H}_2\text{OxCO}_2\text{meas}}$ ,  $x_{\text{H}_2\text{OxNOmeas}}$ , and  $x_{\text{H}_2\text{Oint}}$ . If the amount of water present during a "wet" measurement is the same as the unknown amount of water in the exhaust flow,  $x_{\text{H}_2\text{Oexh}}$ , it has to be iteratively solved for that value in the system of equations. If only total  $\text{NO}_x$  are measured and not NO and  $\text{NO}_2$  separately, good engineering judgement shall be used to estimate a split in the total  $\text{NO}_x$  concentration between NO and  $\text{NO}_2$  for the chemical balances. The molar concentration of  $\text{NO}_x$ ,  $x_{\text{NOx}}$ , may be assumed to be 75 per cent NO and 25 per cent  $\text{NO}_2$ . For  $\text{NO}_2$  storage aftertreatment systems,  $x_{\text{NOx}}$  may be assumed to be 25 per cent NO and 75 per cent  $\text{NO}_2$ . For calculating the mass of  $\text{NO}_x$  emissions, the molar mass of  $\text{NO}_2$  for the effective molar mass of all  $\text{NO}_x$  species, regardless of the actual  $\text{NO}_2$  fraction of  $\text{NO}_x$ , shall be used;
- (b) Equations (A.7-10 to A.7-26) in paragraph (d) of this paragraph A.7.2.3. have to be entered into a computer program to iteratively solve for  $x_{\text{H}_2\text{Oexh}}$ ,  $x_{\text{Ccombdry}}$  and  $x_{\text{dil/exh}}$ . Good engineering judgment shall be used to guess initial values for  $x_{\text{H}_2\text{Oexh}}$ ,  $x_{\text{Ccombdry}}$ , and  $x_{\text{dil/exh}}$ . Guessing an initial amount of water that is about twice the amount of water in the intake or dilution air is recommended. Guessing an initial value of  $x_{\text{Ccombdry}}$  as the sum of the measured  $\text{CO}_2$ , CO, and THC values is recommended. Guessing an initial  $x_{\text{dil}}$  between 0.75 and 0.95 ( $0.75 < x_{\text{dil}} < 0.95$ ), such as 0.8 is also recommended. Values in the system of equations shall be iterated until the most recently updated guesses are all within  $\pm 1$  per cent of their respective most recently calculated values;

...

At the end of the chemical balance, the molar flow rate  $\dot{n}_{\text{exh}}$  is calculated as specified in paragraphs A.7.3.3. and A.7.4.3."



Paragraph A.7.3.3., amend to read:

"A.7.3.3. Exhaust gas molar flow rate

The flow rate of the raw exhaust gases can be directly measured or can be calculated based on the chemical balance of paragraph A.7.2.3. Calculation of raw exhaust molar flow rate is performed from measured intake air molar flow rate or fuel mass flow rate. The raw exhaust molar flow rate can be calculated from the sampled emissions,  $\dot{n}_{\text{exh}}$ , based on the measured intake air molar flow rate,  $\dot{n}_{\text{int}}$ , or the measured fuel mass flow rate,  $\dot{m}_{\text{fuel}}$ , and the values calculated using the chemical balance in paragraph A.7.2.3. It shall be solved for the chemical balance in paragraph A.7.2.3. at the same frequency that  $\dot{n}_{\text{int}}$  or  $\dot{m}_{\text{fuel}}$  is updated and recorded.

..."

Paragraph A.7.4.1., amend to read:

"A.7.4.1. Emission mass calculation and background correction

Equations for the calculation of gaseous emissions mass  $m_{\text{gas}}$  [g/test] as a function of molar emissions flow rates are as follows:

(a) Continuous sampling, varying flow rate

$$m_{\text{gas}} = \frac{1}{f} \cdot M_{\text{gas}} \cdot \sum_{i=1}^N \dot{n}_{\text{exhi}} \cdot x_{\text{gasi}} \quad (\text{see A.7-29})$$

Where:

$M_{\text{gas}}$  = generic emission molar mass [g/mol]

$\dot{n}_{\text{exhi}}$  = instantaneous exhaust gas molar flow rate on a wet basis [mol/s]

$x_{\text{gasi}}$  = instantaneous generic gas molar concentration on a wet basis [mol/mol]

$f$  = data sampling rate [Hz]

$N$  = number of measurements [-]

Continuous sampling, constant flow rate

$$m_{\text{gas}} = M_{\text{gas}} \cdot \dot{n}_{\text{exh}} \cdot \bar{x}_{\text{gas}} \cdot \Delta t \quad (\text{see A.7-31})$$

Where:

$M_{\text{gas}}$  = generic emission molar mass [g/mol]

$\dot{n}_{\text{exh}}$  = exhaust gas molar flow rate on a wet basis [mol/s]

$\bar{x}_{\text{gas}}$  = mean gaseous emission molar fraction on a wet basis [mol/mol]

$\Delta t$  = time duration of test interval

- (b) Batch sampling, regardless varying flow or constant rate is, the following equation shall be used:

$$m_{\text{gas}} = \frac{1}{f} \cdot M_{\text{gas}} \cdot \bar{x}_{\text{gas}} \cdot \sum_{i=1}^N \dot{n}_{\text{exhi}} \quad (\text{see A.7-32})$$

Where:

$M_{\text{gas}}$  = generic emission molar mass [g/mol]

$\dot{n}_{\text{exhi}}$  = instantaneous exhaust gas molar flow rate on a wet basis [mol/s]

$\bar{x}_{\text{gas}}$  = mean gaseous emission molar fraction on a wet basis [mol/mol]

$f$  = data sampling rate [Hz]

$N$  = number of measurements [-]

..."

Paragraph A.7.4.4.1., amend to read:

"A.7.4.4.1. Sampling

...

- (b) Sampling from a constant flow rate

...

For sampling with a constant dilution ratio ( $DR$ ),  $m_{\text{PM}}$  [g] shall be calculated using the following equation:

$$m_{\text{PM}} = m_{\text{PMdil}} \cdot DR \quad (\text{A.7-46})$$

Where:

$m_{\text{PMdil}}$  = PM mass in dilution air [g]

$DR$  = dilution ratio [-] defined as the ratio between the mass of the emission  $m$  and the mass of diluted exhaust  $m_{\text{dil/exh}}$  ( $DR = m/m_{\text{dil/exh}}$ ).

The dilution ratio  $DR$  can be expressed as a function of  $x_{\text{dil/exh}}$ :

$$DR = \frac{1}{1 - x_{\text{dil/exh}}} \quad (\text{A.7-47})$$

Annex A.7, Appendix 1, amend to read:

## "Annex A.7

### Appendix 1

#### Diluted exhaust flow (CVS) calibration

##### A.7.6. Introduction

This Appendix 1 describes the calculations for calibrating various flow meters. Paragraph A.7.6.1. of this Appendix 1 first describes how to convert reference flow meter outputs for use in the calibration equations, which are presented on a molar basis. The remaining paragraphs describe the calibration calculations that are specific to certain types of flow meters.

##### A.7.6.1. ...

##### A.7.6.2. PDP calibration calculations

...

- (d) The procedure in subparagraphs (a) through (c) of this paragraph shall be repeated for every speed that PDP is operated;

...

##### A.7.6.3. Venturi governing equations and permissible assumptions

This section describes the governing equations and permissible assumptions for calibrating a venturi and calculating flow using a venturi. Because a subsonic venturi (SSV) and a critical-flow venturi (CFV) both operate similarly, their governing equations are nearly the same, except for the equation describing their pressure ratio,  $r$  (*i.e.*,  $r_{SSV}$  versus  $r_{CFV}$ ). These governing equations assume one-dimensional isentropic inviscid compressible flow of an ideal gas. In paragraph A.7.6.3.(d), ... Molar flow rate,  $\dot{n}$  [mol/s], shall be calculated as follows:

$$\dot{n} = C_d \cdot C_f \cdot \frac{A_t \cdot p_{in}}{\sqrt{Z \cdot M_{mix} \cdot R \cdot T_{in}}} \quad (\text{A.7-60})$$

Where:

$C_d$  = Discharge coefficient, as determined in paragraph A.7.6.3.(a) [-]

$C_f$  = Flow coefficient, as determined in paragraph A.7.6.3.(b) [-]

...

##### A.7.6.4. SSV calibration

- (a) Molar based approach. To calibrate an SSV flow meter the following steps shall be performed:

- (i) The Reynolds number,  $Re^\#$ , for ... approximate  $\mu$ :

...

and, using the Sutherland three-coefficient viscosity model:

$$\mu = \mu_0 \left( \frac{T_{in}}{T_0} \right)^{\frac{3}{2}} \cdot \left( \frac{T_0 + S}{T_{in} + S} \right) \quad (A.7-67)$$

Where:

- $\mu$  = Dynamic viscosity of calibration gas [kg/(m·s)]
- $\mu_0$  = Sutherland reference viscosity [kg/(m·s)]
- $S$  = Sutherland constant [K]
- $T_0$  = Sutherland reference temperature [K]
- $T_{in}$  = Absolute temperature at the venturi inlet [K]

...

..."

Paragraphs A.7.7.1. to A.7.7.3., amend to read:

"A.7.7.1. Scope and frequency

The calculations in this Appendix 2 are performed to determine if gas analyzer drift invalidates the results of a test interval. If drift does not invalidate the results of a test interval, the test interval's gas analyzer responses shall be corrected for drift according to this Appendix 2. The drift-corrected gas analyzer responses shall be used in all subsequent emission calculations. The acceptable threshold for gas analyzer drift over a test interval is specified in paragraph 8.2.2.2.

A.7.7.2. Correction principles

The calculations in this Appendix 2 utilize a gas analyzer's responses to reference zero and span concentrations of analytical gases, as determined sometime before and after a test interval. The calculations correct the gas analyzer's responses that were recorded during a test interval. The correction is based on an analyzer's mean responses to reference zero and span gases, and it is based on the reference concentrations of the zero and span gases themselves. Validation and correction for drift shall be performed as follows:

A.7.7.3. Drift validation

After applying all the other corrections—except drift correction—to all the gas analyzer signals, brake-specific emissions shall be calculated according to A.7.5. Then all gas analyzer signals shall be corrected for drift according to this Appendix 2. Brake-specific emissions shall be recalculated using all of the drift-corrected gas analyzer signals. The brake-specific emission results shall be validated and reported before and after drift correction according to paragraph 8.2.2.2."

Paragraph A.8.0.1., amend to read (including the existing footnote <sup>3</sup>):

"A.8.0.1. General symbols

<i>Annex 8</i>	<i>Annex 7</i>	<i>Unit</i>	<i>Quantity</i>
$b, D_0$	$a_0$	t.b.d. <sup>3</sup>	y intercept of the regression line
$m$	$a_1$	t.b.d. <sup>3</sup>	Slope of the regression line
...	...	...	...
$\mu$	$\mu$	kg/(m·s)	Dynamic viscosity
...	...	...	...

...

<sup>3</sup> t.b.d.= to be defined."

Paragraph A.8.2.1.2., amend to read:

"A.8.2.1.2. Transient and ramped modal cycles tests

The total mass per test of a gaseous emission  $m_{\text{gas}}$  [g/test] shall be calculated by multiplication of the time aligned instantaneous concentrations and exhaust gas flows and integration over the test cycle according to the following equation:

..."

Paragraph A.8.2.3., amend to read:

"A.8.2.3. NO<sub>x</sub> correction for humidity and temperature

As the NO<sub>x</sub> emission depends on ambient air conditions, the NO<sub>x</sub> concentration shall be corrected for ambient air temperature and humidity with the factors  $k_h$  [-] given in the following equation. This factor is valid for a humidity range between 0 and 25 g H<sub>2</sub>O/kg dry air.

..."

Paragraph A.8.2.4.1., table A.8.1, amend to read:

"Table A.8.1

**Raw exhaust gas  $u$  and component densities (the  $u$  figures are calculated for emission concentration expressed in ppm)**

Gas	NO <sub>x</sub>	CO	HC	CO <sub>2</sub>	O <sub>2</sub>	CH <sub>4</sub>	
$\rho_{\text{gas}}$ [kg/m <sup>3</sup> ]	2.053	1.250	0.621	1.9636	1.4277	0.716	
Fuel	$\rho_e$ [kg/m <sup>3</sup> ]	Coefficient $u_{\text{gas}}$ at $\lambda = 2$ , dry air, 273 K, 101.3 kPa					
Diesel	1.2939	0.001587	0.000966	0.000479	0.001518	0.001103	0.000553

"

Paragraph A.8.3.2., amend to read:

"A.8.3.2. Dry-to wet concentration conversion

All concentrations in paragraph A.8.3.2. shall be converted using equation (A.8-5) ( $c_w = k_w \cdot c_d$ )."

Paragraph A.8.3.3., table A.8.2, amend to read:

"Table A.8.2

**Diluted exhaust gas  $u$  values and component densities (the  $u$  figures are calculated for emission concentration expressed in ppm)**

Gas	NO <sub>x</sub>	CO	HC	CO <sub>2</sub>	O <sub>2</sub>	CH <sub>4</sub>	
$\rho_{\text{gas}}$ [kg/m <sup>3</sup> ]	2.053	1.250	0.621	1.9636	1.4277	0.716	
Fuel	$\rho_c$ [kg/m <sup>3</sup> ]	Coefficient $u_{\text{gas}}$ at $\lambda = 2$ , dry air, 273 K, 101.3 kPa					
Diesel	1.293	0.001588	0.000967	0.000480	0.001519	0.001104	0.000553

Paragraphs A.8.3.4.1. to A.8.3.4.3., amend to read:

"A.8.3.4.1. PDP-CVS system

The calculation of the mass of the diluted exhaust [kg/test] over the cycle is as follows, if the temperature of the diluted exhaust  $m_{\text{ed}}$  is kept within  $\pm 6$  K over the cycle by using a heat exchanger:

$$m_{\text{ed}} = 1.293 \cdot V_0 \cdot n_p \cdot \frac{p_p}{101.325} \cdot \frac{273.15}{\bar{T}} \quad (\text{A.8-36})$$

Where:

$V_0$  = volume of gas pumped per revolution under test conditions [m<sup>3</sup>/rev]

$n_p$  = total revolutions of pump per test [rev/test]

$p_p$  = absolute pressure at pump inlet [kPa]

$\bar{T}$  = average temperature of the diluted exhaust gas at pump inlet [K]

1.293 kg/m<sup>3</sup> = air density at 273.15 K and 101.325 kPa

If a system with flow compensation is used (i.e. without heat exchanger), the mass of the diluted exhaust gas  $m_{\text{ed},i}$  [kg] during the time interval shall be calculated as follows:

$$m_{\text{ed},i} = 1.293 \cdot V_0 \cdot n_{p,i} \cdot \frac{p_p}{101.325} \cdot \frac{273.15}{\bar{T}} \quad (\text{A.8-37})$$

Where:

$V_0$  = volume of gas pumped per revolution under test conditions [m<sup>3</sup>/rev]

$p_p$  = absolute pressure at pump inlet [kPa]

$n_{p,i}$	=	total revolutions of pump per time interval $i$ [rev/ $\Delta t$ ]
$\bar{T}$	=	average temperature of the diluted exhaust gas at pump inlet [K]
1.293 kg/m <sup>3</sup>	=	air density at 273.15 K and 101.325 kPa

## A.8.3.4.2. CFV-CVS system

The calculation of the mass flow over the cycle  $m_{ed}$  [g/test] is as follows, if the temperature of the diluted exhaust is kept within  $\pm 11$  K over the cycle by using a heat exchanger:

$$m_{ed} = \frac{1.293 \cdot t \cdot K_v \cdot p_p}{T^{0.5}} \quad (\text{A.8-38})$$

Where:

$t$	=	cycle time [s]
$K_v$	=	calibration coefficient of the critical flow venturi for standard conditions $\left[ \left( \sqrt{\text{K}} \cdot \text{m}^4 \cdot \text{s} \right) / \text{kg} \right]$
$p_p$	=	absolute pressure at venturi inlet [kPa]
$T$	=	absolute temperature at venturi inlet [K]
1.293 kg/m <sup>3</sup>	=	air density at 273.15 K and 101.325 kPa

If a system with flow compensation is used (i.e. without heat exchanger), the mass of the diluted exhaust gas  $m_{ed,i}$  [kg] during the time interval shall be calculated as follows:

$$m_{ed,i} = \frac{1.293 \cdot \Delta t_i \cdot K_v \cdot p_p}{T^{0.5}} \quad (\text{A.8-39})$$

Where:

$\Delta t_i$	=	time interval of the test [s]
$K_v$	=	calibration coefficient of the critical flow venturi for standard conditions $\left[ \left( \sqrt{\text{K}} \cdot \text{m}^4 \cdot \text{s} \right) / \text{kg} \right]$
$p_p$	=	absolute pressure at venturi inlet [kPa]
$T$	=	absolute temperature at venturi inlet [K]
1.293 kg/m <sup>3</sup>	=	air density at 273.15 K and 101.325 kPa

## A.8.3.4.3. SSV-CVS system

The calculation of the diluted exhaust gas mass over the cycle  $m_{ed}$  [kg/test] shall be as follows, if the temperature of the diluted exhaust is kept within  $\pm 11$  K over the cycle by using a heat exchanger:

$$m_{ed} = 1.293 \cdot q_{vSSV} \cdot \Delta t \quad (\text{A.8-40})$$

Where:

1.293 kg/m <sup>3</sup>	=	air density at 273.15 K and 101.325 kPa
-------------------------	---	---

$\Delta t$  = cycle time [s]  
 $q_{vSSV}$  = air flow rate at standard conditions (101.325 kPa, 273.15 K) [m<sup>3</sup>/s]

with

$$q_{vSSV} = \frac{A_0}{60} d_v^2 C_d P_p \sqrt{\left[ \frac{1}{T_{in}} (r_p^{1.4286} - r_p^{1.7143}) \cdot \left( \frac{1}{1 - r_D^4 r_p^{1.4286}} \right) \right]} \quad (\text{A.8-41})$$

...

If a system with flow compensation is used (i.e. without heat exchanger), the mass of the diluted exhaust gas  $m_{ed,i}$  [kg] during the time interval shall be calculated as follows:

$$m_{ed,i} = 1.293 \cdot q_{vSSV} \cdot \Delta t_i \quad (\text{A.8-42})$$

Where:

1.293 kg/m<sup>3</sup> = air density at 273.15 K and 101.325 kPa  
 $\Delta t_i$  = time interval [s]  
 $q_{vSSV}$  = volumetric flow rate of the SSV [m<sup>3</sup>/s]"

Paragraph A.8.3.5.2.2., amend to read:

"A.8.3.5.2.2. Calculation of the particulate mass flow rate

The particulate emission flow rate over the cycle  $q_{mPM}$  [g/h] shall be calculated as follows:

...

(b) For the multiple-filter method

$$q_{mPMi} = \frac{m_{fi}}{m_{sepi}} \cdot q_{medfi} \cdot \frac{3600}{1000} \quad (\text{A.8-57})$$

Where:

$q_{mPMi}$  = particulate mass flow rate for the mode  $i$  [g/h]  
 $m_{fi}$  = particulate sample mass collected at mode  $i$  [mg]  
 $q_{medfi}$  = equivalent diluted exhaust gas mass flow rate on wet basis at mode  $i$  [kg/s]  
 $m_{sepi}$  = mass of diluted exhaust sample passed through the particulate sampling filter at mode  $i$  [kg]

The PM mass is determined over the test cycle by summation of the average values of the individual modes  $i$  during the sampling period.

The particulate mass flow rate  $q_{mPM}$  [g/h] or  $q_{mPMi}$  [g/h] may be background corrected as follows:



(c) For the single-filter method

$$q_{mPM} = \left\{ \frac{m_f}{m_{sep}} - \left[ \frac{m_{f,d}}{m_d} \cdot \sum_{i=1}^N \left( 1 - \frac{1}{D_i} \right) \cdot WF_i \right] \right\} \cdot \overline{q_{medf}} \cdot \frac{3600}{1000} \quad (\text{A.8-58})$$

Where:

- $q_{mPM}$  = particulate mass flow rate [g/h]  
 $m_f$  = particulate sample mass collected [mg]  
 $m_{sep}$  = mass of diluted exhaust sample passed through the particulate sampling filter [kg]  
 $m_{f,d}$  = particulate sample mass of the dilution air collected [mg]  
 $m_d$  = mass of the dilution air sample passed through the particulate sampling filters [kg]  
 $D_i$  = dilution factor at mode  $i$  (see equation (A.8-29) of paragraph A.8.3.2.2.) [-]  
 $WF_i$  = weighting factor for the mode  $i$  [-]  
 $\overline{q_{medf}}$  = average equivalent diluted exhaust gas mass flow rate on wet basis [kg/s]

(d) For the multiple-filter method

$$q_{mPMi} = \left\{ \frac{m_{fi}}{m_{sepi}} - \left[ \frac{m_{f,d}}{m_d} \cdot \left( 1 - \frac{1}{D} \right) \right] \right\} \cdot q_{medfi} \cdot \frac{3600}{1000} \quad (\text{A.8-59})$$

Where:

- $q_{mPMi}$  = particulate mass flow rate at mode  $i$  [g/h]  
 $m_{fi}$  = particulate sample mass collected at mode  $i$  [mg]  
 $m_{sepi}$  = mass of diluted exhaust sample passed through the particulate sampling filter at mode  $i$  [kg]  
 $m_{f,d}$  = particulate sample mass of the dilution air collected [mg]  
 $m_d$  = mass of the dilution air sample passed through the particulate sampling filters [kg]  
 $D$  = dilution factor (see equation (A.8-29) of paragraph A.8.3.2.2.) [-]  
 $q_{medfi}$  = equivalent diluted exhaust gas mass flow rate on wet basis at mode  $i$  [kg/s]

If more than one measurement is made,  $m_{f,d}/m_d$  shall be replaced with  $\overline{m_{f,d}/m_d}$ ."

Paragraph A.8.4.2.1., amend to read:

"A.8.4.2.1. Transient and ramped modal cycles

The particulate specific emissions shall be calculated with equation (A.8-61) where  $e_{\text{gas}}$  [g/kWh] and  $m_{\text{gas}}$  [g/test] are substituted by  $e_{\text{PM}}$  [g/kWh] and  $m_{\text{PM}}$  [g/test] respectively:

$$e_{\text{PM}} = \frac{m_{\text{PM}}}{W_{\text{act}}} \quad (\text{A.8-64})$$

Where:

$m_{\text{PM}}$  = total mass of particulates emission, calculated according to paragraph A.8.3.5. [g/test]

..."

Paragraphs A.8.5.1. to A.8.5.3., amend to read:

"A.8.5.1. Positive displacement pump (PDP)

...

The airflow rate ( $q_{\text{vcvs}}$ ) at each restriction setting (minimum 6 settings) shall be calculated in standard  $\text{m}^3/\text{s}$  from the flowmeter data using the manufacturer's prescribed method. The airflow rate shall then be converted to pump flow ( $V_0$ ) in  $\text{m}^3/\text{rev}$  at absolute pump inlet temperature and pressure as follows:

$$V_0 = \frac{q_{\text{vcvs}}}{n} \cdot \frac{T}{273.15} \cdot \frac{101.325}{p_p} \quad (\text{A.8-68})$$

Where:

$q_{\text{vcvs}}$  = air flow rate at standard conditions (101.325 kPa, 273.15 K) [ $\text{m}^3/\text{s}$ ]

...

A.8.5.2. Critical flow venturi (CFV)

...

The airflow rate ( $q_{\text{vcvs}}$ ) at each restriction setting (minimum 8 settings) shall be calculated in standard  $\text{m}^3/\text{s}$  from the flowmeter data using the manufacturer's prescribed method. The calibration coefficient  $K_v$  [ $(\sqrt{\text{K}} \cdot \text{m}^4 \cdot \text{s})/\text{kg}$ ] shall be calculated from the calibration data for each setting as follows:

$$K_v = \frac{q_{\text{vcvs}} \cdot \sqrt{T}}{P_p} \quad (\text{A.8-71})$$

Where:

$q_{\text{vcvs}}$  = air flow rate at standard conditions (101.325 kPa, 273.15 K) [ $\text{m}^3/\text{s}$ ]

...

A.8.5.3. Subsonic venturi (SSV)

...

The airflow rate ( $q_{vSSV}$ ) at each restriction setting (minimum 16 settings) shall be calculated in standard  $m^3/s$  from the flowmeter data using the manufacturer's prescribed method. The discharge coefficient shall be calculated from the calibration data for each setting as follows:

$$C_d = \frac{q_{vSSV}}{\frac{A_0}{60} d_v^2 p_p \sqrt{\left[ \frac{1}{T_{in,V}} (r_p^{1.4286} - r_p^{1.7143}) \left( \frac{1}{1 - r_D^4 r_p^{1.4286}} \right) \right]}} \quad (A.8-72)$$

Where:

$$A_0 = \text{collection of constants and units conversions} = 0.0056940 \left[ \frac{m^3 \cdot K^{\frac{1}{2}} \cdot 1}{min \cdot kPa \cdot mm^2} \right]$$

$$q_{vcvs} = \text{air flow rate at standard conditions (101.325 kPa, 273.15 K)} [m^3/s]$$

...

To determine the range of subsonic flow,  $C_d$  shall be plotted as a function of Reynolds number  $Re$ , at the SSV throat. The  $Re$  at the SSV throat shall be calculated with the following equation:

$$Re = A_1 \cdot 60 \cdot \frac{q_{vSSV}}{d_v \cdot \mu} \quad (A.8-73)$$

with

$$\mu = \frac{b \times T^{1.5}}{S + T} \quad (A.8-74)$$

Where:

$$A_1 = \text{collection of constants and units conversions} = 27.43831 \left[ \frac{Kg \cdot min \cdot mm}{m^3 \cdot s \cdot m} \right]$$

$$q_{vcvs} = \text{air flow rate at standard conditions (101.325 kPa, 273.15 K)} [m^3/s]$$

$$d_v = \text{diameter of the SSV throat [mm]}$$

$$\mu = \text{absolute or dynamic viscosity of the gas [kg/(m·s)]}$$

$$b = 1.458 \times 10^6 \text{ (empirical constant) [kg/(m·s·K}^{0.5}\text{)]}$$

$$S = 110.4 \text{ (empirical constant) [K]}$$

..."

## Appendix 2

Paragraph 3.1.8., amend to read:

"3.1.8. "Constant-speed engine" means an engine whose type approval or certification is limited to constant-speed operation. Engines whose constant-speed governor function is removed or disabled are no longer constant-speed engines;"

Paragraph 3.1.32., amend to read:

"3.1.32. "Intermediate test speed" means that engine speed which meets one of the following requirements:

- (a) for engines which are designed to operate over a speed range on a full load torque curve, the intermediate speed shall be the declared maximum torque speed if it occurs between 60 per cent and 75 per cent of rated speed;
- (b) if the declared maximum torque speed is less than 60 per cent of rated speed, then the intermediate speed shall be 60 per cent of the rated speed;
- (c) if the declared maximum torque speed is greater than 75 per cent of the rated speed then the intermediate speed shall be 75 per cent of rated speed.

Rated speed is replaced by the denormalization speed in the generation of steady-state 8-mode test cycle (discrete and ramp modal) for engines that are tested with both the steady state and also the transient cycle."

Paragraph 3.1.47., amend to read:

"3.1.47. "Penetration fraction  $PF$ " means the deviation from ideal functioning of a non-methane cutter (see Conversion efficiency of non-methane cutter (NMC)  $E$ ). An ideal non-methane cutter would have a methane penetration factor,  $PF_{CH_4}$ , of 1.000 (that is, a methane conversion efficiency  $E_{CH_4}$  of 0), and the penetration fraction for all other hydrocarbons would be 0.000, as represented by  $PF_{C_2H_6}$  (that is, an ethane conversion efficiency  $E_{C_2H_6}$  of 1). The relationship is:  $PF_{CH_4} = 1 - E_{CH_4}$  and  $PF_{C_2H_6} = 1 - E_{C_2H_6}$ ;"

Paragraph 3.1.53., amend to read:

"3.1.53. "Rated speed" means the maximum full load speed allowed by the governor, as designed by the manufacturer, or, if such a governor is not present, the speed at which the maximum power is obtained from the engine, as designed by the manufacturer;

Rated speed is replaced by the denormalization speed in the generation of steady-state 8-mode test cycle (discrete and ramp modal) for engines that are tested with both the steady state and also the transient cycle."

Paragraph 3.1.55., amend to read:

"3.1.55. "Response time" means the difference in time between the change of the component to be measured at the reference point and a system response of 90 per cent of the final reading ( $t_{90}$ ) with the sampling probe being defined as the reference point, whereby the change of the measured component is at least 60 per cent full scale (FS) and the devices for gas switching shall be specified to perform the gas switching in less than 0.1 second. The system response time consists of the delay time to the system and of the rise time of the system;"

Paragraph 3.1.68., amend to read:

"3.1.68. "Tolerance" means the interval in which 95 per cent of a set of recorded values of a certain quantity shall lie, with the remaining 5 per cent of the recorded values deviating from the tolerance interval. The specified recording frequencies and time intervals shall be used to determine if a quantity is within the applicable tolerance;"

Paragraph 3.2., amend to read (including the existing footnote <sup>2</sup>):

"3.2. General symbols<sup>2</sup>

<i>Symbol</i>	<i>Unit</i>	<i>Term</i>
$a_0$	-	y intercept of the regression line
$a_1$	-	Slope of the regression line
...	...	...
$r^2$	-	Coefficient of determination
...	...	...

---

<sup>2</sup> Specific symbols are found in Annexes."

Paragraph 3.3., amend to read:

"3.3. Subscripts

...	...
denorm	Denormalized quantity
...	...

"

Paragraph 6.3.3., amend to read:

"6.3.3. Auxiliaries to be removed

Certain auxiliaries whose definition is linked with the operation of the machine and which may be mounted on the engine shall be removed for the test.

Where auxiliaries cannot be removed, the power they absorb in the unloaded condition may be determined and added to the measured engine power (see note g in the table of Annex A.5). If this value is greater than 3 per cent of the maximum power at the test speed it may be verified by the test authority. The power absorbed by auxiliaries shall be used to adjust the set values and to calculate the work produced by the engine over the test cycle."

Paragraphs 6.6.1. and 6.6.2., amend to read:

"6.6.1. Continuous regeneration

For an exhaust aftertreatment system based on a continuous regeneration process the emissions shall be measured on an aftertreatment system that has been stabilized so as to result in repeatable emissions behaviour. The regeneration process shall occur at least once during the NRTC hot start test or ramped-modal cycle (RMC) test, and the manufacturer shall declare the normal conditions under which regeneration occurs (soot load, temperature, exhaust back-pressure, etc.). In order to demonstrate that the regeneration process is continuous, at least three NRTC hot start tests or ramped-modal

cycle (RMC) tests shall be conducted. In case of NRTC hot start test, the engine shall be warmed up in accordance with paragraph 7.8.2.1., the engine be soaked according to paragraph 7.4.2. and the first NRTC hot start test be run. The subsequent NRTC hot start tests shall be started after soaking according to paragraph 7.4.2. During the tests, exhaust temperatures and pressures shall be recorded (temperature before and after the after-treatment system, exhaust back pressure, etc.). The aftertreatment system is considered to be satisfactory if the conditions declared by the manufacturer occur during the test during a sufficient time and the emission results do not scatter by more than  $\pm 25$  per cent or 0.005 g/kWh, whichever is greater. If the exhaust aftertreatment has a security mode that shifts to a periodic (infrequent) regeneration mode, it shall be checked according to paragraph 6.6.2. For that specific case, the applicable emission limits could be exceeded and would not be weighted.

6.6.2. Periodic (infrequent) regeneration

This provision only applies for engines equipped with emission controls that are regenerated on a periodic basis. For engines which are run on the discrete mode cycle this procedure cannot be applied.

The emissions shall be measured on at least three NRTC hot start tests or ramped-modal cycle (RMC) tests, one with and two without a regeneration event on a stabilized aftertreatment system. The regeneration process shall occur at least once during the NRTC or RMC test. If regeneration takes longer than one NRTC or RMC test, consecutive NRTC or RMC tests shall be run and emissions continued to be measured without shutting the engine off until regeneration is completed and the average of the tests shall be calculated. If regeneration is completed during any test, the test shall be continued over its entire length. The engine may be equipped with a switch capable of preventing or permitting the regeneration process provided this operation has no effect on the original engine calibration.

The manufacturer shall declare the normal parameter conditions under which the regeneration process occurs (soot load, temperature, exhaust back-pressure, etc.). The manufacturer shall also provide the frequency of the regeneration event in terms of number of tests during which the regeneration occurs. The exact procedure to determine this frequency shall be agreed by the type approval or certification authority based upon good engineering judgement.

For a regeneration test, the manufacturer shall provide an aftertreatment system that has been loaded. Regeneration shall not occur during this engine conditioning phase. As an option, the manufacturer may run consecutive NRTC hot start or RMC tests until the aftertreatment system is loaded. Emissions measurement is not required on all tests.

Average emissions between regeneration phases shall be determined from the arithmetic mean of several approximately equidistant NRTC hot start or RMC tests. As a minimum, at least one hot NRTC or RMC as close as possible prior to a regeneration test and one hot NRTC or RMC immediately after a regeneration test shall be conducted.

...

The average specific emission rate related to hot start  $\bar{e}_w$  [g/kWh] shall be weighted as follows (see figure 6.1):

$$\bar{e}_w = \frac{n \cdot \bar{e} + n_r \cdot \bar{e}_r}{n + n_r} \quad (6-3)$$

Where:

- $n$  = number of tests in which regeneration does not occur,  
 $n_r$  = number of tests in which regeneration occurs (minimum one test),  
 $\bar{e}$  = average specific emission without regeneration, g/kWh,  
 $\bar{e}_r$  = average specific emission with regeneration, g/kWh.

At the choice of the manufacturer and based on upon good engineering analysis, the regeneration adjustment factor  $k_r$ , expressing the average emission rate, may be calculated either multiplicative or additive as follows:

#### Multiplicative

$$k_{Ur} = \frac{\bar{e}_w}{\bar{e}} \text{ (upward adjustment factor)} \quad (6-4a)$$

$$k_{Dr} = \frac{\bar{e}_w}{\bar{e}_r} \text{ (downward adjustment factor)} \quad (6-4b)$$

#### Additive

$$k_{Ur} = \bar{e}_w - \bar{e} \text{ (upward adjustment factor)} \quad (6-5)$$

$$k_{Dr} = \bar{e}_w - \bar{e}_r \text{ (downward adjustment factor)} \quad (6-6)$$

Upward adjustment factors are multiplied with or added to measured emission rates for all tests in which the regeneration does not occur. Downward adjustment factors are multiplied with or added to measured emission rates for all tests in which the regeneration occurs. The occurrence of the regeneration shall be identified in a manner that is readily apparent during all testing. Where no regeneration is identified, the upward adjustment factor shall be applied.

With reference to Annexes A.7.-8. on brake specific emission calculations, the regeneration adjustment factor:

- (a) Shall be applied to the results of the weighted NRTC and RMC tests,  
 ..."

*Paragraphs 7.2.1.3., figure 7.1, the title, amend to read:*

"Figure 7.1  
**Test procedures for emission measurement"**

*Paragraph 7.3.1.3.*, amend to read:

"7.3.1.3. Preparation of measurement equipment for sampling

...

- (j) Any electronic integrating devices shall be zeroed or re-zeroed, before the start of any test interval."

*Paragraph 7.4.2.*, amend to read:

"7.4.2. Transient test cycle (NRTC)

The Non-Road Transient Cycle (NRTC) is specified in Annex A.1. as a second-by-second sequence of normalized speed and torque values. In order to perform the test in an engine test cell, the normalized values shall be converted to their equivalent reference values for the individual engine to be tested, based on specific speed and torque values identified in the engine-mapping curve. The conversion is referred to as denormalization, and the resulting test cycle is the reference NRTC test cycle of the engine to be tested (see paragraph 7.7.2).

..."

*Paragraph 7.5.*, amend to read:

"7.5. General test sequence

...

- (h) PM filter(s) shall be pre-conditioned, weighed (empty weight), loaded, re-conditioned, again weighed (loaded weight) and then samples shall be evaluated according to pre- (para. 7.3.1.5.) and post-test (para. 7.3.2.2.) procedures;

...

The following diagram gives an overview about the procedures needed to conduct NRMM test cycles with measuring exhaust engine emissions.



Figure 7.3  
Test sequence

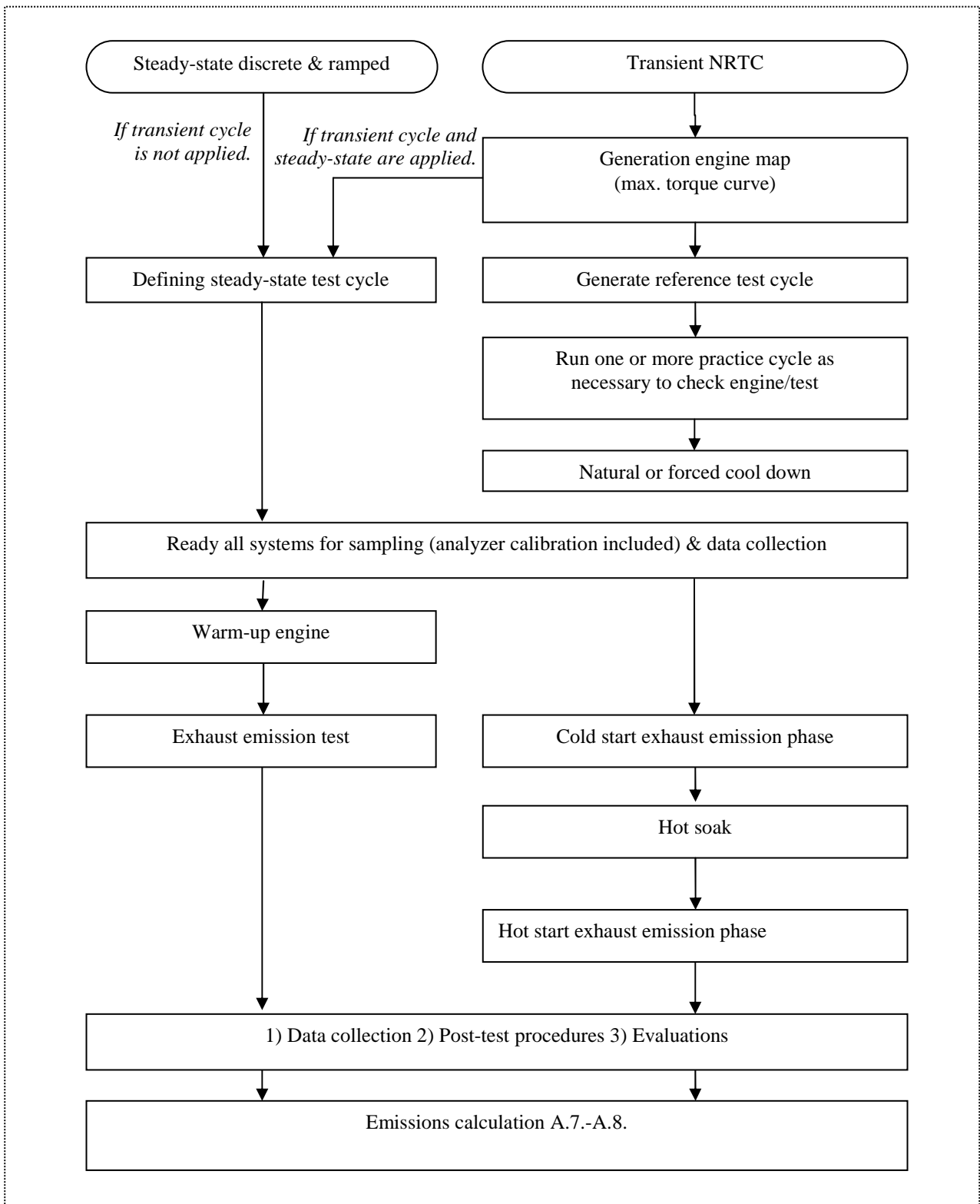

*Paragraph 7.6.*, amend to read:

"7.6. Engine mapping

Before starting the engine mapping, the engine shall be warmed up and towards the end of the warm up it shall be operated for at least 10 minutes at maximum power or according to the recommendation of the manufacturer and good engineering judgement in order to stabilize the engine coolant and lube oil temperatures. When the engine is stabilized, the engine mapping shall be performed.

Except constant speed engines, engine mapping shall be performed with fully open fuel lever or governor using discrete speeds in ascending order. The minimum and maximum mapping speeds are defined as follows:

Minimum mapping speed = warm idle speed

Maximum mapping speed =  $n_{hi} \times 1.02$  or speed where max torque drops off to zero, whichever is smaller.

Where  $n_{hi}$  is the high speed, defined as the highest engine speed where 70 per cent of the maximum power is delivered.

If the highest speed is unsafe or unrepresentative (e.g., for ungoverned engines), good engineering judgement shall be used to map up to the maximum safe speed or the maximum representative one."

*Paragraph 7.7.1.1.*, amend to read:

"7.7.1.1. Rated speed

For engines that are tested with the steady state and also the transient schedule, the denormalization speed shall be calculated according to the transient procedure (paragraphs 7.6.2. and 7.7.2.1. and figure 7.3).

If the calculated denormalization speed ( $n_{denorm}$ ) is within  $\pm 2.5$  per cent of the denormalization speed as declared by the manufacturer, the declared denormalization speed ( $n_{denorm}$ ) may be used for the emission test. If the tolerance is exceeded, the calculated denormalization speed ( $n_{denorm}$ ) shall be used for the emissions test. In case of the steady state cycle the calculated denormalization speed ( $n_{denorm}$ ) is tabled as rated speed. This means that the rated speed is replaced by the denormalization speed in the generation of the steady-state 8-mode test cycle (discrete and ramp modal), including the determination of the intermediate speed.

For engines that are not tested with the transient schedule, the rated speed of tables in Annex A.1. for the 8-mode discrete and the derived ramped mode cycle shall be calculated according to the procedure (paragraphs 7.6.1. and 7.7.2.1. and figure 7.3). The rated speed is defined in paragraph 3.1.53."

*Paragraph 7.7.2.3.*, amend to read:

"7.7.2.3. Denormalization of engine torque

...

for the respective reference speed as determined in paragraph 7.7.2.2."

*Paragraph 7.8.2.4.*, amend to read:

"7.8.2.4. Validation criteria

...

Table 7.1  
RMC Regression line tolerances

	<i>Speed</i>	<i>Torque</i>	<i>Power</i>
Standard error of estimate ( <i>SEE</i> ) of $y$ on $x$	maximum 1 per cent of rated speed	maximum 2 per cent of maximum engine torque	maximum 2 per cent of maximum engine power
Slope of the regression line, $a_1$	0.99 to 1.01	0.98 - 1.02	0.98 - 1.02
Coefficient of determination, $r^2$	minimum 0.990	minimum 0.950	minimum 0.950
$y$ intercept of the regression line, $a_0$	$\pm 1$ per cent of rated speed	$\pm 20$ Nm or 2 per cent of maximum torque whichever is greater	$\pm 4$ kW or 2 per cent of maximum power whichever is greater

..."

Paragraph 7.8.3., amend to read:

"7.8.3. Transient test cycle (NRTC)

...

Small denormalized speed values near warm idle speed may cause low-speed idle governors to activate and the engine torque to exceed the reference torque even though the operator demand is at a minimum. In such cases, it is recommended to control the dynamometer so it gives priority to follow the reference torque instead of the reference speed and let the engine govern the speed.

..."

Paragraph 7.8.3.5., amend to read:

"7.8.3.5. Validation statistics (see Annex A.2.)

Linear regression between the reference and the feedback values shall be calculated for speed, torque and power.

To minimize the biasing effect of the time lag between the reference and feedback cycle values, the entire engine speed and torque feedback signal sequence may be advanced or delayed in time with respect to the reference speed and torque sequence. If the feedback signals are shifted, both speed and torque shall be shifted by the same amount in the same direction.

The method of least squares shall be used, with the best-fit equation having the form:

$$y = a_1x + a_0 \quad (7-6)$$

Where:

$y$  = feedback value of speed ( $\text{min}^{-1}$ ), torque (Nm), or power (kW)

$a_1$  = slope of the regression line

$x$  = reference value of speed ( $\text{min}^{-1}$ ), torque (Nm), or power (kW)

$a_0$  = y intercept of the regression line

The standard error of estimate (*SEE*) of  $y$  on  $x$  and the coefficient of determination ( $r^2$ ) shall be calculated for each regression line (Annex A.2.).

It is recommended that this analysis be performed at 1 Hz. For a test to be considered valid, the criteria of table 7.2 of this paragraph shall be met.

Table 7.2  
**Regression line tolerances**

	<i>Speed</i>	<i>Torque</i>	<i>Power</i>
Standard error of estimate ( <i>SEE</i> ) of $y$ on $x$	≤ 5.0 percent of maximum test speed	≤ 10.0 per cent of maximum mapped torque	≤ 10.0 per cent of maximum mapped power
Slope of the regression line, $a_1$	0.95 to 1.03	0.83 - 1.03	0.89 - 1.03
Coefficient of determination, $r^2$	minimum 0.970	minimum 0.850	minimum 0.910
y intercept of the regression line, $a_0$	≤ ±10 per cent of idle	±20 Nm or ±2 per cent of maximum torque whichever is greater	±4 kW or ±2 per cent of maximum power whichever is greater

For regression ... specified.

Table 7.3  
Permitted point deletions from regression analysis

<i>Event</i>	<i>Conditions (n = engine speed, T = torque)</i>	<i>Permitted point deletions</i>
Minimum operator demand (idle point)	$n_{\text{ref}} = n_{\text{idle}}$ and $T_{\text{ref}} = 0$ per cent and $T_{\text{act}} > (T_{\text{ref}} - 0.02 T_{\text{maxmappedtorque}})$ and $T_{\text{act}} < (T_{\text{ref}} + 0.02 T_{\text{maxmappedtorque}})$	speed and power
Minimum operator demand	$n_{\text{act}} \leq 1.02 n_{\text{ref}}$ and $T_{\text{act}} > T_{\text{ref}}$ or $n_{\text{act}} > n_{\text{ref}}$ and $T_{\text{act}} \leq T_{\text{ref}}$ or $n_{\text{act}} > 1.02 n_{\text{ref}}$ and $T_{\text{ref}} < T_{\text{act}} \leq (T_{\text{ref}} + 0.02 T_{\text{maxmappedtorque}})$	power and either torque or speed
Maximum operator demand	$n_{\text{act}} < n_{\text{ref}}$ and $T_{\text{act}} \geq T_{\text{ref}}$ or $n_{\text{act}} \geq 0.98 n_{\text{ref}}$ and $T_{\text{act}} < T_{\text{ref}}$ or $n_{\text{act}} < 0.98 n_{\text{ref}}$ and $T_{\text{ref}} > T_{\text{act}} \geq (T_{\text{ref}} - 0.02 T_{\text{maxmappedtorque}})$	power and either torque or speed

..."

Paragraph 8.1.4.3., amend to read:

"8.1.4.3. Procedure

The following linearity verification protocol shall be used:

...

- (i) At a recording frequency of at least the minimum frequency, as specified in table 9.2, the reference value shall be measured for 30 s and the arithmetic mean of the recorded values,  $\bar{y}_i$  recorded...
- (j) Steps in paragraphs (g) through (i) of this paragraph shall be repeated until all reference quantities are measured;
- (k) The arithmetic means  $\bar{y}_i$ , and reference values,  $y_{\text{ref}i}$ , shall be used to calculate least-squares linear regression parameters and statistical values to compare to the minimum performance criteria specified in table 8.2. The calculations described in Annex A.2. shall be used."

Paragraph 8.1.8.4., figure 8.1, amend to read:

"Figure 8.1  
**Schematic diagrams for diluted exhaust flow CVS calibration**

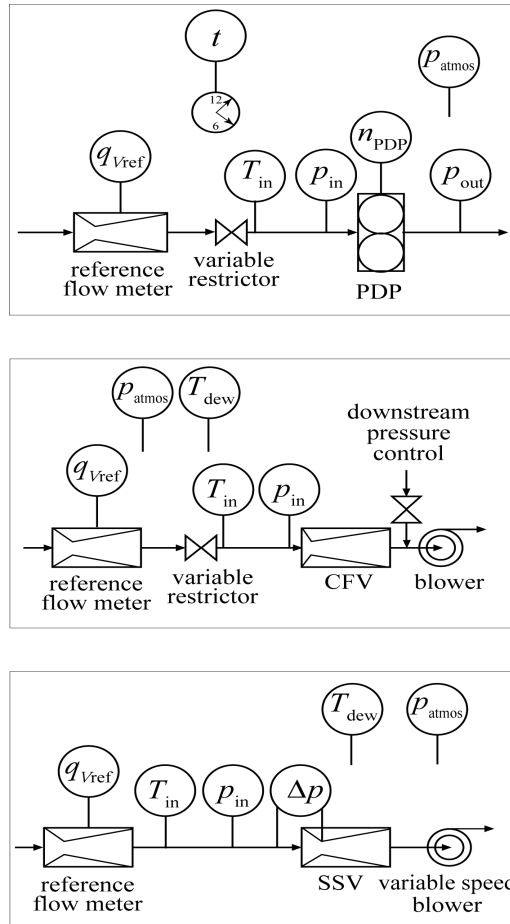

Paragraphs 8.1.8.4.2. and 8.1.8.4.3., amend to read:

"8.1.8.4.2. PDP calibration

A positive-displacement pump (PDP) shall be calibrated to determine a flow-versus-PDP speed equation that accounts for flow leakage across sealing surfaces in the PDP as a function of PDP inlet pressure. Unique equation coefficients shall be determined for each speed at which the PDP is operated. A PDP flow meter shall be calibrated as follows:

...

- (f) The PDP is operated for at least 3 minutes to stabilize the system. Then by continuously operating the PDP, the mean values of at least 30 s of sampled data of each of the following quantities are recorded:
  - (i) The mean flow rate of the reference flow meter,  $\bar{q}_{vref}$ . This may include several measurements of different quantities, such

as reference meter pressures and temperatures, for calculating  $\bar{q}_{Vref}$  ;

- (ii) The mean temperature at the PDP inlet,  $T_{in}$ ;
- (iii) The mean static absolute pressure at the PDP inlet,  $p_{in}$ ;
- (iv) The mean static absolute pressure at the PDP outlet,  $p_{out}$ ;
- (v) The mean PDP speed,  $n_{PDP}$ ;

...

#### 8.1.8.4.3. CFV calibration

A critical-flow venturi (CFV) shall be calibrated to verify its discharge coefficient,  $C_d$ , at the lowest expected static differential pressure between the CFV inlet and outlet. A CFV flow meter shall be calibrated as follows:

...

- (f) The CFV shall be operated for at least 3 minutes to stabilize the system. The CFV shall continue operating and the mean values of at least 30 s of sampled data of each of the following quantities shall be recorded:
  - (i) The mean flow rate of the reference flow meter,  $\bar{q}_{Vref}$ . This may include several measurements of different quantities, such as reference meter pressures and temperatures, for calculating  $\bar{q}_{Vref}$  ;
  - (ii) Optionally, the mean dew point of the calibration air,  $T_{dew}$ . See Annexes A.7-A.8 for permissible assumptions during emission measurements;
  - (iii) The mean temperature at the venturi inlet,  $T_{in}$ ;
  - (iv) The mean static absolute pressure at the venturi inlet,  $p_{in}$ ;
  - (v) The mean static differential pressure between the CFV inlet and the CFV outlet,  $\Delta p_{CFV}$ ;

..."

*Paragraph 8.1.8.5.1., amend to read:*

#### "8.1.8.5.1. Introduction

- (a) A propane check serves as a CVS verification to determine if there is a discrepancy in measured values of diluted exhaust flow. A propane check also serves as a batch-sampler verification to determine if there is a discrepancy in a batch sampling system that extracts a sample from a CVS, as described in paragraph (f) of this paragraph. Using good engineering judgment and safe practices, this check may be performed using a gas other than propane, such as CO<sub>2</sub> or CO. A failed propane check might indicate one or more problems that may require corrective action, as follows:

...

- (iv) The hydrocarbon contamination verification in the sample system shall be performed as described in paragraph 7.3.1.2.;

..."

*Paragraph 8.1.8.5.4., amend to read:*

"8.1.8.5.4. Preparation of the HC sampling system for the propane check

Vacuum side leak check verification of the HC sampling system may be performed according to (g) of this paragraph. If this procedure is used, the HC contamination procedure in paragraph 7.3.1.2. may be used. If the vacuum side leak check is not performed according to (g), then the HC sampling system shall be zeroed, spanned, and verified for contamination, as follows:

..."

*Paragraph 8.1.8.5.7., amend to read:*

"8.1.8.5.7. PM secondary dilution system verification

When the propane check is to be repeated to verify the PM secondary dilution system, the following procedure from (a) to (d) shall be used for this verification:

...

- (d) The reference C<sub>3</sub>H<sub>8</sub> mass shall be subtracted from the calculated mass. If this difference is within  $\pm 5$  per cent of the reference mass, the batch sampler passes this verification. If not, corrective action shall be taken."

*Paragraph 8.1.8.5.8., amend to read:*

"8.1.8.5.8. Sample dryer verification

If a humidity sensor for continuous monitoring of dew point at the sample dryer outlet is used this check does not apply, as long as it is ensured that the dryer outlet humidity is below the minimum values used for quench, interference, and compensation checks.

- (a) If a sample dryer is used as allowed in paragraph 9.3.2.3.1. to remove water from the sample gas, the performance shall be verified upon installation, after major maintenance, for thermal chiller. For osmotic membrane dryers, the performance shall be verified upon installation, after major maintenance, and within 35 days of testing;

...

- (d) The following sample dryer verification procedure method shall be used to determine sample dryer performance, or good engineering judgment shall be used to develop a different protocol:

...

- (vii) The sample dryer meets the verification if the result of paragraph (d)(vi) of this paragraph is less than the dew point corresponding to the sample dryer specifications as determined in paragraph 9.3.2.3.1. plus 2 °C or if the mol fraction from (d)(vi) is less than the corresponding sample dryer specifications plus 0.002 mol/mol or 0.2 volume per cent. Note



for this verification, sample dew point is expressed in absolute temperature, Kelvin."

*Paragraph 8.1.8.6.1.*, amend to read:

"8.1.8.6.1. Specifications for differential flow measurement

...

Acceptable accuracies of  $q_{mp}$  can be obtained by either of the following methods:

...

(c) The accuracy of  $q_{mp}$  is determined indirectly from the accuracy of the dilution ratio as determined by a tracer gas, e.g. CO<sub>2</sub>. Accuracies equivalent to method (a) for  $q_{mp}$  are required;

..."

*Paragraph 8.1.8.6.3.*, amend to read:

"8.1.8.6.3. Special requirements for differential flow measurement

A carbon flow check using actual exhaust is strongly recommended for detecting measurement and control problems and verifying the proper operation of the partial flow system. The carbon flow check should be run at least each time a new engine is installed, or something significant is changed in the test cell configuration.

..."

*Paragraph 8.1.8.7.1.*, amend to read:

"8.1.8.7.1. Scope and frequency

Upon initial sampling system installation, after major maintenance such as pre-filter changes, and within 8 hours prior to each duty-cycle sequence, it shall be verified that there are no significant vacuum-side leaks using one of the leak tests described in this section. This verification does not apply to any full-flow portion of a CVS dilution system."

*Paragraph 8.1.9.1.4.*, amend to read:

"8.1.9.1.4. Procedure

The interference verification shall be performed as follows:

...

(d) The humidified test gas shall be introduced into the sampling system. The humidified test gas may be introduced downstream of any sample dryer, if one is used during testing;

..."

*Paragraph 8.1.9.2.4.*, amend to read:

"8.1.9.2.4. Procedure

The interference verification shall be performed as follows:

...

- (c) The humidified CO<sub>2</sub> test gas shall be introduced into the sampling system. The humidified CO<sub>2</sub> test gas may be introduced downstream of any sample dryer, if one is used during testing;

..."

*Paragraph 8.1.10.1.3., amend to read:*

"8.1.10.1.3. HC FID response optimization

This procedure is only for FID analyzers that measure HC.

- (a) Instrument manufacturer requirements and good engineering judgment shall be used for initial instrument start-up and basic operating adjustment using FID fuel and zero air. Heated FIDs shall be within their required operating temperature ranges. FID response shall be optimized to meet the requirement of the hydrocarbon response factors and the oxygen interference check according to paragraphs 8.1.10.1.1.(a) and 8.1.10.2. at the most common analyzer range expected during emission testing. Higher analyzer range may be used according to the instrument manufacturer's recommendation and good engineering judgment in order to optimize FID accurately, if the common analyzer range is lower than the minimum range for the optimization specified by the instrument manufacturer;

...

- (c) The following step from (1) to (4) or the procedure instructed by the instrument manufacturer shall be taken for optimization. The procedures outlined in SAE paper No. 770141 may be optionally used for optimization;

...

- (iii) The difference between the span and zero response shall be plotted and the fuel flow adjusted to the rich side of the curve. This is the initial flow rate setting which may need further optimization depending on the results of the hydrocarbon response factors and the oxygen interference check according to paragraphs 8.1.10.1.1.(a) and 8.1.10.2;
- (iv) If the oxygen interference or the hydrocarbon response factors do not meet the following specifications, the airflow shall be incrementally adjusted above and below the manufacturer's specifications, repeating paragraphs 8.1.10.1.1.(a) and 8.1.10.2. for each flow;

..."

*Paragraph 8.1.11.2., amend to read:*

"8.1.11.2. CLD quench verification calculations

CLD quench-check calculations shall be performed as described in this paragraph."

Paragraph 8.1.11.2.3., amend to read:

"8.1.11.2.3. Combined H<sub>2</sub>O and CO<sub>2</sub> quench calculations

...

$x_{\text{H}_2\text{Omeas}}$  = measured mole fraction of water during the quench verification according to paragraph 8.1.11.1.5.(g)

$x_{\text{NOmeas}}$  = measured concentration of NO when NO span gas is blended with CO<sub>2</sub> span gas, according to paragraph 8.1.11.1.4.(j)

$x_{\text{NOact}}$  = actual concentration of NO when NO span gas is blended with CO<sub>2</sub> span gas, according to paragraph 8.1.11.1.4.(k) and calculated according to equation (8-5)

$x_{\text{CO}_2\text{exp}}$  = maximum expected concentration of CO<sub>2</sub> during emission testing, according to paragraph 8.1.11.2.2.

..."

Paragraph 8.1.11.3.4., amend to read:

"8.1.11.3.4. Procedure

The interference verification shall be performed as follows:

...

(g) This difference shall be multiplied by the ratio of the expected mean HC concentration to the HC concentration measured during the verification. The analyzer meets the interference verification of this paragraph if this result is within  $\pm 2$  per cent of the NO<sub>x</sub> concentration expected at the standard:

$$\left| \bar{x}_{\text{NO}_x, \text{CLD}, \text{meas}} - \bar{x}_{\text{NO}_x, \text{NDUV}, \text{meas}} \right| \cdot \left( \frac{\bar{x}_{\text{HC}, \text{exp}}}{\bar{x}_{\text{HC}, \text{meas}}} \right) \leq 2\% \cdot (\bar{x}_{\text{NO}_x, \text{exp}}) \quad (8-6)$$

Where:

$\bar{x}_{\text{NO}_x, \text{CLD}, \text{meas}}$  = the mean concentration of NO<sub>x</sub> measured by CLD [ $\mu\text{mol/mol}$ ] or [ppm]

$\bar{x}_{\text{NO}_x, \text{NDUV}, \text{meas}}$  = the mean concentration of NO<sub>x</sub> measured by NDUV [ $\mu\text{mol/mol}$ ] or [ppm]

$\bar{x}_{\text{HC}, \text{meas}}$  = the mean concentration of HC measured [ $\mu\text{mol/mol}$ ] or [ppm]

$\bar{x}_{\text{HC}, \text{exp}}$  = the mean concentration of HC expected at the standard [ $\mu\text{mol/mol}$ ] or [ppm]

$\bar{x}_{\text{NO}_x, \text{exp}}$  = the mean concentration of NO<sub>x</sub> expected at the standard [ $\mu\text{mol/mol}$ ] or [ppm]

...

$$\left| \bar{x}_{\text{NOx,CLD,meas}} - \bar{x}_{\text{NOx,NDUV,meas}} \right| \cdot \left( \frac{\bar{x}_{\text{HC,exp}}}{\bar{x}_{\text{HC,meas}}} \right) = |300 - 310| \times \left( \frac{40}{80} \right) = 5 \text{ ppm}$$

..."

Paragraph 8.1.12.2.5., amend to read:

"8.1.12.2.5. Correction calculation

The PM sample filter shall be corrected for buoyancy using the following equations:

$$m_{\text{cor}} = m_{\text{uncor}} \cdot \left( \frac{1 - \frac{\rho_{\text{air}}}{\rho_{\text{weight}}}}{1 - \frac{\rho_{\text{air}}}{\rho_{\text{media}}}} \right) \quad (8-8)$$

Where:

$m_{\text{cor}}$  = PM sample filter mass corrected for buoyancy

$m_{\text{uncor}}$  = PM sample filter mass uncorrected for buoyancy

...

$m_{\text{uncor}}$  = 100.000 mg

$\rho_{\text{weight}}$  = 8000 kg/m<sup>3</sup>

$\rho_{\text{media}}$  = 920 kg/m<sup>3</sup>

$$m_{\text{cor}} = m_{\text{uncor}} \cdot \left( \frac{1 - \frac{\rho_{\text{air}}}{\rho_{\text{weight}}}}{1 - \frac{\rho_{\text{air}}}{\rho_{\text{media}}}} \right) = 100.000 \times \left[ \frac{1 - \frac{1.18282}{8000}}{1 - \frac{1.18282}{920}} \right] = 100.1139 \text{ mg}$$

"

Paragraph 8.2.4.5., amend to read:

"8.2.4.5. Stabilisation of PM samples

To stabilise PM samples, they shall be placed in one or more containers that are open to the PM-stabilization environment, which is described in paragraph 9.3.4.3. A PM sample is stabilized as long as it has been in the PM-stabilization environment for one of the following durations, during which the stabilization environment has been within the specifications of paragraph 9.3.4.3.:

..."

Paragraph 9.3.2.3.1.2., amend to read:

"9.3.2.3.1.2. Type of sample dryers allowed and procedure to estimate moisture content after the dryer

Either type of sample dryer described in this paragraph to decrease the effects of water on gaseous emission measurements may be used.

- (a) If an osmotic-membrane dryer upstream of any gaseous analyzer or storage medium is used, it shall meet the temperature specifications in paragraph 9.3.2.2. ... The dew point,  $T_{\text{dew}}$ , and absolute pressure,  $p_{\text{total}}$ , downstream of an osmotic-membrane dryer shall be monitored. The amount of water shall be calculated as specified in Annexes A.7-A.8 by using continuously recorded values of  $T_{\text{dew}}$  and  $p_{\text{total}}$  or their peak values observed during a test or their alarm set points. Lacking a direct measurement, the nominal  $p_{\text{total}}$  is given by the dryer's lowest absolute pressure expected during testing;
- (b) A thermal chiller upstream of a THC measurement system for compression-ignition engines may not be used. If a thermal chiller upstream of an NO<sub>2</sub>-to-NO converter or in a sampling system without an NO<sub>2</sub>-to-NO converter is used, the chiller shall meet the NO<sub>2</sub> loss-performance check specified in paragraph 8.1.11.4. The dew point,  $T_{\text{dew}}$ , and absolute pressure,  $p_{\text{total}}$ , downstream of a thermal chiller shall be monitored. The amount of water shall be calculated as specified in Annexes A.7.-A.8 by using continuously recorded values of  $T_{\text{dew}}$  and  $p_{\text{total}}$  or their peak values observed during a test or their alarm set points. Lacking a direct measurement, the nominal  $p_{\text{total}}$  is given by the thermal chiller's lowest absolute pressure expected during testing. If it is valid to assume the degree of saturation in the thermal chiller,  $T_{\text{dew}}$  based on the known chiller efficiency and continuous monitoring of chiller temperature,  $T_{\text{chiller}}$  may be calculated. If values of  $T_{\text{chiller}}$  are not continuously recorded, its peak value observed during a test, or its alarm setpoint, may be used as a constant value to determine a constant amount of water according to Annexes A.7-A.8. If it is valid to assume that  $T_{\text{chiller}}$  is equal to  $T_{\text{dew}}$ ,  $T_{\text{chiller}}$  may be used in lieu of  $T_{\text{dew}}$  according to Annexes A.7-A.8. If it is valid to assume a constant temperature offset between  $T_{\text{chiller}}$  and  $T_{\text{dew}}$ , due to a known and fixed amount of sample reheat between the chiller outlet and the temperature measurement location, this assumed temperature offset value may be factored in into emission calculations. The validity of any assumptions allowed by this paragraph shall be shown by engineering analysis or by data."

Paragraph 9.3.2.4., table 9.1, amend to read:

"Table 9.1

**Gaseous Batch Sampling Container Materials**

CO, CO <sub>2</sub> , O <sub>2</sub> , CH <sub>4</sub> , C <sub>2</sub> H <sub>6</sub> , C <sub>3</sub> H <sub>8</sub> , NO, NO <sub>2</sub> <sup>1</sup>	polyvinyl fluoride (PVF) <sup>2</sup> for example Tedlar <sup>TM</sup> , polyvinylidene fluoride <sup>2</sup> for example Kynar <sup>TM</sup> , polytetrafluoroethylene <sup>3</sup> for example Teflon <sup>TM</sup> , or stainless steel <sup>3</sup>
THC, NMHC	polytetrafluoroethylene <sup>4</sup> or stainless steel <sup>4</sup>

<sup>1</sup> As long as aqueous condensation in storage container is prevented.

<sup>2</sup> Up to 40 °C.

<sup>3</sup> Up to 202 °C.

<sup>4</sup> At (191 ±11) °C."

Paragraph 9.4.4.1.2., amend to read:

"9.4.4.1.2. Shaft work

Work and power shall be calculated from outputs of speed and torque transducers according to paragraph 9.4.4.1. Overall systems for measuring speed and torque shall meet the calibration and verifications in paragraphs 8.1.7. and 8.1.4.

Torque induced by the inertia of accelerating and decelerating components connected to the flywheel, such as the drive shaft and dynamometer rotor, shall be compensated for as needed, based on good engineering judgment."

Paragraph 9.4.5.3.2., amend to read:

"9.4.5.3.2. Flow meter response time

For the purpose of controlling of a partial flow dilution system to extract a proportional raw exhaust sample, a flow meter response time faster than indicated in table 9.3 is required. For partial flow dilution systems with online control, the flow meter response time shall meet the specifications of paragraph 8.2.1.2."

Paragraph 9.4.7.3., amend to read:

"9.4.7.3. Gas chromatograph

Application: A gas chromatograph may be used to measure CH<sub>4</sub> concentrations of diluted exhaust for batch sampling. While also a non-methane cutter may be used to measure CH<sub>4</sub>, as described in paragraph 9.4.7.2. a reference procedure based on a gas chromatograph shall be used for comparison with any proposed alternate measurement procedure under paragraph 5.1.3."

Paragraph 9.5.1.1.(a), table 9.4, amend to read:

"Table 9.4

**Contamination limits, applicable for raw or dilute measurements [ $\mu\text{mol/mol}$  = ppm (3.2.)]**

Constituent	Purified Synthetic Air <sup>a</sup>	Purified N <sub>2</sub> <sup>a</sup>
THC (C <sub>1</sub> equivalent)	$\leq 0.05 \mu\text{mol/mol}$	$\leq 0.05 \mu\text{mol/mol}$
CO	$\leq 1 \mu\text{mol/mol}$	$\leq 1 \mu\text{mol/mol}$
CO <sub>2</sub>	$\leq 10 \mu\text{mol/mol}$	$\leq 10 \mu\text{mol/mol}$
O <sub>2</sub>	0.205 to 0.215 mol/mol	$\leq 2 \mu\text{mol/mol}$
NO <sub>x</sub>	$\leq 0.02 \mu\text{mol/mol}$	$\leq 0.02 \mu\text{mol/mol}$

<sup>a</sup> It is not required that these levels of purity are international and/or national recognized standards-traceable, long as aqueous condensation in storage container is prevented."

Paragraph A.2.1., equation (A.2-1), amend to read:

$$" \bar{y} = \frac{\sum_{i=1}^N y_i}{N} \quad (A.2-1) "$$

Paragraph A.2.8., equation (A.2-10), amend to read:

$$" SEE_y = \sqrt{\frac{\sum_{i=1}^N [y_i - a_{0y} - (a_{1y} \cdot y_{refi})]^2}{N - 2}} \quad (A.2-10) "$$

Paragraph A.4.1., amend to read:

"A.4.1. Introduction

...

Figure A.4.1 shows the sampling points at which the carbon flows shall be checked. The specific equations for the carbon flows at each of the sample points are given in the following paragraphs.

Figure A.4.1

**Measuring points for carbon flow check**

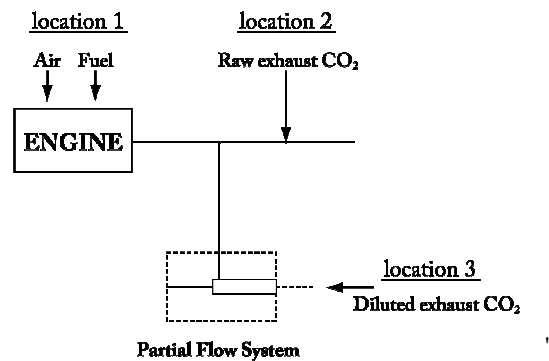

Paragraphs A.4.3. to A.4.5., amend to read:

"A.4.3. Carbon flow rate in the raw exhaust (location 2)

...

If CO<sub>2</sub> is measured on a dry basis it shall be converted to a wet basis according to paragraph A.7.3.2. or A.8.2.2."

A.4.4. Carbon flow rate in the dilution system (location 3)

...

If CO<sub>2</sub> is measured on a dry basis it shall be converted to a wet basis according to paragraph A.7.3.2. or A.8.2.2.

A.4.5. Calculation of the molar mass of the exhaust gas

The molar mass of the exhaust gas shall be calculated according to equation (A.8-15) (see paragraph A.8.2.4.2.).

..."

Paragraphs A.7.0.1., amend to read (including the existing footnotes <sup>1,7</sup>):

"A.7.0.1. General symbols

<i>Annex 7<sup>1</sup></i>	<i>Annex 8</i>	<i>Unit</i>	<i>Quantity</i>
...	...	...	...
$a_0$	$b, D_0$	t.b.d. <sup>7</sup>	y intercept of the regression line, PDP calibration intercept
$a_1$	$m$	t.b.d. <sup>7</sup>	Slope of the regression line
...	...	...	...
$\mu$	$\mu$	kg/(m·s)	Dynamic viscosity
...	...	...	...

<sup>1</sup> See subscripts; e.g.:  $\dot{m}_{air}$  for mass rate of dry air or  $\dot{m}_{fuel}$  for fuel mass rate.

<sup>7</sup> t.b.d.= to be defined."

Paragraph A.7.1.1., amend to read:

"A.7.1.1. Dry air and chemical species

...

This annex uses the following molar masses or effective molar masses of chemical species:

...

$$M_{NMHC} = 13.875389 \text{ g/mol (non-methane hydrocarbon}^{(a)})$$

$$M_{NOx} = 46.0055 \text{ g/mol (oxides of nitrogen}^{(b)})$$

...

$$M_{THC} = 13.875389 \text{ g/mol (total hydrocarbon}^{(a)})$$

(a) The effective molar masses of THC and NMHC are defined by an atomic hydrogen-to-carbon ratio,  $\alpha$ , of 1.85;

(b) The effective molar mass of  $NO_x$  is defined by the molar mass of nitrogen dioxide,  $NO_2$ .

..."

Paragraph A.7.1.4.1., amend to read:

"A.7.1.4.1. THC determination and THC/CH<sub>4</sub> initial contamination corrections

(a) If THC emissions are required to be determined,  $x_{THC[THC-FID]}$  shall be calculated by using the initial THC contamination concentration  $x_{THC[THC-FID]_{init}}$  from paragraph 7.3.1.2. as follows:

...

..."



Paragraph A.7.1.4.2., amend to read:

"A.7.1.4.2. NMHC determination

To determine NMHC concentration,  $x_{\text{NMHC}}$ , one of the following shall be used:

...

(b) For non-methane cutters,  $x_{\text{NMHC}}$  shall be calculated using the non-methane cutter's penetration fractions ( $PF$ ) of  $\text{CH}_4$  and  $\text{C}_2\text{H}_6$  from paragraph 8.1.10.3., and using the HC contamination and dry-to-wet corrected THC concentration  $x_{\text{THC}[\text{THC-FID}]_{\text{cor}}}$  as determined in paragraph (a) of A.7.1.4.1.;

(i) The following equation for penetration fractions determined using an NMC configuration as outlined in paragraph 8.1.10.3.4.1. shall be used:

$$x_{\text{NMHC}} = \frac{x_{\text{THC}[\text{THC-FID}]_{\text{cor}}} - x_{\text{THC}[\text{NMC-FID}]} \cdot RF_{\text{CH}_4[\text{THC-FID}]}}{1 - RF_{\text{C}_2\text{H}_6[\text{NMC-FID}]} \cdot RF_{\text{CH}_4[\text{THC-FID}]}} \quad (\text{A.7-6})$$

Where:

...

$x_{\text{THC}[\text{NMC-FID}]}$  = concentration of THC, HC contamination (optional) and dry-to-wet corrected, as measured by the NMC FID during sampling through the NMC

$RF_{\text{CH}_4[\text{THC-FID}]}$  = response factor of THC FID to  $\text{CH}_4$ , according to paragraph 8.1.10.1.4.

$RF_{\text{C}_2\text{H}_6[\text{NMC-FID}]}$  = non-methane cutter combined ethane response factor and penetration fraction, according to paragraph 8.1.10.3.4.1.

...

(ii) For penetration fractions determined using an NMC configuration as outlined in paragraph 8.1.10.3.4.2., the following equation shall be used:

$$x_{\text{NMHC}} = \frac{x_{\text{THC}[\text{THC-FID}]_{\text{cor}}} \cdot PF_{\text{CH}_4[\text{NMC-FID}]} - x_{\text{THC}[\text{NMC-FID}]}}{PF_{\text{CH}_4[\text{NMC-FID}]} - PF_{\text{C}_2\text{H}_6[\text{NMC-FID}]}} \quad (\text{A.7-7})$$

Where:

...

$PF_{\text{CH}_4[\text{NMC-FID}]}$  = non-methane cutter  $\text{CH}_4$  penetration fraction, according to paragraph 8.1.10.3.4.2.

$x_{\text{THC[NMC-FID]}}$  = concentration of THC, HC contamination (optional) and dry-to-wet corrected, as measured by the NMC FID during sampling through the NMC

$PF_{\text{C}_2\text{H}_6[\text{NMC-FID}]}$  = non-methane cutter ethane penetration fraction, according to paragraph 8.1.10.3.4.2.

...

- (iii) For penetration fractions determined using an NMC configuration as outlined in paragraph 8.1.10.3.4.3., the following equation shall be used:

...

Where:

...

$PF_{\text{CH}_4[\text{NMC-FID}]}$  = non-methane cutter  $\text{CH}_4$  penetration fraction, according to paragraph 8.1.10.3.4.3.

$x_{\text{THC[NMC-FID]}}$  = concentration of THC, HC contamination (optional) and dry-to-wet corrected, as measured by the NMC FID during sampling through the NMC

$RFPF_{\text{C}_2\text{H}_6[\text{NMC-FID}]}$  = non-methane cutter  $\text{CH}_4$  combined ethane response factor and penetration fraction, according to paragraph 8.1.10.3.4.3.

$RF_{\text{CH}_4[\text{THC-FID}]}$  = response factor of THC FID to  $\text{CH}_4$ , according to paragraph 8.1.10.1.4.

...

- (c) For a gas chromatograph,  $x_{\text{NMHC}}$  shall be calculated using the THC analyzer's response factor ( $RF$ ) for  $\text{CH}_4$ , from paragraph 8.1.10.1.4., and the HC contamination and dry-to-wet corrected initial THC concentration  $x_{\text{THC}[\text{THC-FID}]_{\text{cor}}}$  as determined in paragraph (a) above as follows:

..."

Paragraph A.7.2.3., amend to read:

"A.7.2.3. Chemical balance procedure

...

Use the following steps to complete a chemical balance:

- (a) Measured concentrations such as,  $x_{\text{CO}_2\text{meas}}$ ,  $x_{\text{NOmeas}}$ , and  $x_{\text{H}_2\text{Oint}}$ , shall be converted to dry concentrations by dividing them by one minus the amount of water present during their respective measurements; for example:  $x_{\text{H}_2\text{O} \times \text{CO}_2\text{meas}}$ ,  $x_{\text{H}_2\text{O} \times \text{NOmeas}}$ , and  $x_{\text{H}_2\text{Oint}}$ . If the amount of water

present during a “wet” measurement is the same as the unknown amount of water in the exhaust flow,  $x_{\text{H}_2\text{Oexh}}$ , it has to be iteratively solved for that value in the system of equations. If only total  $\text{NO}_x$  are measured and not NO and  $\text{NO}_2$  separately, good engineering judgement shall be used to estimate a split in the total  $\text{NO}_x$  concentration between NO and  $\text{NO}_2$  for the chemical balances. The molar concentration of  $\text{NO}_x$ ,  $x_{\text{NO}_x}$ , may be assumed to be 75 per cent NO and 25 per cent  $\text{NO}_2$ . For  $\text{NO}_2$  storage aftertreatment systems,  $x_{\text{NO}_x}$  may be assumed to be 25 per cent NO and 75 per cent  $\text{NO}_2$ . For calculating the mass of  $\text{NO}_x$  emissions, the molar mass of  $\text{NO}_2$  for the effective molar mass of all  $\text{NO}_x$  species, regardless of the actual  $\text{NO}_2$  fraction of  $\text{NO}_x$ , shall be used;

- (b) Equations (A.7-10 to A.7-26) in paragraph (d) of this paragraph A.7.2.3. have to be entered into a computer program to iteratively solve for  $x_{\text{H}_2\text{Oexh}}$ ,  $x_{\text{Ccombdry}}$  and  $x_{\text{dil/exh}}$ . Good engineering judgment shall be used to guess initial values for  $x_{\text{H}_2\text{Oexh}}$ ,  $x_{\text{Ccombdry}}$ , and  $x_{\text{dil/exh}}$ . Guessing an initial amount of water that is about twice the amount of water in the intake or dilution air is recommended. Guessing an initial value of  $x_{\text{Ccombdry}}$  as the sum of the measured  $\text{CO}_2$ , CO, and THC values is recommended. Guessing an initial  $x_{\text{dil}}$  between 0.75 and 0.95 ( $0.75 < x_{\text{dil}} < 0.95$ ), such as 0.8 is also recommended. Values in the system of equations shall be iterated until the most recently updated guesses are all within  $\pm 1$  per cent of their respective most recently calculated values;

...

At the end of the chemical balance, the molar flow rate  $\dot{n}_{\text{exh}}$  is calculated as specified in paragraphs A.7.3.3. and A.7.4.3."

*Paragraph A.7.3.3., amend to read:*

"A.7.3.3. Exhaust gas molar flow rate

The flow rate of the raw exhaust gases can be directly measured or can be calculated based on the chemical balance of paragraph A.7.2.3. Calculation of raw exhaust molar flow rate is performed from measured intake air molar flow rate or fuel mass flow rate. The raw exhaust molar flow rate can be calculated from the sampled emissions,  $\dot{n}_{\text{exh}}$ , based on the measured intake air molar flow rate,  $\dot{n}_{\text{int}}$ , or the measured fuel mass flow rate,  $\dot{m}_{\text{fuel}}$ , and the values calculated using the chemical balance in paragraph A.7.2.3. It shall be solved for the chemical balance in paragraph A.7.2.3. at the same frequency that  $\dot{n}_{\text{int}}$  or  $\dot{m}_{\text{fuel}}$  is updated and recorded.

..."

*Paragraph A.7.4.1., amend to read:*

"A.7.4.1. Emission mass calculation and background correction

Equations for the calculation of gaseous emissions mass  $m_{\text{gas}}$  [g/test] as a function of molar emissions flow rates are as follows:

- (a) Continuous sampling, varying flow rate

$$m_{\text{gas}} = \frac{1}{f} \cdot M_{\text{gas}} \cdot \sum_{i=1}^N \dot{n}_{\text{exhi}} \cdot x_{\text{gasi}} \quad (\text{see A.7-29})$$

Where:

$M_{\text{gas}}$  = generic emission molar mass [g/mol]

$\dot{n}_{\text{exhi}}$  = instantaneous exhaust gas molar flow rate on a wet basis [mol/s]

$x_{\text{gasi}}$  = instantaneous generic gas molar concentration on a wet basis [mol/mol]

$f$  = data sampling rate [Hz]

$N$  = number of measurements [-]

Continuous sampling, constant flow rate

$$m_{\text{gas}} = M_{\text{gas}} \cdot \dot{n}_{\text{exh}} \cdot \bar{x}_{\text{gas}} \cdot \Delta t \quad (\text{see A.7-31})$$

Where:

$M_{\text{gas}}$  = generic emission molar mass [g/mol]

$\dot{n}_{\text{exh}}$  = exhaust gas molar flow rate on a wet basis [mol/s]

$\bar{x}_{\text{gas}}$  = mean gaseous emission molar fraction on a wet basis [mol/mol]

$\Delta t$  = time duration of test interval

- (b) Batch sampling, regardless varying flow or constant rate is, the following equation shall be used:

$$m_{\text{gas}} = \frac{1}{f} \cdot M_{\text{gas}} \cdot \bar{x}_{\text{gas}} \cdot \sum_{i=1}^N \dot{n}_{\text{exhi}} \quad (\text{see A.7-32})$$

Where:

$M_{\text{gas}}$  = generic emission molar mass [g/mol]

$\dot{n}_{\text{exhi}}$  = instantaneous exhaust gas molar flow rate on a wet basis [mol/s]

$\bar{x}_{\text{gas}}$  = mean gaseous emission molar fraction on a wet basis [mol/mol]

$f$  = data sampling rate [Hz]

$N$  = number of measurements [-]

..."

Paragraph A.7.4.4.1., amend to read:

"A.7.4.4.1. Sampling

...

(b) Sampling from a constant flow rate

...

For sampling with a constant dilution ratio ( $DR$ ),  $m_{PM}$  [g] shall be calculated using the following equation:

$$m_{PM} = m_{PMdil} \cdot DR \quad (A.7-46)$$

Where:

$m_{PMdil}$  = PM mass in dilution air [g]

$DR$  = dilution ratio [-] defined as the ratio between the mass of the emission  $m$  and the mass of diluted exhaust  $m_{dil/exh}$  ( $DR = m/m_{dil/exh}$ ).

The dilution ratio  $DR$  can be expressed as a function of  $x_{dil/exh}$ :

$$DR = \frac{1}{1 - x_{dil/exh}} \quad (A.7-47)"$$

Annex A.7, Appendix 1, amend to read:

## "Annex A.7

### Appendix 1

#### Diluted exhaust flow (CVS) calibration

A.7.6. Introduction

This Appendix 1 describes the calculations for calibrating various flow meters. Paragraph A.7.6.1. of this Appendix 1 first describes how to convert reference flow meter outputs for use in the calibration equations, which are presented on a molar basis. The remaining paragraphs describe the calibration calculations that are specific to certain types of flow meters.

A.7.6.1. ...

A.7.6.2. PDP calibration calculations

...

(d) The procedure in paragraphs (a) through (c) of this paragraph shall be repeated for every speed that PDP is operated;

...

A.7.6.3. Venturi governing equations and permissible assumptions

This section describes the governing equations and permissible assumptions for calibrating a venturi and calculating flow using a venturi. Because a

subsonic venturi (SSV) and a critical-flow venturi (CFV) both operate similarly, their governing equations are nearly the same, except for the equation describing their pressure ratio,  $r$  (*i.e.*,  $r_{SSV}$  versus  $r_{CFV}$ ). These governing equations assume one-dimensional isentropic inviscid compressible flow of an ideal gas. In paragraph A.7.6.3.(d), ... Molar flow rate,  $\dot{n}$  [mol/s], shall be calculated as follows:

$$\dot{n} = C_d \cdot C_f \cdot \frac{A_t \cdot p_{in}}{\sqrt{Z \cdot M_{mix} \cdot R \cdot T_{in}}} \quad (A.7-60)$$

Where:

$C_d$  = Discharge coefficient, as determined in paragraph A.7.6.3.(a) [-]

$C_f$  = Flow coefficient, as determined in paragraph A.7.6.3.(b) [-]

...

A.7.6.4. SSV calibration

(a) Molar based approach. To calibrate an SSV flow meter the following steps shall be performed:

(i) The Reynolds number,  $Re^\#$ , for ... approximate  $\mu$ :

...

and, using the Sutherland three-coefficient viscosity model:

$$\mu = \mu_0 \left( \frac{T_{in}}{T_0} \right)^{\frac{3}{2}} \cdot \left( \frac{T_0 + S}{T_{in} + S} \right) \quad (A.7-67)$$

Where:

$\mu$  = Dynamic viscosity of calibration gas [kg/(m·s)]

$\mu_0$  = Sutherland reference viscosity [kg/(m·s)]

$S$  = Sutherland constant [K]

$T_0$  = Sutherland reference temperature [K]

$T_{in}$  = Absolute temperature at the venturi inlet [K]

...

..."

Paragraphs A.7.7.1. to A.7.7.3., amend to read:

"A.7.7.1. Scope and frequency

The calculations in this Appendix 2 are performed to determine if gas analyzer drift invalidates the results of a test interval. If drift does not invalidate the results of a test interval, the test interval's gas analyzer responses shall be corrected for drift according to this Appendix 2. The drift-corrected gas analyzer responses shall be used in all subsequent emission calculations. The acceptable threshold for gas analyzer drift over a test interval is specified in paragraph 8.2.2.2.

A.7.7.2. Correction principles

The calculations in this Appendix 2 utilize a gas analyzer's responses to reference zero and span concentrations of analytical gases, as determined sometime before and after a test interval. The calculations correct the gas analyzer's responses that were recorded during a test interval. The correction is based on an analyzer's mean responses to reference zero and span gases, and it is based on the reference concentrations of the zero and span gases themselves. Validation and correction for drift shall be performed as follows:

A.7.7.3. Drift validation

After applying all the other corrections—except drift correction—to all the gas analyzer signals, brake-specific emissions shall be calculated according to A.7.5. Then all gas analyzer signals shall be corrected for drift according to this Appendix 2. Brake-specific emissions shall be recalculated using all of the drift-corrected gas analyzer signals. The brake-specific emission results shall be validated and reported before and after drift correction according to paragraph 8.2.2.2."

Paragraph A.8.0.1., amend to read (including the existing footnote <sup>3</sup>):

"A.8.0.1. General symbols

<i>Annex 8</i>	<i>Annex 7</i>	<i>Unit</i>	<i>Quantity</i>
$b, D_0$	$a_0$	t.b.d. <sup>3</sup>	y intercept of the regression line
$m$	$a_1$	t.b.d. <sup>3</sup>	Slope of the regression line
...	...	...	...
$\mu$	$\mu$	kg/(m·s)	Dynamic viscosity
...	...	...	...

...

<sup>3</sup> t.b.d.= to be defined."

Paragraph A.8.2.1.2., amend to read:

"A.8.2.1.2. Transient and ramped modal cycles tests

The total mass per test of a gaseous emission  $m_{\text{gas}}$  [g/test] shall be calculated by multiplication of the time aligned instantaneous concentrations and exhaust gas flows and integration over the test cycle according to the following equation:

..."

Paragraph A.8.2.3., amend to read:

"A.8.2.3. NO<sub>x</sub> correction for humidity and temperature

As the NO<sub>x</sub> emission depends on ambient air conditions, the NO<sub>x</sub> concentration shall be corrected for ambient air temperature and humidity with the factors  $k_h$  [-] given in the following equation. This factor is valid for a humidity range between 0 and 25 g H<sub>2</sub>O/kg dry air.

..."

Paragraph A.8.2.4.1., table A.8.1, amend to read:

"Table A.8.1

**Raw exhaust gas  $u$  and component densities (the  $u$  figures are calculated for emission concentration expressed in ppm)**

Gas	NO <sub>x</sub>	CO	HC	CO <sub>2</sub>	O <sub>2</sub>	CH <sub>4</sub>	
$\rho_{\text{gas}}$ [kg/m <sup>3</sup> ]	2.053	1.250	0.621	1.9636	1.4277	0.716	
Fuel	$\rho_e$ [kg/m <sup>3</sup> ]	Coefficient $u_{\text{gas}}$ at $\lambda = 2$ , dry air, 273 K, 101.3 kPa					
Diesel	1.2939	0.001587	0.000966	0.000479	0.001518	0.001103	0.000553

Paragraph A.8.3.2., amend to read:

"A.8.3.2. Dry-to wet concentration conversion

All concentrations in paragraph A.8.3.2. shall be converted using equation (A.8-5) ( $c_w = k_w \cdot c_d$ )."

Paragraph A.8.3.3., table A.8.2, amend to read:

"Table A.8.2

**Diluted exhaust gas  $u$  values and component densities (the  $u$  figures are calculated for emission concentration expressed in ppm)**

Gas	NO <sub>x</sub>	CO	HC	CO <sub>2</sub>	O <sub>2</sub>	CH <sub>4</sub>	
$\rho_{\text{gas}}$ [kg/m <sup>3</sup> ]	2.053	1.250	0.621	1.9636	1.4277	0.716	
Fuel	$\rho_e$ [kg/m <sup>3</sup> ]	Coefficient $u_{\text{gas}}$ at $\lambda = 2$ , dry air, 273 K, 101.3 kPa					
Diesel	1.293	0.001588	0.000967	0.000480	0.001519	0.001104	0.000553

Paragraphs A.8.3.4.1. to A.8.3.4.3., amend to read:

"A.8.3.4.1. PDP-CVS system

The calculation of the mass of the diluted exhaust [kg/test] over the cycle is as follows, if the temperature of the diluted exhaust  $m_{ed}$  is kept within  $\pm 6$  K over the cycle by using a heat exchanger:

$$m_{ed} = 1.293 \cdot V_0 \cdot n_p \cdot \frac{p_p}{101.325} \cdot \frac{273.15}{\bar{T}} \quad (\text{A.8-36})$$



Where:

- $V_0$  = volume of gas pumped per revolution under test conditions [m<sup>3</sup>/rev]  
 $n_p$  = total revolutions of pump per test [rev/test]  
 $p_p$  = absolute pressure at pump inlet [kPa]  
 $\bar{T}$  = average temperature of the diluted exhaust gas at pump inlet [K]  
 1.293 kg/m<sup>3</sup> = air density at 273.15 K and 101.325 kPa

If a system with flow compensation is used (i.e. without heat exchanger), the mass of the diluted exhaust gas  $m_{ed,i}$  [kg] during the time interval shall be calculated as follows:

$$m_{ed,i} = 1.293 \cdot V_0 \cdot n_{p,i} \cdot \frac{p_p}{101.325} \cdot \frac{273.15}{\bar{T}} \quad (\text{A.8-37})$$

Where:

- $V_0$  = volume of gas pumped per revolution under test conditions [m<sup>3</sup>/rev]  
 $p_p$  = absolute pressure at pump inlet [kPa]  
 $n_{p,i}$  = total revolutions of pump per time interval  $i$  [rev/ $\Delta t$ ]  
 $\bar{T}$  = average temperature of the diluted exhaust gas at pump inlet [K]  
 1.293 kg/m<sup>3</sup> = air density at 273.15 K and 101.325 kPa

#### A.8.3.4.2. CFV-CVS system

The calculation of the mass flow over the cycle  $m_{ed}$  [g/test] is as follows, if the temperature of the diluted exhaust is kept within  $\pm 11$  K over the cycle by using a heat exchanger:

$$m_{ed} = \frac{1.293 \cdot t \cdot K_v \cdot p_p}{T^{0.5}} \quad (\text{A.8-38})$$

Where:

- $t$  = cycle time [s]  
 $K_v$  = calibration coefficient of the critical flow venturi for standard conditions  $\left[ \left( \sqrt{\text{K}} \cdot \text{m}^4 \cdot \text{s} \right) / \text{kg} \right]$   
 $p_p$  = absolute pressure at venturi inlet [kPa]  
 $T$  = absolute temperature at venturi inlet [K]  
 1.293 kg/m<sup>3</sup> = air density at 273.15 K and 101.325 kPa

If a system with flow compensation is used (i.e. without heat exchanger), the mass of the diluted exhaust gas  $m_{ed,i}$  [kg] during the time interval shall be calculated as follows:

$$m_{ed,i} = \frac{1.293 \cdot \Delta t_i \cdot K_v \cdot p_p}{T^{0.5}} \quad (A.8-39)$$

Where:

- $\Delta t_i$  = time interval of the test [s]  
 $K_v$  = calibration coefficient of the critical flow venturi for standard conditions  $\left[ \left( \sqrt{\text{K}} \cdot \text{m}^4 \cdot \text{s} \right) / \text{kg} \right]$   
 $p_p$  = absolute pressure at venturi inlet [kPa]  
 $T$  = absolute temperature at venturi inlet [K]  
 $1.293 \text{ kg/m}^3$  = air density at 273.15 K and 101.325 kPa

A.8.3.4.3. SSV-CVS system

The calculation of the diluted exhaust gas mass over the cycle  $m_{ed}$  [kg/test] shall be as follows, if the temperature of the diluted exhaust is kept within  $\pm 11\text{K}$  over the cycle by using a heat exchanger:

$$m_{ed} = 1.293 \cdot q_{vSSV} \cdot \Delta t \quad (A.8-40)$$

Where:

- $1.293 \text{ kg/m}^3$  = air density at 273.15 K and 101.325 kPa  
 $\Delta t$  = cycle time [s]  
 $q_{vSSV}$  = air flow rate at standard conditions (101.325 kPa, 273.15 K) [ $\text{m}^3/\text{s}$ ]

with

$$q_{vSSV} = \frac{A_0}{60} d_v^2 C_d p_p \sqrt{\left[ \frac{1}{T_{in}} \left( r_p^{1.4286} - r_p^{1.7143} \right) \cdot \left( \frac{1}{1 - r_D^4 r_p^{1.4286}} \right) \right]} \quad (A.8-41)$$

...

If a system with flow compensation is used (i.e. without heat exchanger), the mass of the diluted exhaust gas  $m_{ed,i}$  [kg] during the time interval shall be calculated as follows:

$$m_{ed,i} = 1.293 \cdot q_{vSSV} \cdot \Delta t_i \quad (A.8-42)$$

Where:

- $1.293 \text{ kg/m}^3$  = air density at 273.15 K and 101.325 kPa  
 $\Delta t_i$  = time interval [s]  
 $q_{vSSV}$  = volumetric flow rate of the SSV [ $\text{m}^3/\text{s}$ ]"

Paragraph A.8.3.5.2.2., amend to read:

"A.8.3.5.2.2. Calculation of the particulate mass flow rate

The particulate emission flow rate over the cycle  $q_{mPM}$  [g/h] shall be calculated as follows:

...

(b) For the multiple-filter method

$$q_{mPMi} = \frac{m_{fi}}{m_{sepi}} \cdot q_{medfi} \cdot \frac{3600}{1000} \quad (\text{A.8-57})$$

Where:

- $q_{mPMi}$  = particulate mass flow rate for the mode  $i$  [g/sh]  
 $m_{fi}$  = particulate sample mass collected at mode  $i$  [mg]  
 $q_{medfi}$  = equivalent diluted exhaust gas mass flow rate on wet basis at mode  $i$  [kg/s]  
 $m_{sepi}$  = mass of diluted exhaust sample passed through the particulate sampling filter at mode  $i$  [kg]

The PM mass is determined over the test cycle by summation of the average values of the individual modes  $i$  during the sampling period.

The particulate mass flow rate  $q_{mPM}$  [g/h] or  $q_{mPMi}$  [g/h] may be background corrected as follows:

(c) For the single-filter method

$$q_{mPM} = \left\{ \frac{m_f}{m_{sep}} - \left[ \frac{m_{f,d}}{m_d} \cdot \sum_{i=1}^N \left( 1 - \frac{1}{D_i} \right) \cdot WF_i \right] \right\} \cdot \overline{q_{medf}} \cdot \frac{3600}{1000} \quad (\text{A.8-58})$$

Where:

- $q_{mPM}$  = particulate mass flow rate [g/h]  
 $m_f$  = particulate sample mass collected [mg]  
 $m_{sep}$  = mass of diluted exhaust sample passed through the particulate sampling filter [kg]  
 $m_{f,d}$  = particulate sample mass of the dilution air collected [mg]  
 $m_d$  = mass of the dilution air sample passed through the particulate sampling filters [kg]  
 $D_i$  = dilution factor at mode  $i$  (see equation (A.8-29) of paragraph A.8.3.2.2.) [-]  
 $WF_i$  = weighting factor for the mode  $i$  [-]  
 $\overline{q_{medf}}$  = average equivalent diluted exhaust gas mass flow rate on wet basis [kg/s]

(d) For the multiple-filter method

$$q_{mPMi} = \left\{ \frac{m_{fi}}{m_{sepi}} - \left[ \frac{m_{f,d}}{m_d} \cdot \left( 1 - \frac{1}{D} \right) \right] \right\} \cdot q_{medfi} \cdot \frac{3600}{1000} \quad (\text{A.8-59})$$

Where:

- $q_{mPMi}$  = particulate mass flow rate at mode  $i$  [g/h]

- $m_{fi}$  = particulate sample mass collected at mode  $i$  [mg]
- $m_{sepi}$  = mass of diluted exhaust sample passed through the particulate sampling filter at mode  $i$  [kg]
- $m_{f,d}$  = particulate sample mass of the dilution air collected [mg]
- $m_d$  = mass of the dilution air sample passed through the particulate sampling filters [kg]
- $D$  = dilution factor (see equation (A.8-29) of paragraph A.8.3.2.2.) [-]
- $q_{medfi}$  = equivalent diluted exhaust gas mass flow rate on wet basis at mode  $i$  [kg/s]

If more than one measurement is made,  $m_{f,d}/m_d$  shall be replaced with  $\overline{m_{f,d}/m_d}$ ."

Paragraph A.8.4.2.1., amend to read:

"A.8.4.2.1. Transient and ramped modal cycles

The particulate specific emissions shall be calculated with equation (A.8-61) where  $e_{gas}$  [g/kWh] and  $m_{gas}$  [g/test] are substituted by  $e_{PM}$  [g/kWh] and  $m_{PM}$  [g/test] respectively:

$$e_{PM} = \frac{m_{PM}}{W_{act}} \tag{A.8-64}$$

Where:

$m_{PM}$  = total mass of particulates emission, calculated according to paragraph A.8.3.5. [g/test]

..."

Paragraphs A.8.5.1. to A.8.5.3., amend to read:

"A.8.5.1. Positive displacement pump (PDP)

...

The airflow rate ( $q_{vcvs}$ ) at each restriction setting (minimum 6 settings) shall be calculated in standard  $m^3/s$  from the flowmeter data using the manufacturer's prescribed method. The airflow rate shall then be converted to pump flow ( $V_0$ ) in  $m^3/rev$  at absolute pump inlet temperature and pressure as follows:

$$V_0 = \frac{q_{vcvs}}{n} \cdot \frac{T}{273.15} \cdot \frac{101.325}{p_p} \tag{A.8-68}$$

Where:

$q_{vcvs}$  = air flow rate at standard conditions (101.325 kPa, 273.15 K) [ $m^3/s$ ]

...

A.8.5.2. Critical flow venturi (CFV)

...

The airflow rate ( $q_{VCVS}$ ) at each restriction setting (minimum 8 settings) shall be calculated in standard  $m^3/s$  from the flowmeter data using the manufacturer's prescribed method. The calibration coefficient  $K_V$   $\left[ \left( \sqrt{K} \cdot m^4 \cdot s \right) / kg \right]$  shall be calculated from the calibration data for each setting as follows:

$$K_V = \frac{q_{VCVS} \cdot \sqrt{T}}{P_p} \quad (A.8-71)$$

Where:

$q_{VCVS}$  = air flow rate at standard conditions (101.325 kPa, 273.15 K) [m<sup>3</sup>/s]

...

A.8.5.3. Subsonic venturi (SSV)

...

The airflow rate ( $q_{VSSV}$ ) at each restriction setting (minimum 16 settings) shall be calculated in standard  $m^3/s$  from the flowmeter data using the manufacturer's prescribed method. The discharge coefficient shall be calculated from the calibration data for each setting as follows:

$$C_d = \frac{q_{VSSV}}{\frac{A_0}{60} d_v^2 P_p \sqrt{\left[ \frac{1}{T_{in,V}} (r_p^{1.4286} - r_p^{1.7143}) \left( \frac{1}{1 - r_D^4 r_p^{1.4286}} \right) \right]}} \quad (A.8-72)$$

Where:

$A_0$  = collection of constants and units conversions = 0.0056940  $\left[ \frac{m^3 \cdot K^{\frac{1}{2}} \cdot 1}{min \cdot kPa \cdot mm^2} \right]$

$q_{VCVS}$  = air flow rate at standard conditions (101.325 kPa, 273.15 K) [m<sup>3</sup>/s]

...

To determine the range of subsonic flow,  $C_d$  shall be plotted as a function of Reynolds number  $Re$ , at the SSV throat. The  $Re$  at the SSV throat shall be calculated with the following equation:

$$Re = A_1 \cdot 60 \cdot \frac{q_{VSSV}}{d_v \cdot \mu} \quad (A.8-73)$$

with

$$\mu = \frac{b \times T^{1.5}}{S + T} \quad (A.8-74)$$

Where:

$A_1$  = collection of constants and units  
 conversions =  $27.43831 \left[ \frac{\text{Kg} \cdot \text{min} \cdot \text{mm}}{\text{m}^3 \cdot \text{s} \cdot \text{m}} \right]$

$q_{vcvs}$  = air flow rate at standard conditions (101.325 kPa, 273.15 K)  
 [ $\text{m}^3/\text{s}$ ]

$d_v$  = diameter of the SSV throat [mm]

$\mu$  = absolute or dynamic viscosity of the gas [ $\text{kg}/(\text{m} \cdot \text{s})$ ]

$b$  =  $1.458 \times 10^6$  (empirical constant) [ $\text{kg}/(\text{m} \cdot \text{s} \cdot \text{K}^{0.5})$ ]

$S$  = 110.4 (empirical constant) [K]

..."

---