



**Economic and Social
Council**

Distr.
RESTRICTED

TRANS/WP.29/R.808
11 April 1997

Original: ENGLISH

ECONOMIC COMMISSION FOR EUROPE

INLAND TRANSPORT COMMITTEE

Working Party on the Construction of Vehicles
(One-hundred-and-twelfth session,
24-27 June 1997, agenda item 5.11.)

PROPOSAL FOR DRAFT SUPPLEMENT 2 TO REGULATION No. 67
(Equipment for liquefied petroleum gas)

Transmitted by the Meeting of Experts on Pollution and Energy

Note: The text reproduced below was considered by the Meeting of Experts on Pollution and Energy on the basis of document TRANS/WP.29/GRPE/R.267. The Meeting of Experts authorized the experts from the Netherlands, Italy and AEGPL to prepare modifications to this document in order to eliminate discrepancies identified during the thirty-third session of the Meeting of Experts. The relevant modifications, received from the expert from the Netherlands, were incorporated into the document by the secretariat. In addition, a modification was introduced by the secretariat in compliance with the decision by the Working Party regarding the conformity of production procedures (TRANS/WP.29/504, paras. 15 and 17). The Meeting of Experts agreed to examine the proposal formally at its thirty-fourth session, prior to its transmission to the Working Party and to the Administrative Committee AC.1 for consideration at its sixth session (TRANS/WP.29/GRPE/33, para. 39). With respect to the extent of modifications necessary, the proposal was prepared as a draft Revision 1 of the Regulation.

The distribution of documents of the Inland Transport Committee and its subsidiary bodies is limited. They are distributed only to governments, to specialized agencies and to governmental and non-governmental organizations which take part in the work of the Committee and of its subsidiary bodies, and should not be given to newspapers or periodicals.

Regulation No. 37, amend to read:

"UNIFORM PROVISIONS CONCERNING :

- I. SPECIFIC EQUIPMENT OF MOTOR VEHICLES USING LIQUEFIED PETROLEUM GASES IN THEIR PROPULSION SYSTEM;**
- II. VEHICLES WITH REGARD TO THE INSTALLATION OF SPECIFIC EQUIPMENT, FOR THE USE OF LIQUEFIED PETROLEUM GASES FOR PROPULSION, OF AN APPROVED TYPE.**

1. SCOPE

This Regulation applies to:

- 1.1. Part I. Specific equipment of motor vehicles using liquefied petroleum gases in their propulsion system;
- 1.2. Part II. Vehicles with regard to the installation of specific equipment, for the use of liquefied petroleum gases for propulsion, of an approved type.

2. DEFINITION AND CLASSIFICATION OF COMPONENTS

LPG components for use in vehicles shall be classified with regard to the maximum operating pressure and function, according to figure 1.

Class 1 High pressure parts including tubes and fittings containing liquid LPG at vapour pressure or increased vapour pressure up to 3,000 kPa.

Class 2 Low pressure parts including tubes and fittings containing vaporized LPG with a maximum operating pressure below 450 kPa and over 20 kPa above atmospheric pressure.

Class 2A Low pressure parts for a limited pressure range including tubes and fittings containing vaporized LPG with a maximum operating pressure below 120 kPa and over 20 kPa above atmospheric pressure.

Class 3 Shut-off valves and pressure relief valves, when operating in the liquid phase.

LPG components designed for a maximum operating pressure below 20 kPa above atmospheric pressure are not subjected to this Regulation.

A component can consist of several parts, each part classified in his own class with regard to maximum operating pressure and function.

- 2.1. "Pressure" means relative pressure or overpressure, unless otherwise stated.

"Operating pressure" means the pressure under normal operating conditions.

"Maximum operating pressure" means the maximum pressure in a component which might arise during operation.

"Classification pressure" means the maximum allowable operating pressure in a component according to its classification.

2.2. "Specific equipment" means:

- (a) the container,
- (b) the accessories fitted to the container,
- (c) the vaporizer/pressure regulator,
- (d) the shut-off valve,
- (e) the gas injection device or injector or gas mixing piece,
- (f) the gas dosage unit, either separate or combined with the gas injection device,
- (g) flexible hoses,
- (h) filling unit,
- (i) non-return valve,
- (j) gas-tube pressure relief valve,
- (k) filter unit,
- (l) pressure or temperature sensor,
- (m) fuel pump,
- (n) service coupling,
- (o) electronic control unit;

Figure 1: Classification with regard to max. operating pressure and function.

- 2.3. "Container" means any vessel used for the storage of liquefied petroleum gas;
- 2.3.1. A container can be:
- (i) a standard cylindrical container with a cylindrical shell, two dished ends either torispherical or elliptical and the required openings;
 - (ii) a special container: other containers than standard cylindrical containers. The dimensional characteristics are given in annex 10, appendix 5;
- 2.4. "Type of container" means containers which do not differ in respect of the dimensional characteristics as specified in annex 10;
- 2.5. "Accessories fitted to the container" means the following equipment which may be either separate or combined:
- 2.5.1. "80 per cent stop valve" means a device that limits the filling at maximum 80 per cent of the capacity of the container,
 - 2.5.2. "Level indicator" means a device to verify the level of liquid in the container,
 - 2.5.3. "Pressure relief valve (discharge valve)" means a device to limit the pressure build-up in the container,
 - 2.5.4. remotely controlled service valve with excess flow valve,
 - 2.5.5. fuel pump,
 - 2.5.6. multivalve,
 - 2.5.7. "Gas-tight housing" means a device to protect the accessories and to vent any leakages to the open air,
 - 2.5.8. power supply bushing (fuel pump/actuators),
 - 2.5.9. non-return valve;
- 2.6. "Remotely controlled service valve with excess flow valve" means a device which allows the establishment and interruption of LPG supply to the evaporator/pressure regulator; remotely controlled means that the service valve is controlled by the electronic control unit; when the engine of the vehicle is not running the valve is closed; an excess flow valve means a device to limit the flow of LPG;
- 2.7. "Fuel pump" means a device to establish the supply of liquid LPG to the engine by increasing the pressure of the container with the fuel pump supply pressure;

- 2.8. "Multivalve" means a device consisting of all or part of the accessories mentioned in paragraphs 2.5.1. to 2.5.5., 2.5.8. and 2.5.9.;
- 2.9. "Vaporizer" means a device intended to vaporize LPG from a liquid to a gaseous state;
- 2.10. "Pressure regulator" means a device intended for reducing and regulating the pressure of liquefied petroleum gas;
- 2.11. "Shut-off valve" means a device to cut off the flow of LPG;
- 2.12. "Non-return valve" means a device to allow the flow of liquid LPG in one direction and to prevent the flow of liquid LPG in the opposite direction;
- 2.13. "Gas-tube pressure relief valve" means a device to limit the pressure build up in the tubes above a pre-set value;
- 2.14. "Gas injection device or injector or gas mixing piece" means a device which establishes the liquid or vaporized LPG to enter the engine;
- 2.15. "Gas dosage unit" means a device which meters and/or distributes the gas flow to the engine and can be either combined with the gas injection device or separate.
- 2.16. "Electronic control unit" means a device which controls the LPG demand of the engine and cuts off automatically the power to the shut-off valves of the LPG-system in case of a broken fuel supply pipe caused by an accident, or by stalling of the engine;
- 2.17. "Pressure or temperature sensor" means a device which measures pressure or temperature;
- 2.18. "LPG filter unit" means a device which filters the LPG, the filter can be integrated in other components;
- 2.19. "Flexible hoses" means hoses for conveying liquefied petroleum gas in either a liquid or vapour state at various pressures from one point to another;
- 2.20. "Filling unit" means a device to allow filling of the container; the filling unit can be realised by integration in the 80% stop valve of the container or by a remote filling unit at the outside of the vehicle;
- 2.21. "Service coupling" means a coupling in the fuel line between the fuel container and the engine. If a monofuel vehicle is out of fuel the engine can be operated by means of a service fuel container which can be coupled to the service coupling;

2.22. "Fuel rail" means a pipe or duct that connects the fuel injection devices;

2.23. "Liquefied petroleum gas (LPG)" means any product essentially composed of the following hydrocarbons:
propane, propene (propylene), normal butane, isobutane, isobutylene, butene (butylene) and ethane.

European Standard EN 589:1993 specifies requirements and methods of test for automotive LPG as marketed and delivered in the countries of the members of CEN (European Committee for Standardization).

PART I

APPROVAL OF SPECIFIC EQUIPMENT OF MOTOR VEHICLES USING LIQUEFIED PETROLEUM GASES IN THEIR PROPULSION SYSTEM

3. APPLICATION FOR APPROVAL

- 3.1. The application for approval of specific equipment shall be submitted by the holder of the trade name or mark or by his duly accredited representative.
- 3.2. It shall be accompanied by the undermentioned documents in triplicate and by the following particulars:
- 3.2.1. a detailed description of the type of the specific equipment (as specified in annex 1),
- 3.2.2. a drawing of the specific equipment, sufficiently detailed and on an appropriate scale,
- 3.2.3. verification of compliance with the specifications prescribed in paragraph 6 of this Regulation;
- 3.3. At the request of the technical service responsible for conducting approval tests, samples of the specific equipment shall be provided.

Supplementary samples shall be supplied upon request.

4. MARKINGS

- 4.1. All components submitted for approval shall bear the trade name or mark of the manufacturer and the type; and for non-metallic components also the manufacturing month and year; this marking shall be clearly legible and indelible.
- 4.2. All equipment shall have a space large enough to accommodate the approval mark including the classification of the component (see annex 2A); this space shall be shown on the drawings referred to in paragraph 3.2.2. above.
- 4.3. Every container shall also bear a marking place, welded to it, with the following data clearly legible and indelible:
- (a) a serial number;
 - (b) the capacity in litres;
 - (c) the marking "LPG";
 - (d) test pressure [bar];

- (e) the wording: "maximum degree of filling: 80%";
- (f) year and month of approval (e.g. 96/01);
- (g) approval mark according to paragraph 5.4.

When a pump is mounted inside the container there shall be either a marking on the multivalve if present or a marking on the container as follows:

- (h) the marking "PUMP INSIDE" and a marking identifying the pump when a pump is mounted in the container.

5. APPROVAL

- 5.1. If the equipment samples submitted for approval meet the requirements of paragraphs 6.1. to 6.13. of this Regulation, approval of the type of equipment shall be granted.
- 5.2. An approval number shall be assigned to each type of equipment approved. Its first two digits (at present 00 for the Regulation in its original form) shall indicate the series of amendments incorporating the most recent major technical amendments made to the Regulation at the time of issue of the approval. The same Contracting Party shall not assign this alphanumeric code to another type of equipment.
- 5.3. Notice of approval or of refusal or of extension of approval of an LPG equipment type/part pursuant to this Regulation shall be communicated to the Parties to the Agreement applying this Regulation, by means of a form conforming to the model in annex 2B to this Regulation.
- 5.4. There shall be affixed, conspicuously and in the space referred to in paragraph 4.2. above, to all equipment conforming to a type approved under this Regulation, in addition to the mark prescribed in paragraphs 4.1. and 4.3., an international approval mark consisting of:

- 5.4.1. A circle surrounding the letter "E" followed by the distinguishing number of the country which has granted approval 1/.
- 5.4.2. The number of this Regulation, followed by the letter "R", a dash and the approval number to the right of the circle prescribed in paragraph 5.4.1. This approval number consists of the component type approval number which appears on the certificate completed for this type (see paragraph 5.2. and annex 2B) preceded by two figures indicating the sequence of the latest series of amendments to this Regulation.
- 5.5. The approval mark shall be clearly legible and be indelible.
- 5.6. Annex 2A to this Regulation gives examples of the arrangement of the aforesaid approval mark.

6. SPECIFICATIONS REGARDING THE VARIOUS COMPONENTS OF THE LPG EQUIPMENT

6.1. General provisions

The specific equipment of vehicles using LPG in their propulsion system shall function in a correct and safe way.

The materials of the equipment which are in contact with LPG shall be compatible with it.

Those parts of equipment whose correct and safe functioning is liable to be influenced by LPG, high pressure or vibrations has to be submitted to relevant test procedures described in the annexes of this Regulation. In particular the provisions of paragraphs 6.2. to 6.13. are to be fulfilled.

The installation of LPG-equipment approved by this regulation shall comply with relevant electromagnetic compatibility (E.M.C) requirements according to directive 95/54/EEC or equivalent.

1/ 1 for Germany, 2 for France, 3 for Italy, 4 for the Netherlands, 5 for Sweden, 6 for Belgium, 7 for Hungary, 8 for the Czech Republic, 9 for Spain, 10 for Yugoslavia, 11 for the United Kingdom, 12 for Austria, 13 for Luxembourg, 14 for Switzerland, 15 (vacant), 16 for Norway, 17 for Finland, 18 for Denmark, 19 for Romania, 20 for Poland, 21 for Portugal, 22 for the Russian Federation, 23 for Greece, 24 (vacant), 25 for Croatia, 26 for Slovenia, 27 for Slovakia, 28 for Belarus, 29 for Estonia, 30-36 (vacant) and 37 for Turkey. Subsequent numbers shall be assigned to other countries in the chronological order in which they ratify or accede to the Agreement concerning the Adoption of Uniform Conditions of Approval and Reciprocal Recognition of Approval for Motor Vehicle Equipment and Parts, and the numbers thus assigned shall be communicated by the Secretary-General of the United Nations to the Contracting Parties to the Agreement.

6.2. **Provisions regarding containers**

The LPG containers shall be type-approved pursuant to the provisions laid down in annex 10 to this Regulation.

6.3. **Provisions regarding accessories fitted to the container**

6.3.1. The container shall be equipped with the following accessories, which may be either separate or combined (multivalve(s)):

6.3.1.1. 80 per cent stop valve,

6.3.1.2. level indicator,

6.3.1.3. pressure relief valve (discharge valve),

6.3.1.4. remotely controlled service valve with excess flow valve,

6.3.2. The container may be equipped with a gas-tight housing, if necessary.

6.3.3. The container may be equipped with a power supply bushing for the sake of actuators/LPG fuel pump.

6.3.4. The container may be equipped with a LPG fuel pump inside the container.

6.3.5. The container may be equipped with a non-return valve.

6.3.6. The accessories mentioned in paragraphs 6.3.1. to 6.3.3. above shall be type-approved pursuant to the provisions laid down in annex 3 to this Regulation.

6.4. - 6.13. **Provisions regarding other components**

The other components, which are shown in Table 1, shall be type approved pursuant to the provisions laid down in the annexes which can be determined from the table.

Table 1

Paragraph	Component	Annex
6.4.	Fuel pump	4
6.5.	Vaporizer <u>1</u> / Pressure regulator <u>1</u> /	6
6.6.	Shut-off valves Non-return valves Gas-tube pressure relief valves Service couplings	7
6.7.	Flexible hoses	8
6.8.	Filling unit	9
6.9.	Gas injection devices/ Gas mixing piece <u>3</u> / or Injectors	11
6.10.	Gas dosage units <u>2</u> /	12
6.11.	Pressure sensors Temperature sensors	13
6.12.	Electronic control unit	14
6.13.	LPG filter units	5

1/ Either combined or separate

2/ Only applicable when the gas dosage actuator is not integrated in the gas injection device.

3/ Applicable only when the operating pressure of the gas mixing piece exceeds 20 kPa (Class 2).

- 6.14. **General design rules regarding components**
- 6.14.1. Provisions regarding the 80% stop valve
- 6.14.1.1. The connection between the float and the closing unit of the 80 per cent stop valve shall not be deformed under normal conditions of use.
- 6.14.1.2. If the 80 per cent stop valve of the container comprises a float, the latter shall withstand an outside pressure of 6,750 kPa.
- 6.14.1.3. The closing unit of the device that limits the filling, at maximum 80 per cent of the capacity of the container, shall withstand a pressure of 6,750 kPa. At the cut-off position, the filling rate at a differential pressure of 700 kPa shall not exceed 500 cm³/minute.
- 6.14.1.4. When the 80 stop valve does not comprise any float, it shall not be possible to continue filling, after closing-off, at a rate exceeding 500 cm³/minute.
- 6.14.1.5. The device shall bear a permanent marking, indicating the container-type for which it has been designed, diameter and angle, and if applicable mounting indication.
- 6.14.2. Electrical operated devices containing LPG shall have, to prevent in case of fracture of the component, electric sparks on the surface of fracture,
(i) insulated in a manner that no current is lead through LPG containing parts
(ii) the electrical system of the device shall be isolated:
- from the body
- from the container for the fuel pump.
Isolation resistance shall be > 10 M Ω .
- 6.14.2.1. The electrical connections inside the boot and passengers compartment shall comply with insulation class IP 40 according to DIN 40050.
- 6.14.2.2. All other electrical connections shall comply with insulation class IP 54 according to DIN 40050.
- 6.14.2.3. The power supply bushing to establish an isolated and tight electrical connection shall be of a hermetic sealed type.
- 6.14.3.1. Specific provisions on valves activated by an electric/external (hydraulic,pneumatic) power:
In the case of activated by an electric/external power (e.g. 80 per cent stop valve, service valve, shut-off valves, non return valves, gas tube pressure relief valve, service coupling), those valves shall be in "closed" position when their power is switched off.

- 6.14.3.2. The power of the fuel pump shall be switched off when the electronic control unit becomes defective or loses power.
- 6.14.4. Heat exchange medium (compatibility and pressure requirements)
 - 6.14.4.1. The materials constituting a device which are in contact with the heat exchange medium of a device when operating, shall be compatible with that fluid and shall be designed to withstand a pressure of 200 kPa of the heat exchange medium.
 - 6.14.4.2. The compartment containing the heat exchange medium of the vaporizer/pressure regulator shall be leak proof at a pressure of 200 kPa.
- 6.14.5. A component consisting of both high pressure and low pressure parts shall be so designed to prevent a pressure build up in the low pressure part above 2.25 times the maximum working pressure for which it has been tested. Components connected directly to the tank pressure shall be designed for the classification pressure of 3,000 kPa. Venting to the motor compartment or outside of the vehicle is not allowed.
- 6.14.6. Specific provisions to prevent any gasflow
 - 6.14.6.1. The pump shall be so designed that the outlet pressure never exceeds 3,000 kPa, when there is e.g. blocking of the tubing or not opening of a shut-off valve. This can be realized by switching off the pump or by recirculating to the container.
 - 6.14.6.2. The pressure regulator/vaporizer shall be so designed as to prevent any gas flow when the regulator/vaporizer unit is supplied with LPG at a pressure $\leq 4,500$ kPa when the regulator is not operating.
- 6.14.7. Provisions regarding the gas tube relief valve
 - 6.14.7.1. The gas-tube pressure relief valve shall be so designed as to open at a pressure of $3,200 \pm 200$ kPa.
 - 6.14.7.2. The gas-tube pressure relief valve shall not have internal leakage up to 3,000 kPa.
- 6.14.8. Provisions regarding the pressure relief valve (discharge valve)
 - 6.14.8.1. The pressure relief valve shall be mounted inside the container in the gaseous zone.
 - 6.14.8.2. The pressure relief valve shall be so designed as to open at a pressure of $2,500 \pm 200$ kPa.
 - 6.14.8.3. The flow capacity of the pressure relief valve, determined with compressed air at a pressure which is 20 per cent higher than the normal operating-pressure must be at least:

$Q = 10.66 A^{0.82}$, in which
 $Q = \text{m}^3/\text{min.}$ (air pressure 100 kPa absolute and 15°C).
 $A = \text{exterior surface of the container in m}^2$.

- 6.14.8.4. The pressure relief valve shall not have internal leakage up to 2,300 kPa.
- 6.14.9. Power dissipation of the fuel pump
At minimum fuel level whereby the engine is still operating the heat build-up by the fuel pump(s) should never cause the pressure relief valve to open
- 6.14.10. Provisions regarding the filling unit
- 6.14.10.1. The filling unit shall be equipped with at least one gas-tight non-return valve.
- 6.14.10.1. The filling unit shall be equipped with a cap to prevent contamination.
- 6.14.10.2. The design and dimensions of the filling unit must comply with those in the figures in annex 9. The filling point shown in figure 3 is only applicable for motor vehicles of categories M2, M3, N2, N3 and M1 having a maximum total mass > 3,500 kg. */
- 6.14.10.3. The outside filling unit is connected to the container by a hose or pipe.
- 6.14.11. Provisions regarding the level indicator
- 6.14.11.1. The device to verify the level of liquid of the container shall be of an indirect type (for example magnetic) between the inside and outside of the container. If a direct type is used the electrical power connections should meet Class 1 specifications.
- 6.14.11.2. If the level indicator of the container comprises a float, the latter shall withstand an outside pressure of 3,000 kPa.
- 6.14.12. Provisions regarding the gas tight housing of the container.
- 6.14.12.1. The gas-tight housing shall at least have one outlet with a total free cross-section of 450 mm².
- 6.14.12.2. The gas-tight housing shall be leak-proof at a pressure of 10 kPa with the aperture(s) closed off, maximum allowed leak rate of 100 cm³/h vapour and show no permanent deformation.
- 6.14.12.3. The gas-tight housing shall be designed to withstand a pressure of 50 kPa.

*/ As defined in the Consolidated Resolution on the Construction of Vehicles (R.E.3), annex 7 (document TRANS/SC1/WP29/78/Amend.3).

- 6.14.13. Provisions regarding the remotely controlled service valve with excess flow valve.
 - 6.14.13.1. Provisions regarding the service valve
 - 6.14.13.1.1. In case the service valve is combined with a LPG fuel supply pump, identification of the pump must be realised by the marking "PUMP INSIDE" and the identification of the pump either on the marking plate of the LPG container or on the multivalve if present. Electrical connections inside the LPG container shall comply with insulation class IP 40 according to DIN 40050.
 - 6.14.13.1.2. The service valve shall withstand a pressure of 6,750 kPa in the open and closed position.
 - 6.14.13.1.3. The service valve shall not, at the shut-off position, allow an internal leak rate in the flow direction. There may be leak in the back flow direction.
 - 6.14.13.2. Provisions regarding the excess flow valve
 - 6.14.13.2.1. The excess flow valve shall be mounted inside the container.
 - 6.14.13.2.2. The excess flow valve shall be designed with a bypass to allow for equalization of pressures.
 - 6.14.13.2.3. The excess flow valve shall cut off at a pressure difference over the valve of 90 kPa. At this pressure difference the flow shall not exceed 8,000 cm³/min.
 - 6.14.13.2.4. When the excess flow valve is at cut-off position, the flow through the by-pass shall not exceed 500 cm³/min. at a differential pressure of 700 kPa.

7. MODIFICATIONS OF A TYPE OF LPG EQUIPMENT AND EXTENSION OF APPROVAL

- 7.1. Every modification of a type of LPG equipment shall be notified to the administrative department which granted the type approval. The department may then either:
 - 7.1.1. consider that the modifications made are unlikely to have an appreciable adverse effect, and that the equipment still complies with the requirements; or
 - 7.1.2. Whether retesting will be partly or complete has to be established by the competent authority.

7.2. Confirmation or refusal of approval, specifying the alterations, shall be communicated by the procedure specified in paragraph 5.3. above to the Parties to the Agreement which apply this Regulation.

7.3. The competent authority issuing the extension of approval shall assign a series number to each communication form drawn up for such an extension.

8. **(Not allocated)**

9. **CONFORMITY OF PRODUCTION**

The conformity of production procedures shall comply with those set out in the Agreement, appendix 2 (E/ECE/324-E/ECE/TRANS/505/Rev.2), with the following requirements:

- 9.1. All equipment approved under this Regulation shall be so manufactured as to conform to the type approved by meeting the requirements of paragraph 6 above.
- 9.2. In order to verify that the requirements of paragraph 9.1. are met, suitable controls of production shall be carried out.
- 9.3. The minimum requirements for conformity of production control tests set forth in annexes 8, 10 and 15 of this Regulation shall be complied with.
- 9.4. The authority which has granted type approval may at any time verify the conformity control methods applied in each production facility. The normal frequency of these verifications shall be once every year.
- 9.5. Moreover, each container shall be tested at a minimum pressure of 3,000 kPa in conformity with the prescriptions of paragraph 3.3. of annex 10 to this Regulation.
- 9.6. Every hose assembly which is applied in the high pressure class (Class 1) according to the classification as prescribed in paragraph 2 of this Regulation, shall, during half a minute, be subjected to a test with gas under a pressure of 3,000 kPa.
- 9.7. For welded containers at least 1 per 200 containers and one of the remaining number has to be subjected to the radiographic examination according to annex 10, paragraph 3.4.1.
- 9.8. During production 1 of 200 containers and 1 of the remaining number has to be subjected to the above-mentioned mechanical tests as described in annex 10, paragraph 3.1.2.

10. PENALTIES FOR NON-CONFORMITY OF PRODUCTION

10.1. The approval granted in respect of a type of equipment pursuant to this Regulation may be withdrawn if the requirements laid down in paragraph 9 above are not complied with.

10.2. If a Party to the Agreement applying this Regulation withdraws an approval it has previously granted, it shall forthwith so notify the other Contracting Parties applying this Regulation, by means of a communication form conforming to the model in annex 2B to this Regulation.

11. (Not allocated)

12. PRODUCTION DEFINITELY DISCONTINUED

If the holder of the approval completely ceases to manufacture a type of equipment approved in accordance with this Regulation, he shall so inform the authority which granted the approval. Upon receiving the relevant communication, that authority shall inform thereof the other Parties to the Agreement applying this Regulation by means of a communication form conforming to the model in annex 2B to this Regulation.

13. NAMES AND ADDRESSES OF TECHNICAL SERVICES RESPONSIBLE FOR CONDUCTING APPROVAL TESTS, AND OF ADMINISTRATIVE DEPARTMENTS

The Parties to the Agreement applying this Regulation shall communicate to the United Nations Secretariat the names and addresses of the technical services responsible for conducting approval tests and of the administrative departments which grant approval and to which forms certifying approval or extension or refusal or withdrawal of approval, issued in other countries, are to be sent.

PART II**APPROVAL OF A VEHICLE
FITTED WITH SPECIFIC EQUIPMENT FOR THE USE
OF LIQUEFIED PETROLEUM GASES IN ITS PROPULSION SYSTEM
WITH REGARD TO THE INSTALLATION OF SUCH EQUIPMENT****14. DEFINITIONS**

14.1. For the purposes of Part II of this Regulation:

14.1.1. "Approval of a vehicle" means the approval of a vehicle type with regard to the installation of its specific equipment for the use of liquefied petroleum gases in its propulsion system;

14.1.2. "Vehicle type" means a category of vehicles fitted with specific equipment for the use of LPG in its propulsion system which do not differ with respect to the following conditions:

14.1.2.1. The installation of the LPG equipment;

14.1.2.2. Application of the approved LPG equipment;

14.1.2.3. The engine and vehicle characteristics as defined in paragraph 1 of annex 2D of this Regulation.

15. APPLICATION FOR APPROVAL

15.1. The application for approval of a vehicle type with regard to the installation of specific equipment for the use of liquefied petroleum gases in its propulsion system shall be submitted by the vehicle manufacturer or by his duly accredited representative.

15.2. It shall be accompanied by the undermentioned documents in triplicate: description of the vehicle comprising all the relevant particulars referred to in annex 1 to this Regulation.

15.3. A vehicle representative of the vehicle type to be approved, shall be submitted to the technical service conducting the approval tests.

16. APPROVAL

16.1. If the vehicle submitted for approval pursuant to this Regulation is provided with all the necessary specific equipment for the use of liquefied petroleum gases in its propulsion system and meets the requirements of paragraph 17 below, approval of that vehicle type shall be granted.

- 16.2. An approval number shall be assigned to each type of vehicle approved. Its first two digits shall indicate the series of amendments incorporating the most recent major technical amendments made to the Regulation at the time of issue of the approval.
- 16.3. Notice of approval or of refusal or of extension of approval of an LPG vehicle type pursuant to this Regulation shall be communicated to the Parties to the Agreement applying this Regulation, by means of a form conforming to the model in annex 2D to this Regulation.
- 16.4. There shall be affixed, conspicuously and in a readily accessible space specified on the approval form referred to in paragraph 16.2. above, to every vehicle type approved under this Regulation an international approval mark consisting of:
- 16.4.1. A circle surrounding the letter "E" followed by the distinguishing number of the country which has granted approval 1/.
- 16.4.2. The number of this Regulation, followed by the letter "R", a dash and the approval number to the right of the circle prescribed in paragraph 16.4.1.
- 16.5. If the vehicle conforms to a vehicle approved, under one or more other Regulations annexed to the Agreement, in the country which has granted approval under this Regulation, the symbol prescribed in paragraph 16.4.1 need not be repeated; in such case, the Regulation and approval numbers and the additional symbols of all the Regulations under which approval has been granted in the country which has granted approval under this Regulation shall be placed in vertical columns to the right of the symbol prescribed in paragraph 16.4.1.
- 16.6. The approval mark shall be clearly legible and be indelible.
- 16.7. The approval mark shall be placed close to or on the vehicle data plate.

1/ 1 for Germany, 2 for France, 3 for Italy, 4 for the Netherlands, 5 for Sweden, 6 for Belgium, 7 for Hungary, 8 for the Czech Republic, 9 for Spain, 10 for Yugoslavia, 11 for the United Kingdom, 12 for Austria, 13 for Luxembourg, 14 for Switzerland, 15 (vacant), 16 for Norway, 17 for Finland, 18 for Denmark, 19 for Romania, 20 for Poland, 21 for Portugal, 22 for the Russian Federation, 23 for Greece, 24 (vacant), 25 for Croatia, 26 for Slovenia, 27 for Slovakia, 28 for Belarus, 29 for Estonia, 30-36 (vacant) and 37 for Turkey. Subsequent numbers shall be assigned to other countries in the chronological order in which they ratify or accede to the Agreement concerning the Adoption of Uniform Conditions of Approval and Reciprocal Recognition of Approval for Motor Vehicle Equipment and Parts, and the numbers thus assigned shall be communicated by the Secretary-General of the United Nations to the Contracting Parties to the Agreement.

- 16.8. Annex 2C to this Regulation gives examples of the arrangement of the aforesaid approval mark.
17. **REQUIREMENTS FOR THE INSTALLATION OF SPECIFIC EQUIPMENT FOR THE USE OF LIQUEFIED PETROLEUM GASES IN THE PROPULSION SYSTEM OF A VEHICLE**
- 17.1. **General**
- 17.1.1. The LPG equipment as installed in the vehicle shall function in such a manner that the maximum operating pressure for which it has been designed and approved cannot be exceeded.
- 17.1.2. All parts of the system shall be type approved for individual parts pursuant to Part I of this Regulation.
- 17.1.3. The materials used in the system shall be suitable for use with LPG.
- 17.1.4. All parts of the system shall be fastened in a proper way.
- 17.1.5. The LPG-system shall show no leaks.
- 17.1.6. The LPG-system shall be installed such that it has the best possible protection against damage, such as damage due to moving vehicle components, collision, grit or due to the loading or unloading of the vehicle or the shifting of those loads.
- 17.1.7. All LPG-system components covered by paragraph 3 of this annex shall be installed such that it is possible to inspect them and such that the identification markings may be read, with the exception of inspection of the LPG fuel pump if it is installed in the fuel container. In that event the identification marking of the LPG fuel pump shall be stamped on the identification plate of the LPG container or on the multivalve if present. The fuel container shall have a marking that is clearly legible and indelible.
- 17.1.8. No appliances shall be connected to the LPG-system other than those strictly required for the proper operation of the engine of the motor vehicle.
- 17.1.8.1. Notwithstanding the provisions of paragraph 17.1.8., motor vehicles of categories M2, M3, N2, N3 and M1 having a maximum total mass > 3500 kg may be fitted with a heating system to heat the passenger compartment which is connected to the LPG-system.
- 17.1.8.2. The heating system referred to in paragraph 17.1.8.1. shall be permitted if, in the view of the technical services responsible for conducting type approval, the heating system is adequately protected and the required operation of the normal LPG-system is not affected.

- 17.1.8.3. Notwithstanding the provisions of paragraph 17.1.8., a monofuel vehicle without limp-home system may be equipped with a service coupling in the LPG-system.
- 17.1.8.4. The service coupling referred to in paragraph 17.1.8.3. shall be permitted if, in the view of the technical services responsible for conducting type approval, the service coupling is adequately protected and the required operation of the normal LPG-system is not affected. The service coupling must be combined with a separate gas-tight non-return valve whereby it is only possible to operate the engine.
- 17.1.8.5. Monofuel vehicles installed with a service coupling shall carry a sticker near the service coupling as specified in appendix 17.
- 17.1.9. Identification of LPG-fuelled buses.
 - 17.1.9.1. Buses equipped with an LPG-system shall carry a plate as specified in appendix 16.
 - 17.1.9.2. The plate shall be installed on the front and rear of the bus and on the outside of the doors on the right-hand side for right hand drive vehicles and on the right-hand side for left hand drive vehicles.
- 17.2. **Further requirements**
 - 17.2.1. No component of the LPG-system, including any protective materials which form part of such components, shall project beyond the outline of the vehicle, with the exception of the filling unit if this does not project more than 10 mm beyond its point of attachment.
 - 17.2.2. With the exception of the LPG fuel container, in no cross section of the vehicle any component of the LPG-system, including any protective material which forms part of such components, may extend beyond the lower edge of the vehicle unless another part of the vehicle, within a radius of 150 mm is situated lower.
 - 17.2.3. No component of the LPG-system shall be located within 100 mm of the exhaust or similar heat source, unless such components are adequately shielded against heat.
- 17.3. **The LPG-system**
 - 17.3.1. An LPG-system shall contain at least the following components:
 - 17.3.1.1. fuel container;
 - 17.3.1.2. 80 per cent stop valve;
 - 17.3.1.3. level indicator;

- 17.3.1.4. pressure relief valve;
- 17.3.1.5. remotely controlled service valve with excess flow valve;
- 17.3.1.6. pressure regulator and vaporizer, which may be combined;
- 17.3.1.7. remotely controlled shut-off valve;
- 17.3.1.8. filling unit;
- 17.3.1.9. gas tubes and hoses;
- 17.3.1.10. gas-carrying connections between the LPG-system components;
- 17.3.1.11. injector or gas injection device or gas mixing piece;
- 17.3.1.12. electronic control unit
- 17.3.2. The system may also include the following components:
 - 17.3.2.1. gastight housing, covering the accessories fitted to the fuel container;
 - 17.3.2.2. non-return valve;
 - 17.3.2.3. gas tube pressure relief valve;
 - 17.3.2.4. gas dosage unit;
 - 17.3.2.5. LPG filter unit;
 - 17.3.2.6. pressure or temperature sensor;
 - 17.3.2.7. LPG fuel pump;
 - 17.3.2.8. power supply bushing for the container (actuators/fuel pump);
 - 17.3.2.9. service coupling (monofuel vehicles only & no limp-home system);
 - 17.3.2.10. fuel selection system and electrical system;
 - 17.3.2.11. fuel rail.
- 17.3.3. The container fittings referred to in paragraphs 17.3.1.2. to 17.3.1.5. may be combined.
- 17.3.4. The remotely controlled shut-off valve referred to in paragraph 17.3.1.7. may be combined with the pressure regulator/vaporizer.
- 17.3.5. Additional components required for the effective operation of the engine may be installed in that part of the LPG-system where the pressure is less than 20 kPa.

17.4. **Installation of the fuel container**

- 17.4.1. The fuel container shall be permanently installed in the vehicle and shall not be installed in the engine compartment.
- 17.4.2. The fuel container shall be installed in the correct position, according to the instructions from the container manufacturer.
- 17.4.3. The fuel container shall be installed such that there is no metal to metal contact, other than at the permanent fixing points of the container.
- 17.4.4. The fuel container shall have permanent fixing points to secure it to the motor vehicle or the container shall be secured to the motor vehicle by a container frame and container straps.
- 17.4.5. When the vehicle is ready for use the fuel container shall not be less than 250 mm above the road surface.
- 17.4.5.1. The provisions of paragraph 17.4.5. shall not apply if the container is adequately protected, at the front and the sides and no part of the container is located lower than this protective structure.
- 17.4.6. The connection to the motor vehicle shall be constructed such that it can withstand a force, measured through the centre of gravity of the LPG container, of sixteen (16) times the product of the gravitational force (g) and the mass of the filled LPG container in the longitudinal direction and eight (8) times that product in the transversal and vertical direction of the vehicle.
- 17.4.6.1. The provisions of paragraph 17.4.6. shall be deemed to be met if the connection to the vehicle:
- (i) comprises at least four bolts:
 - (ii) includes washers or plates if the body panels at that location are single thickness; and
- these bolts and washers or plates, assuming that the material grade is St 37 and the fixing bolts are of class 8.8, have at least the dimensions specified in Table 2.

Table 2

Container content more than - up to (l)	Minimum dimensions of the washers or plates (mm)	Minimum bolt diameter (mm)
- 100	round: 30 x 1.5 round: 25 x 2.5	8
100 150	round: 50 x 2 round: 30 x 3	10
150 -	the design shall meet the provisions of paragraph 17.4.6.	

- 17.4.6.2. There shall be no compressible materials at the connection, unless the connection fulfils the provisions of paragraph 17.4.6.
- 17.4.6.3. If the fuel container is installed, behind a seat, a total clearance of at least 100 mm, in the longitudinal direction of the vehicle, shall be provided. This clearance may be divided between the container and the rear panel of the vehicle and between the container and the seat, the shortest measured gap(s) being decisive.
- 17.4.6.4. When the container mounting differs from the provisions given in paragraphs 17.4.6.1. to 17.4.6.3., the manufacturer must supply data which clearly demonstrate that the provisions of paragraphs 17.4.5. and 17.4.6. are met.
- 17.5. **Further requirements to the fuel container**
- 17.5.1. If more than one LPG container is connected to a single delivery tube each container shall be fitted with a non-return valve installed downstream of the remotely controlled service valve and a tube pressure relief valve shall be installed in the delivery tube, downstream of the non-return valve. An adequate filter system has to be placed upstream of the non-return valve(s) to prevent fouling of the non-return valve(s).
- 17.5.2. A non-return valve and tube pressure relief valve shall not be required if the backflow pressure of the remotely controlled service valve in the closed position exceeds 500 kPa. In that case the control of the remotely controlled service valves shall be constructed such that it is impossible for more than one remotely controlled valve to be open at any time. The overlap time to allow switching is limited to two minutes.
- 17.6. **Container frame**
- 17.6.1. If the fuel container is secured to the motor vehicle by a container frame and container straps the container straps shall meet the provisions of paragraphs 17.6.2. to 17.6.9.

- 17.6.2. The fuel container shall not be secured by cables (wire ropes).
- 17.6.3. The fuel container shall be secured to the container frame by at least two container straps.
- 17.6.4. If the container straps also carry the weight of the fuel container at least three container straps shall be provided.
- 17.6.5. The container straps shall ensure that the fuel container will not slide, rotate or be dislodged.
- 17.6.6. A protective material such as felt, leather or plastic shall be interposed between the fuel container and the container straps.
- 17.6.7. The container straps shall enclose the full or almost full circumference of the container, in so far as this is not enclosed by the container frame.
- 17.6.8. A fuel container secured to a motor vehicle by a container frame and container straps shall not move significantly if the container is subjected to a force, measured through the centre of gravity of the container, of sixteen (16) times the product of the gravitational force (g) and the mass of the filled LPG container in the longitudinal direction and eight (8) times that product in the transversal and vertical direction of the vehicle.
- 17.6.9. The provisions of paragraph 17.6.8. shall be deemed to be fulfilled:
- 17.6.9.1. If the container straps, assuming that the material type is St 37, and the securing bolts, assuming that they are grade 8.8, have at least the dimensions specified in Table 3; and
- 17.6.9.2. If it is shown through calculation or testing that the fastening is of sufficient strength and can absorb sufficient energy. This latter requirement means that the elongation before breaking has to be at least 10%.
- 17.6.9.3. If the fuel container is installed longitudinally on the vehicle; if a transverse connection is present at the front of the container frame which:
- (i) is of at least the thickness of the container frame;
 - (ii) is at least 30 mm high and its top is at least 30 mm above the bottom of the container; and
 - (iii) is as close as possible, or even within, the domed end of the container.

By 'installed longitudinally' is meant that the axis of the fuel container makes an angle of no more than 30 degrees with the longitudinal centre plane of the vehicle.

Table 3

Container content more than - up to (l)	Minimum dimensions of the container straps (mm)	Minimum bolt diameter (mm)
- 85	20 x 3 or	8
85 100	30 x 3 20 x 3 <u>*/</u>	10 8 <u>*/</u>
100 150	50 x 6 50 x 3 <u>**/</u>	12 10 <u>**/</u>
150 -	the design shall meet the provisions of paragraph 17.4.6.	

*/ In this case the fuel container shall be secured by at least three container straps.

**/ In this case the fuel container shall be secured by at least four container straps.

17.7. **Accessories to the fuel container**

17.7.1. Remotely controlled service valve with excess flow valve on the container

17.7.1.1. The remotely controlled service valve with excess flow valve shall be installed directly on the fuel container, without any intervening fittings.

17.7.1.2. The remotely controlled service valve with excess flow valve shall be controlled such that it is automatically closed when the engine is not running, irrespective of the position of the ignition switch, and shall remain closed as long as the engine is not running.

17.7.2. Spring-loaded pressure relief valve in the container

17.7.2.1. The spring-loaded pressure relief valve shall be installed in the fuel container in such a manner that it is connected to the vapour space and can discharge to the surrounding atmosphere. The spring-loaded pressure relief valve may discharge into the gastight housing if that gastight housing fulfils the requirements of paragraph 17.7.5.

17.7.3. 80 per cent stop valve

17.7.3.1. The automatic filling level limiter shall be suitable for the fuel container it is fitted to and shall be installed in the appropriate position to ensure that the container cannot be filled to more than 80%.

17.7.4. Level indicator

17.7.4.1. The level indicator shall be suitable for the fuel container it is fitted to and shall be installed in the appropriate position.

17.7.5 Gastight housing on the container

17.7.5.1. A gastight housing over the container fittings, which fulfils the requirements of paragraphs 17.7.5.2. to 17.7.5.5. shall be fitted to the fuel container, unless the container is installed outside the vehicle and the container fittings are protected against dirt and water.

17.7.5.2. The gastight housing shall be in open connection with the atmosphere, where necessary through a connecting hose and a lead-through which shall be resistant against LPG.

17.7.5.3. The ventilation opening of the gastight housing shall point downwards at the point of exit from the motor vehicle. However, it shall not discharge into a wheel arch, nor shall it be aimed at a heat source such as the exhaust.

17.7.5.4. Any connecting hose and lead-through in the bottom of the bodywork of the motor vehicle for ventilation of the gastight housing shall have a minimum clear opening of 450 mm².
If a gas tube, other tube or any electrical wiring is installed in the connecting hose and lead-through, the clear opening shall also be at least 450 mm².

17.7.5.5. The housing over the container fittings and connecting hoses shall be gastight at a pressure of 10 kPa. When subjected to the test pressure, they shall not show any permanent deformations and never result in a leak.

17.7.5.6. The connecting hose shall be secured in a proper way to the gastight housing and the lead-through to ensure that a gastight joint is formed.

17.8. **Gas tubes and gas hoses**

17.8.1. Gas tubes shall be made of seamless stainless steel or seamless copper.

17.8.2. If seamless copper is used the tube shall be protected by a rubber or plastic sleeve.

- 17.8.3. The outer diameter of the gas tube shall not exceed 12 mm and the wall thickness of the gas tube shall be at least 0.8 mm.
- 17.8.4. The gas tube may be made of a non-metallic material if the tube fulfils the requirements of this Regulation, paragraph 6.7.
- 17.8.5. The gas tube may be replaced by a gas hose if this hose fulfils the requirement of this Regulation, paragraph 6.7.
- 17.8.6. Gas tubes, other than non-metallic gas tubes, shall be secured such that they shall not be subjected to vibration or stresses.
- 17.8.7. Gas hoses and non-metallic gas tubes shall be secured such that they shall not be subjected to stresses.
- 17.8.8. At the fixing point the gas tube or hose shall be fitted with a protective material.
- 17.8.9. Gas tubes or hoses shall not be located at jacking points.
- 17.8.10. At passages the gas tubes or hoses, whether or not fitted with a protective sleeve, shall be fitted with protective material.
- 17.9. **Gas connections between the components of the LPG-system**
- 17.9.1. Soldered or welded joints and bite-type compression joints are not permitted.
- 17.9.2. Stainless steel tubes shall only be joined by stainless steel fittings.
- 17.9.3. Copper tubes shall only be joined by fittings of corrosion-resistant material.
- 17.9.4. Distributing-blocks shall be made of corrosion-resistant material.
- 17.9.5. Gas tubes shall be connected by appropriate joints, for example, two-part compression joints in steel tubes and joints with olives tapered on both sides or two flanges in copper tubes. Gas tubes shall be connected with appropriate connections. Under no circumstances couplings may be used whereby the tube will be damaged. The burst pressure of the mounted couplings shall be the same or higher as specified for the tube.
- 17.9.6. The number of joints shall be limited to a minimum.
- 17.9.7. Any joints shall be made in locations where access is possible for inspection.
- 17.9.8. In a passenger compartment or enclosed luggage compartment the gas tube or hose shall be no longer than reasonably required.

- 17.9.8.1. For the purposes of paragraph 17.9.8., a gas tube or hose which is no longer than reasonably required shall be a tube or hose which does not extend further than from the fuel container to the side of the vehicle.
- 17.9.8.2. There shall be no gas-conveying connections in the passenger compartment or enclosed luggage compartment with the exception of:
 - (i) the connections on the gastight housing; and
 - (ii) the connection between the gas tube or hose and the filling unit if this connection is fitted with a sleeve which is resistant against LPG and any leaking gas will be discharged directly into the atmosphere.
- 17.9.8.3. The provisions of paragraph 17.9.8. and paragraph 17.9.8.2. shall not apply if the vehicle is a bus and the gas tubes or hoses and connections are fitted with a sleeve which is resistant against LPG and which has an open connection to the atmosphere. The open end of the sleeve or ducting shall be situated at the lowest point.
- 17.10. **Remotely controlled shut-off valve**
 - 17.10.1. A remotely controlled shut-off valve shall be installed in the gas tube from the LPG container to the pressure regulator/vaporizer, as close as possible to the pressure regulator/vaporizer.
 - 17.10.2. The remotely controlled shut-off valve may be incorporated into the pressure regulator/vaporizer.
 - 17.10.3. Notwithstanding the provisions of paragraph 17.10.1., the remotely controlled shut-off valve may be installed at a location in the engine bay specified by the manufacturer of the LPG-system if a fuel return system is provided between the pressure regulator and the LPG container.
 - 17.10.4. The remotely controlled shut-off valve shall be installed such that the fuel supply is cut off when the engine is switched off by the ignition or, if the vehicle is also equipped with another fuel system, when the other fuel is selected.
- 17.11. **Filling unit**
 - 17.11.1. The filling unit shall be secured against rotation and shall be protected against dirt and water.
 - 17.11.2. When the LPG container is installed in the passenger compartment or an enclosed (luggage) compartment, the filling unit shall be located at the outside of the vehicle.

17.12. Fuel selection system and electrical installation

- 17.12.1. The electrical components of the LPG-system shall be protected against overloads and at least one separate fuse shall be provided in the supply cable.
- 17.12.1.1. The fuse shall be installed in a known location where it can be reached without the use of tools.
- 17.12.2. The electrical power to LPG-system components which also carry gas may not be conducted by a gas tube.
- 17.12.3. All electrical components installed in a part of the LPG-system where the pressure exceeds 20 kPa shall be connected and insulated in a manner that no current is led through LPG containing parts.
- 17.12.4. Electrical cables shall be adequately protected against damage. The electrical connections inside the boot and passengers compartment shall comply with insulation class IP 40 according to DIN 40050. All other electrical connections shall comply with insulation class IP 54 according to DIN 40050.
- 17.12.5. Vehicles with more than one fuel system shall have a fuel selection system to ensure that no more than one fuel is supplied to the engine at any time. A short overlap time to allow switching-over is allowed.
- 17.12.6. Notwithstanding the provisions of paragraph 17.12.5. in the case of pilot operated dual fuel engines, it is permitted to supply more than one fuel.
- 17.12.7. The electrical connections and components in the gastight housing shall be constructed such that no sparks are generated.

18. CONFORMITY OF PRODUCTION

The conformity of production procedures shall comply with those set out in the Agreement, appendix 2 (E/ECE/324-E/ECE/TRANS/505/Rev.2) with the following requirements:

- 18.1. All vehicles approved under this Regulation shall be so manufactured as to conform to the type approved by meeting the requirements of paragraph 16 above.
- 18.2. In order to verify that the requirements of paragraph 18.1. are met, suitable controls of the production shall be carried out.
- 18.3. The authority which has granted type approval may at any time verify the conformity control methods applied in each production facility. The normal frequency of these verifications shall be once every year.

19. PENALTIES FOR NON-CONFORMITY OF PRODUCTION

- 19.1. The approval granted in respect of a type of vehicle pursuant to this Regulation may be withdrawn if the requirements laid down in paragraph 18 above are not complied with.
- 19.2. If a Party to the Agreement applying this Regulation withdraws an approval it has previously granted, it shall forthwith so notify the other Contracting Parties applying this Regulation, by means of a communication form conforming to the model in annex 2D to this Regulation.

20. MODIFICATION AND EXTENSION OF APPROVAL OF A VEHICLE TYPE

- 20.1. Every modification of the installation of the specific equipment for the use of liquefied petroleum gases in the propulsion system of the vehicle shall be notified to the administrative department which approved the vehicle type. The department may then either:
- 20.1.1. Consider that the modifications made are unlikely to have an appreciably adverse effect and that in any case the vehicle still complies with the requirements; or
- 20.1.2. Require a further test report from the technical service responsible for conducting the tests.
- 20.2. Confirmation or refusal of approval, specifying the alteration, shall be communicated by the procedure specified in paragraph 16.3. above to the Parties to the Agreement applying this Regulation.
- 20.3. The competent authority issuing the extension of approval shall assign a series number for such an extension and inform thereof the other Parties to the 1958 Agreement applying this Regulation by means of a communication form conforming to the model in annex 2D to this Regulation.

21. PRODUCTION DEFINITELY DISCONTINUED

If the holder of the approval completely ceases to manufacture a type of vehicle approved in accordance with this Regulation, he shall so inform the authority which granted the approval. Upon receiving the relevant communication, that authority shall inform thereof the other Parties to the Agreement applying this Regulation by means of a communication form conforming to the model in annex 2D to this Regulation.

**22. NAMES AND ADDRESSES OF TECHNICAL SERVICES RESPONSIBLE FOR
CONDUCTING APPROVAL TESTS, AND OF ADMINISTRATIVE DEPARTMENTS**

The Parties to the Agreement applying this Regulation shall communicate to the United Nations Secretariat the names and addresses of the technical services responsible for conducting approval tests and of the administrative departments which grant approval and to which forms certifying approval or extension or refusal or withdrawal of approval, issued in other countries, are to be sent.

Annex 1

ESSENTIAL CHARACTERISTICS OF THE VEHICLE, ENGINE AND LPG-RELATED EQUIPMENT

0. DESCRIPTION OF THE VEHICLE(S)

- 0.1. Make:
- 0.2. Type(s)
- 0.3. Name and address of the manufacturer
- 0.4. Engine type(s) and approval No.(s):

1. DESCRIPTION OF THE ENGINE(S)

- 1.1. Manufacturer
 - 1.1.1. Manufacturer's engine code(s) (as marked on the engine, or other means of identification)
- 1.2. Internal combustion engine
 - 1.2.4.5. LPG fuelling equipment: yes/no 1/
 - 1.2.4.5.1. **System description:**
 - 1.2.4.5.1.1. Make(s):
 - 1.2.4.5.1.2. Type(s):
 - 1.2.4.5.1.3. Drawings/flow charts of the installation in the vehicle(s):
 - 1.2.4.5.2. **Vaporizer/pressure regulator(s):**
 - 1.2.4.5.2.1. Make(s):
 - 1.2.4.5.2.2. Type(s):
 - 1.2.4.5.2.3. Certification number:
 - 1.2.4.5.2.4. Identification:
 - 1.2.4.5.2.5. Drawings:
 - 1.2.4.5.2.6. Number of main adjustment points
 - 1.2.4.5.2.7. Description of principle of adjustment through main adjustment points:

- 1.2.4.5.2.8. Number of idle adjustment points:
- 1.2.4.5.2.9. Description of principles of adjustment through idle adjustment points:
- 1.2.4.5.2.10. Other adjustment possibilities: if so and which (description and drawings):
- 1.2.4.5.2.11. Operating pressure(s): 2/ kPa
- 1.2.4.5.3. **Mixing piece: yes/no 1**
- 1.2.4.5.3.1. Number:
- 1.2.4.5.3.2. Make(s):
- 1.2.4.5.3.3. Type(s):
- 1.2.4.5.3.4. Drawings:
- 1.2.4.5.3.5. Place of installation (include drawing(s)):
- 1.2.4.5.3.6. Adjustment possibilities:
- 1.2.4.5.3.7. Operating pressure(s): 2/ kPa
- 1.2.4.5.4. **Gas dosage unit: yes/no 1**
- 1.2.4.5.4.1. Number:
- 1.2.4.5.4.2. Make(s):
- 1.2.4.5.4.3. Type(s):
- 1.2.4.5.4.4. Drawings:
- 1.2.4.5.4.5. Place of installation (include drawing(s)):
- 1.2.4.5.4.6. Adjustment possibilities (description)
- 1.2.4.5.4.7. Operating pressure(s): 2/ kPa
- 1.2.4.5.5. **Gas injection device (s) or Injector(s): yes/no 1**
- 1.2.4.5.5.1. Make(s):
- 1.2.4.5.5.2. Type(s):
- 1.2.4.5.5.3. Identification
- 1.2.4.5.5.4. Operating pressure(s): 2/ kPa

- 1.2.4.5.5.5. Drawings of installation: kPa
- 1.2.4.5.6. **Electronic Control Unit LPG-fuelling:**
- 1.2.4.5.6.1. Make(s):
- 1.2.4.5.6.2. Type(s):
- 1.2.4.5.6.3. Place of installation
- 1.2.4.5.6.4. Adjustment possibilities:
- 1.2.4.5.7. **LPG container:**
- 1.2.4.5.7.1. Make(s):
- 1.2.4.5.7.2. Type(s) (include drawings):
- 1.2.4.5.7.3. Number of containers:
- 1.2.4.5.7.4. Capacity: litres
- 1.2.4.5.7.5. LPG fuel pump in container: yes/no 1/
- 1.2.4.5.7.6. Certification number:
- 1.2.4.5.7.7. Drawings of the installation of the container:
- 1.2.4.5.8. **LPG container accessories**
- 1.2.4.5.8.1. 80 % stop valve:
- 1.2.4.5.8.1.1. Make(s):
- 1.2.4.5.8.1.2. Type(s):
- 1.2.4.5.8.1.3. Operating principle: float/other 1/ (include description or drawings)
- 1.2.4.5.8.2. Level indicator:
- 1.2.4.5.8.2.1. Make(s):
- 1.2.4.5.8.2.2. Type(s):
- 1.2.4.5.8.2.3. Operating principle: float/other 1/ (include description or drawings)
- 1.2.4.5.8.3. Pressure relief valve (discharge valve):
- 1.2.4.5.8.3.1. Make(s):

- 1.2.4.5.8.3.2. Type(s):
- 1.2.4.5.8.4. Remotely controlled service valve with excess flow valve:
- 1.2.4.5.8.4.1. Make(s):
- 1.2.4.5.8.4.2. Type(s):
- 1.2.4.5.8.5. Multivalve: yes/no 1/
- 1.2.4.5.8.5.1. Make(s):
- 1.2.4.5.8.5.2. Type(s):
- 1.2.4.5.8.5.3. Multivalve description (include drawings)
- 1.2.4.5.8.6. Gas-tight housing:
- 1.2.4.5.8.6.1. Make(s):
- 1.2.4.5.8.6.2. Type(s):
- 1.2.4.5.8.7. Power supply bushing (fuel pump/actuators):
- 1.2.4.5.8.7.1. Make(s):
- 1.2.4.5.8.7.2. Type(s):
- 1.2.4.5.8.7.3. Drawings:
- 1.2.4.5.9. **Fuel pump (LPG): yes/no 1/**
- 1.2.4.5.9.1. Make(s):
- 1.2.4.5.9.2. Type(s):
- 1.2.4.5.9.3. Pump mounted in LPG container: yes/no 1/
- 1.2.4.5.9.4. Operating pressure(s): 2/ kPa
- 1.2.4.5.10. **Shut-off valve/Non-return valve/Gas tube pressure relief valve: yes/no 1/**
- 1.2.4.5.10.1. Make(s):
- 1.2.4.5.10.2. Type(s):
- 1.2.4.5.10.3. Description and drawings:
- 1.2.4.5.10.4. Operating pressure(s): 2/ kPa

- 1.2.4.5.11. **Remote filling unit: 1/**
- 1.2.4.5.11.1. Make(s):
- 1.2.4.5.11.2. Type(s):
- 1.2.4.5.11.3. Description and drawings:
- 1.2.4.5.12. **Flexible fuel hose(s)/pipes:**
- 1.2.4.5.12.1. Make(s):
- 1.2.4.5.12.2. Type(s):
- 1.2.4.5.12.3. Description :
- 1.2.4.5.12.4. Operating pressure(s): 2/ kPa
- 1.2.4.5.12. **Pressure and Temperature sensor(s): 1/**
- 1.2.4.5.12.1. Make(s):
- 1.2.4.5.12.2. Type(s):
- 1.2.4.5.12.3. Description :
- 1.2.4.5.12.4. Operating pressure(s): 2/ kPa
- 1.2.4.5.12. **LPG filter unit(s): 1/**
- 1.2.4.5.12.1. Make(s):
- 1.2.4.5.12.2. Type(s):
- 1.2.4.5.12.3. Description :
- 1.2.4.5.12.4. Operating pressure(s): 2/ kPa
- 1.2.4.5.13. **Service coupling(s) (monofuel vehicles without limp-home system): 1/**
- 1.2.4.5.13.1. Make(s):
- 1.2.4.5.13.2. Type(s):
- 1.2.4.5.13.3. Description and drawings of installation:
- 1.2.4.5.14. **Connection to LPG system for heating system (allowed at buses only): yes/no 1/**
- 1.2.4.5.14.1. Make(s):

- 1.2.4.5.14.2. Type(s):
- 1.2.4.5.14.3. Description and drawings of installation:
- 1.2.4.5.15. **Fuel rail:** 1/
- 1.2.4.5.15.1. Make(s):
- 1.2.4.5.15.2. Type(s):
- 1.2.4.5.15.3. Description and drawings of installation:
- 1.2.4.5.15.4. Operating pressure(s): 2/ kPa
- 1.2.4.5.16. **Further documentation:**
- 1.2.4.5.16.1. Description of the LPG-equipment and the physical safeguarding of the catalyst at switch-over from petrol to LPG or back
- 1.2.4.5.16.2. System lay-out (electrical connections, vacuum connections compensation hoses, etc.)
- 1.2.4.5.16.3. Drawing of the symbol:
- 1.2.4.5.16.4. Adjustment data:
- 1.2.4.5.16.5. Certificate of the vehicle on petrol, if already granted:
- 1.2.5. **Cooling system:** (liquid/air) 1/
- 1.2.5.1. System description/drawings with regard to the LPG equipment

1/ Strike out what does not apply.
2/ Specify the tolerance.
3/ This value must be rounded off to the nearest tenth of a millimetre.
4/ This value must be calculated with = 3,1416 and rounded off, to the nearest cm³.

Annex 2A

**ARRANGEMENT OF THE LPG EQUIPMENT
TYPE-APPROVAL MARK**

(See paragraph 5.2. of this Regulation)

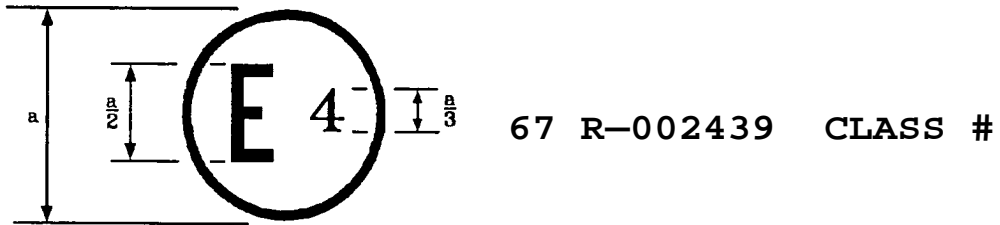

$a \geq 5 \text{ mm}$

The above approval mark affixed to the LPG equipment shows that this equipment has been approved in the Netherlands (E4), pursuant to Regulation No.67 under approval number 002439. The first two digits of the approval number indicate that the approval was granted in accordance with the requirements of Regulation No. 67 in its original form.

Annex 2B

COMMUNICATION

(maximum format: A4 (210 x 297 mm))

issued by: Name of administration:
.....
.....
.....

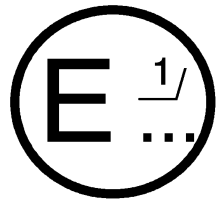

concerning: 2/ APPROVAL GRANTED
APPROVAL EXTENDED
APPROVAL REFUSED
APPROVAL WITHDRAWN
PRODUCTION DEFINITELY DISCONTINUED

of a type of LPG equipment pursuant to Regulation No. 67

Approval No.: Extension No.:

1. LPG equipment considered:
 - Container:
 - Accessories fitted to the container: 2/
 - 80 % stop valve
 - level indicator
 - pressure relief valve (discharge valve)
 - remotely controlled service valve with excess flow valve
 - with/without LPG fuel pump 2/
 - multivalve, including the following accessories:
 - gas-tight housing
 - power supply bushing (pump/actuators) 2/
 - Fuel pump 2/
 - Vaporizer/pressure regulator 2/
 - Shut-off valve 2/
 - Non-return valve 2/

- Gas-tube pressure relief valve 2/
- Service coupling 2/
- Flexible hose 2/
- Remote filling unit 2/
- Gas injection device or injector 2/
- Fuel rail 2/
- Gas dosage unit 2/
- Gas mixing piece 2/
- Electronic control unit 2/
- Pressure/temperature sensor 2/
- LPG filter unit 2/

2. Trade name or mark
3. Manufacturer's name and address
4. If applicable, name and address of manufacturer's representative
5. Submitted for approval on
6. Technical service responsible for conducting approval tests .
7. Date of report issued by that service
8. No. of report issued by that service
9. Approval granted/refused/extended/withdrawn 2/
10. Reason(s) of extension (if applicable)
11. Place
12. Date
13. Signature
14. The documents filed with the application or extension of approval can be obtained upon request.

1/ Distinguishing number of the country which has granted/extended/refused/withdrawn approval (see approval provisions in the Regulation.)

2/ Strike out what does not apply.

Annex 2C

ARRANGEMENT OF APPROVAL MARKS

Model A

(See paragraph 16.2. of this Regulation)

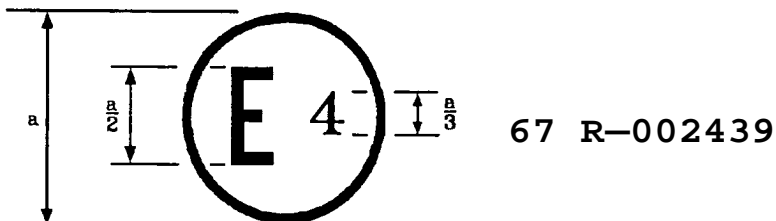

$a \geq 8 \text{ mm}$

The above approval mark affixed to a vehicle shows that the vehicle has, with regard to the installation of specific equipment for the use of LPG for propulsion, been approved in the Netherlands (E4), pursuant to Regulation No. 67 under approval number 002439. The first two digits of the approval number indicate that the approval was granted in accordance with the requirements of Regulation No. 67 in its original form.

Model B

(See paragraph 16.2. of this Regulation)

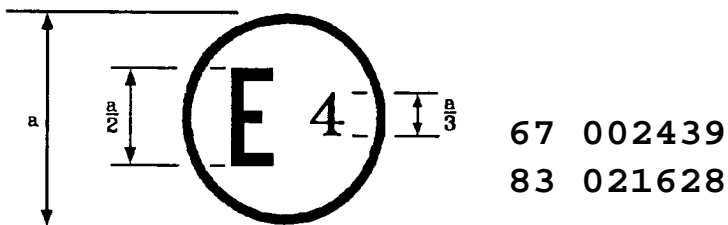

$a \geq 8 \text{ mm}$

The above approval mark affixed to a vehicle shows that the vehicle has, with regard to the installation of specific equipment for the use of LPG for propulsion, been approved in the Netherlands (E4), pursuant to Regulation No.67 under approval number 002439. The first two digits of the approval number indicate that at the date the approval was granted in accordance with the requirements of Regulation No. 67 in its original form and that Regulation No. 83 included the 02 series of amendments.

Annex 2D

COMMUNICATION

(maximum format: A4 (210 x 297 mm))

issued by: Name of administration:
.....
.....
.....

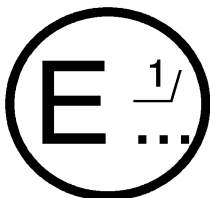

concerning: 2/ APPROVAL GRANTED
APPROVAL EXTENDED
APPROVAL REFUSED
APPROVAL WITHDRAWN
PRODUCTION DEFINITELY DISCONTINUED

of a vehicle type with regard to the installation of LPG systems pursuant to Regulation No.67

Approval No: Extension No:

1. Trade name or mark of vehicle
2. Vehicle type
3. Vehicle category
4. Manufacturer's name and address
5. If applicable, name and address of manufacturer's representative
.
6. Description of the vehicle drawings etc. needs detailing
7. Test results?? needs detailing
8. Submitted for approval on
9. Technical service responsible for conducting approval tests
10. Date of report issued by that service
11. No. of report issued by that service

- 12. Approval granted/refused/extended/withdrawn 2/
- 13. Reason(s) of extension (if applicable)
- 14. Place
- 15. Date
- 16. Signature
- 17. The following documents filed with the application or extension of approval can be obtained upon request.

Drawings, diagrams and scheme plans regarding the components and the installation of the LPG equipment considered to be of importance for the purpose of this Regulation;

Where applicable drawings of the various equipment and their position in the vehicle.

1/ Distinguishing number of the country which has granted/extended/refused/withdrawn approval (see approval provisions in the Regulation.)
2/ Strike out what does not apply.

Annex 3

PROVISIONS REGARDING THE APPROVAL OF LPG CONTAINER ACCESSORIES

1 80 per cent stop valve

1.1. Definition: see paragraph 2.5.1. of this Regulation.

1.2. Component classification (according to figure 1, para. 2): Class 3.

1.3. Classification pressure: 3,000 kPa.

1.4. Design temperatures:

-20°C to 65°C

For temperatures exceeding the above-mentioned values, special tests conditions are applicable.

1.5. General design rules:

Paragraph 6.14.1., Provisions regarding 80 per cent stop valve.

Paragraph 6.14.2., Provisions regarding the electrical insulation.

Paragraph 6.14.3.1., Provisions on valves activated by electrical power.

1.6. Applicable test procedures:

Over pressure test	Annex 15, para. 4
External leakage	Annex 15, para. 5
High temperature	Annex 15, para. 6
Low temperature	Annex 15, para. 7
Seat leakage	Annex 15, para. 8
Endurance	Annex 15, para. 9
Operational test	Annex 15, para. 10
LPG compatibility	Annex 15, para. 11 <u>**</u> /
Corrosion resistance	Annex 15, para. 12
Resistance to dry heat	Annex 15, para. 13
Ozone ageing	Annex 15, para. 14 <u>**</u> /
Creep	Annex 15, para. 15 <u>**</u> /
Temperature cycle	Annex 15, para. 16 <u>**</u> /

*/ only for metallic parts

**/ only for non-metallic parts

2. Level indicator

2.1. Definition: see paragraph 2.5.2. of this Regulation.

2.2. Component classification (according to figure 1, para. 2): Class 1.

2.3. Classification pressure: 3,000 kPa.

2.4. Design temperatures:

-20°C to 65°C

For temperatures exceeding the above-mentioned values, special tests conditions are applicable.

2.5. General design rules:

Paragraph 6.14.11., Provisions regarding the level indicator.

Paragraph 6.14.2., Provisions regarding the electrical insulation.

2.6. Applicable test procedures:

Over pressure test	Annex 15, para. 4
External leakage	Annex 15, para. 5
High temperature	Annex 15, para. 6
Low temperature	Annex 15, para. 7
LPG compatibility	Annex 15, para. 11 <u>**</u> /
Corrosion resistance	Annex 15, para. 12
Resistance to dry heat	Annex 15, para. 13
Ozone ageing	Annex 15, para. 14 <u>**</u> /
Creep	Annex 15, para. 15 <u>**</u> /
Temperature cycle	Annex 15, para. 16 <u>**</u> /

*/ only for metallic parts

**/ only for non-metallic parts

3. Pressure relief valve (discharge valve)

3.1. Definition: see paragraph 2.5.3. of this Regulation.

3.2. Component classification (according to figure 1, para. 2): Class 3.

3.3. Classification pressure: 3,000 kPa.

3.4. Design temperatures:

-20°C to 65°C

For temperatures exceeding the above-mentioned values, special tests conditions are applicable.

3.5. General design rules:

Paragraph 6.14.8., Provisions regarding the pressure relief valve (discharge valve)

3.6. Applicable test procedures:

Over pressure test	Annex 15, para. 4
External leakage	Annex 15, para. 5
High temperature	Annex 15, para. 6
Low temperature	Annex 15, para. 7
Seat leakage	Annex 15, para. 8
Endurance	Annex 15, para. 9 (with 6,000 operation cycles)
Operational test	Annex 15, para. 10
LPG compatibility	Annex 15, para. 11 <u>**</u> /
Corrosion resistance	Annex 15, para. 12
Resistance to dry heat	Annex 15, para. 13
Ozone ageing	Annex 15, para. 14 <u>**</u> /
Creep	Annex 15, para. 15 <u>**</u> /
Temperature cycle	Annex 15, para. 16 <u>**</u> /

*/ only for metallic parts

**/ only for non-metallic parts

4. Remotely controlled service valve with excess flow valve

4.1. Definition: see paragraph 2.6. of this Regulation.

4.2. Component classification (according to figure 1, para. 2): Class 3.

4.3. Classification pressure: 3,000 kPa.

4.4. Design temperatures:

-20°C to 65°C

For temperatures exceeding the above-mentioned values, special tests conditions are applicable.

4.5. General design rules:

Paragraph 6.14.2., Provisions regarding the electrical insulation.

Paragraph 6.14.3.1., Provisions on valves activated by an electrical/external power.

Paragraph 6.14.13., Provisions regarding the remotely controlled service valve with excess flow valve.

4.6. Applicable test procedures:

Over pressure test	Annex 15, para. 4
External leakage	Annex 15, para. 5
High temperature	Annex 15, para. 6
Low temperature	Annex 15, para. 7
Seat leakage	Annex 15, para. 8
Endurance	Annex 15, para. 9
Operational test	Annex 15, para. 10
LPG compatibility	Annex 15, para. 11 <u>**</u> /
Corrosion resistance	Annex 15, para. 12
Resistance to dry heat	Annex 15, para. 13
Ozone ageing	Annex 15, para. 14 <u>**</u> /
Creep	Annex 15, para. 15 <u>**</u> /
Temperature cycle	Annex 15, para. 16 <u>**</u> /

*/ only for metallic parts

**/ only for non-metallic parts

5. Power supply bushing

5.1. Definition: see paragraph 2.5.8. of this Regulation.

5.2. Component classification (according to figure 1, para. 2): Class 1.

5.3. Classification pressure: 3,000 kPa.

5.4. Design temperatures:

-20°C to 65°C

For temperatures exceeding the above-mentioned values, special tests conditions are applicable.

5.5. General design rules:

Paragraph 6.14.2.1., Provisions regarding the electrical insulation.

Paragraph 6.14.2.3., Provisions regarding the power supply bushing.

5.6. Applicable test procedures:

Over pressure test	Annex 15, para. 4
External leakage	Annex 15, para. 5
High temperature	Annex 15, para. 6
Low temperature	Annex 15, para. 7
LPG compatibility	Annex 15, para. 11 <u>**</u> /
Corrosion resistance	Annex 15, para. 12
Resistance to dry heat	Annex 15, para. 13
Ozone ageing	Annex 15, para. 14 <u>**</u> /
Creep	Annex 15, para. 15 <u>**</u> /
Temperature cycle	Annex 15, para. 16 <u>**</u> /

*/ only for metallic parts

**/ only for non-metallic parts

6. Gas-tight housing

6.1. Definition: See paragraph 2.5.7. of this Regulation.

6.2. Component classification (according to figure 1, para. 2):
Not applicable.

6.3. Classification pressure: Not applicable.

6.4. Design temperatures:
-20°C to 65°C
For temperatures exceeding the above-mentioned values, special tests conditions are applicable.

6.5. General design rules:
Paragraph 6.14.12., Provisions regarding the gas-tight housing.

6.6. Applicable test procedures:

Over pressure test	Annex 15, para. 4 (at 50 kPa)
External leakage	Annex 15, para. 5 (at 10 kPa)
High temperature	Annex 15, para. 6
Low temperature	Annex 15, para. 7

*/ only for metallic parts

**/ only for non-metallic parts

Annex 4

PROVISIONS REGARDING THE APPROVAL OF THE FUEL PUMP

- 1 Definition: see paragraph 2.7. of this Regulation.
2. Component classification (according to figure 1, para. 2): Class 1.
3. Classification pressure: 3,000 kPa.
4. Design temperatures:

-20°C to 65°C, when the fuel pump is mounted inside the container.
-20°C to 120°C, when the fuel pump is mounted outside the container.
For temperatures exceeding the above-mentioned values, special tests conditions are applicable.
5. General design rules:

Paragraph 6.14.2., Provisions regarding the electrical insulation.
Paragraph 6.14.2., Provisions regarding the insulation class.
Paragraph 6.14.3.2., Provisions when the power is switched off.
Paragraph 6.14.6.1., Provisions to prevent pressure build-up.
6. Applicable test procedures:
 - 6.1. Fuel pump mounted inside the container:

LPG compatibility Annex 15, para. 11 **/
 - 6.2. Fuel pump mounted outside the container:

Over pressure test Annex 15, para. 4
External leakage Annex 15, para. 5
High temperature Annex 15, para. 6
Low temperature Annex 15, para. 7
LPG compatibility Annex 15, para. 11 **/
Corrosion resistance Annex 15, para. 12
Resistance to dry heat Annex 15, para. 13
Ozone ageing Annex 15, para. 14 **/
Creep Annex 15, para. 15 **/
Temperature cycle Annex 15, para. 16 **/

*/ only for metallic parts

**/ only for non-metallic parts

Annex 5

PROVISIONS REGARDING THE APPROVAL OF THE LPG FILTER UNIT

1. Definition: see paragraph 2.18. of this Regulation.
2. Component classification (according to figure 1, para. 2):

Filter units can be Class 1, 2 or 2A.
3. Classification pressure:

Components of Class 1: 3,000 kPa.
Components of Class 2: 450 kPa.
Components of Class 2A: 120 kPa.
4. Design temperatures:

-20°C to 120°C
For temperatures exceeding the above-mentioned values, special tests conditions are applicable.
5. General design rules: (not used)
6. Applicable test procedures:
 - 6.1. For parts of Class 1:

Over pressure test	Annex 15, para. 4
External leakage	Annex 15, para. 5
High temperature	Annex 15, para. 6
Low temperature	Annex 15, para. 7
LPG compatibility	Annex 15, para. 11 <u>**</u> /
Corrosion resistance	Annex 15, para. 12
Resistance to dry heat	Annex 15, para. 13
Ozone ageing	Annex 15, para. 14 <u>**</u> /
Creep	Annex 15, para. 15 <u>**</u> /
Temperature cycle	Annex 15, para. 16 <u>**</u> /
 - 6.2. For parts of Class 2 and/or 2A:

Over pressure test	Annex 15, para. 4
External leakage	Annex 15, para. 5
High temperature	Annex 15, para. 6
Low temperature	Annex 15, para. 7
LPG compatibility	Annex 15, para. 11 <u>**</u> /
Corrosion resistance	Annex 15, para. 12

*/ only for metallic parts

**/ only for non-metallic parts

Annex 6

PROVISIONS REGARDING THE APPROVAL OF THE PRESSURE REGULATOR AND THE VAPORIZER

1. Definition:

Vaporizer: see paragraph 2.9. of this Regulation.

Pressure regulator: see paragraph 2.10 of this Regulation.

2. Component classification (according to figure 1, para. 2):

Class 1: for the part which is in contact with the pressure of the containers.

Class 2: for the part which is in contact with the regulated pressure and with a maximum regulated pressure during operation of 450 kPa.

Class 2A: for the part which is in contact with the regulated pressure and with a maximum regulated pressure during operation of 120 kPa.

3. Classification pressure:

Parts of Class 1: 3,000 kPa.

Parts of Class 2: 450 kPa.

Parts of Class 2A: 120 kPa.

4. Design temperatures:

-20°C to 120°C

For temperatures exceeding the above-mentioned values, special tests conditions are applicable.

5. General design rules:

Paragraph 6.14.2., Provisions regarding the electrical insulation.

Paragraph 6.14.3.1., Provisions on valves activated by external power.

Paragraph 6.14.4., Heat exchange medium (compatibility and pressure requirements).

Paragraph 6.14.5., Overpressure bypass security.

Paragraph 6.14.6.2., Gas flow prevention.

6. Applicable test procedures:

6.1. For parts of Class 1:

Over pressure test	Annex 15, para. 4
External leakage	Annex 15, para. 5
High temperature	Annex 15, para. 6
Low temperature	Annex 15, para. 7
Seat leakage	Annex 15, para. 8
Endurance	Annex 15, para. 9
LPG compatibility	Annex 15, para. 11 <u>**</u> /

Corrosion resistance	Annex 15, para. 12 <u>*/</u>
Resistance to dry heat	Annex 15, para. 13
Ozone ageing	Annex 15, para. 14 <u>**/</u>
Creep	Annex 15, para. 15 <u>**/</u>
Temperature cycle	Annex 15, para. 16 <u>**/</u>

6.2. For parts of Class 2 and/or 2A:

Over pressure test	Annex 15, para. 4
External leakage	Annex 15, para. 5
High temperature	Annex 15, para. 6
Low temperature	Annex 15, para. 7
LPG compatibility	Annex 15, para. 11 <u>**/</u>
Corrosion resistance	Annex 15, para. 12

Remarks:

The shut-off valve can be integrated in the vaporizer, regulator, in this case annex 7 is also applicable.

The parts of the pressure regulator/vaporizer (Class 1, 2 or 2A) shall be leakproof with the outlet(s) of that part closed off.

For the overpressure test all the outlets including those of the coolant compartment shall be closed off.

*/ only for metallic parts

**/ only for non-metallic parts

Annex 7

**PROVISIONS REGARDING THE APPROVAL OF THE SHUT-OFF VALVE, THE NON-RETURN VALVE,
THE GAS-TUBE PRESSURE RELIEF VALVE AND THE SERVICE COUPLING**

1. Provisions regarding the approval of the shut-off valve

1.1. Definition: see paragraph 2.11. of this Regulation.

1.2. Component classification (according to figure 1, para. 2): Class 3.

1.3. Classification pressure: 3,000 kPa.

1.4. Design temperatures:

-20°C to 120°C

For temperatures exceeding the above-mentioned values, special tests conditions are applicable.

1.5. General design rules:

Paragraph 6.14.2., Provisions regarding the electrical insulation.
Paragraph 6.14.3.1., Provisions on valves activated by electrical power.

1.6. Applicable test procedures:

Over pressure test	Annex 15, para. 4
External leakage	Annex 15, para. 5
High temperature	Annex 15, para. 6
Low temperature	Annex 15, para. 7
Seat leakage	Annex 15, para. 8
Endurance	Annex 15, para. 9
LPG compatibility	Annex 15, para. 11 <u>**/</u>
Corrosion resistance	Annex 15, para. 12 <u>*/</u>
Resistance to dry heat	Annex 15, para. 13
Ozone ageing	Annex 15, para. 14 <u>**/</u>
Creep	Annex 15, para. 15 <u>**/</u>
Temperature cycle	Annex 15, para. 16 <u>**/</u>

*/ only for metallic parts

**/ only for non-metallic parts

2. Provisions regarding the approval of the non-return valve

2.1. Definition: see paragraph 2.12. of this Regulation.

2.2. Component classification (according to figure 1, para. 2): Class 1.

2.3. Classification pressure: 3,000 kPa.

2.4. Design temperatures:

-20°C to 120°C

For temperatures exceeding the above-mentioned values, special tests conditions are applicable.

2.5. General design rules:

Paragraph 6.14.2., Provisions regarding the electrical insulation.
Paragraph 6.14.3.1., Provisions on valves activated by electrical power.

2.6. Applicable test procedures:

Over pressure test	Annex 15, para. 4
External leakage	Annex 15, para. 5
High temperature	Annex 15, para. 6
Low temperature	Annex 15, para. 7
Seat leakage	Annex 15, para. 8
Endurance	Annex 15, para. 9
LPG compatibility	Annex 15, para. 11 <u>**</u> /
Corrosion resistance	Annex 15, para. 12 <u>*</u> /
Resistance to dry heat	Annex 15, para. 13
Ozone ageing	Annex 15, para. 14 <u>**</u> /
Creep	Annex 15, para. 15 <u>**</u> /
Temperature cycle	Annex 15, para. 16 <u>**</u> /

*/ only for metallic parts

**/ only for non-metallic parts

3. Provisions regarding the approval of the gas-tube relief valve

3.1. Definition: see paragraph 2.13. of this Regulation.

3.2. Component classification (according to figure 1, para. 2): Class 3.

3.3. Classification pressure: 3,000 kPa.

3.4. Design temperatures:

-20°C to 120°C

For temperatures exceeding the above-mentioned values, special tests conditions are applicable.

3.5. General design rules:

Paragraph 6.14.2., Provisions regarding the electrical insulation.

Paragraph 6.14.3.1., Provisions on valves activated by electrical power.

Paragraph 6.14.7., Provisions regarding the gas-tube pressure relief valve.

3.6. Applicable test procedures:

Over pressure test	Annex 15, para. 4
External leakage	Annex 15, para. 5
High temperature	Annex 15, para. 6
Low temperature	Annex 15, para. 7
Seat leakage	Annex 15, para. 8
Endurance	Annex 15, para. 9 (with 6,000 operation cycles)
LPG compatibility	Annex 15, para. 11 <u>**</u> /
Corrosion resistance	Annex 15, para. 12 <u>*</u> /
Resistance to dry heat	Annex 15, para. 13
Ozone ageing	Annex 15, para. 14 <u>**</u> /
Creep	Annex 15, para. 15 <u>**</u> /
Temperature cycle	Annex 15, para. 16 <u>**</u> /

*/ only for metallic parts

**/ only for non-metallic parts

4. Provisions regarding the approval of the service coupling

4.1. Definition: see paragraph 2.21. of this Regulation.

4.2. Component classification (according to figure 1, para. 2): Class 1.

4.3. Classification pressure: 3,000 kPa.

4.4. Design temperatures:

-20°C to 120°C

For temperatures exceeding the above-mentioned values, special tests conditions are applicable.

4.5. General design rules:

Paragraph 6.14.2., Provisions regarding the electrical insulation.
Paragraph 6.14.3.1., Provisions on valves activated by electrical power.

4.6. Applicable test procedures:

Over pressure test	Annex 15, para. 4
External leakage	Annex 15, para. 5
High temperature	Annex 15, para. 6
Low temperature	Annex 15, para. 7
Seat leakage	Annex 15, para. 8
Endurance	Annex 15, para. 9 (with 6,000 operation cycles)
LPG compatibility	Annex 15, para. 11 <u>**</u> /
Corrosion resistance	Annex 15, para. 12 <u>*</u> /
Resistance to dry heat	Annex 15, para. 13
Ozone ageing	Annex 15, para. 14 <u>**</u> /
Creep	Annex 15, para. 15 <u>**</u> /
Temperature cycle	Annex 15, para. 16 <u>**</u> /

*/ only for metallic parts

**/ only for non-metallic parts

Annex 8

PROVISIONS REGARDING THE APPROVAL OF FLEXIBLE HOSES WITH COUPLINGS

Scope

The purpose of this annex is to determine the provisions regarding the approval of flexible hoses for use with LPG, having an inside diameter up to 20 mm.

This annex covers three types of flexible hoses:

- (i) High pressure rubber hoses (Class 1, e.g. Filling hose)
- (ii) Low pressure rubber hoses (Class 2)
- (iii) High pressure synthetic hoses (Class 1)

1. HIGH PRESSURE RUBBER HOSES, CLASS 1 CLASSIFICATION, FILLING HOSE

1.1. General specifications

- 1.1.1. The hose shall be so designed as to withstand a maximum operating pressure of 3,000 kPa.
- 1.1.2. The hose shall be so designed as to withstand temperatures between -25°C and +80°C. For operating temperatures exceeding the above-mentioned values, the test temperatures must be adapted.
- 1.1.3. The inside diameter shall be in compliance with table 1 of ISO standard 1307.

1.2. Hose construction

- 1.2.1. The hose must embody a smooth-bore tube and a cover of suitable synthetic material, reinforced with one or more interlayer(s).
- 1.2.2. The reinforcing interlayer(s) has (have) to be protected by a cover against corrosion.

If for the reinforcing interlayer(s) corrosion-resistant-material is used (i.e. stainless-steel) a cover is not required.
- 1.2.3. The lining and the cover must be smooth and free from pores, holes and strange elements.
An intentionally provided puncture in the cover shall not be considered as an imperfection.
- 1.2.4. The cover has to be intentionally perforated to avoid the forming of bubbles.
- 1.2.5. When the cover is punctured and the interlayer is made of a non-corrosion-resistant material, the interlayer has to be protected against corrosion.

1.3. Specifications and tests for the lining

1.3.1. Tensile strength and elongation

1.3.1.1. Tensile strength and elongation at break according to ISO 37.
Tensile strength not less than 10 MPa and elongation at break not less than 250 %.

1.3.1.2. Resistance to n-pentane according to ISO 1817 with the following conditions:

- (i) medium: n-pentane
- (ii) temperature: 23°C (tolerance acc.to ISO 1817)
- (iii) immersion period: 72 hours

Requirements:

- (i) maximum change in volume 20 %
- (ii) maximum change in tensile strength 25 %
- (iii) maximum change in elongation at break 30 %

After storage in air with a temperature of 40°C for a period of 48 hours the mass compared to the original value may not decrease more than 5 %.

1.3.1.3. Resistance to ageing according to ISO 188 with the following conditions:

- (i) temperature: 70°C (test temperature = maximum operating temperature - 10°C)
- (ii) exposure period: 168 hours

Requirements:

- (i) maximum change in tensile strength 25 %
- (ii) maximum change in elongation at break -30 % and +10 %

1.4. Specifications and test-method for the cover

1.4.1.1. Tensile strength and elongation at break according to ISO 37.
Tensile strength not less than 10 MPa and elongation at break not less than 250 %.

1.4.1.2. Resistance to n-hexane according to ISO 1817 with the following conditions:

- (i) medium: n-hexane
- (ii) temperature: 23 °C (tolerance acc.to ISO 1817)
- (iii) immersion period: 72 hours

Requirements:

- (i) maximum change in volume 30 %
- (ii) maximum change in tensile strength 35 %
- (iii) maximum change in elongation at break 35 %

1.4.1.3. Resistance to ageing according to ISO 188 with the following conditions:

- (i) temperature: 70°C (test temperature = maximum operating temperature - 10°C)
- (ii) exposure period: 336 hours

Requirements:

- (i) maximum change in tensile strength 25 %
- (ii) maximum change in elongation at break -30 % and +10 %

1.4.2. **Resistance to Ozone**

1.4.2.1. The test has to be performed in compliance with ISO standard 1431/1.

1.4.2.2. The test-pieces, which have to be stretched to an elongation of 20 % shall have to be exposed to air of 40°C with an ozone-concentration of 50 parts per hundred million during 120 hours.

1.4.2.3. No cracking of the test pieces is allowed.

1.5. **Specifications for uncoupled hose**

1.5.1. **Gas-tightness (permeability)**

1.5.1.1. A hose at a free length of 1 m has to be connected to a container filled with liquid propane, having a temperature of $23^{\circ} \pm 2^{\circ}\text{C}$.

1.5.1.2. The test has to be carried out in compliance with the method described in ISO-standard 4080.

1.5.1.3. The leakage through the wall of the hose shall not exceed 95 cm³ of vapour per metre of hose per 24 h.

1.5.2. **Resistance at low temperature**

1.5.2.1. The test has to be carried out in compliance with the method described in ISO-standard 4672-1978 method B.

1.5.2.2. Test-temperature: $-25^{\circ} \pm 3^{\circ}\text{C}$.

1.5.2.3. No cracking or rupture is allowed.

1.5.3. (Not used)

1.5.3.1. (Not used)

1.5.3.2. (Not used)

1.5.4. **Bending test**

1.5.4.1. An empty hose, at a length of approximately 3.5 m must be able to withstand 3,000 times the hereafter prescribed alternating-bending-test without breaking. After the test the hose must be capable of withstanding the test-pressure as mentioned in paragraph 1.5.5.2.

1.5.4.2.

Inside diameter in mm	Bending radius in mm	Distance between centres Vertical-mm-Horizontal	
up to 13	102	241	102
13 to 16	153	356	153
from 16 to 20	178	419	178

1.5.4.3. The testing-machine shall consist of a steel frame, provided with two wooden wheels, with a rim-width of c.a. 130 mm.

The circumference of the wheels must be grooved for the guidance of the hose.

The radius of the wheels, measured to the bottom of the groove, must be as indicated in paragraph 1.5.4.2.

The longitudinal median planes of both wheels must be in the same vertical plane and the distance between the wheel-centres must be in accordance with paragraph 1.5.4.2.

Each wheel must be able to rotate freely round its pivot-centre.

A propulsion-mechanism pulls the hose over the wheels at a speed of four complete motions per minute.

1.5.4.4. The hose shall be S-shape-like installed over the wheels.

The end, that runs over the upper wheel shall be furnished with a sufficient mass as to achieve a complete snugling of the hose against the wheels. The part that runs over the lower wheel is attached to the propulsion-mechanism.

The mechanism must be so adjusted, that the hose travels a total distance of 1.2 m in both directions.

1.5.5. Hydraulic-test-pressure and appointment of the minimum burst-pressure

- 1.5.5.1. The test has to be carried out in compliance with the method described in ISO-standard 1402.
- 1.5.5.2. The test-pressure of 6,750 kPa shall be applied during 10 minutes, without any leakage.
- 1.5.5.3. The burst pressure shall not be less than 10,000 kPa.

1.6. Couplings

- 1.6.1. The couplings shall be made from steel or brass and the surface must be corrosion-resistant.
- 1.6.2. The couplings must be of the crimp-fitting type.
 - 1.6.2.1. The swivel-nut must be provided with U.N.F.-thread.
 - 1.6.2.2. The sealing-cone must be of the type with a half vertical angle of 45°.

1.7. Assembly of hose and couplings

- 1.7.1. The construction of the couplings must be such, that it is not necessary to peel the cover unless the reinforcement of the hose consists of corrosion-resistant material.
- 1.7.2. The hose assembly has to be subjected to an impulse test in compliance with ISO-standard 1436.
 - 1.7.2.1. The test has to be completed with circulating oil having a temperature of 93°C, and a minimum pressure of 3,000 kPa.
 - 1.7.2.2. The hose has to be subjected to 150,000 impulses.
 - 1.7.2.3. After the impulse-test the hose has to withstand the test-pressure as mentioned in paragraph 1.5.5.2.

1.7.3. Gas-tightness

- 1.7.3.1. The hose assembly (hose with couplings) has to withstand during five minutes a gas pressure of 3,000 kPa without any leakage.

1.8. Markings

- 1.8.1. Every hose must bear, at intervals of not greater than 0.5 m, the following clearly legible and indelible identification markings consisting of characters, figures or symbols.
 - 1.8.1.1. The trade name or mark of the manufacturer.

- 1.8.1.2. The year and month of fabrication.
- 1.8.1.3. The size and type-marking.
- 1.8.1.4. The identification-marking "L.P.G. Class 1".
- 1.8.2. Every coupling shall bear the trade name or mark of the assembling manufacturer.

2. LOW PRESSURE RUBBER HOSES, CLASS 2 CLASSIFICATION

2.1. General specifications

- 2.1.1. The hose shall be so designed as to withstand a maximum operating pressure of 450 kPa.
- 2.1.2. The hose shall be so designed as to withstand temperatures between -25°C and +125°C. For operating temperatures exceeding the above-mentioned values, the test temperatures must be adapted.

2.2. Hose construction

- 2.2.1. The hose must embody a smooth-bore tube and a cover of suitable synthetic material, reinforced with one or more interlayer(s).
- 2.2.2. The reinforcing interlayer(s) has (have) to be protected by a cover against corrosion.

If for the reinforcing interlayer(s) corrosion-resistant-material is used (i.e. stainless-steel) a cover is not required.
- 2.2.3. The lining and the cover must be smooth and free from pores, holes and strange elements.
An intentionally provided puncture in the cover shall not be considered as an imperfection.

2.3. Specifications and tests for the lining

2.3.1. Tensile strength and elongation

- 2.3.1.1. Tensile strength and elongation at break according to ISO 37.
Tensile strength not less than 10 MPa and elongation at break not less than 250 %.
- 2.3.1.2. Resistance to n-pentane according to ISO 1817 with the following conditions:
 - (i) medium: n-pentane
 - (ii) temperature: 23°C (tolerance acc. to ISO 1817)
 - (iii) immersion period: 72 hours

Requirements:

- (i) maximum change in volume 20 %
- (ii) maximum change in tensile strength 25 %
- (iii) maximum change in elongation at break 30 %

After storage in air with a temperature of 40°C for a period of 48 hours the mass compared to the original value may not decrease more than 5 %.

2.3.1.3. Resistance to ageing according to ISO 188 with the following conditions:

- (i) temperature: 115°C (test temperature = maximum operating temperature - 10°C)
- (ii) exposure period: 168 hours

Requirements:

- (i) maximum change in tensile strength 25 %
- (ii) maximum change in elongation at break -30 % and +10 %

2.4. Specifications and test-method for the cover

2.4.1.1. Tensile strength and elongation at break according to ISO 37. Tensile strength not less than 10 MPa and elongation at break not less than 250 %.

2.4.1.2. Resistance to n-hexane according to ISO 1817 with the following conditions:

- (i) medium: n-hexane
- (ii) temperature: 23°C (tolerance acc. to ISO 1817)
- (iii) immersion period: 72 hours

Requirements:

- (i) maximum change in volume 30 %
- (ii) maximum change in tensile strength 35 %
- (iii) maximum change in elongation at break 35 %

2.4.1.3. Resistance to ageing according to ISO 188 with the following conditions:

- (i) temperature: 115 °C (test temperature = maximum operating temperature - 10°C)
- (ii) exposure period: 336 hours

Requirements:

- (i) maximum change in tensile strength 25 %
- (ii) maximum change in elongation at break -30 % and +10 %

2.4.2. Resistance to Ozone

2.4.2.1. The test has to be performed in compliance with ISO standard 1431/1.

2.4.2.2. The test-pieces, which have to be stretched to an elongation of 20 % shall have to be exposed to air of 40°C with an ozone-concentration of 50 parts per hundred million during 120 hours.

2.4.2.3. No cracking of the test pieces is allowed.

2.5. Specifications for uncoupled hose

2.5.1. Gas-tightness (permeability)

2.5.1.1. A hose at a free length of 1 m has to be connected to a container filled with liquid propane, having a temperature of 23° ± 2°C.

2.5.1.2. The test has to be carried out in compliance with the method described in ISO-standard 4080.

2.5.1.3. The leakage through the wall of the hose shall not exceed 95 cm³ of vapour per metre of hose per 24 h.

2.5.2. Resistance at low temperature

2.5.2.1. The test has to be carried out in compliance with the method described in ISO-standard 4672-1978 method B.

2.5.2.2. Test-temperature: -25° ± 3°C.

2.5.2.3. No cracking or rupture is allowed.

2.5.3. Bending test

2.5.3.1. An empty hose, at a length of approximately 3.5 m must be able to withstand 3,000 times the hereafter prescribed alternating-bending-test without breaking. After the test the hose must be capable of withstanding the test-pressure as mentioned in paragraph 2.5.4.2.

2.5.3.2.

Inside diameter in mm	Bending radius in mm	Distance between centres Vertical-mm-Horizontal	
up to 13	102	241	102
13 to 16	153	356	153
from 16 to 20	178	419	178

2.5.3.3. The testing-machine shall consist of a steel frame, provided with two wooden wheels, with a rim-width of c.a. 130 mm.

The circumference of the wheels must be grooved for the guidance of the hose.

The radius of the wheels, measured to the bottom of the groove, must be as indicated in paragraph 2.5.3.2.

The longitudinal median planes of both wheels must be in the same vertical plane and the distance between the wheel-centres must be in accordance with paragraph 2.5.3.2.

Each wheel must be able to rotate freely round its pivot-centre.

A propulsion-mechanism pulls the hose over the wheels at a speed of four complete motions per minute.

2.5.3.4. The hose shall be S-shape-like installed over the wheels.

The end, that runs over the upper wheel shall be furnished with a sufficient mass as to achieve a complete snuggling of the hose against the wheels. The part that runs over the lower wheel is attached to the propulsion-mechanism.

The mechanism must be so adjusted, that the hose travels a total distance of 1.2 m in both directions.

2.5.4. **Hydraulic-test-pressure and appointment of the minimum burst-pressure**

2.5.4.1. The test has to be carried out in compliance with the method described in ISO-standard 1402.

2.5.4.2. The test-pressure of 1,015 kPa shall be applied during 10 minutes, without any leakage.

2.5.4.3. The burst pressure shall not be less than 1,800 kPa.

2.6. Couplings

2.6.1. The couplings shall be made from a non-corrosive material.

2.6.2. The coupling burst pressure in mounted position shall never be less than the tube or hose burst pressure.
The coupling leakage pressure in mounted position shall never be less than the tube or hose leakage pressure.

2.6.3. The couplings must be of the crimp-fitting type.

2.7. Assembly of hose and couplings

2.7.1. The construction of the couplings must be such, that it is not necessary to peel the cover unless the reinforcement of the hose consists of corrosion-resistant material.

- 2.7.2. The hose assembly has to be subjected to an impulse test in compliance with ISO-standard 1436.
- 2.7.2.1. The test has to be completed with circulating oil having a temperature of 93°C, and a minimum pressure of 1,015 kPa.
- 2.7.2.2. The hose has to be subjected to 150,000 impulses.
- 2.7.2.3. After the impulse-test the hose has to withstand the test-pressure as mentioned in paragraph 2.5.4.2.
- 2.7.3. **Gas-tightness**
- 2.7.3.1. The hose assembly (hose with couplings) has to withstand during five minutes a gas pressure of 1,250 kPa without any leakage.
- 2.8. **Markings**
- 2.8.1. Every hose must bear, at intervals of not greater than 0.5 m, the following clearly legible and indelible identification markings consisting of characters, figures or symbols.
- 2.8.1.1. The trade name or mark of the manufacturer.
- 2.8.1.2. The year and month of fabrication.
- 2.8.1.3. The size and type-marking.
- 2.8.1.4. The identification-marking "L.P.G. Class 2".
- 2.8.2. Every coupling shall bear the trade name or mark of the assembling manufacturer.
- 3. **HIGH PRESSURE SYNTHETIC HOSES, CLASS 1 CLASSIFICATION**
- 3.1. **General specifications**
- 3.1.1. The purpose chapter to determine the provisions regarding the approval of synthetic flexible hoses for use with LPG, having an inside diameter up to 10 mm.
- 3.1.2. The hose shall be so designed as to withstand a maximum operating pressure of 3,000 kPa.
- 3.1.3. The hose shall be so designed as to withstand temperatures between -25°C and +120°C. For operating temperatures exceeding the above-mentioned values, the test temperatures must be adapted.
- 3.1.4. The inside diameter shall be in compliance with table 1 of ISO standard 1307.

3.2. Hose construction

3.2.1. The synthetic hose must embody a thermoplastic tube and a cover of suitable thermoplastic material, oil and weatherproof, reinforced with one or more synthetic interlayer(s).

3.2.2. The lining and the cover must be free from pores, holes and strange elements.
An intentionally provided puncture in the cover shall not be considered as an imperfection.

3.3. Specifications and tests for the lining

3.3.1. Tensile strength and elongation

3.3.1.1. Tensile strength and elongation at break according to ISO 37.
Tensile strength not less than 20 MPa and elongation at break not less than 200 %.

3.3.1.2. Resistance to n-pentane according to ISO 1817 with the following conditions:
(i) medium: n-pentane
(ii) temperature: 23°C (tolerance acc. to ISO 1817)
(iii) immersion period: 72 hours

Requirements:

- (i) maximum change in volume 20 %
- (ii) maximum change in tensile strength 25 %
- (iii) maximum change in elongation at break 30 %

After storage in air with a temperature of 40°C for a period of 48 hours the mass compared to the original value may not decrease more than 5 %.

3.3.1.3. Resistance to ageing according to ISO 188 with the following conditions:
(i) temperature: 120°C (tolerance according to ISO 188)
(ii) exposure period: 168 hours

Requirements:

- (i) maximum change in tensile strength 35 %
- (ii) maximum change in elongation at break -30 % and +10 %

3.4. Specifications and test-method for the cover

3.4.1.1. Tensile strength and elongation at break according to ISO 37.
Tensile strength not less than 20 MPa and elongation at break not less than 250 %.

3.4.1.2. Resistance to n-hexane according to ISO 1817 with the following conditions:

- (i) medium: n-hexane
- (ii) temperature: 23°C (tolerance acc. to ISO 1817)
- (iii) immersion period: 72 hours

Requirements:

- (i) maximum change in volume 30 %
- (ii) maximum change in tensile strength 35 %
- (iii) maximum change in elongation at break 35 %

3.4.1.3. Resistance to ageing according to ISO 188 with the following conditions:

- (i) temperature: 70 °C (test temperature = maximum operating temperature - 10°C)
- (i) exposure period: 336 hours

Requirements:

- (i) maximum change in tensile strength 25 %
- (ii) maximum change in elongation at break -30 % and +10 %

3.4.2. **Resistance to Ozone**

3.4.2.1. The test has to be performed in compliance with ISO standard 1431/1.

3.4.2.2. The test-pieces, which have to be stretched to an elongation of 20 % shall have to be exposed to air of 40°C and a relative humidity of 50 % ± 10 % with an ozone-concentration of 50 parts per hundred million during 120 hours.

3.4.2.3. No cracking of the test pieces is allowed.

3.5. **Specifications for uncoupled hose**

3.5.1. **Gas-tightness (permeability)**

3.5.1.1. A hose at a free length of 1 m has to be connected to a container filled with liquid propane, having a temperature of 23° ± 2°C.

3.5.1.2. The test has to be carried out in compliance with the method described in ISO-standard 4080.

3.5.1.3. The leakage through the wall of the hose shall not exceed 95 cm³ of vapour per metre of hose per 24 h.

3.5.2. **Resistance at low temperature**

3.5.2.1. The test has to be carried out in compliance with the method described in ISO-standard 4672 method B.

3.5.2.2. Test-temperature: -25° ± 3°C.

3.5.2.3. No cracking or rupture is allowed.

3.6.2. **Resistance at high temperature**

3.6.2.1. A piece of hose, pressurized at 3,000 kPa, with a minimal length of 0.5 m must be put in an oven at a temperature of $120^{\circ}\text{C} \pm 2^{\circ}\text{C}$ during 24 hours.

3.6.2.2. No leakage is allowed.

3.6.2.3. After the test the hose shall withstand the test pressure of 6,750 kPa during 10 minutes. No leakage is allowed.

3.6.3. (Not used)

3.6.3.1. (Not used)

3.6.3.2. (Not used)

3.6.4. **Bending test**

3.6.4.1. An empty hose, at a length of approximately 3.5 m must be able to withstand 3,000 times the hereafter prescribed alternating-bending-test without breaking. After the test the hose must be capable of withstanding the test-pressure as mentioned in paragraph 3.5.5.2.

3.6.4.2. The testing-machine shall consist of a steel frame, provided with two wooden wheels, with a rim-width of approx. 130 mm.

The circumference of the wheels must be grooved for the guidance of the hose.

The radius of the wheels, measured to the bottom of the groove, must be 102 mm.

The longitudinal median planes of both wheels must be in the same vertical plane. The distance between the wheel-centres must be vertical 241 mm and horizontal 102 mm.

Each wheel must be able to rotate freely round its pivot-centre.

A propulsion-mechanism pulls the hose over the wheels at a speed of four complete motions per minute.

3.6.4.4. The hose shall be S-shape-like installed over the wheels.

The end, that runs over the upper wheel, shall be furnished with a sufficient mass as to achieve a complete snuggling of the hose against the wheels. The part that runs over the lower wheel is attached to the propulsion-mechanism.

The mechanism must be so adjusted, that the hose travels a total distance of 1.2 m in both directions.

3.6.5. Hydraulic-test-pressure and appointment of the minimum burst-pressure

- 3.6.5.1. The test has to be carried out in compliance with the method described in ISO-standard 1402.
- 3.6.5.2. The test-pressure of 6,750 kPa shall be applied during 10 minutes, without any leakage.
- 3.6.5.3. The burst pressure shall not be less than 10,000 kPa.

3.7. Couplings

- 3.7.1. The couplings shall be made from steel or brass and the surface must be corrosion-resistant.
- 3.7.2. The couplings must be of the crimp-fitting type and made up of a hose-coupling or banjo bolt. The sealing shall be resistant to LPG and comply with paragraph 3.3.1.2.
- 3.7.3. The banjo bolt shall comply with DIN 7643.

3.8. Assembly of hose and couplings

- 3.8.1. The hose assembly has to be subjected to an impulse test in compliance with ISO-standard 1436.
 - 3.8.1.1. The test has to be completed with circulating oil having a temperature of 93°C, and a minimum pressure of 3,000 kPa.
 - 3.8.1.2. The hose has to be subjected to 150,000 impulses.
 - 3.8.1.3. After the impulse-test the hose has to withstand the test-pressure as mentioned in paragraph 3.5.5.2.

3.8.2. Gas-tightness

- 3.8.2.1. The hose assembly (hose with couplings) has to withstand during five minutes a gas pressure of 3,000 kPa without any leakage.

3.9. Markings

- 3.9.1. Every hose must bear, at intervals of not greater than 0.5 m, the following clearly legible and indelible identification markings consisting of characters, figures or symbols.
 - 3.9.1.1. The trade name or mark of the manufacturer.
 - 3.9.1.2. The year and month of fabrication.

- 3.9.1.3. The size and type-marking.
 - 3.9.1.4. The identification-marking "L.P.G. Class 1".
 - 3.9.2. Every coupling shall bear the trade name or mark of the assembling manufacturer.
-

Annex 9

PROVISIONS REGARDING THE APPROVAL OF THE FILLING UNIT

1. Definition: see paragraph 2.20. of this Regulation.
2. Component classification (according to figure 1, para. 2):

Filling unit: Class 3
Non-return valve: Class 3
3. Classification pressure: 3,000 kPa.
4. Design temperatures:

-20°C to 65°C
For temperatures exceeding the above-mentioned values, special tests conditions are applicable.
5. General design rules:

Paragraph 6.14.2., Provisions regarding the electrical insulation.
Paragraph 6.14.9., Provisions regarding non-return valve.
Paragraph 6.14.10., Provisions regarding the filling unit.
6. Applicable test procedures:

Over pressure test	Annex 15, para. 4
External leakage	Annex 15, para. 5
High temperature	Annex 15, para. 6
Low temperature	Annex 15, para. 7
Seat leakage test	Annex 15, para. 8
Endurance	Annex 15, para. 9 (with 6,000 operation cycles)
LPG compatibility	Annex 15, para. 11 <u>**</u> /
Corrosion resistance	Annex 15, para. 12
Creep	Annex 15, para. 15 <u>**</u> /
Temperature cycle	Annex 15, para. 16 <u>**</u> /

*/ only for metallic parts

**/ only for non-metallic parts

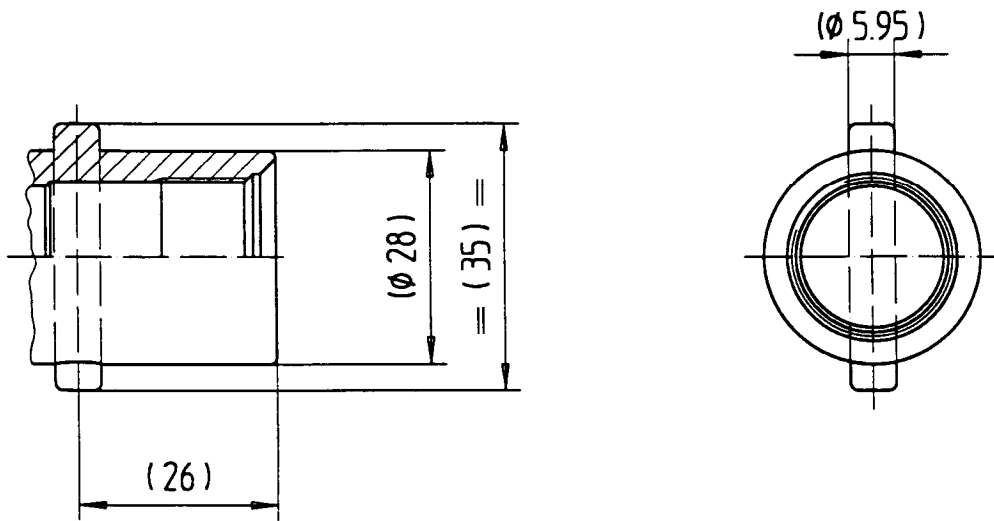

Figure 1

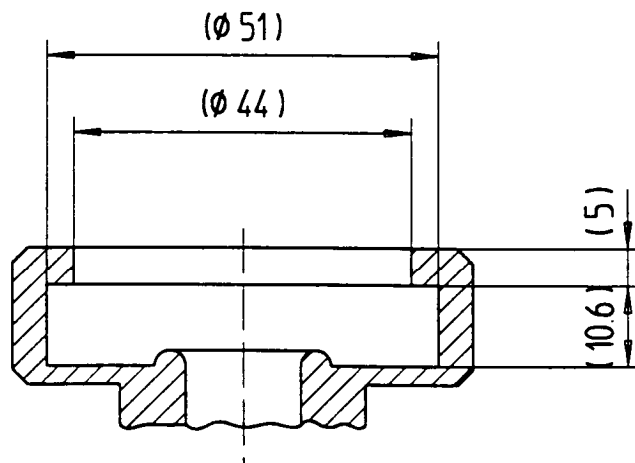

Figure 2

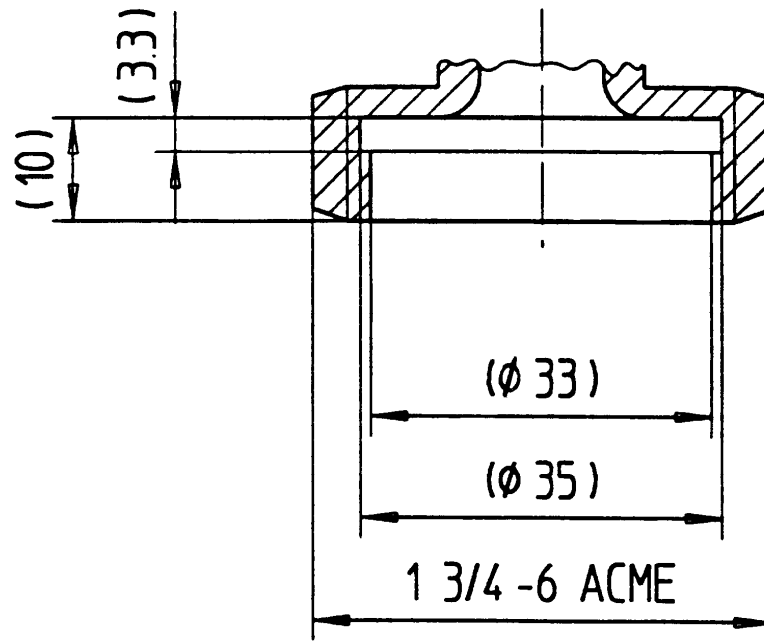

Figure 3: This filling unit applies only for motor vehicles of categories M2, M3, N2, N3 and M1 having a maximum total mass > 3500 kg. 1/

1/ See Consolidated Resolution on the Construction of Vehicles (R.E.3), Annex 7 (document TRANS/SC1/WP29/78/Amend.3).

Annex 10

PROVISIONS REGARDING THE APPROVAL OF LPG CONTAINERS

The meaning of symbols and terms used in this annex

- P_h = hydraulic test pressure in kPa;
- P_r = container bursting pressure measured in the bursting test, in kPa;
- R_e = minimum yield stress in N/mm² guaranteed by the material standard;
- R_m = minimum tensile strength in N/mm² guaranteed by the material standard
- R_{mt} = actual tensile strength, in N/mm²;
- a = calculated minimum thickness of the cylindrical shell wall, in mm;
- b = calculated minimum thickness of dished ends, in mm;
- D = nominal outside diameter of the container, in mm;
- R = inside radius of the dished end of the standard cylindrical container, in mm;
- r = inside knuckle of the dished end of the standard cylindrical container, in mm;
- H = outside height of dished part of container end, in mm;
- h = height of cylindrical part of dished end, in mm;
- L = length of container's stress-resistant shell, in mm;
- A = elongation value (per cent) of parent material;
- V_0 = initial volume of the container at the moment when the pressure is increased in the burst test, in dm³;
- V = final volume of the container on bursting, in dm³;
- g = gravity, in m/s²;
- c = shape factor;
- Z = stress reduction factor.

1. **TECHNICAL REQUIREMENTS**

1.1. **Dimensions**

For all dimensions without indication of tolerances, general tolerances of EN 22768-1 shall apply.

1.2. **Materials**

- 1.2.1. The material used for the manufacture of the stress-resistant container shells must be steel as specified in Euronorm 10120 (however, other materials may be used provided that the container has the same safety characteristics, to be certified by the authorities granting type approval).
- 1.2.2. The parent material refers to the material in the state before any specific transformation with regards to the manufacturing process has been carried out.
- 1.2.3. All components of the container body and all the parts welded thereto must be made of mutually compatible materials.
- 1.2.4. The filler materials must be compatible with the material so as to form welds with properties equivalent to those specified for the parent material.
- 1.2.5. The container manufacturer must obtain and provide chemical cast analysis certificates and mechanical properties of the material in respect of the steels or other materials applied for the construction of the parts subject to pressure.
- 1.2.6. The inspection authority must have the opportunity to make independent analyses. These analyses must be carried out either on specimens taken from the materials as supplied to the container manufacturer or on the finished containers.
- 1.2.7. The manufacturer must make available to the inspection authority the results of metallurgical and mechanical tests and analyses of parent and filler materials carried out on welds and must also provide it with a description of the welding methods and processes which can be regarded as representative of the welds made during production.

1.3. **Design temperatures and pressures**

1.3.1. **Design temperature**

The design operating temperature of the container shall be from -20 to 65°C.

For extreme operating temperatures exceeding the above-mentioned temperatures special test conditions are applicable which shall be agreed upon with the competent authority.

1.3.2. Design pressure

The design operating pressure of the container shall be: 3,000 kPa.

1.4. The heat treatment shall be according to the following requirements:

1.4.1. The heat treatment shall be carried out on the parts or on the complete container.

1.4.2. Those parts of a container having been deformed by more than 5 per cent must be submitted to the following heat treatment: normalize.

1.4.3. Containers with a wall thickness ≥ 5 mm must be submitted to the following heat treatment:

1.4.3.1. hot-rolled and normalized material: stress relieve or normalize;

1.4.3.2. material of a different kind: normalize.

1.4.4. The manufacturer must submit the procedure for the heat treatment used.

1.4.5. Localized heat treatment of a completed container is not permitted.

1.5. Calculation of the parts under pressure

1.5.1. The wall thickness of the cylindrical shell of the containers must not be less than that calculated by the formula:

1.5.1.1. Containers without longitudinal welds:

$$a = \frac{P_h \cdot D}{2000 \frac{R_e}{4/3} + P_h} = \frac{P_h \cdot D}{1500 R_e + P_h}$$

1.5.1.2. Containers with longitudinal welds:

$$a = \frac{P_h \cdot D}{2000 \frac{R_e}{4/3} \cdot z + P_h} = \frac{P_h \cdot D}{1500 R_e \cdot z + P_h}$$

- $z = 0.85$ where the manufacturer radiographs each weld intersection and 100 mm of the adjacent longitudinal weld and 50 mm (25 mm each side of the intersection) of the adjacent circumferential weld.

This test has to be performed per machine at the beginning and end of each work shift period from continuous production and per machine;

- z = 1 where each weld intersection and 100 mm of the adjacent longitudinal weld and 50 mm (25 each side of the intersection) of the adjacent circumferential weld is spot radiographed.

This test has to be performed at 10 per cent of the container production: the containers to be tested are chosen randomly. Should these radiograph tests reveal unacceptable defects, as defined in paragraph 2.4.1.4., all the necessary steps must be taken to examine the production run in question and eliminate the defects.

1.5.2. **Dimensions and calculations of ends** (see figures in appendix 4 to this annex).

1.5.2.1. The container ends shall be in one piece, shall encave to the pressure and shall have either a torispherical or an elliptical form (examples are given in appendix 5).

1.5.2.2. The container ends must fulfil the following conditions:

Torispherical ends

simultaneous limits:

$$0.003 D \leq b \leq 0.08 D$$

$$r \geq 0.1 D$$

$$R \leq D$$

$$H \geq 0.18 D$$

$$r \geq 2 b$$

$$h \geq 4 b$$

$$h \leq 0.15 D \quad (\text{not applicable for containers as shown in appendix 2 to this annex, Figure 2a})$$

Elliptical ends

simultaneous limits:

$$0.003 D \leq b \leq 0.08 D$$

$$H \geq 0.18 D$$

$$h \geq 4 b$$

$$h \leq 0.15 D \quad (\text{not applicable for containers as shown in appendix 2 to this annex, Figure 2a})$$

- 1.5.2.3. The thickness of these barrelled ends must not in toto be less than the figure calculated by means of the following formula:

$$b = \frac{P_h \cdot D}{1500 R_e} C$$

The shape factor C to be used for full ends is given in the table and in the graphs contained in appendix 4 to this annex.

The wall thickness of the cylindrical edge of the ends may not be less or differ more than 15 per cent from the smallest wall thickness of the shell.

- 1.5.3. The nominal wall thickness of the cylindrical part and of the barrelled end may not, under any circumstances; be less than:

$$\frac{D}{250} + 1 \text{ mm}$$

with a minimum of 1.5 mm.

- 1.5.4. The shell of the container may be made up of one, two or three parts. When the shell is made up from two or three parts, the longitudinal welds must be shifted/rotated with a minimum of 10 * the thickness of the container wall (10 * a). The ends must be in one piece and convex.

1.6. **Construction and workmanship**

1.6.1. **General requirements**

- 1.6.1.1. The manufacturer shall demonstrate by having a suitable quality control system that he has and maintains the manufacturing facilities and processes to ensure that containers produced satisfy the requirements of this annex.
- 1.6.1.2. The manufacturer must ensure through adequate supervision that the parent plates and pressed parts used to manufacture the containers are free from defects likely to jeopardize the safe use of the containers.

1.6.2. **Parts subjected to pressure**

- 1.6.2.1. The manufacturer must describe the welding methods and processes used and indicate the inspections carried out during production.

1.6.2.2. Technical welding requirements

The butt welds must be executed by an automatic welding process.

The butt welds on the stress-resistant shell may not be located in any area where there are changes of profile.

Angle welds may not be superimposed on butt welds and must be at least 10 mm away from them.

Welds joining parts making up the shell of the container must satisfy the following conditions (see figures given as examples in appendix 1 of this annex):

longitudinal weld: this weld is executed in the form of a butt weld on the full section of the material of the wall;

circumferential weld:

this weld is executed in the form of a butt weld on the full section of the material of the wall. A joggle weld is considered to be a special type of butt weld;

welds of the studded valve plate or ring shall be carried out according to appendix 1, figure 3.

A weld fixing the collar or supports to the container shall be either a butt or angle weld.

Welded mounting supports shall be welded in the circumferential way. The welds shall be strong enough to withstand vibration, braking actions and outside forces of at least 30 g in all directions.

In this case of butt welds, the misalignment of the joint faces may not exceed one-fifth of the thickness of the walls (1/5 a).

1.6.2.3. **Inspection of welds**

The manufacturer must ensure that the welds show continuous penetration without any deviation of the weld seam, and that they are free from defects likely to jeopardize the safe use of the container.

For containers in two pieces, a radiographical test has to be performed on the circumferential butt welds over 100 mm, with the exception of the welds in conformity with joggle weld on page 1 of appendix 1 of this annex. On one container selected at the beginning and end of each shift period from continuous production and, in the event of production being interrupted for a period of more than 12 hours, the first container welded should also be radiographed.

1.6.2.4. **Out-of-roundness**

The out-of-roundness of the cylindrical shell of the container must be limited so that the difference between the maximum and minimum outside diameter of the same cross-section is not more than 1 per cent of the average of those diameters.

1.6.3. **Fittings**

1.6.3.1. The supports must be manufactured and welded to the container body in such a way as not to cause dangerous concentrations of stresses or be conducive to the collection of water.

1.6.3.2. The base of the container must be sufficiently strong and made of metal compatible with the type of steel used for the container. The form of the base must give the container sufficient stability.

The top edge of the base must be welded to the container in such a way as not to be conducive to the collection of water nor to allow water to penetrate between the base and the container.

1.6.3.3. A reference mark shall be affixed on the containers to ensure their correct installation.

1.6.3.4. Where fitted, identification plates must be fixed on to the stress resistant shell and shall not be removable. All the necessary corrosion prevention measures must be taken.

1.6.3.5. The container shall have provisions to mount a gas-tight housing or kind of protection device over the container accessories.

1.6.3.6. Any other material, however, may be used for the manufacture of the supports, provided that its strength is assured and that all risk of the container end corroding is eliminated.

2. **TESTS**

2.1. **Mechanical tests**

2.1.1. **General requirements**

2.1.1.1. Where not covered by the requirements contained in this annex, the mechanical tests are to be carried out in accordance with Euronorms Nos:

(a) 2-80 or 11-80 respectively in the case of the tensile test according to whether the thickness of the testpiece is 3 mm or above, or less than 3 mm.

(b) 6-55 or 12-55 respectively in the case of the bend test, according to whether the thickness of the testpiece is 3 mm or above, or less than 3 mm.

2.1.1.2. All the mechanical tests for checking the properties of the parent metal and welds of the stress-resistant shells of the container are carried out on testpieces taken from finished containers.

2.1.2. **Types of test and evaluation of test results**

2.1.2.1. Each sample container is subjected to the following tests:

2.1.2.1.1. **Containers with longitudinal and circumferential welds** (three sections) on test-pieces taken from the places shown in figure 1 of appendix 2 of this annex:

- (a) One tensile test on parent material; the test piece to be taken in the longitudinal direction (if this is not possible, it may be taken in a circumferential direction);
- (b) One tensile test on parent material of the bottom;
- (c) One tensile test perpendicular to the longitudinal weld;
- (d) One tensile test perpendicular to the circumferential weld;
- (e) One bend test on the longitudinal weld, the inner surface in tension;
- (f) One bend test on the longitudinal weld, the outer surface in tension;
- (g) One bend test on the circumferential weld, the inner surface in tension;
- (h) One bend test on the circumferential weld, the outer surface in tension; and
- (i) One macroscopic test of a welded section;

(m1, m2) A minimum of two macroscopic tests of valve boss/plate sections in case of the sidewall mounted valves referred to in paragraph 2.4.2. below.

2.1.2.1.2. **Containers with circumferential welds only** (two sections) on test-pieces taken from the places shown in figures 2a and 2b of appendix 2 to this annex:

The tests as specified in paragraph 2.1.2.1.1. above with the exception of (c), (e) and (f) which are not applicable. The test-piece for the tensile test on parent material shall be taken from (a) or (b) as mentioned in paragraph 2.1.2.1.1. above.

- 2.1.2.1.3. Test-pieces which are not sufficiently flat must be flattened by cold pressing.
- 2.1.2.1.4. In all test pieces containing a weld, the weld is machined to trim the surplus.
- 2.1.2.2. **Tensile test**
- 2.1.2.2.1. **Tensile test on parent metal**
- 2.1.2.2.1.1. The procedure for carrying out the tensile test is that given in the appropriate Euronorm in accordance with paragraph 2.1.1.1.
- The two faces of the test-piece representing the inside and outside walls of the container respectively must not be machined.
- 2.1.2.2.1.2. The values determined for yield stress, tensile strength and elongation after the parent metal bursts must comply with Euronorm 10120 (Table 11).
- 2.1.2.2.2. **Tensile test on welds**
- 2.1.2.2.2.1. This tensile test perpendicular to the weld must be carried out on a test-piece having a reduced cross-section 25 mm in width for a length extending up to 15 mm beyond the edges of the weld, as shown in figure 2 of appendix 3 to this annex.
- Beyond this central part the width of the test-piece must increase progressively.
- 2.1.2.2.2.2. The tensile strength value obtained must be at least equal to that guaranteed for the parent metal irrespective of where the burst occurs in the cross-section of the central part of the test-piece.
- 2.1.2.3. **Bend test**
- 2.1.2.3.1. The procedure for carrying out the bend test is that given in the appropriate Euronorm in accordance with paragraph 2.1.1.1. The bend test must, however, be carried out transversely to the weld on a test-piece 25 mm in width. The mandrel must be placed in the centre of the weld while the test is being performed.
- 2.1.2.3.2. Cracks must not appear in the test-piece when it is bent round a mandrel as long as the inside edges are separated by a distance not greater than the diameter of the mandrel + 3a (see figure 1 in appendix 3 of this annex).
- 2.1.2.3.3. The ratio (n) between the diameter of the mandrel and the thickness of the test piece must not exceed the values given in the following table:

Actual tensile strength R _t in (N/mm ²)	Value (n)
Up to 440 inclusive	2 3
above 440 to 520 inclusive	4
above 520	

2.1.2.4. Retesting is permitted for the tensile and bend test. A second test shall consist of two test pieces taken from the same container.

If the results of these tests are satisfactory, the first test shall be ignored.

In the event where one or both of the retests fail to meet the requirements, the batch shall be rejected.

2.2. **Burst test under hydraulic pressure**

2.2.1. **Test conditions**

Containers subjected to this test must bear the inscriptions which it is proposed to affix on the section of the container subjected to pressure,

2.2.1.1. The burst test under hydraulic pressure must be carried out with equipment which enables the pressure to be increased at an even rate, until the container bursts and the change in pressure over time to be recorded. The maximum flowrate during the test should not exceed 3 per cent of the capacity of the container per minute.

2.2.2. **Interpretation of test**

2.2.2.1. The criteria adopted for the interpretation of the burst test are as follows:

2.2.2.1.1. Volumetric expansion of the container; it equals:

volume of water used between the time when the pressure starts to rise and the time of bursting.

2.2.2.1.2. Examination of the tear and the shape of its edges.

bursting pressure;

volume of water used between the time when the pressure starts to rise and the time of bursting, which shows the volumetric expansion of the container;

examination of the tear and the shape of its edges.

2.2.3. **Test acceptance conditions**

2.2.3.1. The measured bursting pressure (P_r) must not under any circumstances be less than $2.25 \cdot 3,000 = 6,750$ kPa.

2.2.3.2. The specific change in the volume of the container at the time of bursting must not be less than:

20 per cent if the length of the container is greater than the diameter;

17 per cent if the length of the container is equal to or less than the diameter.

8 per cent in the case of a special container as shown in appendix 5, page 1, Figures A, B and C.

2.2.3.3. The burst test must not cause any fragmentation of the container.

2.2.3.3.1. The main fracture must not show any brittleness, i.e. the edges of the fracture must not be radial but must be at an angle to a diametrical plane and display a reduction of area throughout their thickness.

2.2.3.3.2. The fracture must not reveal an inherent defect in the metal. The weld must be at least as strong as the original metal but preferably stronger.

2.2.3.4. Retesting is permitted for the burst test. A second burst test shall be performed on two containers which have been produced successively to the first container within the same batch. If the results of these tests are satisfactory, the first test shall be ignored. In the event where one or both of the retests fail to meet the requirements, the batch shall be rejected.

2.3. **Hydraulic test**

2.3.1. The containers representative of the type of container submitted for approval (without accessories but with the outlets closed off) shall withstand an inner hydraulic pressure of 3,000 kPa without leakages or becoming permanently distorted, according to the following requirements:

2.3.2. The water pressure in the container must increase at an even rate until the test pressure of 3,000 kPa is reached.

2.3.3. The container must remain under the test pressure long enough to make it possible to establish that the pressure is not falling off and that the container can be guaranteed leakproof.

- 2.3.4. After the test the container must show no signs of permanent deformation.
- 2.3.5. Any container tested which does not pass the test must be rejected.
- 2.4. **Non-destructive examination**
- 2.4.1. **Radiographic examination**
- 2.4.1.1. Welds must be radiographed in compliance with ISO specification R 1106, using classification B.
- 2.4.1.2. When a wire-type indicator is used, the smallest diameter of the wire visible may not exceed the value of 0.10 mm.
- When a stepped and holed type indicator is used, the diameter of the smallest hole visible may not exceed 0.25 mm.
- 2.4.1.3. Assessment of the weld radiographs must be based on the original films in compliance with the practice recommended in ISO standard 2504, paragraph 6.
- 2.4.1.4. The following defects are not acceptable:
- Cracks, inadequate welds or inadequate penetration of the weld.
- 2.4.1.4.1. For the container wall thickness ≥ 4 mm, the inclusions listed below are regarded as acceptable:
- Any gas inclusion measuring not more than $a/4$ mm;
- Any gas inclusion measuring more than $a/4$ mm but not more than $a/3$ mm, which is more than 25 mm away from other gas inclusion measuring more than $a/4$ mm and measuring not more than $a/3$ mm;
- Any elongated inclusion or any group of rounded inclusions in a row where the length represented (over a weld length of 12a) is not greater than 6 mm;
- Gas inclusions over any 100 mm weld length, where the total area of all the figures is not greater than $2 a \text{ mm}^2$.
- 2.4.1.4.2. For the container wall thickness < 4 mm, the inclusions listed below are regarded as acceptable:
- Any gas inclusion measuring not more than $a/2$ mm;
- Any gas inclusion measuring more than $a/2$ mm but not more than $a/1.5$ mm, which is more than 25 mm away from other gas inclusion measuring more than $a/2$ mm and measuring not more than $a/1.5$ mm;

Any elongated inclusion or any group of rounded inclusions in a row where the length represented (over a weld length of 12a) is not greater than 6 mm;

Gas inclusions over any 100 mm weld length, where the total area of all the figures is not greater than 2 a mm².

2.4.2. **Macroscopic examination**

The macroscopic examination of a full transverse section of the weld must show a complete fusion on the surface treated with any acid from the macro-preparation and must not show any assembly fault or a significant inclusion or other defects.

In case of doubt, a microscopic examination should be made of the suspect area.

2.5. **Examination of the outside of the weld**

2.5.1. This examination is carried out when the weld has been completed.

The welded surface examined must be well illuminated, and must be free from grease, dust, scale residue or protective coating of any kind.

2.5.2. The fusion of the welded metal with the parent metal must be smooth and free from etching. There must be no cracks, notching or porous patches in the welded surface and the surface adjacent to the wall. The welded surface must be regular and even. Where a butt weld has been used, the excess thickness must not exceed 1/4 of the width of the weld.

Annex 10 - Appendix 1

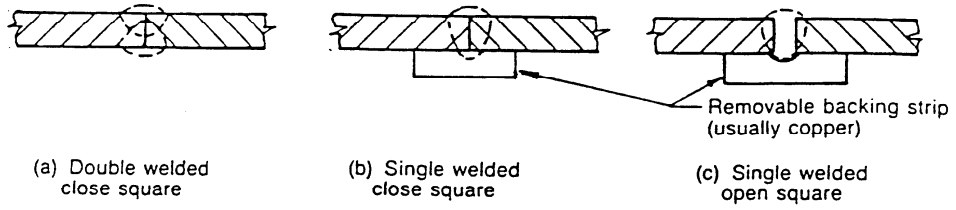

types of main longitudinal butt welds

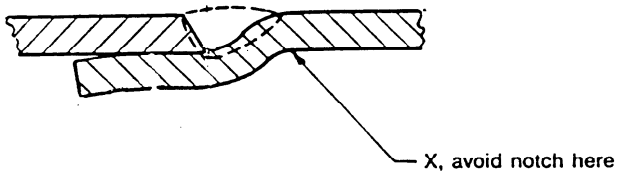

joggle weld

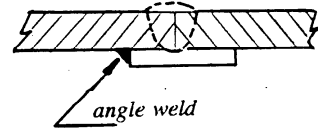

weld on backing strip

Note : The angle weld can be performed as a "chain-weld"

circumferential butt weld

Annex 10 - Appendix 1 (cont'd)

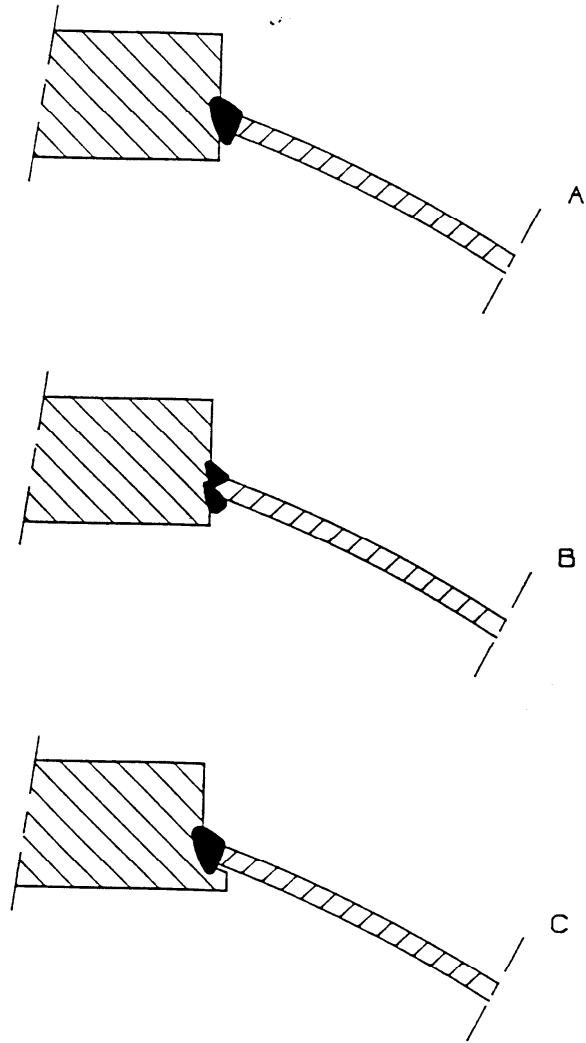

FIGURE 3: EXAMPLES OF WELDED STUDDED PLATES

Annex 10 - Appendix 1 (cont'd)

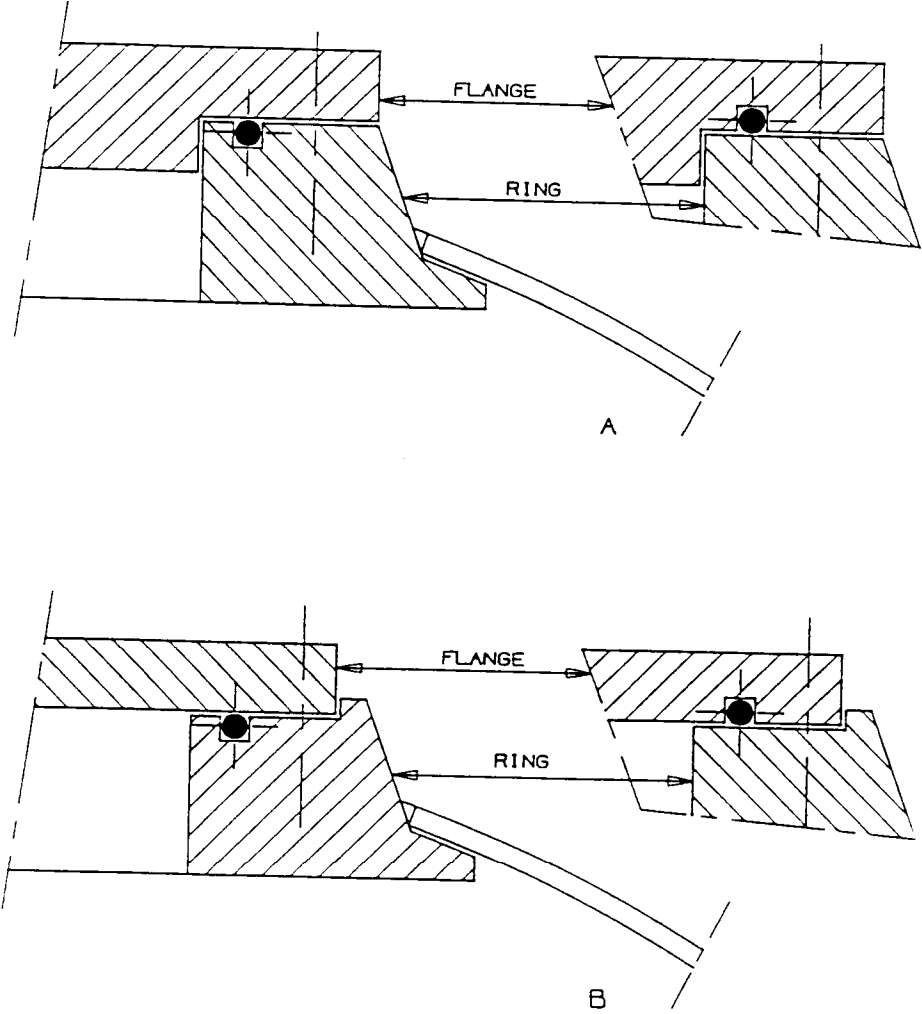

FIGURE 4: EXAMPLES OF WELDED RINGS WITH FLANGE

Annex 10 - Appendix 2

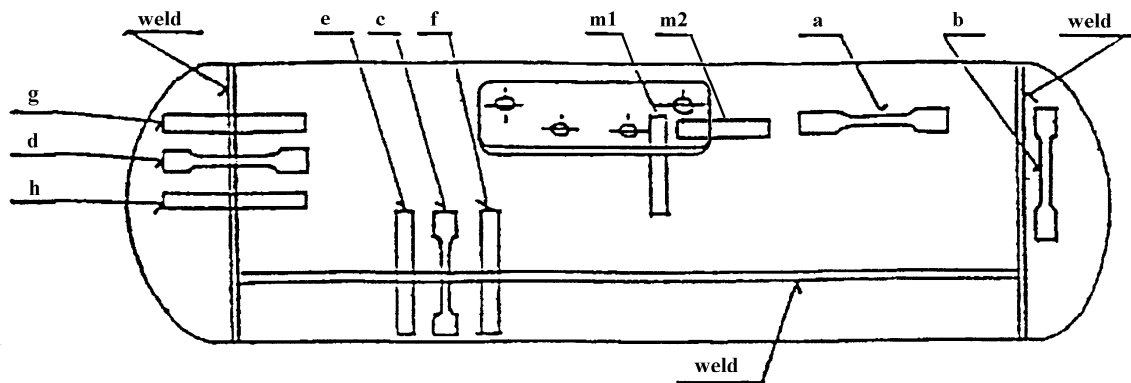
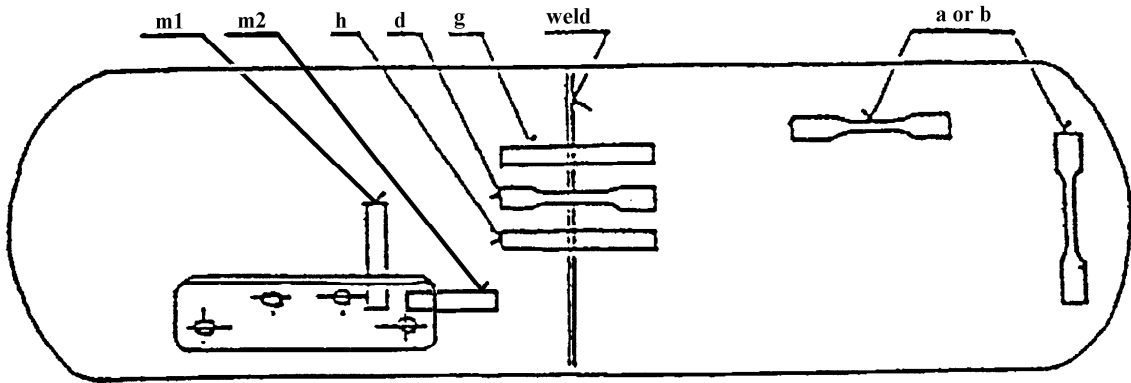

FIGURE 1:

- (a) tensile test on parent material
- (b) tensile test on parent material of the bottom
- (c) tensile test on a longitudinal weld
- (d) tensile test on a circumferential weld
- (e) bend test on a longitudinal weld, the inner surface in tension
- (f) bend test on a longitudinal weld, the outer surface in tension
- (g) bend test on a circumferential weld, the inner surface in tension
- (h) bend test on a circumferential weld, the outer surface in tension
- (m1, m2) macrosections through valve boss/plate welds (side-mounted valve block)

FIGURE 1: Containers with longitudinal and circumferential welds, Location of test-pieces

Annex 10 - Appendix 2 (cont'd)



- (a) or (b) tensile test on parent material
- (d) tensile test on a circumferential weld
- (g) bend test on a circumferential weld, the inner surface in tension
- (h) bend test on a circumferential weld, the outer surface in tension
- (m1, m2) macrosections through valve boss/plate welds (side-mounted valve block)

FIGURE 2a: Containers with circumferential welds only and side-mounted valve blocks; Location of test-pieces

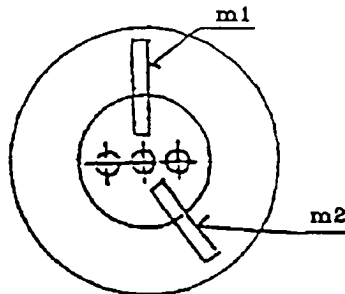

- (m1, m2) macrosections through valve boss/plate welds
(Refer to figure 2a for other locations of test-pieces)

FIGURE 2b: Containers with circumferential welds only and valve boss/plate fitted to the end.

Annex 10 - Appendix 3

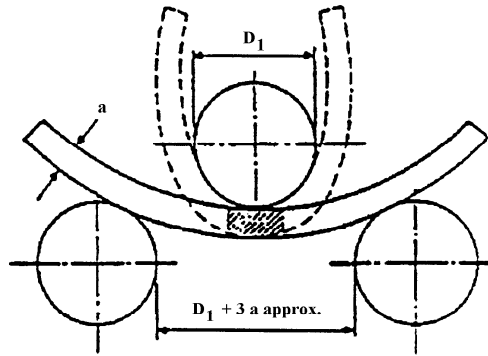

FIGURE 1
ILLUSTRATION OF BEND TEST

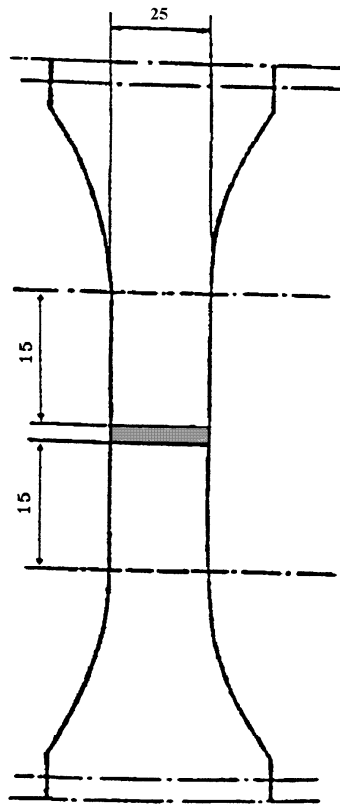
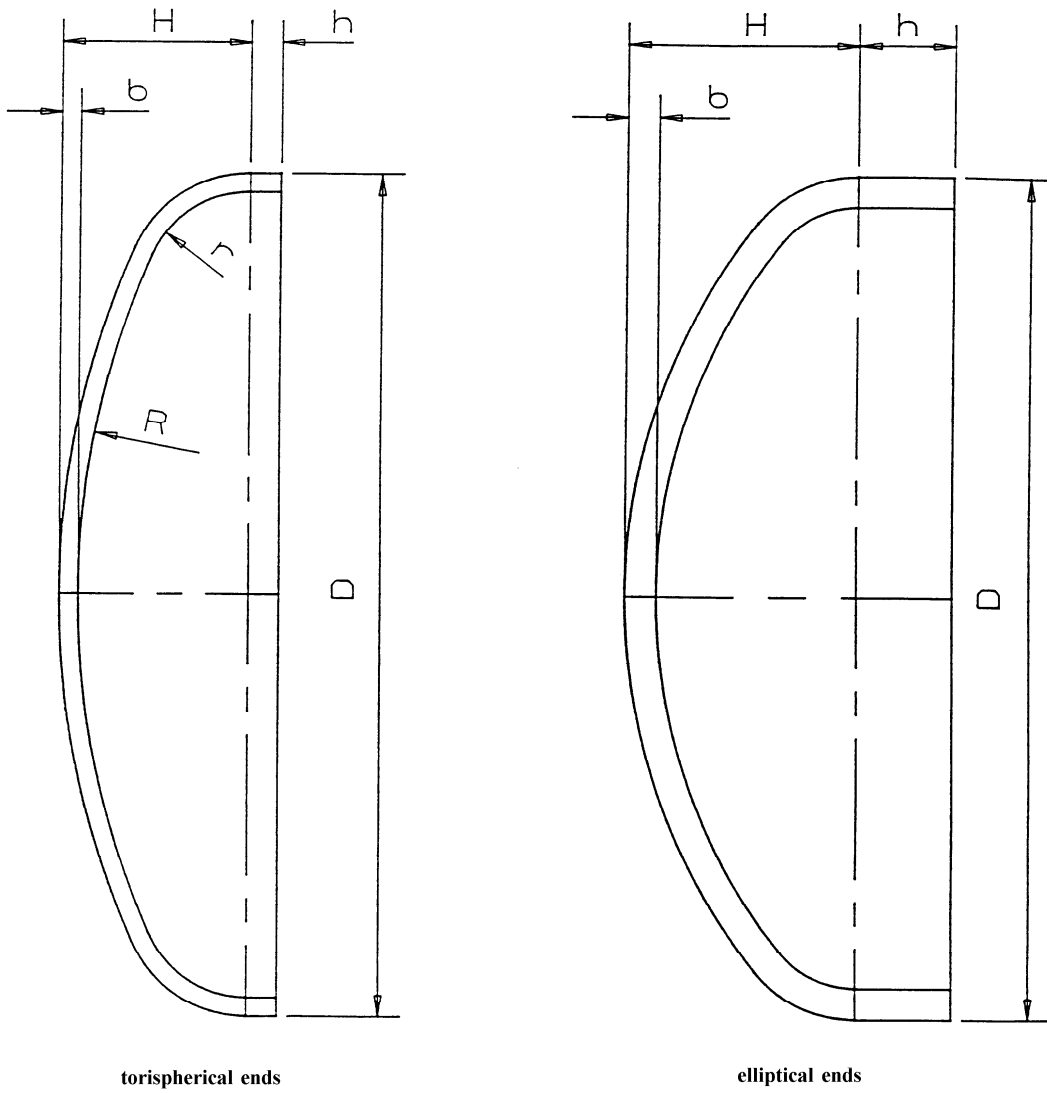

FIGURE 2: TEST PIECE FOR TENSILE TEST PERPENDICULAR TO THE WELD

Annex 10 - Appendix 4



Note: for torispherical ends

$$H = (R + b) - \sqrt{\left[\left(R + b \right) - \frac{D}{2} \right] \left[\left(R + b \right) + \frac{D}{2} - 2(r + b) \right]}$$

Annex 10 - Appendix 4 (cont'd)

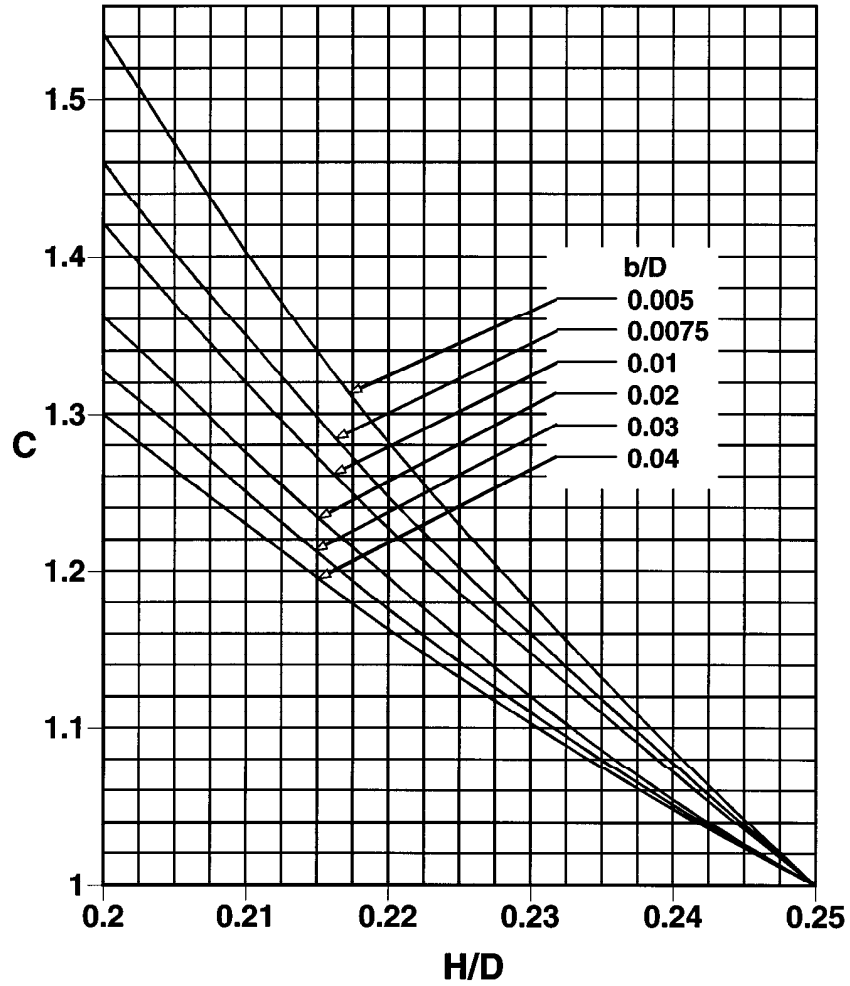

for H/D between 0.25 and 0.5
values of shape factor C

Annex 10 - Appendix 4 (cont'd)

Relationship between H/D and Design factor C

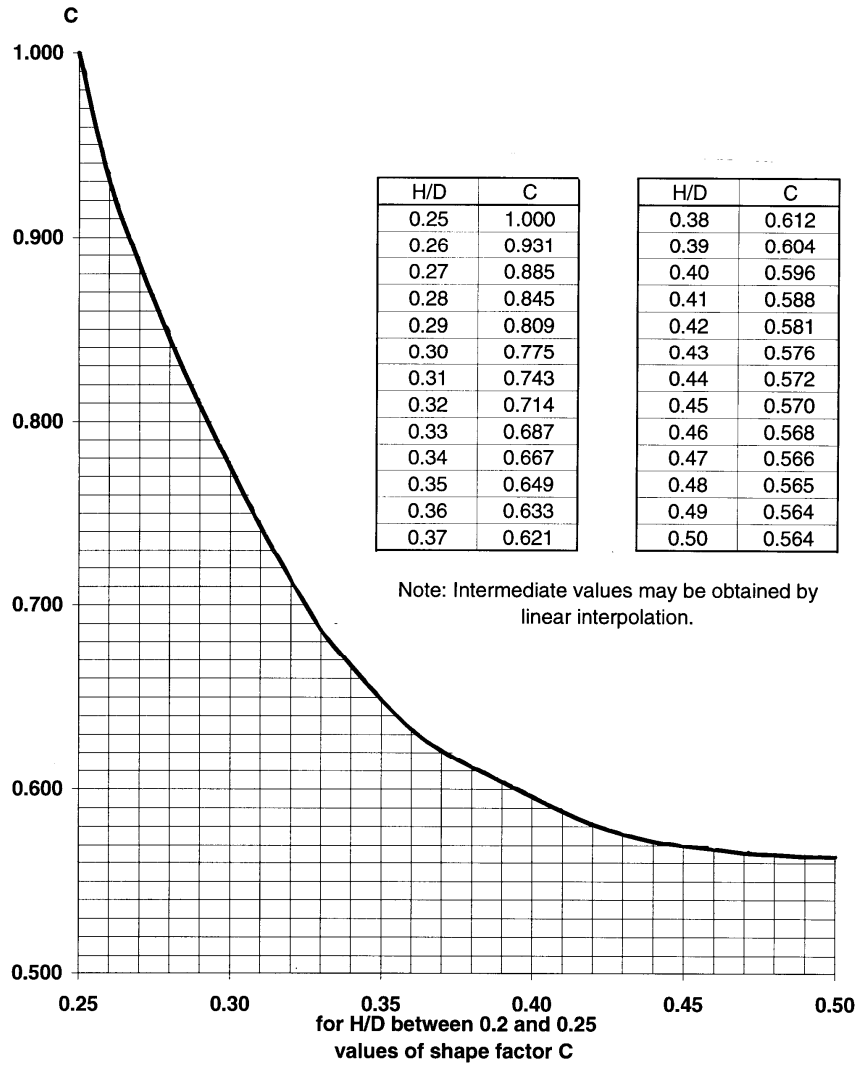

Annex 10 - Appendix 5
EXAMPLES OF SPECIAL VESSELS

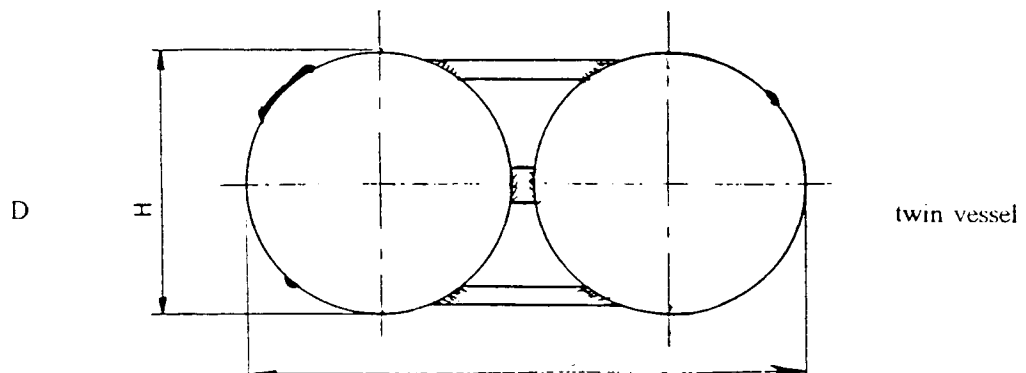
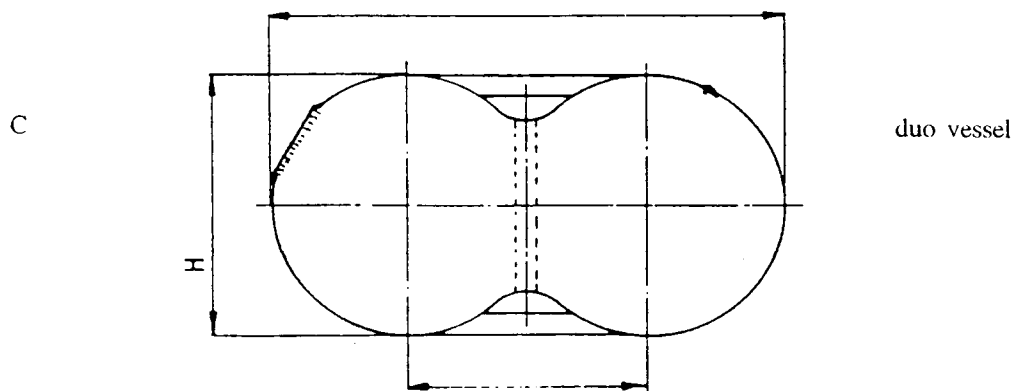
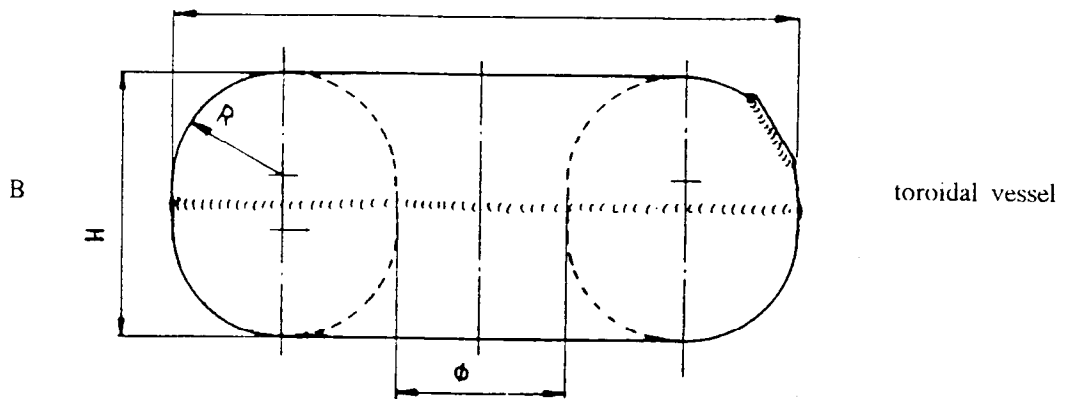
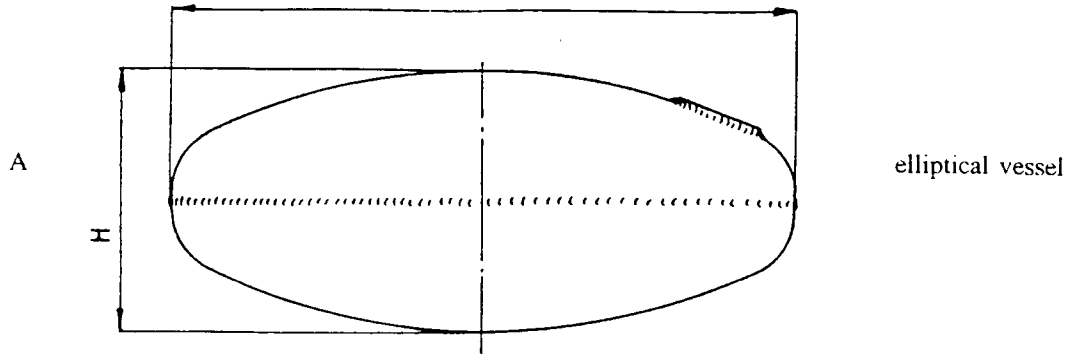

Annex 10 - Appendix 5 (cont'd)

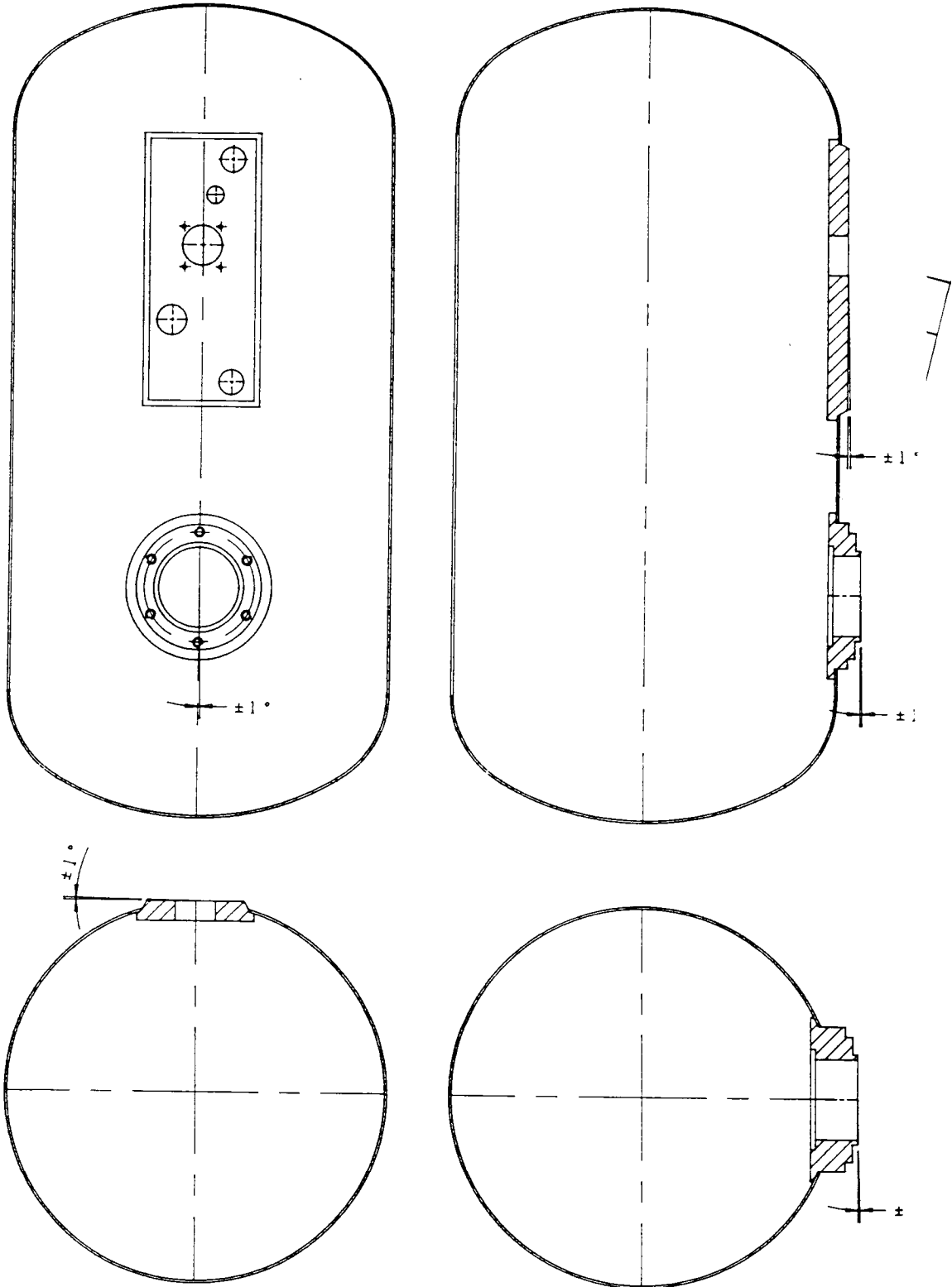

Annex 11

**PROVISIONS REGARDING THE APPROVAL OF GAS INJECTION DEVICES,
OR GAS MIXING PIECES, OR INJECTORS AND THE FUEL RAIL**

- 1. Gas injection device or injector**
- 1.1. Definition: see paragraph 2.14. of this Regulation.
- 1.2. Component classification (according to figure 1, para. 2): Class 1.
- 1.3. Classification pressure: 3,000 kPa.
- 1.4. Design temperatures:
-20°C to 120°C
For temperatures exceeding the above-mentioned values, special tests conditions are applicable.
- 1.5. General design rules:
Paragraph 6.14.2., Provisions regarding the electrical insulation.
Paragraph 6.14.2., Provisions regarding the insulation class.
Paragraph 6.14.3.1., Provisions when the power is switched off.
Paragraph 6.14.4.1., Heat exchange medium (compatibility and pressure requirements).
- 1.6. Applicable test procedures:
- | | |
|------------------------|-------------------------------|
| Over pressure test | Annex 15, para. 4 |
| External leakage | Annex 15, para. 5 |
| High temperature | Annex 15, para. 6 |
| Low temperature | Annex 15, para. 7 |
| LPG compatibility | Annex 15, para. 11 <u>**/</u> |
| Corrosion resistance | Annex 15, para. 12 |
| Resistance to dry heat | Annex 15, para. 13 |
| Ozone ageing | Annex 15, para. 14 <u>**/</u> |
| Creep | Annex 15, para. 15 <u>**/</u> |
| Temperature cycle | Annex 15, para. 16 <u>**/</u> |

*/ only for metallic parts

**/ only for non-metallic parts

2. Gas injection device or gas mixing piece

2.1. Definition: see paragraph 2.14. of this Regulation.

2.2. Component classification (according to figure 1, para. 2):

Class 2: for the part with a maximum regulated pressure during operation of 450 kPa.

Class 2A: for the part with a maximum regulated pressure during operation of 120 kPa.

2.3. Classification pressure:

Parts of Class 2: 450 kPa.

Parts of Class 2A: 120 kPa.

2.4. Design temperatures:

-20°C to 120°C, when the fuel pump is mounted outside the container.

For temperatures exceeding the above-mentioned values, special tests conditions are applicable.

2.5. General design rules:

Paragraph 6.14.2., Provisions regarding the electrical insulation.

Paragraph 6.14.2., Provisions regarding the insulation class.

Paragraph 6.14.3.1., Provisions when the power is switched off.

Paragraph 6.14.4.1., Heat exchange medium (compatibility and pressure requirements).

2.6. Applicable test procedures:

Over pressure test	Annex 15, para. 4
External leakage	Annex 15, para. 5
High temperature	Annex 15, para. 6
Low temperature	Annex 15, para. 7
LPG compatibility	Annex 15, para. 11 <u>**/</u>
Corrosion resistance	Annex 15, para. 12

*/ only for metallic parts

**/ only for non-metallic parts

3. Fuel rail

- 3.1. Definition: see paragraph 2.22. of this Regulation.
- 3.2. Component classification (according to figure 1, para. 2):
Fuel rails can be of Class 1, 2 or 2A.
- 3.3. Classification pressure:
Parts of Class 1: 3,000 kPa.
Parts of Class 2: 450 kPa.
Parts of Class 2A: 120 kPa.
- 3.4. Design temperatures:
-20°C to 120°C
For temperatures exceeding the above-mentioned values, special tests conditions are applicable.
- 3.5. General design rules: (not used)
- 3.6. Applicable test procedures:
 - 3.6.1. For fuel rails of Class 1:

Over pressure test	Annex 15, para. 4
External leakage	Annex 15, para. 5
High temperature	Annex 15, para. 6
Low temperature	Annex 15, para. 7
LPG compatibility	Annex 15, para. 11 <u>**/</u>
Corrosion resistance	Annex 15, para. 12
Resistance to dry heat	Annex 15, para. 13
Ozone ageing	Annex 15, para. 14 <u>**/</u>
Creep	Annex 15, para. 15 <u>**/</u>
Temperature cycle	Annex 15, para. 16 <u>**/</u>
 - 3.6.2. For fuel rails of Class 2 and/or 2A:

Over pressure test	Annex 15, para. 4
External leakage	Annex 15, para. 5
High temperature	Annex 15, para. 6
Low temperature	Annex 15, para. 7
LPG compatibility	Annex 15, para. 11 <u>**/</u>
Corrosion resistance	Annex 15, para. 12

*/ only for metallic parts

**/ only for non-metallic parts

Annex 12**PROVISIONS REGARDING THE APPROVAL OF THE GAS DOSAGE UNIT WHEN NOT COMBINED WITH THE GAS INJECTION DEVICE(S)**

1. Definition: see paragraph 2.15. of this Regulation.
2. Component classification (according to figure 1, para. 2):

Class 2: for the part with a maximum regulated pressure during operation of 450 kPa.
Class 2A: for the part with a maximum regulated pressure during operation of 120 kPa.
3. Classification pressure:

Parts of Class 2: 450 kPa.
Parts of Class 2A: 120 kPa.
4. Design temperatures:

-20°C to 120°C
For temperatures exceeding the above-mentioned values, special tests conditions are applicable.
5. General design rules:

Paragraph 6.14.2., Provisions regarding the electrical insulation.
Paragraph 6.14.3.1., Provisions on valves activated by electrical power.
Paragraph 6.14.4., Heat exchange medium (compatibility and pressure requirements).
Paragraph 6.14.5., Overpressure bypass security.
6. Applicable test procedures:

Over pressure test	Annex 15, para. 4
External leakage	Annex 15, para. 5
High temperature	Annex 15, para. 6
Low temperature	Annex 15, para. 7
LPG compatibility	Annex 15, para. 11 <u>**/</u>
Corrosion resistance	Annex 15, para. 12

Remarks:

The parts of the gas dosage unit (Class 2 or 2A) shall be leakproof with the outlet(s) of that part closed.

For the overpressure test all the outlets including those of the coolant compartment shall be closed off.

*/ only for metallic parts

**/ only for non-metallic parts

Annex 13

PROVISIONS REGARDING THE APPROVAL OF THE PRESSURE AND/OR TEMPERATURE SENSOR

1. Definition:

Pressure sensor: see paragraph 2.17. of this Regulation.
Pressure sensor: see paragraph 2.17. of this Regulation.
2. Component classification (according to figure 1, para. 2):

Pressure and temperature sensors can be of Class 1, 2 or 2A.
3. Classification pressure:

Parts of Class 1: 3,000 kPa.
Parts of Class 2: 450 kPa.
Parts of Class 2A: 120 kPa.
4. Design temperatures:

-20°C to 120°C
For temperatures exceeding the above-mentioned values, special tests conditions are applicable.
5. General design rules:

Paragraph 6.14.2., Provisions regarding the electrical insulation.
Paragraph 6.14.4.1., Heat exchange medium (compatibility and pressure requirements).
Paragraph 6.14.6.2., Gas flow prevention.
6. Applicable test procedures:
 - 6.1. For parts of Class 1:

Over pressure test	Annex 15, para. 4
External leakage	Annex 15, para. 5
High temperature	Annex 15, para. 6
Low temperature	Annex 15, para. 7
LPG compatibility	Annex 15, para. 11 **/
Corrosion resistance	Annex 15, para. 12 */
Resistance to dry heat	Annex 15, para. 13
Ozone ageing	Annex 15, para. 14 **/
Creep	Annex 15, para. 15 **/
Temperature cycle	Annex 15, para. 16 **/

*/ only for metallic parts

**/ only for non-metallic parts

6.2. For parts of Class 2 or 2A:

Over pressure test	Annex 15, para. 4
External leakage	Annex 15, para. 5
High temperature	Annex 15, para. 6
Low temperature	Annex 15, para. 7
LPG compatibility	Annex 15, para. 11 <u>**/</u>
Corrosion resistance	Annex 15, para. 12

*/ only for metallic parts

**/ only for non-metallic parts

Annex 14

PROVISIONS REGARDING THE APPROVAL OF THE ELECTRONIC CONTROL UNIT

1. The electronic control unit can be any device which controls the LPG demand of the engine and establishes the cut-off of the remotely-controlled service valve(s), cut-off valves and fuel pump of the LPG-system in case of a broken fuel supply pipe or/and in case of stalling of the engine.
 2. The switching off delay of the service cut-off valves after stalling of the engine may not be more than 5 seconds.
 3. The electronic control unit shall comply with relevant electromagnetic compatibility (E.M.C) requirements according to Regulation No. 10, 02 series of amendments or equivalent.
 4. Electrical failure of the vehicle system may not lead to uncontrolled opening of any valve.
 5. The output of the electronic control unit shall be inactive when the electric power is switched off or removed.
-

Annex 15 1/**TEST PROCEDURES****1. Classification**

1.1.1. LPG components for use in vehicles shall be classified with regard to the maximum operating pressure and function, according to Chapter 2 of this Regulation.

1.2. The classification of the components determines the tests which have to be performed for type approval of the components or parts of the components.

2. Applicable test procedures

In table 1 the applicable test procedures dependent on the classification are shown.

Table 1

Test	Class 1	Class 2(A)	Class 3	Paragraph
Overpressure	x	x	x	4.
External leakage	x	x	x	5.
High temperature	x	x	x	6.
Low temperature	x	x	x	7.
Seat leakage	x		x	8.
Endurance / Functional tests <u>1/</u>	x		x	9.
Operational test <u>3/</u>			x	10.
LPG compatibility <u>2/</u>	x	x	x	11.
Corrosion resistance	x	x	x	12.
Resistance to dry heat	x			13.
Ozone ageing	x			14.
Creep <u>2/</u>	x		x	15.
Temperature cycle <u>2/</u>	x		x	16.

1/ For parts subjected to a functional test see paragraph 8 of this annex.

2/ Only applicable for non-metallic parts.

3/ Only applicable for parts mentioned in paragraph 8.

Class 1 and 3 components should withstand a pressure of 6,750 kPa and Class 2 a pressure of 1,015 kPa.

The materials used for the components shall have written specifications that fulfil at least or exceed the (test) requirements laid down in this document with respect to:

- (i) temperature
- (ii) pressure
- (iii) LPG compatibility
- (iv) durability

3. **General requirements**

- 3.1. Leakage tests shall have to be conducted with pressurized gas like air or nitrogen.
- 3.2. Water or another fluid may be used to obtain the required pressure for the hydrostatic strength test.
- 3.3. All test values shall indicate the type of test medium used, if applicable.
- 3.4. The test period for leakage- and hydrostatic strength-tests shall be not less than 1 minute.
- 3.5. All tests shall be performed at a room temperature of $20^{\circ}\text{C} \pm 5^{\circ}\text{C}$, unless otherwise stated.

4. **Overpressure test under hydraulic conditions**

A LPG containing component shall withstand without any visible evidence of rupture or permanent distortion a hydraulic test pressure which is determined by Table 1 (of 2.25 times the maximum classification pressure) during minimal 1 minute with the outlet of the high pressure part plugged.

The samples, previously subjected to the durability test of paragraph 7 are to be connected to a source of hydrostatic pressure. A positive shut-off valve and a pressure gauge, having a pressure of not less than 1.5 times nor more than 2 times the test pressure, are to be installed in the hydrostatic pressure supply piping.

Table 1 shows the classification pressure and the pressures to be used in the over-pressure test according to the classification:

Classification of component	Classification pressure [kPa]	Hydraulic test pressure for over-pressure test [kPa]
Class 1, 3	3,000	6,750
Class 2A	120	270
Class 2	450	1,015

5. External leakage test

5.1. A component shall be free from leakage through stem or body seals or other joints, and shall not show evidence of porosity in casting when tested as described in paragraph 5.2. at any aerostatic pressure between 0 and the pressure shown in table 2.

5.2. The test shall be performed at the following conditions:

- (i) at room temperature
- (ii) at the minimum operating temperature
- (iii) at the maximum operating temperature

The maximum and minimum operating temperatures are given in the annexes.

5.3. During this test the equipment under test (EUT) will be connected to a source of aerostatic pressure (of 1.5 times the maximum classification pressure). A positive shut-off valve and a pressure gauge having a pressure range of not less than 1.5 times nor more than 2 times the test pressure are to be installed in the pressure supply piping. The pressure gauge is to be installed between the positive shut-off valve and the sample under test. While under the applied test pressure, the sample should be submerged in water to detect leakage or any other equivalent test method (flow measurement or pressure drop).

Table 2: the classification and leakage test pressures according to the classification:

Classification of component	Classification pressure [kPa]	Test pressure for leakage test [kPa]
Class 1	3,000	4,500
Class 2A	120	180
Class 2	450	675
Class 3	3,000	6,750

5.4. The external leakage must be lower than the requirements stated in the annexes or, if no requirements are mentioned, the external leakage shall be lower than 15 cm³/hour with the outlet plugged, when submitted to a gas pressure equal to the leakage test pressure.

6. **High temperature test**

A LPG containing component shall not leak more than 15 cm³/hour with the outlet plugged when submitted to a gas pressure at maximum operating temperature, as indicated in the annexes, equal to the leakage test pressure (Table 2, paragraph 5.3.). The component shall be conditioned for at least 8 hours at this temperature.

7. **Low temperature test**

A LPG containing component shall not leak more than 15 cm³/hour with the outlet plugged when submitted to a gas pressure, at the minimum operating temperature (-20°C), equal to the leakage test pressure (Table 2, paragraph 5.3.). The component shall be conditioned for at least 8 hours at this temperature.

8. **Seat leakage test**

8.1. The following tests for seat leakage are to be conducted on samples of service valve or filling unit which have previously been subjected to the external leak test of paragraph 3 above.

8.1.1. Seat leakage tests are conducted with the inlet of the sample valve connected to a source of aerostatic pressure, the valve in the closed position, and with the outlet open. A positive shut-off valve and a pressure gauge having a pressure range of not less than 1.5 times nor more than 2 times the test pressure are to be installed in the pressure supply piping. The pressure gauge is to be installed between the positive shut-off valve and the sample under test. While under the applied test pressure, observations for leakage are to be made with the open outlet submerged in water unless otherwise indicated.

8.1.2. Conformance with paragraphs 8.2. and 8.3. of the Regulation is to be determined by connecting a length of tubing to the valve outlet. The open end of this outlet tube is to be located within an inverted graduated cylinder which is calibrated in cubic centimetres. The inverted cylinder is to be closed by a water seal. The apparatus is to be adjusted so that:

- (1) the end of the outlet tube is located approximately 13 mm above the water level within the inverted graduated cylinder, and
- (2) the water within and exterior to the graduated cylinder is at the same level. With these adjustments made, the water level within the graduated cylinder is to be recorded. With the valve in the closed position assumed as the result of normal operation, air or nitrogen at the specified test pressure is to be applied to the valve inlet for a test period of not less than 2 minutes. During this time, the vertical position of the graduated cylinder is to be adjusted, if necessary, to maintain the same water level within and exterior to it.

At the end of the test period and with the water within and exterior to the graduated cylinder at the same level, the level of water within the graduated cylinder is again recorded. From the change of volume within the graduated cylinder, the leakage rate is to be calculated according to the following formula:

$$V_1 = V_t \cdot \frac{60}{t} \cdot \left(\frac{273}{T} \cdot \frac{P}{101.6} \right)$$

Where:

V_1 = leakage rate, cubic centimetres of air or nitrogen per hour.

V_t = increase in volume within graduated cylinder during test.

t = time of test, minutes.

P = barometric pressure during test, in kPa.

T = ambient temperature during test, in K.

- 8.1.3. Instead of the method described above, leakage may be measured by a flowmeter installed on the inlet side of the valve under test. The flowmeter shall be capable of indicating accurately, for the test fluid employed, the maximum leakage flow rates permitted.
- 8.2. The seat of a shut-off valve, when in the closed position, shall be free from leakage at any aerostatic pressure between 0 to 3,000 kPa.
- 8.3. A non-return valve provided with a resilient seat, when in the closed position, shall not leak when subjected to any aerostatic pressure between 50 and 3,000 kPa.

- 8.4. A non-return valve provided with a metal-to-metal seat, when in the closed position, shall not leak at a rate exceeding 0.50 dm³/hour of air when subjected to an inlet pressure up to the test pressure according to Table 2 in paragraph 5.3.
- 8.5. The seat of the upper non-return valve used in the assembly of a filling unit, when in the closed position, shall be free from leakage at any aerostatic pressure between 50 and 3,000 kPa.
- 8.6. The seat of a service coupling, when in the closed position, shall be free from leakage at any aerostatic pressure between 0 to 3,000 kPa.
- 8.7. The gas-tube pressure relief valve shall not have internal leakage up to 3,000 kPa.
- 8.8. The pressure relief valve (discharge valve) shall not have internal leakage up to 2,300 kPa.
9. **Endurance test**
 - 9.1. A filling unit or service valve shall be capable of conforming to the applicable leakage test requirements of paragraphs 3.1. and 6.2., or 3.1. and 6.4., after being subjected to a number of cycles of opening and closing as mentioned in the annexes.
 - 9.2. A shut-off valve is to be tested with the valve outlet plugged. The valve body filled with n-hexane, and the valve inlet subjected to a pressure of 3,000 kPa.
 - 9.3. An endurance test is to be conducted at a rate not faster than 10 times per minute. For a shut-off valve, the closing torque is to be consistent with the size of handwheel, wrench, or other means employed to operate the valve.
 - 9.4. The appropriate tests for external and seat leakage, as described under external leakage test under paragraph 3 and seat leakage test under paragraph 6 are to be conducted immediately following the endurance test.
10. **Operational tests**
 - 10.1. **Operation test of the (gas-tube) pressure relief valve**
 - 10.1.1. In the case of pressure relief valves, three samples of each size, design, and setting are to be used for start-to-discharge and resealing pressure tests. This same set of three valves is to be used for flow capacity tests for other observations indicated in the following paragraphs.

Not less than two successive start-to-discharge and resealing pressure observations are to be made on each of the three test valves under test No. 1 and 3 of paragraphs 10.1.2. and 10.1.4. below.

10.1.2. Start-to-discharge and resealing pressures of pressure relief valves - test No. 1

10.1.2.1. Before being subjected to a flow capacity test, the start-to-discharge pressure of each of three samples of a pressure relief valve of a specific size, design, and setting shall be within + 3 per cent of the average of the pressures, but the start-to-discharge pressure of any one of the three valves shall be not less than 95 per cent, not more than 105 per cent, of the set pressure marked on the valve.

10.1.2.2. The resealing pressure of a pressure relief valve before being subjected to a flow capacity test shall be not less than 90 per cent of the initially observed start-to-discharge pressure.

10.1.2.3. A pressure relief is to be connected to an air or other aerostatic supply source capable of being maintained at a pressure of at least 500 kPa effective pressure above the marked set pressure of the valve being tested. A positive shut-off valve and a pressure gauge having a pressure range such that the test pressure will be between 1 1/2 and 2 times the maximum scale reading of the gauge, are to be installed in the pressure supply piping. The pressure gauge is to be installed in the piping between the valve being tested and the positive shut-off valve. Start-to-discharge and resealing pressure are to be observed through a water seal not over 100 mm in depth.

10.1.2.4. After recording the start-to-discharge pressure of the valve, the pressure is to be increased sufficiently above the start-to-discharge pressure to ensure unseating of the valve. The shut-off valve is then to be closed tightly and the water seal, as well as the pressure gauge, are to be observed closely. The pressure at which bubbles through the water seal cease is to be recorded as the resealing pressure of the valve.

10.1.3. Flow capacity of pressure relief valves - test No. 2

10.1.3.1. The flow capacity of each of three samples of a pressure relief valve of a specific size, design, and setting shall fall within a range of 10 per cent of the highest observed capacity.

10.1.3.2. During flow capacity tests on each valve, there shall be no evidence of chattering or other abnormal operating condition.

10.1.3.3. The blow-down pressure of each valve shall be not less than 65 per cent of the initially recorded start-to-discharge pressure.

- 10.1.3.4. A flow capacity test on a pressure relief valve is to be conducted at a flow rating pressure of 120 per cent of the maximum set pressure.
- 10.1.3.5. A flow capacity test on a pressure relief valve is to be conducted by utilizing a properly designed and calibrated orifice flowmeter of the flange type connected to a source of air supply of adequate capacity and pressure. Modifications of the flowmeter from that described herein, and an aerostatic flow medium other than air, may be used provided the end results are the same.
- 10.1.3.6. The flowmeter is to be arranged with sufficiently long lengths of pipe both preceding and following the orifice, or other arrangements including straightening vanes, to assure no disturbance at the orifice place for the ratios of orifice to pipe diameters to be employed.

Flanges between which the orifice plate is located and clamped are to be provided with pressure take-off lines connected to a manometer. This instrument indicates the pressure differential across the orifice plate and the reading is used in the flow calculation. A calibrated pressure gauge is to be installed in that portion of the meter pipe downstream of the orifice plate. This gauge indicates the flow pressure and the reading is also used in the flow calculation.

- 10.1.3.7. A temperature-indicating instrument is to be connected to the meter pipe downstream of the orifice plate to indicate the temperature of the air flowing to the safety valve. The reading of this instrument is to be integrated in the calculation to correct the temperature of the air flow to a 15°C base temperature. A barometer is to be available for indicating the prevailing atmospheric pressure.

The reading of the barometer is to be added to the indicated air-flow gauge pressure. This absolute pressure is similarly to be integrated in the flow calculation. The air pressure to the flowmeter is to be controlled by a suitable valve installed in the air-supply piping ahead of the flowmeter. The pressure relief valve under test is to be connected to the discharge end of the flowmeter.

- 10.1.3.8. After all preparations for flow capacity tests have been made, the valve in the air-supply line is to be opened slowly and the pressure to the valve under test is to be increased to the appropriate flow rating pressure. During this interval, the pressure at which the valve "pops" open is to be recorded as the popping pressure.
- 10.1.3.9. The predetermined flow rating pressure is to be maintained constant for a brief interval until the readings of the instruments become

stabilized. Readings of the flow pressure gauge, pressure differential manometer, and the flowing air temperature indicator are to be recorded simultaneously. The pressure is then to be decreased until there is no further discharge from the valve.

The pressure at which this occurs is to be recorded as the blow-down pressure of the valve.

- 10.1.3.10. From the recorded data and the known orifice coefficient of the flowmeter, the air-flow capacity of the pressure relief valve tested is to be calculated using the following formula:

$$Q = \frac{F_b \cdot F_t \cdot \sqrt{0.1 \cdot h \cdot p}}{60}$$

where:

- Q = Flow capacity of pressure relief valve - in m³/min. of air at 100 kPa absolute and 15°C.
- F_b = Basic orifice factor of flowmeter at 100 kPa absolute and 15°C.
- F_t = Flowing air temperature factor to convert recorded temperature to base of 15°C.
- h = Differential pressure across orifice of meter in kPa.
- p = Flowing air pressure to pressure relief valve - in kPa absolute (recorded gauge pressure plus recorded barometric pressure).
- 60 = Denominator to convert equation from m³/hour to m³/min.
- 10.1.3.11. The average flow capacity of the three pressure relief valves rounded off to the nearest five units is to be taken as the flow capacity of the valve of that specific size, design, and setting.
- 10.1.4. **Recheck start-to-discharge and resealing pressures of pressure-relief-valves test No. 3**
- 10.1.4.1. Subsequent to flow capacity tests, the start-to-discharge pressure of a pressure relief valve shall be not less than 85 per cent, and the resealing pressure shall be not less than 80 per cent of the initial start-to-discharge and resealing pressures recorded under test No. 1 of paragraph 10.1.2.

10.1.4.2. These tests are to be conducted approximately 1 hour after the flow capacity test, and the test procedure is to be the same as described under test No. 1 of paragraph 10.1.2.

10.2. **Operation test excess flow valve**

10.2.1. An excess flow valve shall operate at not more than 10 per cent above, nor less than 20 per cent below the rated closing flow capacity specified by the manufacturer, and shall close automatically at a pressure differential across the valve of not more than 100 kPa during the operation tests described below.

10.2.2. Three samples of each size and style of valve are to be subjected to these tests. A valve intended for use only with liquid is to be tested with water, otherwise the tests are to be made both with air and with water. Except as indicated in paragraph 10.2.3., separate tests are to be run with each sample installed in vertical, horizontal and inverted positions. The tests with air to be made without piping or other restriction connected to the outlet of the tests sample.

10.2.3. A valve intended for installation in one position only may be tested only in that position.

10.2.4. The test with air is to be conducted by utilizing a properly designed and calibrated orifice flowmeter of the flange type, connected to a source of air supply of adequate capacity and pressure.

10.2.5. The test sample is to be connected to the outlet of the flowmeter. A manometer or calibrated pressure-gauge reading in increments of not more than 3 kPa is to be installed on the upstream side of the test sample to indicate the closing pressure.

10.2.6. The test is conducted by slowly increasing the flow of air through the flowmeter until the check valve closes. At the instant of closing, the pressure differential across the flowmeter orifice and the closing pressure indicated by the gauge are to be recorded. The rate of flow at closing is then to be calculated.

10.2.7. Other types of flowmeters and a gas, other than air, may be used.

10.2.8. The test with water is to be conducted using a liquid flowmeter (or equivalent) installed in a piping system having sufficient pressure to provide the required flow. The system is to include an inlet piezometer or pipe at least one pipe size larger than the valve to be tested, with a flow control valve connected between the flowmeter and piezometer. A hose or hydrostatic relief valve, or both, may be used to reduce the effect of the pressure shock when the excess flow valve closes.

- 10.2.9. The test sample is to be connected to the outlet end of the piezometer. A manometer or calibrated pressure gauge of the retard type, which will permit readings in the range of 0 to 1,440 kPa is to be connected to a pressure take-off on the upstream side of the test sample to indicate the closing pressure. The connection is to be made using a length of rubber hose between the pressure gauge and the pressure take-off, with a valve installed at the gauge inlet to permit bleeding air from the system.
- 10.2.10. Prior to the test, the flow control valve is to be opened slightly, with the bleed valve at the pressure gauge open, to eliminate air from the system. The bleed valve is then to be closed and the test is conducted by slowly increasing the flow until the check valve closes. During the test the pressure gauge is to be positioned at the same level as the test sample. At the instant of closing, the rate of flow and closing pressure are to be recorded. When the excess flow valve is at cut-off position, the leakage or by-pass rate of flow is to be recorded.
- 10.2.11. An excess flow valve used in the assembly of a filling unit shall close automatically at a pressure differential of not more than 138 kPa when tested as described below.
- 10.2.12. Three samples of each size of valve are to be subjected to these tests. The tests are to be made with air, and separate tests are to be run with each sample mounted vertically and horizontally. The tests are to be conducted as described in paragraphs 8.2.4. to 8.2.7., with a filling unit hose coupling connected to the test sample and with the upper non-return valve held in the open position.
- 10.3. **Charging-speed-test**
- 10.3.1. The good function of the device limiting the filling degree of the container has to be performed by filling speeds of 20, 50 and 80 l/min.
- 10.4. **Endurance-test for the filling limiter**
- The device limiting the filling degree of the container shall be capable of withstanding 6,000 complete filling cycles to the maximum filling degree.
- 10.5. **Vibration test procedure**
- 10.5.1. **Scope**
- Any device limiting the filling degree of the container and operating by a float, after having been subjected to the tests verifying that:

It limits the degree of filling of the container to 80 per cent or less of its capacity;

It does not allow - at the cut-off position - any filling of the container at a rate exceeding 1 litre/minute,

shall be subjected to one of the test procedures laid down in paragraph 10.5.5. or 10.5.6. below to ensure that the device is constructed to withstand expected dynamic vibrational stresses and to ensure that performance degradations or malfunctions will not be produced by the service vibration environment.

10.5.2. **Equipment and mounting techniques**

The test item shall be attached to the vibration equipment by its normal mounting means, either directly to the vibration exciter or transition table, or by means of a rigid fixture capable of transmitting the specified vibration conditions. Equipment used to measure and/or record the acceleration level or amplitude level and the frequency shall have an accuracy of at least 10 per cent of the measured value.

10.5.3. **Choice of procedure**

At the choice of the authority granting type-approval the tests shall be performed according to either procedure A described in paragraph 10.5.5. or procedure B described in paragraph 10.5.6.

10.5.4. **General**

The following tests shall be carried out along each of the three orthogonal axes of the test item.

10.5.5. **Procedure A**

10.5.5.1. **Resonance search**

Resonant frequencies of the filling limiter shall be determined by varying the frequency of applied vibration slowly through the specified range at reduced test levels but with sufficient amplitude to excite the item. Sinusoidal resonance search may be performed using the test level and cycling time specified for the cycling test, provided the resonance search time is included in the required cycling test time of paragraph 10.5.5.3.

10.5.5.2. **Resonance dwell test**

The test item shall be vibrated for 30 minutes along each axis at the most severe resonant frequencies determined in paragraph 10.5.5.1. The test level shall be 1.5 g (14.7 m/sec²). If more than four significant resonant frequencies are found for

any one axis, the four most severe resonant frequencies shall be chosen for this test. If a change in the resonant frequency occurs during the test, its time of occurrence shall be recorded and immediately the frequency shall be adjusted to maintain the peak resonance condition. The final resonant frequency shall be recorded. The total dwell test time shall be included in the required cycling test time of paragraph 10.5.5.3.

10.5.5.3. **Sinusoidal cycling test**

The test item shall be sinusoidally vibrated for three hours along each of its orthogonal axes in accordance with:

an acceleration level of 1.5 g. (14.7 m/sec²),

a frequency range of 5 to 200 Hz,

a sweep time of 12 minutes.

The frequency of applied vibration shall be swept over the specified range logarithmically.

The specified sweep time is that of an ascending plus a descending sweep.

10.5.6. **Procedure B**

10.5.6.1. The test shall be performed on a sinusoidal vibrating bench, at a constant acceleration of 1.5 g and at frequencies ranging between 5 and 200 Hz. The test shall last for 5 hours for each of the axes specified in paragraph 8.5.4. The frequency band 5-200 Hz shall be covered in each of the two senses in 15 minutes.

10.5.6.2. Alternatively, in case the test is not conducted by utilizing a constant acceleration bench, the frequency band from 5 to 200 Hz has to be subdivided in 11 semi-octave bands, each of them covered by a constant amplitude, so that the theoretical acceleration is included between 1 and 2 g (g = 9.8 m/sec²).

Vibration amplitudes for each band are as follows:

Amplitude in mm (crest value)	Frequency in Hz (for acceleration = 1g)	Frequency in Hz (for acceleration = 2g)
10	5	7
5	7	10
2.50	10	14
1.25	14	20
0.60	20	29
0.30	29	41
0.15	41	57
0.08	57	79
0.04	79	111
0.02	111	157
0.01	157	222

Each band shall be covered in both directions in 2 minutes, 30 minutes totally for each band.

10.5.7. **Specification**

After having been subjected to one of the vibration test procedures described above the device shall show no mechanical failures and is deemed to conform to the vibration test requirements only in the case the values of its characteristic parameters:

filling degree at the cut-off position,

filling rate allowed at the cut-off position,

do not exceed the prescribed limits and are not exceeding by more than 10 per cent the values preceding the vibration test procedure.

11. **LPG compatibility tests for synthetic materials**

11.1. A synthetic part in contact with LPG-liquid shall not show excessive volume change or loss of weight.

Resistance to n-pentane according to ISO 1817 with the following conditions:

- (i) medium: n-pentane
- (ii) temperature: 23 °C (tolerance acc.to ISO 1817)
- (iii) immersion period: 72 hours

- 11.2. Requirements:
maximum change in volume 20 %
After storage in air with a temperature of 40°C for a period of 48 hours the mass compared to the original value may not decrease more than 5 %.

12. **Corrosion resistance**

- 12.1. A metal LPG containing component shall comply with the leakage tests mentioned in 4, 5, 6 and 7 and after having been submitted to 144 hours salt spray test according to DIN 50021 or ISO 9227, with all connections closed.

or an optional test

- 12.1.1. A metal LPG containing component shall comply with the leakage tests mentioned in 4, 5, 6 and 7 and after having been submitted to a salt spray test according to IEC 68-2-52 Kb: Salt Spray Fog Test.

Test procedure:

Before the test the component shall be cleaned according to the instructions of the manufacturer. All the connections shall be closed off. The component shall not be operated during the test.

Subsequently the component shall be submitted during 2 hours to spraying with a solution of salt, containing 5% NaCl (mass %) with less than 0.3 % contamination and 95% distilled or demineralised water, at a temperature of 20°C. After the spraying the component is stored at temperature of 40°C and 90-95% relative humidity for 168 hours. This sequence shall be repeated 4 times.

After the test the component shall be cleaned and dried during 1 hour at 55°C. The component shall now be conditioned to reference conditions during 4 hours, before submitting it to further testing.

- 12.2. A copper or brass LPG containing component shall comply with the leakage tests mentioned in 4, 5, 6 and 7 and after having been submitted to 24 hours immersion in Ammonia according to DIN 50916 or ISO 6957 with all connections closed.

13. **Resistance to dry-heat**

The test has to be done in compliance with ISO 188. The test piece has to be exposed to air at a temperature equal to the maximum operating temperature for 168 hours.

The allowable change in tensile strength should not exceed + 25 %. The allowable change in ultimate elongation shall not exceed the following values:

Maximum increase 10 %
Maximum decrease 30 %

14. **Ozone ageing**

14.1. The test has to be in compliance with ISO 1431/1.

The test piece, which has to be stressed to 20 % elongation shall be exposed to air at 40°C with an ozone concentration of 50 parts per hundred million during 120 hours.

14.2. No cracking of the test piece is allowed.

15. **Creep**

A non metallic part containing liquid LPG shall comply with the leakage tests mentioned in paragraphs 3, 4 and 5 after having been submitted to a hydraulic pressure of 2.25 times the maximum operating pressure at a temperature of 120°C during minimal 96 hours. Water or any other suitable hydraulic fluid may be used as a test medium.

16. **Temperature cycle test**

A non metallic part containing liquid LPG shall comply with the leakage tests mentioned in 3, 4 and 5 after having been submitted to a 96 hours temperature cycle from the minimum operating temperature up to the maximum operating temperature with a cycle time of 120 minutes, under maximum working pressure.

Annex 16

PROVISIONS REGARDING LPG IDENTIFICATION MARK FOR BUSES



The sign consists of a sticker which must be weather resistant.

The colour and dimensions of the sticker must fulfil the following requirements:

Colours:

Background	: green
Border	: white or white reflecting
Letters	: white or white reflecting

Dimensions

Border width	: 4 - 6 mm
Character height	: \geq 25 mm
Character thickness	: \geq 4 mm
Sticker width	: 110 - 150 mm
Sticker height	: 80 - 110 mm

The word "LPG" must be centred in the middle of the sticker.

Annex 17

PROVISIONS REGARDING IDENTIFICATION MARK FOR SERVICE VALVE

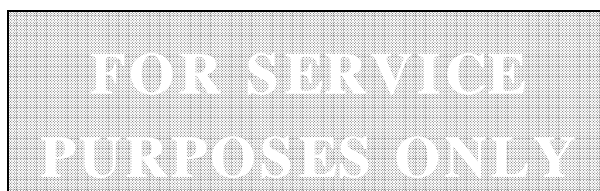

The sign consists of a sticker which must be weather resistant.

The colour and dimensions of the sticker must fulfil the following requirements:

Colours:

Background : red
Letters : white or white reflecting

Dimensions

Character height : ≥ 5 mm
Character thickness : ≥ 1 mm
Sticker width : 70 - 90 mm
Sticker height : 20 - 30 mm

The text "FOR SERVICE PURPOSES ONLY" must be centred in the middle of the sticker.

_____ "