

29 March 2007

AGREEMENT

CONCERNING THE ADOPTION OF UNIFORM TECHNICAL PRESCRIPTIONS FOR WHEELED VEHICLES, EQUIPMENT AND PARTS WHICH CAN BE FITTED AND/OR BE USED ON WHEELED VEHICLES AND THE CONDITIONS FOR RECIPROCAL RECOGNITION OF APPROVALS GRANTED ON THE BASIS OF THESE PRESCRIPTIONS */

(Revision 2, including the amendments which entered into force on 16 October 1995)

Addendum 29: Regulation No. 30

Revision 3

Incorporating all valid text up to:

Supplement 10 to the 02 series of amendments - Date of entry into force: 13 January 2000

Corrigendum 1 to Supplement 10 to the 02 series of amendments, subject of Depository

Notification C.N.443.2004.TREATIES-1 dated 13 May 2004

Supplement 11 to the 02 series of amendments - Date of entry into force: 28 December 2000

Supplement 12 to the 02 series of amendments - Date of entry into force: 20 February 2002**/

Corrigendum 1 to Supplement 12 to the 02 series of amendments, subject of Depository

Notification C.N.791.2002.TREATIES-1 dated 1 August 2002 (English and Russian only)

Supplement 13 to the 02 series of amendments - Date of entry into force: 26 February 2004

Supplement 14 to the 02 series of amendments - Date of entry into force: 18 January 2006

UNIFORM PROVISIONS CONCERNING THE APPROVAL OF PNEUMATIC TYRES FOR MOTOR VEHICLES AND THEIR TRAILERS



UNITED NATIONS

*/ Former title of the Agreement:

Agreement Concerning the Adoption of Uniform Conditions of Approval and Reciprocal Recognition of Approval for Motor Vehicle Equipment and Parts, done at Geneva on 20 March 1958.

**/ For New Zealand, the entry into force is 20 April 2002.

Regulation No. 30

UNIFORM PROVISIONS CONCERNING THE APPROVAL OF PNEUMATIC
TYRES FOR MOTOR VEHICLES AND THEIR TRAILERS

CONTENTS

REGULATION	<u>Page</u>
1. Scope.....	5
2. Definitions	5
3. Markings	12
4. Application for approval.....	14
5. Approval	15
6. Requirements	16
7. Modifications of the type of pneumatic tyre and extension of approval.....	21
8. Conformity of production	21
9. Penalties for non-conformity of production	21
10. Production definitively discontinued.....	22
11. Transitional provisions	22
12. Names and addresses of Technical Services responsible for conducting approval tests and of Administrative Departments	22

ANNEXES

Annex 1 - Communication concerning the approval or extension or refusal or withdrawal of approval or production definitively discontinued of a type of pneumatic tyre for motor vehicles pursuant to Regulation No. 30

Annex 2 - Example of the arrangement of the approval mark

Annex 3 - Arrangement of tyre markings

Annex 4 - Load-capacity indices

CONTENTS (continued)

Annex 5 - Tyre size designation and dimensions

Annex 6 - Method of measuring pneumatic tyres

Annex 7 - Procedure for load/speed performance tests

1. SCOPE

This Regulation covers new pneumatic tyres designed primarily, but not only, for vehicles in categories M₁, O₁ and O₂. ^{1/}

It does not apply to tyres designed for

- (a) the equipment for vintage cars
- (b) competitions.

2. DEFINITIONS

For the purposes of this Regulation,

2.1. "Type of pneumatic tyre" means a category of pneumatic tyres which do not differ in such essential respects as:

2.1.1. The manufacturer;

2.1.2. Tyre-size designation;

2.1.3. Category of use (ordinary (road-type) or snow tyre or for temporary use);

2.1.4. Structure (diagonal (bias-ply), bias-belted, radial-ply, run flat tyre);

2.1.5. Speed category symbol;

2.1.6. Load-capacity index;

2.1.7. Tyre cross-section;

2.2. "Snow tyre" means a tyre whose tread pattern and whose structure are primarily designed to ensure in mud and fresh or melting snow a performance better than that of an ordinary (road-type) tyre. The tread pattern of a snow tyre generally consists of groove (rib) and/or solid-block elements more widely spaced than on an ordinary (road-type) tyre;

2.3. "Structure" of a pneumatic tyre means the technical characteristics of the tyre's carcass. The following structures are distinguished in particular;

^{1/} As defined in Annex 7 to the Consolidated Resolution on the Construction of Vehicles (R.E.3), (document TRANS/WP.29/78/Rev.1/Amend.2 as last amended by Amend.4).

- 2.3.1. "Diagonal" or "bias-ply" describes a pneumatic-tyre structure in which the ply cords extend to the beads and are laid at alternate angles of substantially less than 90° to the centre line of the tread;
- 2.3.2. "Bias-belted" describes a pneumatic-tyre structure of diagonal (bias-ply) type in which the carcass is restricted by a belt comprising two or more layers of substantially inextensible cord material laid at alternate angles close to those of the carcass;
- 2.3.3. "Radial" describes a pneumatic-tyre structure in which the ply cords extend to the beads and are laid substantially at 90° to the centre line of the tread, the carcass being stabilized by an essentially inextensible circumferential belt;
- 2.3.4. "Reinforced" or "Extra Load" describes a pneumatic-tyre structure in which the carcass is more resistant than that of the corresponding standard tyre;
- 2.3.5. "Temporary use spare tyre" means a tyre different from a tyre intended to be fitted to any vehicle for normal driving conditions but intended only for temporary use under restricted driving conditions;
- 2.3.6. "T-type temporary use spare tyre" means a type of temporary use spare tyre designed for use at inflation pressures higher than those established for standard and reinforced tyres;
- 2.3.7. "Run flat tyre" or "Self supporting tyre" describes a pneumatic tyre structure provided with any technical solutions (for example, reinforced sidewalls, etc.) allowing the pneumatic tyre, mounted on the appropriate wheel and in the absence of any supplementary component, to supply the vehicle with the basic tyre functions, at least, at a speed of 80km/h (50mph) and a distance of 80km when operating in flat tyre running mode.
- 2.4. "Bead" means the part of a pneumatic tyre which is of such shape and structure as to fit the rim and hold the tyre on it; 2/
- 2.5. "Cord" means the strands forming the fabric of the plies in the pneumatic tyre; 2/
- 2.6. "Ply" means a layer of rubber-coated parallel cords; 2/
- 2.7. "Carcass" means that part of a pneumatic tyre other than the tread and the rubber side walls which, when inflated, bears the load; 2/
- 2.8. "Tread" means that part of a pneumatic tyre which comes into contact with the ground; 2/

2/ See explanatory figure.

- 2.9. "Side wall" means the part of a pneumatic tyre between the tread and the bead; 2/
- 2.10. "Lower area of tyre" means the area included between the point of maximum section width of the tyre and the area designed to be covered by the edge of the rim; 2/
- 2.10.1. However, in case of tyres identified by the "tyre to rim fitment configuration" (see para. 3.1.10.) symbol "A", it means the area of the tyre which is seating on the rim.
- 2.11. "Tread groove" means the space between two adjacent ribs or blocks in the tread pattern; 2/
- 2.12. "Section width" means the linear distance between the outsides of the side walls of an inflated pneumatic tyre, excluding elevations due to labelling (marking), decoration or protective bands or ribs; 2/
- 2.13. "Overall width" means the linear distance between the outsides of the side walls of an inflated pneumatic tyre, including labelling (marking), decoration and protective bands or ribs; 2/
- 2.14. "Section height" means a distance equal to half the difference between the outer diameter of the tyre and the nominal rim diameter; 2/
- 2.15. "Nominal aspect ratio (Ra)" means the centuple of the number obtained by dividing the number expressing the section height in mm by the number expressing the nominal section width in mm;
- 2.16. "Outer diameter" means the overall diameter of an inflated new pneumatic tyre; 2/
- 2.17. "Tyre-size designation" is
- 2.17.1. a designation showing:
- 2.17.1.1. the nominal section width. This width must be expressed in mm, except in the case of the types of tyre for which the size designation is shown in the first column of the tables in Annex 5 to this Regulation;
- 2.17.1.2. the nominal aspect ratio except in the case of certain types of tyre, for which the size designation is shown in the first column of the tables in Annex 5 to this Regulation, or, depending on the tyre design type, the nominal outer diameter expressed in mm;

2/ See explanatory figure.

- 2.17.1.3. a conventional number denoting the nominal rim diameter and corresponding to its diameter expressed either by codes (numbers below 100) or in millimetres (numbers above 100);
- 2.17.1.4. the letter "T" in front of the nominal section width in case of T-type temporary use spare tyres;
- 2.17.1.5. an indication of the tyre to rim fitment configuration when it differs from the standard configuration.
- 2.18. "Nominal rim diameter" means the diameter of the rim on which a tyre is designed to be mounted;
- 2.19. "Rim" means the support for a tyre-and-tube assembly, or for a tubeless tyre, on which the tyre beads are seated; 2/
- 2.19.1. "Tyre to rim fitment configuration" means the type of rim to which the tyre is designed to be fitted. In the case of non-standard rims this will be identified by a symbol applied to the tyre, for example, "CT", "TR", "TD" or "A".
- 2.20. "Theoretical rim" means the notional rim whose width would be equal to x times the nominal section width of a tyre. The value of x shall be specified by the manufacturer of that tyre;
- 2.21. "Measuring rim" means the rim on which a tyre is required to be fitted for size measurements;
- 2.22. "Test rim" means the rim on which a tyre is required to be fitted for testing;
- 2.23. "Chunking" means the breaking away of pieces of rubber from the tread;
- 2.24. "Cord separation" means the parting of the cords from their rubber coating;
- 2.25. "Ply separation" means the parting of adjacent plies;
- 2.26. "Tread separation" means the pulling away of the tread from the carcass;
- 2.27. "Tread-wear indicators" means the projections within the tread grooves designed to give a visual indication of the degree of wear of the tread;

2/ See explanatory figure.

2.28. "Load-capacity index" means a number associated to the reference mass a tyre can carry when operated in conformity with requirements governing utilization specified by the manufacturer.

2.29. "Speed category" means the maximum speed which the tyre can sustain, expressed by speed category symbol (see table below).

2.29.1. The categories of speed are those indicated in the table below:

Speed-category symbol	Maximum speed (km/h)
L	120
M	130
N	140
P	150
Q	160
R	170
S	180
T	190
U	200
H	210
V	240
W	270
Y	300

2.30. Tread pattern grooves

2.30.1. "Principal grooves" means the wide grooves positioned in the central zone of the tyre tread, which have the tread-wear indicators (see para. 2.27.) located inside them.

2.30.2. "Secondary grooves" means the supplementary grooves of the tread pattern which may disappear in the course of the tyre's life.

2.31. "Maximum load rating" means the maximum mass the tyre is rated to carry;

2.31.1. for speed not exceeding 210 km/h the maximum load rating shall not exceed the value associated with the load capacity index of the tyre;

2.31.2. for speed higher than 210 km/h, but not exceeding 240 km/h, (tyres classified with speed category symbol "V") the maximum load rating shall not exceed the

percentage of the value associated with the load capacity index of the tyre, indicated in the table below, with reference to the speed capability of the car to which the tyre is fitted.

Maximum speed (km/h)	Maximum load rating (per cent)
215	98.5
220	97
225	95.5
230	94
235	92.5
240	91

For intermediate maximum speeds linear interpolations of the maximum load rating are allowed.

- 2.31.3. For speeds higher than 240 km/h (tyres classified with speed category symbol "W") the maximum load rating shall not exceed the percentage of the value associated with the load capacity index of the tyre, indicated in the table below, with reference to the speed capability of the car to which the tyre is fitted.

Maximum speed (km/h)	Maximum load rating (per cent)
240	100
250	95
260	90
270	85

For intermediate maximum speeds linear interpolations of the maximum load rating are allowed.

- 2.31.4. For speeds higher than 270 km/h (tyres classified with speed-category symbol "Y") the maximum load rating shall not exceed the percentage of the value associated with the load capacity index of the tyre, indicated in the table below, with reference to the speed capability of the car to which the tyre is fitted.

Maximum speed (km/h)	Maximum load rating (per cent)
-------------------------	-----------------------------------

270	100
280	95
290	90
300	85

For intermediate maximum speeds linear interpolations of the maximum load rating are allowed.

- 2.31.5. For speeds lower or equal to 60 km/h the maximum load rating must not exceed the percentage of mass, associated with the load capacity index of the tyre indicated in the table below with reference to the maximum design speed of the vehicle to which the tyre is to be fitted.

Maximum speed (km/h)	Maximum load rating (per cent)
25	142
30	135
40	125
50	115
60	110

- 2.31.6. For speeds in excess of 300 km/h, the maximum load rating must not exceed the mass specified by the tyre manufacturer with reference to the speed capacity of the tyre. For intermediate speeds between 300 km/h and the maximum speed permitted by the tyre manufacturer, a linear interpolation of the maximum load rating applies.
- 2.32. "Flat tyre running mode" describes the state of the tyre, essentially maintaining its structural integrity, while operating at an inflation pressure between 0 and 70 kPa.
- 2.33. "Basic tyre functions" means the normal capability of an inflated tyre in supporting a given load up to a given speed and transmitting the driving, the steering and the braking forces to the ground on which it runs.
- 2.34. "Run flat system" or "Extended mobility system" describes an assembly of specified functionally dependant components, including a tyre, which together provide the specified performance granting the vehicle with the basic tyre functions, at least, at a speed of 80 km/h (50 mph) and a distance of 80 km when operating in flat tyre running mode.
- 2.35. "Deflected section height" is the difference between the deflected radius, measured from the centre of the rim to the surface of the drum, and one half the nominal rim diameter as defined in ISO 4000-1.

3. MARKINGS

- 3.1. Pneumatic tyres submitted for approval shall bear on both side walls in the case of symmetrical tyres and at least on the outer side wall in the case of asymmetrical tyres:
- 3.1.1. The trade name or mark;
- 3.1.2. The tyre-size designation as defined in paragraph 2.17. of this Regulation;
- 3.1.3. An indication of the structure as follows:
- 3.1.3.1. on diagonal (bias-ply) tyres, no marking or the letter "D" placed in front of the rim diameter marking;
- 3.1.3.2. on radial-ply tyres, the letter "R" placed in front of the rim-diameter marking, and, optionally, the word "RADIAL";
- 3.1.3.3. on bias-belted tyres, the letter "B" placed in front of the rim-diameter marking, and in addition the words "BIAS-BELTED";
- 3.1.3.4. on radial ply tyres suitable for speeds in excess of 240 km/h but not exceeding 300 km/h (tyres marked with the speed symbol "W" or "Y" as part of the service description), the letter "R", placed before the rim diameter code marking, may be replaced with the inscription "ZR".
- 3.1.3.5. on "run flat" or "self supporting" tyres the letter "F" placed in front of the rim diameter marking.
- 3.1.4. An indication of the tyre's speed category by means of the symbol shown in paragraph 2.29. above;
- 3.1.4.1. On tyres suitable for speeds in excess of 300 km/h, the letter "R" placed in front of the rim diameter code marking shall be replaced by the inscription "ZR" and the tyre shall be marked with a service description consisting of the speed symbol "Y" and the corresponding load index. The service description shall be marked within brackets, for example, "(95Y)".
- 3.1.5. The inscription M+S or M.S or M&S in the case of a snow tyre;
- 3.1.6. The load-capacity index as defined in paragraph 2.28. of this Regulation;
- 3.1.7. The word "TUBELESS" if the tyre is designed for use without an inner tube;

- 3.1.8. The word "REINFORCED" or the words "EXTRA LOAD" if the tyre is a reinforced tyre;
- 3.1.9. The date of manufacture in the form of a group of four digits, the first two showing the week and the last two the year of manufacture. However, this marking which may be placed on one side wall only, shall not be mandatory, on any tyre submitted for approval, until two years after the date of entry into force of this Regulation. 3/
- 3.1.10. In the case of tyres first approved after the entry into force of Supplement 13 to the 02 series of amendments to Regulation No. 30, the identification referred to in paragraph 2.17.1.5. shall be placed immediately after the rim diameter marking referred to in paragraph 2.17.1.3.
- 3.1.11. In the case of temporary use spare tyres, the words "TEMPORARY USE ONLY" in upper case characters at least 12.7 mm high.
- 3.1.11.1. In addition, in the case of "T" type temporary use spare tyres, the legend "INFLATE TO 420 kPa (60 psi)", the upper case characters being at least 12.7 mm high.
- 3.1.12. The symbol below if the tyre is a "run flat" or "self supporting" tyre, where "h" is at least 12 mm.

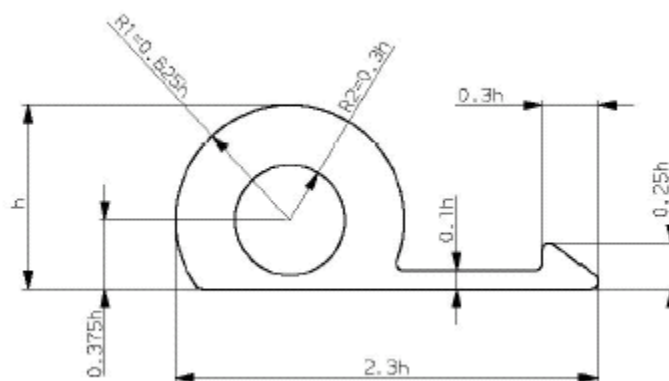

- 3.2. Tyres shall provide adequate space for the approval mark, as shown in Annex 2 to this Regulation.
- 3.3. Annex 3 to this Regulation gives an example of the arrangement of the tyre markings.

3/ Before 1 January 2000, the date of manufacture may be indicated by a group of three digits, the first two showing the week and the last one the year of manufacture.

3.4. The markings referred to in paragraph 3.1. and the approval mark prescribed in paragraph 5.4. of this Regulation shall be moulded on to or into the tyres. They shall be clearly legible and situated in the lower area of the tyre on at least one of its side walls, except for the inscription mentioned in paragraph 3.1.1. above.

3.4.1. However, for tyres identified by the "tyre to rim fitment configuration" (see para. 3.1.10.) symbol "A", the markings may be placed anywhere on the outside sidewall of the tyre.

4. APPLICATION FOR APPROVAL

4.1. The application for approval of a type of pneumatic tyre shall be submitted by the holder of the trade name or mark or by his duly accredited representative. It shall specify:

4.1.1. The tyre-size designation as defined in paragraph 2.17. of this Regulation;

4.1.2. The trade name or mark;

4.1.3. The category of use (ordinary (road-type) or snow-tyre, or for temporary use);

4.1.4. Structure: diagonal (bias ply), bias belted, radial, run flat tyre;

4.1.5. The speed category;

4.1.6. The load-capacity index of the tyre;

4.1.7. Whether the tyre is to be used with or without an inner tube;

4.1.8. Whether the tyre is "standard" or "reinforced" or "T-type temporary use spare tyre";

4.1.9. The ply-rating number of diagonal (bias-ply) tyres;

4.1.10. The overall dimensions: overall section width and outer diameter;

4.1.11. The rims on which the tyre can be mounted;

4.1.12. The measuring rim and test rim;

4.1.13. The test pressure where the manufacturer requests the application of Annex 7, paragraph 1.3. to this Regulation;

4.1.14. The factor x referred to in paragraph 2.20. above.

- 4.1.15. For tyres suitable for speeds in excess of 300 km/h, the maximum speed permitted by the tyre manufacturer and the load carrying capacity allowed for that maximum speed. The tyre manufacturer must also specify these values in the technical literature for the tyre type.
- 4.1.16. The identification of the bead retention rim contours specific for the "flat tyre running mode" of "run flat tyres".
- 4.2. The application for approval shall be accompanied (all in triplicate) by a sketch, or a representative photograph, which identify the tyre tread pattern and a sketch of the envelope of the inflated tyre mounted on the measuring rim, showing the relevant dimensions (see paragraphs 6.1.1. and 6.1.2.) of the type submitted for approval. It shall also be accompanied either by the test report issued by the approved Test Laboratory or by one or two samples of the tyre type, at the discretion of the Competent Authority. Drawings or photographs of the side wall and tread of the tyre shall be submitted once production has been established, no later than one year after the date of issue of the type approval.
- 4.3. The Competent Authority shall verify the existence of satisfactory arrangements for ensuring effective control of the conformity of production before type approval is granted.
- 4.4. Where a tyre manufacturer submits application for type approval for a range of tyres, it is not considered necessary to carry out a load/speed test on every type of tyre in the range. Worst case selection may be made at the discretion of the Approval Authority.
5. APPROVAL
- 5.1. If the pneumatic tyre submitted for approval in pursuance of this Regulation meets the requirements of paragraph 6 below, approval of that type of tyre shall be granted.
- 5.2. An approval number shall be assigned to each type approved. Its first two digits (at present 02) shall indicate the series of amendments incorporating the most recent major technical amendments made to the Regulation at the time of issue of the approval. The same Contracting Party shall not assign the same number to another tyre type covered by this Regulation.
- 5.3. Notice of approval or of extension or refusal or withdrawal of approval or production definitively discontinued of a type of pneumatic tyre pursuant to this Regulation shall be communicated to the Parties to the 1958 Agreement applying this Regulation, by means of a form conforming to the model in Annex 1 to this Regulation.
- 5.3.1. Where type approval is granted for a tyre type suitable for speeds over 300 km/h (see paragraph 4.1.15.), the relevant maximum speed (km/h) and the load carrying

capacity (kg) allowed for the maximum speed shall be notified in clear in section 10 of the communication form (see Annex 1 of this Regulation); load carrying capacities for intermediate speeds higher than 300 km/h may also be specified.

5.4. There shall be affixed conspicuously to every pneumatic tyre conforming to a type of tyre approved under this Regulation, in the space referred to in paragraph 3.2. above and in addition to the markings prescribed in paragraph 3.1. above, an international approval mark consisting of:

5.4.1. A circle surrounding the letter "E" followed by the distinguishing number of the country which has granted approval; 4/

5.4.2. An approval number.

5.5. The approval mark shall be clearly legible and be indelible.

5.6. Annex 2 to this Regulation gives an example of the arrangement of the approval mark.

6. REQUIREMENTS

6.1. Dimensions of tyres

6.1.1. Section width of a tyre

6.1.1.1. The section width shall be calculated by the following formula:

4/ 1 for Germany, 2 for France, 3 for Italy, 4 for the Netherlands, 5 for Sweden, 6 for Belgium, 7 for Hungary, 8 for the Czech Republic, 9 for Spain, 10 for Serbia, 11 for the United Kingdom, 12 for Austria, 13 for Luxembourg, 14 for Switzerland, 15 (vacant), 16 for Norway, 17 for Finland, 18 for Denmark, 19 for Romania, 20 for Poland, 21 for Portugal, 22 for the Russian Federation, 23 for Greece, 24 for Ireland, 25 for Croatia, 26 for Slovenia, 27 for Slovakia, 28 for Belarus, 29 for Estonia, 30 (vacant), 31 for Bosnia and Herzegovina, 32 for Latvia, 33 (vacant), 34 for Bulgaria, 35 (vacant), 36 for Lithuania, 37 for Turkey, 38 (vacant), 39 for Azerbaijan, 40 for The former Yugoslav Republic of Macedonia, 41 (vacant), 42 for the European Community (Approvals are granted by its Member States using their respective ECE symbol), 43 for Japan, 44 (vacant), 45 for Australia, 46 for Ukraine, 47 for South Africa, 48 for New Zealand, 49 for Cyprus, 50 for Malta, 51 for the Republic of Korea, 52 for Malaysia, 53 for Thailand, 54 and 55 (vacant) and 56 for Montenegro. Subsequent numbers shall be assigned to other countries in the chronological order in which they ratify or accede to the Agreement Concerning the Adoption of Uniform Technical Prescriptions for Wheeled Vehicles, Equipment and Parts which can be Fitted and/or be Used on Wheeled Vehicles and the Conditions for Reciprocal Recognition of Approvals Granted on the Basis of these Prescriptions, and the numbers thus assigned shall be communicated by the Secretary-General of the United Nations to the Contracting Parties to the Agreement.

$$S = S_1 + K(A - A_1),$$

where:

S is the "section width" expressed in mm and measured on the measuring rim;

S₁ is the "nominal section width" (in mm) as shown on the side wall of the tyre in the designation of the tyre as prescribed;

A is the width (expressed in mm) of the measuring rim, as shown by the manufacturer in the descriptive note; 5/

A₁ is the width (expressed in mm) of the theoretical rim.

A₁ shall be taken to equal S₁ multiplied by the factor x, as specified by the manufacturer, and K shall be taken to equal 0.4.

6.1.1.2. However, for the types of tyres for which the designation is given in the first column of the tables in Annex 5 to this Regulation, the section width shall be that given opposite the tyre designation in these tables.

6.1.1.3. However, for tyres identified by the "tyre to rim fitment configuration" (see para. 3.1.10.) symbol "A", K shall be taken equal to 0.6.

6.1.2. Outer diameter of a tyre

6.1.2.1. The outer diameter of a tyre shall be calculated by the following formula:

$$D = d + 2H$$

where:

D is the outer diameter expressed in mm

d is the conventional number defined in paragraph 2.17.1.3. above, expressed in mm, 5/

H is the nominal section height in mm, equal to:

$$H = 0.01S_1.R_a,$$

S₁ is the nominal section width in mm, and

5/ When the conventional number is given by codes, the value in mm is obtained by multiplying such number by 25.4.

Ra is the nominal aspect ratio,

all as shown on the side wall of the tyre in the tyre-size designation in conformity with the requirements of paragraph 3.4. above.

6.1.2.2. However, for the types of tyres for which the designation is given in the first column of the tables of Annex 5 to this Regulation the outer diameter shall be that given opposite the "size" designation in these tables.

6.1.2.3. However, for tyres identified by the "tyre to rim fitment configuration" (see para. 3.1.10.) symbol "A", the outer diameter shall be that specified in the tyre size designation as shown on the sidewall of the tyre.

6.1.3. Method of measuring pneumatic tyres

The dimensions of pneumatic tyres shall be measured by the procedure described in Annex 6 to this Regulation.

6.1.4. Tyre section-width specifications

6.1.4.1. The overall width of a tyre may be less than the section width determined pursuant to paragraph 6.1.1. above.

6.1.4.2. It may exceed that value by the following percentages:

6.1.4.2.1. in diagonal (bias-ply) tyres: 6 per cent;

6.1.4.2.2. in radial ply, run flat tyres: 4 per cent;

6.1.4.2.3. in addition, if the tyre has special protective ribs (or bands), the figure as increased by the above tolerance may be exceeded by 8 mm.

6.1.4.2.4. However, for tyres identified by the "tyre to rim fitment configuration" (see para. 3.1.10.) symbol "A", the overall width of the tyre, in the lower area of the tyre, equals the nominal width of the rim on which the tyre is mounted, as shown by the manufacturer in the descriptive note, increased by 20 mm.

6.1.5. Tyre outer-diameter specifications

The outer-diameter of a tyre must not be outside the values Dmin and Dmax obtained from the following formulae:

$$D_{min} = d + (2H \cdot a)$$

$$D_{max} = d + (2H \cdot b)$$

where:

6.1.5.1. for sizes listed in Annex 5, and for tyres identified by the "tyre to rim fitment configuration" (see para. 3.1.10.) symbol "A", the nominal section height H is equal to:

$$H = 0.5 (D-d), \text{ for references see paragraph 6.1.2.}$$

6.1.5.2. for other sizes, not listed in Annex 5, "H" and "d" are as defined in paragraph 6.1.2.1,

6.1.5.3. Coefficients "a" and "b" are respectively:

6.1.5.3.1. Coefficient "a" = 0.97

6.1.5.3.2.	Coefficient "b" for ordinary (road type) tyres	<u>Radial, Run flat tyre</u> 1.04	<u>Diagonal and Bias Belted</u> 1.08
------------	--	--	---

6.1.5.4. for snow tyres the overall diameter (Dmax) established in conformity with the above may be exceeded by 1 per cent.

6.2. Load/speed performance test

6.2.1. The pneumatic tyre shall undergo a load/speed performance test carried out by the procedure described in Annex 7 to this Regulation.

6.2.1.1. Where application is made for tyres identified by means of letter code "ZR" within the size designation and suitable for speeds over 300 km/h (see paragraph 4.1.15.), the above load/speed test is carried out on one tyre at the load and speed conditions marked on the tyre (see paragraph 3.1.4.1.). Another load/speed test must be carried out on a second sample of the same tyre type at the load and speed conditions specified as maximum by the tyre manufacturer (see paragraph 4.1.15. of this Regulation).

The second test may be carried out on the same tyre sample if the tyre manufacturer agrees.

6.2.1.2. Where application is made for the type approval of a "run flat system" the above load speed test is carried out on one tyre, inflated as per paragraph 1.2. of Annex 7, at the load and speed conditions marked on the tyre (see paragraph 3.1.4.1.). Another load/speed test must be carried out on a second sample of the same tyre type as specified in paragraph 3. of Annex 7. The second test may be carried out on the same sample if the manufacturer agrees.

6.2.2. A tyre which after undergoing the load/speed test does not exhibit any tread separation, ply separation, cord separation, chunking or broken cords shall be deemed to have passed the test.

6.2.2.1. However, a tyre marked with the speed symbol "Y" which, after undergoing the relevant test, exhibits superficial blistering of the tyre tread caused by the specific test equipment and conditions, is deemed to have passed the test.

6.2.2.2. If a "run flat system" tyre which, after undergoing the test as specified in paragraph 3. of Annex 7, does not exhibit a change in the deflected section height, compared to the deflected section height at the start of the test, higher than 20 per cent and retains the tread connected to the two sidewalls, it is deemed to have passed the test.

6.2.3. The outer diameter of the tyre, measured six hours after the load/speed performance test, must not differ by more than ± 3.5 per cent from the outer diameter as measured before the test.

6.3. Tread-wear indicators

6.3.1. The pneumatic tyre shall include not less than six transverse rows of wear indicators, approximately equally spaced and situated in the principal grooves of the tread. The tread-wear indicators shall be such that they cannot be confused with the rubber ridges between the ribs or blocks of the tread.

6.3.2. However, in the case of tyres of dimensions appropriate for mounting on rims of a nominal diameter of 12 or less, four rows of tread-wear indicators shall be accepted.

6.3.3. The tread-wear indicators must provide a means of indicating, with a tolerance of $+0.60/-0.00$ mm, when the tread grooves are no longer more than 1.6 mm deep.

6.3.4. The height of tread-wear indicators is determined by measuring the difference between the depth, from the tread's surface, to the top of the tread-wear indicator and to the bottom of the tread groove close to the slope at the base of the tread-wear indicator.

7. MODIFICATIONS OF THE TYPE OF PNEUMATIC TYRE AND EXTENSION OF APPROVAL

7.1. Every modification of the type of pneumatic tyre shall be notified to the Administrative Department which approved the type of pneumatic tyre. The department may then either:

- 7.1.1. Consider that the modifications made are unlikely to have an appreciable adverse effect and that in any case, the pneumatic tyre still complies with the requirements; or
- 7.1.2. Require a further test report from the Technical Service responsible for conducting the tests.
- 7.2. A modification of the tread pattern of the tyre shall not be considered to necessitate a repetition of the tests prescribed in paragraph 6. of this Regulation.
- 7.3. Confirmation or refusal of approval, specifying the alterations, shall be communicated by the procedure specified in paragraph 5.3. above to the Parties to the Agreement which apply this Regulation.
- 7.4. The Competent Authority issuing the extension of approval shall assign a series number for such an extension and inform thereof the other Parties to the 1958 Agreement applying this Regulation by means of a communication form conforming to the model in Annex 1 to this Regulation.

8. CONFORMITY OF PRODUCTION

The conformity of production procedures shall comply with those set out in the Agreement, Appendix 2 (E/ECE/324-E/ECE/TRANS/505/Rev.2), with the following requirements:

- 8.1. Tyres approved under this Regulation shall be so manufactured as to conform to the type approved, by meeting the requirements set forth in paragraph 6. above.
- 8.2. The authority which has granted type approval may at any time verify the conformity control methods applied in each production facility. For each production facility, the normal frequency of these verifications shall be at least once every two years.

9. PENALTIES FOR NON-CONFORMITY OF PRODUCTION

- 9.1. The approval granted in respect of a type of pneumatic tyre pursuant to this Regulation may be withdrawn if the requirements laid down in paragraph 8.1. above are not complied with or if the tyres taken from the series have failed to pass the tests prescribed in that paragraph.
- 9.2. If a Contracting Party to the Agreement applying this Regulation withdraws an approval it has previously granted, it shall forthwith so notify the other Contracting Parties applying this Regulation by means of a communication form conforming to the model in Annex 1 to this Regulation.

10. PRODUCTION DEFINITELY DISCONTINUED

If the holder of an approval completely ceases to manufacture a type of pneumatic tyre approved in accordance with this Regulation, he shall so inform the authority which granted the approval. Upon receiving the relevant communication that authority shall inform thereof the other Parties to the 1958 Agreement applying this Regulation by means of a communication form conforming to the model in Annex 1 to this Regulation.

11. TRANSITIONAL PROVISIONS

11.1. Contracting Parties applying this Regulation shall not refuse to grant extensions of approval to preceding series of amendments, or supplement to series of amendments to this Regulation.

11.2. No Contracting Parties applying this Regulation shall refuse a tyre approved to the 01 series of amendments to this Regulation.

11.3. Tread-wear indicators:

11.3.1. As from the date of entry into force of Supplement 4 to the 02 series of amendments, Contracting Parties applying this Regulation may no longer issue approvals pursuant to Supplement 3 to the 02 series of amendments with respect to the requirements of paragraph 6.3.3.

11.3.2. All new tyres manufactured from 1 October 1995 shall conform to the requirements of paragraph 6.3.3. as amended by Supplement 4 to the 02 series of amendments.

12. NAMES AND ADDRESSES OF TECHNICAL SERVICES RESPONSIBLE FOR CONDUCTING APPROVAL TESTS AND OF ADMINISTRATIVE DEPARTMENTS

12.1. The Parties to the 1958 Agreement which apply this Regulation shall communicate to the United Nations Secretariat the names and addresses of the Technical Services responsible for conducting approval tests and of the Administrative Departments which grant approval and to which forms certifying approval, or extension, or refusal or withdrawal of approval or production definitively discontinued, issued in other countries, are to be sent.

12.2. The Parties to the Agreement which apply this Regulation may designate laboratories of tyre manufacturers as approved test laboratories.

12.3. Where a Party to the Agreement applies paragraph 12.2. above, it may, if it so desires, be represented at the tests by one or more persons of its choice.

Explanatory figure
(see paragraph 2 of the Regulation)

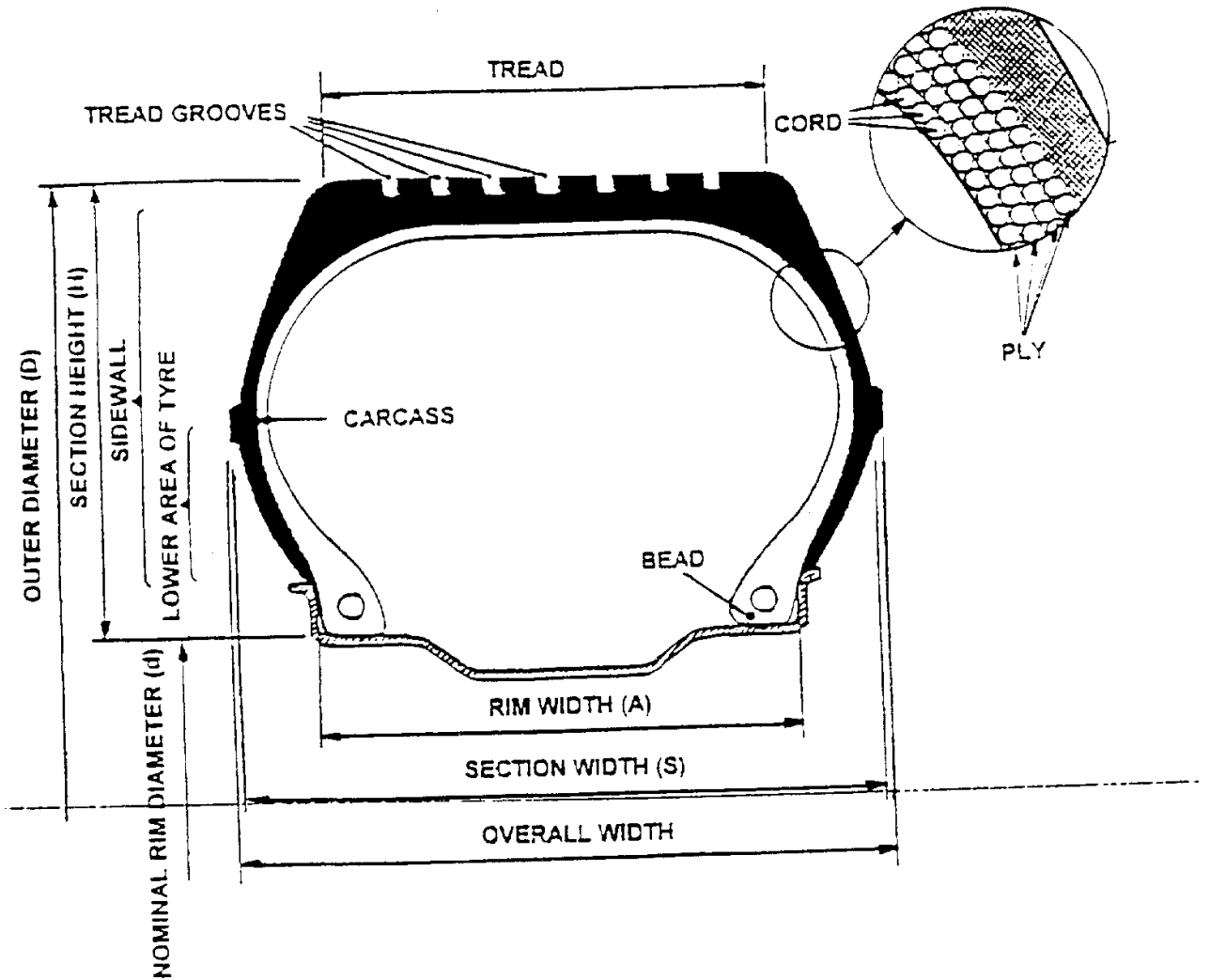

Annex 1

COMMUNICATION

(maximum format: A4 (210 x 297 mm))



issued by:

Name of administration:

.....
.....
.....

concerning 2/: APPROVAL GRANTED
APPROVAL EXTENDED
APPROVAL REFUSED
APPROVAL WITHDRAWN
PRODUCTION DEFINITELY DISCONTINUED

of a type of pneumatic tyre for motor vehicles pursuant to Regulation No. 30

Approval No.

Extension No.

1. Manufacturer's name or trade mark(s) on the tyre type:
2. Tyre type designation by the manufacturer:
3. Manufacturer's name and address:
4. If applicable, name and address of manufacturer's representative:
5. Summarized description:
- 5.1. Tyre size designation:
- 5.2. Category of use: normal/snow/temporary use 2/

- 5.3. Structure: diagonal/bias-belted/radial/run flat tyre 2/
- 5.4. Speed category symbol:
- 5.5. Load-capacity index:
6. Technical Service and, where applicable, test laboratory approved for purposes of approval or of verification of conformity:
7. Date of report issued by that service:
8. Number of report issued by that service:
9. Reason(s) of extension (if applicable):
10. Any remarks:
11. Approval granted/extended/refused/withdrawn 2/
12. Place:
13. Date:
14. Signature:
15. Annexed to this communication is a list of documents in the approval file deposited at the Administrative services having delivered the approval and which can be obtained upon request.

1/ Distinguishing number of the country which has granted/extended/refused/withdrawn approval (see approval provisions in the Regulation).

2/ Strike out what does not apply.

Annex 2

EXAMPLE OF THE ARRANGEMENT OF THE APPROVAL MARK

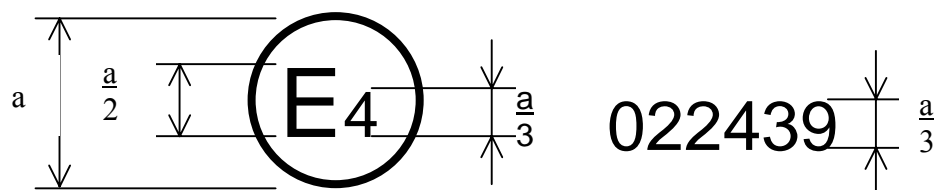

$a = 12 \text{ mm min.}$

The above approval mark affixed to a pneumatic tyre shows that the type of tyre concerned has been approved in the Netherlands (E 4) under approval number 022439.

Note: The first two digits of the approval number indicate that the approval was granted in accordance with the requirements of this Regulation as amended by the 02 series of amendments.

The approval number must be placed close to the circle and either above or below the "E" or to left or right of that letter. The digits of the approval number must be on the same side of the "E" and face in the same direction. The use of Roman numerals as approval numbers should be avoided so as to prevent any confusion with other symbols.

R is an indication of the structure of the tyre – see paragraph 3.1.3. of this Regulation,

400 is the nominal diameter of the rim expressed in mm,

A is the tyre to rim fitment configuration.

The marking of the load index, speed category, date of manufacture and other markings, shall be as given in example 1 above.

3. The positioning and order of the markings constituting the tyre designation shall be the following:

- (a) the size designation as defined in paragraph 2.17. of this Regulation shall be grouped as shown in the above examples: 185/70 R 14 and 185-560 R 400A;
- (b) the service description comprising the load index and the speed symbol shall be placed immediately after the tyre size designation as defined in paragraph 2.17. of this Regulation;
- (c) the symbols "tubeless", "reinforced", and "M + S" may be at a distance from the size-designation.

Annex 4

LOAD-CAPACITY INDICES

Li = Load-capacity index

kg = Corresponding mass of the vehicle which is to be carried.

Li	kg	Li	kg	Li	kg	Li	kg
0	45	31	109	61	257	91	615
1	46.2	32	112	62	265	92	630
2	47.5	33	115	63	272	93	650
3	48.7	34	118	64	280	94	670
4	50	35	121	65	290	95	690
5	51.5	36	125	66	300	96	710
6	53	37	128	67	307	97	730
7	54.5	38	132	68	315	98	750
8	56	39	136	69	325	99	775
9	58	40	140	70	335	100	800
10	60	41	145	71	345	101	825
11	61.5	42	150	72	355	102	850
12	63	43	155	73	365	103	875
13	65	44	160	74	375	104	900
14	67	45	165	75	387	105	925
15	69	46	170	76	400	106	950
16	71	47	175	77	412	107	975
17	73	48	180	78	425	108	1 000
18	75	49	185	79	437	109	1 030
19	77.5	50	190	80	450	110	1 060
20	80	51	195	81	462	111	1 090
21	82.5	52	200	82	475	112	1 120
22	85	53	206	83	487	113	1 150
23	87.5	54	212	84	500	114	1 180
24	90	55	218	85	515	115	1 215
25	92.5	56	224	86	530	116	1 250
26	95	57	230	87	545	117	1 285
27	97.5	58	236	88	560	118	1 320
28	100	59	243	89	580	119	1 360
29	103	60	250	90	600	120	1 400
30	106						

Annex 5

TYRE SIZE DESIGNATION AND DIMENSIONS

Table I. Tyres in Diagonal Construction (European tyres)

Size	Measuring rim width code	Overall diameter <u>1</u> / mm	Tyre section width <u>1</u> / mm	Nominal rim diameter "d" mm
Super Ballon Series				
4.80-10	3.5	490	128	254
5.20-10	3.5	508	132	254
5.20-12	3.5	558	132	305
5.60-13	4	600	145	330
5.90-13	4	616	150	330
6.40-13	4.5	642	163	330
5.20-14	3.5	612	132	356
5.60-14	4	626	145	356
5.90-14	4	642	150	356
6.40-14	4.5	666	163	356
5.60-15	4	650	145	381
5.90-15	4	668	150	381
6.40-15	4.5	692	163	381
6.70-15	4.5	710	170	381
7.10-15	5	724	180	381
7.60-15	5.5	742	193	381
8.20-15	6	760	213	381
Low Section Series				
5.50-12	4	552	142	305
6.00-12	4.5	574	156	305
7.00-13	5	644	178	330
7.00-14	5	668	178	356
7.50-14	5.5	688	190	356
8.00-14	6	702	203	356
6.00-15 L	4.5	650	156	381
Super Low Section Series <u>2</u>/				
155-13/6.15-13	4.5	582	157	330
165-13/6.45-13	4.5	600	167	330
175-13/6.95-13	5	610	178	330
155-14/6.15-14	4.5	608	157	356
165-14/6.45-14	4.5	626	167	356

Size	Measuring rim width code	Overall diameter <u>1</u> / mm	Tyre section width <u>1</u> / mm	Nominal rim diameter "d" mm
175-14/6.95-14	5	638	178	356
185-14/7.35-14	5.5	654	188	356
195-14/7.75-14	5.5	670	198	356
Ultra Low Section				
5.9-10	4	483	148	254
6.5-13	4.5	586	166	330
6.9-13	4.5	600	172	330
7.3-13	5	614	184	330

1/ Tolerance: see paragraphs 6.1.4. and 6.1.5.

2/ The following size designations are accepted: 185-14/7.35-14 or 185-14 or 7.35-14 or 7.35-14/185-14.

Table II. Millimetric Series - Radial (European tyres)

Size	Measuring rim width code	Overall diameter <u>1</u> / mm	Tyre section width <u>1</u> / mm	Nominal rim diameter "d" mm
125 R 10	3.5	459	127	254
145 R 10	4	492	147	254
125 R 12	3.5	510	127	305
135 R 12	4	522	137	305
145 R 12	4	542	147	305
155 R 12	4.5	550	157	305
125 R 13	3.5	536	127	330
135 R 13	4	548	137	330
145 R 13	4	566	147	330
155 R 13	4.5	578	157	330
165 R 13	4.5	596	167	330
175 R 13	5	608	178	330
185 R 13	5.5	624	188	330
125 R 14	3.5	562	127	356
135 R 14	4	574	137	356
145 R 14	4	590	147	356
155 R 14	4.5	604	157	356

Size	Measuring rim width code	Overall diameter ^{1/} mm	Tyre section width ^{1/} mm	Nominal rim diameter "d" mm
165 R 14	4.5	622	167	356
175 R 14	5	634	178	356
185 R 14	5.5	650	188	356
195 R 14	5.5	666	198	356
205 R 14	6	686	208	356
215 R 14	6	700	218	356
225 R 14	6.5	714	228	356
125 R 15	3.5	588	127	381
135 R 15	4	600	137	381
145 R 15	4	616	147	381
155 R 15	4.5	630	157	381
165 R 15	4.5	646	167	381
175 R 15	5	660	178	381
185 R 15	5.5	674	188	381
195 R 15	5.5	690	198	381
205 R 15	6	710	208	381
215 R 15	6	724	218	381
225 R 15	6.5	738	228	381
235 R 15	6.5	752	238	381
175 R 16	5	686	178	406
185 R 16	5.5	698	188	406
205 R 16	6	736	208	406

^{1/} Tolerance: see paragraphs 6.1.4. and 6.1.5.

Table III. 45 Series - Radial on TR Metric 5° Rims

Size	Measuring rim width	Overall diameter	Tyre section width
280/45 R 415	240	661	281

Annex 6

METHOD OF MEASURING PNEUMATIC TYRES

- 1.1. Mount the tyre on the measuring rim specified by the manufacturer pursuant to paragraph 4.1.12. of this Regulation and inflate it to a pressure of 3 to 3.5 bar.
- 1.2. Adjust the pressure as follows:
 - 1.2.1. in standard bias-belted tyres: to 1.7 bar;
 - 1.2.2. in diagonal (bias-ply) tyres: to:

Ply-rating	Pressure (bar)		
	Speed category		
	L, M, N	P, Q, R, S	T, U, H, V
4	1.7	2.0	-
6	2.1	2.4	2.6
8	2.5	2.8	3.0

- 1.2.3. in standard radial tyres: to 1.8 bar;
- 1.2.4. in reinforced tyres: to 2.3 bar;
- 1.2.5. in T-tyre temporary use spare tyres: to 4.2. bar.
2. Condition the tyre, mounted on its rim, at the ambient room temperature for not less than 24 hours, save as otherwise prescribed in paragraph 6.2.3. of this Regulation.
3. Readjust the pressure to the level specified in paragraph 1.2. above.
4. Measure the overall width by calliper at six equally-spaced points, taking the thickness of the protective ribs or bands into account. The highest measurement so obtained is taken as the overall width.
5. Determine the outer diameter by measuring the maximum circumference and dividing the figure so obtained by π (3.1416).

Annex 7

PROCEDURE FOR LOAD/SPEED PERFORMANCE TESTS

1. Preparing the tyre
 - 1.1. Mount a new tyre on the test rim specified by the manufacturer pursuant to paragraph 4.1.12. of this Regulation.
 - 1.2. Inflate it to the appropriate pressure as given (in bar) in the table below:

T-type temporary use spare tyres: to 4.2 bar.

Speed category	Diagonal (bias-ply) tyres			Radial/Run flat system		Bias-belted tyres
	Ply rating			Standard	Reinforced	Standard
	4	6	8			
L, M, N	2.3	2.7	3.0	2.4	2.8	-
P, Q, R, S	2.6	3.0	3.3	2.6	3.0	2.6
T, U, H	2.8	3.2	3.5	2.8	3.2	2.8
V	3.0	3.4	3.7	3.0	3.4	-
W	-	-	-	3.2	3.6	-
Y	-	-	-	3.2 ^{1/}	3.6	-

- 1.3. The manufacturer may request, giving reasons, the use of a test-inflation pressure differing from those given under paragraph 1.2. above. In such a case the tyre shall be inflated to that pressure.
- 1.4. Condition the tyre-and-wheel assembly at test-room temperature for not less than three hours.

^{1/} The value of "3.2" in respect of Speed Category "Y" tyres was inadvertently omitted from Supplement 5 to the 02 series of amendments which entered into force on 8 January 1995 and may be considered as a Corrigendum to this Supplement and to have been effective from that same date.

- 1.5. Readjust the tyre pressure to that specified in paragraph 1.2. or 1.3. above.
2. Carrying out the test
 - 2.1. Mount the tyre-and-wheel assembly on a test axle and press it against the outer face of a smooth wheel $1.70\text{ m} \pm 1$ per cent or $2\text{ m} \pm 1$ per cent in diameter.
 - 2.2. Apply to the test axle a load equal to 80 per cent of:
 - 2.2.1. the maximum load rating equated to the Load Capacity Index for tyres with Speed Symbols L to H inclusive,
 - 2.2.2. the maximum load rating associated with a maximum speed of 240 km/h for tyres Speed Symbol "V" (see para. 2.31.2. of this Regulation).
 - 2.2.3. the maximum load rating associated with a maximum speed of 270 km/h for tyres with speed symbol "W" (see paragraph 2.31.3. of this Regulation).
 - 2.2.4. the maximum load rating associated with a maximum speed of 300 km/h for tyres with speed symbol "Y" (see paragraph 2.31.4. of this Regulation).
 - 2.3. Throughout the test the tyre pressure must not be corrected and the test load must be kept constant.
 - 2.4. During the test the temperature in the test-room must be maintained at between 20° and 30° or at a higher temperature if the manufacturer agrees.
 - 2.5. Carry the test through, without interruption in conformity with the following particulars:
 - 2.5.1. time taken to pass from zero speed to initial test speed: 10 minutes;
 - 2.5.2. initial test speed: prescribed maximum speed for the type of tyre (see para. 2.29.3 of this Regulation), less 40 km/h in the case of the smooth wheel having $1.70\text{ m} \pm 1$ per cent in diameter or less 30 km/h in the case of the smooth wheel having $2\text{ m} \pm 1$ per cent in diameter;
 - 2.5.3. successive speed increments: 10 km/h;
 - 2.5.4. duration of test at each speed step except the last: 10 minutes;
 - 2.5.5. duration of test at last speed step: 20 minutes;

- 2.5.6. maximum test speed: prescribed maximum speed for the type of tyre, less 10 km/h in the case of the smooth wheel having $1.7 \text{ m} \pm 1$ per cent in diameter or equal to the prescribed maximum speed in the case of the smooth wheel having $2 \text{ m} \pm 1$ per cent in diameter.
- 2.5.7. however, for tyres suitable for maximum speed of 300 km/h (speed symbol "Y"), the duration of the test is 20 minutes at the initial test speed step and 10 minutes at the last speed step.
- 2.6. The procedure for the second test (see paragraph 6.2.1.1.), to assess the performance of a tyre suitable for speeds in excess of 300 km/h, shall be as follows:
- 2.6.1. Apply to the test axle a load equal to 80 per cent of the maximum load rating associated with the maximum speed specified by the tyre manufacturer (see paragraph 4.1.15. of this Regulation).
- 2.6.2. The test shall be run without interruptions in accordance with the following:
- 2.6.2.1. Ten minutes to build up from zero to the maximum speed specified by the tyre manufacturer (see paragraph 4.1.15. of this Regulation).
- 2.6.2.2. Five minutes at the maximum test speed.
3. Procedure to assess the "flat tyre running mode" of "run flat system"
- 3.1. Mount a new tyre on the test rim specified by the manufacturer pursuant to paragraphs 4.1.12. and 4.1.15. of this Regulation.
- 3.2. Carry out the procedure as detailed in paragraphs 1.2. to 1.5. above with a test room temperature at $38 \text{ }^\circ\text{C} \pm 3 \text{ }^\circ\text{C}$ in relation to conditioning the tyre-and-wheel assembly as detailed in paragraph 1.4.
- 3.3. Remove the valve insert and wait until the tyre deflates completely.
- 3.4. Mount the tyre-and-wheel assembly to a test axle and press it against the outer surface of a smooth wheel $1.70 \text{ m} \pm 1$ per cent or $2.0 \text{ m} \pm 1$ per cent in diameter.
- 3.5. Apply to the test axle a load equal to 65 per cent of the maximum load rating corresponding to the load capacity index of the tyre.
- 3.6. At the start of the test, measure the deflected section height (Z1).
- 3.7. During the test the temperature of the test room must be maintained at $38^\circ\text{C} \pm 3^\circ\text{C}$.

- 3.8. Carry the test through, without interruption in conformity with the following particulars:
- 3.8.1. time taken to pass from zero speed to constant test speed: 5 minutes
- 3.8.2. test speed: 80 km/h
- 3.8.3. duration of test at the test speed: 60 minutes
- 3.9. At the end of the test, measure the deflected section height (Z2).
- 3.9.1. Calculate the change in per cent of the deflected section height compared to the deflected section height at the start of the test as $((Z1 - Z2) / Z1) \times 100$.

4. Equivalent test methods

If a method other than that described in paragraphs 2. and/or 3. above is used, its equivalence must be demonstrated.
