

1 August 2000

AGREEMENT

CONCERNING THE ADOPTION OF UNIFORM TECHNICAL PRESCRIPTIONS FOR WHEELED VEHICLES, EQUIPMENT AND PARTS WHICH CAN BE FITTED AND/OR BE USED ON WHEELED VEHICLES AND THE CONDITIONS FOR RECIPROCAL RECOGNITION OF APPROVALS GRANTED ON THE BASIS OF THESE PRESCRIPTIONS */

(Revision 2, including the amendments entered into force on 16 October 1995)

Addendum 12: Regulation No. 13

Revision 4

Incorporating:

- 01 series of amendments - Date of entry into force: 29 August 1973
- 02 series of amendments - Date of entry into force: 11 July 1974
- 03 series of amendments - Date of entry into force: 4 January 1979
- 04 series of amendments - Date of entry into force: 11 August 1981
- 05 series of amendments - Date of entry into force: 26 November 1984
- Supplement 1 to the 05 series of amendments - Date of entry into force: 1 April 1987
- Supplement 2 to the 05 series of amendments - Date of entry into force: 5 October 1987
- Supplement 3 to the 05 series of amendments - Date of entry into force: 29 July 1988
- 06 series of amendments - Date of entry into force: 22 November 1990
- Supplement 1 to the 06 series of amendments - Date of entry into force: 15 November 1992
- Supplement 2 to the 06 series of amendments - Date of entry into force: 24 August 1993
- 07 series of amendments - Date of entry into force: 18 September 1994
- 08 series of amendments - Date of entry into force: 26 March 1995
- Supplement 1 to the 08 series of amendments - Date of entry into force: 28 August 1996
- 09 series of amendments - Date of entry into force: 28 August 1996
- Supplement 1 to the 09 series of amendments - Date of entry into force: 15 January 1997
- Supplement 2 to the 09 series of amendments - Date of entry into force: 22 February 1997
- Corrigendum 1 to the 09 series of amendments subject of Depository Notification C.N.223.1997.TREATIES-40 dated 23 June 1997
- Corrigendum 2 to the 09 series of amendments subject of Depository Notification C.N.420.1997.TREATIES-90 dated 27 October 1997
- Corrigendum 1 to Supplement 2 to the 09 series of amendments subject of Depository Notification C.N.224.1997.TREATIES-41 dated 20 June 1997
- Corrigendum 2 to Supplement 2 to the 09 series of amendments subject of Depository Notification C.N.267.1999.TREATIES-1 dated 20 July 1999
- Corrigendum 1 to Revision 3 subject of Depository Notification C.N.419.1997.TREATIES-89 dated 27 October 1997
- Corrigendum 2 to Revision 3 (Erratum - Russian only)
- Supplement 3 to the 09 series of amendments - Date of entry into force: 27 April 1998
- Supplement 4 to the 09 series of amendments - Date of entry into force: 4 February 1999

UNIFORM PROVISIONS CONCERNING THE APPROVAL OF VEHICLES OF CATEGORIES M, N AND O WITH REGARD TO BRAKING



UNITED NATIONS

*/ Former title of the Agreement:

Agreement Concerning the Adoption of Uniform Conditions of Approval and Reciprocal Recognition of Approval for Motor Vehicle Equipment and Parts, done at Geneva on 20 March 1958.

GE.00-

Regulation No. 13

UNIFORM PROVISIONS CONCERNING THE APPROVAL OF VEHICLES OF
CATEGORIES M, N AND O WITH REGARD TO BRAKING

CONTENTS

REGULATION	<u>Page</u>
1. Scope	7
2. Definitions	7
3. Application for approval	14
4. Approval	16
5. Specifications	16
6. Tests	43
7. Modification of vehicle type or braking system and extension of approval	43
8. Conformity of production	44
9. Penalties for non-conformity of production	45
10. Production definitely discontinued	45
11. Names and addresses of Technical Services conducting approval tests and of administrative departments	45
12. Transitional provisions	46

ANNEXES

<u>Annex 1</u> : Braking equipment, devices, methods and conditions not covered by this Regulation	48
<u>Annex 2</u> : Communication concerning the approval or extension or refusal or withdrawal of approval or production definitely discontinued of a vehicle type with regard to braking, pursuant to Regulation No. 13	49
<u>Annex 2 - Appendix 1</u> - List of vehicle data for the purpose of Regulation No. 90 approvals	54

CONTENTS (continued)

	<u>Page</u>
<u>Annex 3</u> : Arrangements of approval marks	56
<u>Annex 4</u> : Braking tests and performance of braking systems	58
<u>Annex 5</u> : Additional provisions applicable to vehicles	

	subject to marginal 10221 of annex B of ADR */	75
<u>Annex 6:</u>	Method of measuring the response time on vehicles equipped with compressed-air braking systems	77
	<u>Annex 6 - Appendix</u> - Example of a simulator	81
<u>Annex 7:</u>	Provisions relating to energy sources and energy storage devices (Energy accumulators)	83
<u>Annex 8:</u>	Provisions relating to specific conditions for spring braking systems	92
<u>Annex 9:</u>	Provisions relating to parking braking systems equipped with a mechanical brake-cylinder locking device (Lock actuators)	95
<u>Annex 10:</u>	Distribution of braking among the axles of vehicles and requirements for compatibility between towing vehicles and trailers	96
<u>Annex 11:</u>	Cases in which Type-I and/or Type-II (or Type-II A) tests do not have to be carried out	116
	<u>Annex 11 - Appendix 1</u> - Tables I, II and III	118
	<u>Annex 11 - Appendix 2</u> - Alternative procedures for Type-I and Type-II tests for trailer brakes	120
	<u>Annex 11 - Appendix 3</u> - Model test report form as prescribed in paragraph 3.6. of appendix 2 to this annex	128
<u>Annex 12:</u>	Conditions governing the testing of vehicles equipped with inertia (overrun) braking systems	133
	<u>Annex 12 - Appendix 1</u> - Figures 1-8	144

CONTENTS (continued)

	<u>Page</u>
<u>Annex 12 - Appendix 2</u> - Test report on inertia-braking system control device	150
<u>Annex 12 - Appendix 3</u> - Brake test report	153
<u>Annex 12 - Appendix 4</u> - Test report on the compatibility of the inertia brake control device, the transmission and the brakes on the trailer	155
<u>Annex 13:</u> Test requirements for vehicles fitted with anti-lock systems	159
<u>Annex 13 - Appendix 1</u> - Symbols and definitions	171
<u>Annex 13 - Appendix 2</u> - Utilization of adhesion	174

*/ European Agreement concerning the International Carriage of Dangerous Goods by Road, as amended.

<u>Annex 13 - Appendix 3</u>	- Performance on differing adhesion surfaces	180
<u>Annex 13 - Appendix 4</u>	- Method of selection of the low-adhesion surfaces	181
<u>Annex 14:</u>	Test conditions for trailers with electrical braking systems	183
<u>Annex 14 - Appendix</u>	- Compatibility of the braking rate of the trailer and the mean fully developed deceleration of the tractor/trailer combination (trailer laden and unladen)	186
<u>Annex 15:</u>	Inertia dynamometer test method for brake linings	187

1. SCOPE

- 1.1. This Regulation applies to the braking of power-driven vehicles individually and of trailers individually of categories M, N and O as defined in annex 7 to the Consolidated Resolution on the Construction of Vehicles (R.E.3). */
- 1.2. This Regulation does not cover:
- 1.2.1. vehicles with a design speed not exceeding 25 km/h;
- 1.2.2. trailers which may not be coupled to power-driven vehicles with a design speed exceeding 25 km/h;
- 1.2.3. vehicles fitted for invalid drivers;
- 1.3. Subject to the applicable provisions of this Regulation, the equipment, devices, methods and conditions enumerated in annex 1 are not covered by this Regulation.

2. DEFINITIONS

For the purposes of this Regulation,

- 2.1. "Approval of a vehicle" means the approval of a vehicle type with regard to braking;
- 2.2. "Vehicle type" means a category of vehicles which do not differ in such essential respects as:
- 2.2.1. in the case of power-driven vehicle,
- 2.2.1.1. the vehicle category, (see paragraph 1.1. above);
- 2.2.1.2. the maximum mass, as defined in paragraph 2.16. below;
- 2.2.1.3. the distribution of mass among the axles;
- 2.2.1.4. the maximum design speed;
- 2.2.1.5. a different type of braking equipment, with more particular reference to the presence or otherwise of equipment for braking a trailer, or any presence of an electric regenerative braking system;
- 2.2.1.6. the number and arrangement of the axles;
- 2.2.1.7. the engine type;
- 2.2.1.8. the number and ratios of gears;
- 2.2.1.9. the final drive ratios;
- 2.2.1.10. the tyre dimensions;
- 2.2.2. in the case of trailers,

*/ An alternative set of requirements for category M₁ vehicles is offered in Regulation No. 13-H. Contracting Parties that are signatories both to Regulation No. 13-H and this Regulation recognize approvals to either Regulation as equally valid.

- 2.2.2.1. the vehicle category (see paragraph 1.1. above);
- 2.2.2.2. the maximum mass, as defined in paragraph 2.16. below;
- 2.2.2.3. the distribution of mass among the axles;
- 2.2.2.4. a different type of braking equipment;
- 2.2.2.5. the number and arrangement of the axles;
- 2.2.2.6. the tyre dimensions;
- 2.3. "Braking system" means the combination of parts whose function is progressively to reduce the speed of a moving vehicle or bring it to a halt, or to keep it stationary if it is already halted; these functions are specified in paragraph 5.1.2. The system consists of the control, the transmission, and the brake proper;
- 2.4. "Control" means the part actuated directly by the driver (or in the case of some trailers, by an assistant) to furnish to the transmission the energy required for braking or controlling it. This energy may be the muscular energy of the driver, or energy from another source controlled by the driver, or in appropriate cases the kinetic energy of a trailer, or a combination of these various kinds of energy;
 - 2.4.1. "Actuation" means both application and release of the control.
- 2.5. "Transmission" means the combination of components comprised between the control and the brake and linking them functionally. The transmission may be mechanical, hydraulic, pneumatic, electric or mixed. Where the braking power is derived from or assisted by a source of energy independent of the driver but controlled by him, the reserve of energy in the system is likewise part of the transmission.

The transmission is divided into two independent functions: the control transmission and the energy transmission. Whenever the term "transmission" is used alone in this Regulation, it means both the "control transmission" and the "energy transmission". The control and supply lines between towing vehicles and trailers shall not be considered as parts of the transmission.

 - 2.5.1. "Control transmission" means the combination of the components of the transmission which control the operation of the brakes, including the control function and the necessary reserve(s) of energy.
 - 2.5.2. "Energy transmission" means the combination of the components which supply to the brakes the necessary energy for their function, including the reserve(s) of energy necessary for the operation of the brakes.
- 2.6. "Brake" means the part in which the forces opposing the movement of the vehicle develop. It may be a friction brake (when the forces are generated by friction between two parts of the vehicle moving relatively to one another); an electrical brake (when the forces are generated by electro-magnetic action between two parts of the vehicle moving relatively to but not in contact with one another); a fluid brake (when the forces are generated by the action of a fluid situated between two parts of the vehicle moving relatively to one another); or an engine brake (when the forces are derived from an artificial increase in the braking action,

transmitted to the wheels, of the engine);

- 2.7. "Different types of braking systems" means systems which differ in such essential respects as:
- 2.7.1. components having different characteristics;
 - 2.7.2. a component made of materials having different characteristics, or a component differing in shape or size;
 - 2.7.3. a different assembly of the components;
- 2.8. "Component of a braking system" means one of the individual parts which, when assembled, constitute the braking system;
- 2.9. "Continuous braking" means the braking of a combination of vehicles through an installation having the following characteristics:
- 2.9.1. a single control which the driver actuates progressively, by a single movement, from his driving seat;
 - 2.9.2. the energy used for braking the vehicles constituting the combination is furnished by the same source (which may be the muscular energy of the driver);
 - 2.9.3. the braking installation ensures simultaneous or suitably-phased braking of each of the constituent vehicles of the combination, whatever their relative positions;
- 2.10. "Semi-continuous braking" means the braking of a combination of vehicles through an installation having the following characteristics:
- 2.10.1. a single control which the driver actuates progressively, by a single movement, from his driving seat;
 - 2.10.2. the energy used for braking the vehicles constituting the combination is furnished by two different sources (one of which may be the muscular energy of the driver);
 - 2.10.3. the braking installation ensures simultaneous or suitably-phased braking of each of the constituent vehicles of the combination, whatever their relative positions;
- 2.11. "Automatic braking" means braking of the trailer or trailers occurring automatically in the event of separation of components of the combination of coupled vehicles, including such separation through the breakage of a coupling, the effectiveness of the braking of the remainder of the combination not being thereby destroyed;
- 2.12. "Inertia (or overrun) braking" means braking by utilizing the forces generated by the trailer's moving up on the towing vehicle;
- 2.13. "Progressive and graduated braking" means braking during which, within the normal operating range of the equipment, and during actuation of the brakes (see paragraph 2.4.1. above);
- 2.13.1. the driver can at any moment increase or decrease the braking force by acting on the control;
 - 2.13.2. the braking force varies proportionally as the action on the control (monotonic function); and

- 2.13.3. the braking force can be easily regulated with sufficient precision;
- 2.14. "Endurance braking system" 1/ means an additional braking system having the capability to provide and to maintain a braking effect over a long period of time without a significant reduction in performance. The term "endurance braking system" covers the complete system including the control device,
- 2.14.1. The endurance braking system may comprise a single device or a combination of several devices. Each device may have its own control.
- 2.14.2. Control configurations for endurance braking systems:
- 2.14.2.1. "Independent endurance braking system" means an endurance braking system whose control device is separated from that of the service and other braking systems,
- 2.14.2.2. "Integrated endurance braking system" 2/ means an endurance braking system whose control device is integrated with that of the service braking system in such a way that both endurance and service braking systems are applied simultaneously or suitably phased by operation of the combined control device,
- 2.14.2.3. "Combined endurance braking system" means an integrated endurance braking system, which in addition has a cut-out device, which allows the combined control to apply the service braking system alone.
- 2.15. "Laden vehicle" means, except where otherwise stated, a vehicle so laden as to attain its "maximum mass";
- 2.16. "Maximum mass" means the maximum mass stated by the vehicle manufacturer to be technically permissible (this mass may be higher than the "permissible maximum mass" laid down by the national administration);
- 2.17. "The distribution of mass among the axles" means the distribution of the effect of the gravity on the mass of the vehicle and/or its contents among the axles;
- 2.18. "Wheel/axle load" means the vertical static reaction (force) of the road surface in the contact area on the wheel/wheels of the axle;

1/ Until uniform procedures have been agreed to calculate the effects of endurance braking systems on the provisions in annex 10 to this Regulation, this definition does not cover vehicles fitted with regenerative braking systems.

2/ Until uniform procedures have been agreed to calculate the effects of endurance braking systems on the provisions in annex 10 to this Regulation, vehicles equipped with an integrated endurance braking system must also be equipped with an anti-lock system acting at least on the service brakes of the endurance braking system controlled axle and on the endurance braking system itself, and tested according to the provisions of annex 13 to this Regulation.

- 2.19. "Maximum stationary wheel/axle load" means the stationary wheel/axle load achieved under the condition of the laden vehicle;
- 2.20. "Electric vehicle" means a vehicle in which the traction is effected only by (an) electric motor(s) acting at least on one axle.
- 2.20.1. "Electric regenerative braking system" means a braking system which allows the use of the vehicle's drive motor(s) to convert the vehicle's kinetic energy into electrical energy during deceleration.
- 2.20.2. "Electric regenerative braking control" means a device which modulates the action of the electric regenerative braking system.
- 2.20.3. "Electric regenerative braking system of category A" means an electric regenerative braking system which is not part of the service braking system.
- 2.20.4. "Electric regenerative braking systems of category B" means an electric regenerative braking system which is part of the service braking system.
- 2.20.5. "Electric state of charge" means the instantaneous ratio of electric quantity of energy stored in the traction battery relative to the maximum quantity of electric energy which could be stored in this battery.
- 2.20.6. "Traction battery" means an assembly of accumulators constituting the storage of energy used for powering the traction motor(s) of the vehicle.
- 2.21. "Hydraulic braking system with stored energy" means a braking system where energy is supplied by a hydraulic fluid under pressure, stored in one or more accumulators fed from one or more pressure pumps, each fitted with a means of limiting the pressure to a maximum value. This value shall be specified by the manufacturer;
- 2.22. "Simultaneous lockup of the front and rear wheels" refers to the condition when the time interval between the first occurrence of lockup of the last (second) wheel on the rear axle and the first occurrence of lockup on the last (second) wheel on the front axle is less than 0.1 second. */
- 2.23. "Electric control line" means the electrical connection between power-driven vehicle and trailer which provides the braking control function to the trailer. It comprises the electrical wiring and connector and includes the parts for data communication and the electrical energy supply for the trailer control transmission.
- 2.24. "Data communication" means the transfer of digital data under the rules of a protocol.
- 2.25. "Point-to-point" means a topology of a communication network with only two units. Each unit has an integrated termination resistor for the communication line.

*/ For the definition of "actuation", see paragraph 2.4.1. (correction of re-numbering).

- 2.26. "Coupling force control" means a system/function to balance automatically the braking rate of towing vehicle and trailer.
- 2.27. "Nominal value" definitions for braking reference performance are required to put a value on the transfer function of the braking system, relating output to input for vehicles individually and when used in combination.
- 2.27.1. "Nominal value" is defined, for a power-driven vehicle, as the characteristic which can be demonstrated at Type Approval and which relates the braking rate of the vehicle on its own to the level of the braking input variable.
- 2.27.2. "Nominal value" is defined, for a trailer, as the characteristic which can be demonstrated at Type Approval and which relates the braking rate to the coupling head signal.
- 2.27.3. "Nominal demand value" is defined, for coupling force control, as the characteristic which relates the coupling head signal to the braking rate and which can be demonstrated at Type Approval, within the limits of the compatibility bands of annex 10.

3. APPLICATION FOR APPROVAL

- 3.1. The application for approval of a vehicle type with regard to braking shall be submitted by the vehicle manufacturer or by his duly accredited representative.
- 3.2. It shall be accompanied by the undermentioned documents in triplicate and by the following particulars:
- 3.2.1. a description of the vehicle type with regard to the items specified in paragraph 2.2. above. The numbers and/or symbols identifying the vehicle type and, in the case of power-driven vehicles, the engine type shall be specified;
- 3.2.2. a list of the components, duly identified, constituting the braking system;
- 3.2.3. a diagram of assembled braking system and an indication of the position of its components on the vehicle;
- 3.2.4. detailed drawings of each component to enable it to be easily located and identified.
- 3.3. A vehicle, representative of the vehicle type to be approved, shall be submitted to the Technical Service conducting the approval tests.
- 3.4. The competent authority shall verify the existence of satisfactory arrangements for ensuring effective control of the conformity of production before type approval is granted.

4. APPROVAL

- 4.1. If the vehicle type submitted for approval pursuant to this Regulation meets the requirements of paragraphs 5 and 6 below, approval of that vehicle type shall be granted.
- 4.2. An approval number shall be assigned to each type approved, its first two digits (at present 09) shall indicate the series of amendments incorporating the most recent major technical amendments

made to the Regulation at the time of issue of the approval. The same Contracting Party shall not assign the same number to the same vehicle type equipped with another type of braking system, or to another vehicle type.

- 4.3. Notice of approval or of refusal of approval of a vehicle type pursuant to this Regulation shall be communicated to the Parties to the Agreement applying this Regulation by means of a form conforming to the model in annex 2 to this Regulation and of a summary of the information contained in the documents referred to in paragraphs 3.2.1. to 3.2.4. above, the drawings supplied by the applicant being in a format not exceeding A4 (210 x 297 mm), or folded to that format, and on an appropriate scale.
- 4.4. There shall be affixed, conspicuously and in a readily accessible place specified on the approval form, to every vehicle conforming to a vehicle type approved under this Regulation, an international approval mark consisting of:

- 4.4.1. a circle surrounding the letter "E" followed by the distinguishing number of the country which has granted approval, 3/ and
- 4.4.2. the number of this Regulation, followed by the letter "R", a dash and the approval number to the right of the circle prescribed in paragraph 4.4.1. above.
- 4.5. However, if a vehicle of categories M₂ or M₃ has been approved pursuant to the provisions of annex 5 to this Regulation, the number of the Regulation shall be followed by the letter M.
- 4.6. If the vehicle conforms to a vehicle type approved under one or more other Regulations, annexed to the Agreement, in the country which has granted approval under this Regulation, the symbol prescribed in paragraph 4.4.1. need not be repeated; in such a case, the Regulation and approval numbers and the additional symbols of all the Regulations under which approval has been granted in the country which has granted approval under this Regulation shall be placed in vertical columns to the right of the symbol prescribed in paragraph 4.4.1. above.
- 4.7. The approval mark shall be clearly legible and be indelible.
- 4.8. The approval mark shall be placed close to or on the vehicle data plate.
- 4.9. Annex 3 to this Regulation gives examples of arrangements of approval marks.
5. SPECIFICATIONS
- 5.1. General
- 5.1.1. Braking system
- 5.1.1.1. The braking system shall be so designed, constructed and fitted as to enable the vehicle in normal use, despite the vibration to which it may be subjected, to comply with the provisions of this Regulation.

3/ 1 for Germany, 2 for France, 3 for Italy, 4 for the Netherlands, 5 for Sweden, 6 for Belgium, 7 for Hungary, 8 for the Czech Republic, 9 for Spain, 10 for Yugoslavia, 11 for the United Kingdom, 12 for Austria, 13 for Luxembourg, 14 for Switzerland, 15 (vacant), 16 for Norway, 17 for Finland, 18 for Denmark, 19 for Romania, 20 for Poland, 21 for Portugal, 22 for the Russian Federation, 23 for Greece, 24 for Ireland, 25 for Croatia, 26 for Slovenia, 27 for Slovakia, 28 for Belarus, 29 for Estonia, 30 (vacant), 31 for Bosnia and Herzegovina, 32 for Latvia, 33 (vacant), 34 for Bulgaria, 35-36 (vacant), 37 for Turkey, 38-39 (vacant), 40 for The former Yugoslav Republic of Macedonia, 41 (vacant), 42 for the European Community (Approvals are granted by its Member States using their respective ECE symbol), 43 for Japan, 44 (vacant), 45 for Australia and 46 for Ukraine. Subsequent numbers shall be assigned to other countries in the chronological order in which they ratify or accede to the Agreement Concerning the Adoption of Uniform Technical Prescriptions for Wheeled Vehicles, Equipment and Parts which can be Fitted and/or be Used on Wheeled Vehicles and the Conditions for Reciprocal Recognition of Approvals Granted on the Basis of these Prescriptions, and the numbers thus assigned shall be communicated by the Secretary-General of the United Nations to the Contracting Parties to the Agreement.

- 5.1.1.2. In particular, the braking system shall be so designed, constructed and fitted as to be able to resist the corroding and ageing phenomena to which it is exposed.
- 5.1.1.3. Brake linings shall not contain asbestos.
- 5.1.1.4. The effectiveness of the braking systems, including the electric control line, shall not be adversely affected by magnetic or electrical fields. This shall be demonstrated by compliance with Regulation No. 10, 02 series of amendments.
- 5.1.1.5. A failure detection signal may interrupt momentarily (< 10 ms) the demand signal in the control transmission, provided that the braking performance is thereby not reduced.
- 5.1.2. Functions of the braking system
- The braking system defined in paragraph 2.3. of this Regulation must fulfil the following functions:
- 5.1.2.1. Service braking system
- The service braking system must make it possible to control the movement of the vehicle and to halt it safely, speedily and effectively, whatever its speed and load, on any up or down gradient. It must be possible to graduate this braking action. The driver must be able to achieve this braking action from his driving seat without removing his hands from the steering control.
- 5.1.2.2. Secondary braking system
- The secondary braking system must make it possible to halt the vehicle within a reasonable distance in the event of failure of the service braking system. It must be possible to graduate this braking action. The driver must be able to obtain this braking action from his driving seat while keeping at least one hand on the steering control. For the purposes of these provisions it is assumed that not more than one failure of the service braking system can occur at one time.
- 5.1.2.3. Parking braking system
- The parking braking system must make it possible to hold the vehicle stationary on an up or down gradient even in the absence of the driver, the working parts being then held in the locked position by a purely mechanical device. The driver must be able to achieve this braking action from his driving seat, subject, in the case of a trailer, to the provisions of paragraph 5.2.2.10. of this Regulation. The trailer air brake and the parking braking system of the towing vehicle may be operated simultaneously provided that the driver is able to check, at any time, that the parking brake performance of the vehicle combination, obtained by the purely mechanical action of the parking braking system, is sufficient.
- 5.1.3. Connections, for compressed-air braking systems, between power-driven vehicles and trailers
- 5.1.3.1. The connections of the compressed-air braking systems between power-driven vehicles and trailers shall be provided according to paragraphs 5.1.3.1.1., 5.1.3.1.2. or 5.1.3.1.3.:
- 5.1.3.1.1. One pneumatic supply line and one pneumatic control line;

- 5.1.3.1.2. One pneumatic supply line, one pneumatic control line and one electric control line;
- 5.1.3.1.3. One pneumatic supply line and one electric control line; this option is subject to footnote 4/.
- 5.1.3.2. The electric control line of the power-driven vehicle shall provide information as to whether the requirements of paragraph 5.2.1.18.2. can be satisfied by the electric control line, without assistance from the pneumatic control line. It shall also provide information as to whether it is equipped according to paragraph 5.1.3.1.2. with two control lines or according to paragraph 5.1.3.1.3. with only an electric control line.
- 5.1.3.3. A power-driven vehicle equipped according to paragraph 5.1.3.1.3. shall recognize that the coupling of a trailer equipped according to paragraph 5.1.3.1.1. is not compatible. When such vehicles are electrically connected via the electric control line of the towing vehicle, the driver shall be warned by the red optical warning signal specified in paragraph 5.2.1.29.1.1. and when the system is energized, the brakes on the towing vehicle shall be automatically applied. This brake application shall provide at least the prescribed parking braking performance required by paragraph 2.3.1. of annex 4 to this Regulation.
- 5.1.3.4. In the case of a power-driven (towing) vehicle equipped with two control lines as defined in paragraph 5.1.3.1.2., both control signals shall be present at the coupling head and connector. When such a power-driven vehicle is electrically connected to a trailer which is also equipped with two control lines as defined in paragraph 5.1.3.1.2., both signals shall be present at the trailer, and the trailer shall decide which control signal to use. If there is an electric control signal at the trailer which is not accompanied by a corresponding pneumatic control signal when the service braking control is applied, the driver shall be warned, from the trailer, by the separate yellow warning signal specified in paragraph 5.2.1.29.2.
- 5.1.3.5. A trailer may be equipped as defined in paragraph 5.1.3.1.3., provided that it can only be operated in conjunction with a power-driven vehicle with an electric control line which satisfies the requirements of paragraph 5.2.1.18.2. In any other case, the trailer, when electrically connected, shall automatically apply the brakes or remain braked. The driver shall be warned by the separate yellow warning signal specified in paragraph 5.2.1.28.2.
- 5.1.3.6. The electric control line shall conform to ISO/DIS 11992-1 and 11992-2:[1996] and be a point-to-point type using the seven pin connector ISO/DIS 7638:1996. *****/ Nevertheless, other information may be transferred by this line provided that this conforms to ISO/DIS 11992-3:[1996] and that braking functions have priority and are maintained in the normal and failed modes. The transmission of other information shall not delay braking functions.

4/ Until uniform technical standards have been agreed, which ensure compatibility and safety, connections between power-driven vehicles and trailers conforming to paragraph 5.1.3.1.3. shall not be permitted.

*/ The ISO/DIS 7638:1996 connector may be used for 5 pin or 7 pin applications, as appropriate.

- 5.1.3.6.1. When a power-driven vehicle is equipped with an electric control line and electrically connected to a trailer equipped with an electric control line, a continuous failure (> 40 ms) within the electric control line shall be detected in the power-driven vehicle and shall be signalled to the driver by the yellow warning signal specified in paragraph 5.2.1.29.1.2., when such vehicles are connected via the electric control line.
- 5.1.3.7. If the operation of the parking braking system on the power-driven vehicle also operates a braking system on the trailer, as permitted by paragraph 5.1.2.3., then the following additional requirements shall be met:
- 5.1.3.7.1. When the power-driven vehicle is equipped according to paragraph 5.1.3.1.1., the actuation of the parking brake system of the power-driven vehicle shall actuate a braking system on the trailer via the pneumatic control line.
- 5.1.3.7.2. When the power-driven vehicle is equipped according to paragraph 5.1.3.1.2., the actuation of the parking brake system on the power-driven vehicle shall actuate a braking system on the trailer as prescribed in paragraph 5.1.3.7.1. In addition, the actuation of the parking brake system may also actuate a braking system on the trailer via the electric control line.
- 5.1.3.7.3. When the power-driven vehicle is equipped according to paragraph 5.1.3.1.3. or, if it satisfies the requirements of paragraph 5.2.1.18.2. without assistance from the pneumatic control line, paragraph 5.1.3.1.2., the actuation of the parking braking system on the power-driven vehicle shall actuate a braking system on the trailer via the electric control line. When the electrical energy for the braking equipment of the power-driven vehicle is switched off, the braking of the trailer shall be effected by evacuation of the supply line (in addition, the pneumatic control line may remain pressurised); the supply line may only remain evacuated until the electrical energy for the braking equipment of the power-driven vehicle is restored and simultaneously the braking of the trailer via the electric control line is restored.
- 5.1.3.8. Shut-off devices which are not automatically actuated shall not be permitted. In the case of articulated vehicle combinations, the flexible hoses and cables shall be a part of the power-driven vehicle. In all other cases, the flexible hoses and cables shall be a part of the trailer.
- 5.1.4. Provisions for the periodic technical inspection of braking systems.
- 5.1.4.1. The braking system shall be so designed that the components of the braking system of which the function and efficiency is influenced by wear, can easily be checked.
- 5.1.4.2. For the purpose of determining the in-use braking forces of each axle of the vehicle, with a compressed-air braking system, air pressure test connections are required:
- 5.1.4.2.1. In each independent circuit of the braking system, at the closest readily accessible position to the brake cylinder which is the least favourably placed as far as the response time described in annex 6 is concerned.
- 5.1.4.2.2. In a braking system which incorporates a pressure modulation device

as referred to in paragraph 7.2. of annex 10, located in the pressure line upstream and downstream of this device at the closest accessible position. If this device is pneumatically controlled an additional test connection is required to simulate the laden condition. Where no such device is fitted, a single pressure test connection, equivalent to the downstream connector mentioned above, shall be provided. These test connections shall be so located as to be easily accessible from the ground or within the vehicle.

- 5.1.4.2.3. At the closest readily accessible position to the least favourably placed energy storage device within the meaning of paragraph 2.4. of annex 7, Section A.
- 5.1.4.2.4. In each independent circuit of the braking system so it is possible to check the input and output pressure of the complete transmission line.
- 5.1.4.2.5. The pressure test connections shall comply with clause 4 of ISO Standard 3583:1984.
- 5.1.4.3. The accessibility of required pressure test connections shall not be obstructed by modifications and assembly of accessories or the vehicle body.
- 5.1.4.4. It shall be possible to generate maximum braking forces under static conditions on a rolling road or roller brake tester.
- 5.1.4.5. Data for braking systems:
 - 5.1.4.5.1. The data of the compressed-air braking system for the functional and efficiency test must be specified at the vehicle in a visible position in indelible form, or made freely available in another way (e.g. handbook, electronic data recorder).
 - 5.1.4.5.2. for vehicles equipped with compressed-air braking systems at least the following data are required:

Pneumatic characteristic data:

compressor/unloader valve ⁽¹⁾	Max. cut-out pressure = bar	Min. cut-in pressure = bar
Four-circuit protection valve	Static closing pressure = bar	
Trailer control valve or relay emergency valve, as appropriate	Corresponding delivery pressure for a control pressure of 3.0 bar = bar	
Minimum design pressure in the service braking system for calculation ^{(1) (2)}		

				Axle(s)		
Brake cylinder type ⁽³⁾ Service / Parking	/	/	/			
Maximum stroke ⁽³⁾ $s_{max} = \dots\dots\dots$ mm						
Lever length ⁽³⁾ = $\dots\dots\dots$ mm						

- Notes:
- ⁽¹⁾ Not applicable for trailers;
 - ⁽²⁾ When different from minimum cut-in pressure;
 - ⁽³⁾ Only applicable for trailers.

5.2. Characteristics of braking systems

5.2.1. **Vehicles of categories M and N**

5.2.1.1. The set of braking systems with which a vehicle is equipped must satisfy the requirements laid down for service, secondary and parking braking systems.

5.2.1.2. The systems providing service, secondary and parking braking may have common components so long as they fulfil the following conditions:

5.2.1.2.1. there must be at least two controls, independent of each other and readily accessible to the driver from his normal driving position.

For all categories of vehicles, except M_2 and M_3 , every brake control (excluding an endurance braking system control) shall be designed such that it returns to the fully off position when released. This requirement shall not apply to a parking brake control (or that part of a combined control) when it is mechanically locked in an applied position;

5.2.1.2.2. the control of the service braking system must be independent of the control of the parking braking system;

5.2.1.2.3. if the service braking system and the secondary braking system have the same control, the effectiveness of the linkage between that control and the different components of the transmission systems must not be liable to diminish after a certain period of use;

5.2.1.2.4. if the service braking system and the secondary braking system have the same control, the parking braking system must be so designed that it can be actuated when the vehicle is in motion. This requirement shall not apply if the vehicle's service braking system can be actuated, even partially, by means of an auxiliary control;

5.2.1.2.5. Without prejudice to the requirements of paragraph 5.1.2.3. of this Regulation, the service braking system and the parking braking system may use common components in their transmission(s), provided that in the event of a failure in any part of the transmission(s) the requirements for secondary braking are still ensured;

5.2.1.2.6. in the event of breakage of any component other than the brakes (as defined in paragraph 2.6. of this Regulation) or the components referred to in paragraph 5.2.1.2.8. below, or of any

other failure of the service braking system (malfunction, partial or total exhaustion of an energy reserve), the secondary braking system or that part of the service braking system which is not affected by the failure, must be able to bring the vehicle to a halt in the conditions prescribed for secondary braking;

- 5.2.1.2.7. In particular, where the secondary braking system and the service braking system have a common control and a common transmission:
- 5.2.1.2.7.1. if service braking is ensured by the action of the driver's muscular energy assisted by one or more energy reserves, secondary braking must, in the event of failure of that assistance, be capable of being ensured by the driver's muscular energy assisted by the energy reserves, if any, which are unaffected by the failure, the force applied to the control not exceeding the prescribed maxima;
- 5.2.1.2.7.2. if the service braking force and transmission depend exclusively on the use, controlled by the driver, of an energy reserve, there must be at least two completely independent energy reserves, each provided with its own transmission likewise independent; each of them may act on the brakes of only two or more wheels so selected as to be capable of ensuring by themselves the prescribed degree of secondary braking without endangering the stability of the vehicle during braking; in addition, each of the aforesaid energy reserves must be equipped with a warning device as defined in paragraph 5.2.1.13. below. In each service braking circuit in at least one of the air reservoirs a device for draining and exhausting is required in an adequate and easily accessible position;
- 5.2.1.2.8. certain parts, such as the pedal and its bearing, the master cylinder and its piston or pistons (hydraulic systems), the control valve (hydraulic and/or pneumatic systems), the linkage between the pedal and the master cylinder or the control valve, the brake cylinders and their pistons (hydraulic and/or pneumatic systems), and the lever-and-cam assemblies of brakes, shall not be regarded as liable to breakage if they are amply dimensioned, are readily accessible for maintenance, and exhibit safety features at least equal to those prescribed for other essential components (such as the steering linkage) of the vehicle. Any such part as aforesaid whose failure would make it impossible to brake the vehicle with a degree of effectiveness at least equal to that prescribed for secondary braking must be made of metal or of a material with equivalent characteristics and must not undergo notable distortion in normal operation of the braking systems.
- 5.2.1.3. Where there are separate controls for the service braking system and the secondary braking system, simultaneous actuation of the two controls must not render both the service braking system and the secondary braking system inoperative, either when both braking systems are in good working order or when one of them is faulty.
- 5.2.1.4. The service braking system must, whether or not it is combined with the secondary braking system, be such that in the event of failure in a part of its transmission a sufficient number of wheels are still braked by actuation of the service brake control; these wheels must be so selected that the residual performance of the service braking system satisfies the

requirements laid down in paragraph 2.4. of annex 4 to this Regulation.

- 5.2.1.4.1. However, the foregoing provisions shall not apply to tractor vehicles for semi-trailers when the transmission of the semi-trailer's service braking system is independent of that of the tractor vehicle's service braking system;
- 5.2.1.4.2. The failure of a part of a hydraulic transmission system shall be signalled to the driver by a device comprising a red warning signal, as specified in paragraph 5.2.1.29.1.1. Alternatively, the lighting up of this device when the fluid in the reservoir is below a certain level specified by the manufacturer shall be permitted.
- 5.2.1.5. Where use is made of energy other than the muscular energy of the driver, there need not be more than one source of such energy (hydraulic pump, air compressor, etc.), but the means by which the device constituting that source is driven must be as safe as practicable.
- 5.2.1.5.1. In the event of failure in any part of the transmission of a braking system, the feed to the part not affected by the failure must continue to be ensured if required for the purpose of halting the vehicle with the degree of effectiveness prescribed for residual and/or secondary braking. This condition must be met by means of devices which can be easily actuated when the vehicle is stationary, or by automatic means.
- 5.2.1.5.2. Furthermore, storage devices located down-circuit of this device must be such that in the case of a failure in the energy supply after four full-stroke actuations of the service brake control, under the conditions prescribed in paragraph 1.2. of annex 7 to this Regulation, it is still possible to halt the vehicle at the fifth application, with the degree of effectiveness prescribed for secondary braking.
- 5.2.1.5.3. However, for hydraulic braking systems with stored energy, these provisions can be considered to be met provided that the requirements of paragraph 1.2.2. of Part C of annex 7 to this Regulation, are satisfied.
- 5.2.1.6. The requirements of paragraphs 5.2.1.2., 5.2.1.4. and 5.2.1.5. of this Regulation must be met without the use of any automatic device of a kind such that its ineffectiveness might pass unnoticed through the fact that parts normally in a position of rest come into action only in the event of failure in the braking system.
- 5.2.1.7. The service braking system:
- 5.2.1.7.1. shall act on all the wheels of the vehicle;
- 5.2.1.7.2. shall distribute its action appropriately among the axles; in the case of vehicles with more than two axles, in order to avoid wheel-locking or glazing of the brake linings, the brake force on certain axles may be reduced to zero automatically when carrying a much reduced load, provided that the vehicle meets all the performance requirements prescribed in annex 4 to this Regulation.

- 5.2.1.8. The action of the service braking system shall be distributed between the wheels of one and the same axle symmetrically in relation to the longitudinal median plane of the vehicle. Compensation and functions, such as anti-lock, which may cause deviations from this symmetrical distribution, and functions, such as traction control, which may cause application of the brakes not directly controlled by the driver, shall be declared. 5/
- 5.2.1.8.1. Compensation by the electric control transmission for deterioration or defect within the braking system shall be indicated to the driver by means of the yellow warning signal specified in paragraph 5.2.1.29.1.2. This requirement shall apply for all conditions of loading when compensation exceeds the following limits:
- 5.2.1.8.1.1. a difference in transverse braking pressures on any axle:
- (a) of 25 per cent of the higher value for vehicle decelerations $\geq 2\text{m/sec}^2$,
 - (b) a value corresponding to 25 per cent at 2m/sec^2 for decelerations below this rate.
- 5.2.1.8.1.2. an individual compensating value on any axle:
- (a) > 50 per cent of the nominal value for vehicle decelerations $\geq 2\text{ m/s}^2$,
 - (b) a value corresponding to 50 per cent of the nominal value at 2m/s^2 for decelerations below this rate.
- 5.2.1.8.2. Compensation as defined above, is permitted only when the initial brake application is made at vehicle speeds greater than 10 km/h.
- 5.2.1.9. Malfunctions of the electric control transmission shall not apply the brakes contrary to the driver's intentions.
- 5.2.1.10. The service braking system and the parking braking system must act on braking surfaces permanently connected to the wheels through components of adequate strength. No braking surface shall be capable of being disconnected from the wheels; however, in the case of the service braking system and the secondary braking system, such disconnection of the braking surfaces shall be permitted provided that it is only momentary, for instance during a change of gear, and that both the service braking and the secondary braking continue to operate with the prescribed degree of effectiveness. In addition, disconnections as aforesaid shall be permitted in the case of the parking braking system on condition that it is controlled exclusively by the driver from his driving seat by a system incapable of being brought into action by a leak.
- 5.2.1.11. Wear of the brakes must be capable of being easily taken up by

5/ Adequate performance specifications and the associated test procedures shall be presented by the manufacturer and shall be subject to discussion and agreement by the Technical Service (unless already covered by the present Regulation). For this purpose, the manufacturer shall provide documentation which covers: system layout, description of functions and safety concept.

means of a system of manual or automatic adjustment. In addition, the control and the components of the transmission and of the brakes must possess a reserve of travel and, if necessary, suitable means of compensation such that, when the brakes become heated, or the brake linings have reached a certain degree of wear, effective braking is ensured without immediate adjustment being necessary.

5.2.1.11.1. Wear adjustment shall be automatic for the service brakes. However, the fitting of automatic adjustment devices is optional for off-road vehicles of categories N_2 and N_3 and for rear brakes of vehicles of categories M_1 and N_1 . Automatic wear adjustment devices shall be such that after heating followed by cooling of the brakes, effective braking is still ensured. In particular the vehicle shall remain capable of normal running after the tests conducted in accordance with paragraph 1.5. (Type-I test) and paragraph 1.6. (Type-II test) of annex 4 to this Regulation.

5.2.1.11.2. It shall be possible to easily check this wear on service brake linings from the outside or underside of the vehicle utilizing only the tools or equipment normally supplied with the vehicle, for instance by the provision of appropriate inspection holes or by some other means. Alternatively, acoustic or optical devices warning the driver at his driving position when lining replacement is necessary are acceptable. The removal of front and/or rear wheels is permitted for this purpose on category M_1 and N_1 vehicles only.

The yellow warning signal specified in paragraph 5.2.1.29.1.2. may be used as the optical warning signal.

5.2.1.12. In hydraulic-transmission braking systems, the filling ports of the fluid reservoirs must be readily accessible; in addition, the receptacles containing the reserve fluid must be so designed and constructed that the level of the reserve fluid can be easily checked without the receptacles having to be opened. If this latter condition is not fulfilled, the red warning signal specified in paragraph 5.2.1.29.1.1. shall draw the driver's attention to any fall in the level of reserve fluid liable to cause a failure of the braking system. The type of fluid to be used in the hydraulic transmission braking systems shall be identified by the symbol in accordance with figure 1 or 2 of Standard ISO 9128:1987. The symbol must be affixed in a visible position in indelible form within 100 mm of the filling ports of the fluid reservoirs; additional information may be provided by the manufacturer.

5.2.1.13. Warning device

5.2.1.13.1. Any vehicle fitted with a service brake actuated from an energy reservoir must, where the prescribed secondary braking performance cannot be obtained by means of this braking system without the use of the stored energy, be provided with a warning device, in addition to a pressure gauge, where fitted, giving an optical or acoustic signal when the stored energy, in any part of the system, falls to a value at which without re-charging of the reservoir and irrespective of the load conditions of the vehicle, it is possible to apply the service brake control a fifth time after four full-stroke actuations and obtain the prescribed secondary braking performance (without faults in the service brake transmission and with the brakes adjusted as closely as possible). This warning device must be directly and permanently connected to the circuit. When the engine is

running under normal operating conditions and there are no faults in the braking system, as is the case in approval tests for this type, the warning device must give no signal except during the time required for charging the energy reservoir(s) after start-up of the engine. The red warning signal specified in paragraph 5.2.1.29.1.1. shall be used as the optical warning signal.

- 5.2.1.13.1.1. However, in the case of vehicles which are only considered to comply with the requirements of paragraph 5.2.1.5.1. of this Regulation by virtue of meeting the requirements of paragraph 1.2.2. of Part C of annex 7 to this Regulation, the warning device shall consist of an acoustic signal in addition to an optical signal. These devices need not operate simultaneously, provided that each of them meet the above requirements and the acoustic signal is not actuated before the optical signal. The red warning signal specified in paragraph 5.2.1.29.1.1. shall be used as the optical warning signal.
- 5.2.1.13.1.2. This acoustic device may be rendered inoperative while the handbrake is applied and/or, at the choice of the manufacturer, in the case of automatic transmission the selector is in the "Park" position.
- 5.2.1.14. Without prejudice to the requirements of paragraph 5.1.2.3. of this Regulation, where an auxiliary source of energy is essential to the functioning of a braking system, the reserve of energy must be such as to ensure that, if the engine stops or in the event of a failure of the means by which the energy source is driven, the braking performance remains adequate to bring the vehicle to a halt in the prescribed conditions. In addition, if the muscular effort applied by the driver to the parking braking system is reinforced by a servo device, the actuation of the parking braking system must be ensured in the event of a failure of the servo device, if necessary by using a reserve of energy independent of that normally supplying the servo device. This reserve of energy may be that intended for the service braking system.
- 5.2.1.15. In the case of a power-driven vehicle to which the coupling of a trailer equipped with a brake controlled by the driver of the towing vehicle is authorized, the service braking system of the towing vehicle must be equipped with a device so designed that in the event of failure of the trailer's braking system, or in the event of an interruption in the air supply pipe (or of such other type of connection as may be adopted) between the towing vehicle and its trailer, it shall still be possible to brake the towing vehicle with the effectiveness prescribed for secondary braking; it is accordingly prescribed, in particular, that this device shall be situated on the towing vehicle.
- 5.2.1.16. If the pneumatic/hydraulic auxiliary equipment must be supplied with energy in such a way that during its operation the prescribed deceleration values can be reached and that even in the event of damage to the source of energy the operation of the auxiliary equipment cannot cause the reserves of energy feeding the braking systems to fall below the level indicated in paragraph 5.2.1.13. above.
- 5.2.1.17. If the trailer is of category O₃ or O₄, the service braking system must be of the continuous or semi-continuous type.

- 5.2.1.18. In the case of a vehicle authorized to tow a trailer of category O₃ or O₄, its braking systems must satisfy the following conditions:
- 5.2.1.18.1. when the towing vehicle's secondary braking system comes into action, there must also be a graduated braking action in the trailer;
- 5.2.1.18.2. in the event of failure of the towing vehicle's service braking system, where that system consists of at least two independent parts, the part or parts not affected by the failure should be capable of partially or fully actuating the brakes of the trailer. It must be possible to graduate this braking action. If this operation is achieved by a valve which is normally at rest, then such a valve may only be incorporated if its correct functioning can easily be checked by the driver, either from within the cab or from outside the vehicle, without the use of tools;
- 5.2.1.18.3. in the event of a failure (e.g. breakage of or leak) in one of the pneumatic connecting lines, interruption or defect in the electric control line, it shall nevertheless be possible for the driver fully or partially to actuate the brakes of the trailer by means either of the service braking control or of the secondary braking control or of the parking braking control, unless the failure automatically causes the trailer to be braked with the performance prescribed in paragraph 3.3. of annex 4 to this Regulation.
- 5.2.1.18.4. the automatic braking in paragraph 5.2.1.18.3. above shall be considered to be met when the following conditions are fulfilled:
- 5.2.1.18.4.1. when the designated brake control of the controls mentioned in paragraph 5.2.1.18.3. above, is fully actuated, the pressure in the supply line must fall to 1.5 bar within the following two seconds;
- 5.2.1.18.4.2. when the supply line is evacuated at the rate of at least 1 bar per second the automatic braking of the trailer must start to operate before the pressure in the supply line falls to 2 bar.
- 5.2.1.18.5. in the event of a failure in one of the control lines connecting two vehicles equipped according to paragraph 5.1.3.1.2., the control line not affected by the failure shall automatically ensure the braking performance prescribed for the trailer in paragraph 3.1. of annex 4.
- 5.2.1.19. In the case of a power-driven vehicle equipped to draw a trailer with electrical braking system, according to paragraph 1.1. of annex 14 to this Regulation, the following requirements shall be met:
- 5.2.1.19.1. the power supply (generator and battery) of the power-driven vehicle shall have a sufficient capacity to provide the current for an electrical braking system. With the engine running at the idling speed recommended by the manufacturer and all electrical devices supplied by the manufacturer as standard equipment of the vehicle switched on, the voltage in the electrical lines shall at maximum current consumption of the electrical braking system (15 A) not fall below the value of 9.6 V measured at the connection. The electrical lines shall not be capable of short circuiting even when overloaded;

- 5.2.1.19.2. in the event of a failure in the towing vehicle's service braking system, where that system consists of at least two independent parts, the part or parts not affected by the failure should be capable of partially or fully actuating the brakes of the trailer;
- 5.2.1.19.3. the use of the stop-lamp switch and circuit for actuating the electrical braking system is permissible only if the actuating line is connected in parallel with the stop-lamp and the existing stop-lamp switch and circuit are capable of taking the extra load.
- 5.2.1.20. In the case of a pneumatic service braking system comprising two or more independent sections, any leakage between those sections at or downstream of the control shall be continuously vented to atmosphere.
- 5.2.1.21. In the case of a power-driven vehicle authorized to tow a trailer of categories O₃ or O₄, the service braking system of the trailer may only be operated in conjunction with the service, secondary or parking braking system of the towing vehicle.
- 5.2.1.22. Power-driven vehicles of categories M₂, M₃, N₂ and N₃ with not more than four axles shall be equipped with anti-lock systems of category 1 in accordance with annex 13 to this Regulation.
- 5.2.1.23. Power-driven vehicles of category M₁ equipped with temporary-use spare wheels/tyres shall satisfy the technical requirements of annex 3 to Regulation No. 64.
- 5.2.1.24. Power-driven vehicles authorized to tow a trailer equipped with an anti-lock system shall also be equipped with a special electrical connector, conforming to ISO/DIS 7638:1996 */ , for the electric control transmission and/or the anti-lock systems of trailers.
- 5.2.1.25. Additional requirements for electric vehicles of categories M₁, M₂, N₁ and category N₂ < 5 tonnes
- 5.2.1.25.1. Electric vehicles fitted with an electric regenerative braking system of category A
- 5.2.1.25.1.1. The electric regenerative braking shall only be actuated by the accelerator control and/or the gear selector neutral position for vehicles of category M₁ or N₁.
- 5.2.1.25.1.2. In addition, for vehicles of categories M₂ and N₂ (< 5 tonnes), the electric regenerative braking control can be a separate switch or lever.
- 5.2.1.25.2. Electric vehicles fitted with an electric regenerative braking system of category B
- 5.2.1.25.2.1. It shall not be possible to disconnect partially or totally one part of the service braking system other than by an automatic device.
- 5.2.1.25.2.2. The service braking system shall have only one control device.

*/ The ISO/DIS 7638:1996 connector may be used for 5 pin or 7 pin applications, as appropriate.

- 5.2.1.25.2.3. For electric vehicles fitted with an electric regenerative braking system of both categories, all the relevant prescriptions shall apply except paragraph 5.2.1.25.1.1.

In this case, the electric regenerative braking may be actuated by the accelerator control and/or the gear selector neutral position for vehicles of category M_1 or N_1 .

Additionally, the action on the service braking control must not reduce the above braking effect generated by the release of accelerator control.

- 5.2.1.25.2.4. The service braking system shall not be adversely affected by the disengagement of the motor(s) or by the gear ratio used.
- 5.2.1.25.2.5. If the operation of the electric component of braking is ensured by a relation established between the information coming from the control of the service brake and the braking force at the respective wheels, a failure of this relation leading to the modification of the braking distribution among the axles (annex 10 or 13, whichever is applicable) must be signalled to the driver by an optical warning signal at the latest at the moment when the control is actuated and this signal shall remain lit as long as this defect exists and that the vehicle control switch (key) is in the "ON" position.
- 5.2.1.25.3. The operation of the electric regenerative braking must not be adversely affected by magnetic or electric fields.
- 5.2.1.25.4. For vehicles equipped with an anti-lock device, the anti-lock device shall control the electric regenerative braking system.
- 5.2.1.26. Special additional requirements for the electric transmission of the parking braking system
- 5.2.1.26.1. In the case of a failure within the electric transmission, any unintended actuation of the parking braking system shall be prevented.
- 5.2.1.26.2. In the case of a break in the wiring within the electric control transmission, it shall remain possible to apply the parking braking system from the driver's seat and achieve the parking braking performance specified in paragraph 2.3.1. of annex 4 to this Regulation. It shall also be possible to release the parking braking system, if necessary by the use of an auxiliary release device carried/fitted on the vehicle. In the case of vehicles of categories M_1 and N_1 the engine/manual transmission or the automatic transmission (park position) may be used to achieve the above performance.
- 5.2.1.26.2.1. A break in the supply of electricity and/or in the wiring within the electric transmission of the parking braking system shall be signalled to the driver by the yellow warning signal specified in paragraph 5.2.1.29.1.2.
- 5.2.1.26.3. Auxiliary equipment may draw its energy from the energy reserve of the electric transmission of the parking braking system, provided that the actuation of the parking braking system will not be affected. In addition, where the energy reserve is also used by the service braking system, the requirements of paragraph 5.2.1.27.7. shall apply.
- 5.2.1.26.4. After the ignition/start switch which controls the electrical

energy for the braking equipment has been switched off and/or the key removed, it shall remain possible to apply the parking braking system, whereas releasing shall be prevented.

- 5.2.1.27. Special additional requirements for service braking systems with electric control transmission
- 5.2.1.27.1. With the parking brake released, the service braking system shall be able to generate a static total braking force at least equivalent to that produced during the Type-0 test, even when the ignition/start switch has been switched off and/or the key has been removed. In the case of power-driven vehicles authorized to tow trailers of category O₃ or O₄, such vehicles shall provide a full control signal for the service braking system of the trailer. It should be understood that sufficient energy is available in the energy transmission of the service braking system.
- 5.2.1.27.2. In the case of a single temporary failure (< 40 ms) within the electric control transmission (e.g. non-transmitted signal or data error) there shall be no distinguishable effect on the service braking performance.
- 5.2.1.27.3. A continuous failure (≥ 40 ms) within the electric control transmission 6/, excluding its energy reserve shall be indicated to the driver by the red or yellow warning signal specified in paragraphs 5.2.1.29.1.1. and 5.2.1.29.1.2., respectively, as appropriate. When the prescribed service braking performance can no longer be achieved (red warning signal), failures resulting from a loss of electrical continuity (eg. breakage, disconnection) shall be signalled to the driver as soon as they occur, and the prescribed residual braking performance shall be fulfilled by operating the service braking control in accordance with paragraph 2.4. of annex 4 to this Regulation. These requirements shall not be construed as a departure from the requirements concerning secondary braking.
- 5.2.1.27.4. A power-driven vehicle, electrically connected to a trailer via an electric control line, shall provide a clear warning to the driver whenever the trailer provides the failure information that the stored energy in any part of the service braking system on the trailer falls below the warning level, as specified in paragraph 5.2.2.16. below. A similar warning shall also be provided when a continuous failure (> 40 ms) within the electric control transmission of the trailer, excluding its energy reserve, precludes achievement of the prescribed service braking performance of the trailer, as specified in paragraph 5.2.2.15.2.1. below. The red warning signal specified in paragraph 5.2.1.29.2.1. shall be used for this purpose.
- 5.2.1.27.5. In the event of a failure of the energy source of the electric control transmission, starting from the nominal value of the energy level, the full control range of the service braking system shall be guaranteed after twenty consecutive full stroke actuations of the service braking control. During the test, the braking control shall be fully applied for 20 seconds and released for 5 seconds on each actuation. It should be understood that during the above test sufficient energy is available in the energy transmission to ensure full actuation of the service braking system. This requirement shall not be

6/ Until uniform test procedures have been agreed, the manufacturer shall provide the Technical Service with an analysis of potential failures within the control transmission and their effects. This information shall be subject to discussion and agreement between the Technical Service and the vehicle manufacturer.

construed as a departure from the requirements of annex 7.

- 5.2.1.27.6. When the battery voltage falls below a value nominated by the manufacturer at which the prescribed service braking performance can no longer be guaranteed and/or which precludes at least two independent service braking circuits from each achieving the prescribed secondary or residual braking performance, the red warning signal specified in paragraph 5.2.1.29.1.1. shall be activated. After the warning signal has been activated, it shall be possible to apply the service braking control and obtain at least the residual performance prescribed in paragraph 2.4. of annex 4 to this Regulation. It should be understood that sufficient energy is available in the energy transmission of the service braking system. This requirement shall not be construed as a departure from the requirement concerning secondary braking.
- 5.2.1.27.7. If the auxiliary equipment is supplied with energy from the electric control transmission, the supply of the energy shall be sufficient to fulfil the prescribed deceleration values when all the auxiliary equipment is functioning. During the test, the energy consumption of the trailer shall be simulated by a load of 400 W. With the engine running at a speed not greater than 80 per cent of the maximum power speed, the electric control transmission energy reserve shall not be discharged unless the prescribed deceleration values can be reached without the use of electrical energy. Compliance with this requirement may be demonstrated by calculation or by a practical test.
- 5.2.1.27.8. If the auxiliary equipment is supplied with energy from the electric control transmission, the following requirements shall be fulfilled.
- 5.2.1.27.8.1. In the event of a failure in the energy source, whilst the vehicle is in motion, the energy in the reservoir shall be sufficient to actuate the brakes when the control is applied.
- 5.2.1.27.8.2. In the event of a failure in the energy source, whilst the vehicle is stationary and the parking braking system applied, the energy in the reservoir shall be sufficient to actuate the lights even when the brakes are applied.
- 5.2.1.27.9. In the case of a failure in the electric control transmission of the service braking system of a towing vehicle equipped with an electric control line according to paragraph 5.1.3.1.2. or 5.1.3.1.3., the full actuation of the brakes of the trailer shall remain ensured.
- 5.2.1.27.10. In the case of a failure in the electric control transmission of a trailer, electrically connected via an electric control line only, according to paragraph 5.1.3.1.3., a full actuation of the brakes of the trailer shall be ensured by pressure drop in the pneumatic supply line.
- 5.2.1.28. Special requirements for coupling force control
- 5.2.1.28.1. Coupling force control shall only be permitted in the towing vehicle.
- 5.2.1.28.2. The action of the coupling force control shall be to reduce the difference between the dynamic braking rates of towing and towed vehicles.

- 5.2.1.28.2.1. The coupling force control may control the braking rate T_M/P_M , the pneumatic control line pressure at the coupling head p_m and/or the corresponding electric brake demand value for the trailer. In the case of a towing vehicle equipped with two control lines according to paragraph 5.1.3.1.2., both control signals have to correspond to each other.
- 5.2.1.28.2.2. The coupling force control shall not prevent the maximum possible braking pressure(s) from being applied.
- 5.2.1.28.3. The vehicle shall fulfil the laden compatibility requirements of annex 10, but to achieve the objectives of paragraph 5.2.1.28.2. the vehicle may deviate from these requirements when the coupling force control is in operation.
- 5.2.1.28.4. A coupling force control failure shall be detected and indicated to the driver by a yellow warning signal such as that specified in paragraph 5.2.1.29.1.2. In the event of a failure the relevant requirements of annex 10 shall be fulfilled.
- 5.2.1.28.5. Compensation by the coupling force control system shall be indicated by means of the yellow warning signal specified in paragraph 5.2.1.29.1.2. if this compensation exceeds ± 1.5 bar away from the nominal demand value defined in paragraph 2.27.3. up to a limit, in p_m , of 6.5 bar (or the equivalent digital demand). Above the level of 6.5 bar the warning shall be given if the compensation causes the operating point to lie outside the laden compatibility band as specified in annex 10 for the motor vehicle.

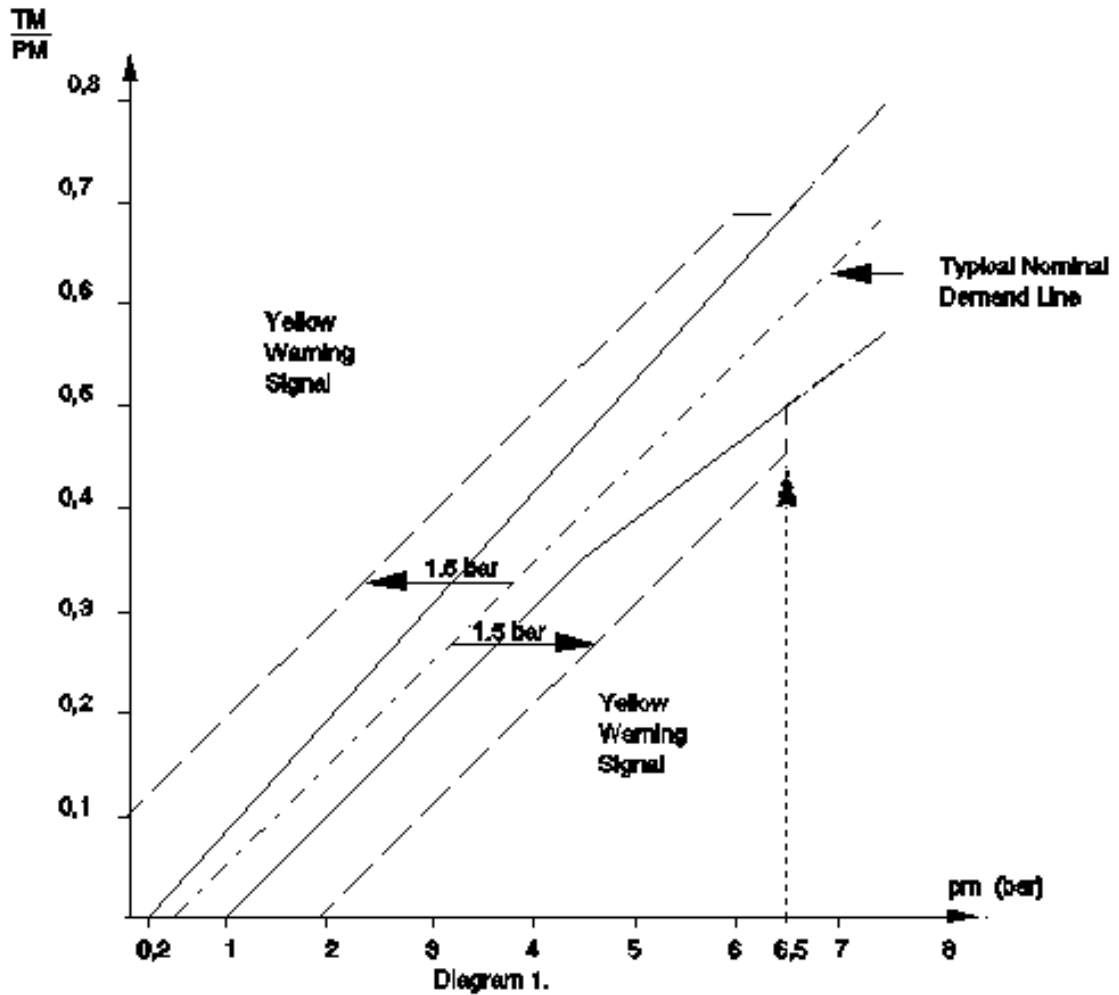

Towing Vehicles for Trailers (except semi-trailers)

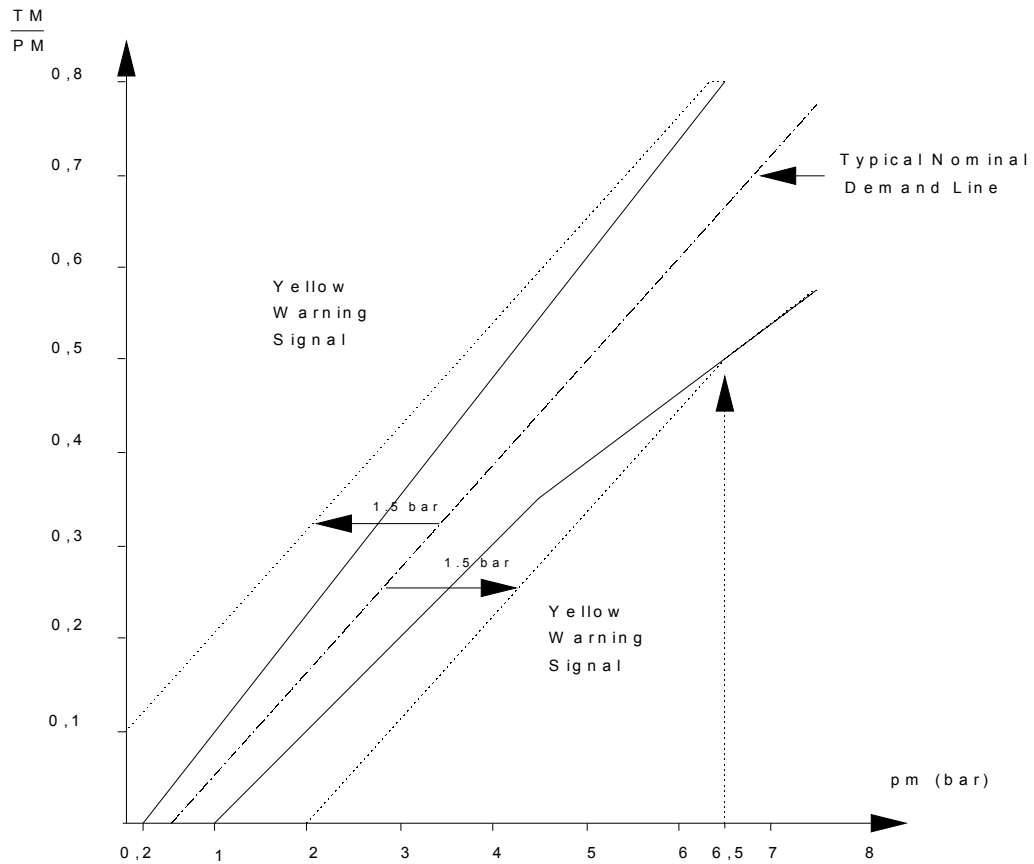

D I A G R A M 2 .
 T r a c t i v e U n i t s f o r S e m i - t r a i l e r s .

5.
 2.
 1.
 28
 .6
 .
 A

coupling force control system shall control only the coupling forces generated by the service braking system of the motor vehicle and the trailer, excluding endurance braking systems. Coupling forces resulting from the performance of endurance braking systems shall not be compensated by the service braking system. It is considered that endurance braking systems are not part of the service braking systems.

5.2.1.29. Brake failure and defect warning signals (general requirements).

5.2.1.29.1. Power-driven vehicles shall be capable of providing optical brake failure and defect warning signals, as follows:

5.2.1.29.1.1. a red warning signal, indicating a failure within the vehicle braking equipment which precludes achievement of the prescribed service braking performance and/or which precludes the functioning of at least one of two independent service braking circuits.

5.2.1.29.1.2. where applicable, a yellow warning signal indicating an electrically detected defect within the vehicle braking equipment, which is not indicated by the red warning signal described in paragraph 5.2.1.29.1.1. above.

- 5.2.1.29.2. With the exception of vehicles of categories M_1 and N_1 , power-driven vehicles equipped with an electric control line and/or authorised to tow a trailer equipped with electric control transmission and/or an anti-lock braking system, with the exception of vehicles of categories M_1 and N_1 , shall be capable of providing a separate yellow warning signal to indicate a defect within the anti-lock braking system and/or electric control transmission of the braking equipment of the trailer. The signal shall be activated from the trailer via pin 5 of the electrical connector conforming to ISO/DIS 7638:1996. */ This warning signal shall not light up when coupled to a trailer without an electric control line and/or electric control transmission and/or an anti-lock braking system or when no trailer is coupled. This function shall be automatic.
- 5.2.1.29.2.1. In the case of a power-driven vehicle equipped with an electric control line, when electrically connected to a trailer with an electric control line, the red warning signal specified in paragraph 5.2.1.29.1.1. above shall also be used to indicate certain specified failures within the braking equipment of the trailer, whenever the trailer provides corresponding failure information via the data communication part of the electric control line. This indication shall be in addition to the yellow warning signal specified in paragraph 5.2.1.29.2. above. Alternatively, instead of utilizing the red warning signal specified in paragraph 5.2.1.29.1.1. and the accompanying yellow warning signal above, a separate red warning signal may be provided in the towing vehicle to indicate such a failure within the braking equipment of the trailer.
- 5.2.1.29.3. The warning signals shall be visible, even by daylight; the satisfactory condition of the signals shall be easily verifiable by the driver from the driver's seat; the failure of a component of the warning devices shall not entail any loss of the braking system's performance.
- 5.2.1.29.4. A specified failure or defect shall be signalled to the driver by the above-mentioned warning signal(s) not later than on actuation of the service braking control. The warning signal(s) shall remain displayed as long as the failure/defect persists and the ignition (start) switch is in the "ON" (run) position.
- 5.2.1.29.5. The warning signal(s) mentioned above shall light up when the electrical equipment of the vehicle (and the braking system) is energized. With the vehicle stationary, the braking system shall verify that none of the specified failures or defects are present before extinguishing the signals. Specified failures or defects which should activate the warning signals mentioned above, but which are not detected under static conditions, shall be stored upon detection and be displayed at start-up and at all times when the ignition (start) switch is in the "on" (run) position, as long as the failure or defect persists.
- 5.2.2. **Vehicles of category O**
- 5.2.2.1. Trailers of category O_1 need not be equipped with a service braking system; however, if a trailer of this category is equipped with a service braking system, it must satisfy the same

*/ The ISO/DIS 7638:1996 connector may be used for 5 pin or 7 pin applications, as appropriate.

requirements as a trailer of category O₂.

- 5.2.2.2. Trailers of category O₂ must be equipped with a service braking system either of the continuous or semi-continuous or of the inertia (overrun) type. The latter type shall be authorized only for trailers other than semi-trailers. However, electrical braking systems conforming to the requirements of annex 14 to this Regulation shall be permitted.
- 5.2.2.3. Trailers of categories O₃ and O₄ must be equipped with a service braking system of the continuous or semi-continuous type.
- 5.2.2.4. The service braking system:
- 5.2.2.4.1. shall act on all the wheels of the vehicle;
- 5.2.2.4.2. shall distribute its action appropriately among the axles;
- 5.2.2.4.3. shall contain in at least one of the air reservoirs a device for draining and exhausting in an adequate and easily accessible position.
- 5.2.2.5. The action of the service braking system shall be distributed between the wheels of one and the same axle symmetrically in relation to the longitudinal median plane of the vehicle. Compensation and functions such as anti-lock, which may cause deviations from this symmetrical distribution, and functions, which may cause application of the brakes not directly controlled by the driver, shall be declared. 7/
- 5.2.2.5.1. Compensation by the electric control transmission for deterioration or defect within the braking system shall be indicated to the driver by means of the separate yellow optical warning signal specified in paragraph 5.2.1.29.2. This requirement shall apply for all conditions of loading when compensation exceeds the following limits:
- 5.2.2.5.1.1. a difference in transverse braking pressures on any axle:
- (a) of 25 per cent of the higher value for vehicle decelerations $\geq 2\text{m/sec}^2$,
- (b) a value corresponding to 25 per cent at 2m/sec^2 for decelerations below this rate.
- 5.2.2.5.1.2. an individual compensating value on any axle:
- (a) > 50 per cent of the nominal value for vehicle decelerations $\geq 2\text{ m/s}^2$,
- (b) a value corresponding to 50 per cent of the nominal value at 2m/s^2 for decelerations below this rate.
- 5.2.2.5.2. Compensation as defined above, is permitted only when the initial brake application is made at vehicle speeds

7/ Adequate performance specifications and the associated test procedures shall be presented by the manufacturer and shall be subject to discussion and agreement by the Technical Service (unless already covered by the present Regulation). For this purpose, the manufacturer shall provide documentation which covers: system layout, description of functions and safety concept.

greater than 10 km/h.

- 5.2.2.6. Malfunctions of the electric control transmission shall not apply the brakes contrary to the driver's intentions.
- 5.2.2.7. The braking surfaces required to attain the prescribed degree of effectiveness must be in constant connection with the wheels, either rigidly or through components not liable to failure.
- 5.2.2.8. Wear of the brakes must be capable of being easily taken up by means of a system of manual or automatic adjustment. In addition, the control and the components of the transmission and of the brakes must possess a reserve of travel and, if necessary, suitable means of compensation such that, when the brakes become heated, or the brake linings have reached a certain degree of wear, effective braking is ensured without immediate adjustment being necessary.
- 5.2.2.8.1. Wear adjustment shall be automatic for the service brakes. However, the fitting of automatic adjustment devices is optional for vehicles of categories O₁ and O₂. Automatic wear adjustment devices shall be such that after heating followed by cooling of the brakes, effective braking is still ensured. In particular the vehicle shall remain capable of normal running after the

tests conducted in accordance with paragraph 1.5. (Type-I test) and paragraph 1.6. (Type-II test) of annex 4 to this Regulation. 8/

- 5.2.2.8.2. It shall be possible to easily check this wear on service brake linings from the outside or underside of the vehicle utilizing only the tools or equipment normally supplied with the vehicle, for instance by the provision of appropriate inspection holes or by some other means.
- 5.2.2.9. The braking systems must be such that the trailer is stopped automatically if the coupling separates while the trailer is in motion. However, this provision shall not apply to trailers with a maximum mass not exceeding 1.5 tonnes, on the condition that the trailers are equipped with, in addition to the coupling device, a secondary coupling (chain, wire rope, etc.) capable, in the event of separation of the main coupling, of preventing the drawbar from touching the ground and providing some residual steering action on the trailer.
- 5.2.2.10. On every trailer which is required to be equipped with a service braking system, parking braking must be assured even when the trailer is separated from the towing vehicle. The parking braking device must be capable of being actuated by a person standing on the ground; however, in the case of a trailer used for the carriage of passengers, this brake must be capable of being actuated from inside the trailer.
- 5.2.2.11. If the trailer is fitted with a device enabling compressed-air actuation of the braking system other than the parking braking system to be cut out, the first-mentioned system must be so designed and constructed that it is positively restored to the position of rest not later than on resumption of the supply of compressed-air to the trailer.
- 5.2.2.12. Trailers of categories O₃ and O₄ shall satisfy the conditions specified in paragraph 5.2.1.18.4.2. An easily accessible pressure test connection is required downstream of the coupling head of the control line.
- 5.2.2.12.1. In the case of trailers equipped with an electric control line and electrically connected to a towing vehicle with an electric control line the automatic braking action specified in paragraph 5.2.1.18.4.2. may be suppressed as long as the pressure in the compressed air reservoirs of the trailer is sufficient to ensure the braking performance specified in paragraph 3.3 of annex 4 to this Regulation.
- 5.2.2.13. Trailers of categories O₃ and O₄ shall be equipped with anti-lock systems in accordance with the requirements of annex 13 to this Regulation.
- 5.2.2.14. The auxiliary equipment must be supplied with energy in such a way that during its operation the service brake energy storage device(s) shall be maintained at a pressure of at least 80 per

8/ Until uniform test procedures have been agreed, there is no need to repeat the above-defined tests with automatic brake wear adjustment devices, if the Type-I and Type-II tests have been carried out according to the procedure in annex 11 to this Regulation, with a manual or automatic brake wear adjustment device.

cent of the minimum towing vehicle supply pressure as defined in paragraph 3.1.3.2. of annex 10 to this Regulation.

- 5.2.2.14.1. In the event of breakage or leakage from the auxiliary equipment or any associated pipes, the sum of forces exerted at the periphery of the braked wheels shall be at least 80 per cent of the value prescribed for the trailer concerned in paragraph 3.1.2.1. of annex 4 to this Regulation. However, where such brakeage or leakage affects the control signal to a special device as referred to in paragraph 6 of annex 10 to this Regulation, the performance requirements of that paragraph shall apply.
- 5.2.2.15. Special additional requirements for service braking systems with electric control transmission
- 5.2.2.15.1. In the case of a single temporary failure (< 40 ms) within the electric control transmission (e.g. non-transmitted signal or data error) there shall be no distinguishable effect on the service braking performance.
- 5.2.2.15.2. In the case of a continuous failure (\geq 40 ms) within the electric control transmission (e.g. breakage, disconnection), a braking performance of at least 30 per cent of the prescribed performance for the service braking system of the relevant trailer shall be maintained.
- 5.2.2.15.2.1. A continuous failure (> 40 ms) within the electric control transmission of the trailer, excluding its energy reserve, shall be indicated to the driver by the separate warning signal specified in paragraph 5.2.1.29.2. via pin 5 of the electrical connector conforming to ISO/DIS 7638:1996. */ In addition, trailers equipped with an electric control line, when electrically connected to a towing vehicle with an electric control line, shall provide the failure information for activation of the red warning signal specified in

*/ The ISO/DIS 7638:1996 connector may be used for 5 pin or 7 pin applications, as appropriate.

paragraph 5.2.1.29.2.1. via the data communication part of the electric control line, when the prescribed service braking performance of the trailer can no longer be ensured.

- 5.2.2.16. When the stored energy in any part of the service braking system of a trailer equipped with an electric control line and electrically connected to a towing vehicle with an electronic control line falls to the value determined in accordance with paragraph 5.2.2.16.1. below, a warning shall be provided to the driver of the towing vehicle. The warning shall be provided by activation of the red signal specified in paragraph 5.2.1.29.2.1. and the trailer shall provide the failure information via the data communication part of the electric control line. The separate yellow warning signal specified in paragraph 5.2.1.29.2. shall also be activated via pin 5 of the electrical connector conforming to ISO/DIS 7638:1996 */, to indicate to the driver that the low-energy situation is on the trailer.
- 5.2.2.16.1. The low energy value referred to in paragraph 5.2.2.16. above shall be that at which, without re-charging of the energy reservoir and irrespective of the load condition of the trailer, it is not possible to apply the service braking control a fifth time after four full-stroke actuations and obtain at least 50 per cent of the prescribed performance of the service braking system of the relevant trailer.
- 5.2.2.17. Trailers equipped with an electric control line and O₃ and O₄ category trailers equipped with an anti-lock system, shall be fitted with a special electrical connector for the braking system and/or anti-lock system, conforming to ISO/DIS 7638:1996. 9/*/ Failure warning signals required from the trailer by this Regulation shall be activated via the above connector. The warning signal shall be displayed when the electric part of the braking equipment of the trailer is energized and the braking system shall verify that none of the defects which are required to be indicated by this signal are present before extinguishing the signal.
- 5.2.2.18. In addition to the requirements specified in paragraph 5.1.3.6., the electrical power supplied by the ISO/DIS 7638:1996 **/ connector may be used for non-braking systems/functions provided that the braking system is protected from an overload external to the braking system. This protection shall be a function of the braking system.

9/ The wiring specifications of ISO/DIS 7638:1996 for the trailer not equipped with an electric control transmission may be reduced if the trailer is installed with its own independent fuse. The rating of the fuse shall be such that the current rating of the conductors is not exceeded.

*/ The ISO/DIS 7638:1996 connector may be used for 5 pin or 7 pin applications, as appropriate.

**/ The ISO/DIS 7638:1996 connector may be used for 5 pin or 7 pin applications, as appropriate.

5.2.2.19. In the case of a failure in one of the control lines connecting two vehicle equipped according to paragraph 5.1.3.1.2. the trailer shall use the control line not affected by the failure to ensure, automatically, the braking performance prescribed for the trailer in paragraph 3.1. of annex 4.

5.2.2.20. When the supply voltage to the trailer falls below a value nominated by the manufacturer at which the prescribed service braking performance can no longer be guaranteed, the separate yellow warning signal specified in paragraph 5.2.1.29.2. shall be activated via pin 5 of the ISO/DIS 7638:1996 */ connector. In addition, trailers equipped with an electrical control line, when electrically connected to a towing vehicle with an electric control line, shall provide the failure information for actuation of the red warning signal specified in paragraph 5.2.1.29.2.1. via the data communication part of the electric control line.

6. TESTS

Braking tests which the vehicles submitted for approval are required to undergo, and the braking performance required, are described in annex 4 to this Regulation.

7. MODIFICATION OF VEHICLE TYPE OR BRAKING SYSTEM AND EXTENSION OF APPROVAL

7.1. Every modification of the vehicle type or of its braking equipment with regard to the characteristics in annex 2 to this Regulation shall be notified to the administrative department which approved the vehicle type. That department may then either:

7.1.1. consider that the modifications made are unlikely to have an appreciable adverse effect and that in any case the vehicle still meets the requirements; or

7.1.2. require a further report from the Technical Service responsible for carrying out the tests.

7.2. Confirmation or refusal of approval, specifying the alterations, shall be communicated by the procedure specified in paragraph 4.3. above, to the Parties to the Agreement which apply this Regulation.

7.3. The competent authority issuing the extension of approval shall assign a series number to each communication form drawn up for such an extension and inform thereof the other Contracting Parties to the 1958 Agreement by means of a communication form conforming to the model in annex 2 to this Regulation.

8. CONFORMITY OF PRODUCTION

8.1. A vehicle approved to this Regulation shall be so manufactured as to conform to the type approved by meeting the requirements set forth in paragraph 5 above.

8.2. In order to verify that the requirements of paragraph 8.1. above, are met, suitable controls of the production shall be carried out.

8.3. The holder of the approval shall in particular:

8.3.1. ensure existence of procedures for the effective control of the

quality of products;

- 8.3.2. have access to the control equipment necessary for checking the conformity to each approved type;
- 8.3.3. ensure that data of test results are recorded and that annexed documents shall remain available for a period to be determined in accordance with the Administrative Service;
- 8.3.4. analyse the results of each type of test, in order to verify and ensure the stability of the product characteristics making allowance for variation of an industrial production;
- 8.3.5. ensure that for each type of product the tests, or some of them, prescribed in this Regulation are carried out;
- 8.3.6. ensure that any samples or test pieces giving evidence of non-conformity with the type of test considered shall give rise to another sampling and another test. All the necessary steps shall be taken to re-establish the conformity of the corresponding production.
- 8.4. The competent authority which has granted type approval may at any time verify the conformity control methods applicable to each production unit.
 - 8.4.1. At every inspection, the test books and production survey records shall be presented to the visiting inspector.
 - 8.4.2. The inspector may take samples at random which will be tested in the manufacturer's laboratory. The minimum number of samples may be determined according to the results of the manufacturer's own verification.
 - 8.4.3. When the quality level appears unsatisfactory or when it seems necessary to verify the validity of the tests carried out in application of paragraph 8.4.2. above, the inspector shall select samples to be sent to the Technical Service which has conducted the type approval tests.
 - 8.4.4. The competent authority may carry out any test prescribed in this Regulation.
 - 8.4.5. The normal frequency of inspections by the competent authority shall be one every two years. If unsatisfactory results are recorded during one of these visits, the competent authority shall ensure that all necessary steps are taken to re-establish the conformity of production as rapidly as possible.
9. PENALTIES FOR NON-CONFORMITY OF PRODUCTION
 - 9.1. The approval granted in respect of a vehicle type pursuant to this Regulation may be withdrawn if the requirements laid down in paragraph 8.1. above are not complied with.
 - 9.2. If a Contracting Party to the Agreement which applies this Regulation withdraws an approval it has previously granted, it shall forthwith so notify the other Contracting Parties applying this Regulation by means of a copy of a communication form conforming to the model in annex 2 to this Regulation.
10. PRODUCTION DEFINITELY DISCONTINUED

If the holder of the approval completely ceases to manufacture a type of vehicle approved in accordance with this Regulation, he shall so inform the authority which granted the approval. Upon receiving the relevant communication, that authority shall inform thereof the other Contracting Parties to the Agreement applying this Regulation by means a communication form conforming to the model in annex 2 to this Regulation.

11. NAMES AND ADDRESSES OF THE TECHNICAL SERVICES CONDUCTING APPROVAL TESTS AND OF ADMINISTRATIVE DEPARTMENTS

The Parties to the Agreement applying this Regulation shall communicate to the United Nations Secretariat the names and addresses of the Technical Services responsible for conducting approval tests and of the administrative departments which grant approval and to which forms certifying approval or extension or refusal or withdrawal of approval, issued in other countries, are to be sent.

12. TRANSITIONAL PROVISIONS

12.1. General

12.1.1. As from the official date of entry into force of the 09 series of amendments, no Contracting Party applying this Regulation shall refuse to grant approval under this Regulation as amended by the 09 series of amendments.

12.1.2. New type approvals

12.1.2.1. Subject to the provisions of paragraph 12.2., as from 1 October 1996 Contracting Parties applying this Regulation shall grant approvals only if the vehicle type to be approved meets the requirements of this Regulation as amended by the 08 or 09 series of amendments.

12.1.2.2. Subject to the provisions of paragraph 12.2., as from 1 October 1998 Contracting Parties applying this Regulation shall grant approvals only if the vehicle type to be approved meets the requirements of this Regulation as amended by the 09 series of amendments.

12.1.3. Limit of validity of old type approvals

12.1.3.1. Subject to the provisions of paragraphs 12.1.3.3. and 12.2., approvals granted to this Regulation, as amended by the 06 or 07 series of amendments, shall cease to be valid on 1 October 1998 unless the Contracting Party which granted the approval notifies the other Contracting Parties applying this Regulation that the vehicle type approved meets the requirements of this Regulation as amended by the 08 or 09 series of amendments.

12.1.3.2. Subject to the provisions of paragraphs 12.1.3.3. and 12.2., approvals granted to this Regulation, as amended by the 08 series of amendments, shall cease to be valid on 1 October 2000 unless the Contracting Party which granted the approval notifies the other Contracting Parties applying this Regulation that the vehicle type approved meets the requirements of this Regulation as amended by the 09 series of amendments.

12.1.3.3. For vehicles of category M₁ and N₁, approvals granted to the

06 series of amendments to this Regulation before 1 July 1995 and any extensions of approvals issued subsequently shall remain valid until 1 April 2001. However this derogation does not extend to the requirements contained in paragraph 5.1.1.3. of this Regulation which shall apply to all new vehicles from 1 October 1998.

12.2. Anti-lock braking devices.

In place of the dates specified in paragraphs 12.1.2. and 12.1.3., the requirement for anti-lock braking devices mentioned in paragraphs 5.2.1.22. and 5.2.2.13., as amended by the 08 series of amendments, shall be applied as follows:

Vehicle category	New type approvals (paragraph 12.1.2.)	Limit of validity of old type approvals (paragraph 12.1.3.)
N ₃	1 October 1996	1 October 1998
M ₂ , M ₃ , N ₂ > 7,5 tonnes maximum mass O ₃ > 5 tonnes maximum mass	1 April 1998	1 April 2000
N ₂ ≤ 7,5 tonnes maximum mass O ₃ ≤ 5 tonnes maximum mass	1 April 1999	1 April 2001

12.3. Method of selection of the low adhesion surface for anti-lock testing

By way of derogation, Contracting Parties may grant approvals to this Regulation, as amended by the 08 or 09 series of amendments, before 1 January 1998, even if the requirements of annex 13 - appendix 4 to this Regulation are not fulfilled.

Annex 1

BRAKING EQUIPMENT, DEVICES, METHODS AND CONDITIONS NOT COVERED
BY THIS REGULATION

1. Method of measuring reaction ("response") times in brakes other than compressed-air brakes.
-

Annex 2

COMMUNICATION */

(maximum format: A4 (210 x 297 mm))

issued by: Name of administration:

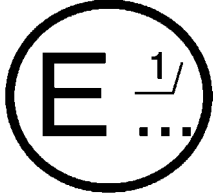

concerning: 2/ APPROVAL GRANTED
 APPROVAL EXTENDED
 APPROVAL REFUSED
 APPROVAL WITHDRAWN
 PRODUCTION DEFINITELY DISCONTINUED

of a type of vehicle with regard to braking pursuant to Regulation No. 13.

Approval No.:.....

Extension No.:.....

1. Trade name or mark of the vehicle:
2. Vehicle category:
3. Vehicle type:
4. Manufacturer's name and address :

5. If applicable, name and address of manufacturer's representative:

6. Mass of vehicle:
 - 6.1. Maximum mass of vehicle:
 - 6.2. Minimum mass of vehicle:
7. Distribution of mass of each axle (maximum value):
8. Make and type of brake linings:
 - 8.1. Brake linings tested to all relevant prescriptions of annex 4 . . .
 - 8.2. Alternative brake linings tested in annex 15
9. In the case of a power-driven vehicle:
 - 9.1. Engine type:
 - 9.2. Number and ratios of gears:
 - 9.3. Final drive ratio(s):
 - 9.4. If applicable, 2/ maximum mass of trailer which may be coupled:
 - 9.4.1. Full trailer:

- 9.4.2. Semi-trailer:
- 9.4.3. Centre-axle trailer
(indicate also the maximum ratio of the coupling overhang 3/ to the wheelbase):
- 9.4.4. Unbraked trailer:
- 9.4.5. Maximum mass of combination:
10. Tyre dimensions:
- 10.1. Temporary-use spare wheel/tyre dimensions:
- 10.2. Vehicle meets the technical requirements of annex 3 to Regulation No. 64: Yes/No 2/
11. Number and arrangement of axles:
12. Brief description of braking equipment:
.
13. Mass of vehicle when tested:

	Unladen [kg]	Laden [kg]
king pin/supporting load <u>4/</u>		
axle No. 1		
axle No. 2		
axle No. 3		
axle No. 4		
Total		

14. Results of the tests and vehicle characteristics

TEST RESULTS		Test speed [km/h]	Measured performance	Measured force applied to control [daN]
14.1. Type-0 tests, engine disconnected	service braking			
	secondary braking			
14.2. Type-0 tests, engine connected:	service braking in accordance with paragraph 2.1.1. of annex 4			
14.3. Type-I tests:	with repeated braking <u>5/</u>			
	with continuous braking <u>6/</u>			

14.4.	Type-II or IIA <u>2/</u> tests, as appropriate:	service braking			
14.5.	Type-III test <u>7/</u>				

- 14.6. Braking system(s) used during the Type-II/IIA 2/ test:
- 14.7. Reaction time and dimensions of flexible pipes:
- 14.7.1. Reaction time at the brake actuator: s
- 14.7.2. Reaction time at the control line coupling head: s
- 14.7.3. Flexible pipes of tractors for semi-trailers:
length (m):
internal diameter (mm):
- 14.8. Information required under paragraph 7.3. of annex 10 to this Regulation.
- 14.9. Vehicle is/is not 2/ equipped to tow a trailer with electrical braking systems
- 14.10. Vehicle is/is not 2/ equipped with an anti-lock system
- 14.10.1. The vehicle fulfils the requirements of annex 13: YES/NO 2/
- 14.10.2. Category of anti-lock system: category 1/2/3 2/ 5/
category A/B 2/ 6/
- 14.10.3. Vehicle is/is not 2/ equipped to tow trailers equipped with anti-lock systems
- 14.10.4. In case of trailers: Vehicle may/may not 2/ be operated in combination with a power-driven vehicle not equipped with the special connector conforming to ISO standard 7638:1985 8/
- 14.11. The vehicle is subject to the requirements of annex 5 (ADR): YES/NO 2/
- 14.11.1. The vehicle fulfils the endurance braking performance requirements according to the Type-IIA test up to a total maximum mass of tonnes: YES/NO 2/
- 14.11.2. The power-driven vehicle is fitted with a control device for the endurance braking system on the trailer: YES/NO 2/
- 14.11.3. In the case of trailers, the vehicle is equipped with an endurance braking system: YES/NO 2/
- 14.12. Vehicle is equipped with a control line(s) according to paragraphs 5.1.3.1.1./5.1.3.1.2./5.1.3.1.3. 2/
15. Vehicle submitted for approval on
16. Technical Service responsible for conducting approval tests
17. Date of report issued by that service

18. Number of report issued by that service
19. Approval granted/refused/extended/withdrawn 2/
20. Position of approval mark on the vehicle
21. Place
22. Date
23. Signature
24. The summary referred to in paragraph 4.3. of this Regulation is annexed to this communication.

*/ At the request of (an) applicant(s) for Regulation No. 90 approval, the information shall be provided by the Type Approval Authority as contained in appendix 1 to this annex. However, this information shall not be provided for purposes other than Regulation No. 90 approvals.

1/ Distinguishing number of the country which has granted/extended/refused/withdrawn approval (see approval provisions in the Regulation).

2/ Strike out what does not apply.

3/ "Coupling overhang" is the horizontal distance between the coupling for centre-axle trailers and the centreline of the rear axle(s).

4/ In the case of a semi-trailer or a centre-axle trailer, enter the mass corresponding to the load on the coupling device.

5/ Applies only to vehicles of categories M_1 , M_2 , M_3 , N_1 , N_2 and N_3 .

6/ Applies only to vehicles of categories O_2 and O_3 .

7/ Applies only to vehicles of category O_4 .

8/ In accordance with paragraph 4.4. of annex 13 to this Regulation.

Annex 2 - Appendix 1

LIST OF VEHICLE DATA FOR THE PURPOSE OF REGULATION No. 90 APPROVALS

1. Description of the vehicle type
- 1.1. Trade name or mark of the vehicle, if available
- 1.2. Vehicle category
- 1.3. Vehicle type according to Regulation No. 13 approval
.
- 1.4. Models or trade names of vehicles constituting the vehicle type, if
available
.
- 1.5. Manufacturer's name and address
2. Make and type of brake linings
- 2.1. Brake linings tested to all relevant prescriptions of annex 4 . . .
.
- 2.2. Brake linings tested to annex 15
3. Minimum mass of vehicle
- 3.1. Distribution of mass of each axle (maximum value)
.
4. Maximum mass of vehicle
- 4.1. Distribution of mass of each axle (maximum value)
.
5. Maximum vehicle speed
6. Tyre and wheel dimensions
7. Brake circuit configuration (e.g. front/rear or diagonal split) . .
.
8. Declaration of which is the secondary braking system
.
9. Specifications of brake valves (if applicable)
.
- 9.1. Adjustment specifications of the load sensing valve
.
- 9.2. Setting of pressure valve
10. Designed brake force distribution
11. Specification of brake
- 11.1. Disc brake type (e.g. number of pistons with diameter(s), ventilated
or solid disc)
- 11.2. Drum brake type (e.g. duo servo, with piston size and drum
dimensions)
- 11.3. In the case of compressed air brake systems, e.g. type and size of
chambers, levers, etc.
12. Master cylinder type and size

13. Booster type and size

Annex 3

ARRANGEMENTS OF APPROVAL MARKS

Model A

(See paragraph 4.4. of this Regulation)

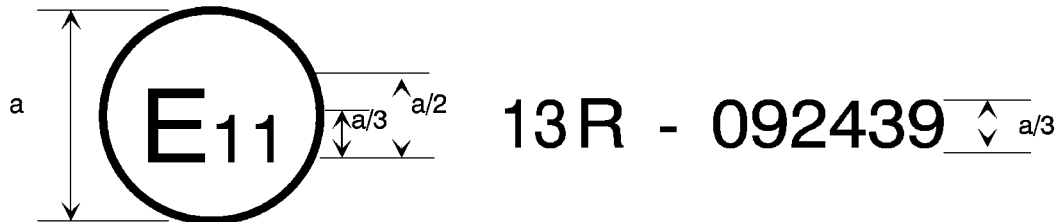

a = 8 mm min.

The above approval mark affixed to a vehicle shows that the vehicle type concerned has, with regard to braking, been approved in the United Kingdom (E 11) pursuant to Regulation No. 13 under approval number 092439. This number indicates that the approval was given in accordance with the requirements of Regulation No. 13 with the 09 series of amendments incorporated. For vehicles of categories M₂ and M₃, this mark means that that type of vehicle has undergone the Type-II test.

Model B

(See paragraph 4.5. of this Regulation)

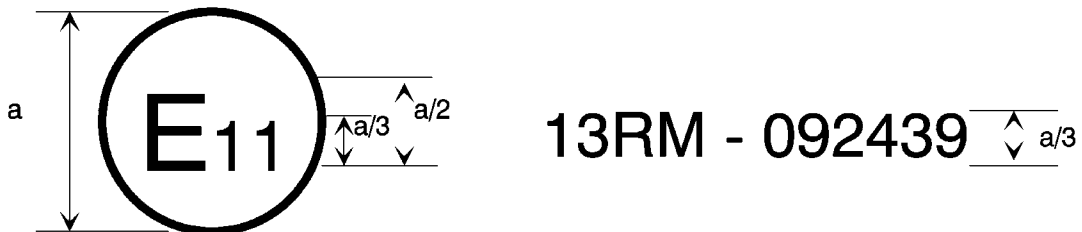

a = 8 mm min.

The above approval mark affixed to a vehicle shows that the vehicle type concerned has, with regard to braking, been approved in the United Kingdom (E 11) pursuant to Regulation No. 13. For vehicles of categories M₂ and M₃, this mark means that the type of vehicle has undergone the Type-IIA test.

Model C

(See paragraph 4.6. of this Regulation)

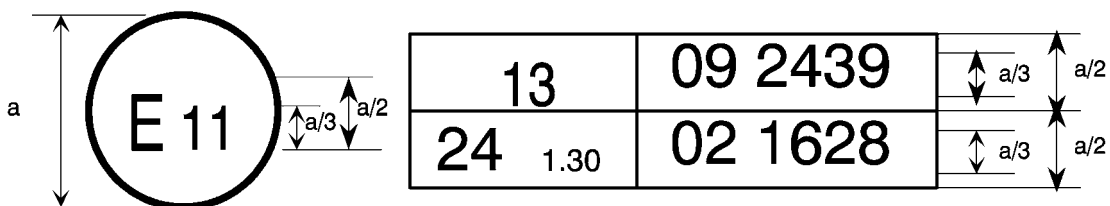

a = 8mm min

The above approval mark affixed to a vehicle shows that the vehicle type concerned has been approved in the United Kingdom (E 11) pursuant to Regulations Nos. 13 and 24 1/. (In the case of the latter Regulation the corrected absorption coefficient is 1.30 m⁻¹.)

1/ This number is given merely as an example.

Annex 4

BRAKING TESTS AND PERFORMANCE OF BRAKING SYSTEMS

1. BRAKING TESTS

1.1. **General**

1.1.1. The performance prescribed for braking systems is based on the stopping distance and/or the mean fully developed deceleration. The performance of a braking system shall be determined by measuring the stopping distance in relation to the initial speed of the vehicle and/or by measuring the mean fully developed deceleration during the test.

1.1.2. The stopping distance shall be the distance covered by the vehicle from the moment when the driver begins to actuate the control of the braking system until the moment when the vehicle stops; the initial speed shall be the speed at the moment when the driver begins to actuate the control of the braking system; the initial speed shall not be less than 98 per cent of the prescribed speed for the test in question.

The mean fully developed deceleration (d_m) shall be calculated as the deceleration averaged with respect to distance over the interval v_b to v_e , according to the following formula:

$$d_m = \frac{v_b^2 - v_e^2}{25.92 (s_e - s_b)} \quad [m/s^2]$$

where:

v_o = initial vehicle speed in km/h,

v_b = vehicle speed at 0.8 v_o in km/h,

v_e = vehicle speed at 0.1 v_o in km/h,

s_b = distance travelled between v_o and v_b in metres,

s_e = distance travelled between v_o and v_e in metres.

The speed and the distance shall be determined using instrumentation having an accuracy of ± 1 per cent at the prescribed speed for the test. The mean fully developed deceleration may be determined by other methods than the measurement of speed and distance; in this case, the accuracy of the mean fully developed deceleration shall be within ± 3 per cent.

1.2. For the approval of any vehicle, the braking performance shall be measured during road tests conducted in the following conditions:

1.2.1. the vehicle's condition as regards mass must be as prescribed for each type of test and be specified in the test report;

1.2.2. the test must be carried out at the speeds prescribed for each type of test; if the maximum design speed of a vehicle is lower than the speed prescribed for a test, the test shall be performed at the vehicle's maximum speed;

- 1.2.3. during the tests, the force applied to the control of the braking system in order to obtain the prescribed performance must not exceed the maximum force laid down for the test vehicle's category;
- 1.2.4. the road must have a surface affording good adhesion, unless specified otherwise in the relevant annexes;
- 1.2.5. the tests must be performed when there is no wind liable to affect the results;
- 1.2.6. at the start of the tests, the tyres must be cold and at the pressure prescribed for the load actually borne by the wheels when the vehicle is stationary;
- 1.2.7. the prescribed performance must be obtained without locking of the wheels, without deviation of the vehicle from its course, and without abnormal vibration. 1/
- 1.2.8. For electric vehicles with motor(s) permanently connected to the wheels, all tests will be carried out with the motor(s) connected.
- 1.2.9. For electric vehicles as described in paragraph 1.2.8., fitted with an electric regenerative braking system of category A, behaviour tests defined in paragraph 1.4.3.1. of this annex shall be carried out on a track with a low adhesion coefficient (as defined in paragraph 5.2.2. of annex 13).
- 1.2.9.1. Moreover, for vehicles fitted with an electric regenerative braking system of category A, transient conditions as gear changes or accelerator control release shall not affect the behaviour of the vehicle in condition of tests described in paragraph 1.2.9.
- 1.2.10. During the tests specified in paragraphs 1.2.9. and 1.2.9.1., wheel locking is not allowed. However, steering correction is permitted if the angular rotation of the steering control is within 120° during the initial 2 seconds and not more than 240° in total.
- 1.3. Behaviour of the vehicle during braking
- 1.3.1. In braking tests, and in particular in those at high speed, the general behaviour of the vehicle during braking must be checked.
- 1.3.2. Behaviour of the vehicle during braking on a road on which adhesion is reduced. The behaviour of vehicles of categories M₁, M₂, M₃, N₁, N₂, N₃, O₃ and O₄ on a road on which adhesion is reduced must meet the requirements of annex 10 to this Regulation.
- 1.4. **Type-0 test (ordinary performance test with brakes cold)**
- 1.4.1. General
- 1.4.1.1. The brakes must be cold; a brake is deemed to be cold when the temperature measured on the disc or on the outside of the drum is below 100°C.
- 1.4.1.2. The test must be conducted in the following conditions:

1/ Wheel-locking is permitted where specifically mentioned.

1.4.1.2.1. the vehicle must be laden, the distribution of its mass among the axles being that stated by the manufacturer; where provision is made for several arrangements of the load on the axles the distribution of the maximum mass among the axles must be such that the load on each axle is proportional to the maximum permissible load for each axle. In the case of tractors for semi-trailers, the load may be re-positioned approximately half-way between the kingpin position resulting from the above loading conditions and the centreline of the rear axle(s);

1.4.1.2.2. every test must be repeated on the unladen vehicle. In the case of a power-driven vehicle there may be, in addition to the driver, a second person on the front seat who is responsible for noting the results of the test;

in the case of a tractor for a semi-trailer, the unladen tests will be conducted with the vehicle in its solo condition, including a mass representing the fifth wheel. It will also include a mass representing a spare wheel, if this is included in the standard specification of the vehicle;

in the case of a vehicle presented as a bare chassis-cab, a supplementary load may be added to simulate the mass of the body, not exceeding the minimum mass declared by the manufacturer in annex 2 to this Regulation;

1.4.1.2.3. the limits prescribed for minimum performance, both for tests with the vehicle unladen and for tests with the vehicle laden, shall be those laid down hereunder for each category of vehicles; the vehicle must satisfy both the prescribed stopping distance and the prescribed mean fully developed deceleration for the relevant vehicle category, but it may not be necessary to actually measure both parameters.

1.4.1.2.4. The road must be level.

1.4.2. **Type-0 test with engine disconnected**

The test must be carried out at the speed prescribed for the category to which the vehicle belongs, the figures prescribed in this connection being subject to a certain margin of tolerance. The minimum performance prescribed for each category must be attained.

1.4.3. **Type-0 test with engine connected**

1.4.3.1. Tests must also be carried out at various speeds, the lowest being equal to 30 per cent of the maximum speed of the vehicle and the highest being equal to 80 per cent of that speed. In the case of vehicles equipped with a speed limiter, this limiter speed shall be taken as the maximum speed of the vehicle. The maximum practical performance figures shall be measured and the behaviour of the vehicle shall be recorded in the test report. Tractors for semi-trailers, artificially loaded to simulate the effects of a laden semi-trailer shall not be tested beyond 80 km/h.

1.4.3.2. Further tests shall be carried out with the engine connected, from the speed prescribed for the category to which the vehicle

belongs. The minimum performance prescribed for each category must be attained. Tractive units for semi-trailers, artificially loaded to simulate the effects of a laden semi-trailer shall not be tested beyond 80 km/h.

1.4.4. **Type-0 test for vehicles of category O, equipped with compressed-air brakes.**

1.4.4.1. The braking performance of the trailer can be calculated either from the braking rate of the towing vehicle plus the trailer and the measured thrust on the coupling or, in certain cases, from the braking rate of the towing vehicle plus the trailer with only the trailer being braked. The engine of the towing vehicle must be disconnected during the braking test.

In the case where only the trailer is braked, to take account of the extra mass being retarded, the performance will be taken to be the mean fully developed deceleration.

1.4.4.2. With the exception of cases according to paragraphs 1.4.4.3. and 1.4.4.4. of this annex, it is necessary for the determination of the braking rate of the trailer to measure the braking rate of the towing vehicle plus the trailer and the thrust on the coupling. The towing vehicle has to meet the requirements laid down in annex 10 to this Regulation with regard to the relationship between the ratio T_M/P_M and the pressure p_m . The braking rate of the trailer is calculated according to the following formula:

$$Z_R = Z_{R+M} + \frac{D}{P_R}$$

where:

Z_R = braking rate of the trailer,

Z_{R+M} = braking rate of the towing vehicle plus the trailer,

D = thrust on the coupling,
 (tractive force: +D),
 (compressive force: -D)

P_R = total normal static reaction between road surface and wheels of trailer (annex 10).

1.4.4.3. If a trailer has a continuous or semi-continuous braking system where the pressure in the brake actuators does not change during braking despite the dynamic axle load shifting and in the case of semi-trailers the trailer alone may be braked. The braking rate of the trailer is calculated according to the following formula:

$$Z_R = (Z_{R+M} - R) \cdot \frac{P_M + P_R}{P_R} + R$$

where:

R = rolling resistance value = 0.01

P_M = total normal static reaction between road surface and wheels of towing vehicles for trailers (annex 10)

1.4.4.4. Alternatively, the evaluation of the braking rate of the trailer may be done by braking the trailer alone. In this case the pressure used shall be the same as that measured in the brake actuators during the braking of the combination.

1.5. **Type-I test (fade test)**

1.5.1. With repeated braking

1.5.1.1. The service braking systems of all power-driven vehicles must be tested by successively applying and releasing the brakes a number of times, the vehicle being laden, in the conditions shown in the table below:

Category of vehicles	Conditions			
	v_1 [km/h]	v_2 [km/h]	Δt [sec]	n
M_1	$80 \% v_{max}$ < 120	$1/2 v_1$	45	15
M_2	$80 \% v_{max}$ < 100	$1/2 v_1$	55	15
N_1	$80 \% v_{max}$ < 120	$1/2 v_1$	55	15
M_3, N_2, N_3	$80 \% v_{max}$ ≤ 60	$1/2 v_1$	60	20

where:

v_1 = initial speed, at beginning of braking

v_2 = speed at end of braking

v_{max} = maximum speed of vehicle

n = number of brake applications

Δt = duration of a braking cycle: time elapsing between the initiation of one brake application and the initiation of the next.

1.5.1.2. If the characteristics of the vehicle make it impossible to abide by the duration prescribed for Δt , the duration may be increased; in any event, in addition to the time necessary for braking and accelerating the vehicle, a period of 10 seconds must be allowed in each cycle for stabilizing the speed v_1 .

1.5.1.3. In these tests, the force applied to the control must be so adjusted as to attain the mean fully developed deceleration of 3 m/s^2 at the first brake application; this force must remain constant throughout the succeeding brake applications.

1.5.1.4. During brake applications, the highest gear ratio (excluding overdrive, etc.) must be continuously engaged.

- 1.5.1.5. For regaining speed after braking, the gearbox must be used in such a way as to attain the speed v_1 in the shortest possible time (maximum acceleration allowed by the engine and gearbox).
- 1.5.1.6. For electric vehicles not having sufficient autonomy to carry out the cycles of heating of the brakes, the tests shall be carried out from the specified speed during the first braking application and after that by using the maximum acceleration capability of the vehicle, and braking successively from the speed reached at the end of each cycle with a duration specified for the relevant category of vehicle.
- 1.5.2. With continuous braking
- 1.5.2.1. The service brakes of trailers of categories O_2 and O_3 must be tested in such a manner that, the vehicle being laden, the energy input to the brakes is equivalent to that recorded in the same period of time with a laden vehicle driven at a steady speed of 40 km/h on a 7 per cent down-gradient for a distance of 1.7 km.
- 1.5.2.2. The test may be carried out on a level road, the trailer being drawn by a towing vehicle; during the test, the force applied to the control must be adjusted so as to keep the resistance of the trailer constant (7 per cent of the maximum total stationary axle load of the trailer). If the power available for hauling is insufficient, the test can be conducted at a lower speed but over a greater distance as shown in the table below:

Speed [km/h]	Distance [metres]
40	1,700
30	1,950
20	2,500
15	3,100

- 1.5.3. Hot performance
- 1.5.3.1. At the end of the Type-I test (test described in paragraph 1.5.1. or test described in paragraph 1.5.2. of this annex) the hot performance of the service braking system must be measured in the same conditions (and in particular at a constant control force no greater than the mean force actually used) as for the Type-0 test with the engine disconnected (the temperature conditions may be different).
- 1.5.3.1.1. For power-driven vehicles this hot performance must not be less than 80 per cent of that prescribed for the category in question, nor less than 60 per cent of the figure recorded in the Type-0 test with the engine disconnected.
- 1.5.3.1.2. For electric vehicles fitted with an electric regenerative braking system of category A, during brake applications, the highest gear shall be continuously engaged and the separate electric regenerative braking control, if any, shall not be used.

1.5.3.1.3. However, in the case of trailers, the hot brake force at the periphery of the wheels when tested at 40 km/h must not be less than 36 per cent of the maximum stationary wheel load, nor less than 60 per cent of the figure recorded in the Type-0 test at the same speed.

1.5.3.2. In the case of a power-driven vehicle which satisfies the 60 per cent requirement specified in paragraph 1.5.3.1.1. above, but which cannot comply with the 80 per cent requirement of paragraph 1.5.3.1.1. above, a further hot performance test may be carried out using a control force not exceeding that specified in paragraph 2 of this annex for the relevant vehicle category. The results of both tests shall be entered in the report.

1.5.3.3. In the case of electric vehicles having carried out the brake heating cycles according to paragraph 1.5.1.6. of the present annex, the performance tests shall be carried out at the maximum possible speed which could be reached by the vehicle at the end of the brake heating cycles. For comparison, the Type-0 test with the cold brakes shall be repeated from this same speed, after reconditioning of the linings.

1.6. **Type-II test (downhill behaviour test)**

1.6.1. Laden power-driven vehicles must be tested in such a manner that the energy input is equivalent to that recorded in the same period of time with a laden vehicle driven at an average speed of 30 km/h on a 6 per cent down-gradient for a distance of 6 km, with the appropriate gear engaged and the endurance braking system, if the vehicle is equipped with one, being used. The gear engaged must be such that the speed of the engine (min^{-1}) does not exceed the maximum value prescribed by the manufacturer.

1.6.2. For vehicles in which the energy is absorbed by the braking action of the engine alone, a tolerance of ± 5 km/h on the average speed shall be permitted, and the gear enabling the speed to be stabilized at the value closest to 30 km/h on the 6 per cent down-gradient shall be engaged. If the performance of the braking action of the engine alone is determined by a measurement of deceleration, it shall be sufficient if the mean deceleration measured is at least 0.5 m/s^2 .

1.6.3. At the end of the test, the hot performance of the service braking system must be measured in the same conditions as for the Type-0 test with the engine disconnected (the temperature conditions may be different). This hot performance must give a stopping distance not exceeding the following values and a mean fully developed deceleration not less than the following values, using a control force not exceeding 70 daN,

category M_3 $0.15v + (1.33 v^2/130)$ (the second term corresponds to a mean fully developed deceleration $d_m = 3.75 \text{ m/s}^2$),

category N_3 $0.15v + (1.33 v^2/115)$ (the second term corresponds to a mean fully developed deceleration $d_m = 3.3 \text{ m/s}^2$).

1.6.4. Vehicles cited in paragraphs 1.8.1.1., 1.8.1.2. and 1.8.1.3. below must satisfy the Type-IIA test described in paragraph 1.8. below instead of the Type-II test.

1.7. Type-III test (fade test for vehicles of category O₄)

1.7.1. Track Test

For the road test the conditions shall be as follows:

Number of brake applications	20
Duration of a braking cycle	60 s
Initial speed at the beginning of braking	60 km/h
Braking applications	In these tests, the force applied to the control must be so adjusted as to attain the mean fully developed deceleration of 3 m/s ² in respect to the trailer mass P _R at the first brake application; this force must remain constant throughout the succeeding brake applications.

The braking rate of a trailer is calculated according to the formula given in paragraph 1.4.4.3. of this annex:

$$z_R = (z_{R+M} - R) \cdot \frac{(P_M + P_R)}{P_R} + R$$

The speed at the end of braking (annex 11, appendix 2, paragraph 3.1.5.):

$$v_2 = v_1 \cdot \sqrt{\frac{P_M + P_1 + P_2/4}{P_M + P_1 + P_2}}$$

where:

- z_R - braking rate of the trailer
- z_{R+M} - braking rate of the vehicle combination (motor vehicle and trailer)
- R - rolling resistance value = 0,01
- P_M - total normal static reaction between the road surface and the wheels of towing vehicle for trailer (kg)
- P_R - total normal static reaction between the road surface and the wheels of trailer (kg)
- P₁ - part of the mass of the trailer borne by the unbraked axle(s) (kg)
- P₂ - part of the mass of the trailer borne by the braked axle(s) (kg)
- v₁ - initial speed (km/h)
- v₂ - final speed (km/h)

1.7.2. Hot performance

At the end of the test according to paragraph 1.7.1., the hot performance of the service braking system must be measured under the same conditions as for the Type-0 test with, however, different temperature conditions and starting from an initial speed of 60 km/h. The hot brake-force at the periphery of the wheels must then not be less than 40 per cent of the maximum stationary wheel load, and not less than 60 per cent of the figure recorded in the Type-0 test at the same speed.

- 1.8. Type-IIA test (endurance braking performance)
- 1.8.1. Vehicles of the following categories shall be subject to the Type-IIA test:
- 1.8.1.1. Interurban motor coaches and long distance touring motor coaches of category M₃.
- 1.8.1.2. Vehicles of category N₃ which are authorized to tow a trailer of category O₄. If the maximum mass exceeds 26 tonnes, the test mass is limited to 26 tonnes or, in the case where the unladen mass exceeds 26 tonnes, this mass is to be taken into account by calculation.
- 1.8.1.3. Vehicles subject to marginal 10221 of Annex B of ADR (see annex 5).
- 1.8.2. Test conditions and performance requirements
- 1.8.2.1. The performance of the endurance braking system shall be tested at the maximum mass of the vehicle or of the vehicle combination.
- 1.8.2.2. Laden vehicles must be tested in such a manner that the energy input is equivalent to that recorded in the same period of time with a laden vehicle driven at an average speed of 30 km/h on a 7 per cent down-gradient for a distance of 6 km. During the test, the service, secondary and parking braking systems must not be engaged. The gear engaged must be such that the speed of the engine does not exceed the maximum value prescribed by the manufacturer. An integrated endurance braking system may be used, provided that it is suitably phased such that the service braking system is not applied; this may be verified by checking that its brakes remain cold, as defined in paragraph 1.4.1.1. of this annex.
- 1.8.2.3. For vehicles in which the energy is absorbed by the braking action of the engine alone, a tolerance of ± 5 km/h on the average speed shall be permitted, and the gear enabling the speed to be stabilized at a value closest to 30 km/h on a 7 per cent down-gradient shall be engaged. If the performance of the braking action of the engine alone is determined by measuring the deceleration, it shall be sufficient if the mean deceleration measured is at least 0.6 m/s^2 .
2. PERFORMANCE OF BRAKING SYSTEMS OF VEHICLES OF CATEGORIES M AND N
- 2.1. **Service braking system**
- 2.1.1. The service brakes of vehicles of categories M and N shall be tested under the conditions shown in the following table:

Category	M ₁	M ₂	M ₃	N ₁	N ₂	N ₃
Type of test	0-I	0-I	0-I-II or IIA	0-I	0-I	0-I-II
v	80 km/h	60 km/h	60 km/h	80 km/h	60 km/h	60 km/h
s ≤	$0.1v + \frac{v^2}{150}$	$0.15v + \frac{v^2}{130}$				
d _m ≥	5.8 m/s ²	5.0 m/s ²				
v = 0.80 v _{max} but not exceeding	160 km/h	100 km/h	90 km/h	120 km/h	100 km/h	90 km/h
s ≤	$0.1v + \frac{v^2}{130}$	$0.15v + \frac{v^2}{103} \cdot 5$				
d _m ≥	5.0 m/s ²	4.0 m/s ²				
F ≤	50 daN	70 daN				

where:

v = prescribed test speed, in km/h
s = stopping distance, in metres,
d_m = mean fully developed deceleration, in m/s²
F = force applied to foot control, in daN
v_{max} = maximum speed of the vehicle, in km/h

2.1.2. In the case of a power-driven vehicle authorized to tow an unbraked trailer, the minimum performance prescribed for the corresponding power-driven vehicle category (for the Type-0 test with engine disconnected) must be attained with the unbraked trailer coupled to the power-driven vehicle and with the unbraked trailer laden to the maximum mass declared by the power-driven vehicle manufacturer. However, in the case of category M₁ vehicles, the minimum combination performance shall be not less than 5.4 m/s² both in laden and unladen conditions.

The combination performance shall be verified by calculations referring to the maximum braking performance actually achieved by the power-driven vehicle alone (laden) during the Type-0 test with the engine disconnected, using the following formula (no practical tests with a coupled unbraked trailer are required):

$$d_{M+R} = d_M \cdot \frac{PM}{PM + PR}$$

where:

d_{M+R} = calculated mean fully developed deceleration of the

power-driven vehicle when coupled to an unbraked trailer,
 in m/s^2 ,

d_m = maximum mean fully developed deceleration of the power-driven vehicle alone achieved during the Type-0 test with engine disconnected, in m/s^2 ,

PM = mass of the power-driven vehicle (laden),

PR = maximum mass of an unbraked trailer which may be coupled, as declared by the power-driven vehicle manufacturer.

2.2. Secondary braking system

2.2.1. The secondary braking system, even if the control which actuates it is also used for other braking functions, must give a stopping distance not exceeding the following values and a mean fully developed deceleration not less than the following values:

Category M_1	$0.1 v + (2v^2/150)$ (the second term corresponds to a mean fully developed deceleration $d_m = 2.9 m/s^2$)
Category M_2, M_3	$0.15 v + (2v^2/130)$ (the second term corresponds to a mean fully developed deceleration $d_m = 2.5 m/s^2$)
Category N	$0.15 v + (2v^2/115)$ (the second term corresponds to a mean fully developed deceleration $d_m = 2.2 m/s^2$)

2.2.2. If the control is manual, the prescribed performance must be obtained by applying to the control a force not exceeding 40 daN in the case of vehicles of category M_1 , and 60 daN in the case of other vehicles, and the control must be so placed that it can be easily and quickly grasped by the driver.

2.2.3. If it is a foot control, the prescribed performance must be obtained by applying to the control a force not exceeding 50 daN in the case of vehicles of category M_1 , and 70 daN in the case of other vehicles, and the control must be so placed that it can be easily and quickly actuated by the driver.

2.2.4. The performance of the secondary braking system must be checked by the Type-0 test with engine disconnected from the following initial speeds:

M_1 : 80 km/h	M_2 : 60 km/h	M_3 : 60 km/h
N_1 : 70 km/h	N_2 : 50 km/h	N_3 : 40 km/h

2.2.5. The secondary braking effectiveness test shall be conducted by simulating the actual failure conditions in the service braking system.

2.2.6. For electric vehicles, the performances for the two following additional failures shall be checked:

2.2.6.1. For a total failure of the electric component of the service braking;

- 2.2.6.2. In the case where the electric component delivers the maximum braking force when a failure of the electric transmission occurs.
- 2.3. **Parking braking system**
- 2.3.1. The parking braking system must, even if it is combined with one of the other braking systems, be capable of holding the laden vehicle stationary on an 18 per cent up or down-gradient.
- 2.3.2. On vehicles to which the coupling of a trailer is authorized, the parking braking system of the towing vehicle must be capable of holding the combination of vehicles stationary on a 12 per cent up or down-gradient.
- 2.3.3. If the control is manual, the force applied to it must not exceed 40 daN in the case of vehicles of category M_1 , and 60 daN in the case of all other vehicles.
- 2.3.4. If it is a foot control, the force exerted on the control must not exceed 50 daN in the case of vehicles of category M_1 , and 70 daN in the case of all other vehicles.
- 2.3.5. A parking braking system which has to be actuated several times before it attains the prescribed performance is admissible.
- 2.3.6. To check compliance with the requirement specified in paragraph 5.2.1.2.4. of this Regulation, a Type-0 test must be carried out with the engine disconnected at an initial test speed of 30 km/h. The mean fully developed deceleration on application of the control of the parking brake system and the deceleration immediately before the vehicle stops shall not be less than 1.5 m/s^2 . The test shall be carried out with the laden vehicle.

The force exerted on the braking control device shall not exceed the specified values.

2.4. Residual braking after transmission failure

2.4.1. The residual performance of the service braking system, in the event of failure in a part of its transmission, must give a stopping distance not exceeding the following values and a mean fully developed deceleration not less than the following values, using a control force not exceeding 70 daN, when checked by the Type-0 test with the engine disconnected from the following initial speeds for the relevant vehicle category:

Stopping distance (m) and mean fully developed deceleration (d_m) [m/s^2]

Veh. Cat	v [km/h]	Stopping dist. LADEN [m]	d_m [m/s^2]	Stopping dist. UNLADEN [m]	d_m [m/s^2]
M ₁	80	$0.10v + (100/30).(v^2/150)$	1.7	$0.10v + (100/25).(v^2/150)$	1.5
M ₂	60	$0.15v + (100/30).(v^2/130)$	1.5	$0.15v + (100/25).(v^2/130)$	1.3
M ₃	60	$0.15v + (100/30).(v^2/130)$	1.5	$0.15v + (100/30).(v^2/130)$	1.5
N ₁	70	$0.15v + (100/30).(v^2/115)$	1.3	$0.15v + (100/25).(v^2/115)$	1.1
N ₂	50	$0.15v + (100/30).(v^2/115)$	1.3	$0.15v + (100/25).(v^2/115)$	1.1
N ₃	40	$0.15v + (100/30).(v^2/115)$	1.3	$0.15v + (100/30).(v^2/115)$	1.3

2.4.2. The residual braking effectiveness test shall be conducted by simulating the actual failure conditions in the service braking system.

3. PERFORMANCE OF BRAKING SYSTEMS OF VEHICLES OF CATEGORY O

3.1. Service braking system

3.1.1. Provision relating to tests of vehicles of category O₁:

Where the provision of a service braking system is mandatory, the performance of the system must meet the requirements laid down for vehicles of categories O₂ and O₃.

3.1.2. Provisions relating to tests of vehicles of categories O₂ and O₃:

3.1.2.1. If the service braking system is of the continuous or semi-continuous type, the sum of the forces exerted on the periphery of the braked wheels shall be at least x per cent of the maximum stationary wheel load, x having the following values:

	x [%]
full trailer, laden and unladen	: 50
semi-trailer, laden and unladen	: 45
centre-axle trailer, laden and unladen	: 50

3.1.2.2. If the trailer is fitted with a compressed-air braking system, the pressure in the supply line shall not exceed 7 bar during the brake

test and the signal value in the control line shall not exceed the following values, depending on the installation:

- (a) 6.5 bar in the pneumatic control line;
- (b) a digital demand value corresponding to 6.5 bar (as defined in ISO/DIS 11992:[1996]) in the electric control line.

The test speed is 60 km/h. A supplementary test at 40 km/h shall be carried out with the laden trailer for comparison with the Type-I test result.

3.1.2.3. If the braking system is of the inertia type, it must comply with the requirements of annex 12 to this Regulation.

3.1.2.4. In addition, the vehicles must undergo the Type-I test.

3.1.2.5. In the Type-I test of a semi-trailer, the mass braked by the latter's axle(s) must correspond to the maximum axle load(s) (not including the king pin load).

3.1.3. Provisions relating to tests of vehicles of category O₄:

3.1.3.1. If the service braking system is of the continuous or semi-continuous type, the sum of the forces exerted on the periphery of the braked wheels shall be at least x per cent of the maximum stationary wheel load, x having the following values:

	<u>x [%]</u>
full trailer, laden and unladen	50
semi-trailer, laden and unladen	45
centre-axle trailer, laden and unladen	50

3.1.3.2. If the trailer is fitted with a compressed air braking system, the pressure in the control line must not exceed 6.5 bar and the pressure in the supply line must not exceed 7.0 bar during the brake test. The test speed is 60 km/h.

3.1.3.3. In addition, the vehicles must undergo the Type-III test.

3.1.3.4. In the Type-III test of a semi-trailer, the mass braked by the latter's axle(s) must correspond to the maximum axle load(s).

3.2. **Parking braking system**

3.2.1. The parking braking system with which the trailer is equipped must be capable of holding the laden trailer stationary, when separated from the towing vehicle, on an 18 per cent up or down-gradient. The force applied to the control device must not exceed 60 daN.

3.3. **Automatic braking system**

3.3.1. The automatic braking performance in the event of a failure, as described in paragraph 5.2.1.18.3. of this Regulation, when testing the laden vehicle from a speed of 40 km/h, shall not be less than 13.5 per cent of the maximum stationary wheel load. Wheel-locking at performance levels above 13.5 per cent is permitted.

4. RESPONSE TIME

- 4.1. Where a vehicle is equipped with a service braking system which is totally or partially dependent on a source of energy other than the muscular effort of the driver, the following requirements must be satisfied:
- 4.1.1. In an emergency manoeuvre, the time elapsing between the moment when the control device begins to be actuated and the moment when the braking force on the least favourably placed axle reaches the level corresponding to the prescribed performance must not exceed 0.6 seconds.
- 4.1.2. In the case of vehicles fitted with compressed-air braking systems, the requirements of paragraph 4.1.1. above are considered to be satisfied if the vehicle complies with the provisions of annex 6 to this Regulation.
- 4.1.3. In the case of vehicles fitted with hydraulic braking systems, the requirements of paragraph 4.1.1. above are considered to be satisfied if, in an emergency manoeuvre, the deceleration of the vehicle or the pressure at the least favourable brake cylinder, reaches a level corresponding to the prescribed performance within 0.6 seconds.
-

Annex 5

ADDITIONAL PROVISIONS APPLICABLE TO VEHICLES SUBJECT
TO MARGINAL 10221 OF ANNEX B OF ADR */

1. SCOPE

This annex applies to the vehicles subject to marginal 10221 of annex B of the European Agreement concerning the International Carriage of Dangerous Goods by Road (ADR).

2. REQUIREMENTS

2.1. Anti-lock braking system

2.1.1. Power-driven vehicles which are authorized to tow a trailer of category O₄ shall be equipped with category 1 anti-lock systems complying with annex 13 of this Regulation.

2.1.2. Trailers of category O₄ shall be equipped with category A anti-lock systems complying with annex 13 of this Regulation.

2.2. Endurance braking system

Power-driven vehicles having a maximum mass exceeding 16 tonnes or authorized to tow a trailer of category O₄ shall be fitted with an endurance braking system which complies with the requirements of paragraph 1.8. of annex 4 of this Regulation. The following requirements also apply:

2.2.1. The endurance braking control configurations shall be chosen from those described in paragraph 2.14. of this Regulation.

2.2.2. In the case of an electrical failure of the anti-lock system, integrated or combined endurance braking systems shall be switched off automatically.

2.2.3. The effectiveness of the endurance braking system shall be controlled by the anti-lock braking system such that the axle(s) braked by the endurance braking system cannot be locked by that system at speeds above 15 km/h. However, this requirement shall not apply to that part of the braking system constituted by the natural engine braking.

2.2.4. The endurance braking system shall comprise several stages of effectiveness, including a low stage appropriate for the unladen condition. Where the endurance braking system of a power-driven vehicle is constituted by its engine, the different gear ratios shall be considered to provide the different stages of effectiveness.

2.2.5. In the case of towing vehicles, the loading condition, as described in paragraph 1.8.2.1. of annex 4 of this Regulation, shall be the maximum mass of the vehicle combination, comprising the maximum mass of the towing vehicle and its authorized maximum towed mass, but not exceeding a total of 44 tonnes.

*/ European Agreement concerning the International Carriage of Dangerous Goods by Road, as amended.

E/ECE/324
E/ECE/TRANS/505 } Rev.1/Add.12/Rev.4
Regulation No. 13
page 70
Annex 5

Annex 6

METHOD OF MEASURING THE RESPONSE TIME ON VEHICLES
EQUIPPED WITH COMPRESSED-AIR BRAKING SYSTEMS

1. GENERAL
 - 1.1. The response times of the service braking system shall be determined on the stationary vehicle, the pressure being measured at the intake to the cylinder of the least favourably placed brake. In the case of vehicles fitted with combined compressed-air/hydraulic braking systems, the pressure may be measured at the opening of the least favourably placed pneumatic unit. For vehicles equipped with load sensing valves, these devices must be set in the "laden" position.
 - 1.2. During the test, the stroke of the brake cylinders of the various axles shall be that required for brakes adjusted as closely as possible.
 - 1.3. The response times determined in accordance with the provisions of this annex shall be rounded to the nearest tenth of a second. If the figure representing the hundredth is five or more, the response time shall be rounded up to the next higher tenth.
2. POWER-DRIVEN VEHICLES
 - 2.1. At the beginning of each test, the pressure in the energy storage device shall be equal to the pressure at which the governor restores the feed to the system. In systems not equipped with a governor (e.g., pressure-limited compressors) the pressure in the energy storage device at the beginning of each test shall be 90 per cent of the pressure specified by the manufacturer and defined in paragraph 1.2.2.1. of Part A of annex 7 to this Regulation, used for the tests prescribed in this annex.
 - 2.2. The response times as a function of the actuating time (t_f) shall be obtained by a succession of full actuations, beginning with the shortest possible actuating time and increasing to a time of about 0.4 seconds. The measured values shall be plotted on a graph.
 - 2.3. The response time to be taken into consideration for the purpose of the test is that corresponding to an actuating time of 0.2 seconds. This response time can be obtained from the graph by interpolation.
 - 2.4. For an actuating time of 0.2 seconds, the time elapsing from the initiation of the braking system control actuation to the moment when the pressure in the brake cylinder reaches 75 per cent of its asymptotic value shall not exceed 0.6 seconds.
 - 2.5. In the case of power-driven vehicles having a pneumatic control line for trailers, in addition to the requirements of paragraph 1.1. of this annex, the response time must be measured at the extremity of a pipe 2.5 m long with an internal diameter of 13 mm which shall be joined to the coupling head of the control line of the service braking system. During this test, a volume of $385 \pm 5 \text{ cm}^3$ (which is deemed to be equivalent to the volume of a pipe 2.5 m long with an internal diameter of 13 mm and under a pressure of 6.5 bar) shall be connected to the coupling head of the supply line. Tractors for semi-trailers must be equipped with flexible pipes for making the connection to semi-trailers. The coupling heads will, therefore, be

at the extremity of those flexible pipes. The length and internal diameter of the pipes shall be entered at item 14.6. of the form conforming to the model in annex 2 to this Regulation.

2.6. The time elapsing from the initiation of brake-pedal actuation to the moment when

- (a) the pressure measured at the coupling head of the pneumatic control line,
- (b) the digital demand value in the electric control line measured according to ISO/DIS 11992:[1996].

reaches x per cent of its asymptotic, respectively final, value shall not exceed the times shown in the table below:

x [%]	t [s]
10	0.2
75	0.4

2.7. In the case of power-driven vehicles authorized to tow trailers of category O₃ or O₄ fitted with compressed-air braking systems, in addition to the above-mentioned requirements, the prescriptions in paragraph 5.2.1.18.4.1 of this Regulation shall be verified by conducting the following test:

- (a) by measuring the pressure at the extremity of a pipe 2.5 m long with an internal diameter of 13 mm which shall be joined to the coupling head of the supply line;
- (b) by simulating a failure of the control line at the coupling head;
- (c) by actuating the service braking control device in 0.2 seconds, as described in paragraph 2.3. above.

3. TRAILERS

3.1. The trailer's response times shall be measured without the power-driven vehicle. To replace the power-driven vehicle, it is necessary to provide a simulator to which the coupling heads of the supply line, the pneumatic control line and/or the connector of the electric control line are connected.

3.2. The pressure in the supply line shall be 6.5 bar.

3.3. The simulator for pneumatic control lines shall have the following characteristics:

3.3.1. It must have a reservoir with a capacity of 30 litres which shall be charged to a pressure of 6.5 bar before each test and which must not be recharged during each test. At the outlet of the braking control device, the simulator must incorporate an orifice with a diameter of from 4.0 to 4.3 mm inclusive. The volume of the pipe measured from the orifice up to and including the coupling head shall be $385 \pm 5 \text{ cm}^3$ (which is deemed to be equivalent to the volume of a pipe 2.5 m long with an internal diameter of 13 mm and under a pressure of 6.5 bar). The control line pressures referred to in paragraph 3.3.3. of this

annex shall be measured immediately downstream of the orifice.

- 3.3.2. The braking system control must be so designed that its performance in use is not affected by the tester.
- 3.3.3. The simulator must be set, e.g. through the choice of orifice in accordance with paragraph 3.3.1. of this annex in such a way that, if a reservoir of $385 \pm 5 \text{ cm}^3$ is joined to it, the time taken for the pressure to increase from 0.65 to 4.9 bar (10 and 75 per cent respectively of the nominal pressure of 6.5 bar) shall be 0.2 ± 0.01 seconds. If a reservoir of $1155 \pm 15 \text{ cm}^3$ is substituted for the above-mentioned reservoir, the time taken for the pressure to increase from 0.65 to 4.9 bar without further adjustment shall be 0.38 ± 0.02 seconds. Between these two pressure values, the pressure must increase in an approximately linear way. These reservoirs shall be connected to the coupling head without using flexible pipes and the connection shall have an internal diameter of not less than 10 mm.
- 3.3.4. The diagrams in the appendix to this annex give an example of the correct configuration of the simulator for setting and use.
- 3.4. The time elapsing between the moment when the pressure produced in the control line by the simulator reaches 0.65 bar and the moment when the pressure in the brake actuator of the trailer reaches 75 per cent of its asymptotic value must not exceed 0.4 seconds.
- 3.5. The simulator for electric control lines shall have the following characteristics: 1/

1/ Until uniform test procedures have been agreed, trailers with an electric control line shall be deemed to meet the requirements of paragraph 3. of this annex when the accompanying pneumatic control line fulfils the prescribed requirements.

Annex 6 - Appendix

EXAMPLE OF A SIMULATOR
 (see annex 6, paragraph 3)

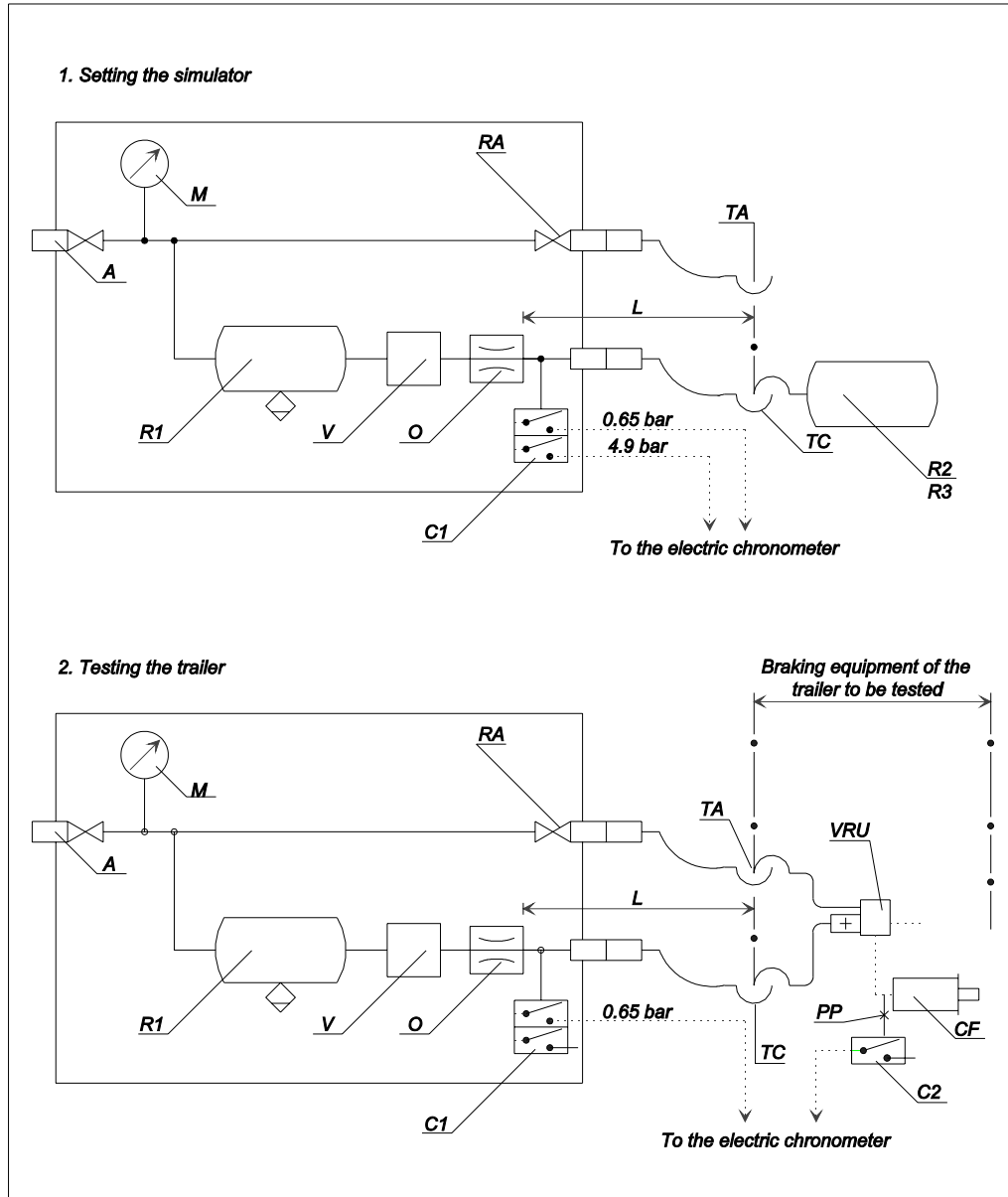

A	=	supply connection with shut-off valve
C1	=	pressure switch in the simulator, set at 0.65 bar and at 4.9 bar
C2	=	pressure switch to be connected to the brake actuator of the trailer, to operate at 75 per cent of the asymptotic pressure in the brake actuator CF
CF	=	brake cylinder
L	=	line from orifice O up to and including its coupling head TC, having an inner volume of $385 \pm 5 \text{ cm}^3$ under a pressure of 6.5 bar
M	=	pressure gauge
O	=	orifice with a diameter of not less than 4 mm and not more than 4.3 mm
PP	=	pressure test connection
R1	=	30-litre air reservoir with drain valve
R2	=	calibrating reservoir, including its coupling head TC, to be $385 \pm 5 \text{ cm}^3$
R3	=	calibrating reservoir, including its coupling head TC, to be $1155 \pm 15 \text{ cm}^3$
RA	=	shut-off valve
TA	=	coupling head, supply line
TC	=	coupling head, control line
V	=	braking system control device
VRU	=	emergency relay valve

Annex 7

PROVISIONS RELATING TO ENERGY SOURCES AND ENERGY STORAGE DEVICES
(ENERGY ACCUMULATORS)

A. COMPRESSED-AIR BRAKING SYSTEMS

1. CAPACITY OF ENERGY STORAGE DEVICES (ENERGY ACCUMULATORS)
 - 1.1. General
 - 1.1.1. Vehicles on which the operation of the braking system requires the use of compressed-air shall be equipped with energy storage devices (energy accumulators) of a capacity meeting the requirements of paragraphs 1.2. and 1.3. of this annex (Part A).
 - 1.1.2. It must be possible to easily identify the reservoirs of the different circuits.
 - 1.1.3. However, the energy storage devices shall not be required to be of a prescribed capacity if the braking system is such that in the absence of any energy reserve it is possible to achieve a braking performance at least equal to that prescribed for the secondary braking system.
 - 1.1.4. In verifying compliance with the requirements of paragraphs 1.2. and 1.3. of this annex, the brakes shall be adjusted as closely as possible.
 - 1.2. Power-driven vehicles
 - 1.2.1. The energy storage devices (energy accumulators) of power-driven vehicles shall be such that after eight full-stroke actuations of the service braking system control the pressure remaining in the energy storage device(s) shall be not less than the pressure required to obtain the specified secondary braking performance.
 - 1.2.2. Testing shall be performed in conformity with the following requirements:
 - 1.2.2.1. the initial energy level in the energy storage device(s) shall be that specified by the manufacturer. 1/ It shall be such as to enable the prescribed performance of the service braking system to be achieved;
 - 1.2.2.2. the energy storage device(s) shall not be fed; in addition, any energy storage device(s) for auxiliary equipment shall be isolated;
 - 1.2.2.3. In the case of power-driven vehicle to which the coupling of a trailer is authorized and with a pneumatic control line, the supply line shall be stopped and a compressed-air reservoir of 0.5 litre capacity shall be connected directly to the coupling head of the pneumatic control line. Before each braking operation, the pressure in this compressed-air reservoir shall be completely eliminated. After the test referred to in paragraph 1.2.1. above, the energy level supplied to the pneumatic control line shall not fall below a level equivalent to one-half the figure obtained at the first brake application.

1/ The initial energy level shall be stated in the approval document.

1.3. Trailers

1.3.1. The energy storage devices (energy accumulators) with which trailers are equipped shall be such that, after eight full-stroke actuations of the towing vehicle's service braking system, the energy level supplied to the operating members using the energy does not fall below a level equivalent to one-half of the figure obtained at the first brake application and without actuating either the automatic or the parking braking system of the trailer.

1.3.2. Testing shall be performed in conformity with the following requirements:

1.3.2.1. the pressure in the energy storage devices at the beginning of each test shall be 8.5 bar;

1.3.2.2. the supply line shall be stopped; in addition, any energy storage device(s) for auxiliary equipment shall be isolated;

1.3.2.3. the energy storage devices shall not be replenished during the test;

1.3.2.4. at each brake application, the pressure in the pneumatic control line shall be 7.5 bar.

1.3.2.5. at each brake application, the digital demand value in the electric control line shall be corresponding to a pressure of 7.5 bar.

2. CAPACITY OF ENERGY SOURCES

2.1. General

The compressors shall meet the requirements set forth in the following paragraphs.

2.2. Definitions

2.2.1. " p_1 " is the pressure corresponding to 65 per cent of the pressure p_2 defined in paragraph 2.2.2. below.

2.2.2. " p_2 " is the value specified by the manufacturer and referred to in paragraph 1.2.2.1. above.

2.2.3. " t_1 " is the time required for the relative pressure to rise from 0 to p_1 , and " t_2 " is the time required for the relative pressure to rise from 0 to p_2 .

2.3. Conditions of measurement

2.3.1. In all cases, the speed of the compressor shall be that obtained when the engine is running at the speed corresponding to its maximum power or at the speed allowed by the governor.

2.3.2. During the tests to determine the time t_1 and the time t_2 , the energy storage device(s) for auxiliary equipment shall be isolated.

2.3.3. If it is intended to attach a trailer to a power-driven vehicle, the trailer shall be represented by an energy storage device whose maximum relative pressure p (expressed in bar) is that which can be supplied through the towing vehicle's supply circuit and whose volume V , expressed in litres, is given by the formula $p \cdot V = 20 R$ (R being the permissible maximum mass, in tonnes, on the axles of

the trailer).

2.4. Interpretation of results

2.4.1. The time t_1 recorded for the least-favoured energy storage device shall not exceed:

2.4.1.1. Three minutes in the case of vehicles to which the coupling of a trailer is not authorized; or

2.4.1.2. Six minutes in the case of vehicles to which the coupling of a trailer is authorized.

2.4.2. The time t_2 recorded for the least-favoured energy storage device shall not exceed:

2.4.2.1. Six minutes in the case of vehicles to which the coupling of a trailer is not authorized; or

2.4.2.2. Nine minutes in the case of vehicles to which the coupling of a trailer is authorized.

2.5. Additional test

2.5.1. If the power-driven vehicle is equipped with one or more energy storage devices for auxiliary equipment having a total capacity exceeding 20 per cent of the total capacity of the braking energy storage devices, an additional test shall be performed during which no irregularity shall occur in the operation of the valves controlling the filling of the energy storage device(s) for auxiliary equipment.

2.5.2. It shall be verified during the aforesaid test that the time t_3 necessary to raise the pressure from 0 to p_2 in the least-favoured braking energy storage device is less than:

2.5.2.1. Eight minutes in the case of vehicles to which the coupling of a trailer is not authorized; or

2.5.2.2. Eleven minutes in the case of vehicles to which the coupling of a trailer is authorized.

2.5.3. The test shall be performed in the conditions prescribed in paragraphs 2.3.1. and 2.3.3. above.

2.6. Towing vehicles

2.6.1. Power-driven vehicles to which the coupling of a trailer is authorized shall also comply with the above requirements for vehicles not so authorized. In that case, the tests in paragraphs 2.4.1. and 2.4.2. (and 2.5.2.) of this annex will be conducted without the energy storage device mentioned in paragraph 2.3.3. above.

B. VACUUM BRAKING SYSTEMS

1. CAPACITY OF ENERGY STORAGE DEVICES (ENERGY ACCUMULATORS)

1.1. General

1.1.1. Vehicles on which operation of the braking system requires the use of a vacuum shall be equipped with energy storage devices (energy

accumulators) of a capacity meeting the requirements of paragraphs 1.2. and 1.3. of this annex (Part B).

- 1.1.2. However, the energy storage devices shall not be required to be of a prescribed capacity if the braking system is such that in the absence of any energy reserve it is possible to achieve a braking performance at least equal to that prescribed for the secondary braking system.
- 1.1.3. In verifying compliance with the requirements of paragraphs 1.2. and 1.3. of this annex, the brakes shall be adjusted as closely as possible.
- 1.2. Power-driven vehicles
- 1.2.1. The energy storage devices (energy accumulators) of power-driven vehicles shall be such that it is still possible to achieve the performance prescribed for the secondary braking system:
- 1.2.1.1. after eight full-stroke actuations of the service braking system control where the energy source is a vacuum pump; and
- 1.2.1.2. after four full-stroke actuations of the service brake control where the energy source is the engine.
- 1.2.2. Testing shall be performed in conformity with the following requirements:
- 1.2.2.1. the initial energy level in the energy storage device(s) shall be that specified by the manufacturer. 1/ It shall be such as to enable the prescribed performance of the service braking system to be achieved and shall correspond to a vacuum not exceeding 90 per cent of the maximum vacuum furnished by the energy source;
- 1.2.2.2. the energy storage device(s) shall not be fed; in addition any energy storage device(s) for auxiliary equipment shall be isolated;
- 1.2.2.3. in the case of a power-driven vehicle authorized to tow a trailer, the supply line shall be stopped and an energy storage device of 0.5 litre capacity shall be connected to the control line. After the test referred to in paragraph 1.2.1. above, the vacuum level provided at the control line shall not have fallen below a level equivalent to one-half of the figure obtained at the first brake application.
- 1.3. Trailers (categories O₁ and O₂ only)
- 1.3.1. The energy storage devices (energy accumulators) with which trailers are equipped shall be such that the vacuum level provided at the user points shall not have fallen below a level equivalent to one-half of the value obtained at the first brake application after a test comprising four full-stroke actuations of the trailer's service braking system.
- 1.3.2. Testing shall be performed in conformity with the following requirements:

1/ The initial energy level shall be stated in the approval document.

- 1.3.2.1. the initial energy level in the energy storage device(s) shall be that specified by the manufacturer. 1/ It shall be such as to enable the prescribed performance of the service braking system to be achieved;
 - 1.3.2.2. the energy storage device(s) shall not be fed; in addition, any energy storage device(s) for auxiliary equipment shall be isolated.
2. CAPACITY OF ENERGY SOURCES
 - 2.1. General
 - 2.1.1. Starting from the ambient atmospheric pressure, the energy source shall be capable of achieving in the energy storage device(s), in 3 minutes, the initial level specified in paragraph 1.2.2.1. above. In the case of a power-driven vehicle to which the coupling of a trailer is authorized, the time taken to achieve that level in the conditions specified in paragraph 2.2. below shall not exceed 6 minutes.
 - 2.2. Conditions of measurement
 - 2.2.1. The speed of the vacuum source shall be:
 - 2.2.1.1. where the vacuum source is the vehicle engine, the engine speed obtained with the vehicle stationary, the neutral gear engaged and the engine idling;
 - 2.2.1.2. where the vacuum source is a pump, the speed obtained with the engine running at 65 per cent of the speed corresponding to its maximum power output; and
 - 2.2.1.3. where the vacuum source is a pump and the engine is equipped with a governor, the speed obtained with the engine running at 65 per cent of the maximum speed allowed by the governor.
 - 2.2.2. Where it is intended to couple to the power-driven vehicle a trailer whose service braking system is vacuum-operated, the trailer shall be represented by an energy storage device having a capacity V in litres determined by the formula $V = 15 R$, where R is the maximum permissible mass, in tonnes, on the axles of the trailer.

C. HYDRAULIC BRAKING SYSTEMS WITH STORED ENERGY

1. CAPACITY OF ENERGY STORAGE DEVICES (ENERGY ACCUMULATORS)
 - 1.1. General
 - 1.1.1. Vehicles on which operation of the braking system requires the use of stored energy provided by hydraulic fluid under pressure shall be equipped with energy storage devices (energy accumulators) of a capacity meeting the requirements of paragraph 1.2. of this annex (Part C).
 - 1.1.2. However, the energy storage devices shall not be required to be of a prescribed capacity if the braking system is such that in the absence of any energy reserve it is possible with the service

braking system control to achieve a braking performance at least equal to that prescribed for the secondary braking system.

- 1.1.3. In verifying compliance with the requirements of paragraphs 1.2.1., 1.2.2. and 2.1. of this annex, the brakes shall be adjusted as closely as possible and, for paragraph 1.2.1., the rate of full-stroke actuations must be such as to provide an interval of at least 60 seconds between each actuation.
- 1.2. Power-driven vehicles
 - 1.2.1. Power-driven vehicles equipped with a hydraulic braking system with stored energy shall meet the following requirements:
 - 1.2.1.1. After eight full-stroke actuations of the service braking system control, it shall still be possible to achieve, on the ninth application, the performance prescribed for the secondary braking system.
 - 1.2.1.2. Testing shall be performed in conformity with the following requirements:
 - 1.2.1.2.1. testing shall commence at a pressure that may be specified by the manufacturer but is not higher than the cut-in pressure;
 - 1.2.1.2.2. the energy storage device(s) shall not be fed; in addition, any energy storage device(s) for auxiliary equipment shall be isolated.
 - 1.2.2. Power-driven vehicles equipped with a hydraulic braking system with stored energy which cannot meet the requirements of paragraph 5.2.1.5.1. of this Regulation shall be deemed to satisfy that paragraph if the following requirements are met:
 - 1.2.2.1. After any single transmission failure it shall still be possible after eight full-stroke actuations of the service braking system control, to achieve, at the ninth application, at least the performance prescribed for the secondary braking system or, where secondary performance requiring the use of stored energy is achieved by a separate control, it shall still be possible after eight full-stroke actuations to achieve, at the ninth application, the residual performance prescribed in paragraph 5.2.1.4. of this Regulation.
 - 1.2.2.2. Testing shall be performed in conformity with the following requirements:
 - 1.2.2.2.1. with the energy source stationary or operating at a speed corresponding to the engine idling speed, any transmission failure may be induced. Before inducing such a failure, the energy storage device(s) shall be at a pressure that may be specified by the manufacturer but not exceeding the cut-in pressure;
 - 1.2.2.2.2. the auxiliary equipment and its energy storage devices, if any, shall be isolated.
 2. CAPACITY OF HYDRAULIC FLUID ENERGY SOURCES
 - 2.1. The energy sources shall meet the requirements set out in the following paragraphs:

2.1.1. Definitions

2.1.1.1. " p_1 " represents the maximum system operational pressure (cut-out pressure) in the energy storage device(s) specified by the manufacturer.

2.1.1.2. " p_2 " represents the pressure after four full-stroke actuations with the service braking system control, starting at p_1 , without having fed the energy storage device(s).

2.1.1.3. " t " represents the time required for the pressure to rise from p_2 to p_1 in the energy storage device(s) without application of the service braking system control.

2.1.2. Conditions of measurement

2.1.2.1. During the test to determine the time t , the feed rate of the energy source shall be that obtained when the engine is running at the speed corresponding to its maximum power or at the speed allowed by the over-speed governor.

2.1.2.2. During the test to determine the time t , energy storage device(s) for auxiliary equipment shall not be isolated other than automatically.

2.1.3. Interpretation of results

2.1.3.1. In the case of all vehicles except those of categories M_3 , N_2 and N_3 , the time t shall not exceed 20 seconds.

2.1.3.2. In the case of vehicles of categories M_3 , N_2 and N_3 , the time t shall not exceed 30 seconds.

3. CHARACTERISTICS OF WARNING DEVICES

With the engine stationary and commencing at a pressure that may be specified by the manufacturer but does not exceed the cut-in pressure, the warning device shall not operate following two full-stroke actuations of the service braking system control.

Annex 8

PROVISIONS RELATING TO SPECIFIC CONDITIONS FOR SPRING BRAKING SYSTEMS

1. DEFINITION
 - 1.1. "Spring braking systems" are braking systems in which the energy required for braking is supplied by one or more springs acting as an energy storage device (energy accumulator).
 - 1.1.1. The energy necessary to compress the spring in order to release the brake is supplied and controlled by the "control" actuated by the driver (see definition in paragraph 2.4. of this Regulation).
 - 1.2. "Spring compression chamber" means the chamber where the pressure variation that induces the compression of the spring is actually produced.
 - 1.3. If the compression of the springs is obtained by means of a vacuum device, "pressure" shall mean negative pressure everywhere in this annex.
2. GENERAL
 - 2.1. A spring braking system shall not be used as a service braking system. However, in the event of a failure in a part of the transmission of the service braking system, a spring braking system may be used to achieve the residual performance prescribed in paragraph 5.2.1.4. of this Regulation provided that the driver can graduate this action. In the case of power-driven vehicles, with the exception of tractors for semi-trailers meeting the requirements specified in paragraph 5.2.1.4.1 of this Regulation, the spring braking system shall not be the sole source of residual braking. Vacuum spring braking systems shall not be used for trailers.
 - 2.2. A small variation in any of the pressure limits which may occur in the spring compression chamber feed circuit shall not cause a significant variation in the braking force.
 - 2.3. The feed circuit to the spring compression chamber must either include an own energy reserve or must be fed from at least two independent energy reserves. The trailer supply line may be branched from this feed line under the condition that a pressure drop in the trailer supply line must not be able to apply the spring brake actuators. Auxiliary equipment may only draw its energy from the feed line for the spring brake actuators under the condition that its operation, even in the event of damage to the energy source, cannot cause the energy reserve for the spring brake actuators to fall below a level from which one release of the spring brake actuators is possible. In any case, during re-charging of the braking system from zero pressure, the spring brakes must not release until the pressure in the service braking system is sufficient to ensure at least the prescribed secondary braking performance of the laden vehicle, using the service braking system control. Similarly, once applied, the spring brakes must not release unless there is sufficient pressure in the service braking system to at least provide the prescribed residual braking performance of the laden vehicle by application of the service braking control. This paragraph does not apply to trailers.
 - 2.4. In power-driven vehicles, the system must be so designed that it is possible to apply and release the brakes at least three times if the

initial pressure in the spring compression chamber is equal to the maximum design pressure. In the case of trailers, it must be possible to release the brakes at least three times after the trailer has been uncoupled, the pressure in the supply line being 7.5 bar before the uncoupling. However, prior to the check the emergency brake shall be released. These conditions must be satisfied when the brakes are adjusted as closely as possible. In addition, it must be possible to apply and release the parking braking system as specified in paragraph 5.2.2.10. of this Regulation when the trailer is coupled to the towing vehicle.

- 2.5. For power-driven vehicles, the pressure in the spring compression chamber beyond which the springs begin to actuate the brakes, the latter being adjusted as closely as possible, shall not be greater than 80 per cent of the minimum level of the normal available pressure.

In the case of trailers, the pressure in the spring compression chamber beyond which the springs begin to actuate the brakes must not be greater than that obtained after four full-stroke actuations of the service braking system in accordance with paragraph 1.3 of Part A of annex 7 to this Regulation. The initial pressure is fixed at 7.0 bar.

- 2.6. When the pressure in the line feeding energy to the spring compression chamber - excluding lines of an auxiliary release device using a fluid under pressure - falls to the level at which the brake parts begin to move, an optical or audible warning device shall be actuated. Provided this requirement is met, the warning device may comprise the red warning signal specified in paragraph 5.2.1.29.1.1. of this Regulation. This provision does not apply to trailers.
- 2.7. If a power-driven vehicle authorized to tow a trailer with a continuous or semi-continuous braking system is fitted with a spring braking system, automatic application of the said system shall cause application of the trailer's brakes.

3. RELEASE SYSTEM

- 3.1. A spring braking system must be so designed that, in the event of a failure in that system, it is still possible to release the brakes. This may be achieved by the use of an auxiliary release device (pneumatic, mechanical, etc.).

Auxiliary release devices using an energy reserve for releasing must draw their energy from an energy reserve which is independent from the energy reserve normally used for the spring braking system. The pneumatic or hydraulic fluid in such an auxiliary release device may act on the same piston surface in the spring compression chamber which is used for the normal spring braking system under the condition that the auxiliary release device uses a separate line. The junction of this line with the normal line connecting the control device with the spring brake actuators shall be at each spring brake actuator immediately before the port to the spring compression chamber, if not integrated in the body of the actuator. This junction shall include a device which prevents an influence of one line on the other. The requirements of paragraph 5.2.1.6. of this Regulation also apply to this device.

- 3.1.1. For the purposes of the requirement of paragraph 3.1. above, components of the braking system transmission shall not be regarded as subject to failure if under the terms of paragraph 5.2.1.2.7. of this Regulation they are not regarded as liable to breakage, provided that they are made of metal or of a material having similar characteristics and do not undergo significant distortion in normal braking.
- 3.2. If the operation of the auxiliary device referred to in paragraph 3.1. above requires the use of a tool or spanner, the tool or spanner shall be kept on the vehicle.
-

Annex 9

PROVISIONS RELATING TO PARKING BRAKING SYSTEMS EQUIPPED WITH A
MECHANICAL BRAKE-CYLINDER LOCKING DEVICE (Lock actuators)

1. DEFINITION

"Mechanical brake-cylinder locking device" means a device which ensures braking operation of the parking braking system by mechanically locking the brake piston rod. Mechanical locking is effected by exhausting the compressed fluid held in the locking chamber; it is so designed that unlocking can be effected by restoring pressure in the locking chamber.

2. SPECIAL REQUIREMENTS

- 2.1. When the pressure in the locking chamber approaches the level at which mechanical locking occurs, an optical or audible warning device shall come into action. Provided this requirement is met, the warning device may comprise the red warning signal specified in paragraph 5.2.1.29.1.1. of this Regulation. This provision shall not apply to trailers.

In the case of trailers, the pressure corresponding to mechanical locking must not exceed 4 bar. It must be possible to achieve parking braking performance after any single failure of the trailer service braking system. In addition, it must be possible to release the brakes at least three times after the trailer has been uncoupled, the pressure in the supply line being 6.5 bar before the uncoupling. These conditions must be satisfied when the brakes are adjusted as closely as possible. It must also be possible to apply and release the parking braking system as specified in paragraph 5.2.2.10. of this Regulation when the trailer is coupled to the towing vehicle.

- 2.2. In cylinders equipped with a mechanical locking device, movement of the brake piston shall be ensured by energy from either of two independent energy storage devices.
- 2.3. It shall not be possible to release the locked brake cylinder unless it is certain that after such release the brake can be applied again.
- 2.4. In the event of a failure of the energy source feeding the locking chamber, an auxiliary release device (e.g. mechanical, or pneumatic which may use the air contained in one of the vehicle's tyres) shall be available.
- 2.5. The control must be such that, when actuated, it performs the following operations in sequence: it applies the brakes so as to provide the degree of efficiency required for parking braking, locks the brakes in that position and then cancels out the brake application force.

Annex 10

DISTRIBUTION OF BRAKING AMONG THE AXLES OF VEHICLES AND REQUIREMENTS
FOR COMPATIBILITY BETWEEN TOWING VEHICLES AND TRAILERS

1. GENERAL REQUIREMENTS

- 1.1. Vehicles of categories M, N, O₃ and O₄ which are not equipped with an anti-lock system as defined in annex 13 to this Regulation shall meet all the requirements of this annex. If a special device is used, this must operate automatically.

However, vehicles - other than those of category M_1 - which are equipped with an anti-lock system as defined in annex 13, shall also meet the requirements of paragraphs 7 and 8 of this annex if they are in addition fitted with a special automatic device which controls the distribution of braking among the axles. In the event of failure of its control, it shall be possible to stop the vehicle as stipulated under paragraph 6 of this annex.

- 1.2. The requirements relating to the diagrams specified in paragraphs 3.1.5., 3.1.6., 4.1., 5.1. and 5.2. of this annex, are valid both for power-driven vehicles with a pneumatic control line according to paragraph 5.1.3.1.1. of this Regulation and for power-driven vehicles with an electric control line according to paragraph 5.1.3.1.3. of this Regulation. In both cases, the reference value (abscissa of the diagrams) will be the value of the transmitted pressure in the control line: for vehicles equipped according to paragraph 5.1.3.1.1. of this Regulation, this will be the actual pneumatic pressure in the control line (p_m); for vehicles equipped according to paragraph 5.1.3.1.3. of this Regulation, this will be the pressure corresponding to the transmitted digital demand value in the electric control line, according to ISO/DIS 11992:[1996]. Vehicles equipped according to paragraph 5.1.3.1.2. of this Regulation (with both pneumatic and electric control lines) shall satisfy the requirements of the diagrams related to both control lines. However, identical braking characteristic curves related to both control lines are not required.

2. SYMBOLS

i	=	axle index ($i = 1$, front axle; $i = 2$, second axle; etc.)
P_i	=	normal reaction of road surface on axle i under static conditions
N_i	=	normal reaction of road surface on axle i under braking
T_i	=	force exerted by the brakes on axle i under normal braking conditions on the road
f_i	=	T_i/N_i , adhesion utilized by axle i <u>1/</u>
J	=	deceleration of vehicle
g	=	acceleration due to gravity: $g = 10 \text{ m/s}^2$
z	=	braking rate of vehicle = J/g <u>2/</u>
P	=	mass of vehicle
h	=	height above ground of centre of gravity specified by the manufacturer and agreed by the Technical Services conducting the approval test
E	=	wheelbase

1/ "Adhesion utilization curves" of a vehicle means curves showing, for specified load conditions, the adhesion utilized by each axle i plotted against the braking rate of the vehicle.

2/ For semi-trailers, z is the braking force divided by the static load on the semi-trailer axle(s).

k	=	theoretical coefficient of adhesion between tyre and road
K _C	=	correction factor: semi-trailer laden
K _V	=	correction factor: semi-trailer unladen
T _M	=	sum of braking forces at the periphery of all wheels of towing vehicles for trailers
P _M	=	total normal static reaction of road surface on wheels of towing vehicles for trailers <u>1/</u>
p _m	=	pressure at coupling head of control line
T _R	=	sum of braking forces at periphery of all wheels of trailer
P _R	=	total normal static reaction of road surface on all wheels of trailer <u>2/</u>
P _{R max}	=	value of P _R at maximum mass of trailer
E _R	=	distance between king-pin and centre of axle or axles of semi-trailer
h _R	=	height above ground of centre of gravity of semi-trailer specified by the manufacturer and agreed by the technical services conducting the approval test

3. REQUIREMENTS FOR POWER-DRIVEN VEHICLES

3.1. Two-axled vehicles

3.1.1. For all categories of vehicles for k values between 0.2 and 0.8: 5/

$$z \geq 0.10 + 0.85 (k - 0.20)$$

3.1.2. For all states of load of the vehicle, the adhesion utilization curve of the rear axle shall not be situated above that for the front axle:

3.1.2.1. for all braking rates between 0.15 and 0.80 in the case of vehicles of category M₁.

However, for vehicles of this category in the range of z values

1/ As referred to in paragraph 1.4.4.3. of annex 4 to this Regulation.

2/ As referred to in paragraph 1.4.4.2. of annex 4 to this Regulation.

5/ The provisions of paragraph 3.1.1. do not affect the requirements of annex 4 to this Regulation relating to the braking performance. However, if, in tests made under the provisions of paragraph 3.1.1., braking performances are obtained which are higher than those prescribed in annex 4, the provisions relating to the adhesion utilization curves shall be applied within the areas of diagrams 1A, 1B and 1C of this annex defined by the straight lines k = 0.8 and z = 0.8.

between 0.30 and 0.45, an inversion of the adhesion utilization curves is permitted provided that the adhesion utilization curve of the rear axle does not exceed by more than 0.05 the line defined by the formula $k = z$ (line of ideal adhesion utilization - see diagram 1A of this annex);

- 3.1.2.2. for all braking rates between 0.15 and 0.50 in the case of vehicles of category N_1 . 1/

This condition is also considered satisfied if, for braking rates between 0.15 and 0.30, the adhesion utilization curves for each axle are situated between two lines parallel to the line of ideal adhesion utilization given by the equation $k = z \pm 0.08$ as shown in diagram 1C of this annex where the adhesion utilization curve for the rear axle may cross the line $k = z - 0.08$; and complies for a braking rate between 0.30 and 0.50, with the relation $z \geq k - 0.08$; and between 0.50 and 0.61 with the relation $z \geq 0.5k + 0.21$.

- 3.1.2.3. for all braking rates between 0.15 and 0.30 in the case of vehicles of other categories.

This condition is also considered satisfied if, for braking rates between 0.15 and 0.30, the adhesion utilization curves for each axle are situated between two lines parallel to the line of ideal adhesion utilization given by the equation $k = z \pm 0.08$ as shown in diagram 1B of this annex and the adhesion utilization curve for the rear axle for braking rates $z \geq 0.3$ complies with the relation

$$z \geq 0.3 + 0.74 (k - 0.38).$$

- 3.1.3. In the case of a power-driven vehicle authorized to tow trailers of category O_3 or O_4 fitted with compressed-air braking systems.

- 3.1.3.1. When tested with the energy source stopped, the supply line blocked off, a reservoir of 0.5 litre capacity connected to the pneumatic control line, and the system at cut-in and cut-out pressures, the pressure at full application of the braking control shall be between 6.5 and 8.5 bar at the coupling heads of the supply line and the pneumatic control line, irrespective of the load condition of the vehicle.

- 3.1.3.2. For vehicles equipped with an electric control line; a full application of the control of the service braking system shall provide a digital demand value corresponding to a pressure between 6.5 and 8.5 bar (see ISO/DIS 11992:[1996]).

- 3.1.3.3. These values shall be demonstrably present in the power-driven vehicle when uncoupled from the trailer. The compatibility bands in the diagrams specified in paragraphs 3.1.5., 3.1.6., 4.1., 5.1. and 5.2. of this annex, should not be extended beyond 7.5 bar and/or the corresponding digital demand value (see ISO/DIS 11992:[1996]).

- 3.1.3.4. It must be ensured that at the coupling head of the supply line a pressure of at least 7 bar is available when the system is at cut-in pressure. This pressure shall be demonstrated without applying

1/ Vehicles of category N_1 with a laden/unladen rear axle loading ratio not exceeding 1.5 or having a maximum mass of less than 2 tonnes will have to comply with the requirements for category M_1 vehicles laid down in paragraph 3.1.2.1. of this annex as from 1 October 1990.

the service brakes.

3.1.4. Verification of the requirements of paragraphs 3.1.1. and 3.1.2.

3.1.4.1. In order to verify the requirements of paragraphs 3.1.1. and 3.1.2. of this annex, the manufacturer shall provide the adhesion utilization curves for the front and rear axles calculated by the formulae:

$$f_1 = \frac{T_1}{N_1} = \frac{T_1}{P_1 + z \cdot \frac{h}{E} \cdot P \cdot g}$$

$$f_2 = \frac{T_2}{N_2} = \frac{T_2}{P_2 - z \cdot \frac{h}{E} \cdot P \cdot g}$$

The curves shall be plotted for both the following load conditions:

- 3.1.4.1.1. unladen, in running order with the driver on board; in the case of a vehicle presented as a bare chassis-cab, a supplementary load may be added to simulate the mass of the body, not exceeding the minimum mass declared by the manufacturer in annex 2 to this Regulation,
- 3.1.4.1.2. laden; where provision is made for several possibilities of load distribution, the one whereby the front axle is the most heavily laden shall be the one considered.
- 3.1.4.2. If it is not possible, for vehicles with (permanent) all-wheel drive, to carry out the mathematical verification pursuant to paragraph 3.1.4.1., the manufacturer may instead verify by means of a wheel lock sequence test that, for all braking rates between 0.15 and 0.8, lockup of the front wheels occurs either simultaneously with or before the lockup of the rear wheels.
- 3.1.4.3. Procedure to verify the requirements of paragraph 3.1.4.2.
- 3.1.4.3.1. The wheel lock sequence test shall be conducted on road surfaces with a coefficient of adhesion of not more than 0.3 and of about 0.8 (dry road) from the initial test speeds specified in paragraph 3.1.4.3.2.
- 3.1.4.3.2. Test speeds:
- 60 km/h, but not exceeding $0.8 v_{\max}$ for decelerations on low coefficient of friction road surfaces;
- 80 km/h, but not exceeding v_{\max} for decelerations on high coefficient of friction road surfaces.
- 3.1.4.3.3. The pedal force applied may exceed the permissible actuation forces pursuant to annex 4, paragraph 2.1.1.
- 3.1.4.3.4. Pedal force is applied and increased such that the second wheel on

the vehicle will reach lockup between 0.5 and 1 s after initiating the brake application, until lockup of both wheels on one axle occurs (additional wheels may also lock during the test, e.g. in the case of simultaneous lockup).

- 3.1.4.4. The tests prescribed in paragraph 3.1.4.2. shall be carried out twice on each road surface. If the result of one test fails, a third, hence decisive test shall be carried out.
- 3.1.4.5. For electric vehicles fitted with an electric regenerative braking system of category B, where the electric regenerative braking capacity is influenced by the electric state of charge, the curves shall be plotted by taking account of the electric regenerative braking component under the minimum and maximum conditions of delivered braking force. This requirement is not applicable if the vehicle is equipped with an anti-lock device which controls the wheels connected to the electric regenerative braking and shall be replaced by the requirements of annex 13.
- 3.1.5. Towing vehicles other than tractors for semi-trailers
- 3.1.5.1. In the case of a power-driven vehicle authorized to tow trailers of category O₃ or O₄ fitted with a compressed air braking system, the permissible relationship between the braking rate T_M/P_M and the pressure p_m shall lie within the areas shown on diagram 2 of this annex for all pressures between 0.2 and 7.5 bar.
- 3.1.6. Tractors for semi-trailers
- 3.1.6.1. Tractors with unladen semi-trailer. An unladen combination is understood to be a tractor in running order, with the driver on board, coupled to an unladen semi-trailer. The dynamic load of the semi-trailer on the tractor shall be represented by a static mass P_s mounted at the fifth wheel coupling equal to 15 per cent of the maximum mass on the coupling. The braking forces must continue to be regulated between the state of the "tractor with unladen semi-trailer" and that of the "tractor alone"; the braking forces relating to the "tractor alone" shall be verified.
- 3.1.6.2. Tractors with laden semi-trailer. A laden combination is understood to be a tractor in running order, with the driver on board, coupled to a laden semi-trailer. The dynamic load of the semi-trailer on the tractor shall be represented by a static mass P_s mounted at the fifth wheel coupling equal to:

$$P_s = P_{so} (1 + 0.45z)$$

where:

P_{so} represents the difference between the maximum laden mass of the tractor and its unladen mass.

For h the following value shall be taken:

$$h = \frac{h_o \cdot P_o + h_s \cdot P_s}{P}$$

where:

h_o is the height of the centre of gravity of the tractor;

h_s is the height of the coupling on which the semi-trailer rests;

P_o is the unladen mass of the tractor alone

$$P = P_o + P_s = \frac{P_1 + P_2}{g}$$

3.1.6.

3. In the case of a vehicle fitted with a compressed air braking system, the permissible relationship between the braking rate T_M/P_M and the pressure p_m shall be within the areas shown on diagram 3 of this annex for all pressures between 0.2 and 7.5 bar.

3.2. Vehicles with more than two axles.

The requirements of paragraph 3.1. of this annex shall apply to vehicles with more than two axles. The requirements of paragraph 3.1.2. of this annex with respect to wheel lock sequence shall be considered to be met if, in the case of braking rates between 0.15 and 0.30, the adhesion utilized by at least one of the front axles is greater than that utilized by at least one of the rear axles.

4. REQUIREMENTS FOR SEMI-TRAILERS

4.1. For semi-trailers fitted with compressed-air braking systems:

4.1.1. The permissible relationship between the braking rate T_R/P_R and the pressure p_m shall lie within two areas derived from diagrams 4A and 4B for all pressures between 0.2 and 7.5 bar, in both the laden and unladen states of load. This requirement shall be met for all permissible load conditions of the semi-trailer axles.

4.1.2. If the requirements of paragraph 4.1.1. of this annex cannot be satisfied in conjunction with the requirements of paragraph 3.1.2.1. of annex 4 to this Regulation for semi-trailers with a K_c factor less than 0.80, then the semi-trailer must meet the minimum braking performance specified in paragraph 3.1.2.1. of annex 4 to this Regulation and be fitted with an anti-lock system complying with annex 13 to this Regulation, except the compatibility requirement in paragraph 1 of that annex.

5. REQUIREMENTS FOR FULL AND CENTRE-AXLE TRAILERS

5.1. For full trailers fitted with compressed-air braking systems:

5.1.1. The requirements set out in paragraph 3.1. of this annex shall apply to twin-axle trailers (except where the axle spread is less than 2 metres).

5.1.2. Full trailers with more than two axles shall be subject to the requirements of paragraph 3.2. of this annex.

5.1.3. The permissible relationship between the braking rate T_R/P_R and the pressure p_m shall lie within the designated areas in diagram 2 of this annex for all pressures between 0.2 and 7.5 bar, in both the laden and unladen states of load.

5.2. For centre-axle trailers fitted with compressed-air braking systems:

5.2.1. The permissible relationship between the braking rate T_R/P_R and the pressure p_m shall lie within two areas derived from diagram 2 of this annex, by multiplying the vertical scale by 0.95. This requirement shall be met at all pressures between 0.2 and 7.5 bar, in both the laden and unladen states of load.

5.2.2. If the requirements of paragraph 3.1.2.1. of annex 4 to this Regulation cannot be satisfied due to lack of adhesion, then the centre-axle trailer must be fitted with an anti-lock system complying with annex 13 to this Regulation.

6. REQUIREMENTS TO BE MET IN CASE OF FAILURE OF THE BRAKING DISTRIBUTION SYSTEM

When the requirements of this annex are fulfilled by means of a special device (e.g. controlled mechanically by the suspension of the vehicle), it shall be possible, in the event of the failure of its control, to stop the vehicle under the conditions specified for secondary braking in the case of power-driven vehicles; for those power-driven vehicles authorized to tow a trailer fitted with compressed-air braking systems, it must be possible to achieve a pressure at the coupling head of the control line within the range specified in paragraph 3.1.3. of this annex. In the event of failure of the control of the device on trailers, a service braking performance of at least 30 per cent of that prescribed for the vehicle in question shall be attained.

7. MARKINGS

7.1. Vehicles, other than those of category M_1 , which meet the requirements of this annex by means of a device mechanically controlled by the suspension of the vehicle, shall be marked to show the useful travel of the device between the positions corresponding to vehicle unladen and laden states, respectively, and any further information to enable the setting of the device to be checked.

7.1.1. When a brake load sensing device is controlled via the suspension of the vehicle by any other means, the vehicle must be marked with information to enable the setting of the device to be checked.

7.2. When the requirements of this annex are met by means of a device which modulates the air pressure in the brake transmission, the vehicle must be marked to show the axle loads at the ground, the nominal outlet pressures of the device and an inlet pressure of not less than 80 per cent of the maximum design inlet pressure, as declared by the vehicle manufacturer, for the following states of load:

7.2.1. technically permissible maximum axle load for the axle(s) which control(s) the device;

7.2.2. axle load(s) corresponding to the unladen mass of the vehicle in running order as stated in paragraph 13 of annex 2 to this Regulation;

7.2.3. The axle load(s) approximating to the vehicle with proposed bodywork in running order where the axle load(s) mentioned in paragraph 7.2.2. of this annex relate(s) to the vehicle chassis with cab;

- 7.2.4. The axle load(s) designated by the manufacturer to enable the setting of the device to be checked in service if this is (these are) different from the loads specified in paragraphs 7.2.1. to 7.2.3. of this annex.
- 7.3. Paragraph 14.7. of annex 2 to this Regulation must include information to enable compliance with the requirements of paragraphs 7.1. and 7.2. of this annex to be checked.
- 7.4. The markings referred to in paragraphs 7.1. and 7.2. of this annex must be affixed in a visible position in indelible form. An example of the markings for a mechanically controlled device in a vehicle fitted with compressed-air braking system is shown in diagram 5 of this annex.
- 7.5. Electronically controlled brake force distribution systems that cannot fulfil the requirements of paragraphs 7.1., 7.2., 7.3. and 7.4. above shall have a self checking procedure of the functions which influence brake force distribution.
8. VEHICLE TESTING
- During the type approval testing of a vehicle, the technical inspection authority shall verify conformity with the requirements contained in the present annex and carry out any further tests considered necessary to this end. The report on the additional tests shall be appended to the type approval form.

DIAGRAM 1A

VEHICLES OF CATEGORY M₁
(and certain vehicles of category N₁ after 1 October 1990)
(see paragraph 3.1.2.1. of this annex)

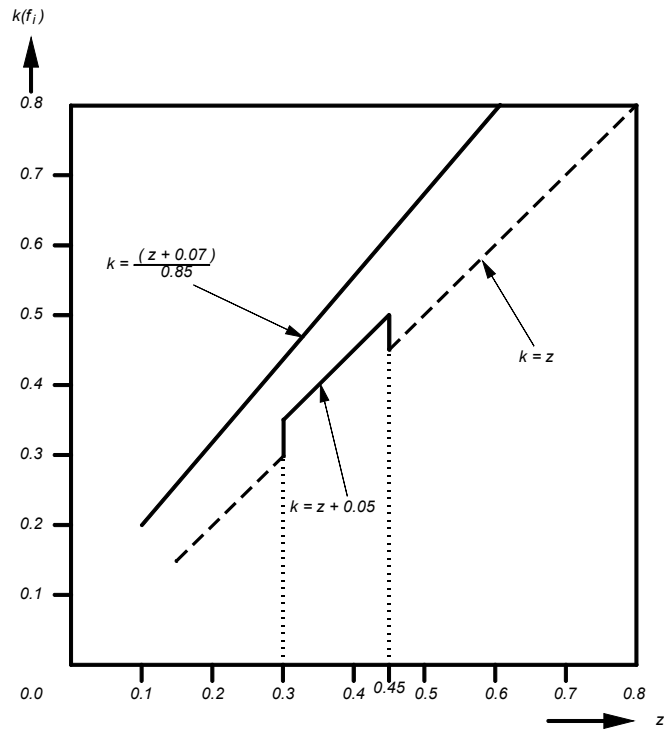
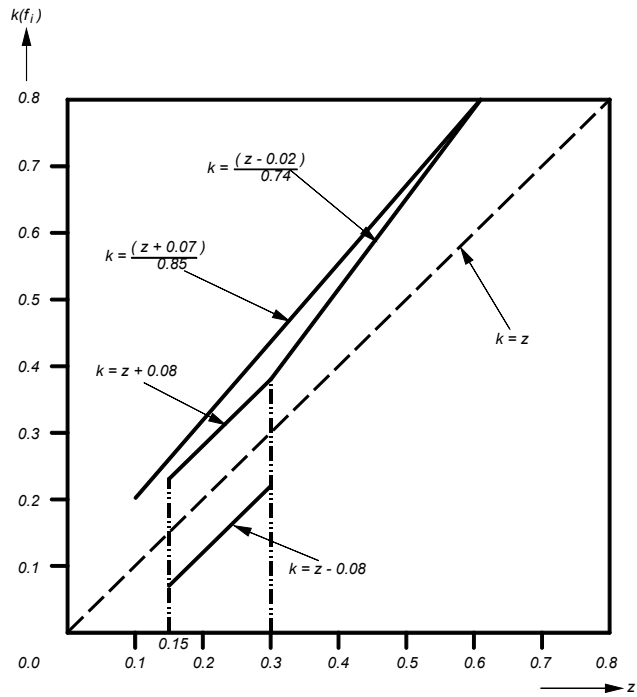

DIAGRAM 1B

POWER-DRIVEN VEHICLES OTHER THAN THOSE OF CATEGORIES M₁ AND N₁
(see paragraph 3.1.2.3. of this annex)



Note: The lower limit $k = z - 0.08$ is not applicable for the adhesion utilization of the rear axle.

DIAGRAM 1C

VEHICLES OF CATEGORY N₁
 (with certain exceptions after 1 October 1990)
 (see paragraph 3.1.2.2. of this annex)

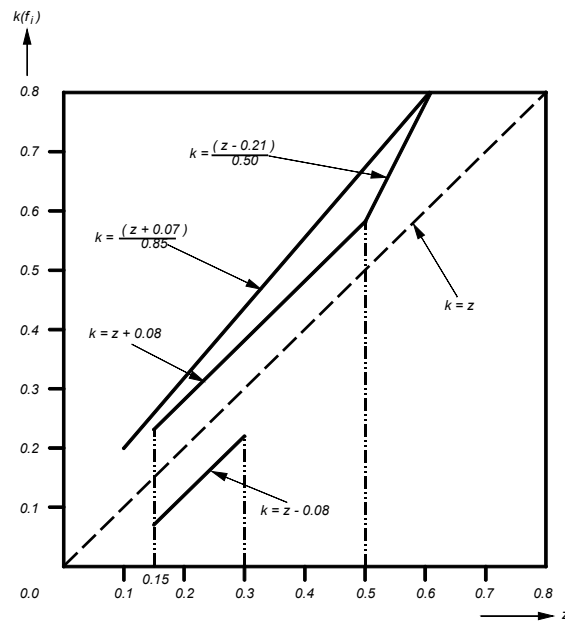

Note: The lower limit $k = z - 0.08$ is not applicable for the adhesion utilization of the rear axle.

DIAGRAM 2

TOWING VEHICLES AND TRAILERS

(except tractors for semi-trailers and semi-trailers)
 (see paragraph 3.1.5.1. of this annex)

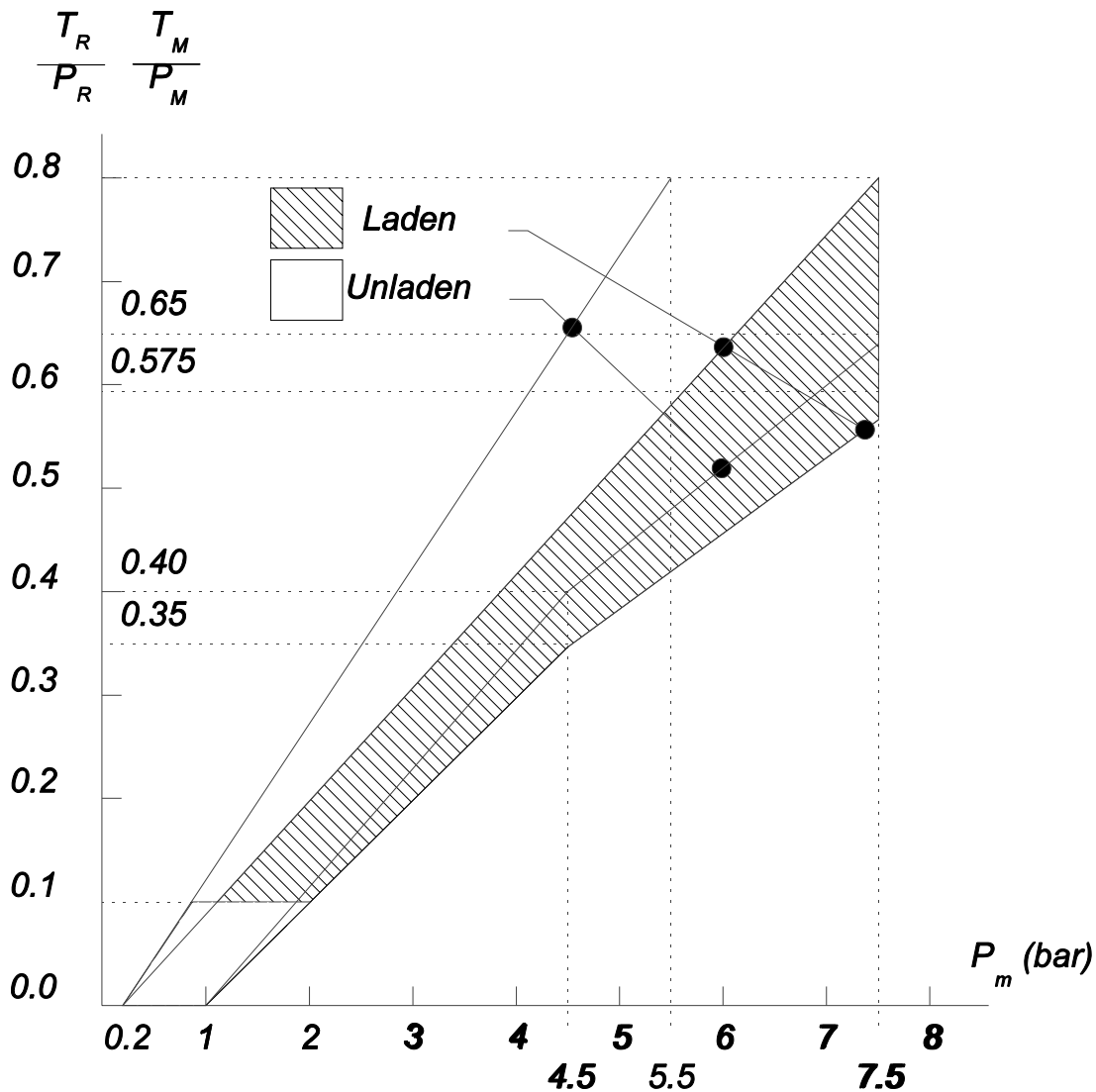

No The relationships required by the diagram shall apply progressively for te: intermediate states of loading between the laden and the unladen states and shall be achieved by automatic means.

DIAGRAM 3

TRACTORS FOR SEMI-TRAILERS

(see paragraph 3.1.6. of this annex)

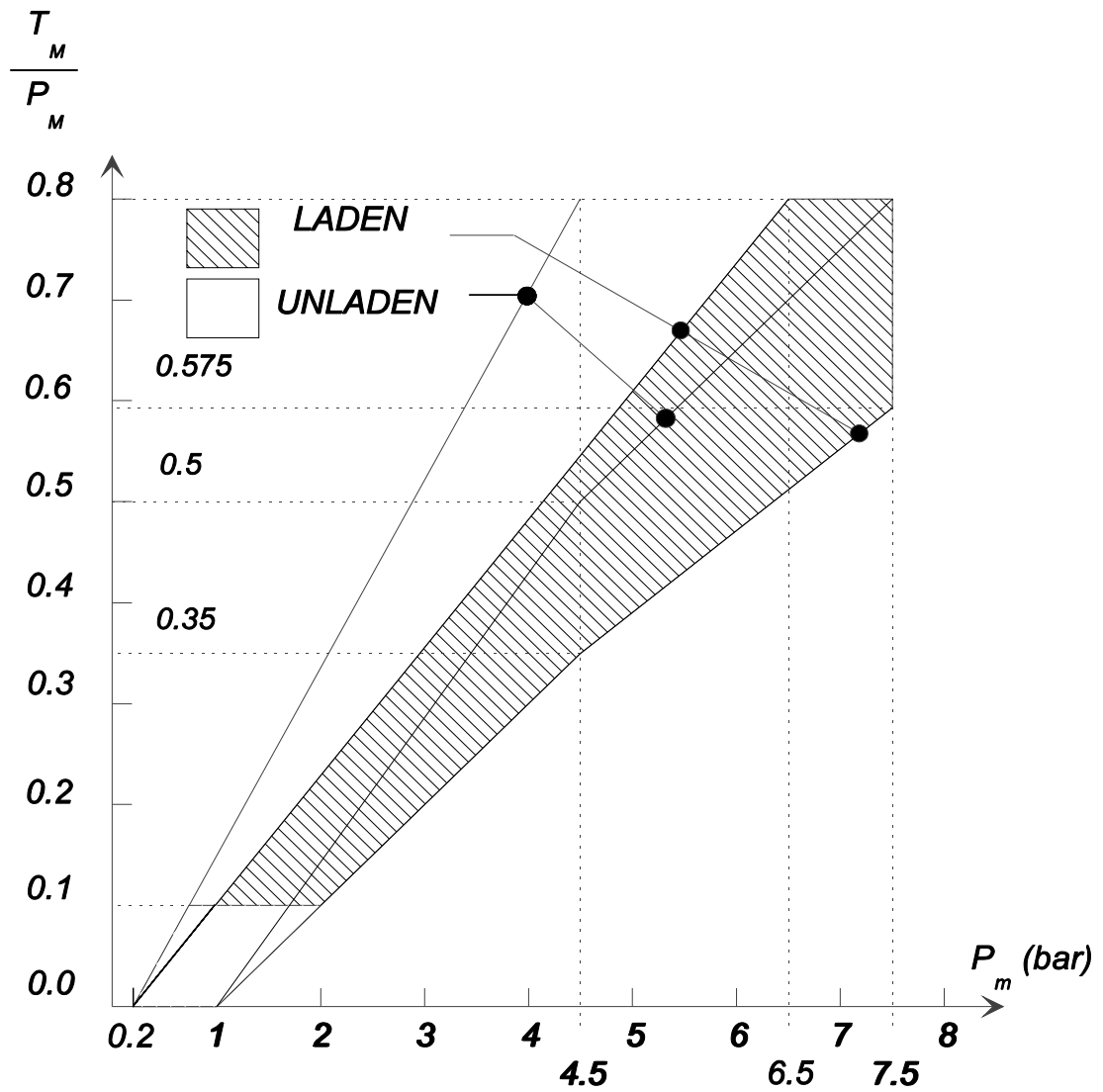

Not
 The
 lat
 nsh
 s

quired by the diagram shall apply progressively for intermediate states of loading between the laden and the unladen states and shall be achieved by automatic means.

e:
 re
 io
 ip
 re

DIAGRAM 4A

SEMI-TRAILERS
 (see paragraph 4 of this annex)

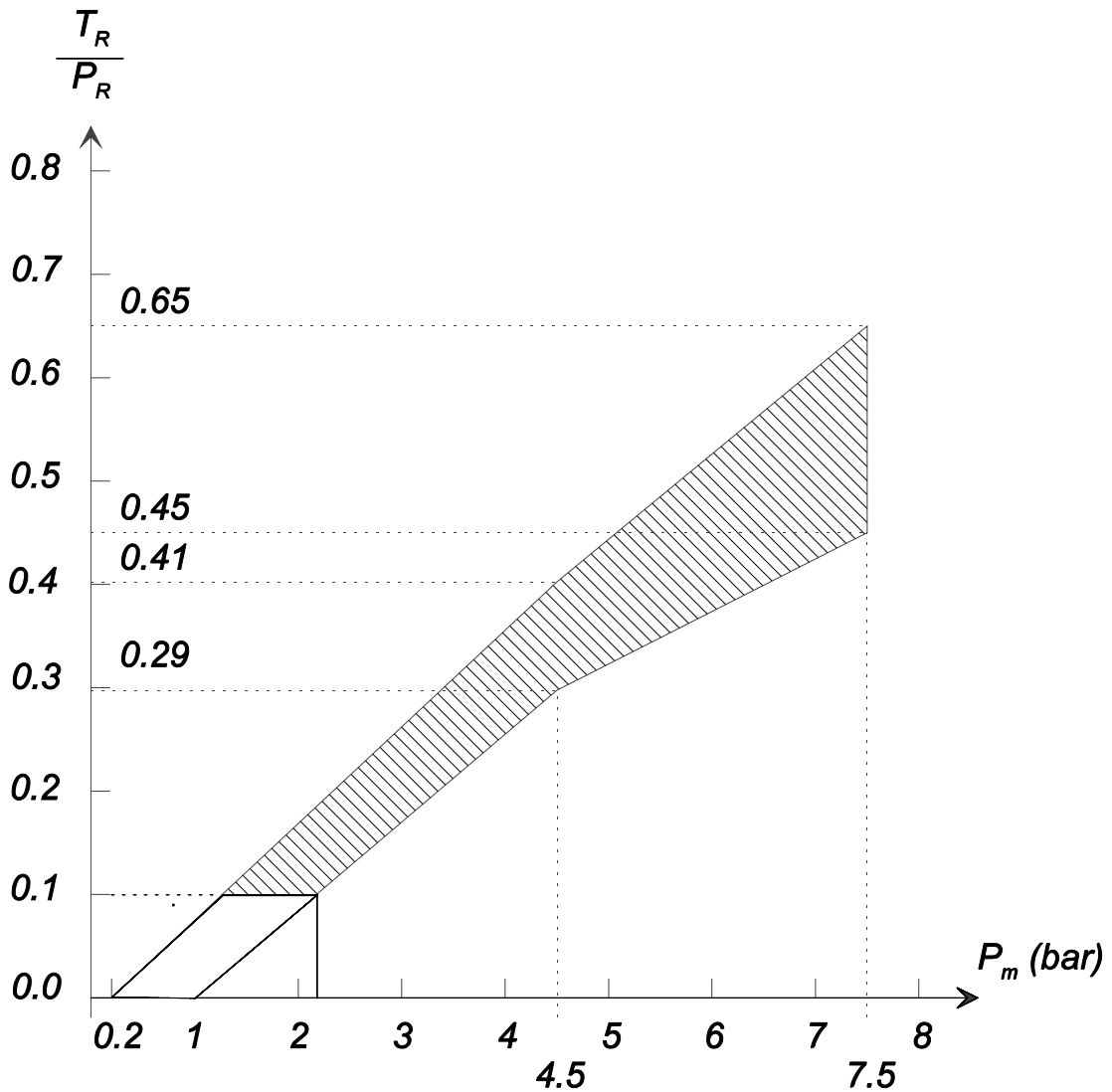

Not
 The
 ati

between the braking rate T_R/P_R and the control line pressure for the laden and unladen conditions is determined as follows:

e:
 rel
 on

The factors K_c (laden), K_v (unladen) are obtained by reference to diagram 4B. To determine the areas corresponding to the laden and unladen conditions, the values of the ordinates of the upper and lower limits of the hatched area in diagram 4A are multiplied by the factors K_c and K_v respectively.

DIAGRAM 4B

(see paragraph 4 and diagram 4A of this annex)

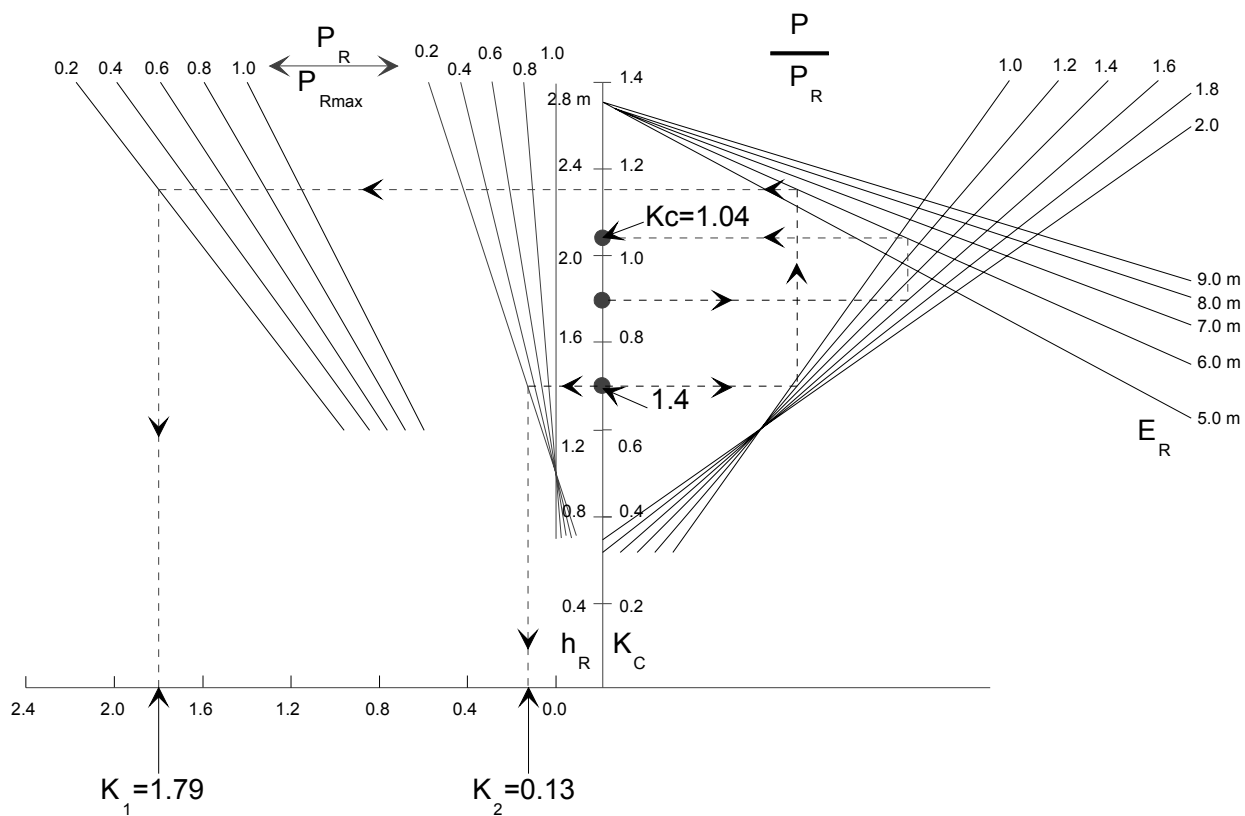

EXPLANATORY NOTE ON THE USE OF DIAGRAM 4B

1. Formula from which diagram 4B is derived:

$$K = \left[1.7 - \frac{0.7 P_R}{P_{Rmax}} \right] \left[1.35 - \frac{0.96}{E_R} \left(1.0 + (h_R - 1.2) \frac{g \cdot P}{P_R} \right) \right] - \left[1.0 - \frac{P_R}{P_{Rmax}} \right] \left[\frac{h_R - 1.0}{2.5} \right]$$

2.

Description of method of use with practical example.

2.1. The broken lines shown on diagram 4B refer to the determination of the factors K_c and K_v for the following vehicle, where:

	Laden	Unladen
P	24 tonnes (240 kN)	4.2 tonnes (42 kN)
P_R	150 kN	30 kN
P_{Rmax}	150 kN	150 kN
h_R	1.8 m	1.4 m
E_R	6.0 m	6.0 m

In the following paragraphs the figures in parentheses relate only to the vehicle being used for the purpose of illustrating the method of using diagram 4B.

2.2. Calculation of ratios

$$(a) \left[\frac{g \cdot P}{P_R} \right] \text{ laden } (=1.6)$$

$$(b) \left[\frac{g \cdot P}{P_R} \right] \text{ unladen } (=1.4)$$

$$(c) \left[\frac{P_R}{P_{Rmax}} \right] \text{ unladen } (=0.2)$$

2.3. Determination of the correction factor when laden, K_c :

- Start at the appropriate value of h_R ($h_R = 1.8$ m)
- Move horizontally to the appropriate $g \cdot P/P_R$ line ($g \cdot P/P_R = 1.6$)
- Move vertically to the appropriate E_R line ($E_R = 6.0$ m)
- Move horizontally to the K_c scale; K_c is the laden correction factor required ($K_c = 1.04$)

2.4. Determination of the correction factor when unladen, K_v :

2.4.1. Determination of the factor K_2 :

- (a) Start at appropriate h_R ($h_R = 1.4$ m)
- (b) Move horizontally to the appropriate P_R/P_{Rmax} line in the group of curves nearest to vertical axis ($P_R/P_{Rmax} = 0.2$)
- (c) Move vertically to the horizontal axis and read off the value of K_2 ($K_2 = 0.13$ m).

2.4.2. Determination of the factor K_1 :

- (a) Start at the appropriate value of h_R ($h_R = 1.4$ m)
- (b) Move horizontally to the appropriate $g \cdot P/P_R$ line ($g \cdot P/P_R = 1.4$)
- (c) Move vertically to the appropriate E_R line ($E_R = 6.0$ m)
- (d) Move horizontally to the appropriate P_R/P_{Rmax} line in the group of curves furthest from the vertical axis ($P_R/P_{Rmax} = 0.2$)
- (e) Move vertically to the horizontal axis and read off the value of K_1 ($K_1 = 1.79$).

2.4.3. Determination of the factor K_v :

The unladen correction factor K_v is obtained from the following expression:

$$K_v = K_1 - K_2 \quad (K_v = 1.66)$$

DIAGRAM 5

BRAKE LOAD SENSING DEVICE
 (see paragraph 7.4. of this annex)

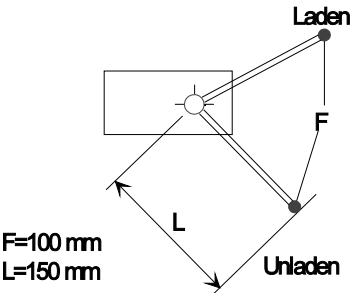
Control data	Vehicle loading	Axle No.2 load at the ground [daN]	Inlet pressure [bar]	Nominal outlet pressure [bar]
 <p>F=100 mm L=150 mm</p>	<p>Laden Unladen</p>	<p>10 000 1 500</p>	<p>6 6</p>	<p>6 2.4</p>

Annex 11

CASES IN WHICH TYPE-I AND/OR TYPE-II (OR TYPE-IIA) OR TYPE-III TESTS
DO NOT HAVE TO BE CARRIED OUT

1. Type-I and/or Type-II (or Type-IIA) or Type-III tests need not be performed on a vehicle submitted for approval in the following cases:
 - 1.1. The vehicle concerned is a power-driven vehicle or a trailer which, as regards tyres, braking energy absorbed per axle, and mode of tyre fitting and brake assembly, is identical with respect to braking with a power-driven vehicle or a trailer which:
 - 1.1.1. has passed the Type-I and/or Type-II (or Type-IIA) or Type-III test; and
 - 1.1.2. has been approved, with regard to the braking energy absorbed, for mass per axle not lower than that of the vehicle concerned.
 - 1.2. The vehicle concerned is a power-driven vehicle or a trailer whose axle or axles are, as regards tyres, braking energy absorbed per axle, and mode of tyre fitting and brake assembly, identical with respect to braking with an axle or axles which have individually passed the Type-I and/or Type-II (or Type-IIA) or Type-III test for masses per axle not lower than that of the vehicle concerned, provided that the braking energy absorbed per axle does not exceed the energy absorbed per axle in the reference test or tests carried out on the individual axle.
 - 1.3. The vehicle concerned is equipped with an endurance braking system, other than the engine brake, identical with an endurance braking system already tested under the following conditions:
 - 1.3.1. the endurance braking system shall, by itself, in a test carried out on a gradient of at least 6 per cent (Type-II test) or of at least 7 per cent (Type-IIA test), have stabilized a vehicle whose maximum mass at the time of the test was not less than the maximum mass of the vehicle submitted for approval;
 - 1.3.2. it shall be verified in the above test that the rotational speed of the rotating parts of the endurance braking system, when the vehicle submitted for approval reaches a road speed of 30 km/h, is such that the retarding torque is not less than that corresponding to the test referred to in paragraph 1.3.1. above.
 - 1.4. The vehicle concerned is a trailer equipped with S-cam air operated brakes 1/ which satisfies the verification requirements of appendix 2 to this annex relative to the control of characteristics compared to the characteristics given in a report of a reference axle test as shown in appendix 3 to this annex.
2. The term "identical", as used in paragraphs 1.1., 1.2. and 1.3. above,

1/ Other brake designs may be approved upon presentation of equivalent information.

means identical as regards the geometric and mechanical characteristics and the materials used for the components of the vehicle referred to in those paragraphs.

3. Where the foregoing requirements are applied, the communication concerning approval (annex 2 to this Regulation) shall include the following particulars:
 - 3.1. In the case under paragraph 1.1., the approval number of the vehicle subjected to the Type-I and/or Type-II (or Type-IIA) or Type-III test of reference shall be entered.
 - 3.2. In the case under paragraph 1.2., Table I in appendix 1 to this annex shall be completed;
 - 3.3. In the case under paragraph 1.3., Table II in appendix 1 to this annex shall be completed.
 - 3.4. If paragraph 1.4. is applicable, Table III in appendix 1 to this annex shall be completed.
 4. Where the applicant for approval in a country Party to the Agreement applying this Regulation refers to an approval granted in another country Party to the Agreement applying this Regulation, he shall submit the documentation relating to that approval.
-

Annex 11 - Appendix 1

Table I

	Axles of the vehicle			Reference axles		
	Mass per axle <u>1</u> /	Braking force needed at wheels	Speed	Mass per axle <u>1</u> /	Braking force developed at wheels	Speed
	kg	N	km/h	kg	N	km/h
Axle 1						
Axle 2						
Axle 3						
Axle 4						

Table II

Total mass of the vehicle submitted for approval	kg
Braking force needed at wheels	N
Retarding torque needed at main shaft of endurance braking system	Nm
Retarding torque obtained at main shaft of endurance braking system (according to diagram)	Nm

1/ Technically permissible maximum mass per axle.

Table III

Reference axle	Report No.	Date	
		(copy attached)	
		Type-I	Type-III
Energy absorbed per axle (N) (see paragraph 4.2.1., appendix 2)			
Axle 1	$T_1 = \dots \% P_e$	$T_1 = \dots \% P_e$	$T_1 = \dots \% P_e$
Axle 2	$T_2 = \dots \% P_e$	$T_2 = \dots \% P_e$	$T_2 = \dots \% P_e$
Axle 3	$T_3 = \dots \% P_e$	$T_3 = \dots \% P_e$	$T_3 = \dots \% P_e$
Predicted actuator stroke (mm) (see paragraph 4.3.2., appendix 2)			
Axle 1	$s_1 = \dots$	$s_1 = \dots$	$s_1 = \dots$
Axle 2	$s_2 = \dots$	$s_2 = \dots$	$s_2 = \dots$
Axle 3	$s_3 = \dots$	$s_3 = \dots$	$s_3 = \dots$
Average output thrust (N) (see paragraph 4.3.3., appendix 2)			
Axle 1	$Th_{A1} = \dots$	$Th_{A1} = \dots$	$Th_{A1} = \dots$
Axle 2	$Th_{A2} = \dots$	$Th_{A2} = \dots$	$Th_{A2} = \dots$
Axle 3	$Th_{A3} = \dots$	$Th_{A3} = \dots$	$Th_{A3} = \dots$
Braking performance (N) (see paragraph 4.3.5., appendix 2)			
Axle 1	$T_1 = \dots$	$T_1 = \dots$	$T_1 = \dots$
Axle 2	$T_2 = \dots$	$T_2 = \dots$	$T_2 = \dots$
Axle 3	$T_3 = \dots$	$T_3 = \dots$	$T_3 = \dots$
Braking performance of vehicle (see paragraph 4.3.6., appendix 2)	Type-0 subject trailer test result (E)	Type-I hot (predicted)	Type-III hot (predicted)
Hot braking requirements (see paragraphs 1.5.3., 1.6.3. and 1.7.2. of annex 4)		≥ 0.36 and $\geq 0.60 E$	≥ 0.40 and $\geq 0.60 E$

Annex 11 - Appendix 2

ALTERNATIVE PROCEDURES FOR TYPE-I AND TYPE-III TESTS FOR TRAILER BRAKES

1. GENERAL

- 1.1. In accordance with paragraph 1.4. of this annex, the Type-I or Type-III test may be waived at the time of type approval of the vehicle provided that the braking system components comply with the requirements of this appendix and that the resulting predicted braking performance meets the requirements of this Regulation for the appropriate vehicle category.
- 1.2. Tests carried out in accordance with the methods detailed in this appendix shall be deemed to meet the above requirements.

2. SYMBOLS AND DEFINITIONS

Note: The reference brake symbols shall have the suffix "e"

P	=	normal reaction of road surface on the axle under static conditions
C	=	camshaft input torque
C_{\max}	=	maximum technically permissible camshaft input torque
C_o	=	threshold camshaft input torque, i.e., minimum camshaft torque necessary to produce a measurable brake torque
R	=	tyre rolling radius (dynamic)
T	=	brake force at tyre/road interface
M	=	brake torque = T.R
z	=	braking rate = T/P or M/RP
s	=	actuator stroke (working stroke plus free stroke)
s_p	=	effective stroke - the stroke at which the output thrust is 90 per cent of the average thrust (Th_a)
Th_a	=	average thrust - the average thrust is determined by integrating the values between one third and two thirds of the total stroke (s_{\max})
l	=	lever length
r	=	radius of brake drums
p	=	brake actuation pressure

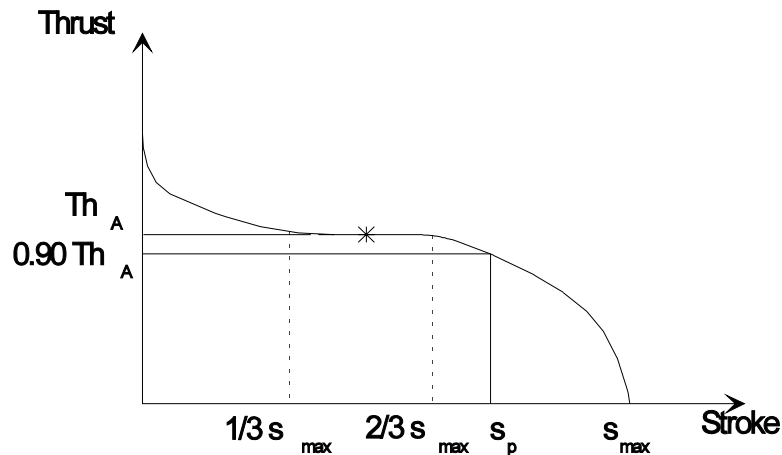

3. TEST METHODS
- 3.1. Track tests
- 3.1.1. The brake performance tests should preferably be carried out on a single axle only.
- 3.1.2. The results of tests on a combination of axles may be used in accordance with paragraph 1.1. of this annex provided that each axle contributes equal braking energy input during the drag and hot brake tests.
- 3.1.2.1. This is ensured if the following are identical for each axle: braking geometry, lining, wheel mounting, tyres, actuation and pressure distribution in the actuators.
- 3.1.2.2. The documented result for a combination of axles will be the average for the number of axles, as though a single axle had been used.
- 3.1.3. The axle(s) should preferably be loaded with the maximum static axle load, though this is not essential provided that due allowance is made during the tests for the difference in rolling resistance caused by a different load on the test axle(s).
- 3.1.4. Allowance shall be made for the effect of the increased rolling resistance resulting from a combination of vehicles being used to carry out the tests.
- 3.1.5. The initial speed of the test shall be that prescribed. The final speed shall be calculated by the following formula:

$$v_2 = v_1 \sqrt{\frac{P_o + P_1}{P_o + P_1 + P_2}}$$

where

v_1 = initial speed (km/h)

v_2 = final speed (km/h)

P_o = mass of the towing vehicle (kg) under test conditions

P_1 = part of the mass of the trailer borne by the unbraked axle(s) (kg)

P_2 = part of the mass of the trailer borne by the braked axle(s) (kg).

3.2. Inertia dynamometer tests

3.2.1. The test machine shall have a rotary inertia simulating that part of the linear inertia of the vehicle mass acting upon one wheel, necessary for the cold performance and hot performance tests, and capable of being operated at constant speed for the purpose of the test described in paragraphs 3.5.2. and 3.5.3. of this appendix.

3.2.2. The test shall be carried out with a complete wheel, including the tyre, mounted on the moving part of the brake, as it would be on the vehicle. The inertia mass may be connected to the brake either directly or via the tyres and wheels.

3.2.3. Air cooling at a velocity and air flow direction simulating actual conditions may be used during the heating runs, the speed of air flow being not greater than 10 km/h. The temperature of the cooling air shall be the ambient temperature.

3.2.4. Where the tyre rolling resistance is not automatically compensated for in the test, the torque applied to the brake shall be modified by subtracting a torque equivalent to a rolling resistance coefficient of 0.01.

3.3. Rolling road dynamometer tests

3.3.1. The axle should preferably be loaded with the maximum static axle mass though this is not essential provided that due allowance is made during the tests for the difference in rolling resistance caused by a different mass on the test axle.

3.3.2. Air cooling at a velocity and air flow direction simulating actual conditions may be used during the heating runs, the speed of air flow being not greater than 10 km/h. The temperature of the cooling air shall be the ambient temperature.

3.3.3. The braking time shall be 1 second after a maximum build-up time of 0.6 second.

3.4. Test conditions

- 3.4.1. The test brake(s) shall be instrumented so that the following measurements can be taken:
 - 3.4.1.1. A continuous recording to enable the brake torque or force at the periphery of the tyre to be determined.
 - 3.4.1.2. A continuous recording of air pressure in the brake actuator.
 - 3.4.1.3. Vehicle speed during the test.
 - 3.4.1.4. Initial temperature on the outside of the brake drum.
 - 3.4.1.5. Brake actuator stroke used during Type-0 and Type-I or Type-III tests.
- 3.5. Test procedures
 - 3.5.1. Supplementary cold performance test
 - 3.5.1.1. This test is carried out at an initial speed equivalent to 40 km/h in the case of Type-I test and 60 km/h in the case of Type-III test in order to evaluate the hot braking performance at the end of Type-I and Type-III tests.
 - 3.5.1.2. Three brake applications are made at the same pressure (p) and at an initial speed equivalent to 40 km/h (in the case of Type-I test) or 60 km/h (in the case of Type-III test), with an approximately equal initial brake temperature not exceeding 100°C, measured at the outside surface of the drums. The applications shall be at the brake actuator pressure required to give a brake torque or force equivalent to a braking rate (z) of at least 50 per cent. The brake actuator pressure shall not exceed 6.5 bar, and the camshaft input torque (C) shall not exceed the maximum technically permissible

camshaft input torque (C_{max}). The average of the three results shall be taken as the cold performance.

3.5.2. Fade test (Type-I test)

3.5.2.1. This test is carried out at a speed equivalent to 40 km/h with an initial brake temperature not exceeding 100°C, measured at the outside surface of the drum.

3.5.2.2. A braking rate is maintained at 7 per cent, including the rolling resistance (see paragraph 3.2.4. of this appendix).

3.5.2.3. The test is made during 2 minutes and 33 seconds or during 1.7 km at a vehicle speed of 40 km/h. If the test velocity cannot be achieved, then the duration of the test can be lengthened according to paragraph 1.5.2.2. of annex 4 to this Regulation.

3.5.2.4. Not later than 60 seconds after the end of the Type-I test, a hot performance test is carried out in accordance with paragraph 1.5.3. of annex 4 to this Regulation at an initial speed equivalent to 40 km/h. The brake actuator pressure shall be that used during the Type-0 test.

3.5.3. Fade test (Type-III test)

3.5.3.1. Test methods for repeated braking

3.5.3.1.1. Track tests (see annex 4, paragraph 1.7)

3.5.3.1.2. Inertia dynamometer test

For the bench test as in annex 11, appendix 2, paragraph 3.2., the conditions may be as for the road test according to paragraph 1.7.1. with:

$$v_2 = \frac{v_1}{2}$$

3.5.3.1.3. Rolling road dynamometer test

For the bench test as in annex 11, appendix 2, paragraph 3.3., the conditions shall be as follows:

Number of brake applications	20
Duration of braking cycle (braking time 25 s and recovery time 35 s)	60 s
Test speed	30 km/h
Braking rate	0.06
Rolling resistance	0.01

3.5.3.2. Not later than 60 seconds after the end of the Type-III test a hot performance test is carried out in accordance with paragraph 1.7.2. of annex 4 to this Regulation. The brake actuator pressure shall be that used during the Type-0 test.

3.6. Test report

3.6.1. The result of tests carried out in accordance with paragraph 3.5. of this appendix shall be reported on a form, a model of which is shown in appendix 3 to this annex.

3.6.2. The brake and the axle shall be identified. Particulars of the brakes, the axle, the technically permissible mass and the number of the corresponding test report shall be marked on the axle.

4. VERIFICATION

4.1. Verification of components

The brake specification of the vehicle to be type approved shall be verified by satisfying each of the following design criteria:

Item	Criteria
4.1.1.(a) Brake drum cylindrical section	No change allowed
(b) Brake drum material	No change allowed
(c) Brake drum mass	May increase up to +20 per cent from the reference drum mass
4.1.2.(a) Proximity of wheel to outside surface of brake drum (dimension E)	Tolerances to be determined by the Technical Service conducting the approval tests
(b) Part of brake drum not covered by wheel (dimension F)	
4.1.3.(a) Brake lining material)
(b) Brake lining width)
(c) Brake lining thickness)
(d) Brake lining actual surface area)No change allowed
(e) Brake lining method of attachment)
4.1.4. Brake geometry (as in Fig.2 of appendix 3)	No change allowed
4.1.5. Tyre rolling radius (R)	May change subject to the requirements of para. 4.3.5. of this appendix
4.1.6.(a) Average thrust (T_h)	May change provided that the predicted performance meets the requirements of para. 4.3. of this appendix
(b) Actuation stroke (s)	
(c) Actuation lever length (l)	
(d) Actuation pressure (p)	
4.1.7. Static mass (P)	P shall not exceed P_e (see para. 2)

4.2. Verification of brake energy absorbed

4.2.1. The brake forces (T) for each subject brake (for the same control line pressure p_m) necessary to produce the drag force specified for both Type-I and Type-III test conditions must not exceed the values T_e as stated in annex 11 - appendix 3, paragraphs 2.1. and 2.2., which were taken as a basis for the test of the reference brake.

4.3. Verification of hot performance

4.3.1. The brake force (T) for each subject brake for a specified pressure (p) in the actuators and for a control line pressure (p_m) used during the Type-0 test of the subject trailer is determined as follows:

4.3.1.1. The predicted actuator stroke (s) of the subject brake is calculated

as follows:

$$s = l \cdot \frac{s_e}{l_e}$$

This value should not exceed s_p .

4.3.1.2. The average thrust output (Th_A) of the actuator fitted to the subject brake at the pressure specified in paragraph 4.3.1. above is measured.

4.3.1.3. The camshaft input torque (C) is then calculated as follows:

$$C = Th_A \cdot l$$

C shall not exceed C_{max} .

4.3.1.4. The predicted brake performance for the subject brake is given by:

$$T = (T_c - 0.01 \cdot P_c) \frac{(C - C_o)}{(C_c - C_{oc})} \cdot \frac{R_c}{R} + 0.01 \cdot P$$

R shall not be less than $0.8 R_e$.

4.3.2. The predicted brake performance for the subject trailer is given by:

$$\frac{T_R}{P_R} = \frac{\sum T}{\sum P}$$

4.3.
3.

The hot performances following the Type-I or Type-III tests shall be determined in accordance with paragraphs 4.3.1.1. to 4.3.1.4. The resulting predictions given by paragraph 4.3.2. above must satisfy the requirements of this Regulation for the subject trailer. The value used for "the figure recorded in the Type-0 test as prescribed in paragraph 1.5.3. or 1.7.2. of annex 4", shall be the figure recorded in the Type-0 test of the subject trailer.

Annex 11 - Appendix 3

MODEL TEST REPORT FORM AS PRESCRIBED IN PARAGRAPH 3.6. OF
APPENDIX 2 TO THIS ANNEX

TEST REPORT NO.

1. IDENTIFICATION

1.1. Axle:

Manufacturer (name and address)

Make

Type

Model

Technically permissible axle load (P_e) daN

1.2. Brake:

Manufacturer (name and address)

Make

Type

Model

Technically permissible camshaft input torque C_{max}

Brake drum:

Internal diameter

Mass

Material (attach dimensioned drawing as in fig. 1 to this
appendix)

Brake lining:

Manufacturer

Type

Identification (must be visible when the lining is mounted on the
brake shoe)

Width

Thickness

Surface area

Method of attachment

Brake geometry (attach dimensioned drawing as in fig. 2 to this
appendix)

- 1.3. Wheel(s):
Single/Twin 1/
Rim diameter (D)
(attach dimensioned drawing as in fig. 1 to this appendix)
- 1.4. Tyres:
Reference rolling radius (R_e) at reference reaction (P_e)
- 1.5. Actuator:
Manufacturer
Type (cylinder/diaphragm) 1/
Model
Lever length (l_e)
2. RECORD OF TEST RESULTS 2/
(corrected to take account of rolling resistance $\Rightarrow 0,01 \cdot P_e$)
- 2.1. In the case of vehicles of categories O_2 and O_3 :

Test type:		0	I	
Annex 11, appendix 2, para.:		3.5.1.2.	3.5.2.2./3.	3.5.2.4.
Test speed	km/h	40	40	40
Brake actuator pressure p_e	bar		-	-
Braking time	min	-	2.55	-
Brake force developed T_e	N			
Brake efficiency $T_e/9,81P_e$	-			
Actuator stroke s_e	mm		-	
Camshaft input torque C_e	Nm		-	
$C_{\alpha e}$	Nm		-	

1/ Strike out what does not apply.

2/ Track Test/Inertia Dynamometer Test/Rolling Road Dynamometer Test
(delete where not applicable)

2.2. In the case of vehicles of category O₄:

Test type:		0	III	
Annex 11, appendix 2, para.:		3.5.1.2.	3.5.3.1.	3.5.3.2.
Test speed initial	km/h	60		60
Test speed final	km/h			
Brake actuator pressure p_e	bar		-	
Number of brake applications	-	-	20	-
Duration of braking cycle	s	-	60	-
Brake force developed T_e	N			
Brake efficiency $T_e/9,81P_e$	-			
Actuator stroke s_e	mm		-	
Camshaft input torque C_e	Nm		-	
$C_{a,e}$	Nm		-	

3. Name of Technical Service conducting the test:

4. Date of test:

5. This test has been carried out and the result reported in accordance with ECE Regulation No. 13, paragraph 4 and annex 11, appendix 2.

SIGNED

DATE

Figure 2

BRAKE GEOMETRY

l = variable possible lengths (mm)

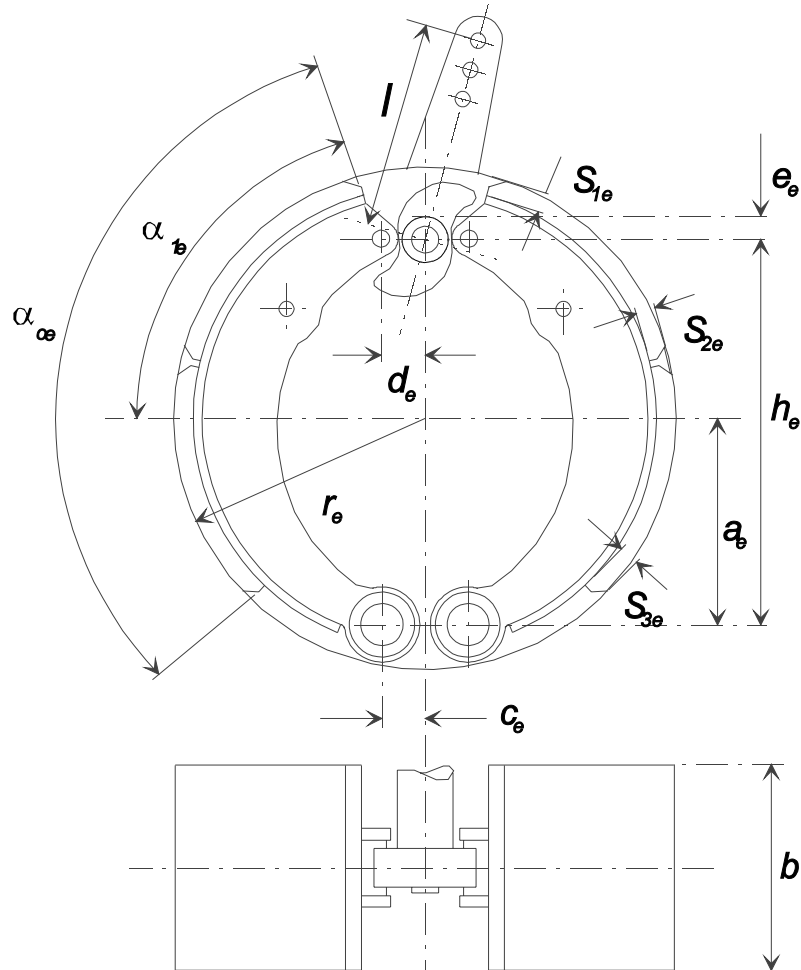

All dimensions in mm except α_{oe} , α_{1e} and F_e .

F_e = useful braking surface per brake (cm²).

Type of brake	a_e	h_e	c_e	d_e	e_e	α_{oe}	α_{1e}	b_e	r_e	F_e	S_{1e}	S_{2e}	S_{3e}

Annex 12

CONDITIONS GOVERNING THE TESTING OF VEHICLES EQUIPPED WITH INERTIA (OVERRUN) BRAKING SYSTEMS

1. GENERAL PROVISIONS

- 1.1. The inertia (overrun) braking system of a trailer comprises the control device, the transmission and the wheel brakes, hereinafter called "brakes".
- 1.2. The control device is the aggregate of the components integral with the traction device (coupling head).
- 1.3. The transmission is the aggregate of the components comprised between the last part of the coupling head and the first part of the brake.
- 1.4. The "brake" is the part in which the forces opposing the movement of the vehicle develop. The first part of the brake is either the lever actuating the brake cam or similar components (mechanical-transmission inertia braking system), or the brake cylinder (hydraulic-transmission inertia braking system).
- 1.5. Braking systems in which accumulated energy (e.g. electric, pneumatic or hydraulic energy) is transmitted to the trailer by the towing vehicle and is controlled only by the thrust on the coupling do not constitute inertia braking systems within the meaning of this Regulation.
- 1.6. Tests
- 1.6.1. Determination of essential components of the brake.
- 1.6.2. Determination of essential components of the control device and verification of the latter's conformity with the provisions of this Regulation.
- 1.6.3. Checking on the vehicle:
- (a) the compatibility of the control device and the brake; and
 - (b) the transmission.

2. SYMBOLS AND DEFINITIONS

- 2.1. Units used
- 2.1.1. Mass: kg;
- 2.1.2. Force: N;
- 2.1.3. Acceleration due to gravity: $g = 10 \text{ m/s}^2$
- 2.1.4. Torques and moments: Nm;
- 2.1.5. Areas: cm^2 ;
- 2.1.6. Pressures: bar;
- 2.1.7. Lengths: unit specified in each case.
- 2.2. Symbols valid for all types of brakes (see Figure 1 of appendix 1 to this annex)
- 2.2.1. G_A : trailer's technically permissible "maximum mass" as declared by the manufacturer;
- 2.2.2. G'_A : trailer's "maximum mass" capable of being braked by the control

device, as declared by the manufacturer;

- 2.2.3. G_B : trailer's "maximum mass" capable of being braked by joint operation of all of the trailer's brakes
- $$G_B = n \cdot G_{B_0} ;$$
- 2.2.4. G_{B_0} : fraction of trailer's permissible "maximum mass" capable of being braked by one brake, as declared by the manufacturer;
- 2.2.5. B^* : required braking force;
- 2.2.6. B : required braking force taking account of rolling resistance;
- 2.2.7. D^* : permissible thrust on coupling;
- 2.2.8. D : thrust on coupling;
- 2.2.9. P' : control device output force;
- 2.2.10. K : supplementary force of control device, conventionally designated by the force D corresponding to the point of intersection with the axis of the abscissae of the extrapolated curve expressing P' in terms of D , measured with the device in the mid-travel position (see Figures 2 and 3 of appendix 1 to this annex);
- 2.2.11. K_A : stress threshold of control device, i.e., the maximum thrust on the coupling head which can be applied for a short time without placing any stress on the output side of the control device. The symbol K_A is conventionally applied to the force measured when the coupling head begins to be pushed home at a speed of 10 to 15 mm/s, the control device transmission being uncoupled;
- 2.2.12. D_1 : the maximum force applied to the coupling head when it is being pushed home at a speed of s mm/s \pm 10 per cent, the transmission being uncoupled;
- 2.2.13. D_2 : the maximum force applied to the coupling head when it is being pulled at a speed of s mm/s \pm 10 per cent out of the position of maximum compression, the transmission being uncoupled;
- 2.2.14. η_{H_0} : efficiency of inertia control device;
- 2.2.15. η_{H_1} : efficiency of transmission system;
- 2.2.16. η_H : overall efficiency of control device and transmission
 $\eta_H = \eta_{H_0} \cdot \eta_{H_1}$;
- 2.2.17. s : travel of control in millimetres;
- 2.2.18. s' : effective (useful) travel of control in millimetres, determined as required by paragraph 9.4.1. of this annex;
- 2.2.19. s'' : spare travel of master cylinder, measured in millimetres at coupling head;
- 2.2.20. s_0 : loss of travel, i.e., travel in millimetres of the coupling head when the latter is so actuated as to move from 300 mm above to 300 mm below the horizontal, the transmission remaining stationary;
- 2.2.21. $2s_B$: brake-shoe lift (brake-shoe application travel), in millimetres, measured on diameter parallel to applying device, the brakes not

being adjusted during the test;

- 2.2.22. $2s_B^*$: Minimum brake shoe centre lift (minimum brake shoe application travel) (in millimetres) for wheel brakes with drum brakes

$$2s_B^* = 2.4 + \frac{4}{1000} \cdot 2r$$

$2r$ being the diameter of the brake drum in millimetres;
 (see appendix 1, Figure 4, to this annex)

for wheel brakes with disc brakes with hydraulic transmission

$$2s_B^* = 1.1 \cdot \frac{10 \cdot V_{60}}{F_{RZ}} + \frac{1}{1000} \cdot 2r_A$$

where:

V_{60} = fluid volume absorption of one wheel brake at a pressure corresponding to a braking force of $1.2 B' = 0.6 \cdot G_{Bo}$ and a max. tyre radius.

and

$2r_A$ = outer diameter of brake disc.

(V_{60} in cm^3 , F_{RZ} in cm^2 and r_A in mm)

- 2.2.23. M : braking torque;
 2.2.24. R : dynamic tyre rolling radius (m);
 2.2.25. n : number of brakes.
 2.2.26. D_A : Application force at input side of the control device, at which the overload protector is activated.
 2.2.27. M_A : Braking torque at which the overload protector is activated.

- 2.3. Symbols valid for mechanical-transmission braking systems (see Figure 5 of appendix 1 to this annex);

- 2.3.1. i_{Ho} : reduction ratio between travel of coupling head and travel of lever at output side of control device;
 2.3.2. i_{H1} : reduction ratio between travel of lever at output side of control device and travel of brake lever (gearing down of transmission);
 2.3.3. i_H : reduction ratio between travel of coupling head and travel of brake lever

$$i_H = i_{Ho} \cdot i_{H1}$$

- 2.3.4. i_g : reduction ratio between travel of brake lever and lift (application travel) at brake-shoe centre (see Figure 4 of appendix 1 to this annex);

- 2.3.5. P: force applied to brake control lever;
- 2.3.6. P_0 : brake-retraction force; i.e., in graph $M = f(P)$, the value of the force P at the point of intersection of the extrapolation of this function with the abscissa (see Figure 6 of appendix 1 to this annex);
- 2.3.7. ρ : characteristic of brake as defined by:

$$M = \rho (P - P_0)$$

- 2.4. Symbols valid for hydraulic-transmission braking systems (see Figure 8 of appendix 1 to this annex)

- 2.4.1. i_h : reduction ratio between travel of coupling head and travel of piston in master cylinder;
- 2.4.2. i'_g : reduction ratio between travel of cylinder thrust point and lift (application travel) of brake-shoe centre;
- 2.4.3. F_{RZ} : Surface area of piston of one wheel cylinder for drum brake(s); for disc brake(s), sum of the surface area of the caliper piston(s) on one side of the disc.
- 2.4.4. F_{HZ} : surface area of piston in master cylinder;
- 2.4.5. p: hydraulic pressure in brake cylinder;
- 2.4.6. p_0 : retraction pressure in brake cylinder; i.e., in graph $M = f(p)$, the value of the pressure p at the point of intersection of the extrapolation of this function with the abscissa (see Figure 7 of appendix 1 to this annex);
- 2.4.7. ρ' : characteristic of brake as defined by:

$$M = \rho'(p - p_0).$$

3. GENERAL REQUIREMENTS

- 3.1. The transmission of force from the coupling head to the trailer's brakes must be effected either by rod linkage or by one or more fluids. However, a sheathed cable (Bowden cable) may provide part of the transmission; this part must be as short as possible.
- 3.2. All bolts at joints must be adequately protected. In addition, these joints must be either self-lubricating or readily accessible for lubrication.
- 3.3. Inertia braking devices must be so arranged that in the case when the coupling head travels to its fullest extent, no part of the transmission seizes, undergoes permanent distortion, or breaks. This must be checked by uncoupling the end of the transmission from the brake control levers.
- 3.4. The inertia braking system must allow the trailer to be reversed with the towing vehicle without imposing a sustained drag force exceeding $0.08 g.G_A$. Devices used for this purpose must act automatically and disengage automatically when the trailer moves forward.
- 3.5. Any special device incorporated for the purpose of paragraph 3.4. of this annex shall be such that the parking performance when facing up a

gradient shall not be adversely affected.

3.6. Only inertia braking systems with disc brakes may incorporate overload protectors. They may not be activated at a force of less than $1.2 P$ or a pressure less than $1.2 p$ corresponding to a braking force of $B^* = 0.5 \cdot g \cdot G_{B0}$ (when fitted at the wheel brake) or at a thrust on the coupling less than $1.2 \cdot D^*$ (when fitted at the control device).

4. REQUIREMENTS FOR CONTROL DEVICES

4.1. The sliding members of the control device must be long enough to enable the full travel to be used even when the trailer is coupled.

4.2. The sliding members must be protected by a bellows or some equivalent device. They must either be lubricated or be constructed of self-lubricating materials. The surfaces in frictional contact must be made of a material such that there is neither electrochemical torque nor any mechanical incompatibility liable to cause the sliding members to seize.

4.3. The stress threshold (K_A) of the control device must be not less than $0.02 g G'_A$ and not more than $0.04 g G'_A$.

4.4. The maximum insertion force D_1 may not exceed $0.10 g G'_A$ in trailers with rigid drawbars and $0.067 g G'_A$ in multi-axled trailers with pivoted drawbars.

4.5. The maximum tractive force D_2 must be not less than $0.1 g G'_A$ and not more than $0.5 g G'_A$.

5. TESTS AND MEASUREMENTS TO BE CARRIED OUT ON THE CONTROL DEVICES

5.1. Control devices submitted to the Technical Service conducting the tests must be checked for conformity with the requirements of paragraphs 3 and 4 of this annex.

5.2. The following shall be measured in respect of all types of brakes:

5.2.1. travel s and effective travel s' ;

5.2.2. supplementary force K ;

5.2.3. stress threshold K_A ;

5.2.4. insertion force D_1 ;

5.2.5. tractive force D_2 .

5.3. In the case of mechanical-transmission inertia braking systems, the following should be determined:

5.3.1. the reduction ratio i_{H0} measured at the mid-travel position of the control;

5.3.2. the control-device output force P' as a function of the thrust D on the drawbar.

The supplementary force K and the efficiency are derived from the representative curve obtained from these measurements

$$\eta_{HO} = \frac{1}{i_{HO}} \cdot \frac{P'}{D - K}$$

(see Figure 2 of appendix 1 to this annex)

- 5.4. In the case of hydraulic-transmission inertia braking systems, the following should be determined:
- 5.4.1. the reduction ratio i_h measured at the mid-travel position of the control;
- 5.4.2. the master cylinder output pressure p as a function of the thrust D on the drawbar and of the surface area F_{HZ} of the master-cylinder piston, as specified by the manufacturer. The supplementary force K and the efficiency are derived from the representative curve obtained from these measurements

$$\eta_{HO} = \frac{1}{i_h} \cdot \frac{p \cdot F_{HZ}}{D - K}$$

(see Figure 3 of appendix 1 to this annex);

- 5.4.3. the spare travel of the master cylinder s'' , as referred to in paragraph 2.2.19. of this annex.
- 5.5. In the case of inertia braking system on multi-axled trailers with pivoted drawbar, the loss of travel s_o referred to in paragraph 9.4.1. of this annex should be measured.
6. REQUIREMENTS FOR BRAKES
- 6.1. In addition to the brakes to be checked, the manufacturer must submit to the Technical Service conducting the tests drawings of the brakes showing the type, dimensions and material of the essential components and the make and type of the linings. These drawings must show the surface area F_{RZ} of the brake cylinders in the case of hydraulic brakes. The manufacturer must also specify the maximum braking torque M_{max} he allows, and the mass G_{Bo} referred to in paragraph 2.2.4. of this annex.
- 6.2. The braking torque M_{max} specified by the manufacturer shall be not less than that braking torque corresponding to 1.2 times the force P or 1.2 times the pressure p , required to give a braking force of $B^* = 0.5 \cdot g \cdot G_{Bo}$.
- 6.2.1. In the case when no overload protector is neither fitted nor intended to be fitted within the inertia (overrun) braking system:

The wheel brake must be tested at 1.8 times the force P or at 1.8 times the pressure p , which is required to give a braking force of $B^* = 0.5 \cdot g \cdot G_{Bo}$.
- 6.2.2. In the case when an overload protector is fitted or intended to be fitted within the inertia (overrun) braking system:

The wheel brake must be tested at 1.1 times the force P_{max} or P'_{max} or

at 1.1 times the pressure p_{\max} or p'_{\max} of the overload protector including all tolerances (specified by the manufacturer).

7. TESTS AND MEASUREMENTS TO BE CARRIED OUT ON THE BRAKES
- 7.1. Brakes and components submitted to the Technical Service conducting the tests must be tested for conformity with the requirements of paragraph 6 of this annex.
- 7.2. The following should be determined:
 - 7.2.1. The minimum brake-shoe lift (minimum brake-shoe application travel), $2s_{B^*}$;
 - 7.2.2. The brake-shoe lift (brake-shoe application travel) $2s_B$ (which must be greater than $2s_{B^*}$);
 - 7.2.3. The braking torque M as a function of the force P applied to the control lever in mechanical-transmission systems and of the pressure p in the brake cylinder in hydraulic-transmission systems. The rotational speed of the braking surfaces must correspond to an initial vehicle speed of 60 km/h. The following shall be derived from the curve obtained from these measurements:
 - 7.2.3.1. the retraction force P_0 and the characteristic ρ in the case of mechanically actuated brakes (see Figure 6 of appendix 1 to this annex);
 - 7.2.3.2. the retraction pressure p_0 and the characteristic ρ' in the case of hydraulically actuated brakes (see Figure 7 of appendix 1 to this annex).

8. TEST REPORTS

Applications for the approval of trailers equipped with inertia braking systems shall be accompanied by the test reports relating to the control device and the brakes and the test report on the compatibility of the inertia type control device, the transmission device and the brakes of the trailer, these reports including at least the particulars prescribed in appendices 2, 3, and 4 to this annex.

9. COMPATIBILITY BETWEEN THE CONTROL DEVICE AND THE BRAKES OF A VEHICLE

9.1. A check must be made on the vehicle to verify in the light of the characteristics of the control device (appendix 2), the characteristics of the brakes (appendix 3), and the trailer characteristics referred to in paragraph 4 of appendix 4 to this annex, whether the trailer's inertia braking system meets the prescribed requirements.

9.2. General checks for all types of brakes

9.2.1. Any parts of the transmission not checked at the same time as the control device or the brakes must be checked on the vehicle. The results of the check must be entered in appendix 4 to this annex (e.g., i_{H1} and η_{H1}).

9.2.2. Mass

9.2.2.1. The maximum mass G_A of the trailer must not exceed the maximum mass G'_A for which the control device is authorized.

9.2.2.2. The maximum mass G_A of the trailer must not exceed the maximum mass G_B which can be braked by joint operation of all of the trailer's brakes.

9.2.3. Forces

9.2.3.1. The stress threshold K_A must not be below $0.02 g G_A$ and not above $0.04 g G_A$.

9.2.3.2. The maximum insertion force D_1 may not exceed $0.100 g G_A$ in trailers with rigid drawbar and $0.067 g G_A$ in multi-axled trailers with pivoted drawbar.

9.2.3.3. The maximum tractive force D_2 must be between $0.1 g G_A$ and $0.5 g G_A$.

9.3. Check of braking efficiency

9.3.1. The sum of the braking forces exerted on the circumference of the trailer wheels must not be less than $B^* = 0.50 g G_A$, including a rolling resistance of $0.01 g G_A$: this corresponds to a braking force B of $0.49 g G_A$. In this case, the maximum permissible thrust on the coupling shall be:

$D^* = 0.067 g G_A$ in the case of multi-axled trailers with pivoted drawbar; and

$D^* = 0.100 g G_A$ in the case of trailers with rigid drawbar.

To check whether these conditions are complied with the following inequalities must be applied:

9.3.1.1. In mechanical-transmission inertia braking systems:

$$\left[\frac{B.R}{\rho} + n P_o \right] \frac{1}{(D^* - K) \cdot \eta_H} \leq i_H$$

9.3.1.2. In hydraulic-transmission inertia braking systems:

$$\left[\frac{B.R}{n \cdot \rho'} + P_o \right] \frac{1}{(D^* - K) \cdot \eta_H} \leq \frac{i_h}{F_{HZ}}$$

9.4. Check of control travel

9.4.1. In control devices for multi-axled trailers with pivoted drawbars where the brake rod linkage depends on the position of the towing device, the control travel s must be longer than the effective (useful) control travel s' , the difference being at least equivalent to the loss of travel s_o . The travel loss of s_o must not exceed 10 per cent of the effective travel s' .

9.4.2. The effective (useful) control travel s' shall be determined as follows:

9.4.2.1. if the brake rod linkage is affected by the angular position of the towing device, then:

$$s' = s - s_o ;$$

9.4.2.2. if there is no loss of travel, then:

$$s' = s ;$$

9.4.2.3. in hydraulic braking systems:

$$s' = s - s''.$$

9.4.3. The following inequalities shall be applied to check whether control travel is adequate;

9.4.3.1. In mechanical-transmission inertia braking systems:

$$i_H \leq \frac{s'}{S_{B^*} \cdot i_g}$$

9.4.3.2. in hydraulic-transmission inertia braking systems:

$$\frac{i_h}{F_{HZ}} \leq \frac{s'}{2S_{B^*} \cdot nF_{RZ} \cdot i_g'}$$

9.5. Additional checks

9.5.1. In mechanical-transmission inertia braking systems a check shall be made to verify that the rod linkage by which the forces are

transmitted from the control device to the brakes is correctly fitted.

9.5.2. In hydraulic-transmission inertia braking systems a check shall be made to verify that the travel of the master cylinder is not less than s/i_h . A lower level shall not be permitted.

9.5.3. The general behaviour of the vehicle when braking shall be the subject of a road test carried out at different road speeds with different levels of brake effort and rates of application. Self-excited, undamped oscillations shall not be permitted.

10. GENERAL COMMENTS

The above requirements apply to the most usual embodiments of mechanical-transmission or hydraulic-transmission inertia braking systems where, in particular, all of the trailer's wheels are equipped with the same type of brake and the same type of tyre. For checking less usual embodiments, the above requirements must be adapted to the circumstances of the particular case.

Annex 12 - Appendix 1

Figure 1: SYMBOLS VALID FOR ALL TYPES OF BRAKES
(See paragraph 2.2. of this annex)

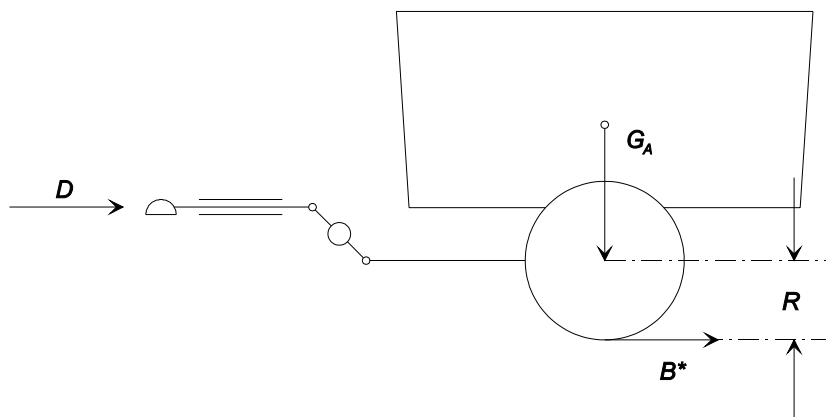
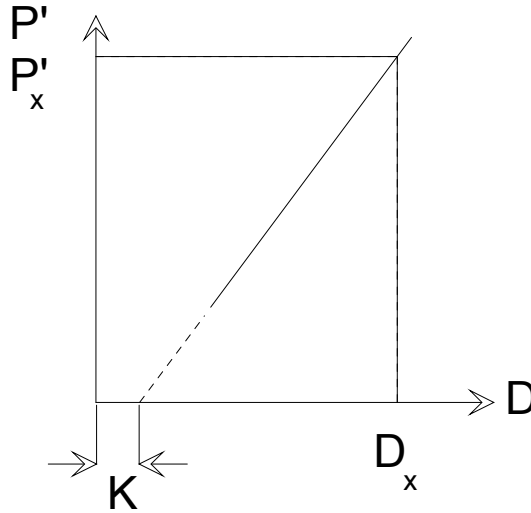
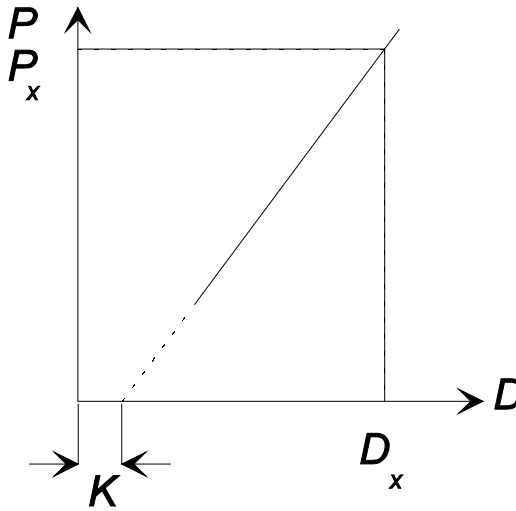

Figure 2: MECHANICAL-TRANSMISSION
 (See paragraphs 2.2.10. and 5.3.2. of this annex)



$$\eta_{H0} = \frac{P'_x}{D_x - K} \cdot \frac{1}{i_{H0}}$$

Figure 3: HYDRAULIC-TRANSMISSION
 (See paragraphs 2.2.10. and 5.4.2. of this annex)



$$\eta_{H0} = \frac{P_x}{D_x - K} \cdot \frac{F_{Hz}}{i_H}$$

Figure 4: BRAKE CHECKS
 (See paragraphs 2.2.22. and 2.3.4. of this annex)

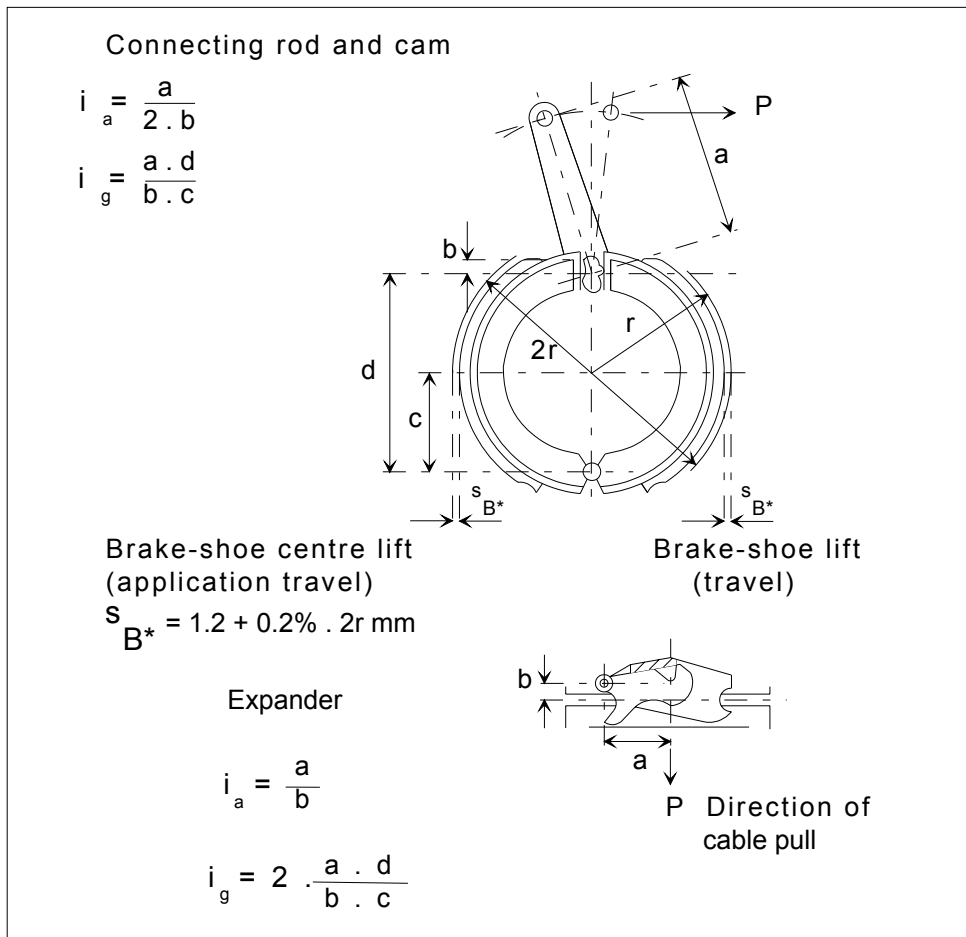
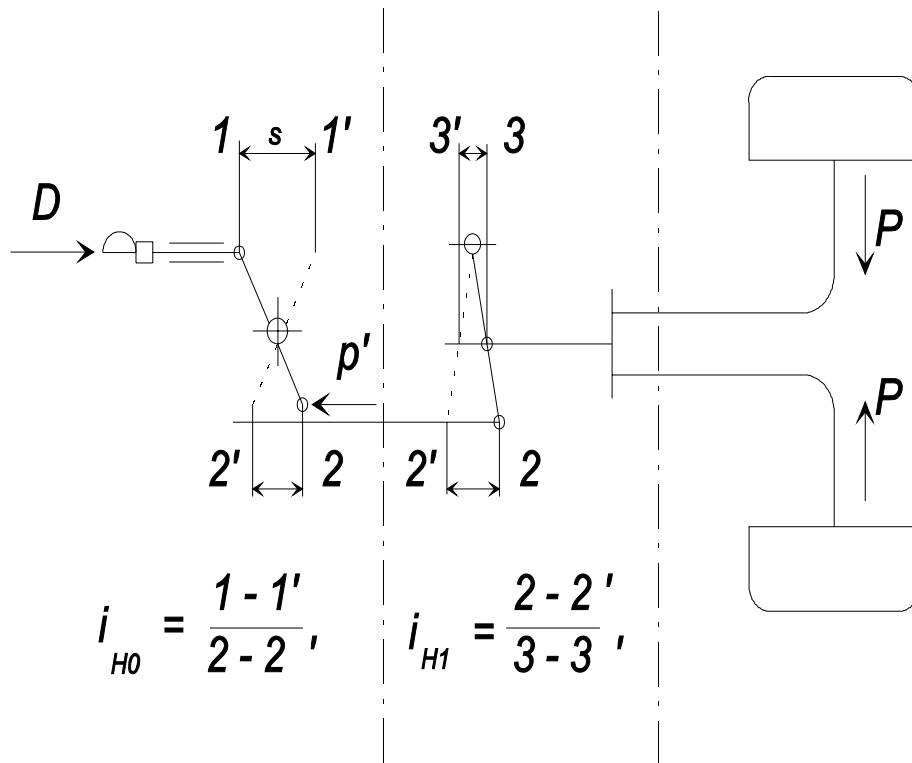
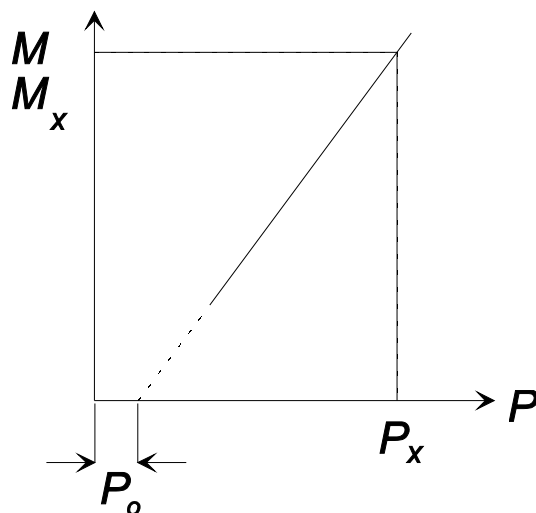

Figure 5: MECHANICAL-TRANSMISSION BRAKING SYSTEM
 (See paragraph 2.3. of this annex)



1.2 Control device 1.3 Transmission 1.4 Brakes

Figure 6: MECHANICAL BRAKE
 (See paragraphs 2.3.6. and 7.2.3.1. of this annex)



$$\rho = \frac{M_x}{P_x - P_0}$$

Figure 7: HYDRAULIC BRAKE
 (See paragraphs 2.4.6. and 7.2.3.2. of this annex)

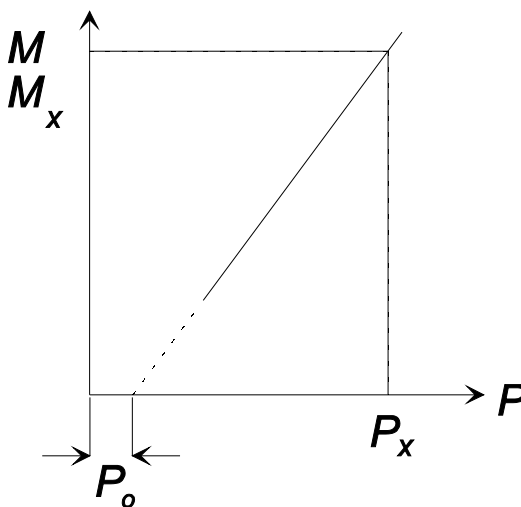

$$\rho' = \frac{M_x}{P_x - P_0}$$

Figure 8: HYDRAULIC TRANSMISSION BRAKING SYSTEM
 (See paragraph 2.4. of this annex)

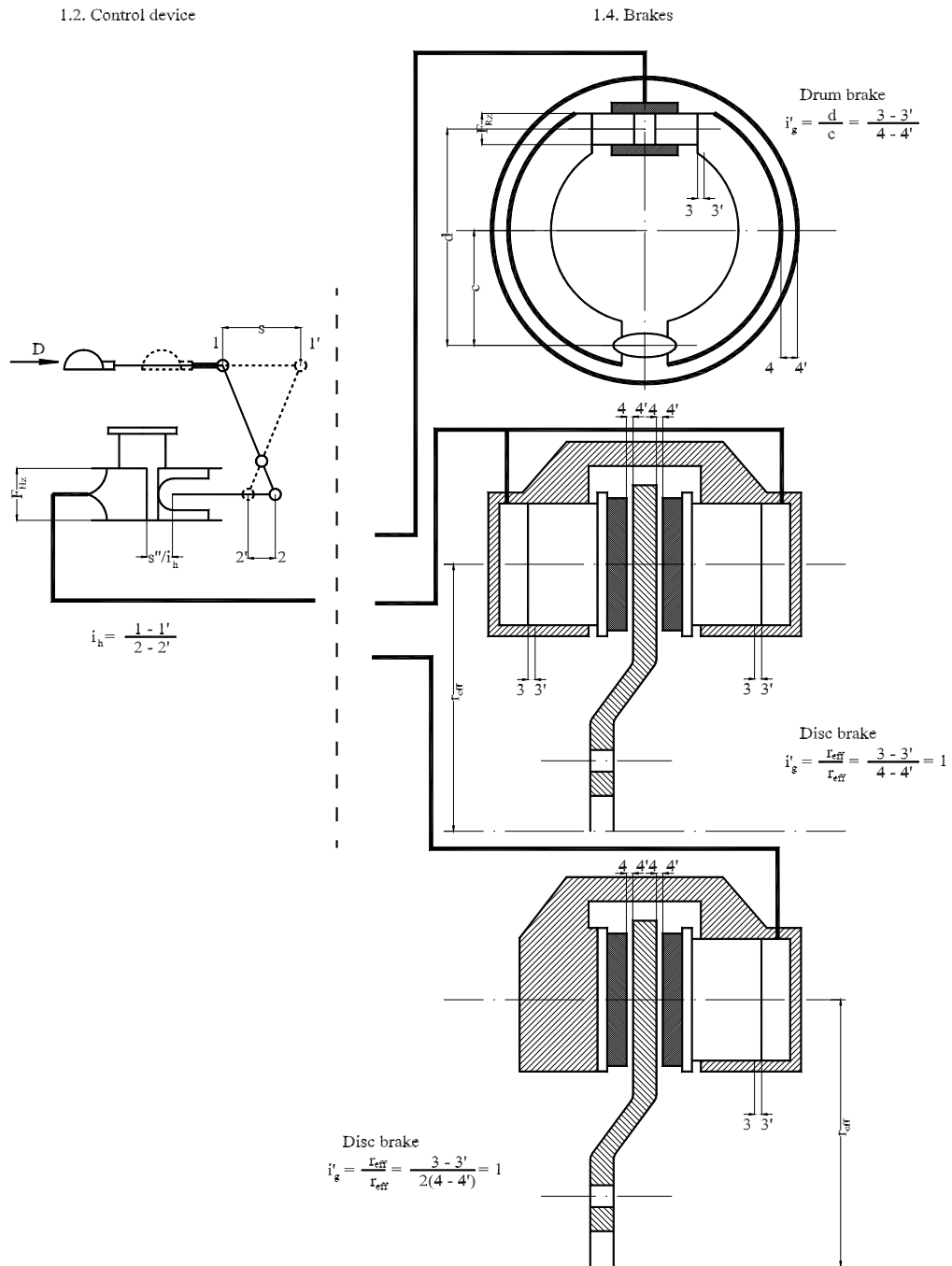

Annex 12 - Appendix 2

TEST REPORT ON INERTIA-BRAKING SYSTEM CONTROL DEVICE

1. Manufacturer
2. Make
3. Type
4. Characteristics of trailers for which control device intended by manufacturer:
 - 4.1. mass $G'_A =$ kg
 - 4.2. permissible static vertical force at towing-device head N
 - 4.3. trailer with rigid drawbar/multi-axled trailer with pivoted drawbar 1/
5. Brief description
 (List of attached plans and dimensioned drawings)
6. Diagram showing principle of control
7. Travel $s =$ mm
8. Reduction ratio of control device:
 - 8.1. with mechanical transmission device 1/
 $i_{Ho} =$ from to 2/
 - 8.2. with hydraulic transmission device 1/
 $i_h =$ from to 2/
 $F_{HZ} =$ cm^2
 travel of master cylinder actuator mm
9. Test results:
 - 9.1. Efficiency
 - with mechanical transmission device 1/ $\eta_H =$
 - with hydraulic transmission device 1/ $\eta_H =$
 - 9.2. Supplementary force $K =$ N
 - 9.3. Maximum compressive force $D_1 =$ N
 - 9.4. Maximum tractive force $D_2 =$ N
 - 9.5. Stress threshold $K_A =$ N
 - 9.6. Loss of travel and spare travel:
 where the position of the drawing device
 has an effect s_o 1/ = mm
 with a hydraulic-transmission device s'' 1/ = mm

- 9.7. Effective (useful) travel of control s' = mm
- 9.8. An overload protector according to paragraph 3.6. of this annex is provided / not provided 1/
- 9.8.1. If the overload protector is fitted before the transmission lever of the control device
- 9.8.1.1. Threshold force of the overload protector
 $D_A =$ N
- 9.8.1.2. where the overload protector is mechanical 1/
max. force P'_{max} which the inertia control device can develop
 $P'_{max}/i_{Ho} =$ N
- 9.8.1.3. where the overload protector is hydraulic 1/
max. hydraulic pressure which the inertia control device can develop
 $p'_{max}/i_h =$ N/cm^2
- 9.8.2. If the overload protector is fitted after the transmission lever of the control device
- 9.8.2.1. Threshold force of the overload protector
where the overload protector is mechanical 1/ $D_A \cdot i_{Ho} =$ N
where the overload protector is hydraulic 1/ $D_A \cdot i_h =$ N
- 9.8.2.2. Where the overload protector is mechanical 1/
max force P'_{max} which the inertia control device can develop
 $P'_{max} =$ N
- 9.8.2.3. Where the overload protector is hydraulic 1/
max hydraulic pressure which the inertia control device can develop
 $P'_{max} =$ N/cm^2

10. Technical Service which carried out the tests
11. The control device described above complies/does not comply 1/ with the requirements of paragraphs 3, 4 and 5 of this annex.
- Date
- Signature

1/ Strike out what does not apply.

2/ State lengths whose ratio was used to determine i_{Ho} or i_h .

Annex 12 - Appendix 3

TEST REPORT ON THE BRAKE

1. Manufacturer
2. Make
3. Type
4. Technically permissible maximum mass per wheel G_{Bo} = kg
5. Braking torque M_{max} = Nm
(as specified by the manufacturer according to paragraph 6.2. of this annex)
- 5.1. Tested braking torque = Nm
(according to paragraphs 6.2.1. and 6.2.2. respectively of this annex)
6. Dynamic tyre rolling radius
 R_{min} = m; R_{max} = m
7. Brief description
(List of plans and dimensioned drawings)
8. Diagram showing principle of brake
9. Test result:

<u>mechanical brake 1/</u>	<u>hydraulic brake 1/</u>
9.1. Reduction ratio $i_g = \underline{2/}$	9.1.A. Reduction ratio $i'_g = \underline{2/}$
9.2. Lift (application travel) $s_B =$ mm	9.2.A. Lift (application travel) $s_B =$ m
9.3. Prescribed lift (prescribed application travel) $s_{B*} =$ mm	9.3.A. Prescribed lift (prescribed application travel) $s_{B*} =$ mm
9.4. Retraction force $P_o =$ N	9.4.A. Retraction pressure $P_o =$ N
9.5. Coefficient (characteristic) $Q =$ m	9.5.A. Coefficient (characteristic) $Q' =$ m
9.6. An overload protector according to paragraph 3.6. of this annex is/is not provided <u>1/</u>	9.6.A. An overload protector according to paragraph 3.6. of this annex is/is not provided <u>1/</u>
9.6.1. Braking torque activating the overload protector $M_A =$ Nm	9.6.1.A. Braking torque activating the overload protector $M_A =$ Nm
9.7. Max. permissible force for M_{max} $P_{max} =$ N	9.7.A. Max. permissible pressure for M_{max} $P_{max} =$ N/cm ²
	9.8.A. Surface area of wheel cylinder $F_{RZ} =$ cm ² $P_{max} =$ N/cm ²

9.9.A. (for disk brakes)
Fluid volume
absorption
 $V_{60} = \dots \text{ cm}^2$

10. Technical Service which carried out the tests
11. The above brake does / does not 1/ conform to the requirements of paragraphs 3 and 6 of the testing conditions for vehicles fitted with inertia braking systems described in this annex.
The brake may / may not 1/ be used for an inertia braking system without an overload protector.

Date:
Signature:

1/ Strike out what does not apply.
2/ State lengths used to determine i_g or i'_g

Annex 12 - Appendix 4

TEST REPORT ON THE COMPATIBILITY OF THE INERTIA BRAKE CONTROL DEVICE,
THE TRANSMISSION AND THE BRAKES ON THE TRAILER

1. Control device
described in the attached test report (see appendix 2 to this annex)
Reduction ratio selected:
 i_{Ho} 1/ = 2/ or i_h 1/ = 2/
(must be within the limits specified in paragraphs 8.1. or 8.2. of
appendix 2 to this annex)
2. Brakes
described in the attached test report (see appendix 3 to this annex)
3. Transmission devices on the trailer
- 3.1. Brief description with diagram showing principle
- 3.2. Reduction ratio and efficiency of the mechanical-transmission device
on the trailer
 i_{H1} 1/ = 2/
 η_{H1} 1/ =
4. Trailer
- 4.1. Manufacturer
- 4.2. Make
- 4.3. Type
- 4.4. Type of drawbar connection: trailer with rigid drawbar/multi-axled
trailer with pivoted drawbar 1/
- 4.5. Number of brakes n =
- 4.6. Technically permissible maximum mass G_A = kg
- 4.7. Dynamic tyre rolling radius R = m

1/ Strike out what does not apply.

2/ State lengths used to determine i_{Ho} , i_h , i_{H1} .

- 4.8. Permissible thrust on coupling
 $D^* = 0.100 \text{ g } G_A \underline{1}/ = \dots \dots \dots \text{ N}$
 or
 $D^* = 0.067 \text{ g } G_A \underline{1}/ = \dots \dots \dots \text{ N}$
- 4.9. Required braking force $B^* = 0.50 \text{ g } G_A = \dots \dots \dots \text{ N}$
- 4.10. Brake force $B = 0.49 \text{ g } G_A = \dots \dots \dots \text{ N}$
5. Compatibility - Test results
- 5.1. Stress threshold $100 \cdot K_A / (\text{g} \cdot G_A) = \dots \dots \dots$
 (must be between 2 and 4)
- 5.2. Maximum compressive force $100 \cdot D_1 / (\text{g} \cdot G_A) = \dots \dots \dots$
 (must not exceed 10 for trailers with rigid drawbar, or 6.7 for
 multi-axled trailers with pivoted drawbar)
- 5.3. Maximum tractive force $100 \cdot D_2 / (\text{g} \cdot G_A) = \dots \dots \dots$
 (must be between 10 and 50)
- 5.4. Technically permissible maximum mass for inertia control device
 $G'_A = \dots \dots \dots \text{ kg}$
 (must not be less than G_A)
- 5.5. Technically permissible maximum mass for all of trailer's brakes
 $G_B = n \cdot G_{Bo} = \dots \dots \dots \text{ kg}$
 (must not be less than G_A)
- 5.6. Maximum braking torque of the brakes
 $n \cdot M_{\max} / (B \cdot R) = \dots \dots \dots$
 (must be equal or greater than 1.2)
- 5.6.1. An overload protector within the meaning of paragraph 3.6. of this
 annex is / is not 1/ fitted on the inertia control device / on the
 brakes 1/
- 5.6.1.1. where the overload protector is mechanical on the inertia control
 device 1/
 $n \cdot P_{\max} / (i_{H1} \cdot \eta_{H1} \cdot P'_{\max}) = \dots \dots \dots$
 (must be equal or greater than 1.0)
- 5.6.1.2. where the overload protector is hydraulic on the inertia control
 device 1/
 $P_{\max} / P'_{\max} = \dots \dots \dots$
 (must be equal or greater than 1.0)
- 5.6.1.3. if the overload protector is on the inertia control device:
 threshold force $D_A / D^* = \dots \dots \dots$
 (must be equal or greater than 1.2)
- 5.6.1.4. if the overload protector is fitted on the brake:
 threshold torque $n \cdot M_A / (B \cdot R) = \dots \dots \dots$
 (must be equal or greater than 1.2)"
- 5.7. Inertia braking system with mechanical transmission device 1/
- 5.7.1. $i_H = i_{Ho} \cdot i_{H1} = \dots \dots \dots$

1/ Strike out what does not apply.

5.7.2. $\eta_H = \eta_{Ho} \cdot \eta_{H1} = \dots$

5.7.3.

$$\left[\frac{B \cdot R}{Q} + n \cdot P_o \right] \cdot \frac{1}{(D^* - K) \cdot \eta_H} = \dots$$

(must not be greater than i_H)

5.7.4.

$$\frac{s'}{s_{B^*} \cdot i_g} = \dots$$

(must not be less than i_H)

5.8. Inertia braking system with hydraulic transmission device 1/

5.8.1. $i_h/F_{Hz} = \dots$

5.8.2.

$$\left[\frac{B \cdot R}{n \cdot \rho'} + p_o \right] \cdot \frac{1}{(D^* - K) \cdot \eta_H} = \dots$$

(must not be greater than i_h/F_{Hz})

5.8.3.

$$\frac{s'}{2s_{B^*} \cdot n \cdot F_{RZ} \cdot i'_g} = \dots\dots\dots$$

(must not be less than i_h/F_{HZ})

5.8.4. $s/i_h = \dots\dots\dots$
(must not be greater than travel of master cylinder actuator as specified in paragraph 8.2. of appendix 2 to this annex)

6. Technical Service which carried out the tests $\dots\dots\dots$

7. The inertia braking system described above complies/does not comply 1/ with the requirements of paragraphs 3 to 9 of this annex.

Date $\dots\dots\dots$
Signature $\dots\dots\dots$

1/ Strike out what does not apply.

Annex 13

TEST REQUIREMENTS FOR VEHICLES FITTED WITH
ANTI-LOCK SYSTEMS

1. GENERAL
 - 1.1. This annex defines the required braking performance for road vehicles fitted with anti-lock systems. In addition, power-driven vehicles which are authorized to tow a trailer, and trailers equipped with compressed-air braking systems, shall, when the vehicles are laden, meet the requirements for compatibility set out in annex 10 to this Regulation.
 - 1.2. The anti-lock systems known at present comprise a sensor or sensors, a controller or controllers and a modulator or modulators. Any device of a different design which may be introduced in the future, or where an anti-lock braking function is integrated into another system, shall be deemed to be an anti-lock braking system within the meaning of this annex and annex 10 to this Regulation, if it provides performance equal to that prescribed by this annex.
2. DEFINITIONS
 - 2.1. An "anti-lock system" is a part of a service braking system which automatically controls the degree of slip, in the direction of rotation of the wheel(s), on one or more wheels of the vehicle during braking.
 - 2.2. "Sensor" means a component designed to identify and transmit to the controller the conditions of rotation of the wheel(s) or the dynamic conditions of the vehicle.
 - 2.3. "Controller" means a component designed to evaluate the data transmitted by the sensor(s) and to transmit a signal to the modulator.
 - 2.4. "Modulator" means a component designed to vary the braking force(s) in accordance with the signal received from the controller.
 - 2.5. "Directly controlled wheel" means a wheel whose braking force is modulated according to data provided at least by its own sensor. 1/
 - 2.6. "Indirectly controlled wheel" means a wheel whose braking force is modulated according to data provided by the sensor(s) of other wheel(s). 1/
 - 2.7. "Full cycling" means that the anti-lock system is repeatedly modulating the brake force to prevent the directly controlled wheels from locking. Brake applications where modulation only occurs once during the stop shall not be considered to meet this definition.

In the case of trailers with pneumatic braking systems, full cycling of the anti-lock braking system is only assured when the pressure available at any brake actuator of a directly controlled wheel is more than 1 bar above the maximum cycling pressure

1/ Anti-lock systems with select-high control are deemed to include both directly and indirectly controlled wheels; in systems with select-low control, all sensed wheels are deemed to be directly controlled wheels.

throughout a given test. The supply pressure available may not be increased above 8 bar.

3. TYPES OF ANTI-LOCK SYSTEMS

3.1. A power-driven vehicle is deemed to be equipped with an anti-lock system within the meaning of paragraph 1 of annex 10 to this Regulation, if one of the following systems is fitted:

3.1.1. Category 1 anti-lock system

A vehicle equipped with a category 1 anti-lock system shall meet all the relevant requirements of this annex.

3.1.2. Category 2 anti-lock system

A vehicle equipped with a category 2 anti-lock system shall meet all the relevant requirements of this annex, except those of paragraph 5.3.5.

3.1.3. Category 3 anti-lock system

A vehicle equipped with a category 3 anti-lock system shall meet all the relevant requirements of this annex, except those of paragraphs 5.3.4. and 5.3.5. On such vehicles, any individual axle (or bogie) which does not include at least one directly controlled wheel must fulfil the conditions of adhesion utilization and the wheel-locking sequence of annex 10 to this Regulation, with regard to the braking rate and the load respectively. These requirements may be checked on high- and low-adhesion road surfaces (about 0.8 and 0.3 maximum) by modulating the service braking control force.

3.2. A trailer is deemed to be equipped with an anti-lock system within the meaning of paragraph 1 of annex 10 to this Regulation when at least two wheels on opposite sides of the vehicle are directly controlled and all remaining wheels are either directly or indirectly controlled by the anti-lock system. In the case of full trailers, at least two wheels on one front axle and two wheels on one rear axle are directly controlled with each of these axles having at least one independent modulator and all remaining wheels are either directly or indirectly controlled. In addition, the anti-lock equipped trailer shall meet one of the following conditions:

3.2.1. Category A anti-lock system

A trailer equipped with a category A anti-lock system shall meet all the relevant requirements of this annex.

3.2.2. Category B anti-lock system

A trailer equipped with a category B anti-lock system shall meet all the relevant requirements of this annex, except paragraph 6.3.2.

4. GENERAL REQUIREMENTS

4.1. Any electrical failure or sensor anomaly that affects the system with respect to the functional and performance requirements in this annex, including those in the supply of electricity, the external

wiring to the controller(s), the controller(s) 2/ and the modulator(s) shall be signalled to the driver by a specific optical warning signal. The yellow warning signal specified in paragraph 5.2.1.29.1.2. shall be used for this purpose.

- 4.1.1. The warning signal shall light up when the anti-lock system is energized and with the vehicle stationary and it shall be verified that none of the above-mentioned defects are present before extinguishing the signal.
- 4.1.2. The static sensor check may verify that a sensor was not functioning the last time that the vehicle was at a speed greater than 10 km/h. 3/ Also during this verification phase, the electrically controlled pneumatic modulator valve(s) shall cycle at least once.
- 4.2. Power-driven vehicles equipped with an anti-lock system and authorized to tow a trailer equipped with such a system, with the exception of vehicles of categories M₁ and N₁, shall be fitted with a separate optical warning signal for the anti-lock system of the trailer, meeting the requirements of paragraph 4.1. of this annex. The separate yellow warning signals specified in paragraph 5.2.1.29.2. shall be used for this purpose, activated via pin 5 of the electrical connector conforming to ISO/DIS 7638:1996 4/.
- 4.3. In the event of a failure in the anti-lock system, the residual braking performance shall be that prescribed for the vehicle in question in the event of a failure of part of the transmission of the service braking system (see paragraph 5.2.1.4. of this Regulation). This requirement shall not be construed as a departure from the requirements concerning secondary braking. In the case of trailers the residual braking performance in the event of a defect in the anti-lock system according to paragraph 4.1. shall be at least 80 per cent of the prescribed laden performance for the service braking system of the relevant trailer.
- 4.4. The operation of the anti-lock system shall not be adversely affected by magnetic or electrical fields. This shall be demonstrated by compliance with Regulation No. 10, 02 series of amendments.
- 4.5. A manual device may not be provided to disconnect or change the

2/ Until uniform test procedures have been agreed, the manufacturer shall provide the Technical Service with an analysis of potential failures within the controller(s) and their effects. This information shall be subject to discussion and agreement between the Technical Service and the vehicle manufacturer.

3/ The warning signal may light up again while the vehicle is stationary, provided that it is extinguished before the vehicle speed reaches 10 km/h when no defect is present.

4/ The ISO/DIS 7638:1996 connector may be used for 5 pin or 7 pin applications, as appropriate.

control mode 1/ of the anti-lock system, except on off-road power-driven vehicles of categories N₂ and N₃ as defined in annex 7 to the Consolidated Resolution on the Construction of Vehicles (R.E.3); where a device is fitted to N₂ or N₃ category vehicles, the following conditions must be met:

- 4.5.1. the power-driven vehicle with the anti-lock system disconnected or the control mode changed by the device referred to in paragraph 4.5. above must satisfy all the relevant requirements in annex 10 to this Regulation;
- 4.5.2. an optical warning signal shall inform the driver that the anti-lock system has been disconnected or the control mode changed; the yellow anti-lock failure warning signal specified in paragraph 5.2.1.29.1.2. may be used for this purpose.
- 4.5.3. the anti-lock system must automatically be reconnected/returned to on-road mode when the ignition (start) device is again set to the "ON" (run) position;
- 4.5.4. the vehicle user's handbook provided by the manufacturer should warn the driver of the consequences of manual disconnection or mode change of the anti-lock system;
- 4.5.5. the device referred to in paragraph 4.5. above may, in conjunction with the towing vehicle, disconnect/change the control mode of the anti-lock system of the trailer. A separate device for the trailer alone is not permitted.

5. SPECIAL PROVISIONS CONCERNING POWER-DRIVEN VEHICLES

5.1. Energy consumption

Power-driven vehicles equipped with anti-lock systems must maintain their performance when the service braking control device is fully applied for long periods. Compliance with this requirement shall be verified by means of the following tests:

- 5.1.1. Test procedure
 - 5.1.1.1. The initial energy level in the energy storage device(s) shall be that specified by the manufacturer. This level shall be at least such as to ensure the efficiency prescribed for service braking when the vehicle is laden. The energy storage device(s) for pneumatic auxiliary equipment must be isolated.
 - 5.1.1.2. From an initial speed of not less than 50 km/h, on a surface with a coefficient of adhesion of 0.3 6/ or less, the brakes of the laden vehicle shall be fully applied for a time t, during which time the energy consumed by the indirectly controlled wheels shall be taken

1/ It is understood that devices changing the control mode of the anti-lock system are not subject to paragraph 4.5. of this annex if in the changed control mode condition all requirements for the category of anti-lock systems, with which the vehicle is equipped, are fulfilled. However, in this case, paragraphs 4.5.2., 4.5.3. and 4.5.4. of this annex shall be met.

6/ Until such test surfaces become generally available, tyres at the limit of wear, and higher values up to 0.4 may be used at the discretion of the Technical Service. The actual value obtained and the type of tyres and surface shall be recorded.

into consideration and all directly controlled wheels must remain under control of the anti-lock system.

- 5.1.1.3. The vehicle's engine shall then be stopped or the supply to the energy transmission storage device(s) cut off.
- 5.1.1.4. The service braking control device shall then be fully actuated four times in succession with the vehicle stationary.
- 5.1.1.5. When the control device is applied for the fifth time, it must be possible to brake the vehicle with at least the performance prescribed for secondary braking of the laden vehicle.
- 5.1.1.6. During the tests, in the case of a power-driven vehicle authorized to draw a trailer equipped with a compressed-air braking system, the supply line shall be stopped and an energy storage device of 0.5 litre capacity shall be connected to the pneumatic control line - if fitted - (in accordance with paragraph 1.2.2.3. of Part A of annex 7 to this Regulation). When the brakes are applied for the fifth time, as provided in paragraph 5.1.1.5. above, the energy level supplied to the pneumatic control line shall not be below half the level obtained at a full application starting with the initial energy level.

5.1.2. Additional requirements

- 5.1.2.1. The coefficient of adhesion of the road surface shall be measured with the vehicle under test, by the method described in paragraph 1.1. of appendix 2 to this annex.
- 5.1.2.2. The braking test shall be conducted with the engine disconnected and idling, and with the vehicle laden.
- 5.1.2.3. The braking time t shall be determined by the formula:

$$t = \frac{v_{\max}}{7} \quad (\text{but not less than 15 seconds})$$

where

t is expressed in seconds and v_{\max} represents the maximum design speed of the vehicle expressed in km/h, with an upper limit of 160 km/h.

- 5.1.2.4. If the time t cannot be completed in a single braking phase, further phases may be used, up to a maximum of four in all.
- 5.1.2.5. If the test is conducted in several phases, no fresh energy shall be supplied between the phases of the test.

From the second phase, the energy consumption corresponding to the initial brake application may be taken into account, by subtracting one full brake application from the four full applications prescribed in paragraph 5.1.1.4. (and 5.1.1.5., 5.1.1.6. and 5.1.2.6.) of this annex for each of the second, third and fourth phases used in the test prescribed in paragraph 5.1.1. of this annex as applicable.

- 5.1.2.6. The performance prescribed in paragraph 5.1.1.5. of this annex shall be deemed to be satisfied if, at the end of the fourth application, with the vehicle stationary, the energy level in the storage device(s) is at or above that required for secondary

braking with the laden vehicle.

5.2. Utilization of adhesion

- 5.2.1. The utilization of adhesion by the anti-lock system takes into account the actual increase in braking distance beyond the theoretical minimum. The anti-lock system shall be deemed to be satisfactory when the condition $\epsilon \geq 0.75$ is satisfied, where ϵ represents the adhesion utilized, as defined in paragraph 1.2. of appendix 2 to this annex.
- 5.2.2. The adhesion utilization ϵ shall be measured on road surfaces with a coefficient of adhesion of 0.3 6/ or less, and of about 0.8 (dry road), with an initial speed of 50 km/h. To eliminate the effects of differential brake temperatures it is recommended that z_{AL} be determined prior to the determination of k .
- 5.2.3. The test procedure to determine the coefficient of adhesion (k) and the formulae for calculation of the adhesion utilization (ϵ) shall be those laid down in appendix 2 to this annex.
- 5.2.4. The utilization of adhesion by the anti-lock system shall be checked on complete vehicles equipped with anti-lock systems of categories 1 or 2. In the case of vehicles equipped with category 3 anti-lock systems, only the axle(s) with at least one directly controlled wheel must satisfy this requirement.
- 5.2.5. The condition $\epsilon \geq 0.75$ shall be checked with the vehicle laden and unladen.

The laden test on the high adhesion surface may be omitted if the prescribed force on the control device does not achieve full cycling of the anti-lock system.

For the unladen test, the control force may be increased up to 100 daN if no cycling is achieved with its full force value 7/. If 100 daN is insufficient to make the system cycle, then this test may be omitted. For air braking systems the air pressure may not be increased above the cut-out pressure for the purpose of this test.

5.3. Additional checks

The following additional checks shall be carried out, engine disconnected, with the vehicle laden and unladen:

- 5.3.1. The wheels directly controlled by an anti-lock system must not lock

6/ Until such test surfaces become generally available, tyres at the limit of wear, and higher values up to 0.4 may be used at the discretion of the Technical Service. The actual value obtained and the type of tyres and surface shall be recorded.

7/ "Full force" means the maximum force laid down in annex 4 to this Regulation for the category of vehicle; a higher force may be used if required to activate the anti-lock system.

when the full force 7/ is suddenly applied on the control device, on the road surfaces specified in paragraph 5.2.2. of this annex, at an initial speed of 40 km/h and at a high initial speed as indicated on the table below: 8/ 9/

	Vehicle category	Maximum test speed
High-adhesion surface	All categories except N ₂ , N ₃ laden	0.8 v _{max} ≤ 120 km/h
	N ₂ , N ₃ laden	0.8 v _{max} ≤ 80 km/h
Low-adhesion surface	M ₁ , N ₁	0.8 v _{max} ≤ 120 km/h
	M ₂ , M ₃ , N ₂ except tractors for semi-trailers	0.8 v _{max} ≤ 80 km/h
	N ₃ and N ₂ tractors for semi-trailers	0.8 v _{max} ≤ 70 km/h

- 5.3.2. When an axle passes from a high-adhesion surface (k_H) to a low-adhesion surface (k_L) where k_H ≥ 0.5 and k_H/k_L ≥ 2, 10/ with the full force 7/ applied on the control device, the directly controlled wheels must not lock. The running speed and the instant of applying the brakes shall be so calculated that, with the anti-lock system fully cycling on the high-adhesion surface, the passage from one surface to the other is made at high and at low speed, under the conditions laid down in paragraph 5.3.1. of this annex 9/.
- 5.3.3. When a vehicle passes from a low-adhesion surface (k_L) to a high-adhesion surface (k_H) where k_H ≥ 0.5 and k_H/k_L ≥ 2, 10/ with the full force 7/ applied on the control device, the deceleration of the vehicle must rise to the appropriate high value within a

7/ "Full force" means the maximum force laid down in annex 4 to this Regulation for the category of vehicle; a higher force may be used if required to activate the anti-lock system.

8/ The provisions of this paragraph apply as of 13 March 1992 (Decision of the Working Party on the Construction of Vehicles, TRANS/SC1/WP29/341, para. 23).

9/ The purpose of these tests is to check that the wheels do not lock and that the vehicle remains stable; it is not necessary, therefore, to make complete stops and bring the vehicle to a halt on the low-adhesion surface.

10/ k_H is the high-adhesion surface coefficient.
k_L is the low-adhesion surface coefficient.
k_H and k_L are measured as laid down in appendix 2 to this annex.

9/ The purpose of these tests is to check that the wheels do not lock and that the vehicle remains stable; it is not necessary, therefore, to make complete stops and bring the vehicle to a halt on the low-adhesion surface.

reasonable time and the vehicle must not deviate from its initial course. The running speed and the instant of applying the brakes shall be so calculated that, with the anti-lock system fully cycling on the low-adhesion surface, the passage from one surface to the other occurs at approximately 50 km/h.

- 5.3.4. In the case of vehicles equipped with anti-lock systems of categories 1 or 2, when the right and left wheels of the vehicle are situated on surfaces with differing coefficients of adhesion (k_H and k_L), where $k_H \geq 0.5$ and $k_H/k_L \geq 2$, 10/ the directly controlled wheels must not lock when the full force 7/ is suddenly applied on the control device at a speed of 50 km/h.
- 5.3.5. Furthermore, laden vehicles equipped with anti-lock systems of category 1 shall, under the conditions of paragraph 5.3.4. of this annex satisfy the prescribed braking rate in appendix 3 to this annex.
- 5.3.6. However, in the tests provided in paragraphs 5.3.1., 5.3.2., 5.3.3., 5.3.4. and 5.3.5 of this annex, brief periods of wheel-locking shall be allowed. Furthermore, wheel-locking is permitted when the vehicle speed is less than 15 km/h; likewise, locking of indirectly controlled wheels is permitted at any speed, but stability and steerability must not be affected.
- 5.3.7. During the tests provided in paragraphs 5.3.4. and 5.3.5. of this annex, steering correction is permitted, if the angular rotation of the steering control is within 120° during the initial two seconds, and not more than 240° in all. Furthermore, at the beginning of these tests the longitudinal median plane of the vehicle must pass over the boundary between the high- and low-adhesion surfaces and during these tests no part of the (outer) tyres must cross this boundary.

6. SPECIAL PROVISIONS CONCERNING TRAILERS

6.1. Energy consumption

Trailers equipped with anti-lock systems shall be so designed that, even after the service braking control device has been fully applied for some time, the vehicle retains sufficient energy to bring it to a halt within a reasonable distance.

- 6.1.1. Compliance with the above requirement shall be checked by the procedure specified below, with the vehicle unladen, on a straight and level road with a surface having a good coefficient of

10/ k_H is the high-adhesion surface coefficient.
 k_L is the low-adhesion surface coefficient.
 k_H and k_L are measured as laid down in appendix 2 to this annex.

7/ "Full force" means the maximum force laid down in annex 4 to this Regulation for the category of vehicle; a higher force may be used if required to activate the anti-lock system.

adhesion 11/ and with the brakes adjusted as closely as possible and with the proportioning/load-sensing valve (if fitted) held in the "laden" position throughout the test.

- 6.1.2. In the case of compressed-air braking systems, the initial energy level in the energy transmission storage device(s) shall be equivalent to a pressure of 8.0 bar at the coupling head of the trailer's supply line.
- 6.1.3. With an initial vehicle speed of at least 30 km/h the brakes shall be fully applied for a time $t = 15$ s, during which all wheels must remain under control of the anti-lock system. During this test, the supply to the energy transmission storage device(s) shall be cut off.

If the time $t = 15$ s cannot be completed in a single braking phase, further phases may be used. During these phases no fresh energy shall be supplied to the energy transmission storage device(s) and, as from the second phase, the additional energy consumption for filling the actuators is to be taken into account, e.g. by the following test procedure.

The pressure in the reservoir(s) when starting the first phase is to be that stated in paragraph 6.1.2. of this annex. At the beginning of the following phase(s) the pressure in the reservoir(s) after application of the brakes must be not less than the pressure in the reservoir(s) at the end of the preceding phase.

At the subsequent phase(s), the only time to be taken into account is from the point at which the pressure in the reservoir(s) is equal to that at the end of the preceding phase.

- 6.1.4. At the end of the braking, with the vehicle stationary, the service braking control device shall be fully actuated four times. During the fifth application, the pressure in the operating circuit must be sufficient to provide a total braking force at the periphery of the wheels equal to not less than 22.5 per cent of the maximum stationary wheel load and without causing an automatic application of any braking system not being under the control of the anti-lock system.

6.2. Utilisation of adhesion

- 6.2.1. Braking systems equipped with an anti-lock system shall be deemed acceptable when the condition $\epsilon \geq 0.75$ is satisfied, where ϵ represents the adhesion utilized, as defined in paragraph 2 of appendix 2 to this annex. This condition shall be verified with the vehicle unladen, on a straight and level road with a surface

11/ If the coefficient of adhesion of the test track is too high, preventing the anti-lock braking system from full cycling, then the test may be carried out on a surface with a lower coefficient of adhesion.

having a good coefficient of adhesion. 1/ 2/

6.2.2. To eliminate the effects of differential brake temperatures, it is recommended to determine z_{RAL} prior to the determination of k_R .

6.3. Additional checks

6.3.1. At speeds exceeding 15 km/h, the wheels directly controlled by an anti-lock system must not lock when the full force 7/ is suddenly applied on the control device of the towing vehicle. This shall be checked, under the conditions prescribed in paragraph 6.2. of this annex, at initial speeds of 40 km/h and 80 km/h.

6.3.2. The provisions of this paragraph shall only apply to trailers equipped with an anti-lock system of category A. When the right and left wheels are situated on surfaces which produce differing maximum braking rates (z_{RALH} and z_{RALL}), where

$$\frac{z_{RALH}}{\varepsilon_H} \geq 0.5 \quad \text{and} \quad \frac{z_{RALH}}{z_{RALL}} \geq 2$$

the directly controlled wheels must not lock when the full force 8/ is suddenly applied on the control device of the towing vehicle at a speed of 50 km/h. The ratio z_{RALH}/z_{RALL} may be ascertained by the procedure in paragraph 2 of appendix 2 of this annex or by calculating the ratio z_{RALH}/z_{RALL} . Under this condition the unladen vehicle shall satisfy the prescribed braking rate in appendix 3 to this annex. 12/

6.3.3. At vehicle speeds ≥ 15 km/h the directly controlled wheels are permitted to lock for brief periods, but at speeds < 15 km/h any locking is permissible. Indirectly controlled wheels are permitted to lock at any speed but in all cases stability must not be affected.

1/ If the coefficient of adhesion of the test track is too high, preventing the anti-lock braking system from full cycling, then the test may be carried out on a surface with a lower coefficient of adhesion.

2/ In the case of trailers equipped with a brake load sensing device, the pressure setting of the device may be increased to ensure full cycling.

7/ "Full force" means a maximum force laid down in annex 4 to this Regulation for the category of vehicle; a higher force may be used if required to activate the anti-lock system.

8/ "Full force" means a maximum force laid down in annex 4 to this Regulation for the category of vehicle; a higher force may be used if required to activate the anti-lock system.

12/ In the case of trailers equipped with a brake load sensing device, the pressure setting of the device may be increased to ensure full cycling.

E/ECE/324
E/ECE/TRANS/505 } Rev.1/Add.12/Rev.4
Regulation No. 13
page 157
Annex 13

Annex 13 - Appendix 1

SYMBOLS AND DEFINITIONS

TABLE: SYMBOLS AND DEFINITIONS	
SYMBOL	NOTES
E	wheelbase
E_R	distance between king-pin and centre of axle or axles of semi-trailer (or distance between drawbar coupling and centre of axle or axles of centre-axle trailer)
ϵ	the adhesion utilized of the vehicle: quotient of the maximum braking rate with the anti-lock system operative (z_{AL}) and the coefficient of adhesion (k)
ϵ_i	the ϵ -value measured on axle i (in the case of a power-driven vehicle with a category 3 anti-lock system)
ϵ_H	the ϵ -value on the high-adhesion surface
ϵ_L	the ϵ -value on the low-adhesion surface
F	force [N]
F_{bR}	braking force of the trailer with the anti-lock system inoperative
F_{bRmax}	maximum value of F_{bR}
F_{bRmaxi}	value of F_{bRmax} with only axle i of the trailer braked
F_{bRAL}	braking force of the trailer with the anti-lock system operative
F_{Cnd}	total normal reaction of road surface on the unbraked and non-driven axles of the vehicle combination under static conditions
F_{Cd}	total normal reaction of road surface on the unbraked and driven axles of the vehicle combination under static conditions
F_{dyn}	normal reaction of road surface under dynamic conditions with the anti-lock system operative
F_{idyn}	F_{dyn} on axle i in case of power-driven vehicles or full trailers
F_i	normal reaction of road surface on axle i under static conditions
F_M	total normal static reaction of road surface on all wheels of power-driven (towing) vehicle

TABLE: SYMBOLS AND DEFINITIONS	
SYMBOL	NOTES
$F_{Mnd} \underline{1}/$	total normal static reaction of road surface on the unbraked and non-driven axles of the power-driven vehicle
$F_{Md} \underline{1}/$	total normal static reaction of road surface on the unbraked and driven axles of the power-driven vehicle
F_R	total normal static reaction of road surface on all wheels of trailer
F_{Rdyn}	total normal dynamic reaction of road surface on the axle(s) of semi-trailer or centre-axle trailer
$F_{VM} \underline{1}/$	$0.01 F_{Mnd} + 0.015 F_{Md}$
g	acceleration due to gravity (9.81 m/s^2)
h	height of centre of gravity specified by the manufacturer and agreed by the Technical Service conducting the approval test
h_n	height of drawbar (hinge point on trailer)
h_x	height of fifth wheel coupling (king pin)
h_p	height of centre of gravity of the trailer
k	coefficient of adhesion between tyre and road
k_f	k-factor of one front axle
k_H	k-value determined on the high-adhesion surface
k_i	k-value determined on axle i for a vehicle with a category 3 anti-lock system
k_L	k-value determined on the low-adhesion surface
k_{lock}	value of adhesion for 100 % slip
k_M	k-factor of the power-driven vehicle
k_{peak}	maximum value of the curve "adhesion versus slip"
k_r	k-factor of one rear axle
k_R	k-factor of the trailer
P	mass of individual vehicle [kg]
TABLE: SYMBOLS AND DEFINITIONS	
SYMBOL	NOTES
R	ratio of k_{peak} to k_{lock}
t	time interval [s]
t_m	mean value of t

$\underline{1}/$ F_{Mnd} and F_{Md} in case of two-axled power-driven vehicles: these symbols may be simplified to corresponding F_i -symbols.

t_{min}	minimum value of t
z	braking rate
z_{AL}	braking rate z of the vehicle with the anti-lock system operative
z_c	braking rate z of the vehicle combination, with the trailer only braked and the anti-lock system inoperative
z_{CAL}	braking rate z of the vehicle combination, with the trailer only braked and the anti-lock system operative
z_{Cmax}	maximum value of z_c
z_{Cmaxi}	maximum value of z_c with only axle i of the trailer braked
z_m	mean braking rate
z_{max}	maximum value of z
z_{MAIS}	z_{AL} of the power-driven vehicle on a "split surface"
z_R	braking rate z of the trailer with the anti-lock system inoperative
z_{RAL}	z_{AL} of the trailer obtained by braking all the axles, the towing vehicle unbraked and its engine disengaged
z_{RALH}	z_{RAL} on the surface with the high coefficient of adhesion
z_{RALL}	z_{RAL} on the surface with the low coefficient of adhesion
z_{RAIS}	z_{RAL} on the split-surface
z_{RH}	z_R on the surface with the high coefficient of adhesion
z_{RL}	z_R on the surface with the low coefficient of adhesion
z_{RHmax}	maximum value of z_{RH}
z_{RLmax}	maximum value of z_{RL}
z_{Rmax}	maximum value of z_R

Annex 13 - Appendix 2

UTILIZATION OF ADHESION

1. METHOD OF MEASUREMENT FOR POWER-DRIVEN VEHICLES

1.1. Determination of the coefficient of adhesion (k)

1.1.1. The coefficient of adhesion (k) shall be determined as the quotient of the maximum braking forces without locking the wheels and the corresponding dynamic load on the axle being braked.

1.1.2. The brakes shall be applied on only one axle of the vehicle under test, at an initial speed of 50 km/h. The braking forces shall be distributed between the wheels of the axle to reach maximum performance. The anti-lock system shall be disconnected, or inoperative, between 40 km/h and 20 km/h.

1.1.3. A number of tests at increments of line pressure shall be carried out to determine the maximum braking rate of the vehicle (z_{\max}). During each test, a constant input force shall be maintained and the braking rate will be determined by reference to the time taken (t) for the speed to reduce from 40 km/h to 20 km/h using the formula:

$$z = \frac{0.566}{t}$$

z_{\max} is the maximum value of z; t is in seconds.

1.1.3.1. Wheel lock may occur below 20 km/h.

1.1.3.2. Starting from the minimum measured value of t, called t_{\min} , then select three values of t comprised within t_{\min} and $1.05 t_{\min}$ and calculate their arithmetical mean value t_m , then calculate

$$z_m = \frac{0.566}{t_m}$$

If it is demonstrated that for practical reasons the three values defined above cannot be obtained, then the minimum time t_{\min} may be utilized. However, the requirements of paragraph 1.3. below shall still apply.

1.1.4. The braking forces shall be calculated from the measured braking rate and the rolling resistance of the unbraked axle(s) which is equal to 0.015 and 0.010 of the static axle load for a driven axle and a non-driven axle, respectively.

1.1.5. The dynamic load on the axle shall be that given by the formulae in annex 10 to this Regulation.

1.1.6. The value of k shall be rounded to three decimal places.

1.1.7. Then, the test will be repeated for the other axle(s) as defined in paragraphs 1.1.1. to 1.1.6. above (for exemptions see paragraphs 1.4. and 1.5. below).

1.1.8. For example, in the case of a two-axle rear-wheel drive vehicle, with the front axle (1) being braked, the coefficient of adhesion

(k) is given by:

$$k_f = \frac{z_m \cdot P \cdot g - 0.015 \cdot F_2}{F_1 + \frac{h}{E} \cdot z_m \cdot P \cdot g}$$

1.1.9. One coefficient will be determined for the front axle k_f and one for the rear axle k_r .

1.2. Determination of the adhesion utilized (ϵ)

1.2.1. The adhesion utilized (ϵ) is defined as the quotient of the maximum braking rate with the anti-lock system operative (z_{AL}) and the coefficient of adhesion (k_M) i.e.,

$$\epsilon = \frac{z_{AL}}{k_M}$$

1.2.2. From an initial vehicle speed of 55 km/h, the maximum braking rate (z_{AL}) shall be measured with full cycling of the anti-lock braking system and based on the average value of three tests, as in paragraph 1.1.3. of this appendix, using the time taken for the speed to reduce from 45 km/h to 15 km/h, according to the following formula:

$$z_{AL} = \frac{0.849}{t_m}$$

1.2.3. The coefficient of adhesion k_M shall be determined by weighting with the dynamic axle loads.

$$k_M = \frac{k_f \cdot F_{fdyn} + k_r \cdot F_{rdyn}}{P \cdot g}$$

where:

$$F_{fdyn} = F_f + \frac{h}{E} \cdot z_{AL} \cdot P \cdot g$$

$$F_{rdyn} = F_r - \frac{h}{E} \cdot z_{AL} \cdot P \cdot g$$

1.2.4. The value of ϵ shall be rounded to two decimal places.

1.2.5. In the case of a vehicle equipped with an anti-lock system of categories 1 or 2, the value of z_{AL} will be based on the whole vehicle, with the anti-lock system operative, and the adhesion utilized (ϵ) is given by the same formula quoted in paragraph 1.2.1. of this appendix.

1.2.6. In the case of a vehicle equipped with an anti-lock system of category 3, the value of z_{AL} will be measured on each axle which

has at least one directly controlled wheel. For example, for a two-axle rear-wheel drive vehicle with an anti-lock system acting only on the rear axle (2), the adhesion utilized (ϵ) is given by:

$$\epsilon_2 = \frac{z_{AL} \cdot P \cdot g - 0.010 \cdot F_1}{k_2 \left(F_2 - \frac{h}{E} \cdot z_{AL} \cdot P \cdot g \right)}$$

This calculation shall be made for each axle having at least one directly controlled wheel.

- 1.3. If $\epsilon > 1.00$ the measurements of coefficients of adhesion shall be repeated. A tolerance of 10 per cent is accepted.
- 1.4. For power-driven vehicles equipped with three axles, only the axle not associated with a close-coupled bogie will be used to establish a k value for the vehicle. 1/
- 1.5. For vehicles of categories N_2 and N_3 with a wheelbase less than 3.80 m and with $h/E \geq 0.25$ the determination of the coefficient of adhesion for the rear axle will be omitted.
- 1.5.1. In that case the adhesion utilized (ϵ) is defined as the quotient of the maximum braking rate with the anti-lock system operative (z_{AL}) and the coefficient of adhesion (k_f) i.e.

$$\epsilon = \frac{z_{AL}}{k_f}$$

2. METHOD OF MEASUREMENT FOR TRAILERS

2.1. General

- 2.1.1. The coefficient of adhesion (k) shall be determined as the quotient of the maximum braking forces without locking the wheels and the corresponding dynamic load on the axle being braked.
- 2.1.2. The brakes shall be applied on only one axle of the trailer under test, at an initial speed of 50 km/h. The braking forces shall be distributed between the wheels of the axle to reach maximum performance. The anti-lock system shall be disconnected or inoperative, between 40 km/h and 20 km/h.
- 2.1.3. A number of tests at increments of line pressure shall be carried out to determine the maximum braking rate of the vehicle combination (z_{Cmax}) with the trailer only braked. During each test, a constant input force shall be maintained and the braking rate will be determined by reference to the time taken (t) for the speed to reduce from 40 km/h to 20 km/h using the formula:

1/ Until a uniform test procedure is agreed, vehicles with more than three axles and special vehicles will be subject to consultation with the Technical Service.

$$z_C = \frac{0.566}{t}$$

- 2.1.3.1. Wheel lock may occur below 20 km/h.
- 2.1.3.2. Starting from the minimum measured value of t , called t_{\min} , then select three values of t comprised within t_{\min} and $1.05 t_{\min}$ and calculate their arithmetical mean value t_m , then calculate

$$z_{Cmax} = \frac{0.566}{t_m}$$

If it is demonstrated that for practical reasons the three values defined above cannot be obtained, then the minimum time t_{\min} may be utilized.

- 2.1.4. The adhesion utilized (ϵ) shall be calculated by means of the formula:

$$\epsilon = \frac{z_{RAL}}{k_R}$$

The k value has to be determined according to paragraph 2.2.3. of this appendix for full trailers or paragraph 2.3.1. of this appendix for semi-trailers respectively.

- 2.1.5. If $\epsilon > 1.00$ the measurements of coefficients of adhesion shall be repeated. A tolerance of 10 per cent is accepted.
- 2.1.6. The maximum braking rate (z_{RAL}) shall be measured with full cycling of the anti-lock braking system and the towing vehicle unbraked, based on the average value of three tests, as in paragraph 2.1.3. of this appendix.

2.2. Full trailers

- 2.2.1. The measurement of k (with the anti-lock system being disconnected, or inoperative, between 40 km/h and 20 km/h) will be performed for the front and the rear axles.

For one front axle i :

$$F_{bRmaxi} = z_{Cmaxi} (F_M + F_R) - 0.01F_{Cnd} - 0.015F_{Cd}$$

$$F_{idyn} = F_i + \frac{z_{Cmax} (F_M \cdot h_D + g \cdot P \cdot h_R) - F_{WM} \cdot h_D}{E}$$

$$k_f = \frac{F_{bRmaxi}}{F_{idyn}}$$

For one rear axle i :

$$F_{bRmaxi} = z_{Cmaxi} \cdot (F_M + F_R) - 0.01F_{Cnd} - 0.015F_{Cd}$$

$$F_{idyn} = F_i - \frac{z_{Cmax} (F_M \cdot h_D + g \cdot P \cdot h_R) - F_{WM} \cdot h_D}{E}$$

$$k_r = \frac{F_{bRmaxi}}{F_{idyn}}$$

2.2.2. The values of k_f and k_x will be rounded to three decimal places.

2.2.3. The coefficient of adhesion k_R shall be determined proportionally according to the dynamic axle loads.

$$k_R = \frac{k_f \cdot F_{fdyn} + k_x \cdot F_{rdyn}}{P \cdot g}$$

2.2.4. Measurement of z_{RAL} (with the anti-lock system operative)

$$z_{RAL} = \frac{z_{CAL} \cdot (F_M + F_R) - 0.01F_{Cnd} - 0.015F_{Cd}}{F_R}$$

z_{RAL} is to be determined on a surface with a high coefficient of adhesion and, for vehicles with a category A anti-lock system, also on a surface with a low coefficient of adhesion.

2.3. Semi-trailers and centre-axle trailers

2.3.1. The measurement of k (with the anti-lock system being disconnected or inoperative, between 40 km/h and 20 km/h) shall be carried out with wheels fitted only on one axle, the wheels of the other axle(s) are removed.

$$F_{bRmax} = z_{Cmax} \cdot (F_M + F_R) - F_{WM}$$

$$F_{Rdyn} = F_R - \frac{F_{bRmax} \cdot h_K + z_c \cdot g \cdot P \cdot (h_R - h_K)}{E_R}$$

$$k = \frac{F_{bRmax}}{F_{Rdyn}}$$

2.3.2. The measurement of z_{RAL} (with the anti-lock system operative) shall be carried out with all wheels fitted.

$$F_{bRAL} = Z_{CAL} \cdot (F_M + F_R) - F_{WM}$$

$$F_{Rdyn} = F_R - \frac{F_{bRAL} \cdot h_K + z_c \cdot g \cdot P \cdot (h_R - h_K)}{E_R}$$

$$Z_{RAL} = \frac{F_{bRAL}}{F_{Rdyn}}$$

Z_{RAL} is to be determined on a surface with a high coefficient of adhesion and, for vehicles with a category A anti-lock system, also on a surface with a low coefficient of adhesion.

Annex 13 - Appendix 3

PERFORMANCE ON DIFFERING ADHESION SURFACES

1. Power-driven vehicles

1.1. The prescribed braking rate referred to in paragraph 5.3.5. of this annex may be calculated by reference to the measured coefficient of adhesion of the two surfaces on which this test is carried out. These two surfaces must satisfy the conditions prescribed in paragraph 5.3.4. of this annex.

1.2. The coefficient of adhesion (k_H and k_L) of the high- and low-adhesion surfaces, respectively, shall be determined in accordance with the provisions in paragraph 1.1. of appendix 2 to this annex.

1.3. The braking rate (z_{MALS}) for laden power-driven vehicles shall be:

$$z_{MALS} \geq 0.75 \frac{4k_L + k_H}{5} \quad \text{and} \quad z_{MALS} \geq k_L$$

2. Trailers

2.1. The braking rate referred to in paragraph 6.3.2. of this annex may be calculated by reference to the measured braking rates z_{RALH} and z_{RALL} on the two surfaces on which the tests are carried out with the anti-lock system operative. These two surfaces must satisfy the conditions prescribed in paragraph 6.3.2. of this annex.

2.2. The braking rate z_{RALS} shall be:

$$z_{RALS} \geq \frac{0.75}{\epsilon_H} \cdot \frac{4z_{RALL} + z_{RALH}}{5}$$

and

$$z_{RALS} > \frac{z_{RALL}}{\epsilon_H}$$

If $\epsilon_H > 0.95$, use $\epsilon_H = 0.95$

Annex 13 - Appendix 4

METHOD OF SELECTION OF THE LOW-ADHESION SURFACES

1. Details of the coefficient of adhesion of the surface selected, as defined in paragraph 5.1.1.2. of this annex, must be given to the Technical Service.
 - 1.1. These data must include a curve of the coefficient of adhesion versus slip (from 0 to 100 per cent slip) for a speed of approximately 40 km/h. 1/
 - 1.1.1. The maximum value of the curve will represent k_{peak} and the value at 100 per cent slip will represent k_{lock} .
 - 1.1.2. The ratio R shall be determined as the quotient of the k_{peak} and k_{lock} .

$$R = \frac{k_{peak}}{k_{lock}}$$

- 1.1.3. The value of R shall be rounded to one decimal place.
 - 1.1.4. The surface to be used must have a ratio R between 1.0 and 2.0. 2/
 2. Prior to the tests, the Technical Service shall ensure that the selected surface meets the specified requirements and shall be informed of the following:
 - (a) test method to determine R,
 - (b) type of vehicle (power-driven vehicle, trailer, ...),
 - (c) axle load and tyres (different loads and different tyres have to be tested and the results shown to the Technical Service which will decide if they are representative for the vehicle to be approved).
- 2.1. The value of R shall be mentioned in the test report.

The calibration of the surface has to be carried out at least once a year with a representative vehicle to verify the stability of R.

1/ Until a uniform test procedure is established for the determination of the adhesion curve for vehicles with a maximum mass exceeding 3.5 tonnes, the curve established for passenger cars may be used. In this case, for such vehicles, the ratio k_{peak} to k_{lock} shall be established using a value of k_{peak} as defined in appendix 2 to this annex. With the consent of the Technical Service, the coefficient of adhesion described in this paragraph may be determined by another method provided that the equivalence of the values of k_{peak} and k_{lock} are demonstrated.

2/ Until such test surfaces become generally available, a ratio R up to 2.5 is acceptable, subject to discussion with the Technical Service.

Annex 14

TEST CONDITIONS FOR TRAILERS WITH ELECTRICAL BRAKING SYSTEMS

1. GENERAL
 - 1.1. For the purposes of the following provisions electrical braking systems are service braking systems consisting of a control device, an electromechanical transmission device, and friction brakes. The electrical control device regulating the voltage for the trailer must be situated on the trailer.
 - 1.2. The electrical energy required for the electrical braking system is supplied to the trailer by the towing vehicle.
 - 1.3. Electrical braking systems shall be actuated by operating the service braking system of the towing vehicle.
 - 1.4. The nominal voltage rating shall be 12 V.
 - 1.5. The maximum current consumption shall not exceed 15 A.
 - 1.6. The electrical connection of the electrical braking system to the towing vehicle shall be effected by means of a special plug and socket connection corresponding to . . . , 1/ the plug of which shall not be compatible with the sockets of the lighting equipment of the vehicle. The plug together with the cable shall be situated on the trailer.
2. CONDITIONS CONCERNING THE TRAILER
 - 2.1. If there is a battery on the trailer fed by the power supply unit of the towing vehicle, it shall be separated from its supply line during service braking of the trailer.
 - 2.2. With trailers whose unladen mass is less than 75 per cent of their maximum mass, the braking force shall be automatically regulated as a function of the loading condition of the trailer.
 - 2.3. Electrical braking systems shall be such that even when the voltage in the connection lines is reduced to a value of 7 V, a braking effect of 20 per cent of the (sum of the) maximum stationary axle load(s) is maintained.

1/ Under study. Until the characteristics of this special connection have been determined, the type to be used will be indicated by the national authority granting the approval.

- 2.4. Control devices for regulating the braking force, which react to the inclination in the direction of travel (pendulum, spring-mass-system, liquid-inertia-switch) shall, if the trailer has more than one axle and a vertically adjustable towing device, be attached to the chassis. In the case of single-axle trailers and trailers with close-coupled axles where the axle spread is less than 1 metre, these control devices shall be equipped with a mechanism indicating its horizontal position (e.g., spirit level) and shall be manually adjustable to allow the mechanism to be set in the horizontal plane in line with the direction of travel of the vehicle.
- 2.5. The relay for actuating the braking current in accordance with paragraph 5.2.1.19.2. of this Regulation, which is connected to the actuating line, shall be situated on the trailer.
- 2.6. A dummy socket shall be provided for the plug.
- 2.7. A tell-tale shall be provided at the control device, lighting up at any brake application and indicating the proper functioning of the trailer electrical braking system.
3. PERFORMANCE
- 3.1. Electrical braking systems shall respond at a deceleration of the tractor/trailer combination of not more than 0.4 m/s^2 .
- 3.2. The braking effect may commence with an initial braking force, which shall not be higher than 10 per cent of the (sum of the) maximum stationary axle load(s) nor higher than 13 per cent of the (sum of the) stationary axle load(s) of the unladen trailer.
- 3.3. The braking forces may also be increased in steps. At higher levels of the braking forces than those referred to in paragraph 3.2. of this annex these steps shall not be higher than 6 per cent of the (sum of the) maximum stationary axle load(s) nor higher than 8 per cent of the (sum of the) stationary axle load(s) of the unladen trailer. However, in the case of single-axle trailers having a maximum mass not exceeding 1.5 tonnes, the first step must not exceed 7 per cent of the (sum of the) maximum stationary axle load(s) of the trailer. An increase of 1 per cent of this value is permitted for the subsequent steps (example: first step 7 per cent, second step 8 per cent, third step 9 per cent, etc; any further step should not exceed 10 per cent). For the purpose of these provisions a two-axle trailer having a wheelbase shorter than 1 m will be considered as a single axle trailer.
- 3.4. The prescribed braking force of the trailer of at least 50 per cent of the maximum total axle load shall be attained - with maximum mass - in the case of a mean fully developed deceleration of the tractor/trailer combination of not more than 5.9 m/s^2 with single-axle trailers and of not more than 5.6 m/s^2 with multi-axle trailers. Trailers with close-coupled axles where the axle spread is less than 1 m are also considered as single-axle trailers within the meaning of this provision. Moreover, the limits as defined in the appendix to this annex must be observed. If the braking force is regulated in steps, they shall lie within the range shown in the appendix to this annex.
- 3.5. The test shall be carried out with an initial speed of 60 km/h.
- 3.6. Automatic braking of the trailer shall be provided in accordance with the conditions of paragraph 5.2.2.9. of this Regulation. If this

automatic braking action requires electrical energy, a trailer braking force of at least 25 per cent of the maximum total axle load shall be achieved for at least 15 minutes to satisfy the above-mentioned conditions.

Annex 14 - Appendix

Compatibility of the braking rate of the trailer and the mean fully developed deceleration of the tractor/trailer combination (trailer laden and unladen).

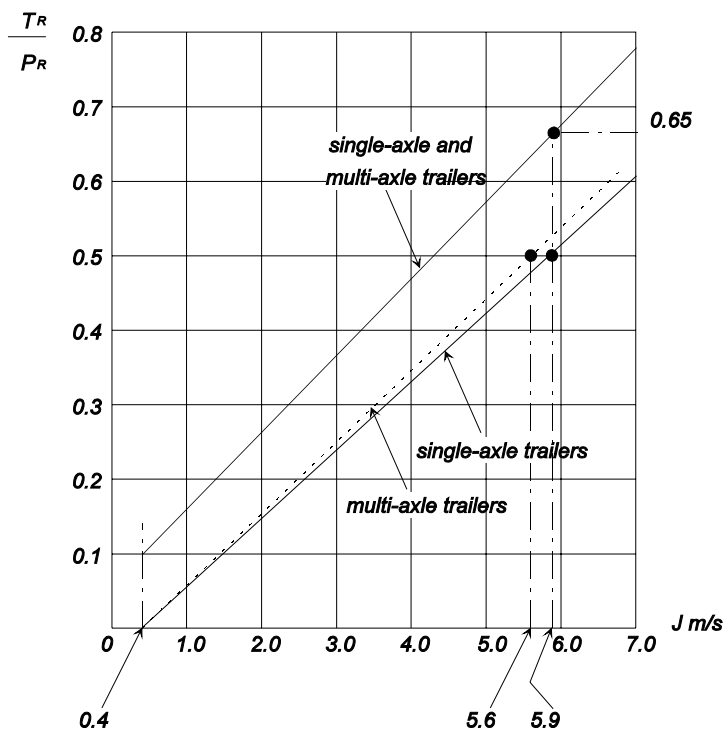

Notes:

1. Limits indicated in the diagram refer to laden and unladen trailers. When the trailer unladen mass exceeds 75 per cent of its maximum mass, limits shall be applied only to "laden" conditions.
2. Limits indicated in the diagram do not affect the provisions of this annex regarding the minimum braking performances required. However, if braking performances obtained during test - in accordance with provisions indicated in paragraph 3.4. of this annex - are greater than those required, said performances shall not exceed the limits indicated in the above diagram.

T_R = sum of braking forces at periphery of all wheels of trailer.
 P_R = total normal static reaction of road surface on wheels of trailer.
 J = mean fully developed deceleration of tractor/trailer combination.

Annex 15

INERTIA DYNAMOMETER TEST METHOD FOR BRAKE LININGS

1. GENERAL
 - 1.1. The procedure described in this annex may be applied in the event of a modification of vehicle type resulting from the fitting of brake linings of another type to vehicles which have been approved in accordance with this Regulation.
 - 1.2. The alternative types of brake linings shall be checked by comparing their performance with that obtained from the brake linings with which the vehicle was equipped at the time of approval and conforming to the components identified in the relevant information document, a model of which is given in annex 2 to this Regulation.
 - 1.3. The Technical Service responsible for conducting approval tests may at its discretion require comparison of the performance of the brake linings to be carried out in accordance with the relevant provisions contained in annex 4 to this Regulation.
 - 1.4. Application for approval by comparison shall be made by the vehicle manufacturer or by his duly accredited representative.
 - 1.5. In the context of this annex, "vehicle" shall mean the vehicle-type approved according to this Regulation and for which it is requested that the comparison shall be considered satisfactory.
2. TEST EQUIPMENT
 - 2.1. A dynamometer having the following characteristics shall be used for the tests:
 - 2.1.1. It shall be capable of generating the inertia required by paragraph 3.1. of this annex, and have the capacity to meet the requirements prescribed by paragraphs 1.5., 1.6. and 1.7. of annex 4 to this Regulation with respect to Type-I, Type-II and Type-III tests.
 - 2.1.2. The brakes fitted shall be identical with those of the original vehicle-type concerned.
 - 2.1.3. Air cooling, if provided, shall be in accordance with paragraph 3.4. of this annex.
 - 2.1.4. The instrumentation for the test shall be capable of providing at least the following data:
 - 2.1.4.1. a continuous recording of disc or drum rotational speed;
 - 2.1.4.2. number of revolutions completed during a stop, to a resolution not greater than one eighth of a revolution;
 - 2.1.4.3. stop time;
 - 2.1.4.4. a continuous recording of the temperature measured in the centre of the path swept by the lining or at mid-thickness of the disc or drum or lining;
 - 2.1.4.5. a continuous recording of brake application control line pressure

or force;

2.1.4.6. a continuous recording of brake output torque.

3. TEST CONDITIONS

3.1. The dynamometer shall be set as close as possible, with ± 5 per cent tolerance, to the rotary inertia equivalent to that part of the total inertia of the vehicle braked by the appropriate wheel(s) according to the following formula:

$$I = MR^2$$

where

I = rotational inertia [kgm²]

R = dynamic tyre rolling radius [m]

M = that part of the maximum mass of the vehicle braked by the appropriate wheel(s). In the case of a single-ended dynamometer, this part shall be calculated from the design braking distribution in the case of vehicles of categories M and N when deceleration corresponds to the appropriate value given in paragraph 2.1. of annex 4 to this Regulation; in the case of vehicles of category O (trailers) the value of M will correspond to the load on the ground for the appropriate wheel when the vehicle is stationary and loaded to its maximum mass.

3.2. The initial rotational speed of the inertia dynamometer shall correspond to the linear speed of the vehicle as prescribed in annex 4 to this Regulation and shall be based on the dynamic rolling radius of the tyre.

3.3. Brake linings shall be at least 80 per cent bedded and shall not have exceeded a temperature of 180 °C during the bedding procedure, or alternatively, at the vehicle manufacturer's request, be bedded in accordance with his recommendations.

3.4. Cooling air may be used, flowing over the brake in a direction perpendicular to its axis of rotation. The velocity of the cooling air flowing over the brake shall be not greater than 10 km/h. The temperature of the cooling air shall be the ambient temperature.

4. TEST PROCEDURE

4.1. Five sample sets of the brake lining shall be subjected to the comparison test; they shall be compared with five sets of linings conforming to the original components identified in the information document concerning the first approval of the vehicle type concerned.

4.2. Brake lining equivalence shall be based on a comparison of the results achieved using the test procedures prescribed in this annex and in accordance with the following requirements.

4.3. Type-0 cold performance test

4.3.1. Three brake applications shall be made when the initial

temperature is below 100°C. The temperature shall be measured in accordance with the provisions of paragraph 2.1.4.4. of this annex.

- 4.3.2. In the case of brake linings intended for use on vehicles of categories M and N, brake applications shall be made from an initial rotational speed equivalent to that given in paragraph 2.1. of annex 4 to this Regulation, and the brake shall be applied to achieve a mean torque equivalent to the deceleration prescribed in that paragraph. In addition, tests shall also be carried out at several rotational speeds, the lowest being equivalent to 30 per cent of the maximum speed of the vehicle and the highest being equivalent to 80 per cent of that speed.
- 4.3.3. In the case of brake linings intended for use on vehicles of category O, brake applications shall be made from an initial rotational speed equivalent to 60 km/h, and the brake shall be applied to achieve a mean torque equivalent to that prescribed in paragraph 3.1. of annex 4 to this Regulation. A supplementary cold performance test from an initial rotational speed equivalent to 40 km/h shall be carried out for comparison with the Type-I test results as described in paragraph 3.1.2.2. of annex 4 to this Regulation.
- 4.3.4. The mean braking torque recorded during the above cold performance tests on the linings being tested for the purpose of comparison shall, for the same input measurement, be within the test limits ± 15 per cent of the mean braking torque recorded with the brake linings conforming to the component identified in the relevant application for vehicle type approval.
- 4.4. Type-I test (fade test)
- 4.4.1. With repeated braking
- 4.4.1.1. Brake linings for vehicles of categories M and N shall be tested according to the procedure given in paragraph 1.5.1. of annex 4 to this Regulation.
- 4.4.2. With continuous braking
- 4.4.2.1. Brake linings for trailers (category O) shall be tested in accordance with paragraph 1.5.2. of annex 4 to this Regulation.
- 4.4.3. Hot performance
- 4.4.3.1. On completion of the tests required under paragraphs 4.4.1. and 4.4.2. of this annex, the hot braking performance test specified in paragraph 1.5.3. of annex 4 to this Regulation shall be carried out.
- 4.4.3.2. The mean braking torque recorded during the above hot performance tests on the linings being tested for the purpose of comparison shall, for the same input measurement, be within the test limits ± 15 per cent of the mean braking torque recorded with the brake linings conforming to the component identified in the relevant application for vehicle type approval.
- 4.5. Type-II test (downhill behaviour test):
- 4.5.1. This test is required only if, on the vehicle-type in question, the friction brakes are used for the Type-II test.

- 4.5.2. Brake linings for power-driven vehicles of category M_3 (except for those vehicles required to undergo a Type-III test according to paragraph 1.6.4. of annex 4 to this Regulation) and category N_3 , and trailers of category O_4 shall be tested according to the procedure set out in paragraph 1.6.1. of annex 4 to this Regulation.
- 4.5.3. Hot performance
- 4.5.3.1. On completion of the test required under paragraph 4.5.1. of this annex, the hot performance test specified in paragraph 1.6.3. of annex 4 to this Regulation shall be carried out.
- 4.5.3.2. The mean braking torque recorded during the above hot performance tests on the linings being tested for the purpose of comparison shall, for the same input measurement, be within the test limits ± 15 per cent of the mean braking torque recorded with the brake linings conforming to the component identified in the relevant application for vehicle type approval.
- 4.6. Type-III test (fade test)
- 4.6.1. Test with repeated braking
- 4.6.1.1. Brake linings for trailers of category O_4 , shall be tested according to the procedure given in paragraphs 1.7.1. and 1.7.2. of annex 4 to this Regulation.
- 4.6.2. Test with continuous braking
- 4.6.2.1. Brake linings for trailers of category O_4 shall be tested according to the procedure given in paragraph 1.7. of annex 4 to this Regulation.
- 4.6.3. Hot performance
- 4.6.3.1. On completion of the tests required under paragraphs 4.6.1. and 4.6.2. of this annex, the hot braking performance test specified in paragraph 1.7.4. of annex 4 to this Regulation shall be carried out.
- 4.6.3.2. The mean braking torque during the above hot performance tests on the linings being tested for the purpose of comparison shall, for the same input measurement, be within the test limits ± 15 per cent of the mean braking torque recorded with the brake linings conforming to the component identified in the relevant application for vehicle type approval.
5. INSPECTION OF BRAKE LININGS
- 5.1. Brake linings shall be visually inspected on completion of the above tests to check that they are in satisfactory condition for continued use in normal service.
-