

29 November 2011

---

## Agreement

### **Concerning the adoption of uniform technical prescriptions for wheeled vehicles, equipment and parts which can be fitted and/or be used on wheeled vehicles and the conditions for reciprocal recognition of approvals granted on the basis of these prescriptions\***

(Revision 2, including the amendments entered into force on 16 October 1995)

---

### **Addendum 50: Regulation No. 51**

#### **Revision 2**

Incorporating all valid text up to:

02 series to the original version of the Regulation - Date of entry into force: 18 April 1995  
Supplement 1 to the 02 series of amendments - Date of entry into force: 05 May 1996  
Corrigendum 1 to the 02 series of amendments - Date of entry into force: 15 November 1996  
Corrigendum 2 to the 02 series of amendments - Date of entry into force: 11 Mars 1998  
Corrigendum 1 to Supplement 3 to 02 series of amendments - Date of entry into force: 07 March 2001  
Supplement 4 to 02 series of amendments - Date of entry into force: 02 February 2007  
Supplement 5 to 02 series of amendments - Date of entry into force: 18 June 2007  
Supplement 6 to 02 series of amendments - Date of entry into force: 03 February 2008  
Supplement 7 to 02 series of amendments - Date of entry into force: 30 January 2011  
Corrigendum 3 to 02 series of amendments - Date of entry into force: 09 March 2011

### **Uniform provisions concerning the approval of motor vehicles having at least four wheels with regard to their noise emissions**



UNITED NATIONS

---

\* Former title of the Agreement: Agreement Concerning the Adoption of Uniform Conditions of Approval and Reciprocal Recognition Vehicle Equipment and Parts, done at Geneva on 20 March 1958.



## Regulation No. 51

### Uniform provisions concerning the approval of motor vehicles having at least four wheels with regard to their noise emissions

#### Contents

	<i>Page</i>
1. Scope .....	4
2. Definitions .....	4
3. Application for approval .....	6
4. Markings .....	7
5. Approval .....	7
6. Specifications .....	8
7. Modification and extension of approval of a vehicle type .....	10
8. Conformity of production.....	10
9. Penalties for non-conformity of production .....	11
10. Production definitively discontinued.....	12
11. Transitional provisions.....	12
12. Names and addresses of Technical Services responsible for conducting approval tests and of Type Approval Authorities.....	12
<b>Annexes</b>	
1. Communication.....	13
2. Arrangements of the approval mark.....	17
3. Methods and instruments for measuring the noise made by motor vehicles (measurement method A).....	18
Appendix: Measuring positions for vehicles in motion.....	28
4. Classification of vehicles .....	31
5. Silencing systems containing acoustically absorbing fibrous materials.....	33
Appendix: Figure 3 .....	35
6. Compressed air noise .....	36
Appendix: Figure 1 .....	37
7. Checks on conformity of production.....	38
8. Specifications for the test site.....	39
9. Vehicle test data pursuant to measurement method B.....	46
10. Methods and instruments for measuring the noise made by motor vehicles (measurement method B).....	49

## 1. Scope

This Regulation applies to vehicles of category M and N<sup>1</sup> with regard to noise.

## 2. Definitions

For the purpose of this Regulation,

- 2.1. "Approval of a vehicle" means the approval of a vehicle type with regard to noise;
- 2.2. "Vehicle type" means a category of motor vehicles which do not differ in such essential respects as:
  - 2.2.1. The shape or materials of the bodywork (particularly the engine compartment and its soundproofing);
  - 2.2.2. The length and width of the vehicle;
  - 2.2.3. The type of engine (positive or compression ignition, two - or four-stroke, reciprocating or rotary piston), number and capacity of cylinders, number and type of carburettors or injection system, arrangement of valves, rated maximum power and corresponding engine speed(s), or the type of electric motor;
  - 2.2.4. The transmission system, the number of gears and ratios;
  - 2.2.5. The noise reduction system as defined in the following paragraphs 2.3. and 2.4.
  - 2.2.6. Notwithstanding the provisions of paragraphs 2.2.2. and 2.2.4., vehicles other than those in categories M<sub>1</sub> and N<sub>1</sub><sup>1</sup> having the same type of engine and/or different overall gear ratios, may be regarded as vehicles of the same type. However, if the above differences provide for a different test method, these differences are to be considered as a change of type.
- 2.3. "Noise reduction system" means a complete set of components necessary for limiting the noise made by a motor vehicle and its exhaust;
- 2.4. "Noise reduction systems of different types" means noise reduction systems which differ in such essential respects as:
  - 2.4.1. That their components as specified in paragraph 4.1., bear different trade names or marks;
  - 2.4.2. That the characteristics of the materials constituting a component are different or that the components differ in shape or size, a change in the plating procedure (galvanization, aluminium coating, etc.) is not deemed to produce a difference of type;
  - 2.4.3. That the operating principles of at least one component are different;
  - 2.4.4. That their components are assembled differently;

---

<sup>1</sup> As defined in the Consolidated resolution on the Construction of vehicles (R.E.3), document ECE/TRANS/WP.29/78/Rev.2, para.2.

- 2.4.5. That the number of the intake and/or exhaust silencers is different.
- 2.5. "*Noise reduction system component*" means one of the individual constituent parts whose assembly constitutes the noise reduction system.  
These components are, in particular: the exhaust pipings, the expansion chamber(s), the silencer(s) proper.
- 2.5.1. The air filter is considered as a component only if its presence is essential to ensure observance of the prescribed sound-level limits.
- 2.5.2. Manifolds are not considered components of the noise reduction system.
- 2.6. "*Maximum mass*" means the technically permissible maximum mass declared by the vehicle manufacturer (this mass may be greater than the maximum mass authorized by the national administration).
- 2.7. "*Rated engine power*" means the engine power expressed in kW (ECE) and measured by the ECE method pursuant to Regulation No. 85.
- 2.8. "*Mass of a vehicle in running order ( $m_{ro}$ )*" means the mass of an unladen vehicle with bodywork, and with coupling device in the case of a towing vehicle, or the mass of the chassis with cab if the manufacturer does not fit the bodywork and/or coupling device, including coolant, oils, 90 per cent of fuel, 100 per cent of other liquids except used waters, tools, spare wheel, driver (75 kg) and, for buses and coaches, the mass of the crew member (75 kg) if there is a crew seat in the vehicle.
- 2.9. "*Rated engine speed,  $S$* " means the declared engine speed in  $\text{min}^{-1}$  (rpm) at which the engine develops its rated maximum net power pursuant to Regulation No. 85.  
If the rated maximum net power is reached at several engine speeds, the highest engine speed shall be used.
- 2.10. "*Power to mass ratio index (PMR)*" means a numerical quantity (see annex 10, paragraph 3.1.2.1.1.) with no. dimension used for the calculation of acceleration.
- 2.11. "*Reference point*" means a point which is defined as follows:
- 2.11.1. Category  $M_1, N_1$ :
- (a) For front engine vehicles: the front end of the vehicle;
  - (b) For mid engine vehicles: the centre of the vehicle;
  - (c) For rear engine vehicles: the rear end of the vehicle.
- 2.11.2. Category  $M_2, M_3, N_2, N_3$ :  
The border of the engine closest to the front of the vehicle.
- 2.12. "*Engine*" means the power source without detachable accessories.
- 2.13. "*Target acceleration*" means an acceleration at a partial throttle condition in urban traffic and is derived from statistical investigations.
- 2.14. "*Reference acceleration*" means the required acceleration during the acceleration test on the test track.
- 2.15. "*Gear ratio weighting factor  $k$* " means a dimensionless numerical quantity used to combine the test results of two gear ratios for the acceleration test and the constant speed test.

- 2.16. "Partial power factor  $k_p$ " means a numerical quantity with no dimension used for the weighted combination of the test results of the acceleration test and the constant speed test for vehicles.
- 2.17. "Pre-acceleration" means application of acceleration control device prior to AA' for the purpose of achieving stable acceleration between AA' and BB'.
- 2.18. "Locked gear ratios" means the control of transmission such that the transmission gear cannot change during a test.
- 2.19. "Design family of silencing system or silencing system components"
- Silencing systems or components thereof belong to the same design family if all of the following characteristics are the same:
- (a) The exhaust gases in contact with the absorbing fibrous material have net gas flow through this material: (yes or no);
  - (b) The type of the fibres (e.g. basalt wool, biosil wool, glass wool, Etype wool, etc.);
  - (c) Binder material specifications (if applicable);
  - (d) Average fibre dimensions (thickness, length);
  - (e) Minimum bulk material packing density ( $\text{kg/m}^3$ );
  - (f) Maximum contact surface between the gas flow and the absorbing material (e.g. perforation open area).

### **3. Application for approval**

- 3.1. The application for approval of a vehicle type with regard to noise shall be submitted by its manufacturer or by his duly accredited representative.
- 3.2. It shall be accompanied by the undermentioned documents and the following particulars in triplicate:
- 3.2.1. A description of the vehicle type with regard to the items mentioned in paragraph 2.2. above. The numbers and/or symbols identifying the engine type and the vehicle type shall be specified;
  - 3.2.2. A list of the components, duly identified, constituting the noise reduction system;
  - 3.2.3. A drawing of the assembled noise reduction system and an indication of its position on the vehicle;
  - 3.2.4. Detailed drawings of each component to enable it to be easily located and identified, and a specification of the materials used.
- 3.3. In the case of paragraph 2.2.6. the single vehicle, representative of the type in question, will be selected by the Technical Service conducting approval tests, in accordance with the vehicle manufacturer, as that with the lowest mass in running order with the shortest length and following the specification laid down in paragraph 3.1.2.3.2.3. in Annex 3.
- 3.4. At the request of the Technical Service conducting approval tests, the vehicle manufacturer shall, in addition, submit a sample of the noise reduction system and an engine of at least the same cylinder capacity and rated maximum power as that fitted to the vehicle in respect of which type-approval is sought.

- 3.5. The competent authority shall verify the existence of satisfactory arrangements for ensuring effective control of the conformity of production before type approval is granted.

## **4. Markings**

- 4.1. The components of the noise reduction system, excluding fixing hardware and piping, shall bear:
- 4.1.1. The trade name or mark of the manufacturer of the noise reduction system and of its components; and
- 4.1.2. The manufacturer's trade description;
- 4.2. These markings shall be clearly legible and be indelible even after fitting.
- 4.3. A component may carry several approval numbers if it has been approved as component of several replacement silencing systems.

## **5. Approval**

- 5.1. Type approval shall only be granted if:
- (a) The vehicle type meets the requirements of paragraphs 6. and 7. below when tested according to measurement method A of Annex 3, and
- (b) Starting at 1 July 2007 and for a maximum period of two years, the results of the test run of that vehicle type in accordance with the measurement method B of Annex 10 have been added to the test report in Annex 9 and communicated to the European Commission and those Contracting Parties that express an interest in receiving the data. This does not include any tests done in connection with the extension of existing approvals according to Regulation No. 51. Furthermore, for the purpose of this monitoring procedure a vehicle is not considered to be a new type if the vehicle differs only in respect to paragraphs 2.2.1. and 2.2.2.
- 5.2. An approval number shall be assigned to each type approved. Its first two digits (at present 02 corresponding to the 02 series of amendments which entered into force on 18 April 1995) shall indicate the series of amendments incorporating the most recent major technical amendments made to the Regulation at the time of issue of the approval. The same Contracting Party may not assign the same number to the same vehicle type equipped with another type of noise reduction system or to another vehicle type.
- 5.3. Notice of approval or of extension or of refusal or withdrawal of approval or of production definitively discontinued of a vehicle type pursuant to this Regulation shall be communicated to the Parties to the Agreement applying this Regulation, by means of a form conforming to the model in Annex 1 to this Regulation.
- 5.4. There shall be affixed, conspicuously and in a readily accessible place specified on the approval form, to every vehicle conforming to a vehicle type approved under this Regulation an international approval mark consisting of:

- 5.4.1. A circle surrounding the letter "E" followed by the distinguishing number of the country which has granted approval<sup>2</sup>;
- 5.4.2. The number of this Regulation, followed by the letter "R", a dash and the approval number to the right of the circle prescribed in paragraph 5.4.1.
- 5.5. If the vehicle conforms to a vehicle type approved, under one or more other Regulations annexed to the Agreement, in the country which has granted approval under this Regulation, the symbol prescribed in paragraph 5.4.1. need not be repeated; in such a case the regulation and approval numbers and the additional symbols of all the Regulations under which approval has been granted in the country which has granted approval under this Regulation shall be placed in vertical columns to the right of the symbol prescribed in paragraph 5.4.1.
- 5.6. The approval mark shall be clearly legible and be indelible.
- 5.7. The approval mark shall be placed close to or on the vehicle data plate affixed by the manufacturer.
- 5.8. Annex 2 to this Regulation gives examples of arrangements of the approval mark.

## **6. Specifications**

- 6.1. General specifications
  - 6.1.1. The vehicle, its engine and its noise reduction system shall be so designed, constructed and assembled as to enable the vehicle, in normal use, despite the vibration to which it may be subjected, to comply with the provisions of this Regulation.
  - 6.1.2. The noise reduction system shall be so designed, constructed and assembled as to be able to reasonably resist the corrosive phenomena to which it is exposed having regard to the conditions of use of the vehicle.
- 6.2. Specifications regarding sound levels
  - 6.2.1. Methods of measurement
    - 6.2.1.1. The noise made by the vehicle type submitted for approval shall be measured by the two methods described in Annex 3 to this Regulation for the vehicle in motion and for the vehicle when stationary<sup>3</sup>; in the case of a vehicle where an internal combustion engine does not operate when the vehicle is stationary, the emitted noise shall only be measured in motion.  
  
Vehicles having a maximum permissible mass exceeding 2,800 kg shall be subjected to an additional measurement of the compressed air noise with the vehicle stationary in accordance with the specifications of Annex 6, if the corresponding brake equipment is part of the vehicle.

---

<sup>2</sup> The distinguish numbers of the Contracting Parties to the 1958 Agreement are reproduced in Annex 3 to Consolidated Resolution on the Construction of Vehicles (R.E.3), document ECE/TRANS/WP.29/78/Rev.2.

<sup>3</sup> A test is made on a stationary vehicle in order to provide a reference value for administrations which use this method to check vehicles in use.



6.2.1.2. The two values measured in accordance with the provisions of paragraph 6.2.1.1. above shall be entered in the test report and on a form conforming to the model in Annex 1 to this Regulation.

The values measured as specified in paragraph 6.2.1.1. above must be recorded in a test report and a certificate corresponding to the model shown in Annex 1.

6.2.2. Sound level limits

6.2.2.1. Subject to the provisions of paragraph 6.2.2.2. below, the sound level of vehicle types, as measured by the method described in paragraph 3.1. of Annex 3 to this Regulation, shall not exceed the following limits:

<i>Vehicle categories</i>		<i>Limit values (dB(A))</i>
6.2.2.1.1.	Vehicles used for the carriage of passengers and capable of having not more than nine seats, including the driver's seat	74
6.2.2.1.2.	Vehicles used for the carriage of passengers having more than nine seats, including the driver's seat, and a maximum authorized mass of more than 3.5 tonnes	
6.2.2.1.2.1.	with an engine power less than 150 kW (ECE)	78
6.2.2.1.2.2.	with an engine power of 150 kW (ECE) or above	80
6.2.2.1.3.	Vehicles used for the carriage of passengers having more than nine seats, including the driver's seat; vehicles used for the carriage of goods	
6.2.2.1.3.1.	with a maximum authorized mass not exceeding 2 tonnes	76
6.2.2.1.3.2.	with a maximum authorized mass greater than 2 tonnes but not exceeding 3.5 tonnes	77
6.2.2.1.4.	Vehicles used for the transport of goods with a maximum authorized mass exceeding 3.5 tonnes	
6.2.2.1.4.1.	with an engine power less than 75 kW (ECE)	77
6.2.2.1.4.2.	with an engine power of 75 kW (ECE) or above but less than 150 kW (ECE)	78
6.2.2.1.4.3.	with an engine power of 150 kW (ECE) or above	80

- 6.2.2.2. However;
- 6.2.2.2.1. For the vehicle types mentioned in paragraphs 6.2.2.1.1. and 6.2.2.1.3. equipped with a compression-ignition and directinjection internal combustion engine, the limit values shall be increased by 1 dB(A);
- 6.2.2.2.2. For vehicle types designed for off-road<sup>4</sup> use and with a maximum authorized mass above 2 tonnes, the limit values shall be increased:
  - 6.2.2.2.2.1. By 1 dB(A) if they are equipped with an engine having a power of less than 150 kW (ECE);
  - 6.2.2.2.2.2. By 2 dB(A) if they are equipped with an engine having a power of 150 kW (ECE) or above.
- 6.2.2.2.3. For vehicle types mentioned in paragraph 6.2.2.1.1. fitted with a gear box having more than four forward gears and equipped with an engine developing a maximum power greater than 140 kW (ECE) and having a maximum-power/maximum-mass ratio greater than 75 kW/t, the limit values shall be increased by 1 dB(A), if the speed at which the rear of the vehicle passes the line BB' in third gear is greater than 61 km/h.
- 6.3. Specifications regarding exhaust systems containing fibrous materials
- 6.3.1. Requirements of Annex 5 shall be applied.

## **7. Modification and extension of approval of a vehicle type**

- 7.1. Every modification of the vehicle type shall be notified to the Type Approval Authority which approved the vehicle type. The department may then either:
  - 7.1.1. Consider that the modifications made are unlikely to have an appreciable adverse effect and that in any case the vehicle still complies with the requirements, or
  - 7.1.2. Require a further test report from the Technical Service responsible for conducting the tests.
- 7.2. Confirmation or refusal of approval, specifying the alterations shall be communicated by the procedure specified in paragraph 5.3. above to the Parties to the Agreement applying this Regulation.
- 7.3. The competent authority issuing the extension of approval shall assign a series number for such an extension and inform thereof the other Parties to the 1958 Agreement applying this Regulation by means of a communication form conforming to the model in Annex 1 to this Regulation.

## **8. Conformity of production**

- 8.1. Vehicles approved to this Regulation shall be so manufactured as to conform to the type approved by meeting the requirements set forth in paragraph 6 above.

---

<sup>4</sup> In conformity with the definitions given in the Consolidated Resolution on the Construction of Vehicles (R.E.3) (TRANS/WP.29/78/Rev.1/Amend.2, annex 7/Rev.2).

- 8.2. In order to verify that the requirements of paragraph 8.1. are met, suitable controls of the production shall be carried out.
- 8.3. The holder of the approval shall in particular
  - 8.3.1. Ensure existence of procedures for the effective control of the quality of products;
  - 8.3.2. Have access to the control equipment necessary for checking the conformity of each approved type;
  - 8.3.3. Ensure that data of test results are recorded and that annexed documents shall remain available for a period to be determined in accordance with the Type Approval Authorities;
  - 8.3.4. Analyze the results of each type of test, in order to verify and ensure the stability of the product characteristics making allowance for variation of an industrial production;
  - 8.3.5. Ensure that for each type of product at least the tests prescribed in Annex 7 to this Regulation are carried out;
  - 8.3.6. Ensure that any sampling or test pieces giving evidence of non-conformity with the type of test considered shall give rise to another sampling and another test. All the necessary steps shall be taken to re-establish the conformity of the corresponding production.
- 8.4. The competent authority which has granted type-approval may at any time verify the conformity control method applicable to each production unit.
  - 8.4.1. In every inspection the test books and production survey records shall be presented to the visiting inspector.
  - 8.4.2. The inspector may take samples at random which will be tested in the manufacturer's laboratory. The minimum number of samples may be determined according to the results of the manufacturer's own verification.
  - 8.4.3. When the quality level appears unsatisfactory or when it seems necessary to verify the validity of the tests carried out in application of paragraph 8.4.2. the inspector shall select samples to be sent to the Technical Service which has conducted the type approval tests.
  - 8.4.4. The competent authority may carry out any test prescribed in this Regulation.
  - 8.4.5. The normal frequency of inspections by the competent authority shall be one every two years. If unsatisfactory results are recorded during one of these visits, the competent authority shall ensure that all necessary steps are taken to re-establish the conformity of production as rapidly as possible.

## **9. Penalties for non-conformity of production**

- 9.1. The approval granted in respect of a vehicle type pursuant to this Regulation may be withdrawn if the requirements set forth above are not met.
- 9.2. If a Contracting Party to the Agreement applying this Regulation withdraws an approval it has previously granted, it shall forthwith so notify the other Contracting Parties applying this Regulation, by means of a communication form conforming to the model in Annex 1 to this Regulation.

## **10. Production definitively discontinued**

- 10.1. If the holder of the approval completely ceases to manufacture a vehicle type approved in accordance with this Regulation, he shall so inform the authority which granted the approval. Upon receiving the relevant communication that authority shall inform thereof the other Parties to the 1958 Agreement applying this Regulation by means of a communication form conforming to the model in Annex 1 to this Regulation.

## **11. Transitional provisions**

- 11.1. As from the official date of entry into force of the 02 series of amendments, no Contracting Party applying this Regulation shall refuse to grant ECE approval under this Regulation as amended by the 02 series of amendments.
- 11.2. As from 1 October 1995, Contracting Parties applying this Regulation shall grant ECE approvals only if the vehicle type to be approved meets the requirements of this Regulation as amended by the 02 series of amendments.
- 11.3. As from 1 October 1996, Contracting Parties applying this Regulation may refuse first national registration (first entry into service) of a vehicle which does not meet the requirements of the 02 series of amendments to this Regulation.

## **12. Names and addresses of Technical Services responsible for conducting approval tests and of Type Approval Authorities**

The Parties to the 1958 Agreement applying this Regulation shall communicate to the United Nations Secretariat the names and addresses of the Technical Services responsible for conducting approval tests and of the Type Approval Authorities which grant approval and to which forms certifying approval or extension or refusal or withdrawal of approval, issued in other countries, are to be sent.

## Annex 1

### Communication

(maximum format: A4 (210 x 297 mm))

issued by: Name of administration:

.....  
.....  
.....

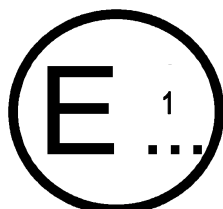

concerning:<sup>2</sup> APPROVAL GRANTED  
APPROVAL EXTENDED  
APPROVAL REFUSED  
APPROVAL WITHDRAWN  
PRODUCTION DEFINITELY DISCONTINUED

of a vehicle type with regard to its noise emission pursuant ECE to Regulation No. 51

Approval No. .... Extension No. ....

1. Trade name or mark of the vehicle: .....
2. Vehicle type: .....
- 2.1. Maximum permissible mass including semi-trailer (where applicable) .....  
.....
3. Manufacturer's name and address .....
4. If applicable, name and address of manufacturer's representative .....  
.....
5. Engine:
  - 5.1. Manufacturer: .....
  - 5.2. Type: .....
  - 5.3. Model: .....
  - 5.4. Rated maximum power (ECE): ..... kW at ..... rev/min.
  - 5.5. Kind of engine: e.g. positive-ignition, compression ignition, etc.<sup>3</sup> .....  
.....
  - 5.6. Cycles: two stroke or four-stroke (if applicable) .....

<sup>1</sup> Distinguishing number of the country which has granted/extended/refused/withdrawn approval (see approval provisions in the Regulation).

<sup>2</sup> Delete what does not apply

<sup>3</sup> If a non-conventional engine is used, this should be stated.

- 5.7. Cylinder capacity (if applicable).....
6. Transmission: non-automatic gearbox/automatic gearbox<sup>2</sup>.....
- 6.1. Number of gears .....
7. Equipment:
- 7.1. Exhaust silencer:.....
- 7.1.1. Manufacturer or authorized representative (if any) .....
- .....
- 7.1.2. Model: .....
- 7.1.3. Type: ..... in accordance with drawing No.: .....
- 7.2. Intake silencer: .....
- 7.2.1. Manufacturer or authorized representative (if any) .....
- .....
- 7.2.2. Model:.....
- 7.2.3. Type: ..... in accordance with drawing No.: .....
- 7.3. Tyre size (by axle): .....
8. Measurements:
- 8.1. Sound level of moving vehicle:

<i>Measurement results</i>			
	Left-hand side dB(A) <sup>4</sup>	Right-hand side dB(A) <sup>4</sup>	Position of gear lever
First measurement			
Second measurement			
Third measurement			
Fourth measurement			
Test result: .....			dB (A)

<sup>4</sup> The measurement values are given with the 1 dB(A) deduction in accordance with the provisions of paragraph 6.2.2.1.

8.2. Sound level of stationary vehicle:

Position and orientation of microphone (according to diagrams in appendix of annex 3)

<i>Measurement results</i>		
	dB(A)	Engine speed
First measurement		
Second measurement		
Third measurement		
Test result: ..... dB (A)		

8.3. Sound level of compressed air noise:

<i>Measurement results</i>		
	Left-hand side dB(A) <sup>4</sup>	Right-hand side dB(A) <sup>4</sup>
First measurement		
Second measurement		
Third measurement		
Fourth measurement		
Test result: ..... dB (A)		

8.4. Ambient conditions

8.4.1. Test site (surface characteristics): .....

8.4.2. Temperatures (in °C): .....

8.4.2.1. Temperature of ambient air: .....

8.4.2.2. Temperature of test track surface: .....

8.4.3. Atmospheric pressure (kPa): .....

8.4.4. Humidity (%): .....

8.4.5. Wind speed (km/h): .....

8.4.6. Wind direction: .....

8.4.7. Background noise (dB(A)): .....

9. Vehicle submitted for approval on: .....

10. Technical Service responsible for type-approval tests: .....

11. Date of test report issued by that service: .....

12. Number of test report issued by that service: .....

13. Type-approval in respect of sound levels is hereby granted/extended/refused/withdrawn<sup>2</sup>

14. Position of approval mark on the vehicle .....

- 15. Place: .....
- 16. Date: .....
- 17. Signature:.....
- 18. The following documents, bearing the approval number shown above, are annexed to this communication:  
  
Drawings, diagrams and plans of the engine and of the noise reduction system;  
  
Photographs of the engine and of the noise reduction system;  
  
List of components, duly identified constituting the noise reduction system.
- 19. Remarks:.....  
.....  
.....



## Annex 2

### Arrangements of the approval mark

Model A  
(See paragraph 5.4. of this Regulation)

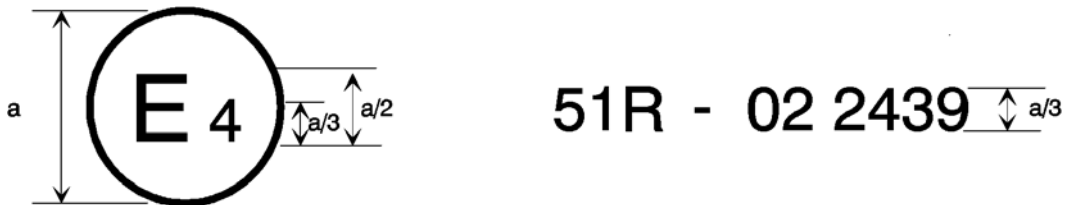

$a = 8 \text{ mm min.}$

The above approval mark affixed to a vehicle shows that the vehicle type concerned has, with regard to its noise emission, been approved in the Netherlands (E 4) pursuant to Regulation No. 51 under approval No. 022439.

The first two digits of the approval number indicate that Regulation No. 51 already included the 02 series of amendments when the approval was granted.

Model B  
(See paragraph 5.5. of this Regulation)

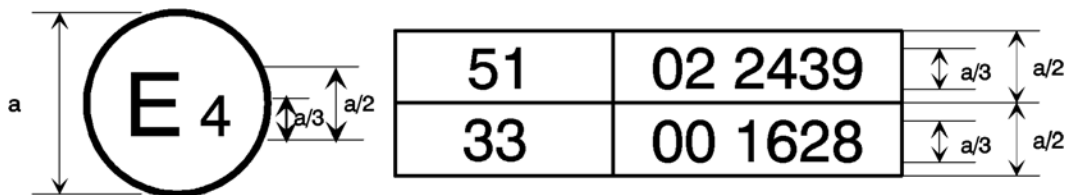

$a = 8 \text{ mm min.}$

The above approval mark affixed to a vehicle shows that the vehicle type concerned has been approved in the Netherlands (E 4) pursuant to Regulations Nos. 51 and 33.<sup>1</sup> The approval numbers indicate that, at the dates when the respective approvals were granted, Regulation No. 51 included the 02 series of amendments while Regulation No. 33 was in its original form.

<sup>1</sup> The latter number is given as an example only.

## Annex 3

### Methods and instruments for measuring the noise made by motor vehicles (measurement method A)

1. Measuring instruments
  - 1.1. Acoustic measurements

The sound level meter or the equivalent measuring system, including the windscreen recommended by the manufacturer shall at least meet the requirements of Type 1 instruments in accordance with IEC 651, second edition.

The measurements shall be made using the frequency weighting A, and the time weighting F.

When using a system that includes a periodic monitoring of the A-weighted sound level, a reading should be made at a time interval not greater than 30 ms.
  - 1.1.1. Calibration

At the beginning and at the end of every measurement session the entire measurement system shall be checked by means of a sound calibrator that fulfils the requirements for sound calibrators of at least precision Class 1 according to IEC 942:1988. Without any further adjustment the difference between the readings of two consecutive checks shall be less than or equal to 0.5 dB.

If this value is exceeded the results of the measurements obtained after the previous satisfactory check shall be discarded.
  - 1.1.2. Compliance with requirements

The compliance of the sound calibration device with the requirements of IEC 942:1988 shall be verified once a year and the compliance of the instrumentation system with the requirements of IEC 651, second edition shall be verified at least every two years, by a laboratory which is authorized to perform calibrations traceable to the appropriate standards.
  - 1.2. Speed measurements

The rotational speed of the engine and the vehicle speed shall be measured with instruments with an accuracy of  $\pm 2$  per cent or better.
  - 1.3. Meteorological instrumentation

The meteorological instrumentation used to monitor the environmental conditions shall include the following:

    - (i) A temperature measuring device which shall be accurate within  $\pm 1^{\circ}\text{C}$ ;
    - (ii) A wind speed measuring device which shall be accurate within  $\pm 1.0$  m/s.
2. Conditions of measurement
  - 2.1. Site
    - 2.1.1. The test site must consist of a central acceleration section surrounded by a substantially flat test area.

The acceleration section must be level; the track surface must be dry and such that rolling noise remains low.

The test track must be such that the conditions of a free sound field between the sound source and the microphone are attained to within 1 dB. This condition shall be deemed to be met if there are no large sound-reflecting objects such as fences, rocks, bridges or building within 50 m of the centre of the acceleration section. The surface of the site must be in accordance with the provisions given in Annex 8 to this Regulation and be free of powdery snow, tall grass, loose soil or cinders. There must be no obstacle which could affect the sound field within the vicinity of the microphone and the sound source. The observer carrying out the measurements must so position himself as not to affect the readings of the measuring instrument.

- 2.1.2. Measurements shall not be made under adverse weather conditions. It must be ensured that the results are not affected by gusts of wind.

Any sound peak which appears to be unrelated to the characteristics of the general sound level of the vehicle shall be ignored in taking the readings.

- 2.1.2.1. The meteorological instrumentation should be positioned adjacent to the test area at a height of  $1.2 \pm 0.1$  m.

The measurements shall be made when the ambient air temperature is within the range from 0° C to 40° C.

Tests shall not be carried out if the wind speed, including gusts, at microphone height exceeds 5 m/s, during the sound measurement interval and shall be recorded during each test run.

Values representative of temperature, wind speed and direction, relative humidity, and barometric pressure shall be recorded during the sound measurement interval.

- 2.1.3. The A-weighted sound level of sound sources other than those of the vehicle to be tested and of wind effects must be at least 10 dB(A) below the sound level produced by the vehicle.

## 2.2. Vehicle

- 2.2.1. Measurements shall be made on unladen vehicles and, except in the case of non-separable vehicles, without trailer or semi-trailer.

- 2.2.2. The tyres used for the test are selected by the vehicle manufacturer and shall comply with commercial practice and be available on the market; they shall correspond to one of the tyre sizes designated for the vehicle by the vehicle manufacturer and meet the minimum tread depth of 1.6 mm in the main grooves of the tread surface.

The tyres must be inflated to the pressure(s) appropriate to the test mass of the vehicle.

- 2.2.3. Before the measurements are started, the vehicle shall be brought to its normal operating conditions as regards:

- 2.2.3.1. Temperatures

- 2.2.3.2. Tuning

- 2.2.3.3. Fuel

- 2.2.3.4. Sparking plugs, carburettor(s), etc., (as appropriate).

- 2.2.4. If the vehicle is fitted with more than two-wheel drive, it shall be tested in the drive which is intended for normal road use.
- 2.2.5. If the vehicle is fitted with fan(s) having an automatic actuating mechanism, this system must not be interfered with during the measurements.
- 2.2.6. If the vehicle is equipped with an exhaust system containing fibrous materials, the exhaust system is to be conditioned before the test according to Annex 5.
3. Methods of testing
- 3.1. Measurement of noise of vehicles in motion
- 3.1.1. General conditions of test (see appendix, fig. 1)
- 3.1.1.1. At least two measurements shall be made on each side of the vehicle. Preliminary measurements may be made for adjustment purposes, but shall be disregarded.
- 3.1.1.2. The microphone must be located at a distance of  $7.5 \pm 0.2$  m from the reference line CC' (Figure 1) of the track and  $1.2 \pm 0.1$  m above the ground. Its axis of maximum sensitivity must be horizontal and perpendicular to the path of the vehicle (line CC').
- 3.1.1.3. Two lines, AA' and BB', parallel to line PP' and situated respectively 10 m forward and 10 m rearward of that line shall be marked out on the test runway.
- The vehicle shall be driven in a straight line over the acceleration section in such a way that the longitudinal median plane of the vehicle is as close as possible to the line CC' and approach line AA' at a steady speed as specified below. When the front of the vehicle reaches the line AA', the throttle shall be fully opened as rapidly as practicable and held in the fully-opened position until the rear of the vehicle crosses line BB'; the throttle shall then be closed again as rapidly as possible.
- 3.1.1.4. In the case of articulated vehicles consisting of two no separable units regarded as a single vehicle, the semi-trailer shall be disregarded in determining when line BB' is crossed.
- 3.1.1.5. The maximum sound level expressed in A-weighted decibels (dB(A)) shall be measured as the vehicle is driven between lines AA' and BB'. Such value shall constitute the result of the measurement.
- 3.1.2. Determination of the approach speed
- 3.1.2.1. Symbols used
- The letter symbols used in this paragraph have the following meaning:
- S: engine rotation speed as indicated under item 5.4. of Annex 1.
- $N_A$ : uniform engine rotational speed at the approach of line AA'.
- $V_A$ : uniform vehicle speed at the approach of line AA'.
- $V_{max}$ : maximum speed declared by the vehicle manufacturer.
- 3.1.2.2. Vehicle with no gearbox
- For vehicles with no gearbox or with no transmission control, the uniform speed at the approach of line AA' will be such that:
- either  $V_A = 50$  km/h;

or  $V_A$  corresponding to  $N_A = 3/4 S$  and  
 $V_A \leq 50$  km/h

In the case of vehicles of category  $M_1$  and in the case of vehicles of categories other than  $M_1$ , having an engine power not greater than 225 kW (ECE);

or  $V_A$  corresponding to  $N_A = 1/2 S$  and  
 $V_A \leq 50$  km/h

In the case of vehicles not belonging to category  $M_1$  having an engine power greater than 225 kW (ECE);

Or, in the case of vehicles powered by an electric motor

$$V_A = \frac{3}{4} V_{\max} \text{ or } V_A = 50 \text{ km/h,}$$

whichever is the lower.

3.1.2.3. Vehicle with a manually-operated gearbox

3.1.2.3.1. Approach speed

The vehicle shall approach the line AA' at a steady speed with a tolerance  $\pm 1$  km/h; except where the controlling factor is engine speed the tolerance shall be the larger of  $\pm 2$  per cent or  $\pm 50$  min-1, such that:

either  $V_A = 50$  km/h;

or  $V_A$  corresponding to  $N_A = 3/4 S$  and  
 $V_A \leq 50$  km/h

In the case of vehicles of category  $M_1$  and in the case of vehicles of categories other than  $M_1$ , having an engine power not greater than 225 kW (ECE);

or  $V_A$  corresponding to  $N_A = 1/2 S$  and  
 $V_A \leq 50$  km/h

In the case of vehicles not belonging to category  $M_1$  having an engine power greater than 225 kW (ECE);

Or, in the case of vehicles powered by an electric motor

$$V_A = \frac{3}{4} V_{\max} \text{ or } V_A = 50 \text{ km/h,}$$

whichever is the lower.

3.1.2.3.2. Choice of the gear ratio

3.1.2.3.2.1. Vehicles of categories  $M_1$  and  $N_1$ <sup>1</sup> fitted with a gearbox having four or less forward gears shall be tested in second gear.

3.1.2.3.2.2. Vehicles of categories  $M_1$  and  $N_1$ <sup>1</sup> fitted with a gearbox having more than four forward gears shall be tested successively in second and third gear. The average value of the sound levels recorded for these two conditions shall be calculated.

<sup>1</sup> As defined in annex 4 to this Regulation.

However, vehicles of category  $M_1$  having more than four forward gears and equipped with an engine developing a maximum power greater than 140 kW (ECE) and a permissible maximum-power/maximum-mass ratio greater than 75 kW (ECE)/t shall be tested only in third gear, provided that the speed at which the rear of the vehicle passes the line BB' in third gear is greater than 61 km/h.

If during the test in second gear, the engine speed exceeds the engine speed, S, at which the engine develops its rated maximum power, the test must be repeated with an approach speed and/or approach engine speed reduced by steps of 5 % S, until the engine speed attained no longer exceeds S.

If the engine speed S is still attained with an approach speed corresponding to the idle speed, then the test will be performed only in third gear and the relevant results have to be evaluated.

- 3.1.2.3.2.3. Vehicles of categories other than  $M_1$  and  $N_1$ , in which the total number of forward gear ratios is x (including those obtained by way of an auxiliary transmission or a multi-gear axle) will be tested sequentially, using the ratio equal to or higher than  $x/n$ .<sup>2,3</sup>.

Initial testing will be carried out using the ratio which is gear (x/n) or the next higher gear ratio if (x/n) is not an integer. The testing shall continue from the gear (x/n) to the next higher gear.

Shifting up gear ratios from (x/n) shall be terminating when in the gear X in which the rated engine speed is reached just before the rear of the vehicle has passed the line BB'.

Sample Calculation for Testing: There are 16 forward ratios for drive train having a transmission with 8 gears and an auxiliary transmission with 2 gears. If the engine has 230 kW then  $(x/n) = (8 \times 2)/3 = 16/3 = 5 \frac{1}{3}$ . The initial test gear ratio is 6th (includes the gears from both the main transmission and auxiliary which is 6th out of the 16 total gear ratios), with the next gear ratio is 7th up to ratio X.

In the case of vehicles having different overall gear ratios the representative of the vehicle type by the test vehicle is determined as follows:

If the highest sound level is obtained between the ratio x/n and ratio X the vehicle shall be deemed representative of its type;

If the highest sound level is obtained at ratio x/n the vehicle selected shall be deemed representative of its type only for those vehicles which have a lower overall gear ratio at x/n;

If the highest sound level is obtained at ratio X the vehicle selected shall be deemed representative of its type only for those vehicles which have a higher overall gear ratio than the gear ratio X.

However the vehicle is deemed representative of its type also, if at the applicant's request the tests are extended over more ratios than foreseen, and the highest sound level is obtained between the extreme ratios tested.

---

<sup>2</sup> Where: n = 2 for vehicles having an engine power not greater than 225 kW (ECE);  
n = 3 for vehicles having an engine power greater than 225 kW (ECE).

<sup>3</sup> If x/n does not correspond to a whole number, the nearest higher ratio must be used.

3.1.2.4. Automatic transmission<sup>4</sup>

3.1.2.4.1. Vehicles without a manual selector

3.1.2.4.1.1. Approach speed

The vehicle shall approach the line AA' at various uniform speeds of 30, 40, 50 km/h or at 3/4 of the maximum on-road speed if this value is lower.

If the vehicle is equipped with an automatic transmission which cannot be tested with the procedure outlined in the subsequent sections, it shall be tested at different approach speeds, namely 30 km/h, 40 km/h, and 50 km/h, or at three quarters of maximum vehicle speed as specified by the manufacturer if this value is lower. The condition giving the highest noise level shall be retained.

3.1.2.4.2. Vehicles equipped with a manual selector with X positions

3.1.2.4.2.1. Approach speed

The vehicle shall approach the line AA' at a steady speed corresponding to the lower of the following velocities with a tolerance  $\pm 1$  km/h; except where the controlling factor is engine speed the tolerance shall be the larger of  $\pm 2$  per cent or  $\pm 50$  rpm, such that:

either  $V_A = 50$  km/h;

or  $V_A$  corresponding to  $N_A = 3/4$  S and  
 $V_A \leq 50$  km/h

In the case of vehicles of category  $M_1$  and in the case of vehicles of categories other than  $M_1$ , having an engine power not greater than 225 kW (ECE);

or  $V_A$  corresponding to  $N_A = 1/2$  S and  
 $V_A \leq 50$  km/h

In the case of vehicles not belonging to category  $M_1$  having an engine power greater than 225 kW (ECE);

or, in the case of vehicles powered by an electric motor

$$V_A = \frac{3}{4} V_{\max} \text{ or } V_A = 50 \text{ km/h,}$$

whichever is the lower.

However, if during the test, in the case of vehicles having more than two separate gears, there is an automatic down-shift to first gear, this down-shift may be avoided, at the manufacturer's choice, according to paragraph 3.1.2.4.2.4.

3.1.2.4.2.2. Position of the manual selector

The test shall be conducted with the selector in the position recommended by the manufacturer for "normal" driving. External downshifting (for example kick down) shall be excluded.

3.1.2.4.2.3. Auxiliary gears

<sup>4</sup> All vehicles equipped with automatic transmission.

If the vehicle is fitted with an auxiliary manual transmission or a multi-gear axle, the position used for normal urban driving shall be used. In all cases, the special selector's positions for slow movements, parking, or braking shall be excluded.

3.1.2.4.2.4. Prevention of downshift

Some vehicles equipped with an automatic transmission (two or more discrete ratios) may downshift to a gear ratio not normally used in urban driving, as defined by the manufacturer. A gear ratio not used for urban driving includes a gear ratio intended for slow movement, parking or braking. In these cases the operator may select any of the following modifications:

- (a) Increase the vehicle speed  $v$  to a maximum of 60 km/h in order to avoid such a change down;
- (b) Maintain the vehicle speed  $v$  at 50 km/h and limit the fuel supply to the engine to 95 per cent of the supply necessary for full load; this condition is considered to be satisfied;
  - (i) In the case of a spark-ignition engine, when the angle of the throttle opening is 90 per cent of the full angle,
  - (ii) In the case of a compression-ignition engine, when the fuel supply to the injection pump is limited to 90 per cent of its maximum supply;
- (c) Establish and use an electronic control that will prevent a downshift to gears lower than those used in normal urban driving as defined by the manufacturer.

3.1.3. Interpretation of results

The measurements of noise emitted by the vehicle in motion shall be considered valid if the difference between the two consecutive measurements on the same side of the vehicle is not more than 2 dB(A)<sup>5</sup>.

The figure recorded shall be that corresponding to the highest sound level. Should that figure exceed by more than 1 dB(A) the maximum sound level authorized for the category of vehicle tested, a second series of two measurements at the corresponding microphone position shall be made. Three out of the four results so obtained in this position must fall within the prescribed limits.

To allow for lack of precision in the measuring instrument the figures read from it during measurement shall each be reduced by 1 dB(A).

3.2. Measurement of noise emitted by stationary vehicles

3.2.1. Sound level in the vicinity of vehicles

In order to facilitate subsequent checks on vehicles in use, the sound level must be measured close to the exhaust system outlet in accordance with the following requirements and the measurement results entered in the test report drawn up for the purpose of issuing the certificate referred to in Annex 1.

---

<sup>5</sup> The spread of results between runs may be reduced if there is a 1 min. wait between runs, at idle in neutral, which stabilizes the vehicle operating temperature.



- 3.2.2. Acoustic measurements
- A precision sound level meter as defined in paragraph 1.1. of this annex must be used for the measurements.
- 3.2.3. Test site - local conditions (see appendix, figure 2 and 3a to 3d)
- 3.2.3.1. Measurements should be made on a stationary vehicle in an area which corresponds to that for measurements of vehicles in motion and therefore corresponds to the provisions given in Annex 8 to this Regulation.
- 3.2.3.2. During the test nobody shall be in the measurement area, except the observer and the driver whose presence must have no influence on the meter reading.
- 3.2.4. Disturbance noise and wind interference
- Readings on the measuring instruments produced by ambient noise and wind must be at least 10 dB(A) below the sound level to be measured. A suitable windscreen may be fitted to the microphone provided that account is taken of its effect on the sensitivity of the microphone.
- 3.2.5. Measuring method
- 3.2.5.1. Nature and number of measurements
- The maximum sound level expressed in A-weighted decibels (dB(A)) must be measured during the operating period referred to in paragraph 3.2.5.3.2.1.
- At least three measurements must be taken at each measuring point.
- 3.2.5.2. Positioning and preparation of the vehicle
- The vehicle shall be located in the centre part of the test area with the gear level in neutral position and the clutch engaged. If the design of the vehicle does not allow this, the vehicle shall be tested in conformity with the manufacturer's prescriptions for stationary engine testing. Before each series of measurements, the engine must be brought to its normal operating condition, as specified by the manufacturer.
- If the vehicle is fitted with fan(s) having an automatic actuating mechanism, this system shall not be interfered with during the sound level measurements.
- 3.2.5.3. Measuring of noise in proximity to the exhaust
- (see appendix, fig. 2)
- 3.2.5.3.1. Microphone orientation
- 3.2.5.3.1.1. The microphone shall be located at a distance of  $0.5 \text{ m} \pm 0.01 \text{ m}$  from the reference point of the exhaust pipe defined in Figure 2 and at an angle of  $45^\circ$  ( $\pm 5^\circ$ ) to the vertical plane containing the flow axis of the pipe termination. The microphone shall be at the height of the reference point, but not less than 0.2 m from the ground surface. The reference axis of the microphone shall lie in a plane parallel to the ground surface and shall be directed towards the reference point on the exhaust outlet.
- If two microphone positions are possible, the location farthest laterally from the vehicle longitudinal centreline shall be used.
- If the flow axis of the exhaust outlet pipe is at  $90^\circ$  to the vehicle longitudinal centreline, the microphone shall be located at the point, which is furthest from the engine.

- 3.2.5.3.1.2. For vehicles having an exhaust provided with outlets spaced more than 0.3 m apart, one measurement is made for each outlet as if it were the only one, and the highest sound pressure level shall be noted.
- 3.2.5.3.1.3. If a vehicle has two or more exhaust outlets spaced less than 0.3 m apart and connected to a single silencer, only one measurement shall be made. The microphone shall be located relative to the outlet farthest from the vehicle longitudinal centreline, or when such outlet does not exist, to the outlet, which is highest above the ground.
- 3.2.5.3.1.4. For vehicles with a vertical exhaust (e.g. commercial vehicles) the microphone shall be placed at the height of the exhaust outlet. Its axis shall be vertical and oriented upwards. It shall be placed at a distance of 0.5 m  $\pm$  0.01 m from the exhaust pipe reference point as defined in Figure 2, but never less than 0.2 m from the side of the vehicle nearest to the exhaust.
- 3.2.5.3.1.5. For vehicles, where the reference point of the exhaust pipe is not accessible, or located under the vehicle body, as shown in Figures 3b and 3c, because of the presence of obstacles which form part of the vehicle (e.g. spare wheel, fuel tank, battery compartment), the microphone shall be located at least 0.2 m from the nearest obstacle, including the vehicle body, and its axis of maximum sensitivity shall face the exhaust outlet from the position least concealed by the above mentioned obstacles.

When several positions are possible, as shown in Figure 3c, the microphone position giving the lowest value of d1 or d2 shall be used.

*Note:* Figures 3a to 3d show examples of the position of the microphone, depending on the location of the exhaust pipe.

- 3.2.5.3.2. Operating conditions of the engine

- 3.2.5.3.2.1. Target engine speed

The target engine speed is defined as:

- (a) 75 per cent of the engine speed S for vehicles with a rated engine speed  $\leq 5,000 \text{ min}^{-1}$ ;
- (b)  $3,750 \text{ min}^{-1}$  for vehicles with a rated engine speed above  $5,000 \text{ min}^{-1}$  and below  $7,500 \text{ min}^{-1}$ ;
- (c) 50 per cent of the engine speed S for vehicles with a rated engine speed  $\geq 7,500 \text{ min}^{-1}$ .

If the vehicle cannot reach the engine speed as stated above, the target engine speed shall be 5 per cent below the maximum possible engine speed for that stationary test.

- 3.2.5.3.2.2. Test procedure

The engine speed shall be gradually increased from idle to the target engine speed, not exceeding the tolerance band of  $\pm 5$  per cent of the target engine speed, and held constant. Then the throttle control shall be rapidly released and the engine speed shall be returned to idle. The sound pressure level shall be measured during a period consisting of constant engine speed of at least one second and throughout the entire deceleration period. The maximum sound level meter reading shall be taken as the test value.

3.2.5.3.2.3. Test validation

The measurement shall be regarded as valid if the test engine speed does not deviate from the target engine speed by more than  $\pm 5$  per cent for at least one second.

3.2.6. Results

3.2.6.1. Measurements shall be made according to the microphone location(s) described in paragraph 3.2.5.3.1.

3.2.6.2. The maximum A-weighted sound pressure level indicated during the test shall be noted, mathematically rounded to the first significant figure before the decimal place.

3.2.6.3. The test shall be repeated until three consecutive measurements at each outlet are obtained, which are within 2 dB of each other, allowing for deletion of non valid results.

3.2.6.4. The result for a given outlet is the arithmetic average of the three valid measurements, mathematically rounded as given above and shall be reported as the A-weighted sound pressure level  $L_{Arep}$ .

3.2.6.5. For vehicles equipped with multiple gas outlets, the sound pressure level reported  $L_{Arep}$  shall be for the outlet having the highest average sound pressure level.

## Annex 3 - Appendix

### Measuring positions for vehicles in motion

Figure 1  
Measuring positions for stationary vehicles  
(examples)

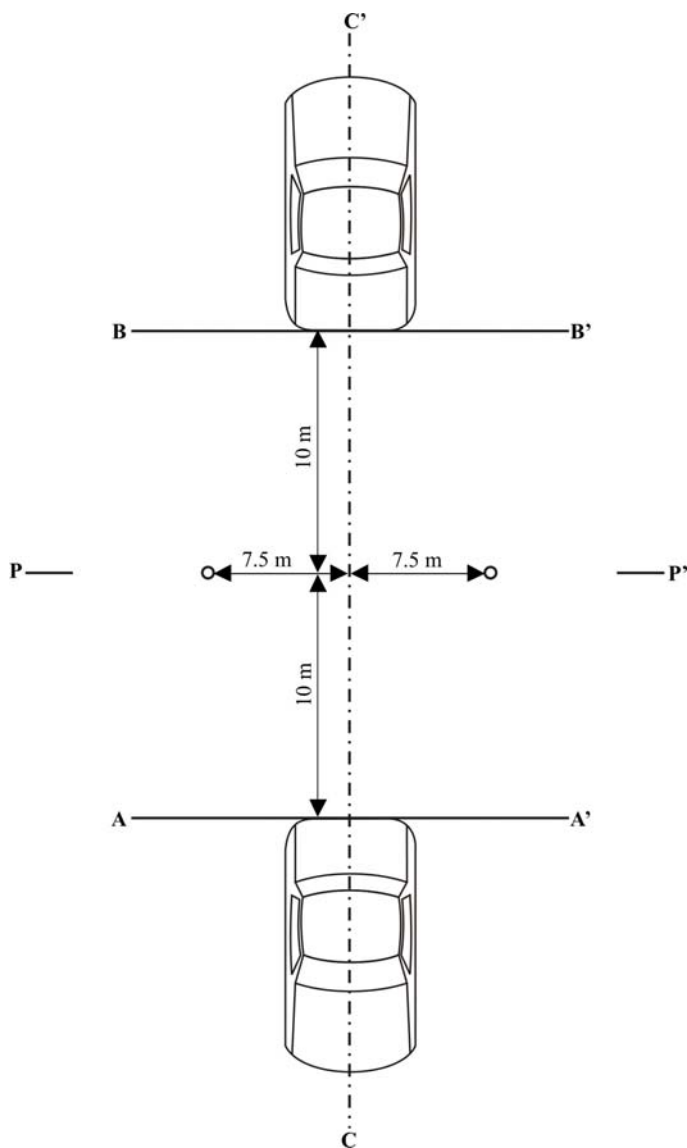

Figure 2  
 Reference point

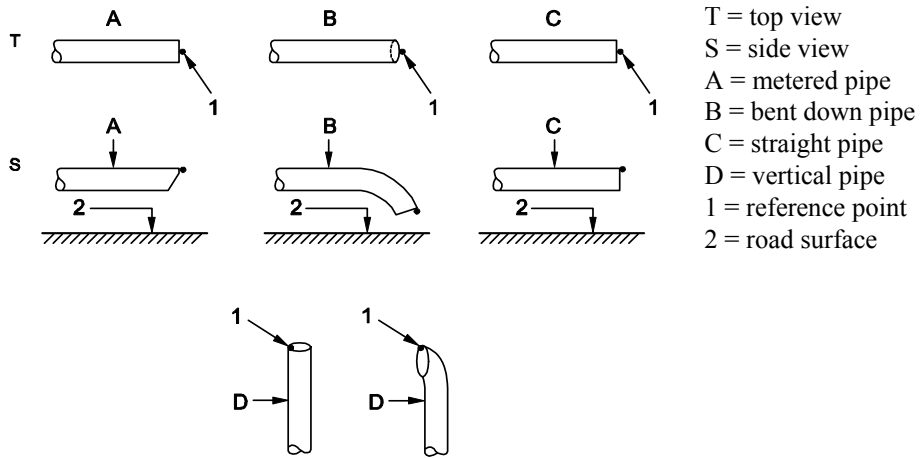

Figure 3a

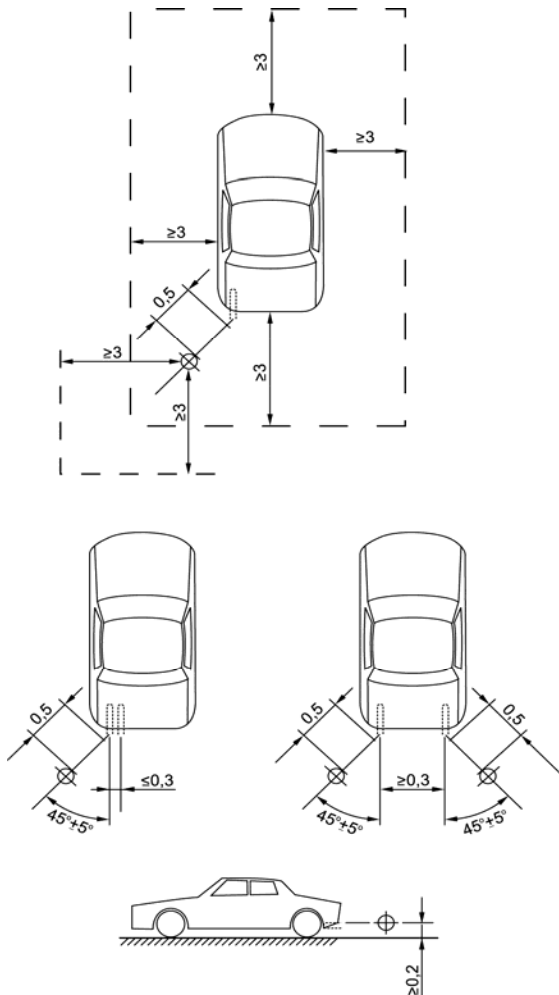

Figure 3b

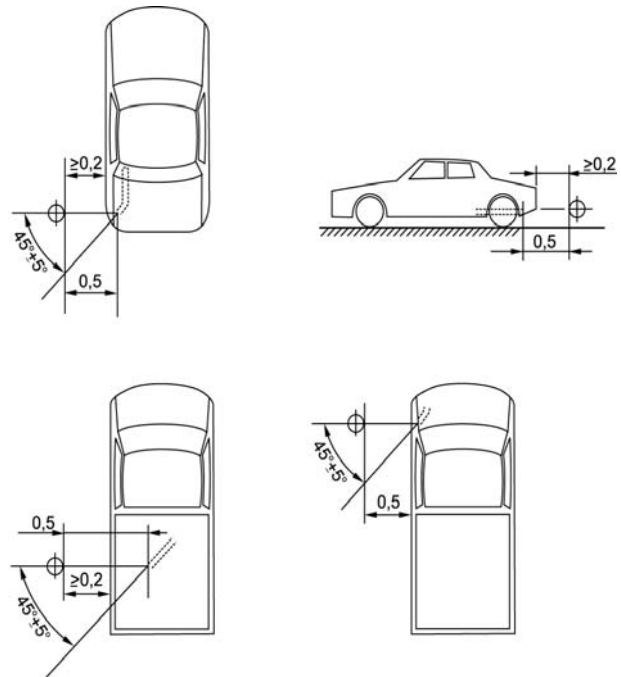

Figure 3c

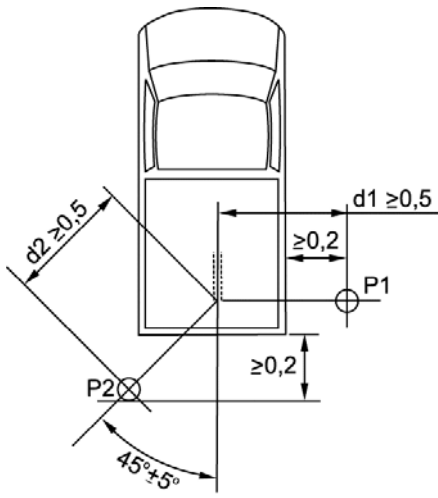
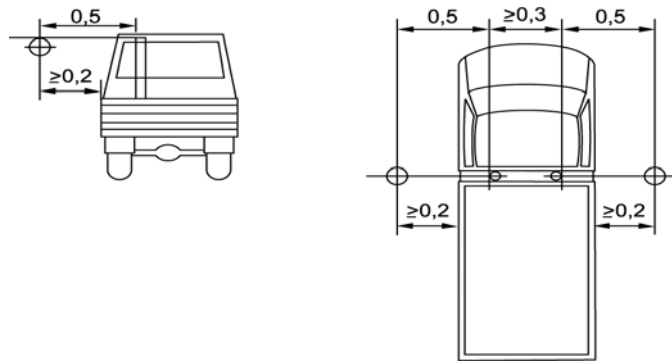

Figure 3d



## Annex 4

### Classification of vehicles<sup>1</sup>

1. Category L  
(Not applicable for this Regulation)
2. Category M - Power-driven vehicles having at least four wheels and used for the carriage of passengers
  - 2.1. Category M<sub>1</sub>: Vehicles used for the carriage of passengers and comprising not more than eight seats in addition to the driver's seat.
  - 2.2. Category M<sub>2</sub>: Vehicles used for the carriage of passengers, comprising more than eight seats in addition to the driver's seat, and having a maximum mass not exceeding 5 tonnes.
  - 2.3. Category M<sub>3</sub>: Vehicles used for the carriage of passengers, comprising more than eight seats in addition to the driver's seat, and having a maximum mass exceeding 5 tonnes.
  - 2.4. Vehicles of categories M<sub>2</sub> and M<sub>3</sub> belong to one of the three following classes:
    - 2.4.1. Class I "*city-bus*": a vehicle of this class has seats, and spaces for standing passengers.
    - 2.4.2. Class II "*interurban bus or coach*": a vehicle of this class may have provision for standing passengers, but only in the gangway.
    - 2.4.3. Class III "*touring coach*": a vehicle of this class has no provisions to carry standing passengers.
  - 2.5. Remarks
    - 2.5.1. "*Articulated bus or coach*" is a vehicle which consists of two or more rigid sections which articulate relative to one another; the passenger compartments of each section intercommunicate so that passengers can move freely between them; the rigid sections are permanently connected so that they can only be separated by an operation involving facilities which are normally only found in a workshop.
    - 2.5.2. Articulated buses or coaches comprising two or more non-separable but articulated units shall be considered as single vehicles.
    - 2.5.3. In the case of a towing vehicle designed to be coupled to a semitrailer (tractor for semi-trailer), the mass to be considered for classifying the vehicle is the mass of the tractor vehicle in running trim, increased by the mass corresponding to the maximum static vertical load transferred to the tractor vehicle by the semi-trailer and, where applicable, by the maximum mass of the tractor vehicle's own load.

---

<sup>1</sup> In conformity with the Consolidated Resolution on the Construction of Vehicles (R.E.3) (TRANS/SC1/WP29/78/Amend.3, annex 7).

- 3. Category N - Power-driven vehicles having at least four wheels and used for the carriage of goods.
- 3.1. Category N<sub>1</sub>: Vehicles used for the carriage of goods and having a maximum mass not exceeding 3.5 tonnes.
- 3.2. Category N<sub>2</sub>: Vehicles used for the carriage of goods and having a maximum mass exceeding 3.5 tonnes but not exceeding 12 tonnes.
- 3.3. Category N<sub>3</sub>: Vehicles used for the carriage of goods and having a maximum mass exceeding 12 tonnes.
- 3.4. Remarks
  - 3.4.1. In the case of a towing vehicle designed to be coupled to a semitrailer (tractor for semi-trailer), the mass to be considered for classifying the vehicle is the mass of the tractor vehicle in running trim, increased by the mass corresponding to the maximum static vertical load transferred to the tractor vehicle by the semi-trailer and, where applicable, by the maximum mass of the tractor vehicle's own load.
  - 3.4.2. The equipment and installations carried on certain special purpose vehicles (crane vehicles, workshop vehicles, publicity vehicles, etc.) are regarded as being equivalent to goods.



## Annex 5

### Silencing systems containing acoustically absorbing fibrous materials

#### 1. General

Sound absorbing fibrous materials may be used in silencing systems or components thereof only if

- (a) The exhaust gas is not in contact with the fibrous materials; or if
- (b) The silencing system or components thereof are of the same design family as systems or components for which it has been proven, in the course of type approval process in accordance with the requirements of this regulation for another vehicle-type, that they are not subject to deterioration.

Unless one of these conditions is fulfilled, the complete silencing system or components thereof shall be submitted to a conventional conditioning using one of three installations and procedures described below.

#### 1.1. Continuous road operation for 10,000 km

1.1.1. 50 ± 20 per cent of this operation shall consist of urban driving and the remaining operation shall be long-distance runs at high speed; continuous road operation may be replaced by a corresponding test-track programme.

1.1.2. The two speed regimes shall be alternated at least twice.

1.1.3. The complete test program shall include a minimum of 10 breaks of at least three hours duration in order to reproduce the effects of cooling and any condensation which may occur.

#### 1.2. Conditioning on a test bench

1.2.1. Using standard parts and observing the vehicle manufacturer's instructions, the silencing system or components thereof shall be fitted to the vehicle referred to in paragraph 3.3. of this Regulation or the engine referred to in paragraph 3.4. of this Regulation. In the former case the vehicle shall be mounted on a roller dynamometer. In the second case, the engine shall be coupled to a dynamometer.

1.2.2. The test shall be conducted in six six-hour periods with a break of at least 12 hours between each period in order to reproduce the effects of cooling any condensation which may occur.

1.2.3. During each six-hour period, the engine shall be run, under the following conditions:

- (a) Five minutes at idling speed;
- (b) One-hour sequence under 1/4 load at 3/4 of rated maximum speed (S);
- (c) One-hour sequence under 1/2 load at 3/4 of rated maximum speed (S);
- (d) 10-minute sequence under full load at 3/4 of rated maximum speed (S);
- (e) 15-minute sequence under 1/2 load at rated maximum speed (S);
- (f) 30-minute sequence under 1/4 load at rated maximum speed (S).

Each period shall comprise two sequenced sets of the six above-mentioned conditions in consecutive order from (a) to (f).

- 1.2.4. During the test, the silencing system or components thereof shall not be cooled by a forced draught simulating normal airflow around the vehicle. Nevertheless, at the request of the manufacturer, the silencing system or components thereof may be cooled in order not to exceed the temperature recorded at its inlet when the vehicle is running at maximum speed.
- 1.3. Conditioning by pulsation
- 1.3.1. The silencing system or components thereof shall be fitted to the vehicle referred to in paragraph 3.3. of this Regulation or the engine referred to in paragraph 3.4. of this Regulation. In the former case the vehicle shall be mounted on a roller dynamometer.
- In the second case, the engine shall be mounted on a dynamometer. The test apparatus, a detailed diagram of which is shown in Figure 3 of the appendix to this annex shall be fitted at the outlet of the silencing system. Any other apparatus providing equivalent results is acceptable.
- 1.3.2. The test apparatus shall be adjusted in such a way that the exhaust-gas flow is alternatively interrupted and re-established by the quick-action valve for 2,500 cycles.
- 1.3.3. The valve shall open when the exhaust-gas back pressure, measured at least 100 mm downstream of the intake flange, reaches a value of between 35 and 40 kPa. It shall close when this pressure does not differ by more than 10 per cent from its stabilized value with the valve open.
- 1.3.4. The time-delay switch shall be set for the duration of gas exhaust resulting from the provisions laid down in paragraph 1.3.3. above.
- 1.3.5. Engine speed shall be 75 per cent of the speed (S) at which the engine develops maximum power.
- 1.3.6. The power indicated by the dynamometer shall be 50 per cent of the full-throttle power measured at 75 per cent of engine speed (S).
- 1.3.7. Any drain holes shall be closed off during the test.
- 1.3.8. The entire test shall be completed within 48 hours.
- If necessary, one cooling period will be observed after each hour.

## Annex 5 - Appendix

Figure 3  
 Test apparatus for conditioning by pulsation

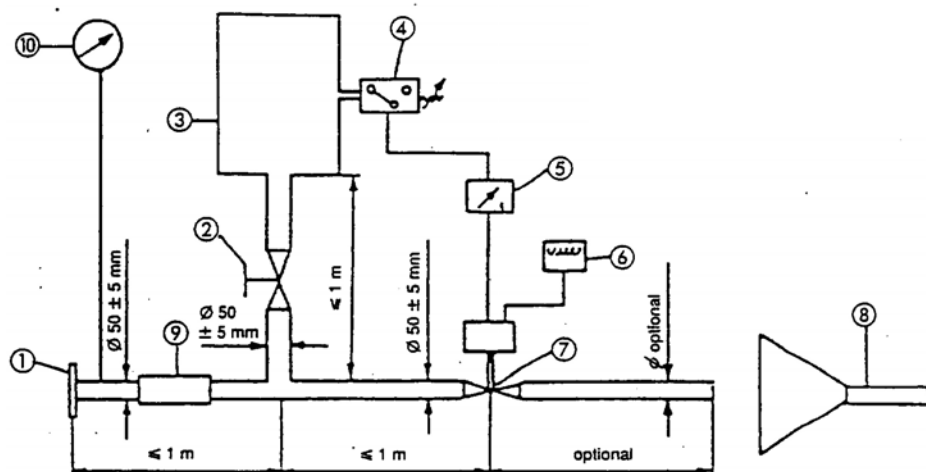

1. Inlet flange or sleeve for connection to the rear of the test exhaust system.
2. Hand-operated regulating valve.
3. Compensating reservoir with a maximum capacity of 40 l and a filling time of not less than one second.
4. Pressure switch with an operating range of 0.05 to 2.5 bar.
5. Time delay switch.
6. Pulse counter.
7. Quick-acting valve, such as exhaust brake valve 60 mm in diameter, operated by a pneumatic cylinder with an output of 120 N at 4 bar. The response time, both when opening and closing, must not exceed 0.5 second.
8. Exhaust gas evacuation.
9. Flexible pipe.
10. Pressure gauge.

## Annex 6

### Compressed air noise

1. Method of measurement

The measurement is performed at microphone positions 2 and 6 according to Figure 1, with the vehicle stationary. The highest A-weighted noise level is registered during venting the pressure regulator and during ventilating after the use of both the service and parking brakes.

The noise during venting the pressure regulator is measured with the engine at idling speed. The ventilating noise is registered while operating the service and parking brakes; before each measurement, the air-compressor unit has to be brought up to the highest permissible operating pressure, and then the engine switched off.

2. Evaluation of the results

For all microphone positions two measurements are taken. In order to compensate for inaccuracies of the measuring equipment, the metre reading is reduced by 1 dB(A), and the reduced value is taken as the result of measurement. The results are taken as valid if the difference between the measurements at one microphone position does not exceed 2 dB(A). The highest value measured is taken as the result. If this value exceeds the noise limit by 1 dB(A), two additional measurements are to be taken at the corresponding microphone position.

In this case, three out of the four results of measurement obtained at this position have to comply with the noise limit.

3. Limiting value

The sound level shall not exceed the limit of 72 dB(A).

## Annex 6 - Appendix

Figure 1:  
Microphone positions for measurement of compressed air noise

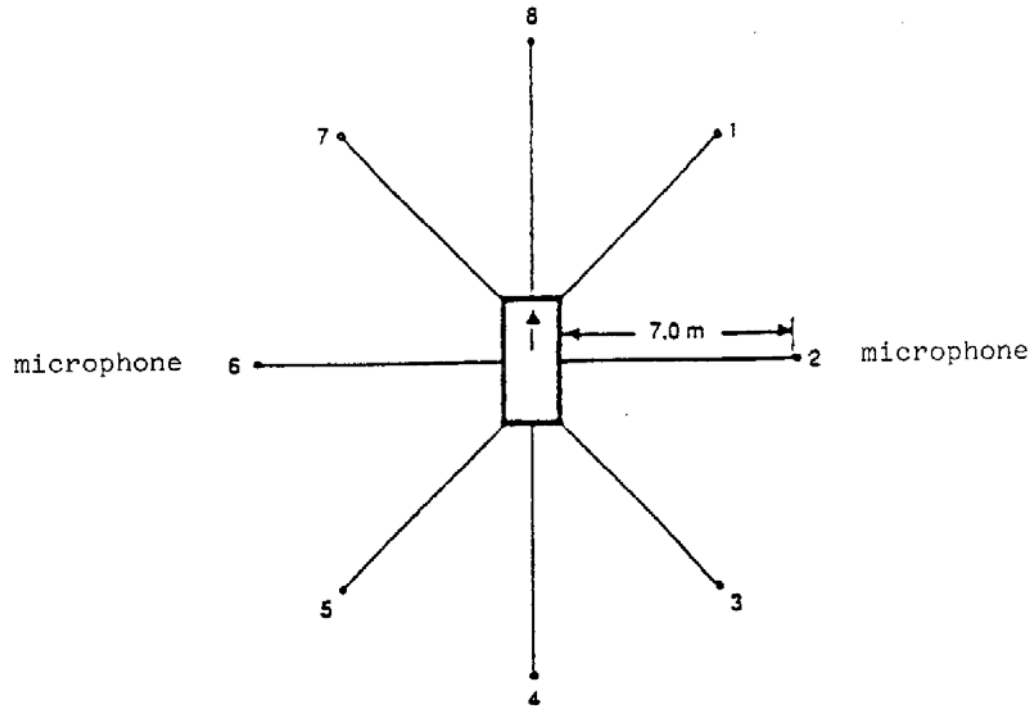

The measurement is performed at the stationary vehicle according to Figure 1, using two microphone positions at a distance of 7 m from the contour of the vehicles, and at 1.2 m above ground.

## Annex 7

### Checks on conformity of production

1. General

These requirements are consistent with the test to be held to check conformity of production according to paragraphs 8.3.5. and 8.4.3. of this Regulation.
2. Testing procedure

The test site and measuring instruments shall be those as described in Annex 3.
- 2.1. The vehicle(s) under test shall be subjected to the test for measurement of noise of vehicle in motion as described in paragraph 3.1. of Annex 3.
- 2.2. Compressed air noise

Vehicles having maximum mass exceeding 2,800 kg and equipped with compressed air systems must be subjected to an additional test for measurement of the compressed air noise as described in paragraph 1 of Annex 6.
3. Sampling

One vehicle has to be chosen. If after the test of paragraph 4.1. the vehicle is not considered to conform to the requirements of this Regulation, two more vehicles have to be tested.
4. Evaluation of the results
- 4.1. If the sound level of the vehicle tested pursuant to paragraphs 1 and 2 does not exceed by more than 1 dB(A) the limit value prescribed in paragraph 6.2.2. of this Regulation, for measurement according to paragraph 2.1. above, and in paragraph 3 of Annex 6 to this Regulation, for measurement according to paragraph 2.2. above, the vehicle type shall be considered to conform to the requirements of this Regulation.
- 4.2. If the vehicle tested according to paragraph 4.1. does not satisfy the requirements laid down in that paragraph, two more vehicles of the same type have to be tested pursuant to paragraphs 1 and 2.
- 4.3. If the sound level of the second and/or third vehicle of paragraph 4.2. exceeds by more than 1 dB(A) the limit values prescribed in paragraph 6.2.2. of this Regulation, the vehicle type shall be considered not to conform to the requirements of this Regulation and the manufacturer shall take the necessary measures to re-establish the conformity.

## Annex 8

### Specifications for the test site

#### 1. Introduction

This annex describes the specifications relating to the physical characteristics and the laying of the test track. These specifications based on a special standard<sup>1</sup> describe the required physical characteristics as well as the test methods for these characteristics.

#### 2. Required characteristics of the surface

A surface is considered to conform to this standard provided that the texture and voids content or sound absorption coefficient have been measured and found to fulfil all the requirements of paragraphs 2.1. to 2.4. below and provided that the design requirements (para. 3.2.) have been met.

##### 2.1. Residual voids content

The residual voids content, VC, of the test track paving mixture shall not exceed 8%. For the measurement procedure, see paragraph 4.1.

##### 2.2. Sound absorption coefficient

If the surface fails to comply with the residual voids content requirement, the surface is acceptable only if its sound absorption coefficient,  $\alpha \leq 0.10$ . For the measurement procedure, see para. 4.2. The requirement of paragraphs 2.1. and 2.2. is met also if only sound absorption has been measured and found to be  $\alpha \leq 0.10$ .

*Note:* The most relevant characteristic is the sound absorption, although the residual voids content is more familiar among road constructors. However, sound absorption needs to be measured only if the surface fails to comply with the voids requirement. This is motivated because the latter is connected with relatively large uncertainties in terms of both measurements and relevance and some surfaces therefore erroneously may be rejected when based only on the voids measurement.

##### 2.3. Texture depth

The texture depth (TD) measured according to the volumetric method (see paragraph 4.3. below) shall be:

$$TD \geq 0.4 \text{ mm}$$

##### 2.4. Homogeneity of the surface

Every practical effort shall be taken to ensure that the surface is made to be as homogeneous as possible within the test area. This includes the texture and voids content, but it should also be observed that if the rolling process results in more effective rolling at some places than others, the texture may be different and unevenness causing bumps may also occur.

---

<sup>1</sup> ISO 10844:1994.

2.5. Period of testing

In order to check whether the surface continues to conform to the texture and voids content or sound absorption requirements stipulated in this standard, periodic testing of the surface shall be done at the following intervals:

(a) For residual voids content or sound absorption:

When the surface is new;

If the surface meets the requirements when new, no further periodical testing is required. If it does not meet the requirement when it is new, it may do later because surfaces tend to become clogged and compacted with time.

(b) For texture depth (TD):

When the surface is new;

When the noise testing starts (NB: not before four weeks after laying);

Then every twelve months.

3. Test surface design

3.1. Area

When designing the test track layout it is important to ensure that, as a minimum requirement, the area traversed by the vehicles running through the test strip is covered with the specified test material with suitable margins for safe and practical driving. This will require that the width of the track is at least 3 m and the length of the track extends beyond lines AA and BB by at least 10 m at either end. Figure 1 shows a plan of a suitable test site and indicates the minimum area which shall be machine laid and machine compacted with the specified test surface material. According to Annex 3, paragraph 3.1.1.1., measurements have to be made on each side of the vehicle. This can be made either by measuring with two microphone locations (one on each side of the track) and driving in one direction, or measuring with a microphone only on one side of the track but driving the vehicle in two directions. If the latter method is used, then there are no surface requirements on that side of the track where there is no microphone.



Figure 1:  
**Minimum requirement for test surface area. The shaded part is called "Test Area".**

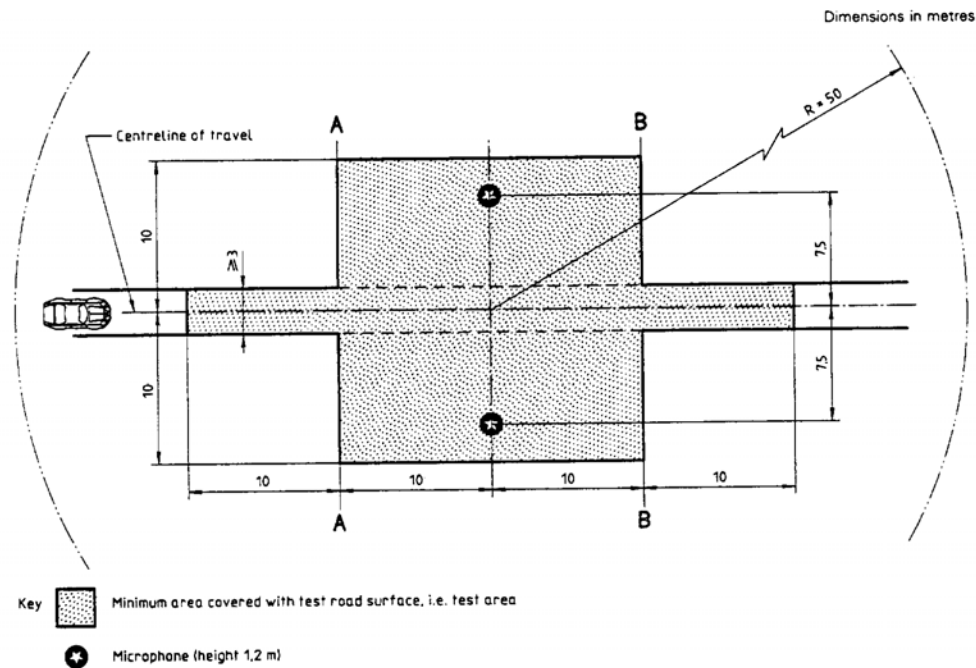

NOTE — There shall be no large acoustically reflective objects within this radius.

### 3.2. Design and preparation of the surface

#### 3.2.1. Basic design requirements

The test surface shall meet four design requirements:

3.2.1.1. It shall be a dense asphaltic concrete.

3.2.1.2. The maximum chipping size shall be 8 mm (tolerances allow from 6.3 to 10 mm).

3.2.1.3. The thickness of the wearing course shall be  $\geq 30$  mm.

3.2.1.4. The binder shall be a straight penetration grade bitumen without modification.

#### 3.2.2. Design guidelines

As a guide to the surface constructor, an aggregate grading curve which will give desired characteristics is shown in Figure 2. In addition, Table 1 gives some guidelines in order to obtain the desired texture and durability. The grading curve fits the following formula:

$$P (\% \text{ passing}) = 100 \cdot (d/d_{\max})^{1/2}$$

where:

d = square mesh sieve size, in mm

$d_{\max}$  = 8 mm for the mean curve

$d_{\max}$  = 10 mm for the lower tolerance curve

$d_{\max}$  = 6.3 mm for the upper tolerance curve

Figure 2:  
**Grading curve of the aggregate in the asphaltic mix with tolerances.**

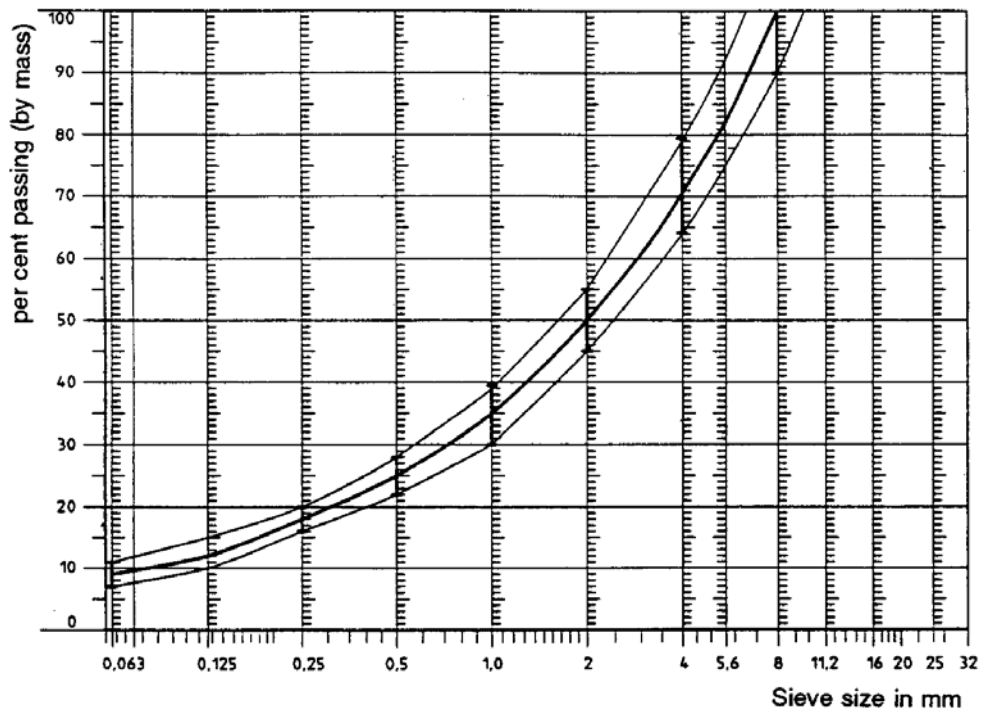

In addition to the above, the following recommendations are given:

- (a) The sand fraction (0.063 mm < square mesh sieve size < 2 mm) shall include no more than 55% natural sand and at least 45% crushed sand;
- (b) The base and sub-base shall ensure a good stability and evenness, according to best road construction practice;
- (c) The chippings shall be crushed (100% crushed faces) and of a material with a high resistance to crushing;
- (d) The chippings used in the mix shall be washed;
- (e) No extra chippings shall be added onto the surface;
- (f) The binder hardness expressed as PEN value shall be 40-60, 60-80 or even 80-100 depending on the climatic conditions of the country. The rule is that as hard a binder as possible shall be used, provided this is consistent with common practice;
- (g) The temperature of the mix before rolling shall be chosen so as to achieve by subsequent rolling the required voids content. In order to increase the probability of satisfying the specifications of paragraphs 2.1. to 2.4. above, the compactness shall be studied not only by an appropriate choice of mixing temperature, but also by an appropriate number of passings and by the choice of compacting vehicle.

Table 1:  
**Design guidelines**

	<i>Target values</i>		<i>Tolerances</i>
	<i>By total mass of mix</i>	<i>By mass of the aggregate</i>	
Mass of stones, square mesh sieve (SM) > 2 mm	47.6 %	50.5 %	±5
Mass of sand 0.063 < SM < 2 mm	38.0 %	40.2 %	±5
Mass of filler SM < 0.063 mm	8.8 %	9.3 %	±2
Mass of binder (bitumen)	5.8 %	N.A.	±0.5
Max. chipping size	8 mm		±6.3 - 10
Binder hardness	(see para. 3.2.2. (f))		
Polished stone value (PSV)	>50		
Compactness, relative to Marshall compactness	98 %		

4. Test method

4.1. Measurement of the residual voids content

For the purpose of this measurement, cores have to be taken from the track in at least four different positions which are equally distributed in the test area between lines AA and BB (see figure 1). In order to avoid inhomogeneity and unevenness in the wheel tracks, cores should not be taken in wheel tracks themselves, but close to them. Two cores (minimum) should be taken close to the wheel tracks and one core (minimum) should be taken approximately midway between the wheel tracks and each microphone location.

If there is a suspicion that the condition of homogeneity is not met (see paragraph 2.4.), cores shall be taken from more locations within the test area.

The residual voids content has to be determined for each core, then the average value from all cores shall be calculated and compared with the requirement of paragraph 2.1. In addition, no single core shall have a voids value which is higher than 10%. The test surface constructor is reminded of the problem which may arise when the test area is heated by pipes or electrical wires and cores must be taken from this area. Such installations must be carefully planned with respect to future core drilling locations. It is recommended to leave a few locations of size approximately 200 x 300 mm where there are no wires/pipes or where the latter are located deep enough in order not to be damaged by cores taken from the surface layer.

4.2. Sound absorption coefficient

The sound absorption coefficient (normal incidence) shall be measured by the impedance tube method using the procedure specified in ISO 10534-1: "Acoustics - Determination of sound absorption coefficient and impedance by a tube method"<sup>2</sup>.

<sup>2</sup> To be published

Regarding test specimens, the same requirements shall be followed as regarding the residual voids content (see paragraph 4.1.). The sound absorption shall be measured in the range between 400 Hz and 800 Hz and in the range between 800 Hz and 1,600 Hz (at least at the centre frequencies of third octave bands) and the maximum values shall be identified for both of these frequency ranges. Then these values, for all test cores, shall be averaged to constitute the final result.

4.3. Volumetric macrotexture measurement

For the purpose of this standard, texture depth measurements shall be made on at least 10 positions evenly spaced along the wheel tracks of the test strip and the average value taken to compare with the specified minimum texture depth. See ISO 10844:1994 for the description of the procedure.

5. Stability in time and maintenance

5.1. Age influence

In common with any other surfaces, it is expected that the tyre/road noise level measured on the test surface may increase slightly during the first 6-12 months after construction.

The surface will achieve its required characteristics not earlier than four weeks after construction. The influence of age on the noise from trucks is generally less than that from cars.

The stability over time is determined mainly by the polishing and compaction by vehicles driving on the surface. It shall be periodically checked as stated in paragraph 2.5.

5.2. Maintenance of the surface

Loose debris or dust which could significantly reduce the effective texture depth must be removed from the surface. In countries with winter climates, salt is sometimes used for deicing. Salt may alter the surface temporarily or even permanently in such a way as to increase noise and is therefore not recommended.

5.3. Repaving the test area

If it is necessary to repave the test track, it is usually unnecessary to repave more than the test strip (of 3 m width in figure 1) where vehicles are driving, provided the test area outside the strip met the requirement of residual voids content or sound absorption when it was measured.

6. Documentation of the test surface and of tests performed on it

6.1. Documentation of the test surface

The following data shall be given in a document describing the test surface:

6.1.1. The location of the test track.

6.1.2. Type of binder, binder hardness, type of aggregate, maximum theoretical density of the concrete (DR), thickness of the wearing course and grading curve determined from cores from the test track.

6.1.3. Method of compaction (e.g. type of roller, roller mass, number of passes).

6.1.4. Temperature of the mix, temperature of the ambient air and wind speed during laying of the surface.

- 6.1.5. Date when the surface was laid and contractor.
- 6.1.6. All or at least the latest test result, including:
  - 6.1.6.1. The residual voids content of each core.
  - 6.1.6.2. The locations in the test area from where the cores for voids measurements have been taken.
  - 6.1.6.3. The sound absorption coefficient of each core (if measured). Specify the results both for each core and each frequency range as well as the overall average.
  - 6.1.6.4. The locations in the test area from where the cores for absorption measurement have been taken.
  - 6.1.6.5. Texture depth, including the number of tests and standard deviation.
  - 6.1.6.6. The institution responsible for tests according to paragraphs 6.1.6.1. and 6.1.6.2. and the type of equipment used.
  - 6.1.6.7. Date of the test(s) and date when the cores were taken from the test track.
- 6.2. Documentation of vehicle noise tests conducted on the surface In the document describing the vehicle noise test(s) it shall be stated whether all the requirements of this standard were fulfilled or not. Reference shall be given to a document according to paragraph 6.1. describing the results which verify this.

## Annex 9

### Vehicle and test data pursuant to measurement method B

Information reported in Annex 1 need not to be repeated

1. Trade name or mark of the vehicle .....
2. Vehicle type .....
- 2.1. Maximum mass including semi-trailer (where applicable) .....
3. Manufacturer's name and address .....
4. If applicable, name and address of manufacturer's representative .....
5. Engine:
  - 5.1. Manufacturer: .....
  - 5.2. Type: .....
  - 5.3. Model: .....
  - 5.4. Rated maximum power (ECE): ..... kW at ..... min<sup>-1</sup> (rpm).
  - 5.5. Kind of engine: e.g. positive-ignition, compression ignition, etc.<sup>1</sup>  
.....
  - 5.6. Cycles: two stroke or four-stroke (if applicable) .....
  - 5.7. Cylinder capacity (if applicable) .....
6. Transmission: non-automatic gearbox/automatic gearbox<sup>2</sup>
  - 6.1. Number of gears .....
7. Equipment:
  - 7.1. Exhaust silencer: .....
  - 7.1.1. Manufacturer or authorized representative (if any) .....
  - 7.1.2. Model: .....
  - 7.1.3. Type: ..... in accordance with drawing No.: .....
  - 7.2. Intake silencer: .....
  - 7.2.1. Manufacturer or authorized representative (if any) .....
  - 7.2.2. Model: .....
  - 7.2.3. Type: ..... in accordance with drawing No.: .....
  - 7.3. Elements of capsulation
    - 7.3.1. Elements of noise encapsulation as defined by the vehicle manufacturer

---

<sup>1</sup> If a non-conventional engine is used, this should be stated.

<sup>2</sup> Strike out what does not apply.

- 7.3.2. Manufacturer or authorized representative (if any)
- 7.4. Tyres
- 7.4.1. Tyre size(s) (by axle): .....
- 8. Measurements:
- 8.1. Length of the vehicle ( $l_{veh}$ ): ..... mm
- 8.2. Point of accelerator depression: ..... m before line AA'
- 8.2.1. Engine speed in gear i at:         AA' / PP'<sup>1</sup>     ..... min<sup>-1</sup> (rpm)  
                                                  BB'         ..... min<sup>-1</sup> (rpm)
- 8.2.2. Engine speed in gear (i+1) at:     AA' / PP'<sup>1</sup>     ..... min<sup>-1</sup> (rpm)  
                                                  BB'         ..... min<sup>-1</sup> (rpm)
- 8.3. Type approval number of tyre(s): .....
- If not available, the following information shall be provided:
- 8.3.1. Tyre manufacturer .....
- 8.3.2. Commercial description(s) of the type of tyre (by axle), (e.g. trade name, speed index, load index): .....
- 8.3.3. Tyre size (by axle): .....
- 8.3.4. Type approval number (if available): .....
- 8.4. Noise level of moving vehicle:
- Test result ( $l_{urban}$ ):.....                           dB(A)
- Test result ( $l_{wot}$ ):.....                             dB(A)
- Test result ( $l_{cruise}$ ):.....                         dB(A)
- $k_p$  – factor: .....
- 8.5. Noise level of stationary vehicle:
- Position and orientation of microphone (according to figure 2 in appendix of annex 3)
- Test result for stationary test:.....               dB(A)
- 8.6. Noise level of compressed air sound:
- Test result for:
- (a)   service brake: .....                         dB(A)
- (b)   parking brake: .....                         dB(A)
- (c)   during the pressure regulator actuation: .....   dB(A)
- 9.    Vehicle submitted for approval on: .....
- 10.   Technical Service responsible for type-approval tests: .....
- 11.   Date of test report issued by that service: .....
- 12.   Number of test report issued by that service: .....
- 13.   Position of approval mark on the vehicle .....

14. Place: .....
15. Date: .....
16. Signature: .....
17. The following documents, bearing the approval number shown above, are annexed to this document: .....  
.....  
.....  
  
Drawings and/or photographs, diagrams and plans of the engine and of the noise reduction system;  
  
List of components, duly identified constituting the noise reduction system.
18. Reason for extension of approval: .....
19. Remarks: .....



## Annex 10

### **Methods and instruments for measuring the noise made by motor vehicles (measurement method B)**

1. Measuring instruments

1.1. Acoustic measurements

The apparatus used for measuring the noise level must be a precision sound-level meter or equivalent measurement system meeting the requirements of class 1 instruments (inclusive of the recommended windscreen, if used). These requirements are described in "IEC 61672-1:2002: Precision sound level meters", second edition, of the International Electrotechnical Commission (IEC).

Measurements shall be carried out using the "fast" response of the acoustic measurement instrument and the "A" weighting curve also described in "IEC 61672-1:2002". When using a system that includes a periodic monitoring of the A-weighted sound pressure level, a reading should be made at a time interval not greater than 30 ms.

The instruments shall be maintained and calibrated in accordance to the instructions of the instrument manufacturer.

1.2. Compliance with requirements

Compliance of the acoustic measurement instrumentation shall be verified by the existence of a valid certificate of compliance. These certificates shall be deemed to be valid if certification of compliance with the standards was conducted within the previous 12 months period for the sound calibration device and within the previous 24 months period for the instrumentation system. All compliance testing must be conducted by a laboratory, which is authorized to perform calibrations traceable to the appropriate standards.

1.3. Calibration of the entire Acoustic Measurement System for Measurement Session

At the beginning and at the end of every measurement session, the entire acoustic measurement system shall be checked by means of a sound calibrator that fulfils the requirements for sound calibrators of precision class 1 according to IEC 60942: 2003. Without any further adjustment the difference between the readings shall be less than or equal to 0.5 dB. If this value is exceeded, the results of the measurements obtained after the previous satisfactory check shall be discarded.

1.4. Instrumentation for speed measurements

The engine speed shall be measured with instrumentation having an accuracy of  $\pm 2$  per cent or better at the engine speeds required for the measurements being performed.

The road speed of the vehicle shall be measured with instrumentation having an accuracy of at least  $\pm 0.5$  km/h, when using continuous measurement devices.

If testing uses independent measurements of speed, this instrumentation must meet specification limits of at least  $\pm 0.2$  km/h.

1.5. Meteorological instrumentation

The meteorological instrumentation used to monitor the environmental conditions during the test shall include the following devices, which meet at least the given accuracy:

- (a) Temperature measuring device,  $\pm 1^\circ$  C;
- (b) Wind speed-measuring device,  $\pm 1.0$  m/s;
- (c) Barometric pressure measuring device,  $\pm 5$  hPa;
- (d) A relative humidity measuring device,  $\pm 5$  per cent.

2. Conditions of measurement

2.1. Test Site<sup>1</sup> and ambient conditions

The test site shall be substantially level. The surface of the test track shall be dry. The test site shall be such that when a small omni-directional noise source is placed on its surface at the central point (intersection of the microphone line PP' and the centre line of the vehicle lane CC'), deviations from hemispherical acoustic divergence shall not exceed  $\pm 1$  dB.

This condition is deemed to be satisfied if the following requirements are met:

- (a) Within a radius of 50 m from the centre of the track the space is free of large reflecting objects such as fences, rocks, bridges or buildings.
- (b) The test track and the surface of the site are dry and free from absorbing materials such as powdery snow, or loose debris.
- (c) In the vicinity of the microphone, there are no obstacle that could influence the acoustical field and no person is positioned between the microphone and the noise source. The meter observer is positioned so as not to influence the meter reading.

Measurements shall not be made under adverse weather conditions. It must be ensured that the results are not affected by gusts of wind.

The meteorological instrumentation should be positioned adjacent to the test area at a height of  $1.2 \text{ m} \pm 0.02 \text{ m}$ . The measurements shall be made when the ambient air temperature is within the range from  $5^\circ \text{C}$  to  $40^\circ \text{C}$ .

The tests shall not be carried out if the wind speed, including gusts, at microphone height exceeds 5 m/s, during the noise measurement interval.

A value representative of temperature, wind speed and direction, relative humidity, and barometric pressure shall be recorded during the noise measurement interval.

---

<sup>1</sup> In conformity with Annex 8 to this Regulation.

Any noise peak which appears to be unrelated to the characteristics of the general noise level of the vehicle shall be ignored in taking the readings.

The background noise shall be measured for duration of 10 seconds immediately before and after a series of vehicle tests. The measurements shall be made with the same microphones and microphone locations used during the test. The A-weighted maximum noise pressure level shall be reported.

The background noise (including any wind noise) shall be at least 10 dB below the A-weighted noise pressure level produced by the vehicle under test. If the difference between the ambient noise and the measured noise is between 10 and 15 dB(A), in order to calculate the test results the appropriate correction must be subtracted from the readings on the noise-level meter, as in the following table:

<i>Difference between ambient noise and noise to be measured dB(A)</i>	10	11	12	13	14	15
Correction dB(A)	0.5	0.4	0.3	0.2	0.1	0.0

## 2.2. Vehicle

2.2.1. The vehicle tested shall be selected in a way so that that all vehicles of the same type which are put on the market fulfill the requirements of this Regulation. Measurements shall be made without any trailer, except in the case of non-separable vehicles. Measurements shall be made on vehicles at the test mass  $m_t$  specified according to the following table:

<i>Vehicle category</i>	<i>Vehicle test mass</i>
M <sub>1</sub>	$m_t = m_{ro}$
N <sub>1</sub>	$m_t = m_{ro}$
N <sub>2</sub> , N <sub>3</sub>	<p><math>m_t = 50</math> kg per kW rated engine power</p> <p>Extra loading to reach the test mass of the vehicle shall be placed above the driven rear axle(s). The extra loading is limited to 75 per cent of the maximum mass allowed for the rear axle. The test mass must be achieved with a tolerance of <math>\pm 5</math> per cent.</p> <p>If the centre of gravity of the extra loading cannot be aligned with the center of the rear axle, the test mass of the vehicle shall not exceed the sum of the front axle and the rear axle load in un-laden condition plus the extra loading.</p> <p>The test mass for vehicles with more than two axles shall be the same as for a two-axle vehicle.</p>
M <sub>2</sub> , M <sub>3</sub>	$m_t = m_{ro} - \text{mass of the crew member (if applicable)}$

- 2.2.2. The tyres to be used for the test shall be representative for the axle and shall be selected by the vehicle manufacturer and recorded in Annex 9. They shall correspond to one of the tyre sizes designated for the vehicle as original equipment. The tyre is or will be commercially available on the market at the same time as the vehicle<sup>2</sup>. The tyres shall be inflated to the pressure recommended by the vehicle manufacturer for the test mass of the vehicle. The tyres shall have a tread depth of at least 80 per cent of the full tread depth.
- 2.2.3. Before the measurements are started, the engine shall be brought to its normal operating conditions.
- 2.2.4. If the vehicle is fitted with more than two-wheel drive, it shall be tested in the drive which is intended for normal road use.
- 2.2.5. If the vehicle is fitted with fan(s) having an automatic actuating mechanism, this system shall not be interfered with during the measurements.
- 2.2.6. If the vehicle is equipped with an exhaust system containing fibrous materials, the exhaust system is to be conditioned before the test according to Annex 5.
3. Methods of testing
- 3.1. Measurement of noise of vehicles in motion
- 3.1.1. General conditions of test
- Two lines, AA' and BB', parallel to line PP' and situated respectively 10 m forward and 10 m rearward of line PP' shall be marked out on the test runway.
- At least four measurements shall be made on each side of the vehicle and for each gear. Preliminary measurements may be made for adjustment purposes, but shall be disregarded.
- The microphone shall be located at a distance of  $7.5 \text{ m} \pm 0.05 \text{ m}$  from the reference line CC' of the track and  $1.2 \text{ m} \pm 0.02 \text{ m}$  above the ground.
- The reference axis for free field conditions (see IEC 61672-1:2002) shall be horizontal and directed perpendicularly towards the path of the vehicle line CC'.
- 3.1.2. Specific test conditions for vehicles
- 3.1.2.1. Vehicles of category  $M_1$ ,  $M_2 \leq 3500 \text{ kg}$ ,  $N_1$
- The path of the centreline of the vehicle shall follow line CC' as closely as possible throughout the entire test, from the approach to line AA' until the rear of the vehicle passes line BB'. If the vehicle is fitted with more than two-wheel drive, test it in the drive selection which is intended for normal road use.
- If the vehicle is fitted with an auxiliary manual transmission or a multi-gear axle, the position used for normal urban driving shall be used. In all cases, the gear ratios for slow movements, parking or braking shall be excluded.
- The test mass of the vehicle shall be according to the table of paragraph 2.2.1.

---

<sup>2</sup> The tyre contribution for overall sound emission being important, this vehicle Regulation has taken into account the tyre/road sound emission regulations. Snow tyres and special tyres according to UNECE Regulation No. 117 shall be excluded during type-approval- and COP-measurements on request of the manufacturer.

The test speed  $v_{\text{test}}$  is 50 km/h  $\pm$  1 km/h. The test speed must be reached, when the reference point is at line PP'.

3.1.2.1.1. Power to mass ratio index (PMR)

PMR is defined as follows:

$$\text{PMR} = (P_n / m_t) * 1000 \text{ kg/kW}$$

The power to mass ratio index (PMR) is used for the calculation of acceleration.

3.1.2.1.2. Calculation of acceleration

Acceleration calculations are applicable to  $M_1$ ,  $N_1$  and  $M_2 \leq 3500$  kg categories only.

All accelerations are calculated using different speeds of the vehicle on the test track<sup>3</sup>. The formulas given are used for the calculation of  $a_{\text{wot } i}$ ,  $a_{\text{wot } i+1}$  and  $a_{\text{wot test}}$ . The speed either at AA' or PP' is defined as the vehicle speed when the reference point passes AA' ( $v_{\text{AA}'}$ ) or PP' ( $v_{\text{PP}'}$ ). The speed at BB' is defined when the rear of the vehicle passes BB' ( $v_{\text{BB}'}$ ). The method used for determination of the acceleration shall be indicated in the test report.

Due to the definition of the reference point for the vehicle the length of the vehicle ( $l_{\text{veh}}$ ) is considered differently in the formula below. If the reference point is in the front of the vehicle, then  $l = l_{\text{veh}}$ , mid:  $l = \frac{1}{2} l_{\text{veh}}$  and rear:  $l = 0$ .

3.1.2.1.2.1. Calculation procedure for vehicles with manual transmission, automatic transmission, adaptive transmissions and transmissions with variable gear ratios (CVT's) tested with locked gear ratios:

$$a_{\text{wot test}} = ((v_{\text{BB}'}/3.6)^2 - (v_{\text{AA}'}/3.6)^2) / (2*(20+l))$$

$a_{\text{wot test}}$  used in the determination of gear selection shall be the average of the four  $a_{\text{wot test, } i}$  during each valid measurement run.

Pre-acceleration may be used. The point of depressing the accelerator before line AA' shall be reported in the vehicle and test data (see annex 9).

3.1.2.1.2.2. Calculation procedure for vehicles with automatic transmissions, adaptive transmissions and CVT's tested with non-locked gear ratios:

$a_{\text{wot test}}$  used in the determination of gear selection shall be the average of the four  $a_{\text{wot test, } i}$  during each valid measurement run.

If devices or measures described in paragraph 3.1.2.1.4.2., can be used to control transmission operation for the purpose of achieving test requirements, calculate  $a_{\text{wot test}}$  using the equation:

$$a_{\text{wot test}} = ((v_{\text{BB}'}/3.6)^2 - (v_{\text{AA}'}/3.6)^2) / (2*(20+l))$$

Pre-acceleration may be used.

If no devices or measures described in paragraph 3.1.2.1.4.2. are used, calculate  $a_{\text{wot test}}$  using the equation:

$$a_{\text{wot test PP-BB}} = ((v_{\text{BB}'}/3.6)^2 - (v_{\text{PP}'}/3.6)^2) / (2*(10+l))$$

Pre-acceleration shall not be used.

<sup>3</sup> See Annex 8, figure 1

The location of depressing the accelerator shall be where the reference point of the vehicle passes line AA'.

3.1.2.1.2.3. Target acceleration

The target acceleration  $a_{\text{urban}}$  defines the typical acceleration in urban traffic and is derived from statistical investigations. It is a function depending on the PMR of a vehicle.

The target acceleration  $a_{\text{urban}}$  is defined by:

$$a_{\text{urban}} = 0.63 * \log_{10} (\text{PMR}) - 0.09$$

3.1.2.1.2.4. Reference acceleration

The reference acceleration  $a_{\text{wot ref}}$  defines the required acceleration during the accelerated test on the test track. It is a function depending on the power-to-mass ratio of a vehicle. That function is different for specific vehicle categories.

The reference acceleration  $a_{\text{wot ref}}$  is defined by:

$$a_{\text{wot ref}} = 1.59 * \log_{10} (\text{PMR}) - 1.41 \quad \text{for PMR} \geq 25$$

$$a_{\text{wot ref}} = a_{\text{urban}} = 0.63 * \log_{10} (\text{PMR}) - 0.09 \quad \text{for PMR} < 25$$

3.1.2.1.3. Partial power factor  $k_p$

The partial power factor  $k_p$  (see paragraph 3.1.3.1.) is used for the weighted combination of the test results of the acceleration test and the constant speed test for vehicles of category  $M_1$  and  $N_1$ .

In cases other than a single gear test  $a_{\text{wot ref}}$  has to be used instead of a  $a_{\text{wot test}}$  (see paragraph 3.1.3.1.).

3.1.2.1.4. Gear ratio selection

The selection of gear ratios for the test depends on their specific acceleration potential  $a_{\text{wot}}$  under full throttle condition, according to the reference acceleration  $a_{\text{wot ref}}$  required for the full throttle acceleration test.

Some vehicles may have different software programs or modes for the transmission (e.g. sporty, winter, adaptive). If the vehicle has different modes leading to valid accelerations, the vehicle manufacturer has to prove to the satisfaction of the Technical Service, that the vehicle is tested in the mode which achieves an acceleration being closest to  $a_{\text{wot ref}}$ .

3.1.2.1.4.1. Vehicles with manual transmission, automatic transmissions, adaptive transmissions or CVT's tested with locked gear ratios

The following conditions for selection of gear ratios are possible:

- (a) If one specific gear ratio gives an acceleration in a tolerance band of  $\pm 5$  per cent of the reference acceleration  $a_{\text{wot ref}}$ , not exceeding  $2.0 \text{ m/s}^2$ , test with that gear ratio.
- (b) If none of the gear ratios give the required acceleration, then choose a gear ratio  $i$ , with an acceleration higher and a gear ratio  $i+1$ , with an acceleration lower than the reference acceleration. If the acceleration value in gear ratio  $i$  does not exceed  $2.0 \text{ m/s}^2$ , use both gear ratios for the test. The weighting ratio in relation to the reference acceleration  $a_{\text{wot ref}}$  is calculated by:

$$k = (a_{\text{wot ref}} - a_{\text{wot (i+1)}})/(a_{\text{wot (i)}} - a_{\text{wot (i+1)}})$$

- (c) If the acceleration value of gear ratio  $i$  exceeds  $2.0 \text{ m/s}^2$ , the first gear ratio shall be used that gives an acceleration below  $2.0 \text{ m/s}^2$  unless gear ratio  $i+1$  provides acceleration less than  $a_{\text{urban}}$ . In this case, two gears,  $i$  and  $i+1$  shall be used, including the gear  $i$  with acceleration exceeding  $2.0 \text{ m/s}^2$ . In other cases, no other gear shall be used. The achieved acceleration  $a_{\text{wot test}}$  during the test shall be used for the calculation of the part power factor  $k_p$  instead of  $a_{\text{wot ref}}$ .
- (d) If the vehicle has a transmission in which there is only one selection for the gear ratio the acceleration test is carried out in this vehicle gear selection. The achieved acceleration is then used for the calculation of the part power factor  $k_p$  instead of  $a_{\text{wot ref}}$ .
- (e) If rated engine speed is exceeded in a gear ratio before the vehicle passes BB' the next higher gear shall be used.

3.1.2.1.4.2. Vehicles with automatic transmission, adaptive transmissions and CVT's tested with non-locked gear ratios:

The gear selector position for full automatic operation shall be used.

The acceleration value  $a_{\text{wot test}}$  shall be calculated as defined in paragraph 3.1.2.1.2.2.

The test may then include a gear change to a lower range and a higher acceleration. A gear change to a higher range and a lower acceleration is not allowed. A gear shifting to a gear ratio which is not used in urban traffic shall be avoided.

Therefore, it is permitted to establish and use electronic or mechanical devices, including alternate gear selector positions, to prevent a downshift to a gear ratio which is typically not used at the specified test condition in urban traffic.

The achieved acceleration  $a_{\text{wot test}}$  shall be greater or equal to  $a_{\text{urban}}$ .

If possible, the manufacturer shall take measures to avoid an acceleration value  $a_{\text{wot test}}$  greater than  $2.0 \text{ m/s}^2$ .

The achieved acceleration  $a_{\text{wot test}}$  is then used for the calculation of the partial power factor  $k_p$  (see paragraph 3.1.2.1.3.) instead  $a_{\text{wot ref}}$ .

3.1.2.1.5. Acceleration test

The manufacturer shall define the position of the reference point in front of line AA' of fully depressing the accelerator. The accelerator shall be fully depressed (as rapidly as is practicable) when the reference point of the vehicle reaches the defined point. The accelerator shall be kept in this depressed condition until the rear of the vehicle reaches line BB'. The accelerator shall then be released as rapidly as possible. The point of fully depressing the accelerator shall be reported in the vehicle and test data (annex 9). The Technical Service shall have the possibility of pretesting.

In the case of articulated vehicles consisting of two non-separable units regarded as a single vehicle, the semi-trailer shall be disregarded in determining when line BB' is crossed.

3.1.2.1.6. Constant speed test

The constant speed test shall be carried out with the same gear(s) specified for the acceleration test and a constant speed of 50 km/h with a tolerance of  $\pm 1$  km/h between AA' and BB'. During the constant speed test the acceleration control shall be positioned to maintain a constant speed between AA' and BB' as specified. If the gear is locked for the acceleration test, the same gear shall be locked for the constant speed test.

The constant speed test is not required for vehicles with a PMR < 25.

3.1.2.2. Vehicles of categories  $M_2 > 3500$  kg,  $M_3$ ,  $N_2$ ,  $N_3$

The path of the centreline of the vehicle shall follow line CC' as closely as possible throughout the entire test, from the approach to line AA' until the rear of the vehicle passes line BB'. The test shall be conducted without a trailer or semi-trailer. If a trailer is not readily separable from the towing vehicle the trailer shall be ignored when considering the crossing of line BB'. If the vehicle incorporates equipment such as a concrete mixer, a compressor, etc, this equipment shall not be in operation during the test. The test mass of the vehicle shall be according to the table of paragraph 2.2.1.

Target conditions of category  $M_2 > 3500$  kg,  $N_2$ :

When the reference point passes line BB', the engine speed  $n_{BB'}$  shall be between 70 per cent and 74 per cent of speed S, at which the engine develops its rated maximum power, and the vehicle speed shall be  $35 \text{ km/h} \pm 5 \text{ km/h}$ . Between line AA' and line BB' a stable acceleration condition shall be ensured.

Target conditions of category  $M_3$ ,  $N_3$ :

When the reference point passes line BB', the engine speed  $n_{BB'}$  shall be between 85 per cent and 89 per cent of speed S, at which the engine develops its rated maximum power, and the vehicle speed shall be  $35 \text{ km/h} \pm 5 \text{ km/h}$ . Between line AA' and line BB' a stable acceleration condition shall be ensured.

3.1.2.2.1. Gear ratio selection

3.1.2.2.1.1. Vehicles with manual transmissions

Stable acceleration condition shall be ensured. The gear choice is determined by the target conditions. If the difference in speed exceeds the given tolerance, then two gears should be tested, one above and one below the target speed.

If more than one gear fulfils the target conditions select that gear which is closest to 35 km/h. If no gear fulfils the target condition for  $v_{\text{test}}$  two gears shall be tested, one above and one below  $v_{\text{test}}$ . The target engine speed shall be reached in any condition.

A stable acceleration condition shall be ensured. If a stable acceleration cannot be ensured in a gear, this gear has to be disregarded.

3.1.2.2.1.2. Vehicles with automatic transmissions, adaptive transmissions and transmissions with variable gear ratio (CVT's)

The gear selector position for full automatic operation shall be used. The test may then include a gear change to a lower range and a higher acceleration. A gear change to a higher range and a lower acceleration is not allowed. A gear



shifting to a gear ratio which is not used in urban traffic, at the specified test condition, shall be avoided. Therefore, it is permitted to establish and use electronic or mechanical devices to prevent a downshift to a gear ratio which is typically not used at the specified test condition in urban traffic.

If the vehicle includes a transmission design, which provides only a single gear selection (drive), which limits engine speed during the test, the vehicle shall be tested using only a target vehicle speed. If the vehicle uses an engine and transmission combination that does not fulfil paragraph 3.1.2.2.1.1., the vehicle shall be tested using only the target vehicle speed. The target vehicle speed for the test is  $v_{BB'} = 35 \text{ km/h} \pm 5 \text{ km/h}$ . A gear change to a higher range and a lower acceleration is allowed after the reference point of the vehicle passes line PP'. Two tests must be performed, one with the end speed of  $v_{\text{test}} = v_{BB'} + 5 \text{ km/h}$ , and one with the end speed of  $v_{\text{test}} = v_{BB'} - 5 \text{ km/h}$ . The reported noise level is that result which is related to the test with the highest engine speed obtained during the test from AA' to BB'.

#### 3.1.2.2.2. Acceleration test

When the reference point of the vehicle reaches the line AA' the accelerator control shall be fully depressed (without operating the automatic downshift to a lower range than normally used in urban driving) and held fully depressed until the rear of the vehicle passes BB', but the reference point shall be at least 5 m behind BB'. The accelerator control shall then be released.

In the case of articulated vehicles consisting of two non-separable units regarded as a single vehicle, the semi-trailer shall be disregarded in determining when line BB' is crossed.

#### 3.1.3. Interpretation of results

The maximum A-weighted sound pressure level indicated during each passage of the vehicle between the two lines AA' and BB' shall be noted. If a noise peak obviously out of character with the general sound pressure level is observed, the measurement shall be discarded. At least four measurements for each test condition shall be made on each side of the vehicle and for each gear ratio. Left and right side may be measured simultaneously or sequentially. The first four valid consecutive measurement results, within 2 dB(A), allowing for the deletion of non valid results (see paragraph 2.1.), shall be used for the calculation of the final result for the given side of the vehicle. The results of each side shall be averaged separately. The intermediate result is the higher value of the two averages mathematically rounded to the first decimal place.

The speed measurements at AA', BB', and PP' shall be noted and used in calculations to the first significant digit after the decimal place.

The calculated acceleration  $a_{\text{wot test}}$  shall be noted to the second digit after the decimal place.

#### 3.1.3.1. Vehicles of categories M<sub>1</sub>, N<sub>1</sub> and M<sub>2</sub> ≤ 3500 kg

The calculated values for the acceleration test and the constant speed test are given by:

$$L_{\text{wot rep}} = L_{\text{wot}(i+1)} + k * (L_{\text{wot}(i)} - L_{\text{wot}(i+1)})$$

$$L_{\text{crs rep}} = L_{\text{crs}(i+1)} + k * (L_{\text{crs}(i)} - L_{\text{crs}(i+1)})$$

Where  $k = (a_{\text{wot ref}} - a_{\text{wot (i+1)}}) / (a_{\text{wot (i)}} - a_{\text{wot (i+1)}})$

In the case of a single gear ratio test the values are the test result of each test.

The final result is calculated by combining  $L_{\text{wot rep}}$  and  $L_{\text{crs rep}}$ . The equation is:

$$L_{\text{urban}} = L_{\text{wot rep}} - k_p * (L_{\text{wot rep}} - L_{\text{crs rep}})$$

The weighting factor  $k_p$  gives the part power factor for urban driving. In cases other than a single gear test  $k_p$  is calculated by:

$$k_p = 1 - (a_{\text{urban}} / a_{\text{wot ref}})$$

If only one gear was specified for the test  $k_p$  is given by:

$$k_p = 1 - (a_{\text{urban}} / a_{\text{wot test}})$$

In cases where  $a_{\text{wot test}}$  is less than  $a_{\text{urban}}$ :

$$k_p = 0$$

3.1.3.2. Vehicles of categories  $M_2 > 3500$  kg,  $M_3$ ,  $N_2$ ,  $N_3$

When one gear is tested the final result is equal to the intermediate result. When two gears are tested the arithmetic mean of the intermediate results shall be calculated.

3.2. Measurement of noise emitted by stationary vehicles

3.2.1. Sound level in the vicinity of vehicles

The measurement results shall be entered into the test report referred to in Annex 9.

3.2.2. Acoustic measurements

A precision sound level meter, or equivalent measuring system, as defined in paragraph 1.1. of this annex shall be used for the measurements.

3.2.3. Test site - local conditions (see appendix of annex 3, figure 1)

3.2.3.1. In the vicinity of the microphone, there shall be no obstacle that could influence the acoustical field and no person shall remain between the microphone and the noise source. The meter observer shall be positioned so as not to influence the meter reading.

3.2.4. Disturbance sound and wind interference

Readings on the measuring instruments produced by ambient noise and wind shall be at least 10 dB(A) below the sound level to be measured. A suitable windscreen may be fitted to the microphone provided that account is taken of its effect on the sensitivity of the microphone (see paragraph 1.1. of this annex).

3.2.5. Measuring method

3.2.5.1. Nature and number of measurements

The maximum sound level expressed in A-weighted decibels (dB(A)) shall be measured during the operating period referred to in paragraph 3.2.5.3.2.1.

At least three measurements shall be taken at each measuring point.

3.2.5.2. Positioning and preparation of the vehicle

The vehicle shall be located in the centre part of the test area with the gear selector in the neutral position and the clutch engaged. If the design of the

vehicle does not allow this, the vehicle shall be tested in conformity with the manufacturer's prescriptions for stationary engine testing. Before each series of measurements, the engine must be brought to its normal operating condition, as specified by the manufacturer.

If the vehicle is fitted with fan(s) having an automatic actuating mechanism, this system shall not be interfered with during the sound level measurements.

The engine hood or compartment cover, if so fitted, shall be closed.

3.2.5.3. Measuring of noise in proximity to the exhaust (see appendix of annex 3, figure 1)

3.2.5.3.1. Positions of the microphone

3.2.5.3.1.1. The microphone shall be located at a distance of  $0.5 \text{ m} \pm 0.01 \text{ m}$  from the reference point of the exhaust pipe defined in Figure 1, and at an angle of  $45^\circ (\pm 5^\circ)$  to the flow axis of the pipe termination. The microphone shall be at the height of the reference point, but not less than 0.2 m from the ground surface. The reference axis of the microphone shall lie in a plane parallel to the ground surface and shall be directed toward the reference point on the exhaust outlet. If two microphone positions are possible, the location farthest laterally from the vehicle longitudinal centreline shall be used. If the flow axis of the exhaust outlet pipe is at  $90^\circ$  to the vehicle longitudinal centreline, the microphone shall be located at the point, which is farthest from the engine.

3.2.5.3.1.2. For vehicles having an exhaust provided with outlets spaced more than 0.3 m apart, measurements shall be made for each outlet. The highest level shall be recorded.

3.2.5.3.1.3. In the case of an exhaust provided with two or more outlets spaced less than 0.3 m apart and which are connected to the same silencer, only one measurement is made; the microphone position is related to the outlet nearest to one extreme edge of the vehicle or, when such outlet does not exist, to the outlet which is the highest above the ground.

3.2.5.3.1.4. For vehicles with a vertical exhaust (e.g. commercial vehicles) the microphone shall be placed at the height of the exhaust outlet. Its axis shall be vertical and oriented upwards. It shall be placed at a distance of  $0.5 \text{ m} \pm 0.01 \text{ m}$  from the exhaust pipe reference point, but never less than 0.2 m from the side of the vehicle nearest to the exhaust.

For exhaust outlets located under the vehicle body, the microphone shall be located a minimum of 0.2 m from the nearest part of the vehicle, at a point closest to, but never less than 0.5 m from the exhaust pipe reference point, and at a height of 0.2 m above the ground, and not in line with the exhaust flow. The angularity requirement in paragraph 3.2.5.3.1.2. may not be met in some cases.

3.2.5.3.2. Operating conditions of the engine

3.2.5.3.2.1. Target engine speed

The target engine speed is defined as:

- (a) 75 per cent of the engine speed  $S$  for vehicles with a rated engine speed  $\leq 5,000 \text{ min}^{-1}$
- (b)  $3,750 \text{ min}^{-1}$  for vehicles with a rated engine speed above  $5,000 \text{ min}^{-1}$  and below  $7,500 \text{ min}^{-1}$

- (c) 50 per cent of the engine speed  $S$  for vehicles with a rated engine speed  $\geq 7,500 \text{ min}^{-1}$ .

If the vehicle cannot reach the engine speed as stated above, the target engine speed shall be 5 per cent below the maximum possible engine speed for that stationary test.

3.2.5.3.2.2. Test procedure

The engine speed shall be gradually increased from idle to the target engine speed, not exceeding a tolerance band of  $\pm 3$  per cent of the target engine speed, and held constant. Then the throttle control shall be rapidly released and the engine speed shall return to idle. The noise level shall be measured during a period of operation consisting of a maintenance of constant engine speed of 1 second and throughout the entire deceleration period, the maximum sound level meter reading, mathematically rounded to the first decimal place, is taken as the test value.

3.2.5.3.2.3. Test validation

The measurement shall be regarded as valid if the test engine speed does not deviate from the target engine speed by more than  $\pm 3$  per cent for at least 1 second.

3.2.6. Results

At least three measurements for each test position shall be made. The maximum A-weighted sound pressure level indicated during each of the three measurements shall be recorded. The first three valid consecutive measurement results, within 2 dB(A), allowing for the deletion of non valid results (see paragraph 2.1. except the specifications of the test site), shall be used for the determination of the final result for the given measurement position. The maximum sound level, for all measurement positions, and of the three measurement results, constitutes the final result.

---