

21 November 2019

Agreement

Concerning the Adoption of Harmonized Technical United Nations Regulations for Wheeled Vehicles, Equipment and Parts which can be Fitted and/or be Used on Wheeled Vehicles and the Conditions for Reciprocal Recognition of Approvals Granted on the Basis of these United Nations Regulations*

(Revision 3, including the amendments which entered into force on 14 September 2017)

Addendum 52 – UN Regulation No. 53

Revision 3 – Amendment 7

Supplement 20 to 01 series of amendments – Date of entry into force: 15 October 2019

Installation of lighting and light-signalling devices for L₃ vehicles

This document is meant purely as documentation tool. The authentic and legal binding text is: ECE/TRANS/WP.29/2019/18 (as amended by ECE/TRANS/WP.29/1145, paragraph 108, ECE/TRANS/WP.29/2018/87/Rev.1 and ECE/TRANS/WP.29/2018/105 as amended by ECE/TRANS/WP.29/1145, paragraph 112).



UNITED NATIONS

* Former titles of the Agreement:
Agreement concerning the Adoption of Uniform Conditions of Approval and Reciprocal Recognition of Approval for Motor Vehicle Equipment and Parts, done at Geneva on 20 March 1958 (original version);
Agreement concerning the Adoption of Uniform Technical Prescriptions for Wheeled Vehicles, Equipment and Parts which can be Fitted and/or be Used on Wheeled Vehicles and the Conditions for Reciprocal Recognition of Approvals Granted on the Basis of these Prescriptions, done at Geneva on 5 October 1995 (Revision 2).

GE.19-19430(E)



* 1 9 1 9 4 3 0 *

Please recycle 



Insert a new paragraph 2.34., to read:

"2.34. "Exterior courtesy lamp" means a lamp used to provide supplementary illumination to assist the mounting and dismounting of the vehicle driver and passenger or in loading operations."

Paragraph 5.8.1., amend to read:

"5.8.1. The photometric characteristics of a direction indicator lamp except for categories 5 and 6 specified in UN Regulation No. 6 or 148, and of a direction indicator lamp specified in UN Regulation No. 50 or 148 may be varied during a flash by sequential activation of light sources as specified in paragraph 5.6. of UN Regulation No. 6 or paragraph 5.6.11. of UN Regulation No. 148 or in paragraph 6.8. of UN Regulation No. 50.

This provision shall not apply when direction indicator lamps of categories 2a and 2b of UN Regulation No. 6 or 148 or category 12 of UN Regulation No. 50 or 148 are operated as emergency stop signal according to paragraph 6.14. of this Regulation."

Paragraph 5.14.4., amend to read:

"5.14.4. Stop lamp, S1 category device specified in UN Regulation No. 7 or 148 or stop lamp specified in UN Regulation No. 50 (paragraph 6.4.) or stop lamp for category L vehicles in UN Regulation No 148;"

Paragraph 5.15.4., amend to read:

"5.15.4. Stop lamp, S3 category device specified in UN Regulation No. 7 (paragraph 6.4.) or 148;"

Paragraph 5.9., amend to read:

"5.9. No red light which could give rise to confusion shall be emitted from a lamp as defined in paragraph 2.5. in a forward direction and no white light which could give rise to confusion, shall be emitted from a lamp as defined in paragraph 2.5. in a rearward direction. No account shall be taken of lighting devices fitted for the interior lighting of the vehicle. In case of doubt, this requirement shall be verified as follows (see drawing in Annex 4)..."

Paragraph 5.13., amend to read:

"5.13. Colours of the lights

...

Emergency stop signal: amber or red

Exterior courtesy lamp: white"

Insert a new paragraph 5.15.6., to read:

"5.15.6. Exterior courtesy lamp (paragraph 6.15.)."

Paragraph 6.1.1.1., amend to read:

"6.1.1.1. For motorcycles having a cylinder capacity $\leq 125 \text{ cm}^3$

...

(i) Class A, B, D, BS, CS, DS or ES of UN Regulation No. 149"

Paragraph 6.1.1.2., amend to read:

"6.1.1.2. For motorcycles having a cylinder capacity $> 125 \text{ cm}^3$

...

(h) Class A, B, D, BS, DS or ES of UN Regulation No. 149

..."

Paragraph 6.2.1.1., amend to read:

"6.2.1.1. For motorcycles having a cylinder capacity $\leq 125 \text{ cm}^3$

...

(i) Class A, B, D, BS, CS, DS or ES of UN Regulation No. 149"

Paragraph 6.2.1.2., amend to read:

"6.2.1.2. For motorcycles having a cylinder capacity $> 125 \text{ cm}^3$

One or two of approved type according to:

(a) Class B, D or E of UN Regulation No. 113;

(b) UN Regulation No. 112;

(c) UN Regulation No. 1;

(d) UN Regulation No. 8;

(e) UN Regulation No. 20;

(f) UN Regulation No. 72;

(g) UN Regulation No. 98;

(h) Class A, B, D, BS, DS or ES of UN Regulation No. 149

Two of approved type according to:

(i) Class C of UN Regulation No. 113;

(j) Class CS of UN Regulation No. 149"

Paragraph 6.2.3.1.4., amend to read:

"6.2.3.1.4. If installed, additional lighting unit(s) which provide bend lighting, type approved as part of the passing-beam according to UN Regulation No. 113 or 149, shall be installed under the following conditions:

In the case of (a) pair(s) of additional lighting units, they shall be installed so that their reference centre(s) are symmetrical in relation to the median longitudinal plane of the vehicle.

In the case of a single additional lighting unit, its reference centre shall be coincident with the median longitudinal plane of the vehicle."

Paragraph 6.2.5.7., amend to read:

"6.2.5.7. Additional light source(s) or additional lighting unit(s) may be activated only in conjunction with the principal passing-beam or the driving-beam to produce bend lighting. The illumination provided by the bend lighting shall not extend above the horizontal plane that is parallel with the ground and containing the reference axis of the headlamp producing the principal passing-beam for all bank angles as specified by the manufacturer during type approval of the device according to UN Regulation No. 113 or 149."

Paragraph 6.2.5.8., amend to read:

"6.2.5.8. The requirement in paragraph 6.2.5.7. above shall be tested as follows:

The test vehicle shall be set as specified in paragraph 5.4. of this Regulation. Measure the bank angles on both sides of the vehicle under every condition where the bend lighting is activated. The bank angles to measure are the bank angles specified by the manufacturer during type approval of the device according to UN Regulation No. 113 or 149.

The handlebar may be fixed in the straight ahead position so as not to move during the vehicle inclination.

For the test, the bend lighting may be activated by means of a signal generator provided by the manufacturer.

The system is considered to satisfy the requirements of paragraph 6.2.5.7. above, if all measured bank angles on both sides of the vehicle are greater than or equal to the minimum bank angles given in the communication form for the type approval of the device according to UN Regulation No. 113 or 149.

Conformity to paragraph 6.2.5.7. above may be demonstrated by the manufacturer using other means accepted by the Type Approval Authority responsible for type approval."

Paragraph 6.2.6., amend to read:

"6.2.6. Electrical connections

The control for changing over to the passing-beam(s) shall switch off the driving-beam(s) simultaneously. Passing-beam headlamps with a light source approved in accordance with UN Regulation No. 99 shall remain switched on when the driving-beam is illuminated.

6.2.6.1. The additional light source(s) or additional lighting unit(s) used to produce bend lighting shall be so connected that it (they) cannot be activated unless the headlamp(s) producing the principal passing-beam or the driving-beam is (are) also activated.

The additional light source(s) or additional lighting unit(s) used to produce bend lighting on each side of the vehicle may only be automatically activated when the bank angle(s) is(are) greater or equal to the minimum bank angle(s) given in the communication form for the type approval of the device according to UN Regulation No. 113 or 149.

However, the additional light source(s) or additional lighting unit(s) shall not be activated when the bank angle is less than three degrees.

The additional light source(s) or additional lighting unit(s) shall be deactivated when the bank angle(s) is (are) less than the minimum bank angle(s) given in the communication form for the type approval of the device according to UN Regulation No. 113 or 149."

Paragraph 6.3.2., amend to read:

"6.3.2. Arrangement

Two front indicators (category 1 as specified in UN Regulation No. 6 or 148 or category 11 specified in UN Regulation No. 50 or 148).

Two rear indicators (category 2 as specified in UN Regulation No. 6 or 148 or category 12 specified in UN Regulation No. 50 or 148)."

Paragraph 6.3.6., amend to read:

- "6.3.6. Electrical connections
- 6.3.6.1. The direction indicator lamps shall switch on independently of the other lamps. All direction indicator lamps on one side of a vehicle shall be switched on and off by means of one control.
- 6.3.6.2. The direction indicator lamps may be switched ON to indicate the status of the device for protection of vehicles against unauthorized use.
- 6.3.6.3. The indication described in paragraph 6.3.6.2. shall be produced by the simultaneous operation of the direction indicator lamps and shall be in accordance to the following conditions.
- | | |
|-----------------------------------|------------------------|
| In case of single indication: | 3 seconds maximum |
| In case of continuous indication: | |
| Duration: | 5 minutes maximum |
| Frequency: | (2 ± 1) Hz |
| On time: | Off time ± 10 per cent |
- This indication shall be allowed only when the device which starts and/or stops the engine (propulsion system) is set in a position which makes it impossible for the engine (propulsion system) to operate."

Paragraph 6.3.7. shall be deleted.

Paragraphs 6.3.8. to 6.3.9.4. (former), renumber as paragraphs 6.3.7. to 6.3.8.4. respectively.

Paragraph 6.4.1., amend to read:

- "6.4.1. Number
- One or two approved as a category S1 device according to UN Regulation No. 7 or 148 or stop lamp according to UN Regulation No. 50 or stop lamp for category L vehicles of UN Regulation No. 148.
- Optional one approved as a category S3 device according to UN Regulation No. 7 or 148."

Paragraph 6.4.3., amend to read:

- "6.4.3. Position
- 6.4.3.1. For category S1 device specified in UN Regulation No. 7 or UN Regulation No. 148 or stop lamp specified in UN Regulation No. 50 or 148
- In height: not less than 250 mm nor more than 1,500 mm above the ground;
- In length: at the rear of the vehicle.
- 6.4.3.2. For the category S3 device specified in UN Regulation No. 7 or 148
- In height: The horizontal plane tangential to the lower edge of the apparent surface shall not be less than 850 mm above the ground.
- However, the horizontal plane tangential to the lower edge of the apparent surface shall be above the horizontal plane tangential to the upper edge of the apparent surface of the category S1 device specified in UN Regulation No. 7 or

148 or stop lamp specified in UN Regulation No. 50 or stop lamp for category L vehicles of UN Regulation No. 148.

In length: at the rear of the vehicle."

Paragraph 6.4.4., amend to read:

"6.4.4. Geometric visibility

For category S1 device specified in UN Regulation No. 7 or 148 or stop lamp specified in UN Regulation No. 50 or stop lamp for category L vehicles of UN Regulation No. 148

Horizontal angle: 45° to left and to right for a single lamp;

45° outwards and 10° inwards for each pair of lamps;

Vertical angle: 15° above and below the horizontal.

However, where a lamp is mounted below 750 mm (measured according to the provisions of paragraph 5.7.), the downward angle of 15° may be reduced to 5°.

For category S3 device specified in UN Regulation No. 7 or 148

Horizontal angle: 10° to the left and to the right of the longitudinal axis of the vehicle.

Vertical angle: 10° above and 5° below the horizontal."

Paragraph 6.5.1., amend to read:

"6.5.1. Number

One, approved as a category 2 device according to UN Regulation No. 50 or 148. The device may consist of several optical components designed to illuminate the space reserved for the registration plate."

Paragraph 6.13.2., amend to read:

"6.13.2. Number

One or two of approved type according to UN Regulation No. 87 or 148."

Insert a new paragraph 6.15., to read:

"6.15. Exterior courtesy lamp

6.15.1. Presence

Optional for motorcycles.

6.15.2. Number

One or two; however further exterior courtesy lamps to illuminate footrest are permitted. Each footrest shall be illuminated by not more than one lamp.

6.15.3. Arrangement

No special requirement, however the requirements of paragraph 6.15.9.3. apply.

6.15.4. Position

No special requirement.

6.15.5. Geometric visibility

No special requirement.

- 6.15.6. Orientation
No special requirement.
- 6.15.7. Electrical connections
No special requirement.
- 6.15.8. Tell-tale
No special requirement.
- 6.15.9. Other requirements
- 6.15.9.1. The exterior courtesy lamp shall not be activated unless the vehicle is stationary and one or more of the following conditions is satisfied:
- (a) The device which starts and/or stops the engine (propulsion system) is set in a position which makes it impossible for the engine (propulsion system) to operate; or
 - (b) A load compartment is opened for access.
- The provisions of paragraph 5.9. shall be met in all fixed positions of use.
- 6.15.9.2. Approved lamps emitting white light with the exception of main beam headlamps and day time running lamps may be activated as courtesy lamp function. They may also be activated together with the exterior courtesy lamps and the condition of paragraphs 5.10. and 5.11. above may not apply.
- 6.15.9.3. The technical service shall, to the satisfaction of the Type Approval Authority, perform a visual test to verify that there is no direct visibility of the apparent surface of the exterior courtesy lamps, if viewed by an observer moving on the boundary of a zone on a transverse plane 10 m from the front of the vehicle, a transverse plane 10 m from the rear of the vehicle, and two longitudinal planes 10 m from each side of the vehicle; these four planes to extend from 1 m to 3 m above and perpendicular to the ground as shown in Annex 7.
- In addition to the conditions described in paragraph 5.4., the requirements prescribed above shall be verified in the following vehicle conditions:
- Stand: On a prop stand or a centre stand, and both if applicable
 - Steering: Straight ahead, and locked in each available position
- At the request of the applicant and with the consent of the Technical Service this requirement may be verified by a drawing or simulation."

Annex 1

Insert a new item 9.22., to read:

"9.22. Exterior courtesy lamp: yes/no²"

Insert a new Annex 7, to read:

"Annex 7

Observing area towards the apparent surface of exterior courtesy lamps

Zones of observation

This drawing shows the zone from one side, the other zones are from the front, the rear and from the other side of the vehicle.

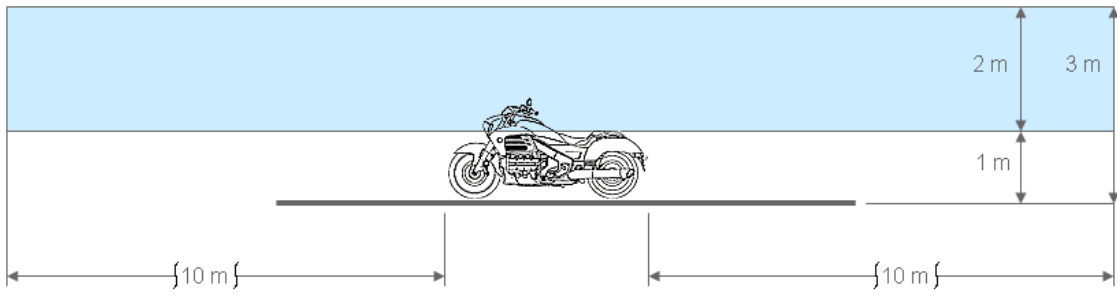

Boundaries of the zones

