

26 January 2017

Agreement

Concerning the Adoption of Uniform Technical Prescriptions for Wheeled Vehicles, Equipment and Parts which can be Fitted and/or be Used on Wheeled Vehicles and the Conditions for Reciprocal Recognition of Approvals Granted on the Basis of these Prescriptions*

(Revision 2, including the amendments which entered into force on 16 October 1995)

Addendum 134 – Regulation No. 135

Revision 1 - Amendment 1

Supplement 1 to the 01 series of amendments – Date of entry into force: 25 August 2016

Uniform provisions concerning the approval of vehicles with regard to their Pole Side Impact performance (PSI)

This document is meant purely as documentation tool. The authentic and legal binding text is: ECE/TRANS/WP.29/2015/71.



UNITED NATIONS

* Former title of the Agreement: Agreement Concerning the Adoption of Uniform Conditions of Approval and Reciprocal Recognition of Approval for Motor Vehicle Equipment and Parts, done at Geneva on 20 March 1958.

Paragraph 1.1., amend to read:

"1.1. This Regulation applies to:

- (a) Category M₁ vehicles with a gross vehicle mass of up to 3500 kg; and
- (b) Category N₁ vehicles where the acute angle alpha (α), measured between a horizontal plane passing through the centre of the front axle and an angular transverse plane passing through the centre of the front axle and the R-point of the driver's seat, as illustrated below, is less than 22.0 degrees; or the ratio between the distance from the driver's R-point to the centre of the rear axle (L101-L114) and the centre of the front axle and the driver's R-point (L114) is less than 1.30.²

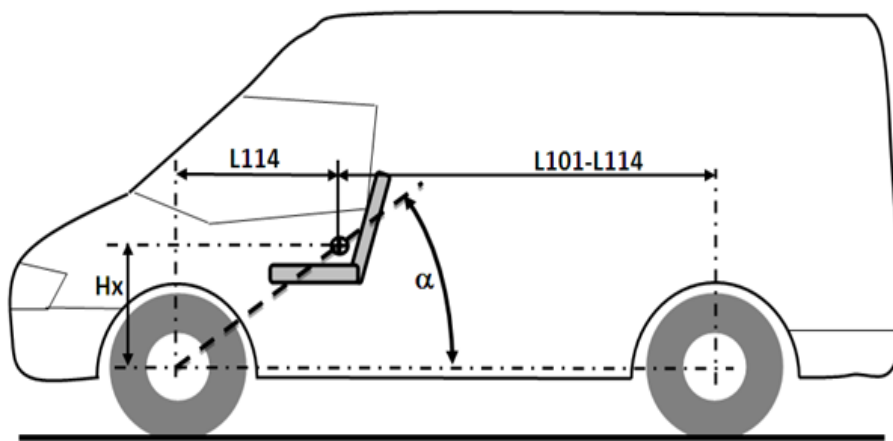

² As defined in the Consolidated Resolution on the Construction of Vehicles (R.E.3.), document ECE/TRANS/WP.29/78/Rev.4, para. 2 - www.unece.org/trans/main/wp29/wp29wgs/wp29gen/wp29resolutions.html