

26 July 2017

Agreement

Concerning the Adoption of Uniform Technical Prescriptions for Wheeled Vehicles, Equipment and Parts which can be Fitted and/or be Used on Wheeled Vehicles and the Conditions for Reciprocal Recognition of Approvals Granted on the Basis of these Prescriptions*

(Revision 2, including the amendments which entered into force on 16 October 1995)

Addendum 109 — Regulation No. 110

Revision 3 — Amendment 5

Supplement 5 to the 01 series of amendments — Date of entry into force: 22 June 2017

Uniform provisions concerning the approval of:

I. Specific components of motor vehicles using compressed natural gas (CNG) and/or liquefied natural gas (LNG) in their propulsion system

II. Vehicles with regard to the installation of specific components of an approved type for the use of compressed natural gas (CNG) and/or liquefied natural gas (LNG) in their propulsion system

This document is meant purely as documentation tool. The authentic and legal binding texts is: ECE/TRANS/WP.29/2016/95.



UNITED NATIONS

* Former title of the Agreement: Agreement Concerning the Adoption of Uniform Conditions of Approval and Reciprocal Recognition of Approval for Motor Vehicle Equipment and Parts, done at Geneva on 20 March 1958.

Paragraph 7.1., correct "paragraphs 8.12. to 8.21." to read "paragraphs 8.12. to 8.22."

Paragraph 18.5.1.3., amend to read:

"18.5.1.3. Notwithstanding the provisions of paragraph 18.5.1.2.

- (a) The automatic cylinder valve may stay in an open position during commanded stop phases; and
- (b) In the case where a fire alarm system is installed in the compartment where a CNG combustion heater is located, the automatic cylinder valve(s) may be opened by an electronic control unit for the purpose of permitting its operation to warm the engine coolant."

Annex 4A, paragraph 4.2.4., correct "of Class 1 and Class 2" to read "of Class 2".

Annex 4B, paragraph 1.6.2.2., amend to read:

"1.6.2.2. The interface type for the hose coupling shall be:

- (a) Sealing cone of swivel-nut type of the type with a half vertical angle of 45°; or
- (b) Other couplings complying with the tests described in paragraph 1.7., as well as the tests mentioned in Annexes 5A and 5B.

In the case of an interface type using a soft seal body (e.g. O-ring), the type of material chosen shall be tested in accordance with Annexes 5D, 5F and 5G.

Couplings shall have complementary counterparts."

Annex 4H, paragraph 2.2., correct "than 5 seconds" to read "than 2 seconds".

Annex 4J

Paragraph 2.2., shall be deleted.

Paragraph 3.1.6., correct "shall be not be" to read "shall not be".

Insert new paragraphs 4. and 4.1., to read:

"4. LNG filling receptacle dimensions

4.1. Figure 1 shows the dimensions of the LNG filling receptacle.

Figure 1
Dimensions of the receptacle

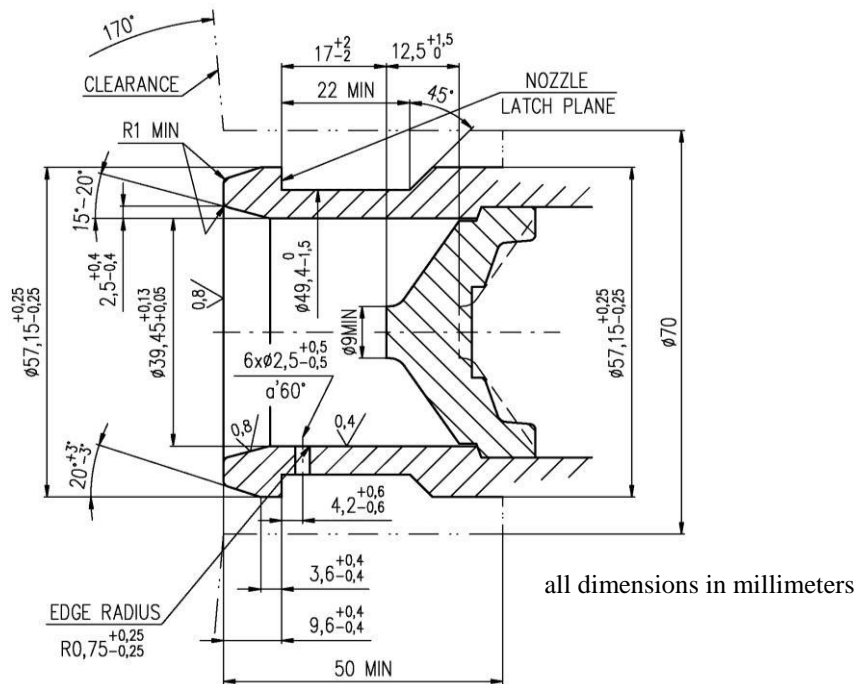

The 50 mm dimension is the minimum distance to the mounting flange