

22 February 2017

Agreement

Concerning the Adoption of Uniform Technical Prescriptions for Wheeled Vehicles, Equipment and Parts which can be Fitted and/or be Used on Wheeled Vehicles and the Conditions for Reciprocal Recognition of Approvals Granted on the Basis of these Prescriptions*

(Revision 2, including the amendments which entered into force on 16 October 1995)

Addendum 89 – Regulation No. 90

Revision 3 - Amendment 3

Supplement 3 to the 02 series of amendments – Date of entry into force: 9 February 2017

Uniform provisions concerning the approval of replacement brake lining assemblies, drum-brake linings and discs and drums for power-driven vehicles and their trailers

This document is meant purely as documentation tool. The authentic and legal binding text is: ECE/TRANS/WP.29/2016/58.



UNITED NATIONS

* Former title of the Agreement: Agreement Concerning the Adoption of Uniform Conditions of Approval and Reciprocal Recognition of Approval for Motor Vehicle Equipment and Parts, done at Geneva on 20 March 1958.

Add a new paragraph 1.1.5., to read:

"1.1.5. Replacement brake discs intended for use in friction brakes forming part of a braking system of vehicles of categories L₁, L₂, L₃, L₄ and L₅, which have a type approval in accordance with Regulation No. 78"

Paragraph 2.3.1.1., amend to read:

"2.3.1.1. In the case of motor vehicles, is a brake disc/drum covered by the vehicle braking system type approval according to Regulations Nos. 13, 13-H or 78."

Paragraph 2.3.3.1., amend to read:

"2.3.3.1. Original replacement brake discs and brake drums"

Add new paragraphs 2.3.3.1.1. and 2.3.3.1.2., to read:

"2.3.3.1.1. In the case of vehicle categories M, N and O: original brake discs/ brake drums intended for servicing the vehicle and carrying an identification code as defined in paragraph 2.3.2. affixed in such a way as to be indelible and clearly legible.

2.3.3.1.2. In the case of vehicle categories L₁, L₂, L₃, L₄ and L₅: original brake discs/ brake drums intended for servicing the vehicle."

Paragraph 2.3.3.2., amend to read:

"2.3.3.2. Identical brake discs"

Add new paragraphs 2.3.3.2.1. and 2.3.3.2.2., to read:

"2.3.3.2.1. In the case of vehicle categories M, N and O: a replacement brake disc which is chemically and physically identical in every respect with the exception of the vehicle manufacturer mark, which is absent, to the original brake disc.

2.3.3.2.2. In the case of vehicle categories L₁, L₂, L₃, L₄ and L₅: a replacement brake disc which is chemically and physically identical in every respect."

Add a new paragraph 2.3.3.4., to read:

"2.3.3.4. Equivalent brake discs and brake drums"

Renumber former paragraph 2.3.3.4. as 2.3.3.4.1. and amend to read:

"2.3.3.4.1. "Equivalent brake discs for categories M, N and O" is a replacement brake disc which is identical to the original brake disc in respect to all dimensions, geometric features and basic design and is also from the same material subgroup as the original brake disc as defined in paragraph 5.3.3.2."

Add a new paragraph 2.3.3.4.2., to read:

"2.3.3.4.2. "Equivalent brake discs for categories L₁, L₂, L₃, L₄ and L₅" are replacement brake discs which are identical to the original brake disc in respect to all dimensions, geometric features and basic design and is also from the same following materials:

- (a) Braking surface: one of materials listed in paragraph 5.3.3.2.2;
- (b) Bell and braking ring fasteners: same materials and mechanical properties of original disc"

Renumber former paragraph 2.3.3.5. as 2.3.3.4.3.

Add a new paragraph 2.3.3.5., to read:

"2.3.3.5. Interchangeable brake discs and brake drums"

Renumber paragraph 2.3.3.6. as 2.3.3.5.1.

Renumber paragraph 2.3.3.7. as 2.3.3.5.2.

Paragraph 3.4.1.1., amend to read:

"3.4.1.1. Disc or drum drawing(s) ... accessories:

- (a) ...
- (b) ...
- (c) Material (for one piece discs) or material for composed and floating disc of categories L₁, L₂, L₃, L₄ and L₅."

Paragraph 3.4.1.2., amend to read:

"3.4.1.2. Component description

The manufacturer ... information:

- (a) The manufacturer...
- ...
- (d) Material composition, specifically:
 - (i) ...
 - (ii) ...
 - (iii) Mechanical properties for cast iron brake discs and brake drums;
 - a. Brinell hardness pursuant to ISO 6506-1:2005
 - b. Tensile strength in accordance with ISO 6892:1998
 - (iv) Mechanical properties for martensitic stainless steel brake disc:
 - a. Rockwell C hardness pursuant to ISO 6508-1
- (e) Corrosion ...
- ...

The applicant shall submit the information and specifications outlined in Annex 9, Part B, paragraph 2.5. for cast iron discs and Annex 9, Part C, paragraph 2.5. for martensitic stainless steel discs, of this Regulation."

Paragraph 3.4.2.1., amend to read:

"3.4.2.1. The applicant shall submit the documentation in accordance with Annex 9, Part B and Part C, paragraph 2. of this Regulation."

Paragraph 3.4.3.1., amend to read:

"3.4.3.1. A minimum number of disc or drum samples – of the design for which approval is requested – shall be provided, as shown in the following table.

The table also shows the recommended use of the samples.

| Item No. | Check/Test | Sample number for brake discs for vehicles of categories M, N and O | | | | | | Remarks |
|----------|---|---|---|---|---|---|---------------|-----------------------------|
| | | 1 | 2 | 3 | 4 | 5 | 6 | |
| 1 | Geometric check Paragraphs 5.3.3.1., 5.3.4.1. | x | x | x | x | x | x | |
| 2 | Material check Paragraphs 5.3.3.2. | x | x | | | | | |
| 3 | Balancing provisions check Paragraph 5.3.7.2. | | | x | x | x | x | |
| 4 | Wear condition marking check Paragraph 5.3.7.3. | | | x | x | x | x | |
| 5 | Integrity test – thermal fatigue Paragraphs 4.1.1., 4.2.1. of Annex 11, 4.1.1., 4.2.1. of Annex 12 | | | | x | x | | |
| 6 | Integrity test – high load test Paragraphs 4.1.2., 4.2.2. of Annex 11, and paragraphs 4.1.2., 4.2.2. of Annex 12 | | | x | | | | |
| 7 | Service brake vehicle performance test Paragraph 2.2. of Annex 11, Paragraph 2.2. of Annex 12 | | | | | | Pair of discs | Either front or rear axle |
| 8 | Parking brake vehicle performance test Paragraph 2.3. of Annex 11, Paragraph 2.3. of Annex 12 | | | | | | Pair of discs | If applicable |
| 9 | Service brake dynamometer performance test Paragraph 3.3. of Annex 11, paragraph 3.3. of Annex 12 | | | | | | x | Alternative to vehicle test |

| Item No. | Check / Test | Sample number for brake discs for vehicles of categories L ₁ , L ₂ , L ₃ , L ₄ and L ₅ | | | | | Remarks |
|----------|--|---|---|---|---|---|---------|
| | | 1 | 2 | 3 | 4 | 5 | |
| 1 | Geometric check Paragraphs 5.3.3.1., 5.3.4.1. | x | x | x | x | x | |
| 2 | Wear condition marking check Paragraph 5.3.7.3. | x | x | x | x | x | |
| 3 | Material and hardness braking surface Paragraphs 5.3.3.2. | x | | | | | |

| Item No. | Check / Test | Sample number for brake discs for vehicles of categories L ₁ , L ₂ , L ₃ , L ₄ and L ₅ | | | | | Remarks |
|----------|---|---|---|---|---|---|-----------------------------|
| | | 1 | 2 | 3 | 4 | 5 | |
| 4 | Bell and fasteners material check Paragraphs 2.4. and 2.5. of Annex 15 | x | | | | | |
| 5 | Resistance to static torque test Paragraph 2. of Annex 14 | | x | x | | | |
| 6 | Service brake vehicle performance Paragraphs 3.2. of Annex 14 | | | | x | | |
| 7 | Thermal fatigue Paragraph 5.1. of annex 14 | | | | | x | |
| 8 | Service brake dynamometer performance Paragraph 4.3. of Annex 14 | | | | | | Alternative to vehicle test |

Paragraph 5.1.2., amend to read:

"5.1.2. Replacement discs and replacement drums conforming to the identification code specified in vehicle type approval documentation to Regulation No. 13 or to Regulation No. 13-H and replacement discs conforming to the type specified in vehicle type approval documentation to Regulation No. 78, are deemed to satisfy the requirements of paragraph 5. of this Regulation."

Paragraph 5.3, amend to read:

"5.3. Technical requirements...

...

Depending on its group, the replacement brake disc or drum has to pass the following tests:

| | <i>Resistance to static torque (only for vehicle categories L₁, L₂, L₃, L₄ and L₅)</i> | <i>Performance tests according to Regulations Nos. 13/13-H/78 (Type 0, I, II, etc.)</i> | <i>Comparison test with dynamic frictional properties of the original part</i> | <i>Integrity tests (high load and thermal fatigue)</i> |
|----------------------------|---|---|--|--|
| Original replacement parts | Disc not subjected to this regulation | | | |
| Identical parts | No | No | No | No |
| Equivalent parts | No | No | No | Dynamometer test |
| Interchangeable parts | Static bench test | Vehicle test or alternative dynamometer test | Vehicle test or alternative dynamometer test | Dynamometer test |

The test requirements for brake discs and drums for vehicles of categories M and N are detailed in Annex 11.

The test requirements for brake discs and drums for vehicles of category O are detailed in Annex 12.

The test requirements for brake discs for vehicles of categories L₁, L₂, L₃, L₄ and L₅ are detailed in Annex 14."

Paragraph 4.2.3., amend to read:

"4.2.3. The next series of digits shall indicate the manufacture and the type of the brake lining, the type of disc or the type of drum.

The digital suffix shall indicate:

- (a) The shoe or back plate or specific dimension in the case of drum brake linings;
- (b) The Test Group in the case of a replacement disc or replacement drum.

The variants approved as a Test Group shall be listed as an appendix to the communication document:

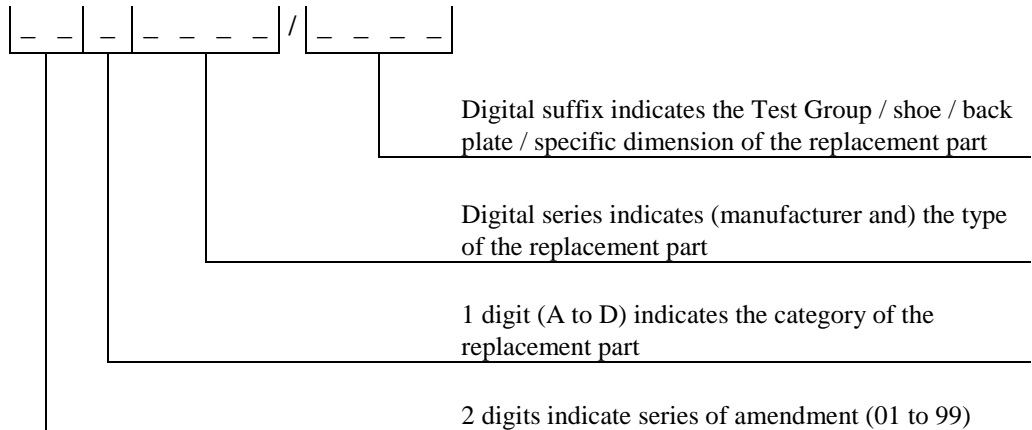

Example:

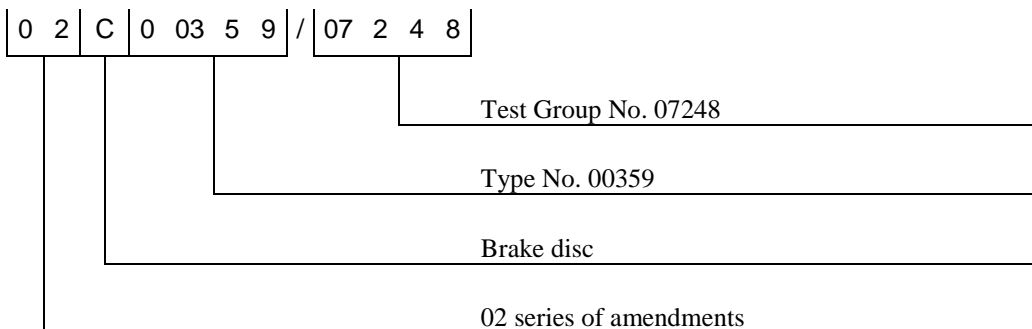

"

Paragraph 5.3.3.1.1., amend to read:

"5.3.3.1.1. For discs the following maximum values shall be met:

| | M_1, N_1, O_1, O_2 | $M_2, M_3, N_2, N_3, O_3, O_4$ | L_1, L_2, L_3, L_4, L_5 |
|--|----------------------|--------------------------------|---------------------------|
| Thickness variation | 0.015 mm | 0.030 mm | 0.020 mm |
| Cheek thickness variation (for ventilated disc only) | 1.5 mm | 2.0 mm | (****) |
| Lateral run-out friction surface | 0.050 mm* | 0.150 mm* | 0.150 mm*** |
| Location bore variation | H9 | H9 | D10 or H11 ***** |
| "Top hat" parallelism | 0.100 mm | 0.100 mm | --- |
| Location face flatness | 0.050 mm | 0.050 mm | 0.100 mm |
| Friction surface roughness** | 3.2 µm | 3.2 µm | 1.6 µm |

* n/a in the case of a floating disc.

** Ra-value according to ISO 1302:2002.

*** 0.100 mm for maximum straightness for "full floating" disc (without elastic constraints between bell and braking ring)

**** n/a for vehicles categories L₁, L₂, L₃, L₄ and L₅

***** Location bore variation where applicable, related to manufacturing process.

"

Add a new paragraph 5.3.3.2.1., to read:

"5.3.3.2.1. For vehicles of category M, N, O, in order to be considered "Equivalent" the replacement brake disc or drum shall be from the same material sub-group as the original brake disc or drum. Four original part material sub-groups are defined."

Add a new paragraph 5.3.3.2.2., to read:

"5.3.3.2.2. Martensitic stainless steel for braking ring of vehicles of categories L₁, L₂, L₃, L₄ and L₅. In order to be considered "Equivalent" the replacement brake disc shall be from the same material subgroup as the original brake disc. Five original part material subgroups are defined.

| | Test standard | Subgroup 1 JIS SUS 410 | Subgroup 2 X 10 Cr 13 EN 10088/2 | Subgroup 3 X 12 Cr 13 EN 10088/2 | Subgroup 4 X 20 Cr 13 EN 10088/2 | Subgroup 5X 30 Cr 13 EN 10088/2 |
|------------------------------|---------------|---------------------------|--|--|--|---------------------------------------|
| Carbon Content (per cent) | | 0.02-0.10 | 0.08-0.12 | 0.08-0.15 | 0.16-0.25 | 0.26-0.35 |
| Silicon Content (per cent) | | Max 0.80 | Max 1.00 | Max 1.00 | Max 1.00 | Max 1.00 |
| Manganese Content (per cent) | | 0.50-2.50 | Max 1.00 | Max 1.50 | Max 1.50 | Max 1.50 |
| Chromium Content (per cent) | | 10.00-14.50 | 12.00-14.00 | 11.50-13.50 | 12.00-14.00 | 12.00-14.00 |

| | <i>Test standard</i> | <i>Subgroup 1 JIS SUS 410</i> | <i>Subgroup 2 X 10 Cr 13 EN 10088/2</i> | <i>Subgroup 3 X 12 Cr 13 EN 10088/2</i> | <i>Subgroup 4 X 20 Cr 13 EN 10088/2</i> | <i>Subgroup 5X 30 Cr 13 EN 10088/2</i> |
|-------------------------|----------------------|-----------------------------------|---|---|---|--|
| Iron Content (per cent) | | rest | | | | |
| Hardness HRC | ISO 6508-1:2005 | 30-40 | 30-40 | 30-40 | 30-40 | 30-40 |

Add a new paragraph 5.3.3.3.1., to read:

"5.3.3.3.1. Brake disc and brake drum for categories M, N and O

The part has to pass the integrity tests for high load and thermal fatigue according to Annexes 11 and 12."

Add a new paragraph 5.3.3.3.2., to read:

"5.3.3.3.2. Brake disc for categories L₁, L₂, L₃, L₄ and L₅

The part has to pass the integrity tests for high load and thermal fatigue according to Annexes 14."

Paragraph 5.3.4.2., amend to read:

"5.3.4.2. Performance requirements

The part shall pass the following performance tests according to Annexes 11 and 12 for categories M, N and O and Annex 14 for categories L₁, L₂, L₃, L₄ and L₅:

- (a) The performance test according to Regulations Nos. 13 or 13-H or 78;
- (b) The Comparison test with dynamic frictional properties of the original part;
- (c) The integrity tests for high load and thermal fatigue. "

Paragraph 5.3.5.1.2., amend to read:

"5.3.5.1.2. Material group

For brake discs for vehicles of categories M, N and O, all material groups (including their respective subgroups) are considered to be a separate type.

For brake discs for vehicles of categories L₁, L₂, L₃, L₄ and L₅, all material groups (excluding the martensitic stainless steel subgroup) are considered to be a separate type."

Paragraph 5.3.6., amend to read:

"5.3.6. Test group criteria (within the same type)

It is only possible to test interchangeable parts in Test Groups if the connection between the mounting area and the disc friction faces are of the same general form...

...

With:

| | |
|----------------------------------|--|
| $V_{\max, i}$ | maximum design speed of the vehicle to which the replacement part is fitted (in the case of trailers $v_{\max, i}$ is assumed at least at 80 km/h) |
| m | test mass as defined in Annex 11, paragraph 3.2.1.2., Annex 12, paragraph 3.2.1.2. and Annex 14, paragraph 4.2.1.2. |
| $m_{\text{replacement part, i}}$ | mass of the replacement part of the corresponding vehicle" |

Add new paragraphs 5.3.6.1.3. and 5.3.6.1.3.1., to read:

"5.3.6.1.3. Criteria concerning the formation of test groups with regard to replacement brake discs in vehicles belonging to categories L₁, L₂, L₃, L₄ and L₅.

5.3.6.1.3.1. Test group relating to the tests stipulated of Annex 14.

This test group includes all brake discs according to the criteria set out in Annex 15."

Paragraph 5.3.7.4., amend to read:

"5.3.7.4. Tests

Each test group (see paragraph 5.3.6.) within a particular type of replacement brake disc/drum (see paragraph 5.3.5.) shall be tested by the Technical Service."

Paragraph 5.3.3.1., amend to read:

"5.3.3.1. Geometric requirements

The brake discs or drums shall be identical to the original brake disc or drum in respect to all dimensions, geometric features, tolerances and basic design."

Paragraphs 5.3.3.1.1. and 5.3.3.1.2., shall be deleted

Paragraph 5.3.4.1., amend to read:

"5.3.4.1. Geometric requirements

As paragraphs 5.3.4.1.1 and 5.3.4.1.2 plus the same interface dimensions.

An interchangeable replacement ...

5.3.4.1.1. For discs, the following maximum values shall be met:

| | M_1, N_1, O_1, O_2 | $M_2, N_2,$ | M_3, N_3, O_3, O_4 |
|---|----------------------|-------------|----------------------|
| Thickness variation | 0.015 mm | 0.030 mm | 0.040 mm |
| Cheek thickness variation (for ventilated disc only) | 1.5 mm | 2.0 mm | 2.0 mm |
| Lateral run-out friction surface | 0.050 mm* | 0.15 mm* | 0.15 mm* |
| Location bore variation | H9 | H9 | H9 |
| "Top hat" parallelism | 0.100 mm | 0.100 mm | 0.100 mm |
| Location face flatness | 0.050 mm | 0.050 mm | 0.050 mm |
| Friction surface roughness** | 3.2 µm | 3.2 µm | 3.2 µm |

| | | | |
|--|----------------------|-------------|----------------------|
| | M_1, N_1, O_1, O_2 | $M_2, N_2,$ | M_3, N_3, O_3, O_4 |
|--|----------------------|-------------|----------------------|

* N/A in the case of a floating disc

** Ra-value according to ISO 1302:2002

5.3.4.1.2 For drums, the following maximum values shall be met:

| | M_1, N_1, O_1, O_2 | $M_2, M_3, N_2, N_3, O_3, O_4$ |
|---------------------------------|----------------------|--------------------------------|
| Radial run-out friction surface | 0.050 mm | 0.100 mm |
| Location bore variation | H9 | H9 |
| Ovality | 0.040 mm | 0.150 mm |
| Location face flatness | 0.050 mm | 0.050 mm |
| Friction surface roughness* | 3.5 μ m | 3.5 μ m |

* Ra-value according to ISO 1302:2002

"

Annex 9,

Title of Part B, amend to read:

"Part B: Conformity of production for brake discs and drums in cast iron"

Add Part C, to read:

"Part C: Conformity of production for brake discs in martensitic stainless steel"

1. Introduction
Part C applies to replacement brake discs approved to this Regulation.
2. Requirements
Conformity of production is to be demonstrated through the routine control and documentation of at least the following:
 - 2.1. Chemical composition
 - 2.2. Mechanical properties
Rockwell C hardness measured in accordance with ISO 6508-1:2005.
In each case the measurements must be made on samples taken from the actual brake disc or drum.
 - 2.3. Geometric features
Brake Discs:
 - (a) Thickness variation;

- (b) Friction surface run out;
- (c) Friction surface roughness.

2.4. Acceptance criteria

With each application for approval of a replacement brake disc or drum there shall be submitted a production specification covering:

- (a) Chemical composition and its permitted range, or where appropriate, maximum value, for each element;
- (b) Mechanical properties as per paragraph 2.3. and their permitted range, or where appropriate, minimum value.

During routine production of an approved replacement brake disc or drum production must demonstrate compliance with these registered specifications.

In the case of geometric features the values prescribed in paragraph 5.3.3.1.1. for brake discs must not be exceeded.

2.5. Documentation

The documentation shall contain the manufacturer's maximum and minimum permitted values.

2.6. Test frequency

The measurements prescribed in this annex should be carried out for each production batch."

Annex 10,

Paragraph 1., amend to read:

- "1. Brake disc design types for M, N and O categories (examples)
 ..."

Paragraph 2., amend to read:

- "2. Brake drum for M, N and O categories (examples)
 ..."

Add a new paragraph 3., to read:

- "3. Brake disc design types for L₁, L₂, L₃, L₄ and L₅ categories (examples)
 One-piece type: brake disc with braking surface and bell made in a single piece and, therefore, of the same material

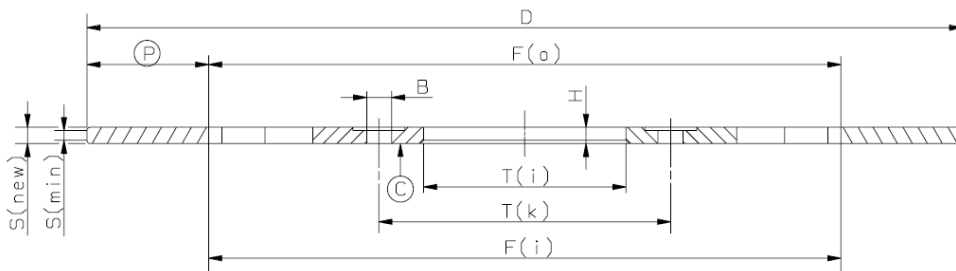

Composed fixed type: brake disc having the braking ring made of steel, while the bell is of other material, generally aluminium; the 2 components are rigidly bounded by a screwed or riveted connection.

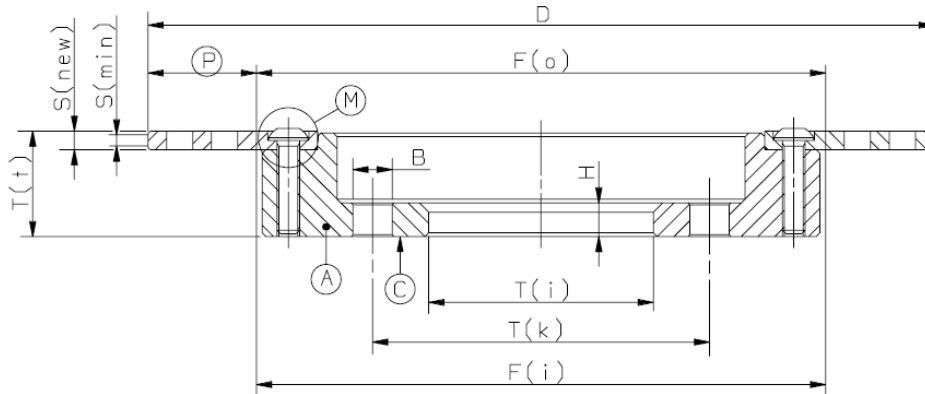

Floating type: brake disc having the braking ring radially released from the bell, in order to allow its thermal expansion.

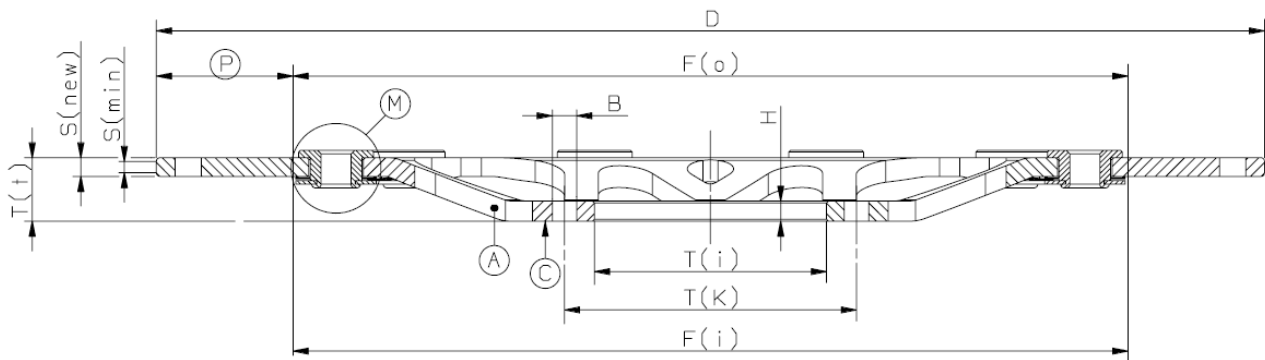

- B Diameter of mounting bolt holes (or thread size in case of threaded holes)
- D External diameter of disc
- F_(i) Inner diameter of friction surface (inboard)
- F_(o) Inner diameter of friction surface (outboard)
- H Mounting flange thickness
- S_(new) Disc thickness (nominal)
- S_(min) Disc thickness (minimal permissible wear thickness)
- T_(i) Internal diameter (mounting spigot diameter)
- T_(k) "x" number of mounting bolt holes and pitch circle diameter
- T_(t) Overall length of disc"

Annex 13,

Item 8, amend to read:

"8. This test has been carried out and the results reported in accordance with Regulation No. 90 as last amended by the 03 series of amendments"

Add a new Annex 14, to read:

"Annex 14

Requirements for replacement brake discs for vehicles of categories L₁, L₂, L₃, L₄ and L₅

1. Test overview

The tests required in paragraph 5.3. of this Regulation are detailed as follows according to the vehicle category.

Table A14/1.

| | <i>Static bench test</i> | <i>Vehicle test</i> | <i>Alternative dynamometer test</i> |
|--|--------------------------|--|--|
| Resistance to static torque test | 2. | --- | --- |
| Performance tests according to Regulation No. 78 | --- | 3.2.3. Dry stop test | 4.4.1. Dry stop test |
| | | 3.2.4. Wet brake test | --- |
| | | 3.2.5. Heat fade test | 4.4.2. Heat fade test |
| Comparison test with original part | --- | 3.2.6. Testing the dynamic frictional properties | 4.4.3. Testing the dynamic frictional properties |
| Integrity test | --- | No vehicle test – use dynamometer test | 5.1. Brake disc thermal fatigue test |

For each disc type, at least one test group (see definition in paragraph 5.3.6. of this Regulation) requires the "Dry stop", "Wet brake" and "Heat fade" tests to be carried out on a vehicle.

2. Static bench test requirements

2.1. Purpose

To verify the resistance of the bell and, in case of floating discs, of the connection system to the braking ring when the disc is subjected to a braking torque.

2.2. Test procedure and conditions

Static test performed on special test bench shown in Figure 1.

Figure 1

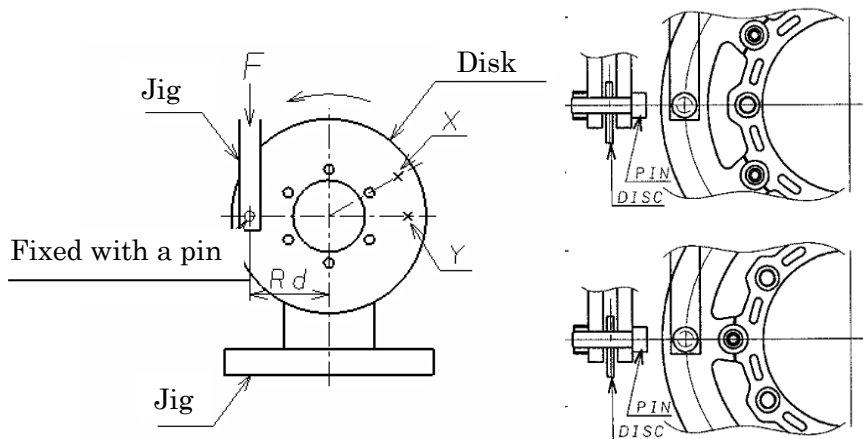

- 2.2.1. Drill a hole on the braking surface of the disc at a distance from the centre equal to the effective radius R_d .
- 2.2.2. Position the disc on the test bench and fasten it using specific fastening screws.
- 2.2.3. Connect the bench arm to the hole drilled on the brake disc.
- 2.2.4. Apply the force F , specified in Table A14/2.2.5., as shown in Figure 1.
- 2.2.5. Record strokes and forces as shown in Figure 2.

Table A14/2.2.5.

| Disc Diameter [mm] | Disc Thickness [mm] | Tangential force F [kN] min |
|-----------------------|------------------------|----------------------------------|
| $\geq 150 < 200$ | ≤ 4 | ≥ 8 |
| | > 4 | ≥ 10 |
| $\geq 200 < 250$ | ≤ 3 | ≥ 8 |
| | $> 3 \leq 4$ | ≥ 10 |
| | > 4 | ≥ 12 |
| $\geq 250 < 300$ | ≤ 3 | ≥ 8 |
| | $> 3 \leq 4$ | ≥ 10 |
| | > 4 | ≥ 12 |
| $\geq 300 < 350$ | ≤ 4 | ≥ 8 |
| | $> 4 \leq 5$ | ≥ 11 |
| | > 5 | ≥ 14 |

- 2.2.6. N.B.: The test shall be conducted in 2 positions:
 - 2.2.6.1. Floating and composite fixed disc
 - With hole on braking surface, coincident with a connection bush.
 - With hole on braking surface, coincident with the centre line between 2 connection bushes.

- 2.2.6.2. One piece disc
With hole on braking surface, coincident with a fixing hole.
With hole on braking surface, coincident with the centre line between 2 fixing holes.

Figure 2
Movement

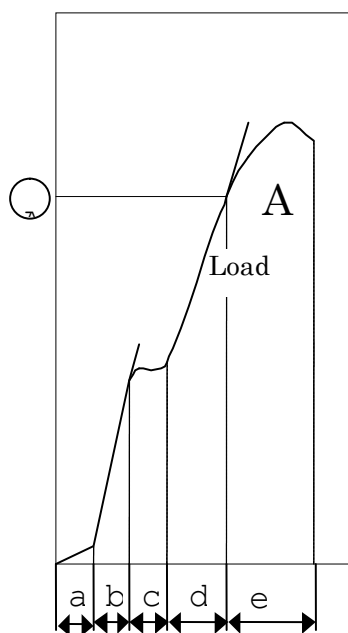

Where:

- (a) Adjustment stroke of the equipment (recovery of any clearance between the hole on the braking surface and the connection pin to the bench arm);
 - (b) Load developed by the fastening screws to the equipment;
 - (c) Movement of the brake disc caused by its rotation with sliding on the plate of the equipment, when the disc's fastening screws bear against the fixing holes of the disc;
 - (d) Load supported by the brake disc;
 - (e) Permanent deformation of the brake disc (starting from point A).
- 2.3. Test results

The disc shall not permanent deformations before reaching the force F specified in Table A14/2.2.5; the measurement of the deformation force must be performed at point A as in Figure 2.

3. Verification of the vehicle test requirements

3.1. Test vehicle

A vehicle that is representative for the selected test group (see definition in paragraph 5.3.6. of this Regulation) in respect of which an approval or parts report for a replacement brake disc is applied for shall be fitted with this

replacement brake disc as well as be equipped with test devices for testing the brakes pursuant to the provisions of Regulation No. 78.

The replacement brake disc shall be fitted to the wheel in question together with an accompanying brake lining which has been type approved according to Regulations Nos. 78 or 90, available from the vehicle.

Unless a uniform procedure is laid down for how braking is to effected, the test shall be carried out following agreement with the Technical Service. All the tests listed below shall be carried out on brakes that have been bedded in.

The same "bedding-in" programme shall be used for both replacement and original brake discs.

3.2. Service braking system

3.2.1. Brake temperature measurement

This procedure shall be carried out pursuant to Regulation No.78, Annex 3, paragraph 2.4.

3.2.2. Burnishing procedure

This procedure shall be carried out pursuant to Regulation No.78, Annex 3, paragraph 2.5.

3.2.3. Dry stop test

This test shall be carried out pursuant to Regulation No. 78, Annex 3, paragraph 3.

3.2.4. Wet brake test

This test shall be carried out pursuant to Regulation No. 78, Annex 3, paragraph 6.

3.2.5. Heat fade test

The test is applicable to vehicle categories L₃, L₄ and L₅.

This test shall be carried out pursuant to Regulation No. 78, Annex 3, paragraph 7.

3.2.6. Testing the dynamic frictional properties (comparison test conducted on the individual wheel)

For this test, the vehicle shall be laden and all brake applications carried out on a flat road with the engine disconnected.

The service braking system of the vehicle shall be provided with a device that separates the front-wheel brake from the rear-wheel brake so that they can always be operated independently of one another.

If an approval or a part report is required in connection with a replacement brake disc for the front-wheel brake, the rear-wheel brakes shall remain inoperative throughout the test.

If an approval or a part report is required in connection with a replacement brake disc for the rear-wheel brake, the front-wheel brake shall remain inoperative throughout the test.

3.2.6.1. Performance comparison test when the brakes are cold

With cold brakes, the performance of the replacement brake disc shall be compared with the original equivalent by comparing the results of the test below.

3.2.6.2. Using the replacement brake disc, at least six consecutive brake applications with different, gradually increasing control forces or brake pressures are carried out as part of the process up to the point at which the wheel lock, or up to a mean fully developed deceleration of 6 m/s^2 or up to the maximum control force or line pressure permitted for this category of vehicle, in which connection the initial speed for the testing of front or rear wheel brake disc is as per the table below:

Table A14/3.2.6.2.

| Vehicle category | Test speed in km/h | |
|------------------|--------------------|------------|
| | Front wheel | Rear wheel |
| L1, L2, | 30 | 30 |
| L3, L4, L5, | 70 | 45 |

Prior to each brake application, the initial temperature of the brake disc shall be $\leq 80 \text{ }^\circ\text{C}$.

3.2.6.3. The brake test described in paragraph 3.2.6.2. also has to be carried out using the original brake disc.

3.2.6.4. The dynamic frictional properties of the replacement brake disc can be regarded as similar to those of the original brake disc, provided the values attained in relation to the mean fully developed deceleration at the same operating pressures or control forces in the region of the upper 2/3 of the curve generated do not deviate by either ± 15 per cent or $\pm 0.4 \text{ m/s}^2$ from those of the original brake disc (see an example of the curve in Figures 3 and 4).

Figure 3

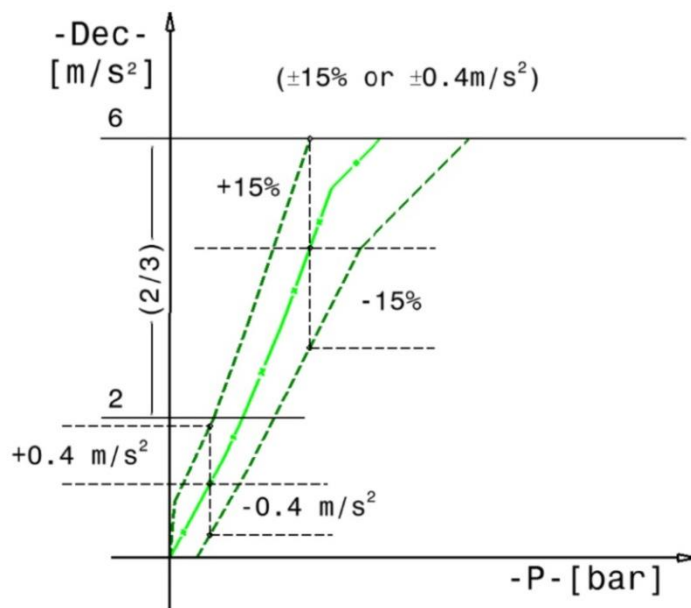
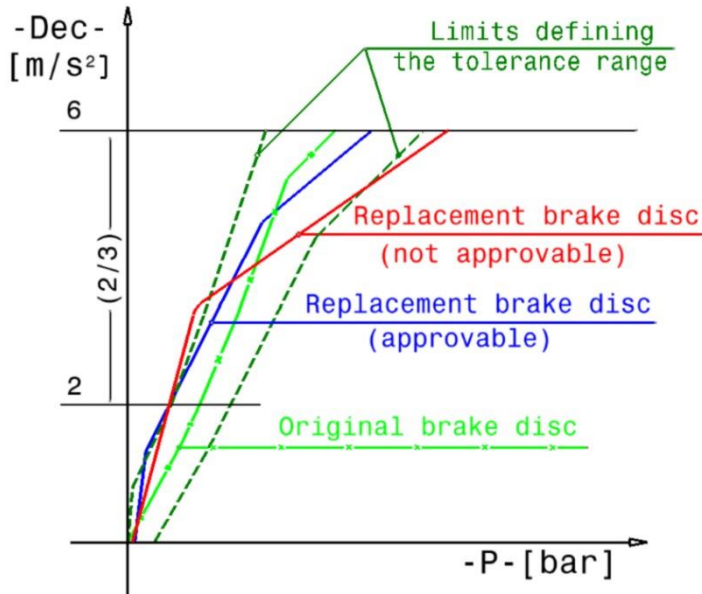

Figure 4



4. Inertia dynamometer test

4.1. Equipping the dynamometer

For testing purposes, the dynamometer shall be fitted out with the original brake caliper. The inertia dynamometer shall be equipped with a constant torque device and equipment for recording rotational speed, brake pressure, the number of revolutions after braking has commenced, brake torque, the braking period and the temperature of the brake discs on a continuous basis.

4.2. Test conditions

4.2.1. Inertia mass of the inertia dynamometer

The inertia mass of the inertia dynamometer shall be set as close as possible, with a permissible variation of ± 5 per cent, to the theoretically required value which corresponds to that part of the total inertia of the vehicle braked by the appropriate wheel. The formula used for calculation purposes is as follows:

$$I = m \cdot r_{\text{dyn}}^2$$

Where:

I = rotary inertia (kgm^2);

r_{dyn} = dynamic rolling radius of the tyre (m);

m = test mass (part of the maximum mass of the vehicle braked by the appropriate wheel) as stipulated by this Regulation.

4.2.1.1. Dynamic rolling radius

In calculating the inertia mass, the dynamic rolling radius (r_{dyn}) of the largest tyre authorised for the vehicle shall be taken into account.

4.2.1.2. Test mass

The test mass for calculating the inertia mass shall be as follows:

- (a) When testing front wheel brake disc:
 $m = x \cdot m_{veh}$ $m_{veh} = \text{max. permitted mass of the vehicle}$
- (b) When testing rear wheel brake disc:
 $m = y \cdot m_{veh}$ $m_{veh} = \text{max. permitted mass of the vehicle}$

Table A14/4.2.1.2.

| Vehicle category | Percentage by mass <i>m</i> to be taken into account | | |
|--------------------|--|--|-----------------------------|
| | <i>X</i> values (front wheel with 1 disc) | <i>X</i> values (front wheel with 2 discs) | <i>Y</i> values (rear axle) |
| L1, L2, L3, L4, L5 | 75 | 37.5 | 50 |

- 4.2.2. The initial rotational speed of the dynamometer shall correspond to the linear speed of the vehicle at 80 km/h (L₃, L₄, L₅) or 40 km/h (L₁, L₂) based on the mean of the dynamic rolling radii of the largest and smallest tyre of the authorised tyre sizes.
- 4.2.3. Cooling
The cooling may be carried out according to the test requirements specified in the following Tables A14.
- 4.2.4. Preparation of the brake
- 4.2.4.1. Disc brakes
The test is conducted using a new disc with new brake lining assemblies which have been type approved according to Regulation Nos. 78 or 90 (in the condition as mounted on the vehicle).
- 4.3. Alternative dynamometer performance test
- 4.3.1. Burnishing
According to Table A14/5.1.3.1.1.
- 4.4. Service braking system
- 4.4.1. Dry stop test
This test shall be carried out pursuant to Regulation No. 78, Annex 3, paragraph 3.
- 4.4.2. Heat fade test
This test is applicable to vehicle categories L₃, L₄ and L₅.
This test shall be carried out pursuant to Regulation No. 78, Annex 3, paragraph 7.
- 4.4.3. Testing the dynamic frictional properties
With cold brakes, the performance of the replacement brake disc shall be compared with the original equivalent by comparing the results of the test below.

- 4.4.3.1. Using the replacement brake disc, at least six consecutive brake applications with different, gradually increasing control forces or brake pressures are carried out as part of the process up to a mean fully developed deceleration of 6 m/s². The maximum control force or line pressure have not to exceed the maximum allowed control forces or line pressure permitted for this category of vehicle, in which connection the initial speed for the testing of front or rear wheel brake disc is as per the table below:

Table A14/4.4.3.1.

| Vehicle category | Test speed in km/h | |
|--|--------------------|------------|
| | Front wheel | Rear wheel |
| L ₁ L ₂ | 30 | 30 |
| L ₃ L ₄ L ₅ | 70 | 45 |

Prior to each brake application, the initial temperature of the brake disc shall be ≤ 80 °C.

- 4.4.3.2. The brake test described in paragraph 4.4.3.1. also shall be carried out using the original brake disc.
- 4.4.3.3. The dynamic frictional properties of the replacement brake disc can be regarded as similar to those of the original brake disc, provided the values attained in relation to the mean fully developed deceleration at the same operating pressures or control forces in the region of the upper 2/3 of the curve generated do not deviate by either ± 15 per cent or ± 0.4 m/s² from those of the original brake disc (see an example of the curve in Figure 3 and Figure 4 of Annex 14).
5. Integrity test using an inertia dynamometer

The tests are conducted in accordance with paragraph 5.1. (discs).

A single test per test group is required unless the replacement part does not achieve the required number of cycles before damage or failure (see paragraph 5.1.1.1.3. or 5.1.1.2.3. of this annex).

The brake should be installed on the dynamometer in accordance with its fitting position on the vehicle (rigidly mounted brake or this installed by means of a stub axle are exempt).

The temperature of the brake disc should be measured in as close proximity to the friction rubbing surface as possible. The temperature measurement should be recorded and the method and measuring point shall be the same for all tests.

If cooling air is used during a brake application or between brake applications inside one braking cycle, the speed of the airflow at the brake shall be limited to $v_{\text{air}} = 0.33 v$

Where:

v = vehicle test speed at initiation of braking.

In other cases cooling air is not restricted.

The temperature of the cooling air shall be the ambient temperature.

5.1. Brake disc thermal fatigue test

This test is conducted using a new disc, an original brake caliper of the vehicle(s) concerned and new brake lining assemblies of the vehicle(s) concerned which have been type approved according to Regulations Nos. 78 or 90 (in the condition as mounted on the vehicle).

Worn brake linings may be replaced during the test if necessary.

5.1.1. This test is applicable to vehicle categories L₃, L₄ and L₅.

5.1.2. Test conditions

The inertia mass of the inertia dynamometer shall be determined in accordance with the requirements laid down in paragraphs 4.2.1., 4.2.1.1. and 4.2.1.2. of Annex 14.

The rotational speed of the dynamometer shall correspond to the linear test speed of the vehicle based on the mean of the largest and smallest dynamic rolling radius of the tyres authorized for that vehicle.

5.1.3. Front disc

5.1.3.1. Test programme

5.1.3.1.1. Burnishing

According to Table A14/5.1.3.1.1.

Table A14/5.1.3.1.1.

| <i>Burnishing</i> | | | | | | | |
|-------------------|----------------------------------|-----------------------------|---------------------------|---------------------------------------|---|--------------------------------|--|
| <i>Step</i> | <i>Vehicle gross weight [kg]</i> | <i>Initial speed [km/h]</i> | <i>Final speed [km/h]</i> | <i>Deceleration [m/s²]</i> | <i>Starting temperature before the braking [°C] MAX</i> | <i>Brakings quantity [---]</i> | <i>Max speed of the permitted airflow during the brake application [m/s]</i> |
| 1 | 75% / disc q.ty | 80 | 30 | 4 | 100 | 60 | 30 |

5.1.3.1.2. Fatigue test

According to Table A14/5.1.3.1.2.

Table A14/5.1.3.1.2.

| <i>Thermal fatigue test</i> | | | | | | | | |
|-----------------------------|----------------------------------|-----------------------------|---------------------------|---------------------------------------|--|--|--------------------------------|--|
| <i>Step</i> | <i>Vehicle gross weight [kg]</i> | <i>Initial speed [km/h]</i> | <i>Final speed [km/h]</i> | <i>Deceleration [m/s²]</i> | <i>Starting temperature before the brakings [°C] +/- 10 °C</i> | <i>Time between 2 consecutive brakings [s]</i> | <i>Brakings quantity [---]</i> | <i>Max speed of the permitted airflow during the brake application [m/s]</i> |
| 1 thermal | 75% / discs q.ty | 50% Vmax | 5 | 7 | 100 (a) | 30 | 5 | 20 |

| <i>Thermal fatigue test</i> | | | | | | | | |
|-----------------------------|----------------------------------|-----------------------------|---------------------------|---------------------------------------|--|--|--------------------------------|--|
| <i>Step</i> | <i>Vehicle gross weight [kg]</i> | <i>Initial speed [km/h]</i> | <i>Final speed [km/h]</i> | <i>Deceleration [m/s²]</i> | <i>Starting temperature before the brakings [°C] +/- 10 °C</i> | <i>Time between 2 consecutive brakings [s]</i> | <i>Brakings quantity [---]</i> | <i>Max speed of the permitted airflow during the brake application [m/s]</i> |
| 2 functional | 75% / discs q.ty | 80% Vmax | 5 | 8 | 200 | --- | 1 | 30 |
| 3 mechanic | 100% / discs q.ty | 60% Vmax | 5 | 10 | 200 | --- | 2 | 30 |

Steps from 1 to 3 = 1 cycle; repeating for a total of 20 cycles (= 160 brakings)

(a) Starting temperature of the 1st braking only

(b) In case of early wear of the friction material of the pads, the use of another pads set is allowed; in this case, before completing the test, the new pads set must be burnished according to paragraph 5.1.3.1.1, always using the brake disc under test.

5.1.4. Rear disc

5.1.4.1. Test program

5.1.4.1.1. Burnishing

According to Table A14/5.1.4.1.1.

Table A14/5.1.4.1.1.

| <i>Burnishing</i> | | | | | | | |
|-------------------|----------------------------------|-----------------------------|---------------------------|---------------------------------------|--|--------------------------------|--|
| <i>Step</i> | <i>Vehicle gross weight [kg]</i> | <i>Initial speed [km/h]</i> | <i>Final speed [km/h]</i> | <i>Deceleration [m/s²]</i> | <i>Starting temperature before the brakings [°C] MAX</i> | <i>Brakings quantity [---]</i> | <i>Max speed of the permitted airflow during the brake application [m/s]</i> |
| 1 | 50% | 60 | 30 | 2 | 100 | 60 | 30 |

5.1.4.1.2. Fade test

According to Table A14/5.1.4.1.2.

Table A14/5.1.4.1.2.

| <i>Fade test</i> | | | | | | | | |
|------------------|----------------------------------|-----------------------------|---------------------------|---------------------------------------|---|--|--------------------------------|--|
| <i>Step</i> | <i>Vehicle gross weight [kg]</i> | <i>Initial speed [km/h]</i> | <i>Final speed [km/h]</i> | <i>Deceleration [m/s²]</i> | <i>Starting temperature before the first braking [°C] MAX</i> | <i>Time between 2 consecutive brakings [s]</i> | <i>Brakings quantity [---]</i> | <i>Max speed of the permitted airflow during the brake application [m/s]</i> |
| 1 | 50% | 40% Vmax | 20% Vmax | 2 | 100 | 30 | 15 | 10 |

5.1.4.1.3. Fatigue test

According to Table A14/5.1.4.1.3.

Table A14/5.1.4.1.3.

| <i>Thermal fatigue test</i> | | | | | | | | |
|--|----------------------------------|-----------------------------|---------------------------|---------------------------------------|--|--|--------------------------------|--|
| <i>Step</i> | <i>Vehicle gross weight [kg]</i> | <i>Initial speed [km/h]</i> | <i>Final speed [km/h]</i> | <i>Deceleration [m/s²]</i> | <i>Starting temperature before the braking [°C] +/- 10°C</i> | <i>Time between 2 consecutive brakings [s]</i> | <i>Brakings quantity [---]</i> | <i>Max speed of the permitted airflow during the brake application [m/s]</i> |
| 1 thermal | 50% | 40% Vmax | 20% Vmax | 3 | 100 ^(a) | 30 | 5 | 20 |
| 2 functional | 50% | 50% Vmax ^(b) | 5 | 4 | 200 | --- | 1 | 30 |
| | | 60% Vmax ^(c) | | | | | | |
| | | 75% Vmax ^(d) | | | | | | |
| 3 mechanic | 90% | 40% Vmax ^(b) | 5 | 5 | 200 | --- | 2 | 30 |
| | | 48% Vmax ^(c) | | | | | | |
| | | 60% Vmax ^(d) | | | | | | |
| Steps from 1 to 3 = 1 cycle; repeating for a total of 20 cycles (= 160 brakings) | | | | | | | | |

(a) Starting temperature of the 1st braking only

(b) Disc diameter ≤ 245 mm

(c) Disc diameter > 245 < 280 mm

(d) Disc diameter ≥ 280 mm

(e) In case of early wear of the friction material of the pads, the use of another pads set is allowed; in this case, before completing the test, the new pads set must be burnished according to paragraphs 5.1.4.1.1. – 5.1.4.1.2., always using the brake disc under test.

5.1.5. Test result (brake disc thermal fatigue test)

The test is regarded as having been passed if the cycles prescribed in:

(a) Tables A14/5.1.3.1.1. – 5.1.3.1.2. for front discs

(b) Tables A14/5.1.4.1.1. – 5.1.4.1.2. - 5.1.4.1.3. for rear discs

are completed without damage or failure.

If less than 20 cycles, according to "Thermomechanical Fatigue test" in Tables A14/5.1.3.1.2. and A14/5.1.4.1.3., but more than 15 are completed without damage or failure, then the test must be repeated on a new replacement part.

Under these circumstances both tests must complete more than 15 cycles without damage or failure for the part to have passed the test.

If less than 15 cycles are completed before damage or failure, then a test should be conducted on the original part and the results compared.

If the damage or failure point is no worse than the quantity of cycles of the original part – 10 per cent, then the test is regarded as having been passed.

Damage or failure, in this context, means:

- 5.1.5.1. During the test:
Temperature exceeds 600 °C.
- 5.1.5.2. After the test:
- (a) Contact between caliper and disc;
 - (b) Cracks, permanent deformation or breakings;
 - (c) Abnormal wear;
 - (d) A 0.150 mm maximum increasing of run-out, compared to the initial value measured before the test, is allowed;
 - (e) A 0.250 mm maximum run-out is allowed;
 - (f) A 0.100 mm maximum (for "full floating" disc) straightness increasing, compared to the initial value measured before the test, is allowed."

Add a new Annex 15, to read:

"Annex 15

Criteria for groups of discs for vehicles of categories L₁, L₂, L₃, L₄ and L₅

1. Definition of the disc braking surface width
Braking surface means the surface of a brake disc on which the brake pads work. The braking surface width is calculated between the disc outer diameter and an internal diameter defined as follows:
 - 1.1. Case of braking surface with lightening (holes, slots, wave, etc.) on the braking surface (Figure 1) only: 3 mm towards the centre of the disc from the end of the lightening.
 - 1.2. Case of braking surface with lightening (holes, slots, wave, etc.) with distance from the disc's internal diameter lower than 5 mm (Figure 2): diameter of the brake disc undercut.
 - 1.3. Case of braking surface with lightening (holes, slots, wave, etc.) which terminate inside, outside the brake disc undercut (Figure 3): diameter of the brake disc internal undercut.
 - 1.4. All other cases: internal diameter defined by the radial width of the largest combinable pad, to which 3 mm need to be added (Figure 4).

Figure 1

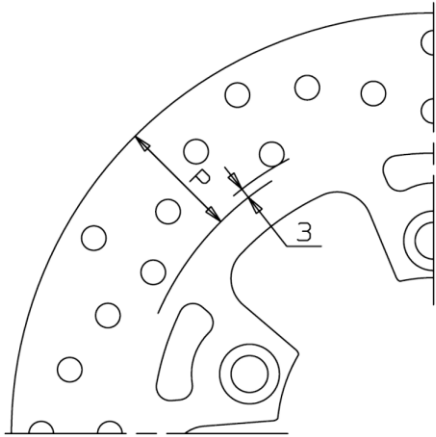

Figure 2

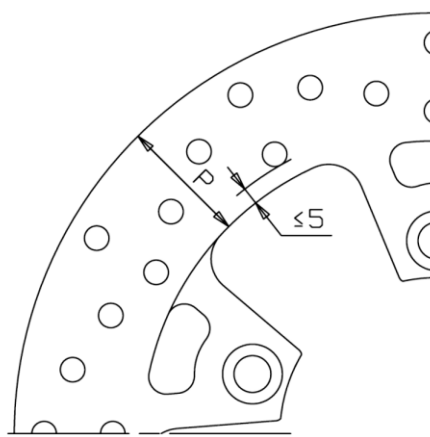

Figure 3

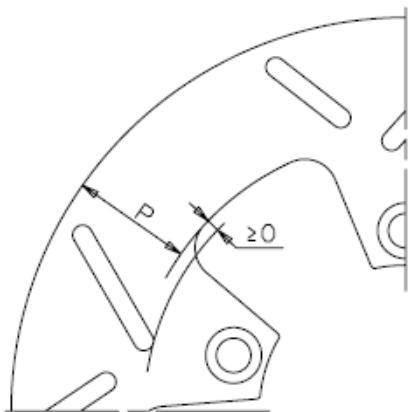
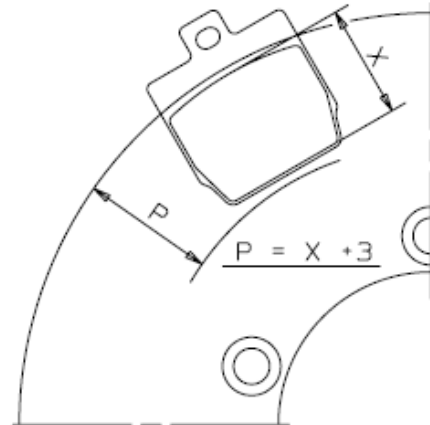
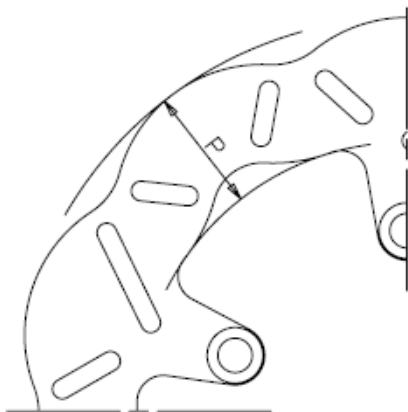

Figure 4



2. Groups of discs

"Group of discs" means a grouping of similar discs, so that the tests performed on a single disc are considered valid for the entire group of similar discs.

Discs belonging to the same group must have following features, as indicated at following paragraphs from 2.1. to 2.9.

For a given group of discs, the approval tests may be performed on one disc, belonging to the group, subjected to the highest braking torque and to the largest energy to be absorbed.

The similarity between the discs is defined by following grouping criteria, that must be simultaneously fulfilled:

- 2.1. Same type of the reference disc for that group (one piece, composed fixed or floating).
- 2.2. Braking surface material to be chosen among those listed at paragraph 5.3.3.2.2.; other materials can be used provided that, under approval, they are declared with equal demonstration of test results according to paragraph 8. In this case, the

extension applies to all groups listed in Table 3 for dimensions equal or lower to that demonstrated.

2.3. Braking surface lightening: any solution is allowed (holes, slots, wave, etc.) provided that:

2.3.1. For discs having the same diameter and thickness: the mass change of the braking surface swept by the pads must be within the range of ± 20 per cent with respect to the reference disc.

2.3.2. All other cases: the ratio between the area of the disc braking surface, as defined in paragraph 4., and the lightening area (sum of the area of holes, slots, etc.) must match those of the reference disc, with tolerance of $- 20$ per cent maximum.

Examples:

R reference disc, \varnothing 300 mm:

Outer diameter 300 mm, radial width of the braking surface 36.5 mm \geq total area
 $A = 302 \text{ cm}^2$

Lightening on the braking surface: 64 holes diameter 7 mm \geq total area

$B = 24.6 \text{ cm}^2$

A/B ratio = 12.3

S disc \varnothing 285:

Outer diameter 285 mm, radial width of the braking surface 41 mm \geq total area
 $A = 314 \text{ cm}^2$

Lightening on the braking surface: 60 holes diameter 7 mm \geq total area

$B = 23 \text{ cm}^2$

A/B ratio = 13.7

S disc may belong to the same group of R reference disc, as the 13,7 ratio is greater than the 12, ratio of R disc.

T disc \varnothing 260:

Outer diameter 260 mm, radial width of the braking surface 29 mm \geq total area
 $A = 210 \text{ cm}^2$

Lightening on the braking surface: 64 holes diameter 7 mm \geq total area

$B = 24.6 \text{ cm}^2$

A/B ratio = 8.5

T disc may not belong to the same group of R reference disc as the 8.5 ratio,

$- 31$ per cent with respect to the 12.3 ratio of R disc, therefore over the specified tolerance of $- 20$ per cent maximum.

2.4. Same material and mechanical properties, as specified in the international standard for materials, or higher, for the bell.

In the case of disc with steel bell, compared with the disc tested for approval with aluminium bell, the exception of belonging to the same group is allowed; the reverse is not allowed.

- 2.5. Same material and mechanical properties, as specified in the international standard for materials, or higher, for the bell/braking surface fasteners.
- 2.6. Spokes of the bell with full/empty ratio – measured on the average circumference between end of the mounting face and beginning of the braking surface – within the range ± 20 per cent, thickness within the range (+ 30 per cent) \div (– 10 per cent) and same mechanical properties, as specified in the international standard for materials, with respect to the reference disc.
- 2.7. Same technical solution for the bell-braking surface fasteners (same drawing and materials; for the quantity of bell-braking surface fasteners, permitted the same quantity with a tolerance of +2 –0).
- 2.8. The quantity of fixing holes is not binding by group belonging, in order to ensure interchangeability with original disc.
- 2.9. Outer diameter included in the range of 50 mm, according to Table 2.9.:

Table A15/2.9.

| <i>Range [mm]</i> | <i>One piece</i> | <i>Composite fixed</i> | <i>Floating discs</i> |
|-----------------------|------------------|----------------------------|-----------------------|
| $\geq 150 < 200$ | X | X | X |
| $\geq 200 < 250$ | X | X | X |
| $\geq 250 < 300$ | X | X | X |
| $\geq 300 < 350$ | X | X | X |

There are no groups for "peripheral" discs (fitted on the wheel outer diameter).

Note:

For new applications that will be included into an existing group, an increase of 10 per cent maximum kinetic energy is allowed with reference to the value used for the approval of the disc of the reference group.

Data for the new calculation of kinetic energy must be traced from the product data sheet issued by the vehicle manufacturer.

In the case of discs with applications on both wheels, front and rear, the approval tests at paragraph 8. shall be conducted on heaviest application."