

5 February 2016

---

## **Agreement**

### **Concerning the Adoption of Uniform Technical Prescriptions for Wheeled Vehicles, Equipment and Parts which can be Fitted and/or be Used on Wheeled Vehicles and the Conditions for Reciprocal Recognition of Approvals Granted on the Basis of these Prescriptions\***

(Revision 2, including the amendments which entered into force on 16 October 1995)

---

## **Addendum 134 – Regulation No. 135**

### **Revision 1**

Incorporating all valid text up to:

Date of entry into force as an annex to the 1958 Agreement: 15 June 2015

Supplement 1 to the original version of the Regulation - Date of entry into force: 29 January 2016

01 series of amendments to the Regulation – Date of entry into force: 20 January 2016

### **Uniform provisions concerning the approval of vehicles with regard to their Pole Side Impact performance (PSI)**

This document is meant purely as documentation tool. The authentic and legal binding texts are:

- ECE/TRANS/WP.29/2014/79
- ECE/TRANS/WP.29/2015/54 and
- ECE/TRANS/WP.29/2014/80.



**UNITED NATIONS**

---

\* Former title of the Agreement: Agreement Concerning the Adoption of Uniform Conditions of Approval and Reciprocal Recognition of Approval for Motor Vehicle Equipment and Parts, done at Geneva on 20 March 1958.



## Regulation No. 135

### Uniform provisions concerning the approval of vehicles with regard to their Pole Side Impact performance (PSI)

#### Contents

	<i>Page</i>
Regulation	
1. Scope .....	4
2. Definitions.....	4
3. Application for approval .....	7
4. Approval .....	8
5. Requirements.....	9
6. Modification of the vehicle type and extension of approval .....	11
7. Conformity of production.....	12
8. Penalties for non-conformity of production .....	12
9. Production definitively discontinued.....	12
10. Names and addresses of Technical Services responsible for conducting approval tests, and of Type Approval Authorities .....	12
Annexes	
1 Communication .....	14
2 Arrangement of the approval mark .....	16
3 Dynamic pole side impact test procedure.....	17
4 Seat adjustment and installation requirements for the WorldSID 50th percentile adult male dummy .....	22
5 Description of the three-dimensional H-point machine (3-D H machine) .....	32
6 Test conditions and procedures for the assessment of post-crash hydrogen fuel system integrity ...	35
7 Impact reference line .....	39
8 Impact angle .....	40
9 Pitch and roll angle references .....	41
10 Determination of WorldSID 50th percentile adult male performance criteria .....	42

## 1. Scope<sup>1</sup>

1.1. This Regulation applies to:

- (a) Category M<sub>1</sub> vehicles with a gross vehicle mass of up to 3,500 kg; and
- (b) Category N<sub>1</sub> vehicles where the acute angle alpha ( $\alpha$ ), measured between a horizontal plane passing through the centre of the front axle and an angular transverse plane passing through the centre of the front axle and the R-point of the driver's seat, as illustrated below, is less than 22.0 degrees; or the ratio between the distance from the driver's R-point to the centre of the rear axle (L101-L114) and the centre of the front axle and the driver's R-point (L114) is less than 1.30.<sup>2</sup>

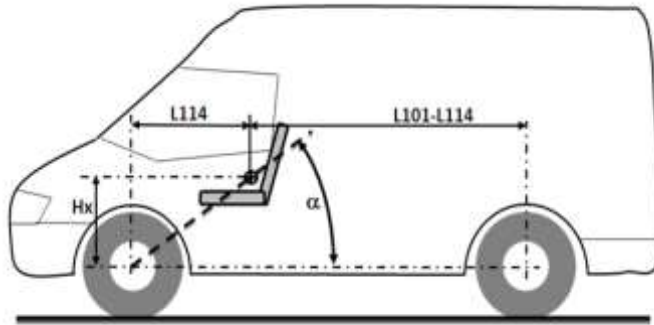

1.2. Other Category M and Category N vehicles with a gross vehicle mass of up to 4,500 kg may also be approved if requested by the manufacturer.

## 2. Definitions

For the purposes of this Regulation:

- 2.1. "Approval of a vehicle type" means the full procedure whereby a Contracting Party to the Agreement applying this Regulation certifies that a vehicle type meets the technical requirements of this Regulation.
- 2.2. "Back Door" is a door or door system on the back end of a motor vehicle through which passengers can enter or depart the vehicle or cargo can be loaded or unloaded. It does not include:

---

<sup>1</sup> In accordance with the general guidelines on the scope of UN Regulations (see document ECE/TRANS/WP.29/1044/Rev.1), Regulation No. 135 type approvals may only be granted for vehicles within the scope of this Regulation and shall be accepted by all the Contracting Parties applying this Regulation. However, decisions regarding the vehicle categories required on a regional/national basis to meet the requirements of this Regulation shall be dealt with at the regional/national level. A Contracting Party may therefore restrict application of the requirements in its national legislation if it decides that such restriction is appropriate.

<sup>2</sup> As defined in the Consolidated Resolution on the Construction of Vehicles (R.E.3.), document ECE/TRANS/WP.29/78/Rev.3, para. 2 - [www.unece.org/trans/main/wp29/wp29wgs/wp29gen/wp29resolutions.html](http://www.unece.org/trans/main/wp29/wp29wgs/wp29gen/wp29resolutions.html)

- (a) A trunk lid; or
  - (b) A door or window that is composed entirely of glazing material and whose latches and/or hinge systems are attached directly to the glazing material.
- 2.3. "*Compressed hydrogen storage system (CHSS)*" means a system designed to store hydrogen fuel for a hydrogen-fuelled vehicle and composed of a pressurized container, pressure relief devices (PRDs) and shut off device that isolate the stored hydrogen from the remainder of the fuel system and the environment.
- 2.4. "*Container (for hydrogen storage)*" means the component within the hydrogen storage system that stores the primary volume of hydrogen fuel.
- 2.5. "*Door latch system*" consists, at a minimum, of a latch and a striker.
- 2.6. "*Fuel ballast leakage*" means the fall, flow, or run of fuel ballast from the vehicle but does not include wetness resulting from capillary action.
- 2.7. "*Fully latched position*" is the coupling condition of the latch that retains the door in a completely closed position.
- 2.8. "*Gross vehicle mass*" means the maximum mass of the fully laden solo vehicle, based on its construction and design performances, as declared by the manufacturer.
- 2.9. "*Hinge*" is a device used to position the door relative to the body structure and control the path of the door swing for passenger ingress and egress.
- 2.10. "*Hydrogen-fuelled vehicle*" means any motor vehicle that uses compressed gaseous hydrogen as a fuel to propel the vehicle, including fuel cell and internal combustion engine vehicles. Hydrogen fuel for passenger vehicles is specified in ISO 14687-2:2012 and SAE J2719 (Sep 2011 Revision).
- 2.11. "*Latch*" is a device employed to maintain the door in a closed position relative to the vehicle body with provisions for deliberate release (or operation).
- 2.12. "*Latched*" means any coupling condition of the door latch system, where the latch is in a fully latched position, a secondary latched position, or between a fully latched position and a secondary latched position.
- 2.13. "*Manufacturer*" means the person or body responsible to the Approval Authority for all aspects of the type approval process and for ensuring conformity of production. It is not essential that the person or body is directly involved in all stages of the construction of the vehicle, system or component which is the subject of the approval process.
- 2.14. "*Passenger compartment*" means the space for occupant accommodation, bounded by the roof, floor, side walls, doors, outside glazing and front bulkhead and the plane of the rear compartment bulkhead or the plane of the rear-seat back support.
- 2.15. "*Pressure relief device (PRD) (for hydrogen storage systems)*" means a device that, when activated under specified performance conditions, is used to release hydrogen from a pressurised system and thereby prevent failure of the system.
- 2.16. "*Rated cargo and luggage mass*" means the cargo and luggage carrying capacity of the vehicle, which is the mass obtained by subtracting the unladen vehicle mass and the rated occupant mass from the gross vehicle mass.

- 2.17. "*Rated occupant mass*" is the mass obtained by multiplying the total number of designated seating positions in the vehicle by 68 kg.
- 2.18. "*R-point*" means a design reference point, which:
- (a) Has coordinates determined in relation to the designed vehicle structure; and
  - (b) Shall be established, where relevant for the purpose of this Regulation, in accordance with Annex 1 of the Consolidated Resolution on the Construction of Vehicles (R.E.3).<sup>3</sup>
- 2.19. "*Secondary latched position*" refers to the coupling condition of the latch that retains the door in a partially closed position.
- 2.20. "*Shut-off valve (for hydrogen-fuelled vehicles)*" means a valve between the storage container and the vehicle fuel system that can be automatically activated; which defaults to the "closed" position when not connected to a power source.
- 2.21. "*Striker*" is a device with which the latch engages to maintain the door in the fully latched or secondary latched position.
- 2.22. "*Trunk lid*" is a movable body panel that provides access from outside the vehicle to a space wholly partitioned from the passenger compartment by a permanently attached partition or fixed or fold-down seat back (in the position of occupant use).
- 2.23. "*Type of protective system*" means a category of protective devices which do not differ in such essential design respects as their:
- (a) Technology;
  - (b) Geometry;
  - (c) Energy-absorption capacity; and
  - (d) Constituent materials.
- 2.24. "*Unladen vehicle mass*" means the nominal mass of a complete vehicle with bodywork and all factory fitted equipment, electrical and auxiliary equipment for normal operation of the vehicle, including liquids, tools, fire extinguisher, standard spare parts, chocks and spare wheel, if fitted. The fuel tank is filled to 90 per cent of manufacturer rated capacity and the other liquid containing systems (except those for used water) to 100 per cent of the capacity specified by the manufacturer.
- 2.25. "*Vehicle fuel system (for hydrogen-fuelled vehicles)*" means an assembly of components used to store or supply hydrogen fuel to a fuel cell (FC) or internal combustion engine (ICE).
- 2.26. "*Vehicle type*" means a category of vehicles, the design characteristics of which do not differ in such essential respects as:
- (a) The type of protective system(s);
  - (b) The type of front seat(s);
  - (c) The vehicle width;

---

<sup>3</sup> Document ECE/TRANS/WP.29/78/Rev.3, Annex 1 -  
[www.unece.org/trans/main/wp29/wp29wgs/wp29gen/wp29resolutions.html](http://www.unece.org/trans/main/wp29/wp29wgs/wp29gen/wp29resolutions.html)

- (d) The wheelbase and overall length of the vehicle;
- (e) The structure, dimensions, lines and materials of the side walls of the passenger compartment, including any optional arrangements or interior fittings within or about the side walls of the passenger compartment;
- (f) The type of door latches and hinges;
- (g) The type of fuel system(s);
- (h) The unladen vehicle mass and the rated cargo and luggage mass;
- (i) The sitting of the engine (front, rear or centre);

in so far as they may be considered to have a negative effect on the results of a vehicle-to-pole side impact test conducted in accordance with Annex 3 of this Regulation.

- 2.27. "*Vehicle width*" means the distance between two planes parallel to the longitudinal median plane (of the vehicle) and touching the vehicle on either side of the said plane but excluding the rear-view mirrors, side marker lamps, tyre pressure indicators, direction indicator lamps, position lamps, flexible mud-guards and the deflected part of the tyre side-walls immediately above the point of contact with the ground.

### **3. Application for approval**

- 3.1. The application for approval of a vehicle type with regard to its pole side impact performance shall be submitted by the vehicle manufacturer or their duly accredited representative.
- 3.2. It shall be accompanied by the undermentioned documents in triplicate and the following particulars:
  - 3.2.1. A detailed description of the vehicle type with respect to its structure, dimensions, lines and constituent materials;
  - 3.2.2. Photographs and/or diagrams and drawings of the vehicle showing the vehicle type in front, side and rear elevation and design details of the lateral part of the structure;
  - 3.2.3. Unladen vehicle mass, rated cargo and luggage mass, and gross vehicle mass specifications for the vehicle type;
  - 3.2.4. The lines and inside dimensions of the passenger compartment; and
  - 3.2.5. A description of the relevant side interior fittings and protective systems installed in the vehicle.
- 3.3. The applicant for approval shall be entitled to present any data and results of tests carried out which make it possible to establish that compliance with the requirements can be achieved on prototype vehicles with a sufficient degree of accuracy.
- 3.4. A vehicle which is representative of the vehicle type to be approved shall be submitted to the Technical Service responsible for conducting the approval test(s).

- 3.4.1. A vehicle not comprising all the components proper to the vehicle type may be accepted for tests provided that it can be shown that the absence of the components omitted has no detrimental effect on the performance prescribed in the requirements of this Regulation.
- 3.4.2. It shall be the responsibility of the applicant for approval to show that the application of paragraph 3.4.1. is in compliance with the requirements of this Regulation.

## **4. Approval**

- 4.1. If the vehicle type submitted for approval pursuant to this Regulation meets the requirements of paragraph 5 below, approval of that vehicle type shall be granted.
- 4.2. In case of doubt, account shall be taken, when verifying the conformity of the vehicle to the requirements of this Regulation, of any data or test results provided by the manufacturer which can be taken into consideration in validating the approval test carried out by the Technical Service.
- 4.3. An approval number shall be assigned to each vehicle type approved. Its first two digits (at present 01 corresponding to the 01 series of amendments) shall indicate the series of amendments incorporating the most recent major technical amendments made to the Regulation at the time of issue of the approval. The same Contracting Party may not assign the same approval number to another vehicle type.
- 4.4. Notice of approval or of extension or of refusal or withdrawal of approval pursuant to this Regulation shall be communicated to the Contracting Parties to the Agreement applying this Regulation by means of a form conforming to the model in Annex 1 of this Regulation and photographs and/or diagrams and drawings supplied by the applicant for approval, in a format not exceeding A4 (210 x 297) mm or folded to that format and on an appropriate scale.
- 4.5. There shall be affixed to every vehicle conforming to a vehicle type approved under this Regulation, conspicuously and in a readily accessible place specified on the approval form, an international approval mark consisting of:
- 4.5.1. A circle surrounding the letter "E" followed by the distinguishing number of the country which has granted approval;<sup>4</sup>
- 4.5.2. The number of this Regulation, followed by the letter "R", a dash and the approval number, to the right of the circle prescribed in paragraph 4.5.1.
- 4.6. If the vehicle conforms to a vehicle type approved, under one or more other Regulations annexed to the Agreement, in the country which has granted approval under this Regulation, the symbol prescribed in paragraph 4.5.1. need not be repeated; in this case the Regulation and approval numbers and the additional symbols of all the Regulations under which approval has been

---

<sup>4</sup> The distinguishing numbers of the Contracting Parties to the 1958 Agreement are reproduced in Annex 3 to the Consolidated Resolution on the Construction of Vehicles (R.E.3), document ECE/TRANS/WP.29/78/Rev. 3, Annex 3 - [www.unece.org/trans/main/wp29/wp29wgs/wp29gen/wp29resolutions.html](http://www.unece.org/trans/main/wp29/wp29wgs/wp29gen/wp29resolutions.html)



granted in the country which has granted approval under this Regulation shall be placed in vertical columns to the right of the symbol prescribed in paragraph 4.5.1.

- 4.7. The approval mark shall be clearly legible and shall be indelible.
- 4.8. The approval mark shall be placed close to or on the vehicle data plate affixed by the manufacturer.
- 4.9. Annex 2 to this Regulation gives examples of approval marks.

## **5. Requirements**

- 5.1. A vehicle, representative of the vehicle type to be approved, shall be tested in accordance with Annex 3, using a WorldSID 50<sup>th</sup> percentile adult male dummy.<sup>5</sup>
  - 5.1.1. With the exception of vehicle types designed as described in paragraph 5.1.2. below, the approval test shall be conducted such that the vehicle impacts the pole on the driver's side.
  - 5.1.2. In the case of vehicle types where the side structures, front-row seats or the type of protective systems on each side of the vehicle are sufficiently different for the Approval Authority to consider they could appreciably affect performance in a test conducted in accordance with Annex 3; either of the alternatives in paragraph 5.1.2.1. or 5.1.2.2. may be used by the Approval Authority.
    - 5.1.2.1. The Approval Authority will require the approval test to be conducted such that the vehicle impacts the pole on the driver's side where:
      - 5.1.2.1.1. This is considered the least favourable side; or
      - 5.1.2.1.2. The manufacturer provides additional information (e.g. manufacturer's in-house test data) sufficient to satisfy the Approval Authority that the design differences on each side of the vehicle do not appreciably affect performance in a test conducted in accordance with Annex 3.
    - 5.1.2.2. The Approval Authority will require the approval test to be conducted such that the vehicle impacts the pole on the side opposite the driver's side, where this is considered the least favourable side.
- 5.2. The results of an approval test conducted in accordance with paragraph 5.1. shall be considered satisfactory, if the requirements of paragraphs 5.3., 5.4. and 5.5. are met.
- 5.3. WorldSID 50<sup>th</sup> percentile adult male performance requirements
  - 5.3.1. The performance criteria measured by a WorldSID 50<sup>th</sup> percentile adult male dummy in the front-row outboard seating position on the impact side of a vehicle tested in accordance with Annex 3, shall meet the requirements of paragraphs 5.3.2. to 5.3.6.

---

<sup>5</sup> The technical specifications, including detailed drawings and procedures for assembly/disassembly of the WorldSID 50<sup>th</sup> percentile adult male dummy are specified by reference in Annex 3 of this Regulation.

- 5.3.2. Head Injury Criteria
  - 5.3.2.1 The Head Injury Criterion (HIC) 36 shall not exceed 1,000 when calculated in accordance with paragraph 1. of Annex 10.
- 5.3.3. Shoulder performance criteria
  - 5.3.3.1. The peak lateral shoulder force shall not exceed 3.0 kN when calculated in accordance with paragraph 2.1. of Annex 10.
- 5.3.4. Thorax performance criteria
  - 5.3.4.1 The maximum thorax rib deflection shall not exceed 55 mm when calculated in accordance with paragraph 3.1. of Annex 10.
- 5.3.5. Abdominal performance criteria
  - 5.3.5.1. The maximum abdominal rib deflection shall not exceed 65 mm when calculated in accordance with paragraph 4.1. of Annex 10.
  - 5.3.5.2. The resultant lower spine acceleration shall not exceed 75 g (1 g = the acceleration due to gravity = 9.81 m/s<sup>2</sup>), except for intervals whose cumulative duration is not more than 3ms, when calculated in accordance with paragraph 4.2. of Annex 10.
- 5.3.6. Pelvis performance criteria
  - 5.3.6.1. The peak pubic symphysis force shall not exceed 3.36 kN when calculated in accordance with paragraph 5.1. of Annex 10.
- 5.4. Door latch and hinge system integrity requirements
  - 5.4.1. Any side door which impacts the pole shall not separate totally from the vehicle.
  - 5.4.2. Any door (including a back door, but excluding a trunk lid), which does not impact the pole and is not wholly partitioned from the passenger compartment by a permanently attached partition or fixed or fold-down seat back (in the position of occupant use), shall meet the following requirements:
    - 5.4.2.1. The door shall remain latched;
    - 5.4.2.2. The latch shall not separate from the striker;
    - 5.4.2.3. The hinge components shall not separate from each other or from their attachment to the vehicle; and
    - 5.4.2.4. Neither the latch nor the hinge systems of the door shall pull out of their anchorages.
- 5.5. Fuel system integrity requirements
  - 5.5.1. In the case of a vehicle propelled by fuel with a boiling point above 0 °C, fuel ballast leakage from the fuel system(s)<sup>6</sup> prepared in accordance with paragraph 5.1. of Annex 3 shall not exceed:
    - 5.5.1.1. A total of 142 grams during the 5 minute period immediately following first vehicle contact with the pole; and

---

<sup>6</sup> To ensure that liquid leakage from the fuel system can be easily separated and identified, liquids from other vehicle systems may be replaced by the equivalent ballast mass (as per paragraph 5.3 of Annex 3).

- 5.5.1.2. A total of 28 grams during each subsequent 1 minute period from 5 minutes up until 30 minutes after first vehicle contact with the pole.
- 5.5.2. In the case of a compressed hydrogen-fuelled vehicle:
  - 5.5.2.1. The hydrogen leakage rate ( $V_{H_2}$ ) determined in accordance with either, paragraph 4. of Annex 6 for hydrogen, or paragraph 5. of Annex 6 for helium, shall not exceed an average of 118 NL per minute for the time interval,  $\Delta t$  minutes, after the crash;
  - 5.5.2.2. The gas (hydrogen or helium as applicable) concentration by volume in air values determined for the passenger and luggage compartments in accordance with paragraph 6. of Annex 6, shall not exceed 4.0 per cent for hydrogen or 3.0 per cent for helium, at any time throughout the 60 minute post-crash measurement period;<sup>7</sup> and
  - 5.5.2.3. The container(s) (for hydrogen storage) shall remain attached to the vehicle at a minimum of one attachment point.

## **6. Modification of the vehicle type and extension of approval**

- 6.1. Every modification, affecting the design characteristics of the vehicle type identified in paragraph 2.26. (a) to (i) above, shall be brought to the attention of the Approval Authority which approved the vehicle type. The Approval Authority may then either:
  - 6.1.1. Consider that the modifications made will not have an appreciable adverse effect on the vehicle-to-pole side impact performance and grant an extension of the approval; or
  - 6.1.2. Consider that the modifications made could adversely affect the vehicle-to-pole side impact performance and require further tests or additional checks before granting an extension of the approval.
- 6.2. Provided there is otherwise no conflict with the provisions of paragraph 6.1. above, the approval shall be extended to cover all the other variants of the vehicle type for which the sum of the unladen vehicle mass and the rated cargo and luggage mass is not more than 8 per cent greater than that of the vehicle used in the approval test.
- 6.3. A notice of extension or refusal of approval, specifying the alteration(s), shall be communicated by the Approval Authority to the other Contracting Parties to the Agreement which apply this Regulation, using the procedure specified in paragraph 4.4. above.
- 6.4. The Approval Authority shall assign a serial number to each extension, to be known as the extension number.

---

<sup>7</sup> This requirement is satisfied if it is confirmed that the shut-off valve of each hydrogen storage system has closed within 5 seconds of first vehicle contact with the pole and there is no leakage from the hydrogen storage system(s).

## **7. Conformity of production**

The conformity of production procedures shall comply with those set out in Appendix 2 of the Agreement (E/ECE/324-E/ECE/TRANS/505/Rev.2), with the following requirements.

- 7.1. Every vehicle approved under this Regulation shall be so manufactured as to conform to the type approved by meeting the requirements set out in paragraph 5. above.
- 7.2. The holder of the approval shall ensure that for each type of vehicle at least the tests concerning the taking of measurements are carried out.
- 7.3. The authority which has granted type approval may at any time verify the conformity control methods applied in each production facility. The normal frequency of these verifications shall be once every two years.

## **8. Penalties for non-conformity of production**

- 8.1. The approval granted in respect of a vehicle type, pursuant to this Regulation, may be withdrawn if the requirement laid down in paragraph 7.1. above is not complied with, or if the vehicle or vehicles selected have failed to pass the checks prescribed in paragraph 7.2. above.
- 8.2. If a Contracting Party to the Agreement applying this Regulation withdraws an approval it has previously granted, it shall forthwith so notify the other Contracting Parties applying this Regulation by means of a communication form conforming to the model in Annex 1 to this Regulation.

## **9. Production definitively discontinued**

- 9.1. If the holder of the approval completely ceases to manufacture a type of vehicle approved in accordance with this Regulation, they shall so inform the authority which granted the approval, which in turn shall forthwith notify the other Contracting Parties to the Agreement applying this Regulation by means of a communication form conforming to the model set out in Annex 1 to this Regulation.

## **10. Names and addresses of Technical Services responsible for conducting approval tests, and of Type Approval Authorities**

- 10.1. The Contracting Parties to the Agreement applying this Regulation shall communicate to the United Nations secretariat the names and addresses of the Technical Services responsible for conducting approval tests, and of the Type Approval Authority which grant approval and to which forms certifying approval or extension, or refusal or withdrawal of approval, issued in other countries, are to be sent.

## **11. Transitional provisions**

- 11.1. As from the official date of entry into force of the 01 series of amendments to this Regulation, no Contracting Party applying this Regulation shall refuse to grant or refuse to accept type approvals to this Regulation as amended by the 01 series of amendments.
- 11.2. Even after the date of entry into force of the 01 series of amendments, Contracting Parties applying this Regulation may continue granting type approvals and shall not refuse to grant extensions of type approvals, to this Regulation in its original form.
- 11.3. Until 1 September 2016, no Contracting Party applying this Regulation shall refuse national or regional type approval of a vehicle type approved to this Regulation in its original form.
- 11.4. As from 1 September 2016, Contracting Parties applying this Regulation shall not be obliged to accept, for the purpose of national or regional type approval, vehicles having a vehicle width of 1.50 m or less, which are not type approved to this Regulation as amended by the 01 series of amendments.
- 11.5. Even after 1 September 2016, Contracting Parties applying this Regulation shall continue to accept approvals of vehicle types to this Regulation in its original form, which are not affected by the 01 series of amendments.

## Annex 1

### Communication

(maximum format: A4 (210 x 297 mm))

issued by: Name of administration:

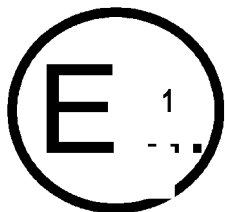

.....  
.....  
.....

Concerning: <sup>2</sup> Approval granted  
Approval extended  
Approval refused  
Approval withdrawn  
Production definitively discontinued

of a vehicle type with regard to its pole side impact performance pursuant to Regulation No. 135

Approval No. .... Extension No. ....

1. Vehicle trademark: .....
2. Vehicle type and trade names: .....
3. Name and address of manufacturer: .....
4. If applicable, name and address of manufacturer's representative: .....
5. Brief description of vehicle: .....
6. Date of submission of vehicle for approval: .....
7. WorldSID 50<sup>th</sup> male build level/specifications: .....
8. Technical Service performing the approval tests: .....
9. Date of test report issued by that Service: .....
10. Number of test report issued by that Service: .....
11. Approval granted/refused/extended/withdrawn: <sup>2</sup> .....
12. Position of approval mark on the vehicle: .....

---

<sup>1</sup> Distinguishing number of the country which has granted/extended/refused/withdrawn approval (see approval provisions in the Regulation).

<sup>2</sup> Delete what does not apply.

- 13. Place: .....
- 14. Date: .....
- 15. Signature: .....
- 16. Any remarks: .....
- 17. The list of documents deposited with the Approval Authority which has granted approval is annexed to this communication and may be obtained on request.

## Annex 2

### Arrangement of the approval mark

Model A  
 (See paragraph 4.5. of this Regulation)

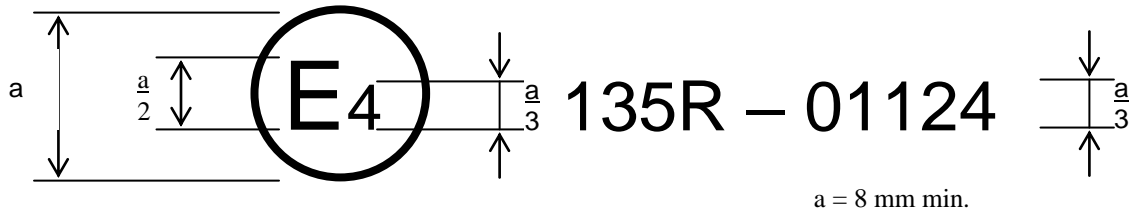

The above approval mark affixed to a vehicle shows that the vehicle type concerned has, with regard to its pole side impact performance, been approved in the Netherlands (E 4) pursuant to Regulation No. 135 under approval number 00124. The approval number indicates that the approval was granted in accordance with the requirements of Regulation No. 135 as amended by the 01 series of amendments.

Model B  
 (See paragraph 4.6. of this Regulation)

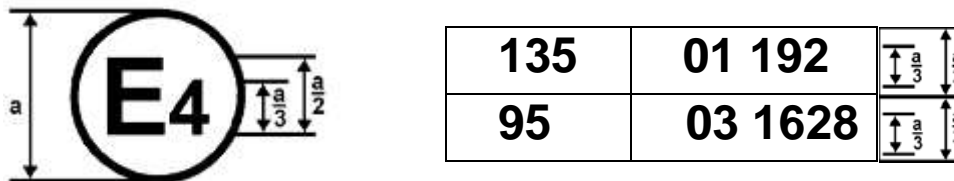

The above approval mark affixed to a vehicle shows that the vehicle type concerned has been approved in the Netherlands (E 4) pursuant to Regulations Nos. 135 and 95.<sup>1</sup> The first two digits of the approval numbers indicate that, at the dates when the respective approvals were granted, Regulation No. 135 incorporated the 01 series of amendments and Regulation No. 95 incorporated the 03 series of amendments.

<sup>1</sup> The latter number is given only as an example.



## Annex 3

### Dynamic pole side impact test procedure

1. Purpose  
Determination of compliance with the requirements of paragraph 5. of this Regulation.
2. Definitions  
For the purposes of this annex:
  - 2.1. "*Fuel ballast*" means water; or Stoddard Solvent; or any other homogeneous liquid with a specific gravity of 1.0 +0/-0.25 and a dynamic viscosity of  $0.9 \pm 0.05$  mPa·s at 25 °C.
  - 2.2. "*Impact reference line*" is the line formed on the impact side of the test vehicle by the intersection of the exterior surface of the vehicle and a vertical plane passing through the centre of gravity of the head of the dummy positioned in accordance with Annex 4, in the front-row outboard designated seating position on the impact side of the vehicle. The vertical plane forms an angle of 75° with the vehicle longitudinal centreline. The angle is measured as indicated in Annex 7, Figure 7-1 (or Figure 7-2) for left (or right) side impact.
  - 2.3. "*Impact velocity vector*" means the geometric quantity which describes both the speed and direction of travel of the vehicle at the moment of impact with the pole. The impact velocity vector points in the direction of travel of the vehicle. The origin of the impact velocity vector is the centre of gravity of the vehicle and its magnitude (length) describes the impact speed of the vehicle.
  - 2.4. "*Laden attitude*" means the pitch and roll angle of the test vehicle when positioned on a level surface with all tyres fitted and inflated as recommended by the vehicle manufacturer and loaded to the laden mass. The test vehicle is loaded by centrally positioning 136 kg or the rated cargo and luggage mass (whichever is less) in the cargo/luggage carrying area over the longitudinal centreline of the vehicle. The mass of the necessary anthropomorphic test device is placed on the front-row outboard designated seating position on the impact side of the vehicle. The front-row seat on the impact side of the vehicle is positioned in accordance with Annex 4.
  - 2.5. "*Laden mass*" means unladen vehicle mass, plus 136 kg or the rated cargo and luggage mass (whichever is less), plus the mass of the necessary anthropomorphic test device.
  - 2.6. "*Pitch angle*" is the angle of a fixed linear reference connecting two reference points on the front left or right door sill (as applicable), relative to a level surface or horizontal reference plane. An example of a suitable fixed linear reference for left side door sill pitch angle measurement is illustrated in Figure 9-1 of Annex 9.
  - 2.7. "*Pole*" means a fixed rigid vertically oriented metal structure with a continuous outer cross section diameter of  $254 \text{ mm} \pm 6 \text{ mm}$ , beginning no more than 102 mm above the lowest point of the tyres on the impact side of the vehicle in the laden attitude, and extending at least above the highest point of the roof of the test vehicle.

- 2.8. "Roll angle" is the angle of a fixed linear reference connecting two reference points either side of the vehicle longitudinal centre plane on the front or rear (as applicable) of the vehicle body, relative to a level surface or horizontal reference plane. An example of a suitable fixed linear reference for rear roll angle measurement is illustrated in Figure 9-2 of Annex 9.
- 2.9. "Specific gravity" means the density of a reference liquid expressed as a ratio of the density of water (i.e.  $\rho_{\text{liquid}}/\rho_{\text{water}}$ ) at 25 °C reference temperature and 101.325 kPa reference pressure.
- 2.10. "Stoddard solvent" means a homogeneous, transparent, petroleum distillate mixture of refined C<sub>7</sub>-C<sub>12</sub> hydrocarbons; with a flash point of at least 38 °C, a specific gravity of  $0.78 \pm 0.03$  and a dynamic viscosity of  $0.9 \pm 0.05$  mPa·s at 25 °C.
- 2.11. "Test attitude" means the pitch and roll angle of the test vehicle to be impacted with the pole.
- 2.12. "Unladen attitude" means the pitch and roll angle of the unladen vehicle when positioned on a level surface with all tyres fitted and inflated as recommended by the vehicle manufacturer.
- 2.13. "Useable fuel tank capacity" means the fuel tank capacity specified by the vehicle manufacturer.
- 2.14. "Vehicle master control switch" means the device by which the vehicle's onboard electronics system is brought from being switched off, as is the case when the vehicle is parked without the driver present, to the normal operating mode.
- 2.15. "Vehicle fuel" means the optimum fuel recommended by the vehicle manufacturer for the applicable fuel system.
- 3. State of the test vehicle
  - 3.1. The test vehicle shall be representative of the series production, shall include all the equipment normally fitted and shall be in normal running order.
  - 3.2. Notwithstanding paragraph 3.1. of this annex above, some components may be omitted or replaced by equivalent masses where the Approval Authority in consultation with the manufacturer and the Technical Service, considers that any such omission or substitution will have no effect on the results of the test.
- 4. Test equipment
  - 4.1. Test vehicle preparation area
    - 4.1.1. An enclosed temperature controlled area suitable for ensuring stabilization of the test dummy temperature prior to testing.
  - 4.2. Pole
    - 4.2.1. A pole satisfying the definition of paragraph 2.7. of this annex, and offset from any mounting surface, such as a barrier or other structure, so that the test vehicle will not contact such a mount or support at any time within 100 ms of the initiation of vehicle-to-pole contact.
  - 4.3. Anthropomorphic Test Devices
    - 4.3.1. A WorldSID 50<sup>th</sup> percentile adult male dummy in accordance with Addendum 2 of Mutual Resolution No.1 and fitted with (as a minimum) all instrumentation required to obtain the data channels necessary to determine the dummy performance criteria listed in paragraph 5.3. of this Regulation.

5. Vehicle preparation
  - 5.1. Fuel systems designed for fuel with a boiling point above 0 °C shall be prepared in accordance with paragraphs 5.1.1. and 5.1.2.
    - 5.1.1. The fuel tank shall be filled with fuel ballast<sup>1</sup> of mass:
      - 5.1.1.1. Greater than or equal to the mass of the vehicle fuel required to fill 90 per cent of the useable fuel tank capacity; and
      - 5.1.1.2. Less than or equal to the mass of the vehicle fuel required to fill 100 per cent of the useable fuel tank capacity.
    - 5.1.2. Fuel ballast shall be used to fill the entire fuel system from the fuel tank through to the engine induction system.
  - 5.2. The compressed hydrogen storage system(s) and enclosed spaces of compressed hydrogen-fuelled vehicles shall be prepared in accordance with paragraph 3. of Annex 6.
  - 5.3. The other (non-fuel) liquid containing vehicle systems may be empty, in which case, the mass of the liquids (e.g. brake fluid, coolant, transmission fluid) shall be replaced by the equivalent ballast mass.
  - 5.4. The vehicle test mass, including the mass of the necessary anthropomorphic test device and any ballast mass, shall be within +0/-10 kg of the laden mass defined in paragraph 2.5. of this annex.
  - 5.5. The pitch angles measured on the left and right side of the vehicle in the test attitude shall be between the corresponding (left or right as applicable) unladen attitude pitch angle and laden attitude pitch angle, inclusive.
  - 5.6. Each linear reference used to measure the unladen, laden and test attitude pitch angles on the left or right side of the vehicle in paragraph 5.5. above shall connect the same fixed reference points on the left or right (as applicable) side door sill.
  - 5.7. The roll angles measured at the front and rear of the vehicle in the test attitude shall be between the corresponding (front or rear as applicable) unladen attitude roll angle and laden attitude roll angle, inclusive.
  - 5.8. Each linear reference used to measure the unladen, laden and test attitude roll angles at the front or rear of the vehicle in paragraph 5.7. above shall connect the same fixed reference points on the front or rear (as applicable) vehicle body.
6. Vehicle passenger compartment adjustments
  - 6.1. Adjustable front-row seats
    - 6.1.1. Any seat adjustment, including any seat cushion, seatback, armrest, lumbar support, and head restraint; of a front-row outboard seating position on the impact side of the vehicle; shall be placed in the position of adjustment specified in Annex 4.

---

<sup>1</sup> For safety reasons, flammable liquids with a flash point below 38°C are not recommended for use as fuel ballast.

- 6.2. Adjustable front-row safety-belt anchorages
  - 6.2.1. Any adjustable safety-belt anchorage(s) provided for a front-row outboard seating position on the impact side of the vehicle, shall be placed in the position of adjustment specified in Annex 4.
- 6.3. Adjustable steering wheels
  - 6.3.1. Any adjustable steering wheel shall be placed in the position of adjustment specified in Annex 4.
- 6.4. Convertible tops
  - 6.4.1. Convertibles and open-body type vehicles shall have the top, if any, in place in the closed passenger compartment configuration.
- 6.5. Doors
  - 6.5.1. Doors, including any back door (e.g. a hatchback or tailgate), shall be fully closed and fully latched, but not locked.
- 6.6. Parking brake
  - 6.6.1. The parking brake shall be engaged.
- 6.7. Electrical system
  - 6.7.1. The vehicle master control switch shall be in the "on" position.
- 6.8. Pedals
  - 6.8.1. Any adjustable pedals shall be placed as specified in Annex 4.
- 6.9. Windows, vents and sunroofs
  - 6.9.1. Moveable vehicle windows and vents located on the impact side of the vehicle shall be placed in the fully closed position.
  - 6.9.2. Any sunroof(s) shall be placed in the fully closed position.
- 7. Dummy preparation and positioning
  - 7.1. A WorldSID 50<sup>th</sup> percentile adult male dummy in accordance with paragraph 4.3.1. of this annex shall be installed in accordance with Annex 4, in the front-row outboard seat located on the impact side of the vehicle.
  - 7.2. The test dummy shall be configured and instrumented to be struck on the side closest to the side of the vehicle impacting the pole.
  - 7.3. The stabilised temperature of the test dummy at the time of the test shall be between 20.6 °C and 22.2 °C.
  - 7.4. A stabilised dummy temperature shall be obtained by soaking the dummy at controlled test laboratory environment temperatures within the range specified in paragraph 7.3. above prior to the test.
  - 7.5. The stabilised temperature of the test dummy shall be recorded by an internal dummy chest cavity temperature sensor.
- 8. Vehicle-to-pole side impact test
  - 8.1. A test vehicle prepared in accordance with paragraph 5., paragraph 6. and paragraph 7. of this annex, shall be impacted into a stationary pole.
  - 8.2. The test vehicle shall be propelled so that, when the vehicle-to-pole contact occurs, the direction of vehicle motion forms an angle of  $75^{\circ} \pm 3^{\circ}$  with the vehicle longitudinal centreline.

- 8.3. The angle in paragraph 8.2. above shall be measured between the vehicle longitudinal centreline and a vertical plane parallel to the vehicle impact velocity vector, as indicated in Annex 8, Figure 8-1 (or Figure 8-2) for left (or right) side impact.
- 8.4. The impact reference line shall be aligned with the centreline of the rigid pole surface, as viewed in the direction of vehicle motion, so that, when the vehicle-to-pole contact occurs, the centreline of the pole surface contacts the vehicle area bounded by two vertical planes parallel to and 25 mm forward and aft of the impact reference line.
- 8.5. During the acceleration phase of the test prior to first contact between the vehicle and the pole, the acceleration of the test vehicle shall not exceed  $1.5 \text{ m/s}^2$ .
- 8.6. The test vehicle speed at the moment of first vehicle-to-pole contact shall be  $32 \pm 1 \text{ km/h}$ .

## Annex 4

### Seat adjustment and installation requirements for the WorldSID 50<sup>th</sup> percentile adult male dummy

1. Purpose  
Repeatable and reproducible front-row seat installation of the WorldSID 50<sup>th</sup> percentile adult male dummy in a vehicle seat position and automotive seating posture representative of a typical mid-size adult male.
2. Definitions  
For the purposes of this annex:
  - 2.1. "*Actual torso angle*" means the angle measured between a vertical line through the manikin H-point and the torso line using the back angle quadrant on the 3-D H machine.
  - 2.2. "*Centre plane of occupant (C/LO)*" means the median plane of the 3-D H machine positioned in each designated seating position. It is represented by the lateral (Y-axis) coordinate of the H-point in the vehicle reference coordinate system. For individual seats, the vertical median plane of the seat coincides with the centre plane of the occupant. For driver bench seating positions, the centre plane of the occupant coincides with the geometric centre of the steering wheel hub. For other seats, the centre plane of the occupant is specified by the manufacturer.
  - 2.3. "*Design rib angle*" means the nominal (theoretical) angle of the WorldSID 50<sup>th</sup> percentile adult male middle thorax, lower thorax and abdominal ribs relative to a level surface or horizontal reference plane, as defined by the manufacturer for the final adjustment position of the seat in which the dummy is to be installed. The design rib angle corresponds theoretically to the design torso angle minus 25°.
  - 2.4. "*Design torso angle*" means the angle measured between a vertical line through the manikin H-point and the torso line in a position which corresponds to the nominal design position of the seat back for a 50<sup>th</sup> percentile adult male occupant established by the vehicle manufacturer.
  - 2.5. "*Dummy H-point*" means the coordinate point midway between the H-point locator assembly measurement points on each side of the test dummy pelvis. <sup>1</sup>
  - 2.6. "*Dummy rib angle*" means the angle of the test dummy middle thorax, lower thorax and abdominal ribs relative to a level surface or horizontal reference plane as established by the thorax tilt sensor angle reading about the sensor y-axis. The dummy rib angle corresponds theoretically to the actual torso angle minus 25°.
  - 2.7. "*Fiducial marks*" are physical points (holes, surfaces, marks or indentations) on the vehicle body.
  - 2.8. "*Leg (for dummy installation purposes)*" refers to the lower part of the entire leg assembly between, and including, the foot and the knee assembly.

---

<sup>1</sup> Details of the H-point locator assembly (H-point tool) including dimensions are specified in Addendum 2 of Mutual Resolution No.1.

- 2.9. "*Manikin H-point*" means the pivot centre of the torso and thigh of the 3-D H machine when installed in a vehicle seat in accordance with paragraph 6. of this annex. The manikin H-point is located at the centre of the centreline of the device, between the H-point sight buttons on either side of the 3-D H machine. Once determined in accordance with the procedure described in paragraph 6. of this annex, the manikin H-point is considered fixed in relation to the seat cushion support structure and is considered to move with it when the seat is adjusted.
- 2.10. "*Mid-sagittal plane*" means the median plane of the test dummy; located midway between and parallel to the dummy spine box side plates.
- 2.11. "*Muslin cotton*" means a plain cotton fabric having 18.9 threads per cm<sup>2</sup> and weighing 0.228 kg/m<sup>2</sup> or knitted or non-woven fabric having comparable characteristics.
- 2.12. "*Seat cushion reference line*" means a planar line along the side surface of the seat cushion base and passing through the SCRCP defined in paragraph 2.14. of this annex. The seat cushion reference line may be marked on the side of a seat cushion support structure and/or its position defined using an additional reference point. The projection of the seat cushion reference line to a vertical longitudinal plane is linear (i.e. straight).
- 2.13. "*Seat cushion reference line angle*" means the angle of the seat cushion reference line projection in a vertical longitudinal plane, relative to a level surface or horizontal reference plane.
- 2.14. "*Seat cushion reference point*" (SCRCP) means the measurement point identified, placed or marked on the outboard side of a seat cushion support structure to record the longitudinal (fore/aft) and vertical travel of an adjustable seat cushion.
- 2.15. "*Shoulder median plane*" means a plane dividing the left or right (as applicable) shoulder clevis into symmetrical anterior/posterior sections. The shoulder median plane is perpendicular to the centreline of the shoulder pivot shaft and parallel to the shoulder load cell y-axis (or an equivalently oriented axis of a shoulder load cell structural replacement).
- 2.16. "*Thigh (for dummy installation purposes)*" refers to the distal upper leg flesh section of the test dummy between, but not including, the knee assembly and the pelvis flesh.
- 2.17. "*Three-dimensional H-point machine*" (3-D H machine) means the device used for the determination of manikin H-points and actual torso angles. This device is defined in Annex 5.
- 2.18. "*Torso line*" means the centreline of the probe of the 3-D H machine with the probe in the fully rearward position.
- 2.19. "*Vehicle measuring attitude*" means the position of the vehicle body as defined by the coordinates of at least three fiducial marks; sufficiently separated in the longitudinal (X), transverse (Y) and vertical (Z) axes of the vehicle reference coordinate system, to enable accurate alignment with the measurement axes of a coordinate measurement machine.
- 2.20. "*Vehicle reference coordinate system*" means an orthogonal coordinate system consisting of three axes; a longitudinal axis (X), a transverse axis (Y), and a vertical axis (Z). X and Y are in the same horizontal plane and Z passes through the intersection of X and Y. The X-axis is parallel to the longitudinal centre plane of the vehicle.

- 2.21. "Vertical longitudinal plane" means a vertical plane, parallel to the vehicle longitudinal centreline.
- 2.22. "Vertical longitudinal zero plane" means a vertical longitudinal plane passing through the origin of the vehicle reference coordinate system.
- 2.23. "Vertical plane" means a vertical plane, not necessarily perpendicular or parallel to the vehicle longitudinal centreline.
- 2.24. "Vertical transverse plane" means a vertical plane, perpendicular to the vehicle longitudinal centreline.
- 2.25. "WS50M H-point" means the coordinate point located 20 mm longitudinally forward in the vehicle reference coordinate system of the manikin H-point determined in accordance with paragraph 6. of this annex.
- 3. Establishment of the vehicle measuring attitude
  - 3.1. A vehicle measuring attitude shall be established by positioning the test vehicle on a level surface and adjusting the attitude of the test vehicle body such that:
    - 3.1.1. the vehicle longitudinal centre plane is parallel to the vertical longitudinal zero plane; and
    - 3.1.2. the front left and right door sill pitch angles satisfy the vehicle test attitude requirements of paragraph 5.5. of Annex 3.
- 4. Seat comfort and head restraint adjustments
  - 4.1. Where applicable, the test seat adjustments specified in paragraphs 4.1.1. to 4.1.3. shall be performed on the seat in which the dummy is to be installed.
    - 4.1.1. Adjustable lumbar supports
      - 4.1.1.1. Any adjustable lumbar support(s) shall be adjusted so that the lumbar support is in the lowest, retracted or most deflated adjustment position.
      - 4.1.2. Other adjustable seat support systems
        - 4.1.2.1. Any other adjustable seat supports, such as seat cushions adjustable in length and leg support systems, shall be adjusted to the rearmost or most retracted adjustment position.
    - 4.1.3. Head restraints
      - 4.1.3.1. The head restraint shall be adjusted to the vehicle manufacturer's nominal design position for a 50<sup>th</sup> percentile adult male occupant or the uppermost position if no design position is available.
- 5. Passenger compartment adjustments
  - 5.1. Where applicable, the adjustment specified in paragraph 5.1.1. of this annex; and in the case where the dummy is to be installed on the driver's side, the adjustments specified in paragraphs 5.1.2. and 5.1.3. of this annex; shall be performed on the vehicle.
    - 5.1.1. Adjustable safety-belt anchorages
      - 5.1.1.1. Any adjustable safety-belt anchorage(s) provided for the seating position at which the dummy is to be installed, shall be placed at the vehicle manufacturer's nominal design position for a 50<sup>th</sup> percentile adult male occupant, or in the fully up position if no design position is available.



- 5.1.2. Adjustable steering wheels
- 5.1.2.1. An adjustable steering wheel shall be adjusted to the geometric highest driving position, considering all telescopic and tilt adjustment positions available.<sup>2</sup>
- 5.1.3. Adjustable pedals
- 5.1.3.1. Any adjustable pedals shall be placed in the full forward position (i.e. towards the front of the vehicle).
- 6. Procedure for establishing the test position of an adjustable seat cushion
- 6.1. A Seat Cushion Reference Point (SCRCP) shall be used to measure and record adjustments made to seat cushions equipped with controls for longitudinal (fore/aft) and/or vertical seat cushion adjustment.
- 6.2. The SCRCP should be located on a part of the seat cushion side structure or support frame which is fixed in location with respect to the seat cushion.
- 6.3. A seat cushion reference line shall be used to measure and record angular adjustments made to pitch adjustable seat cushions.
- 6.4. For pitch adjustable seat cushions, the SCRCP location should be set as close as possible to the axis of rotation (e.g. towards the rear) of the seat cushion support structure.
- 6.5. The adjustment position of the seat cushion base on which the dummy is to be installed shall be determined by sequential completion (where applicable to the seat design) of the steps outlined in paragraphs 6.6. to 6.13. of this annex below; with the test vehicle at the vehicle measuring attitude established in accordance with paragraph 3. of this annex above.
- 6.6. Use the seat control that primarily moves the seat vertically to adjust the SCRCP to the uppermost vertical location.
- 6.7. Use the seat control that primarily moves the seat fore/aft to adjust the SCRCP to the rearmost location.
- 6.8. Determine and record (by measuring the seat cushion reference line angle), the full angular adjustment range of the seat cushion pitch and using only the control(s) that primarily adjust(s) the cushion pitch, set the cushion pitch as close as possible to the mid-angle.
- 6.9. Use the seat control that primarily moves the seat vertically to adjust the SCRCP to the lowest vertical location. Verify that the seat cushion is still at the rearmost seat track location. Record the longitudinal (X-axis) position of the SCRCP in the vehicle reference coordinate system.
- 6.10. Use the seat control that primarily moves the seat fore/aft to adjust the SCRCP to the forward most location. Record the longitudinal (X-axis) position of the SCRCP in the vehicle reference coordinate system.
- 6.11. Determine the vehicle X-axis position of a vertical transverse plane 20 mm rearward of a point midway between the longitudinal (X-axis) positions recorded in accordance with paragraphs 6.9. and 6.10. above (i.e. 20 mm rearward of the mid-track position).

---

<sup>2</sup> The steering wheel is not expected to influence the loading of the dummy – the highest position is specified in order to provide maximum clearance of the dummy legs and thorax.

- 6.12. Use the seat control that primarily moves the seat fore/aft to adjust the SCRP to the longitudinal (X-axis) position determined in accordance with paragraph 6.11. (-0/+2 mm), or, if this is not possible, the first available fore/aft adjustment position rearward of the position determined in accordance with paragraph 6.11.
- 6.13. Record the longitudinal (X-axis) position of the SCRP in the vehicle reference coordinate system and measure the seat cushion reference line angle for future reference. Except as provided in paragraph 8.4.6. of this annex; this adjustment position shall be used as the final seat cushion adjustment position for the installation of the dummy. <sup>3</sup>
- 7. Procedure for manikin H-point and actual torso angle determination
  - 7.1. The test vehicle shall be preconditioned at a temperature of 20 °C ± 10 °C to ensure that the seat material reaches stabilised room temperature for the installation of the 3-D H machine.
  - 7.2. Adjustable lumbar supports and other adjustable seat supports shall be set to the adjustment positions specified in paragraph 4.1.1. and 4.1.2. of this annex.
  - 7.3. The manikin H-point coordinates and final actual torso angle shall be determined for the seat in which the dummy is to be installed, by sequential completion of the steps outlined in paragraphs 7.4. to 7.24. of this annex below; with the test vehicle at the vehicle measuring attitude established in accordance with paragraph 3. of this annex above.
  - 7.4. Cover the area of the seating position to be contacted by the 3-D H machine with a muslin cotton sheet of sufficient size and place the seat and back assembly of the 3-D H machine in the seat.
  - 7.5. Set the seat cushion position to the adjustment position recorded in accordance with paragraph 6.13. of this annex.
  - 7.6. Using only the control(s) which primarily adjusts the angle of the seat back, independently of the seat cushion pitch; adjust the seat back position according to one of the following methods:
    - 7.6.1. Place adjustable seat backs in the manufacturer's nominal design driving or riding position for a 50<sup>th</sup> percentile adult male occupant, in the manner specified by the manufacturer.
    - 7.6.2. Where a design seat back position is not specified by the manufacturer:
      - 7.6.2.1. Set the seat back to the first detent position rearward of 25° from the vertical.
      - 7.6.2.2. If there is no detent position rearward of 25° from the vertical, set the seat back angle to the most reclined adjustment position.
  - 7.7. Adjust the seat and back assembly of the 3-D H machine so that the centre plane of the occupant (C/LO) coincides with the centre plane of the 3-D H machine.
  - 7.8. Set the lower leg segments to the 50<sup>th</sup> percentile length (417 mm) and the thigh bar segment to the 10<sup>th</sup> percentile length (408 mm).

---

<sup>3</sup> For some seats, the adjustments specified in paragraphs 6.9. to 6.12. may automatically alter the seat cushion pitch from the mid-angle established in accordance with paragraph 6.8. This is acceptable.

- 7.9. Attach the foot and lower leg assemblies to the seat pan assembly, either individually or by using the T-bar and lower leg assembly. The line through the H-point sight buttons should be parallel to the ground and perpendicular to the C/LO of the seat.
- 7.10. Adjust the feet and leg positions of the 3-D H machine as follows:
  - 7.10.1. Both feet and leg assemblies are moved forward in such a way that the feet take up natural positions on the floor, between the operating pedals if necessary. Where possible, the left foot is located approximately the same distance to the left of the centre plane of the 3-D H machine as the right foot is to the right. The spirit level verifying the transverse orientation of the 3-D H machine is brought to the horizontal by readjustment of the seat pan if necessary, or by adjusting the leg and foot assemblies towards the rear. The line passing through the H-point sight buttons is maintained perpendicular to the C/LO of the seat.
  - 7.10.2. If the left leg cannot be kept parallel to the right leg and the left foot cannot be supported by the structure, move the left foot until it is supported. The alignment of the sight buttons is maintained.
- 7.11. Apply the lower leg and thigh weights and level the 3-D H machine.
- 7.12. Tilt the back pan forward against the forward stop and draw the 3-D H machine away from the seat back using the T-bar. Reposition the 3-D H machine on the seat by one of the following methods:
  - 7.12.1. If the 3-D H machine tends to slide rearward, use the following procedure. Allow the 3-D H machine to slide rearward until a forward horizontal restraining load on the T-bar is no longer required (i.e. until the seat pan contacts the seat back). If necessary, reposition the lower leg.
  - 7.12.2. If the 3-D H machine does not tend to slide rearward, use the following procedure. Slide the 3-D H machine rearwards by applying a horizontal rearward load to the T-bar until the seat pan contacts the seat back (see Figure 5-2 of Annex 5).
- 7.13. Apply a  $100\text{ N} \pm 10\text{ N}$  load to the back and pan assembly of the 3-D H machine at the intersection of the hip angle quadrant and the T-bar housing. The direction of load application is maintained along a line passing by the above intersection to a point just above the thigh bar housing (see Figure 5-2 of Annex 5). Then carefully return the back pan to the seat back. Care must be exercised throughout the remainder of the procedure to prevent the 3-D H machine from sliding forward.
- 7.14. Install the right and left buttock weights and then, alternately, the eight torso weights. Maintain the 3-D H machine level.
- 7.15. Tilt the back pan forward to release the tension on the seat back. Rock the 3-D H machine from side to side through 10 degrees arc (5 degrees to each side of the vertical centre plane) for three complete cycles to release any accumulated friction between the 3-D H machine and the seat.
  - 7.15.1. During the rocking action, the T-bar of the 3-D H machine may tend to diverge from the specified horizontal and vertical alignment. The T-bar must therefore be restrained by applying an appropriate lateral load during the rocking motions. Care is exercised in holding the T-bar and rocking the 3-D H machine to ensure that no inadvertent exterior loads are applied in a vertical or fore and aft directions.

- 7.15.2. The feet of the 3-D H machine are not to be restrained or held during this step. If the feet change position, they should be allowed to remain in that attitude for the moment.
- 7.16. Carefully return the back pan to the seat back and check the two spirit levels for zero position. If any movement of the feet has occurred during the rocking operation of the 3-D H machine, they must be repositioned as follows:
  - 7.16.1. Alternately, lift each foot off the floor the minimum necessary amount until no additional foot movement is obtained. During this lifting, the feet are to be free to rotate; and no forward or lateral loads are to be applied. When each foot is placed back in the down position, the heel is to be in contact with the structure designed for this.
- 7.17. Check the lateral spirit level for zero position; if necessary, apply a lateral load to the top of the back pan sufficient to level the 3-D H machine's seat pan on the seat.
- 7.18. Holding the T-bar to prevent the 3-D H machine from sliding forward on the seat cushion, proceed as follows:
  - 7.18.1. Return the back pan to the seat back; and
  - 7.18.2. Alternately apply and release a horizontal rearward load, not to exceed 25 N, to the back angle bar at a height approximately at the centre of the torso weights until the hip angle quadrant indicates that a stable position has been reached after load release. Care is exercised to ensure that no exterior downward or lateral loads are applied to the 3-D H machine. If another level adjustment of the 3-D H machine is necessary, rotate the back pan forward, re-level, and repeat all procedures from paragraph 6.15. of this annex onwards.
- 7.19. Use the 3-D H machine back angle quadrant, with the head room probe in its fully rearward position, to measure the actual torso angle.
- 7.20. If necessary, use only the control(s) which primarily adjusts the angle of the seat back independently of the seat cushion pitch; to adjust the actual torso angle to the design torso angle  $\pm 1^\circ$  specified by the manufacturer.
- 7.21. Where a design torso angle is not specified by the manufacturer:
  - 7.21.1. use only the control(s) which primarily adjusts the angle of the seat back independently of the seat cushion pitch; to adjust the actual torso angle to  $23^\circ \pm 1^\circ$ .
- 7.22. Where a design torso angle is not specified by the manufacturer and no seat back angular adjustment position produces an actual torso angle within the  $23^\circ \pm 1^\circ$  range:
  - 7.22.1. use only the control(s) which primarily adjusts the angle of the seat back independently of the seat cushion pitch; to adjust the actual torso angle as close to  $23^\circ$  as possible.
- 7.23. Record the final actual torso angle for future reference.
- 7.24. Measure and record the manikin H-point (X, Y, Z) coordinates in the vehicle reference coordinate system for future reference.

- 7.25. Except as provided in paragraph 8.4.6. of this annex; the coordinates recorded in accordance with paragraph 7.24. above define the manikin H-point location of the seat, when the seat is adjusted to the final seat cushion and seat back detent test positions for the installation of the dummy.
- 7.26. If a rerun of the installation of the 3-D H machine is desired, the seat assembly should remain unloaded for a minimum period of 30 minutes prior to the rerun. The 3-D H machine should not be left loaded on the seat assembly longer than the time required to perform the test.
8. WorldSID 50<sup>th</sup> percentile adult male installation requirements
- 8.1. Adjustable lumbar supports, other adjustable seat supports and adjustable head restraints shall be set to the adjustment positions specified in paragraph 4. of this annex.
- 8.2. Passenger compartment adjustments shall be set to the adjustment positions specified in paragraph 5. of this annex.
- 8.3. The test dummy shall then be installed by completion of the steps outlined in paragraph 8.4. below; with the test vehicle at the vehicle measuring attitude established in accordance with paragraph 3. of this annex.
- 8.4. Dummy installation procedure
- 8.4.1. Place the test dummy in the applicable seat such that the mid-sagittal plane is coincident with the C/LO and the upper torso is resting against the seat back.<sup>4</sup>
- 8.4.2. Apply a for/aft and lateral rocking motion to settle the pelvis rearward in the seat.<sup>5</sup>
- 8.4.3. Where the abdominal rib coupler and/or the outer band of each (i.e. left/right) lower abdominal rib assembly contacts the pelvis flesh, ensure the contacting surfaces of the abdominal rib coupler and the outer band of each lower abdominal rib are positioned in-behind the inner abdominal wall of the pelvis flesh, not on top of the pelvis flesh.
- 8.4.4. Move the seat cushion and seat back together with the test dummy to the final adjustment position used to determine the manikin H-point and actual torso angle in paragraph 7. of this annex.
- 8.4.5. Verify that the dummy H-point is reasonably close ( $\pm 10$  mm) to the WS50M H-point defined in paragraph 2.25. of this annex. If not, repeat the procedures outlined in paragraphs 8.4.2. to 8.4.3. of this annex. If it is still not possible to verify the dummy H-point is reasonably close ( $\pm 10$  mm) to the WS50M H-point, record the offset and proceed to the next step.
- 8.4.6. If it is not possible to reach the seat test position due to knee contact, shift the targeted test seat position rearwards in stepwise increments to the closest position where the knee clearance is at least 5 mm. Record the adjustment of the SCRIP position and modify the manikin H-point and WS50M H-point coordinates accordingly.

---

<sup>4</sup> Seat centreline markings may be used to identify the C/LO and to facilitate placement of the dummy.

<sup>5</sup> To ensure that a repeatable and stable pelvis position will be achieved, it is recommended following the completion of this step, to verify that the pelvis is in contact with the seat cushion over the whole pelvis length.

- 8.4.7. For a driver seating position:
  - 8.4.7.1. Extend the right leg without displacing the thigh from the seat cushion and allow the sole of the foot to settle on the accelerator pedal. The heel of the shoe should be in contact with the floor-pan.
  - 8.4.7.2. Extend the left leg without displacing the thigh from the seat cushion and allow the sole of the foot to settle on the footrest. The heel of the shoe should be in contact with the floor-pan. In case of tibia contact, slide the foot rearward (towards the seat) until a 5 mm clearance is obtained.
- 8.4.8. For a passenger seating position:
  - 8.4.8.1. Extend each leg without displacing the thigh from the seat cushion.
  - 8.4.8.2. Allow the sole of the right foot to settle on the floor-pan in-line (i.e. in the same vertical plane) with the thigh. The heel of the shoe should be in contact with the floor-pan. If the contour of the floor-pan does not permit the foot to rest on a planar surface, move the foot in 5 mm increments until the foot rests on a planar surface.
  - 8.4.8.3. Allow the sole of the left foot to settle on the floor-pan in-line (i.e. in the same vertical plane) with the thigh and in the same for/aft location (alignment) as the right foot. The heel of the shoe should be in contact with the floor-pan. If the contour of the floor-pan does not permit the foot to rest on a planar surface, move the foot in 5 mm increments until the foot rests on a planar surface.
- 8.4.9. Position the dummy H-point to match the WS50M H-point coordinates (defined by paragraph 2.25. of this annex) within  $\pm 5$  mm. Priority should be given to the X-axis coordinate.
- 8.4.10. Adjust the dummy rib angle as follows:
  - 8.4.10.1. Adjust the dummy until the thorax tilt sensor angle reading (about the sensor y-axis) is within  $\pm 1^\circ$  of the design rib angle specified by the manufacturer.
  - 8.4.10.2. Where a design rib angle is not specified by the manufacturer and the final actual torso angle determined in accordance with paragraph 7. of this annex is  $23^\circ \pm 1^\circ$ ; adjust the dummy until the thorax tilt sensor reads  $-2^\circ$  (i.e.  $2^\circ$  downwards)  $\pm 1^\circ$  (about the sensor y-axis).
  - 8.4.10.3. Where a design rib angle is not specified by the manufacturer and the final actual torso angle recorded in accordance with paragraph 7. of this annex is not  $23^\circ \pm 1^\circ$ ; no further adjustment of the dummy rib angle is required.
- 8.4.11. Adjust the test dummy neck bracket to level the head at the closest position to  $0^\circ$  (as measured about the head core tilt sensor y-axis).
- 8.4.12. Proceed to the final foot and leg positioning by repeating the steps outlined in paragraph 8.4.7. of this annex for a driver seating position or the steps outlined in paragraph 8.4.8. of this annex for a passenger seating position.
- 8.4.13. Verify that the test dummy H-point and dummy rib angle are still in accordance with paragraphs 8.4.9. and 8.4.10. of this annex respectively. If not, repeat the steps outlined from paragraph 8.4.9. of this annex onwards.
- 8.4.14. Measure and record the final test dummy H-point position in the vehicle reference coordinate system and record the final dummy rib angle and head core tilt sensor angles.

- 8.4.15. Place both arms at the 48° detent position. In this position, each half arm bone plane of symmetry forms an angle of  $48^\circ \pm 1^\circ$  with the adjacent (i.e. left/right as applicable) shoulder median plane.
- 8.5. Dummy installation notes and recommendations
  - 8.5.1. No distance is specified for the test dummy knee spacing. However, priority should be given to ensure:
    - 8.5.1.1. At least 5 mm clearance between the knees/legs and the steering shroud and centre console;
    - 8.5.1.2. A stable foot and ankle position; and
    - 8.5.1.3. The legs are as parallel as possible to the mid-sagittal plane.
  - 8.6. Safety-belt system
    - 8.6.1. The dummy installed in accordance with paragraph 8.4. of this annex shall be restrained as follows using the safety-belt system provided for the seating position by the manufacturer:
      - 8.6.1.1. Carefully place the safety-belt across the dummy and fasten as normal.
      - 8.6.1.2. Remove slack from the lap section of the webbing until it is resting gently around the pelvis of the dummy. Only minimal force should be applied to the webbing when removing slack. The route of the lap-belt should be as natural as possible.
      - 8.6.1.3. Place one finger behind the diagonal section of the webbing at the height of the dummy sternum. Pull the webbing horizontally forward and away from the chest, and utilizing the force provided by the retractor mechanism only, allow it to freely retract in the direction of the upper anchorage. Repeat this step three times.

## Annex 5

### Description of the three-dimensional H-point machine <sup>1</sup> (3-D H machine)

1. Back and seat pans  
The back and seat pans are constructed of reinforced plastic and metal; they simulate the human torso and thigh and are mechanically hinged at the H-point. A quadrant is fastened to the probe hinged at the H-point to measure the actual torso angle. An adjustable thigh bar, attached to the seat pan, establishes the thigh centreline and serves as a baseline for the hip angle quadrant.
2. Body and leg elements  
Lower leg segments are connected to the seat pan assembly at the T-bar joining the knees, which is a lateral extension of the adjustable thigh bar. Quadrants are incorporated in the lower leg segments to measure knee angles. Shoe and foot assemblies are calibrated to measure the foot angle. Two spirit levels orient the device in space. Body element weights are placed at the corresponding centres of gravity to provide seat penetration equivalent to a 76 kg male. All joints of the 3-D H machine should be checked for free movement without encountering noticeable friction.

---

<sup>1</sup> For details of the construction of the 3-D H machine refer to SAE International (SAE), 400 Commonwealth Drive, Warrendale, Pennsylvania 15096, United States of America (SAE J826 1995 version). The machine corresponds to that described in ISO Standard 6549: 1999.



Figure 5-1  
3-D H machine elements designation

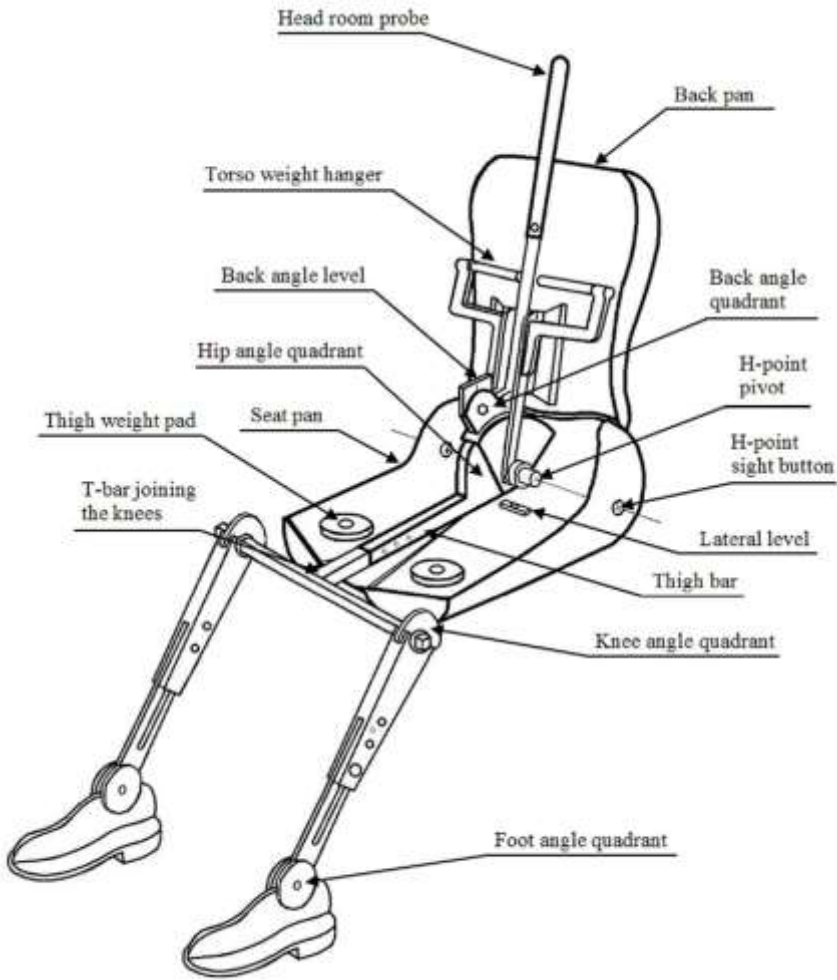
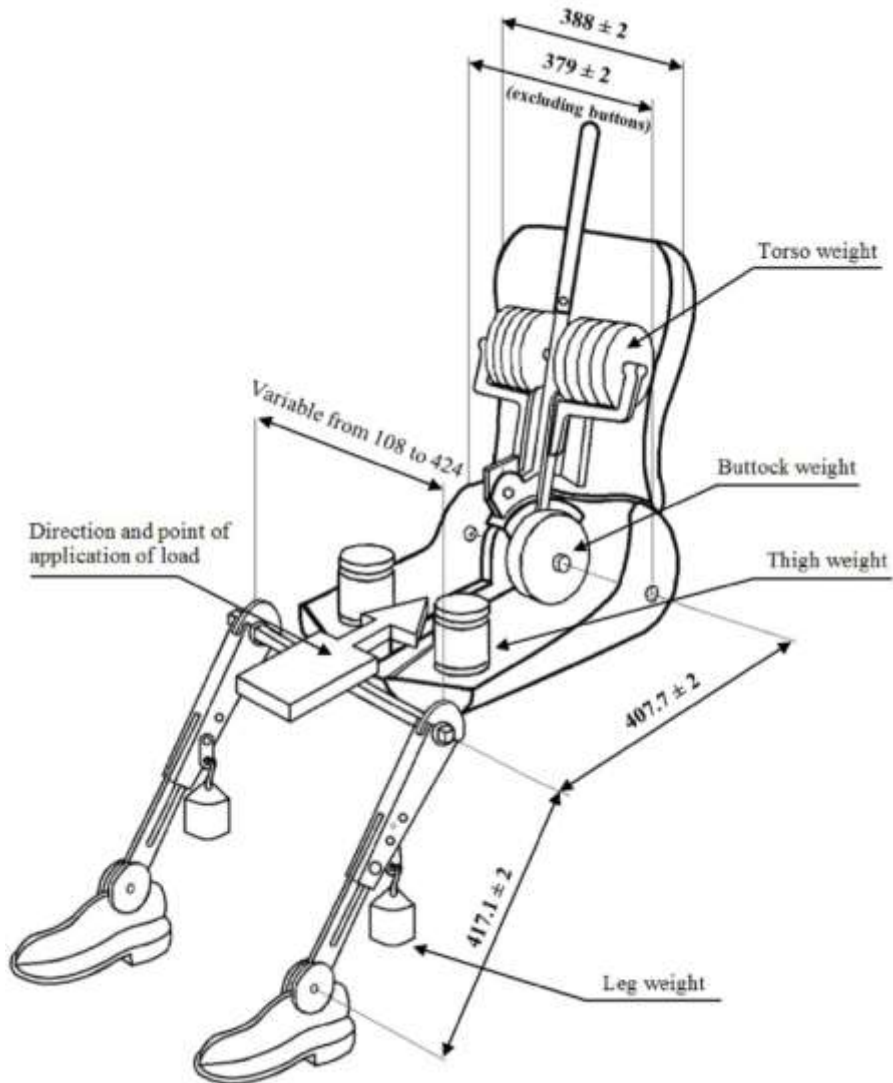

Figure 5-2  
Dimensions of the 3-D H machine elements and load distribution (Dimensions in millimetres)



## Annex 6

### Test conditions and procedures for the assessment of post-crash hydrogen fuel system integrity

1. Purpose  
Determination of compliance with the requirements of paragraph 5.5.2. of this Regulation.
2. Definitions  
For the purposes of this annex:
  - 2.1. "*Enclosed spaces*" indicates the special volumes within the vehicle (or the vehicle outline across openings) that are external to the hydrogen system (storage system, fuel cell system and fuel flow management system) and its housings (if any) where hydrogen may accumulate (and thereby pose a hazard), such as the passenger compartment, luggage compartment and space under the hood.
  - 2.2. "*Luggage compartment*" is the space in the vehicle for luggage and/or goods accommodation, bounded by the roof, hood, floor, side walls, being separated from the passenger compartment by the front bulkhead or the rear bulkhead.
  - 2.3. "*Nominal working pressure (NWP)*" is the gauge pressure that characterizes typical operation of a system. For compressed hydrogen gas containers, NWP is the settled pressure of compressed gas in a fully fuelled container or storage system at a uniform temperature of 15 °C.
3. Preparation, instrumentation and test conditions
  - 3.1. Compressed hydrogen storage systems and downstream piping
    - 3.1.1. Prior to conducting the crash test, instrumentation is installed in the hydrogen storage system to perform the required pressure and temperature measurements if the standard vehicle does not already have instrumentation with the required accuracy.
    - 3.1.2. The hydrogen storage system is then purged, if necessary, following manufacturer directions to remove impurities from the container before filling the storage system with compressed hydrogen or helium gas. Since the storage system pressure varies with temperature, the targeted fill pressure is a function of the temperature. The target pressure shall be determined from the following equation:
$$P_{\text{target}} = \text{NWP} \times (273 + T_o) / 288$$
where NWP is the nominal working pressure (MPa),  $T_o$  is the ambient temperature to which the storage system is expected to settle, and  $P_{\text{target}}$  is the targeted fill pressure after the temperature settles.
    - 3.1.3. The container is filled to a minimum of 95 per cent of the targeted fill pressure and allowed to settle (stabilize) prior to conducting the crash test.
    - 3.1.4. The main stop valve and shut-off valves for hydrogen gas, located in the downstream hydrogen gas piping, are in normal driving condition immediately prior to the impact.

- 3.2. Enclosed spaces
- 3.2.1. Sensors are selected to measure either the build-up of the hydrogen or helium gas or the reduction in oxygen (due to displacement of air by leaking hydrogen/helium).
- 3.2.2. Sensors are calibrated to traceable references to ensure an accuracy of  $\pm 5$  per cent at the targeted criteria of 4 per cent hydrogen or 3 per cent helium by volume in air, and a full scale measurement capability of at least 25 per cent above the target criteria. The sensor shall be capable of a 90 per cent response to a full scale change in concentration within 10 seconds.
- 3.2.3. Prior to the crash impact, the sensors are located in the passenger and luggage compartments of the vehicle as follows:
- (a) At a distance within 250 mm of the headliner above the driver's seat or near the top centre of the passenger compartment;
  - (b) At a distance within 250 mm of the floor in front of the rear (or rear most) seat in the passenger compartment; and
  - (c) At a distance within 100 mm of the top of luggage compartments within the vehicle that are not directly affected by the particular crash impact to be conducted.
- 3.2.4. The sensors are securely mounted on the vehicle structure or seats and protected for the planned crash test from debris, air bag exhaust gas and projectiles. The measurements following the crash are recorded by instruments located within the vehicle or by remote transmission.
- 3.2.5. The test may be conducted either outdoors in an area protected from the wind and possible solar effects or indoors in a space that is large enough or ventilated to prevent the build-up of hydrogen to more than 10 per cent of the targeted criteria in the passenger and luggage compartments.
4. Post-crash leak test measurement for a compressed hydrogen storage system filled with compressed hydrogen
- 4.1. The hydrogen gas pressure,  $P_0$  (MPa), and temperature,  $T_0$  ( $^{\circ}$ C), are measured immediately before the impact and then at a time interval,  $\Delta t$  (min), after the impact.
- 4.1.1. The time interval,  $\Delta t$ , starts when the vehicle comes to rest after the impact and continues for at least 60 minutes.
- 4.1.2. The time interval,  $\Delta t$ , shall be increased if necessary in order to accommodate measurement accuracy for a storage system with a large volume operating up to 70MPa; in that case,  $\Delta t$  can be calculated from the following equation:
- $$\Delta t = V_{CHSS} \times NWP / 1000 \times ((-0.027 \times NWP + 4) \times R_s - 0.21) - 1.7 \times R_s$$
- where  $R_s = P_s / NWP$ ,  $P_s$  is the pressure range of the pressure sensor (MPa),  $NWP$  is the Nominal Working Pressure (MPa),  $V_{CHSS}$  is the volume of the compressed hydrogen storage system (L), and  $\Delta t$  is the time interval (min).
- 4.1.3. If the calculated value of  $\Delta t$  is less than 60 minutes,  $\Delta t$  is set to 60 minutes.
- 4.2. The initial mass of hydrogen in the storage system can be calculated as follows:
- $$P_o' = P_o \times 288 / (273 + T_0)$$
- $$\rho_o' = -0.0027 \times (P_o')^2 + 0.75 \times P_o' + 0.5789$$
- $$M_o = \rho_o' \times V_{CHSS}$$

- 4.3. Correspondingly, the final mass of hydrogen in the storage system,  $M_f$ , at the end of the time interval,  $\Delta t$ , can be calculated as follows:

$$P_f' = P_f \times 288 / (273 + T_f)$$

$$\rho_f' = -0.0027 \times (P_f')^2 + 0.75 \times P_f' + 0.5789$$

$$M_f = \rho_f' \times V_{CHSS}$$

where  $P_f$  is the measured final pressure (MPa) at the end of the time interval, and  $T_f$  is the measured final temperature ( $^{\circ}\text{C}$ ).

- 4.4. The average hydrogen flow rate over the time interval is therefore:

$$V_{H_2} = (M_f - M_o) / \Delta t \times 22.41 / 2.016 \times (P_{\text{target}} / P_o)$$

where  $V_{H_2}$  is the average volumetric flow rate (NL/min) over the time interval and the term  $(P_{\text{target}}/P_o)$  is used to compensate for differences between the measured initial pressure ( $P_o$ ) and the targeted fill pressure ( $P_{\text{target}}$ ).

5. Post-crash leak test measurement for a compressed hydrogen storage system filled with compressed helium

- 5.1. The helium gas pressure,  $P_o$  (MPa), and temperature  $T_o$  ( $^{\circ}\text{C}$ ), are measured immediately before the impact and then at a predetermined time interval after the impact.

- 5.1.1. The time interval,  $\Delta t$ , starts when the vehicle comes to rest after the impact and continues for at least 60 minutes.

- 5.1.2. The time interval,  $\Delta t$ , shall be increased if necessary in order to accommodate measurement accuracy for a storage system with a large volume operating up to 70 MPa; in that case,  $\Delta t$  can be calculated from the following equation:

$$\Delta t = V_{CHSS} \times NWP / 1000 \times ((-0.028 \times NWP + 5.5) \times R_s - 0.3) - 2.6 \times R_s$$

where  $R_s = P_s / NWP$ ,  $P_s$  is the pressure range of the pressure sensor (MPa),  $NWP$  is the Nominal Working Pressure (MPa),  $V_{CHSS}$  is the volume of the compressed storage system (L), and  $\Delta t$  is the time interval (min).

- 5.1.3. If the value of  $\Delta t$  is less than 60 minutes,  $\Delta t$  is set to 60 minutes.

- 5.2. The initial mass of helium in the storage system is calculated as follows:

$$P_o' = P_o \times 288 / (273 + T_o)$$

$$\rho_o' = -0.0043 \times (P_o')^2 + 1.53 \times P_o' + 1.49$$

$$M_o = \rho_o' \times V_{CHSS}$$

- 5.3. The final mass of helium in the storage system at the end of the time interval,  $\Delta t$ , is calculated as follows:

$$P_f' = P_f \times 288 / (273 + T_f)$$

$$\rho_f' = -0.0043 \times (P_f')^2 + 1.53 \times P_f' + 1.49$$

$$M_f = \rho_f' \times V_{CHSS}$$

where  $P_f$  is the measured final pressure (MPa) at the end of the time interval, and  $T_f$  is the measured final temperature ( $^{\circ}\text{C}$ ).

- 5.4. The average helium flow rate over the time interval is therefore:

$$V_{He} = (M_f - M_o) / \Delta t \times 22.41 / 4.003 \times (P_{\text{target}} / P_o)$$

where  $V_{He}$  is the average volumetric flow rate (NL/min) over the time interval and the term  $(P_{target}/P_o)$  is used to compensate for differences between the measured initial pressure ( $P_o$ ) and the targeted fill pressure ( $P_{target}$ ).

- 5.5. Conversion of the average volumetric flow of helium to the average hydrogen flow is done with the following expression:

$$V_{H2} = V_{He} / 0.75$$

where  $V_{H2}$  is the corresponding average volumetric flow of hydrogen.

6. Post-crash concentration measurement for enclosed spaces
- 6.1. Post-crash data collection in enclosed spaces commences when the vehicle comes to a rest. Data from the sensors installed in accordance with paragraph 3.2. of this annex are collected at least every 5 seconds and continue for a period of 60 minutes after the test. A first-order lag (time constant) up to a maximum of 5 seconds may be applied to the measurements to provide "smoothing" and filter the effects of spurious data points.

## Annex 7

### Impact reference line

Figure 7-1  
Vehicle to be impacted on left side (overhead plan view)

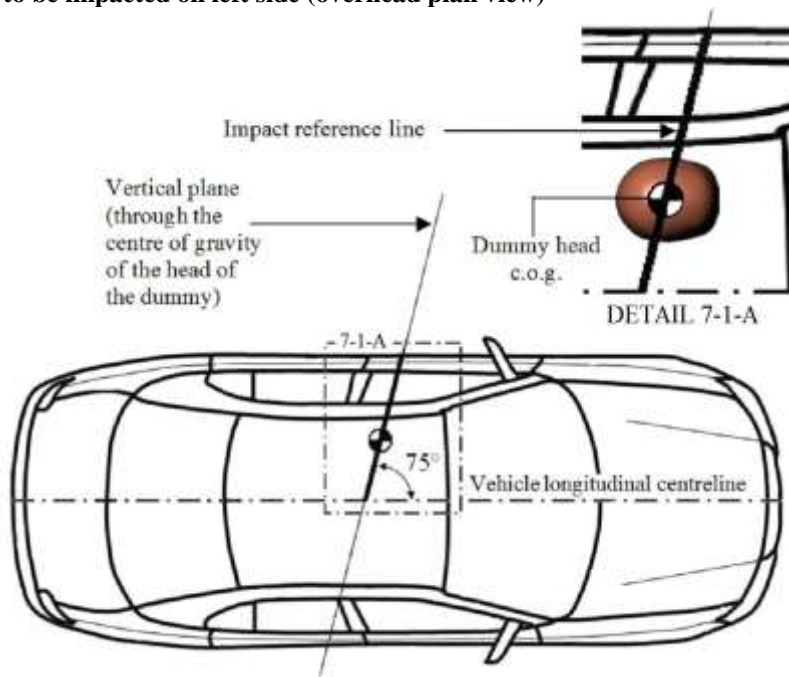
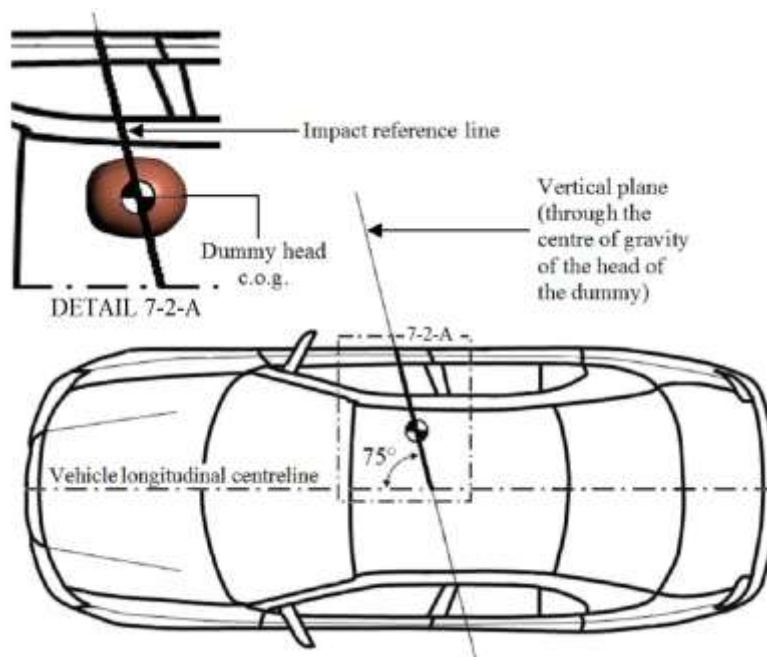

Figure 7-2  
Vehicle to be impacted on right side (overhead plan view)



## Annex 8

### Impact angle

Figure 8-1  
Left side impact (overhead plan view)

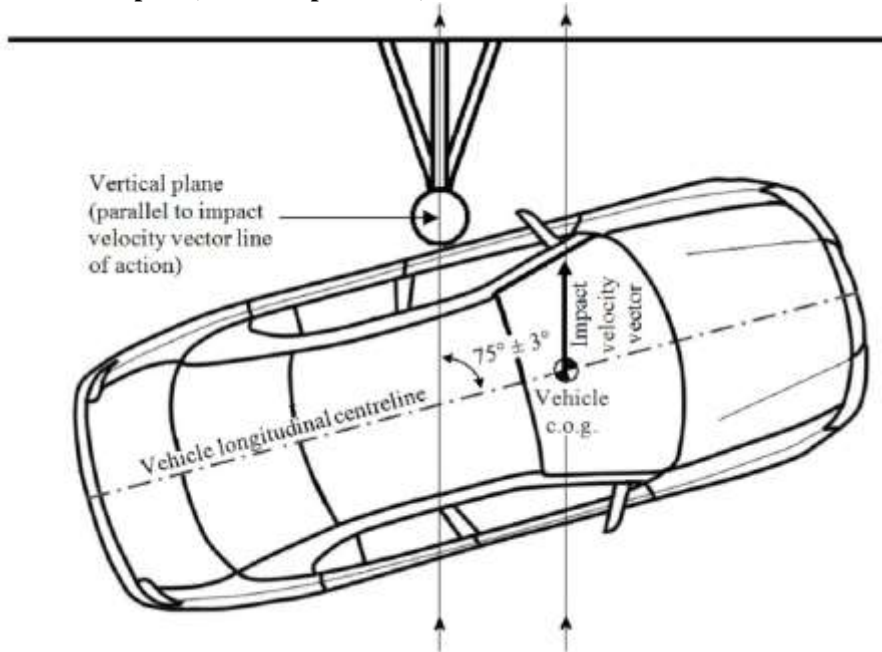
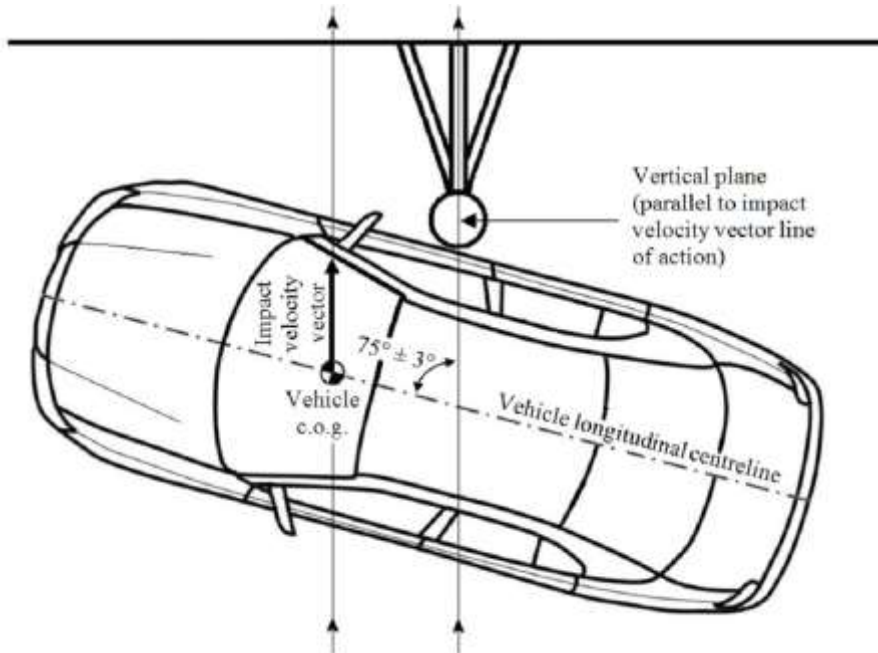

Figure 8-2  
Right side impact (overhead plan view)





## Annex 9

### Pitch and roll angle references

Figure 9-1  
Example of a linear reference connecting two reference points on a left door sill

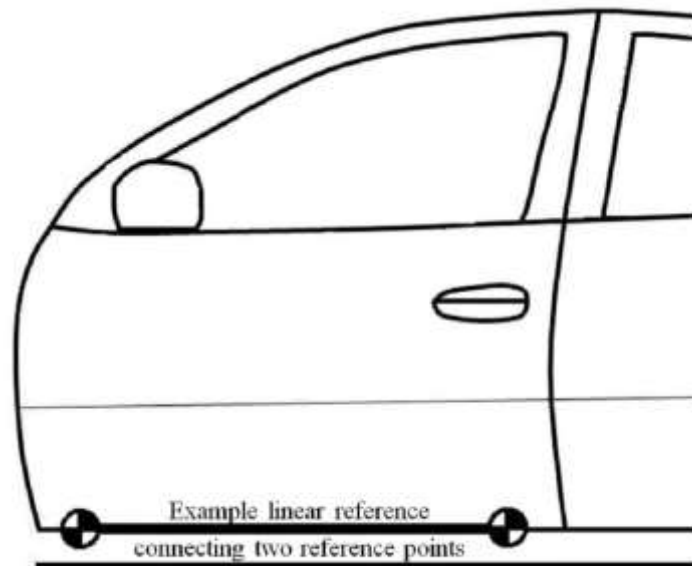
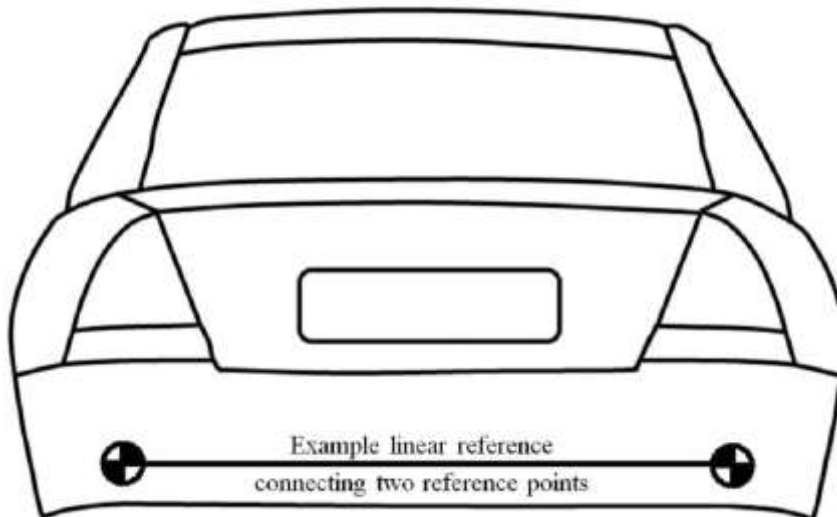

Figure 9-2  
Example of a linear reference connecting two reference points on a rear body



## Annex 10

### Determination of WorldSID 50<sup>th</sup> percentile adult male performance criteria

1. Head Injury Criterion (HIC)
- 1.1. The Head Injury Criterion (HIC) 36 is the maximum value calculated from the expression:

$$\text{HIC36} = \left[ \frac{1}{t_2 - t_1} \int_{t_1}^{t_2} a_R dt \right]^{2.5} (t_2 - t_1)$$

Where:

$a_R$  = the resultant translational acceleration at the centre of gravity of the dummy head recorded versus time in units of gravity,  $g$  ( $1 g = 9.81 \text{ m/s}^2$ ); and

$t_1$  and  $t_2$  are any two points in time during the impact which are separated by not more than a 36 millisecond time interval and where  $t_1$  is less than  $t_2$ .

- 1.2. The resultant acceleration at the centre of gravity of the dummy head is calculated from the expression:

$$a_R = \sqrt{a_x^2 + a_y^2 + a_z^2}$$

Where:

$a_x$  = the longitudinal (x-axis) acceleration at the centre of gravity of the dummy head recorded versus time and filtered at a channel frequency class (CFC)<sup>1</sup> of 1,000 Hz;

$a_y$  = the lateral (y-axis) acceleration at the centre of gravity of the dummy head recorded versus time and filtered at a CFC of 1,000 Hz; and

$a_z$  = the vertical (z-axis) acceleration at the centre of gravity of the dummy head recorded versus time and filtered at a CFC of 1,000 Hz.

2. Shoulder performance criteria
- 2.1. The peak lateral (y-axis) shoulder force is the maximum lateral force measured by the load cell mounted between the shoulder clevis assembly and the shoulder rib doubler and filtered at a CFC of 600 Hz.
3. Thorax performance criteria
- 3.1. The maximum thorax rib deflection is the maximum deflection of any (upper, middle or lower) thorax rib, as determined from the voltage output measurements recorded by the deflection sensor mounted between the rib accelerometer mounting bracket and central spine box mounting bracket inside each struck-side thorax rib, and filtered at a CFC of 600 Hz.

---

<sup>1</sup> For details of each Channel Frequency Class (CFC) refer to SAE Recommended Practice J211/1 (revision December 2003).

4. Abdominal performance criteria
- 4.1. The maximum abdominal rib deflection is the maximum deflection of any (upper or lower) abdominal rib, as determined from the voltage output measurements recorded by the deflection sensor mounted between the rib accelerometer mounting bracket and central spine box mounting bracket inside each struck-side abdominal rib, and filtered at a CFC of 600 Hz.
- 4.2. The value of the resultant lower spine (T12) acceleration ( $a_R$ ) which is exceeded for 3 milliseconds cumulatively (i.e. across one or more peaks) is calculated from the expression:

$$a_R = \sqrt{a_x^2 + a_y^2 + a_z^2}$$

Where:

$a_x$  = the longitudinal (x-axis) acceleration of the dummy lower spine recorded versus time and filtered at a CFC of 180 Hz;

$a_y$  = the lateral (y-axis) acceleration of the dummy lower spine recorded versus time and filtered at a CFC of 180 Hz; and

$a_z$  = the vertical (z-axis) acceleration of the dummy lower spine recorded versus time and filtered at a CFC of 180 Hz.

5. Pelvis performance criteria
  - 5.1. The peak pubic symphysis force is the maximum force measured by the load cell at the pubic symphysis of the pelvis and filtered at a CFC of 600 Hz.
-