

27 November 2013

Agreement

Concerning the Adoption of Uniform Technical Prescriptions for Wheeled Vehicles, Equipment and Parts which can be Fitted and/or be Used on Wheeled Vehicles and the Conditions for Reciprocal Recognition of Approvals Granted on the Basis of these Prescriptions*

(Revision 2, including the amendments which entered into force on 16 October 1995)

Addendum 50: Regulation No. 51

Revision 2 – Amendment 2

Supplement 9 to the 02 series of amendments - Date of entry into force: 3 November 2013

Uniform provisions concerning the approval of motor vehicles having at least four wheels with regard to their noise emissions



UNITED NATIONS

* Former title of the Agreement: Agreement Concerning the Adoption of Uniform Conditions of Approval and Reciprocal Recognition of Approval for Motor Vehicle Equipment and Parts, done at Geneva on 20 March 1958.

Annex 3,

Appendix,

Figure 2, amend to read:

"Figure 2

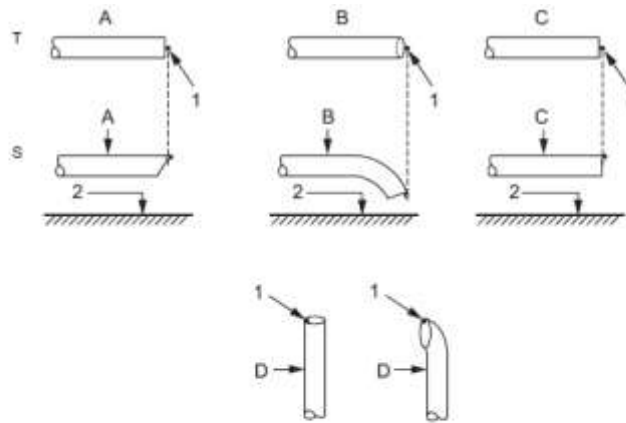

Key

T top view

S side view

1 reference point

2 road surface

A mitered pipe

B bent down pipe

C straight pipe

D vertical pipe

"