

23 June 2014

Agreement

Concerning the Adoption of Uniform Technical Prescriptions for Wheeled Vehicles, Equipment and Parts which can be Fitted and/or be Used on Wheeled Vehicles and the Conditions for Reciprocal Recognition of Approvals Granted on the Basis of these Prescriptions*

(Revision 2, including the amendments which entered into force on 16 October 1995)

Addendum 48 – Regulation No. 49

Revision 5 - Amendment 3

Supplement 6 to the 05 series of amendments – Date of entry into force: 10 June 2014

Uniform provisions concerning the measures to be taken against the emission of gaseous and particulate pollutants from compression-ignition engines and positive ignition engines for use in vehicles



UNITED NATIONS

* Former title of the Agreement: Agreement Concerning the Adoption of Uniform Conditions of Approval and Reciprocal Recognition of Approval for Motor Vehicle Equipment and Parts, done at Geneva on 20 March 1958.

Paragraph 1.1., Table A, amend to read (also inserting a new footnote d):

"Table A
Applicability

Vehicle category ¹	Positive-ignition engines			Dual-fuel engines	Compression-ignition engines	
	Petrol	NG ^a	LPG ^b		Diesel	Ethanol
M ₁	R49 or R83 ^c	R49 or R83 ^c	R49 or R83 ^c	R49 ^d	R49 or R83 ^c	R49 or R83 ^c
M ₂	R49 or R83 ^c	R49 or R83 ^c	R49 or R83 ^c		R49 or R83 ^c	R49 or R83 ^c
M ₃	R49	R49	R49		R49	R49
N ₁	R49 or R83 ^c	R49 or R83 ^c	R49 or R83 ^c		R49 or R83 ^c	R49 or R83 ^c
N ₂	R49 or R83 ^c	R49 or R83 ^c	R49 or R83 ^c		R49 or R83 ^c	R49 or R83 ^c
N ₃	R49	R49	R49		R49	R49

¹ As defined in the Consolidated Resolution on the Construction of Vehicles (R.E.3), document ECE/TRANS/WP.29/78/Rev.3, para.2

^a Natural Gas.

^b Liquefied Petroleum Gas.

^c Regulation No. 83 applies for vehicles with a reference mass ≤ 2,610 kg and by extension of an approval for vehicles with a reference mass ≤ 2,840 kg

^d The provisions related to dual-fuel engines and vehicles contained into Regulation No. 49 only apply for vehicles and engines within the scope of rev.5 of that Regulation"

Paragraph 1.1., Table B, amend to read (also inserting new footnote c):

"Table B
Requirements

	Positive-ignition engines			Dual-fuel Engines ^c	Compression-ignition engines	
	Petrol	NG	LPG		Diesel	Ethanol
Gaseous pollutants	-	Yes	Yes	Yes	Yes	Yes
Particulates	-	Yes ^a	Yes ^a	Yes	Yes	Yes
Smoke	-	-	-	Yes	Yes	Yes
Durability	-	Yes	Yes	Yes	Yes	Yes
In-service-conformity	-	Yes	Yes	Yes	Yes	Yes
OBD	-	Yes ^b	Yes ^b	Yes	Yes	Yes

^a Only applicable to stage C in Table 2 of paragraph 5.2.1.

^b Application dates according to paragraph 5.4.2.

^c According to the requirements of Annex 11. "

Insert a new paragraph 1.2.1., to read:

"1.2.1. Equivalent approval as set out in paragraph 1.2. shall not be granted in the case of dual-fuel engines and vehicles (see definitions in paragraph 2. of this Regulation)."

Insert new paragraphs 2.1.15. to 2.1.19., to read:

- "2.1.15. "Diesel mode" means the normal operating mode of a dual-fuel engine during which the engine does not use any gaseous fuel for any engine operating condition.
- 2.1.16. "Driving cycle" means a sequence consisting of an engine start, an operating period (of the vehicle), an engine shut-off, and the time until the next engine start.
- 2.1.17. "Dual-fuel engine" means an engine system that is designed to simultaneously operate with diesel fuel and a gaseous fuel, both fuels being metered separately, where the consumed amount of one of the fuels relative to the other one may vary depending on the operation.
- 2.1.18. "Dual-fuel mode" means the normal operating mode of a dual-fuel engine during which the engine simultaneously uses diesel fuel and a gaseous fuel at some engine operating conditions.
- 2.1.19. "Dual-fuel vehicle" means a vehicle that is powered by a dual-fuel engine and that supplies the fuels used by the engine from separate on-board storage systems."

Paragraphs 2.1.15. (former) to 2.1.35. (former), renumber as paragraphs 2.1.20. to 2.1.40.

Insert a new paragraph 2.1.41., to read:

- "2.1.41. "LNG₂₀" means a specific liquefied natural gas / liquefied biomethane composition resulting in a λ -shift factor not differing by more than 3 per cent the λ -shift factor of the G₂₀ gas specified in Annex 5, and the ethane content of which does not exceed 1.5 per cent."

Paragraphs 2.1.36. (former) to 2.1.56. (former), renumber as paragraphs 2.1.42. to 2.1.62.

Insert a new paragraph 2.1.63., to read:

- "2.1.63. "Service mode" means a special mode of a dual-fuel engine that is activated for the purpose of repairing, or of moving the vehicle from the traffic when operation in the dual-fuel mode is not possible."

Paragraphs 2.1.57. (former) to 2.1.66. (former), renumber as paragraphs 2.1.64. to 2.1.73.

Paragraph 2.2.3., amend to read:

"2.2.3.	Abbreviations	
	CFV	Critical flow venturi
	CLD	Chemiluminescent detector
	CNG	Compressed Natural Gas
	ELR	European load response test
	ESC	European steady state cycle
	ETC	European transient cycle
	FID	Flame ionisation detector
	GC	Gas chromatograph
	HCLD	Heated chemiluminescent detector

HFID	Heated flame ionisation detector
LPG	Liquefied petroleum gas
LNG	Liquefied Natural Gas
NDIR	Non-dispersive infrared analyzer
NG	Natural gas
NMC	Non-methane cutter"

Paragraph 4.1.1., amend to read:

"4.1.1. In the case of diesel, ethanol, or LNG₂₀ fuel the parent engine meets the requirements of this Regulation on the reference fuel specified in Annex 5."

Insert a new paragraph 4.1.1.1., to read:

"4.1.1.1. In the case of a dual-fuel engine family the parent engine meets in addition the requirements set out in Annex 11 on the reference fuels specified in Annex 5."

Paragraph 4.1.2., amend to read:

"4.1.2. In the case of CNG the parent engine, including in the case of a dual-fuel engine family, should demonstrate its capability to adapt to any fuel composition that may occur across the market. ..."

Paragraph 4.1.3., amend to read:

"4.1.3. In the case of a CNG engine, including a dual-fuel engine, which is self-adaptive for the range of H-gases on the one hand and the range of L-gases on the other hand, and which switches between the H-range and the L-range by means of a switch, the parent engine shall be tested on the relevant reference fuel as specified in Annex 5 for each range, at each position of the switch. ..."

Paragraph 4.1.4., amend to read:

"4.1.4. In the case of CNG engines, including dual-fuel engines, the ratio of the emission results "r" shall be determined for each pollutant as follows:
..."

Paragraph 4.1.5., amend to read:

"4.1.5. In the case of LPG the parent engine, including in the case of a dual-fuel engine family, should demonstrate its capability to adapt to any fuel composition that may occur across the market. In the case of LPG there are variations in C₃/C₄ composition. ..."

Insert a new paragraph 4.1.6., to read:

"4.1.6. In the case of LNG the parent engine, including in the case of a dual-fuel engine family but excluding the case of LNG₂₀, shall meet the requirements of this Regulation on the reference fuels G_R (fuel 1) and G₂₀ (fuel 2), as specified in Annex 5, without any manual readjustment to the engine fuelling system between the two tests (self-adaptation is required). One adaptation run over one ETC cycle without measurement is permitted after the change of the fuel."

Paragraph 4.2.1., amend to read:

- "4.2.1. Exhaust emissions approval of an engine running on CNG and laid out for operation on either the range of H-gases or on the range of L-gases
- The parent engine, including in the case of a dual-fuel engine, shall be tested on the relevant reference fuel, as specified in Annex 5, for the relevant range. The fuels are G_R (fuel 1) and G_{23} (fuel 3) for the H-range of gases and G_{25} (fuel 2) and G_{23} (fuel 3) for the L-range of gases. ..."

Paragraphs 4.2.2 and 4.2.2.1., amend to read:

- "4.2.2. Exhaust emissions approval of an engine running on CNG or LPG and laid out for operation on one specific fuel composition
- 4.2.2.1. The parent engine, including in the case of a dual-fuel engine, shall meet the emission requirements on the reference fuels G_R and G_{25} in the case of natural gas, or the reference fuels A and B in the case of LPG, as specified in Annex 5. Between the tests fine-tuning of the fuelling system is allowed. ..."

Insert a new paragraph 4.2.3., to read:

- "4.2.3. In the case of a dual-fuel engine family the parent engine shall meet in addition the requirements set out in Annex 11 on the reference fuels specified in Annex 5."

First table after paragraph 4.2.3., the title, amend to read:

"Approval of CNG-fuelled engines"

Insert new paragraphs 4.6.3.1.7. and 4.6.3.1.8., to read:

- "4.6.3.1.7. LNG₂₀ in case of the engine being approved and calibrated for a specific LNG composition resulting in a λ -shift factor not differing by more than 3 per cent the λ -shift factor of the G_{20} gas specified in Annex 9, and the ethane content of which does not exceed 1.5 per cent.
- 4.6.3.1.8. LNG in case of the engine being approved and calibrated for any other LNG composition."

Insert a new paragraph 4.6.3.2., to read:

- "4.6.3.2. For dual-fuel engines, the approval mark shall contain a series of digits after the national symbol, the purpose of which is to distinguish for which dual-fuel engine type and with which range of gases the approval has been granted. The series of digits will be constituted of two digits for the dual-fuel engine Type defined in Annex 11, followed by the letter(s) specified in paragraph 4.6.3.1. The two digits identifying the dual-fuel engine Types defined in Annex 11 are the following:
- (a) 1A for dual-fuel engines of Type 1A, type as defined in Annex 11;
 - (b) 1B for dual-fuel engines of Type 1B, type as defined in Annex 11;
 - (c) 2B for dual-fuel engines of Type 2B, type as defined in Annex 11;
 - (d) 3B for dual-fuel engines of Type 3B, type as defined in Annex 11."

Paragraphs 4.11. and 4.11.1., amend to read:

"4.11. Labels

In the case of CNG and LPG fuelled engines with a fuel range restricted type approval, and in the case of LNG₂₀ engines, the following labels are applicable, including in the case of dual-fuel engines:

4.11.1. Content

The following information shall be given:

In the case of an engine fuelled with LNG₂₀., the label shall state "ONLY FOR USE WITH LNG₂₀"

In the case of paragraph 4.2.1.3., the label shall state "ONLY FOR USE WITH NATURAL GAS RANGE H". If applicable, "H" is replaced by "L".

..."

Insert new paragraphs 5.6. and 5.6.1., to read:

"5.6. Requirements related to dual-fuel engines and vehicles

5.6.1. Dual-fuel engine and vehicles shall in addition meet the requirements set out in Annex 11 to this Regulation. In case of contradiction, the requirements set out in Annex 11 shall have precedence over those set out in paragraphs 5.1. to 5.5. of this Regulation."

Insert new paragraphs 6.2. and 6.2.1., to read:

"6.2. Requirements related to dual-fuel engines and vehicles

6.2.1. Notwithstanding the requirements set out in paragraph 6.1. of this Regulation, dual-fuel engines and vehicles shall in addition meet the requirements set out in Annex 11 to this Regulation."

Paragraph 8.3.1.1., amend to read:

"8.3.1.1. Three engines are randomly taken in the series. Engines that are subject to testing only on the ESC and ELR tests or only on the ETC test for type approval to row A of the tables in paragraph 5.2.1. are subject to those applicable tests for the checking of production conformity. With the agreement of the authority, all other engines type approved to row A, B1 or B2, or C of the tables in paragraph 5.2.1. are subjected to testing either on the ESC and ELR cycles or on the ETC cycle for the checking of the production conformity. The limit values are given in paragraph 5.2.1. of this Regulation, or, in the case of a dual-fuel engine, in Annex 11 of this Regulation."

Insert a new paragraph 8.3.1.1.1., to read:

"8.3.1.1.1. Dual-fuel engines are tested in dual-fuel mode. When a diesel mode is available, dual-fuel engines shall also be tested in diesel mode. In that case, the test shall be performed just before or just after the test in dual-fuel mode, on the same engine, on the same engine test-bed, and under the same laboratory conditions."

Paragraph 8.3.1.3., amend to read:

"8.3.1.3. On the basis of a test of the engine by sampling, the production of a series is regarded as conforming where a pass decision is reached for all the pollutants and non-conforming where a fail decision is reached for one pollutant, in accordance with the test criteria applied in the appropriate appendix.

In the case of dual-fuel engines tested both in dual-fuel and diesel mode, the production of a series is regarded as conforming where a pass decision is reached for all the pollutants in both dual-fuel and diesel modes and non-conforming where a fail decision is reached for one pollutant in either of the operating modes.

When a pass decision has been reached for one pollutant, this decision may not be changed by any additional tests made in order to reach a decision for the other pollutants.

..."

Insert a new paragraph 8.3.2.5.1., to read:

"8.3.2.5.1. In the case of dispute caused by the non-compliance of engines approved for operating on LNG₂₀, including dual-fuel engines, when using a market fuel, the tests shall be performed with G₂₀, as specified in Annex 5."

Annex 1,

Appendices 1 and 3,

Paragraph 1.13., amend to read (leaving footnote 2 unchanged):

"1.13. Combustion system: compression ignition/positive ignition/dual fuel²"

Insert new paragraphs 1.13.1. to 1.13.3. (including footnote 4), to read:

1.13.1. Type of dual-fuel engine: Type 1A/Type 1B/Type 2B/Type 3B^{2,4}

1.13.2. Gas Energy Ratio over the ETC test-cycle: %⁴

1.13.3. Idle on diesel: yes/no^{2,4}

1.13.4. When appropriate, manufacturer reference of the documentation for installing the dual-fuel engine in a vehicle⁴

⁴ In case of a dual-fuel engine or vehicle (types as defined in Annex 11)."

Paragraph 1.14., amend (also adding footnote 5) to read:

"1.14. Fuel: Diesel/LPG/NG-H/NG-L/NG-HL/ethanol/LNG/LNG₂₀^{2,5}

⁵ In case of a dual-fuel engine or vehicle, the type of gaseous fuel used in dual-fuel mode shall not be struck out."

Paragraph 3.1., amend to read:

"3.1. Diesel engines, including dual-fuel engines"

Paragraph 3.2., amend (also changing footnote reference number from 4 to 6) to read:

"3.2. Gas fuelled engines, including dual-fuel engines⁶

⁶ In the case of systems laid-out in a different manner, supply equivalent information (for paragraph 3.2.)."

Appendix 1,

Paragraph 8.1., amend (also changing footnote reference number from 5 to 7) and add footnote 8, to read:

"8.1. Engine speeds^{7,8}

⁷ Specify the tolerance; to be within ± 3 per cent of the values declared by the manufacturer.

⁸ In the case of Type 1B, Type 2B, and Type 3B of dual-fuel engines (types as defined in Annex 11) , repeat the information in both dual-fuel and diesel mode."

Add a new paragraph 8.2.1. (including references to footnotes 4 and 8) to read:

"8.2.1 Declared values for power test according to Regulation No. 85 or declared values for power test in dual-fuel mode according to Regulation No. 85^{4,8}

Idle speed..... rpm

Speed at maximum power..... rpm

Maximum power..... kW

Speed at maximum torque..... rpm

Maximum torque..... Nm"

Annex 4A,

Paragraph 1.3., amend to read:

"1.3. Measurement principle

The emissions to be measured from the exhaust of the engine include the gaseous components (carbon monoxide, total hydrocarbons for diesel and type 3B dual-fuel engines on the ESC test only; non-methane hydrocarbons for diesel, dual-fuel and gas engines on the ETC test only; methane for gas and dual-fuel engines on the ETC test only and oxides of nitrogen), the particulates (diesel and dual-fuel engines only) and smoke (diesel and dual-fuel engines on the ELR test only). Additionally, carbon dioxide is often used as a tracer gas for determining the dilution ratio of partial and full flow dilution systems. Good engineering practice recommends the general measurement of carbon dioxide as an excellent tool for the detection of measurement problems during the test run."

Paragraph 2.1.1., amend to read:

"2.1.1. ...

(a) For compression-ignition and dual-fuel engines:

..."

Appendix 1,

Paragraph 4.1.2., amend to read:

"4.1.2. Air and fuel measurement method

This involves measurement of the air flow and the fuel flow. Air flowmeters and fuel flowmeters shall be used that meet the total accuracy requirement of paragraph 4.1. The calculation of the exhaust gas flow is as follows:

$$q_{mew} = q_{maw} + q_{mf}$$

In case of dual-fuel engines operating in dual-fuel mode, the fuel flows for both the gaseous and the diesel fuel shall be measured and their masses added."

Paragraph 5.2., amend to read:

"5.2. Dry / wet correction

The measured concentration shall be converted to a wet basis according to the following formulae, if not already measured on a wet basis. The conversion shall be done for each individual mode.

The u_{gas} -values and molar ratios as described in paragraphs A.5.2. and A.5.3. of Appendix 5 to Annex 11 shall be used for dual-fuel engines, operating in dual-fuel mode,

$$c_{wet} = k_W \times c_{dry}$$

..."

Paragraph 6.2., amend to read:

"6.2. Partial flow dilution system

The final reported test results of the particulate emission shall be determined through the following steps. Since various types of dilution rate control may be used, different calculation methods for q_{medf} apply. All calculations shall be based upon the average values of the individual modes during the sampling period.

In case of dual-fuel engines operating in dual-fuel mode, the exhaust mass flow shall be determined according to the direct measurement method as specified in 6.2.4."

Paragraph 6.3., amend to read:

"6.3. Full flow dilution system

All calculations shall be based upon the average values of the individual modes during the sampling period. The diluted exhaust gas flow q_{mdew} shall be determined in accordance with paragraph 4.1. of Appendix 2 to this annex. The total sample mass m_{sep} shall be calculated in accordance with paragraph 6.2.1. of Appendix 2 to this annex.

In case of dual-fuel engines operating in dual-fuel mode, the calculations shall be performed according to Appendix 4 to Annex 11."

Appendix 2,

Paragraph 3.4., amend to read:

"3.4. Starting the particulate sampling system (diesel and dual-fuel engines only)
..."

Paragraph 4.2., amend to read:

"4.2. Determination of raw exhaust gas mass flow

For calculation of the emissions in the raw exhaust gas and for controlling of a partial flow dilution system, it is necessary to know the exhaust gas mass flow rate. For the determination of the exhaust mass flow rate, either of the methods described in paragraphs 4.2.2. to 4.2.5. of this appendix may be used.

Only the direct measurement of the exhaust flow is applicable for dual-fuel engines operating in dual-fuel mode. The use of the air and fuel measurement method is not allowed in this mode."

Paragraph 5., amend to read:

"5. Calculation of the gaseous emissions

The calculation procedures as specified in Annex 4B as adapted in Appendix 4 to Annex 11 shall be used for dual-fuel engines operating in dual-fuel mode."

Paragraph 6., amend to read:

"6. Calculation of the particulate emission (if applicable)

The calculation procedures as specified in Annex 4B as adapted in Appendix 4 to Annex 11 shall be used for dual-fuel engines operating in dual-fuel mode."

Annex 4B,

Paragraph 1., amend to read:

"1. Applicability

This annex is not applicable for the purpose of type approval according to this Regulation for the time being. It will be made applicable in the future.

This Annex is applicable for dual-fuel engines when referenced from Annex 4A or Appendix 4 to Annex 11."

Appendix 3,

Figure 14, amend to read:

"Figure 14

Scheme of hatted probe

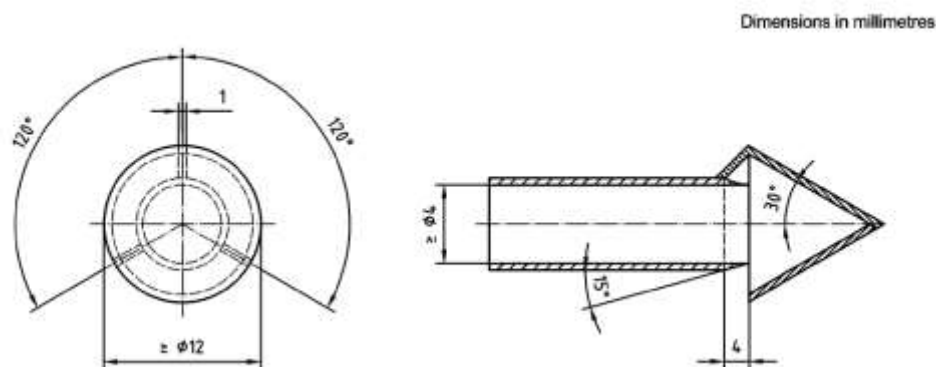

Annex 5,

Paragraph 1.2., amend to read:

"1.2. Diesel reference fuel for testing engines to the emission limits given in rows B1, B2 or C of the tables in paragraph 5.2.1. of this Regulation and dual-fuel engines"

Paragraph 2., amend to read:

"2. Compressed natural gas (NG) - European market fuels are available in two ranges:

- (a) The H range, whose extreme reference fuels are G_R and G_{23} ;
- (b) The L range, whose extreme reference fuels are G_{23} and G_{25} .

Liquefied Natural gas – European market fuels are available in a range whose extreme reference fuels are G_{20} and G_R

The characteristics of G_R , G_{20} , G_{23} and G_{25} reference fuels are summarized below:

Reference fuel G_R					
Characteristics	Units	Basis	Limits		Test method
			Minimum	Maximum	
Composition:					
Methane	% mole	87	84	89	
Ethane	% mole	13	11	15	
Balance ^a	% mole	-	-	1	ISO 6974
Sulphur content	mg/m ³ ^b	-	-	10	ISO 6326-5

^a Inerts +C₂₊

^b Value to be determined at standard conditions (293.2 K (20 °C) and 101.3 kPa).

<i>Reference fuel G₂₀</i>					
<i>Characteristics</i>	<i>Units</i>	<i>Basis</i>	<i>Limits</i>		<i>Test method</i>
			<i>Minimum</i>	<i>Maximum</i>	
...
<i>Reference fuel G₂₀</i>					
Composition:					
Methane	% mole	100	99	100	ISO 6974
Balance ⁽¹⁾	% mole	—	—	1	ISO 6974
N ₂	% mole				ISO 6974
Sulphur content	mg/m ³ ⁽²⁾	—	—	10	ISO 6326-5
Wobbe Index (net)	MJ/m ³ ⁽³⁾	48.2	47.2	49.2	

⁽¹⁾ Inerts (different from N₂) + C₂ + C₂₊.

⁽²⁾ Value to be determined at 293,2 K (20 °C) and 101,3 kPa.

⁽³⁾ Value to be determined at 273,2 K (0 °C) and 101,3 kPa.

<i>Reference fuel G₂₃</i>					
<i>Characteristics</i>	<i>Units</i>	<i>Basis</i>	<i>Limits</i>		<i>Test method</i>
			<i>Minimum</i>	<i>Maximum</i>	
Composition:					
Methane	% mole	92.5	91.5	93.5	
Balance ^a	% mole	-	-	1	ISO 6974
N ₂		7.5	6.5	8.5	
Sulphur content	mg/m ^{3b}	-	-	10	ISO 6326-5

^a Inerts (different from N₂) + C₂₊ / C₂₊

^b Value to be determined at standard conditions (293.2 K (20 °C) and 101.3 kPa).

<i>Reference fuel G₂₅</i>					
<i>Characteristics</i>	<i>Units</i>	<i>Basis</i>	<i>Limits</i>		<i>Test method</i>
			<i>Minimum</i>	<i>Maximum</i>	
Composition:					
Methane	% mole	86	84	88	
Balance ^a	% mole	-	-	1	ISO 6974
N ₂		14	12	16	
Sulphur content	mg/m ^{3b}	-	-	10	ISO 6326-5

^a Inerts (different from N₂) + C₂₊ / C₂₊

^b Value to be determined at standard conditions (293.2 K (20 °C) and 101.3 kPa).

Insert a new Annex, to read:

"Annex 11

Technical requirements for dual fuel engines and vehicles

1. Scope

This annex shall apply to dual fuel engines and vehicles. Per definition these engines and vehicles are fuelled with diesel and a gaseous fuel.

Notwithstanding the provisions regarding multi-setting engines set-out in paragraph 5.1.2.1. of this Regulation, dual-fuel and service modes as described in this annex are permitted.
2. Definitions and abbreviations
 - 2.1. "*Gas Energy Ratio (GER)*" means in case of a dual-fuel engine, the ratio of the energy content of the gaseous fuel divided by the energy content of both fuels (diesel and gaseous), expressed as a percentage, the energy content of the fuels being defined as the lower heating value.
 - 2.2. "*Average gas ratio*" means the average Gas Energy Ratio calculated over a driving cycle.
 - 2.3. "*Type 1A dual-fuel engine*" means a dual-fuel engine that operates over the ETC test-cycle with an average gas ratio that is not lower than 90 per cent ($GER_{ETC} \geq 90 \%$), and that does not idle using exclusively diesel fuel, and that has no diesel mode.
 - 2.4. "*Type 1B dual-fuel engine*" means a dual-fuel engine that operates over the ETC test-cycle with an average gas ratio that is not lower than 90 per cent ($GER_{ETC} \geq 90 \%$), and that does not idle using exclusively diesel fuel in dual-fuel mode, and that has a diesel mode.
 - 2.5. "*Type 2B dual-fuel engine*"¹ means a dual-fuel engine that operates over the ETC test-cycle with an average gas ratio between 10 per cent and 90 per cent ($10 \% < GER_{ETC} < 90 \%$) and that has a diesel mode, or a dual-fuel engine that operates over the ETC test-cycle with an average gas ratio that is not lower than 90 per cent ($GER_{ETC} \geq 90 \%$), but that can idle using exclusively diesel fuel in dual-fuel mode, and that has a diesel mode.
 - 2.6. "*Type 3B dual-fuel engine*"² means a dual-fuel engine that operates over the ETC test-cycle with an average gas ratio that does not exceed 10 per cent ($GER_{ETC} \leq 10 \%$) and that has a diesel mode.
3. Dual-fuel specific additional approval requirements
 - 3.1. Dual-fuel engine family
 - 3.1.1. Criteria for belonging to a dual-fuel engine family

¹ Type 2A dual-fuel engines and vehicles are neither defined nor allowed by this Regulation.

² Type 3A dual-fuel engines and vehicles are neither defined nor allowed by this Regulation.

All engines within a dual-fuel engine family shall belong to the same type of dual-fuel engines defined in paragraph 2. and operate with the same types of fuel or when appropriate with fuels declared according to this Regulation as being of the same range(s).

All engines within a dual-fuel engine family shall meet the criteria defined by this Regulation for belonging to a compression ignition engine family.

The difference between the highest and the lowest GER_{ETC} (i.e. the highest GER_{ETC} minus the lowest GER_{ETC}) within a dual-fuel engine family shall not exceed 30 per cent.

3.1.2. Selection of the parent engine

The parent engine of a dual-fuel engine family shall be selected according to the criteria defined by this Regulation for selecting the parent engine of a compression ignition engine family.

3.1.3. Extension to include a new engine system into a dual-fuel engine-family

At the request of the manufacturer and upon approval of the Type Approval Authority, a new dual-fuel engine may be included as a member of a certified dual-fuel engine family if the criteria specified in paragraph 3.2.2.1. are met.

If the elements of design of the parent engine system are representative of those of the new engine system, then the parent engine system shall remain unchanged and the manufacturer shall modify the documentation package according to paragraph 12. of this annex.

If the new engine system contains elements of design that are not represented by the parent engine system but itself would represent the whole family, then the new engine system shall become the new dual-fuel-parent engine. In this case the new elements of design shall be demonstrated to comply with the provisions of this regulation, and the documentation package shall be modified according to paragraph 12. of this annex.

3.1.4. Extension to address a design change that affects the dual-fuel engine system

At the request of the manufacturer and upon approval of the Type Approval Authority, an extension of an existing certificate may be granted in the case of a design change of the dual-fuel engine system if the manufacturer demonstrates that the design changes comply with the provisions of this annex.

The documentation package shall be modified according to paragraph 12. of this annex.

4. General requirements

4.1. Operating modes of dual-fuel engines and vehicles

4.1.1. Conditions for a dual-fuel engine to operate in diesel mode

A dual-fuel engine may only operate in diesel mode if, when operating in diesel mode, it has been certified according to all the requirements of this Regulation concerning diesel engines.

4.1.2. Conditions for a dual-fuel engine to idle using diesel fuel exclusively

4.1.2.1. Type 1A dual-fuel engines shall not idle using diesel fuel exclusively except under the conditions defined in paragraph 4.1.3. for warm-up and start.

- 4.1.2.2. Type 1B dual-fuel engines shall not idle using diesel fuel exclusively in dual-fuel mode.
- 4.1.2.3. Types 2B and 3B dual-fuel engines may idle using diesel fuel exclusively.
- 4.1.3. Conditions for a dual-fuel engine to warm-up or start using diesel fuel exclusively
- 4.1.3.1. A Type 1B, Type 2B, or Type 3B dual-fuel engine may warm-up or start using diesel fuel solely. However, in that case, it shall operate in diesel mode.
- 4.1.3.2. A Type 1A dual-fuel engine may warm-up or start using diesel fuel solely. However, in that case, the strategy shall be declared as an AECS and the following additional requirements shall be met:
- 4.1.3.2.1. The strategy shall cease to be active when the coolant temperature has reached a temperature of 343 K (70 °C), or within 15 minutes after it has been activated, whichever occurs first; and
- 4.1.3.2.2. The service mode shall be activated while the strategy is active or, in absence of service mode, the vehicle shall remain stationary.
- 4.2. Operability restriction
- For the purpose of this annex, a dual-fuel vehicle shall be designed so as to permit, at the choice of the manufacturer, one of the following operability restrictions:
- (a) The activation of the service mode;
- (b) The inability for the engine to move the vehicle.
- 4.2.1 Conditions for dual-fuel engines and vehicles to operate in service mode
- When a dual-fuel engine operates in a service mode, the speed of the dual-fuel vehicle equipped with that engine shall be automatically limited to 20 km/h. This speed limitation shall be automatically deactivated when the vehicle no longer operates in service mode. When operating in service mode a dual-fuel engine is temporarily exempted from complying with the requirements related to exhaust emissions, OBD, and NO_x control monitoring described in this Regulation.
- 4.2.2. Requirements regarding operability restriction
- 4.2.2.1. Operability restriction and requirements to ensure the correct operation of NO_x control measures
- An operability restriction as set out in paragraph 4.2. shall not be deactivated by either the activation or deactivation of the warning and torque reduction systems specified in paragraph 5.5.5. of this Regulation.
- The activation and the deactivation of an operability restriction as set out in paragraph 4.2. shall not activate or deactivate the warning and torque reduction systems specified in paragraph 5.5.5. of this Regulation
- 4.2.2.2. Activation of an operability restriction
- In the case where an operability restriction is required according to paragraph 4.2.3. "Unavailability of gaseous fuel when operating in a dual-

fuel mode" because of a malfunction of the gas supply system, the operability restriction shall become active after the next time the vehicle is stationary³ or within 30 minutes after the operability restriction is required, whichever comes first.

In the case where the operability restriction is required because of an empty gas tank, the operability restriction shall become active as soon as it is required.

4.2.3. Unavailability of gaseous fuel when operating in a dual-fuel mode

Upon detection of an empty gaseous fuel tank, or of a malfunctioning gas supply system according to paragraph 7.3.1.1.:

- (a) Dual-fuel engines of Type 1A shall activate one of the operability restrictions considered in this Paragraph;
- (b) Dual-fuel engines of Types 1B, 2B and 3B shall operate in diesel mode.

4.2.3.1. Unavailability of gaseous fuel – empty gaseous fuel tank

In the case of an empty gaseous fuel tank, an operability restriction or, as appropriate according to paragraph 4.2.3., the diesel mode shall be activated according to paragraph 4.2.2.2. as soon as the engine system has detected that the tank is empty.

When the gas availability in the tank again reaches the level that justified the activation of the empty tank warning system specified in paragraph 4.3.2., the operability restriction may be deactivated, or, when appropriate, the dual-fuel mode may be reactivated.

4.2.3.2. Unavailability of gaseous fuel – malfunctioning gas supply

In the case of a malfunctioning gas supply system according to paragraph 7.3.1.1., an operability restriction or, as appropriate according to paragraph 4.2.3., the diesel mode shall be activated according to paragraph 4.2.2.2. when the OBD system has determined the presence of a malfunction in the gas supply.

As soon as the diagnostic system concludes that the malfunction is no longer present or when the OBD information is erased by a scan tool, the operability restriction may be deactivated or, when appropriate, the dual-fuel mode may be reactivated.

4.2.3.2.1. If the counter specified in paragraph 4.4. that is associated with a malfunctioning gas supply system of a Type 1A dual-fuel engine is not at zero, and is consequently indicating that the monitor has detected a situation when the malfunction may have occurred for a second or subsequent time, the operability restriction shall be activated according to paragraph 4.2.2.2. when the OBD system has determined the presence of a pending malfunction of the gas supply.

³ A vehicle shall be considered as stationary at the latest 1 minute after the vehicle speed has been reduced to zero km/h. The engagement of any device such as a park-brake, a trailer-brake, or a hand-brake shall not be necessary for being stationary.

- 4.3. Dual-fuel indicators
- 4.3.1. Dual-fuel operating mode indicator
- Dual-fuel engines and vehicles shall have a visual indicator indicating to the driver the mode under which the engine operates (dual-fuel mode, diesel mode, or, when applicable, service mode).
- The characteristics and the location of this indicator are left to the decision of the manufacturer and may be part of an already existing visual indication system.
- This indicator may be completed by a message display. The system used for displaying the messages referred to in this point may be the same as the ones used for OBD, correct operation of NO_x control measures, or other maintenance purposes.
- The visual element of the dual-fuel operating mode indicator shall not be the same as the one used for the purposes of OBD (that is, the MI – malfunction indicator), for the purpose of ensuring the correct operation of NO_x control measures, or for other engine maintenance purposes.
- Safety alerts always have display priority over the operating mode indication.
- 4.3.1.1. The driver shall be alerted as soon as an operability restriction requires the service mode to be activated (i.e. before it becomes actually active) Setting the dual-fuel operating mode indicator to service mode for that purpose is permitted. The service mode indication shall in any case remain displayed as long as the service mode is active.
- 4.3.1.2. The dual-fuel mode indicator shall be set for at least one minute on dual-fuel mode or diesel mode as soon as the engine operating mode is changed from diesel to dual-fuel mode or vice-versa. This indication is also required for at least 1 minute at key-on, or at the request of the manufacturer at engine cranking. The indication shall also be given upon the driver's request.
- 4.3.2. Empty gaseous fuel tank warning system (dual-fuel warning system)
- A dual-fuel vehicle shall be equipped with a dual-fuel warning system that alerts the driver that the gaseous fuel tank will soon become empty.
- The dual-fuel warning system shall remain active until the tank is refuelled to a level above which the warning system is activated.
- The dual-fuel warning system may be temporarily interrupted by other warning signals providing important safety-related messages.
- It shall not be possible to turn off the dual-fuel warning system by means of a scan-tool as long as the cause of the warning activation has not been rectified.
- 4.3.2.1. Characteristics of the dual-fuel warning system
- The dual-fuel warning system shall consist of a visual alert system (icon, pictogram, etc...) left to the choice of the manufacturer.
- It may include, at the choice of the manufacturer, an audible component. In that case, the cancelling of that component by the driver is permitted.

The visual element of the dual-fuel warning system shall not be the same as the one used for the OBD system (that is, the MI – malfunction indicator), for the purpose of ensuring the correct operation of NO_x control measures, or for other engine maintenance purposes.

In addition the dual-fuel warning system may display short messages, including messages indicating clearly the remaining distance or time before the activation of the operability restriction.

The system used for displaying the messages referred to in this paragraph may be the same as the one used for displaying additional OBD messages, messages related to correct operation of NO_x control measures, or messages for other maintenance purposes.

A facility to permit the driver to dim the visual alarms provided by the warning system may be provided on vehicles for use by the rescue services or on vehicles designed and constructed for use by the armed services, civil defense, fire services and forces responsible for maintaining public order.

4.4. Malfunctioning gas supply counter

Type 1A dual-fuel engines shall contain a counting system to record the number of hours during which the engine has been operated while the system has detected a malfunctioning gas supply system according to paragraph 7.3.1.1.

4.4.1. The activation and deactivation criteria and mechanisms of the counter dedicated to abnormality of the gaseous fuel consumption shall comply with the specifications of Appendix 2.

4.5. Demonstration of the dual-fuel indicators and operability restriction

As part of the application for type approval under this Regulation, the manufacturer shall demonstrate the operation of dual-fuel indicators and of the operability restriction in accordance with the provisions of Appendix 3.

4.6. [Reserved]

4.7. Requirements to limit Off-Cycle Emissions (OCE) and in-use emissions

4.7.1. GER test at certification

An ESC test-cycle shall be performed immediately after or before having performed the ETC test-cycle where the type of dual-fuel engine has been confirmed.

The fuels used in both tests shall be the same as well as all other test conditions, including the test bench.

The average gas ratio over this ESC test-cycle (GER_{ESC}) is calculated using the weighted average of the consumption of both fuels over this cycle.

4.7.1.1. Type 1 dual-fuel engines

In the case of Type 1 dual-fuel engines, the average gas ratio calculated over this ESC test-cycle (GER_{ESC}) shall not be lower than 90 per cent ($GER_{ESC} \geq 90\%$).

- 4.7.1.2. Type 2 dual-fuel engines
- In the case of Type 2 dual-fuel engines, the absolute difference between the average gas ratio calculated over this ETC test-cycle (GER_{ETC}) and the average gas ratio calculated over this ESC test-cycle (GER_{ESC}) shall not exceed 20 per cent of the GER_{ETC} .
5. Performance requirements
- 5.1. Emission limits applicable to Type 1A and Type 1B dual-fuel engines
- 5.1.1. The emission limits applicable to Type 1A and Type 1B dual-fuel engines operating in dual-fuel mode are those defined for gas engines in rows B2 (Euro V) and C (EEV) of Table 2 of paragraph 5.2.1. of this Regulation.
- 5.1.2. The emission limits applicable to Type 1B dual-fuel engines operating in diesel-mode are those defined for diesel engines in rows B2 and C of tables 1 and 2 of paragraph 5.2.1. of this Regulation.
- 5.2. Emission limits applicable to Type 2B dual-fuel engines
- 5.2.1. Emission limits applicable over the ESC test-cycle
- The emission limits over the ESC test-cycle applicable to Type 2B dual-fuel engines operating in diesel mode are those applicable to Diesel engines over the ESC test-cycle and defined in rows B2 and C of Table 1 of paragraph 5.2.1. of this Regulation.
- 5.2.2. Emission limits applicable over the ETC test-cycle
- 5.2.2.1. Emission limits for CO, NO_x and PM mass
- The CO, NO_x and PM mass emission limits over the ETC test-cycle applicable to Type 2B dual-fuel engines operating in dual-fuel and diesel mode over the ETC test-cycle are defined in rows B2 and C of Table 2 of paragraph 5.2.1. of this Regulation.
- 5.2.2.2. Emission limits for Hydrocarbons
- 5.2.2.2.1. NG dual-fuel engines operating in dual-fuel mode
- The THC, NMHC and CH₄ emission limits over the ETC test-cycle applicable to Type 2B dual-fuel engines operating with Natural Gas in dual-fuel mode are calculated from the NMHC and CH₄ limits applicable to Diesel and gas engines over the ETC test-cycle and defined in rows B2 and C of Table 2 of paragraph 5.2.1. of this Regulation. The calculation procedure is specified in paragraph 5.2.3. of this annex.
- 5.2.2.2.2. LP dual-fuel G engines operating in dual-fuel mode
- The THC emission limits over the ETC test-cycle applicable to Type 2B dual-fuel engines operating with LPG in dual-fuel mode are the THC limits for Diesel engines as considered in paragraph 5.2.2.1. of this Regulation.
- 5.2.2.2.3. Dual-fuel engines operating in diesel mode
- The NMHC emission limits over the ETC test-cycle applicable to Type 2B dual-fuel engines operating in diesel mode are those defined in rows B2 and C of Table 2 of paragraph 5.2.1. of this Regulation.

5.2.3. Calculation procedure to determine the hydrocarbon limits (in g/kWh) applicable to Type 2B dual-fuel engines operating in dual-fuel mode during the ETC test cycle.

The following calculation procedure applies to Type 2B dual-fuel engines tested over the ETC cycle while operating in dual-fuel mode:

Calculate the average gas ratio GER_{ETC} over the ETC test cycle

Calculate a corresponding THC_{GER} in g/kWh using the following formula:

$$THC_{GER} = NMHC_{NG} + (CH4_{NG} * GER_{ETC})$$

Determine the applicable THC limit in g/kWh using the following method:

If $THC_{GER} \leq CH4_{NG}$, then

- (a) THC limit value = THC_{GER} and
- (b) No applicable CH_4 and NMHC limit value

If $THC_{GER} > CH4_{NG}$, then

- (a) No applicable THC limit value; and
- (b) Both the $NMHC_{NG}$ and $CH4_{NG}$ limit values are applicable.

In this procedure,

$NMHC_{NG}$ is the NMHC emission limit over the ETC test-cycle and made applicable to NG engine in rows B2 and C of Table 2 of paragraph 5.2.1 of this Regulation.

$CH4_{NG}$ is the CH_4 emission limit over the ETC test-cycle and applicable to NG engine in rows B2 and C of Table 2 of paragraph 5.2.1. of this Regulation.

Figure 1
Illustration of the HC limits in the case of a dual-fuel engine operating in dual-fuel mode during the ETC cycle (natural gas dual-fuel engines)

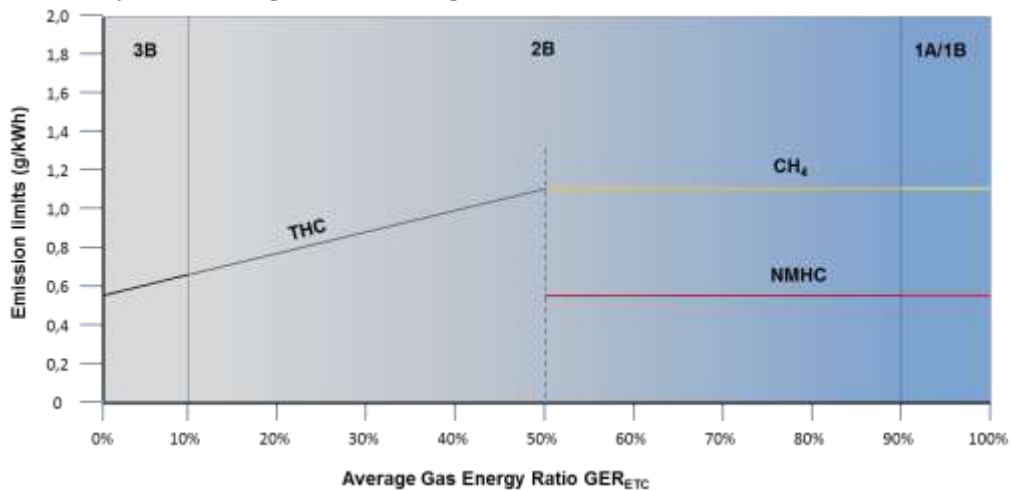

- 5.3. Emission limits applicable to Type 3B dual-fuel engines
- 5.3.1. Emission limits applicable to Type 3B dual-fuel engines operating in dual-fuel mode
- 5.3.1.1. The emissions limits over the ESC test-cycle applicable to Type 3B dual-fuel engines operating in dual-fuel mode are the exhaust emission limits applicable to diesel engines and specified in rows B2 and C of Table 1 of paragraph 5.2.1. of this Regulation.
- 5.3.1.2. The CO, NO_x and PM mass emission limits over the ETC test-cycle applicable to Type 3B dual-fuel engines operating in dual-fuel mode are the exhaust emission limits applicable to diesel engines and specified in rows B2 and C of Table 2 of paragraph 5.2.1. of this Regulation.
- 5.3.1.3. The THC emission limit over the ETC test-cycle applicable to Type 3B dual-fuel engines operating in dual-fuel mode is calculated from the NMHC and CH₄ limits applicable to diesel and gas engines over the ETC test-cycle and defined in rows B2 and C of Table 2 of paragraph 5.2.1. of this Regulation.
- The calculation procedure is the following:
- Calculate the average gas ratio GER_{ETC} over the ETC test cycle;
 - Calculate a corresponding THC_{GER} in g/kWh using the following formula: $THC = NMHC_{NG} + (CH4_{NG} * GER_{ETC})$.
- In this procedure,
- NMHC_{NG} is the NMHC emission limit over the ETC test-cycle and made applicable to NG engine in rows B2 and C of Table 2 of paragraph 5.2.1 of this Regulation;
 - CH_{4NG} is the CH₄ emission limit over the ETC test-cycle and applicable to NG engine in rows B2 and C of Table 2 of paragraph 5.2.1 of this Regulation.
- 5.3.2. Emission limits applicable to Type 3B dual-fuel engines operating in diesel mode
- The emission limits applicable to Type 3B dual-fuel engines operating in diesel mode are those defined for diesel engines in rows B2 and C of Tables 1 and 2 of paragraph 5.2.1. of this Regulation.
6. Demonstration requirements
- 6.1 Laboratory tests

Table 1
Laboratory tests to be performed by a dual-fuel engine

	<i>Type 1A</i>	<i>Type 1B</i>	<i>Type 2B</i>	<i>Type 3B</i>
ETC	NMHC; CH ₄ ; CO; NO _x ; PM	Dual-fuel mode: NMHC; CH ₄ ; CO; NO _x ; PM Diesel mode: NMHC; CO; NO _x ; PM	Dual-fuel mode: THC; NMHC; CH ₄ ; CO; NO _x ; PM Diesel mode: NMHC; CO; NO _x ; PM	Dual-fuel mode: THC; CO; NO _x ; PM Diesel mode: NMHC; CO; NO _x ; PM

	<i>Type 1A</i>	<i>Type 1B</i>	<i>Type 2B</i>	<i>Type 3B</i>
ESC	GER determination only -	Dual-fuel mode: GER determination only- Diesel mode: HC; CO; NO _x ; PM	Dual-fuel mode: GER determination only Diesel mode: HC; CO; NO _x ; PM	Dual-fuel mode: THC; CO; NO _x ; PM Diesel mode: HC; CO; NO _x ; PM

- 6.1.1. When a Type 1B, 2B or 3B dual-fuel engine is developed from an already certified diesel engine, then the engine shall be tested and approved in both dual-fuel and diesel modes.
- 6.1.2. Dual-fuel engines are subject to the requirements of this Regulation regarding NH₃ emissions whether operating in diesel or dual-fuel mode.
- 6.2. Demonstrations in case of installation of a type-approved dual-fuel engine
- This paragraph considers the case where the vehicle manufacturer requests approval of the installation on a vehicle of a dual-fuel engine that is type-approved to the requirements of this annex.
- In this case, and in addition to the general requirements of this annex, a demonstration of the correct installation is required. This demonstration shall be done on the basis of the appropriate element of design, results of verification tests, etc. and address the conformity of the following elements to the requirements of this annex:
- (a) The dual-fuel indicators and warnings as specified in this annex (pictogram, activation schemes, etc.);
 - (b) The fuel storage system.
- Correct indicator illumination and warning system activation will be checked. But any check shall not force dismantling the engine system (e.g. an electric disconnection may be selected).
- 6.3. Additional demonstration requirements in case of a Type2 engine
- The manufacturer shall present the Type Approval Authority with evidence showing that the GER_{ETC} span of all members of the dual-fuel engine family remains within the percentage specified in paragraph 3.1.1. (for example results of previous tests).
- 6.4. Additional demonstration requirements in case of a universal fuel range type approval
- On request of the manufacturer and with approval of the Type Approval Authority, a maximum of two times the last 10 minutes of the WHTC may be added to the adaptation run between the demonstration tests.
- 6.5. Requirements for demonstrating the durability of a dual-fuel engine
- Provisions of Annex 7 shall apply

7. OBD requirements
- 7.1. General OBD requirements
- All dual-fuel engines and vehicles, independent of whether the engine operates in dual-fuel or in diesel mode, shall comply with the OBD Stage 2 requirements specified in Annex 9A to this regulation and applicable to diesel engines.
- The exemptions to these rules, including the rules concerning the OBD deficiencies and the monitoring exemptions set out in paragraph 3.3.3. of Annex 9A to this Regulation shall apply.
- 7.2. Additional general OBD requirements in case of Type B dual-fuel engines
- In the case of Type 1B, Type 2B, and Type 3B dual-fuel engines, it is allowed to have 2 separate OBD systems on-board the vehicle, one operating in dual-fuel mode, the other operating in diesel mode. It shall be possible to retrieve OBD information separately from each of these systems according to the requirements of Annex 9A to this Regulation.
- 7.3. Additional OBD requirements for dual-fuel mode
- 7.3.1. Monitoring requirements regarding the dual-fuel engine system
- 7.3.1.1. Monitoring requirements regarding the gas injection system
- The gas injection system electronics, fuel quantity and timing actuator(s) shall be monitored for circuit continuity (i.e. open circuit or short circuit) and total functional failure when the engine operates in dual-fuel mode.
- 7.3.2. Monitoring requirements regarding the catalysts specific to dual-fuel mode
- In the case of a catalyst that is solely used in dual-fuel mode, the OBD system shall monitor for the complete removal and for major functional failure of that catalyst when the engine operates in dual-fuel mode.
- Notes:*
- (a) The replacement of the catalyst system by a bogus system (intentional major functional failure) shall be considered as a major functional failure;
- (b) All dual-fuel specific catalyst shall be considered where fitted in a separate housing, that may or may not be part of a deNOx system or particulate filter.
- 7.4. Switch to Diesel mode
- In the case when the OBD systems of Type 1B, Type 2B, and Type 3B dual-fuel engines concludes that a malfunction has occurred when running in dual-fuel mode, it is permitted to automatically switch to diesel mode.
- 7.4.1. When the OBD systems of Type 1B, Type 2B, and Type 3B dual-fuel engines determines that a malfunction of the gas injection system or of a catalyst specific to dual-fuel mode has occurred when running in dual-fuel mode, it is permitted to automatically switch to diesel mode and to switch off the malfunction indicator.

In that case, however, the status of the Diagnostic Trouble Code (DTC) associated to the concerned malfunction and of the associated counters shall be kept frozen until the next time the engine switches back to the dual-fuel mode.

8. Requirements to ensure the correct operation of NO_x control measures
 - 8.1. Paragraph 5.5. (on correct operation of NO_x control measures) to this Regulation shall apply to dual-fuel engines and vehicles, whether operating in dual-fuel mode or, in the case of Types 1B, 2B, and 3B dual-fuel engines, in diesel mode.
 - 8.2. When a service mode is available it is allowed to switch to that mode instead of applying the torque reduction considered in paragraph 5.5. The engine shall then stay in service mode until the issue causing the torque reduction is fixed.
 - 8.3. Dual-fuel engines of Types 1B, 2B, and 3B
 - 8.3.1. In the case of Type 1B, Type 2B, and Type 3B dual-fuel engines, the torque reduction defined in paragraph 5.5.5.3. shall be calculated on the basis of the lowest of the maximum torques obtained in diesel mode and in dual-fuel mode.
 - 8.3.2. In the case of Type 1B, Type 2B, and Type 3B dual-fuel engines operating in dual-fuel mode, if a torque reduction is required according to paragraph 5.5. the system may either
 - (a) Apply the torque reduction required in paragraph 8.3.1.; or
 - (b) Automatically switch to diesel mode or service mode and stay in that mode until the issue causing inducement is fixed.
 - 8.3.3. Switching to diesel mode or service mode and staying in that mode until the issue causing inducement is fixed is mandatory in the case when, in dual-fuel mode, it is not possible to reduce the torque to the level required in paragraph 8.3.1.
9. Conformity of in-service engines or vehicles/engines

The conformity of in-service dual-fuel engines and vehicles shall be performed according to the requirements specified in Annex 8, with the exceptions set out in paragraphs 9.1. to 9.3.

 - 9.1. The emission tests shall be performed in dual-fuel mode and, in case of Type 1B, 2B, and 3B also in diesel mode.
 - 9.2. The emission limits considered when evaluating the conformity are those set out in paragraph 5 ("Performance requirements") of this annex.
 - 9.3. Additional requirements for Type 1B, Type 2B and Type 3B dual-fuel engines
 - 9.3.1. The emission test in diesel mode shall be performed on the same engine immediately after, or before, the emission test is performed in dual-fuel mode.
 - 9.3.2. Paragraph 5.3. of Annex 8 shall not apply. The confirmatory test may instead be regarded as non-satisfactory when, from tests of two or more engines representing the same engine family, for any regulated pollutant component, the limit value as specified in this annex is exceeded significantly either in dual-fuel mode or in diesel mode.

10. Additional test procedures
- 10.1. Additional emission test procedure requirements for dual-fuel engines
- 10.1.1. Dual-fuel engines shall comply with the requirements of Appendix 4 in addition to the requirements of this Regulation (including Annex 4B) when performing an emission test.
11. Documentation requirements
- 11.1. Documentation for installing in a vehicle a type approved dual-fuel engine
- The manufacturer of a dual-fuel engine type-approved as separate technical unit shall include in the installation documents of its engine system the appropriate requirements that will ensure that the vehicle, when used on the road or elsewhere as appropriate, will comply with the requirements of this annex. This documentation shall include but is not limited to:
- (a) The detailed technical requirements, including the provisions ensuring the compatibility with the OBD system of the engine system;
- (b) The verification procedure to be completed.
- The existence and the adequacy of such installation requirements may be checked during the approval process of the engine system.
- 11.1.1. In the case when the vehicle manufacturer who applies for approval of the installation of the engine system on the vehicle is the same manufacturer who received the type approval of the dual-fuel engine as a separate technical unit, the documentation specified in paragraph 11.1. is not required.
12. Appendices
- Appendix 1 Types of dual-fuel engines and vehicles - illustration of the definitions and requirements
- Appendix 2 Activation and deactivation mechanisms of the counter(s), warning system, operability restriction, service mode in case of dual-fuel engines and vehicles - Description and illustrations
- Appendix 3 Dual-fuel indicators, warning system, operability restriction - Demonstration requirements
- Appendix 4 Additional emission test procedure requirements for dual-fuel engines
- Appendix 5 Determination of molar component ratios and u_{gas} values for dual-fuel engines

Annex 11 - Appendix 1

Types of dual-fuel engines and vehicles - illustration of the definitions and requirements

	GER_{ETC}^1	Idle on diesel	Warm-up on diesel	Operation on diesel solely	Service-mode	Comments
Type 1A	$GER_{ETC} \geq 90\%$	NOT Allowed	Allowed	NOT Allowed	Allowed	
Type 1B	$GER_{ETC} \geq 90\%$	Allowed only on Diesel mode	Allowed only on Diesel mode	Allowed only on Diesel mode	Allowed ²	
Type 2A	NEITHER DEFINED NOR ALLOWED					
Type 2B	$10\% < GER_{ETC} < 90\%$	Allowed	Allowed only on Diesel mode	Allowed only on Diesel mode	Allowed ²	$GER_{ETC} \geq 90\%$ allowed ³
Type 3A	NEITHER DEFINED NOR ALLOWED					
Type 3B	$GER_{ETC} \leq 10\%$	Allowed	Allowed only on Diesel mode	Allowed only on Diesel mode	Allowed ²	

¹ His average Gas Energy Ratio GER_{ETC} is calculated over the ETC test-cycle.

² Automatic switch-over to diesel mode allowed.

³ Idling exclusively on diesel fuel in dual-fuel mode.

Annex 11 – Appendix 2

Activation and deactivation mechanisms of the counter(s), warning system, operability restriction, service mode in case of dual-fuel engines and vehicles - Description and illustrations

- A.2.1. Description of the counter mechanism
 - A.2.1.1. General
 - A.2.1.1.1. In the case of a Type 1A dual-fuel engine, in order to comply with the requirements of this annex, the system shall contain a counter to record the number of hours during which the engine has been operated while the system has detected a malfunctioning gas supply.
 - A.2.1.1.2. This counter shall be capable of counting up to 30 minutes operating time. The counter intervals shall be no longer than 3 minutes. When reaching its maximum value permitted by the system, it shall hold that value unless the conditions allowing the counter to be reset to zero are met.
 - A.2.1.2. Principle of the counter mechanism
 - A.2.1.2.1. The counters shall operate as follows:
 - A.2.1.2.1.1. If starting from zero, the counter shall begin counting as soon as a malfunctioning gas supply is detected according to paragraph 7.3.1.1. of this annex and the corresponding diagnostic trouble code (DTC) has the status confirmed and active.
 - A.2.1.2.1.2. The counter shall halt and hold its current value if a single monitoring event occurs and the malfunction that originally activated the counter is no longer detected or if the failure has been erased by a scan tool or a maintenance tool.
 - A.2.1.2.1.2.1. The counter shall also halt and hold its current value when the service mode becomes active.
 - A.2.1.2.1.3. Once frozen, the counter shall be reset to zero and restart counting if a malfunction relevant to that counter is detected and the service mode activated.
 - A.2.1.2.1.3.1. Once frozen, the counter shall also be reset to zero when the monitors relevant to that counter have run at least once to completion of their monitoring cycle without having detected a malfunction and no malfunction relevant to that counter has been detected during 36 engine operating hours since the counter was last held.
 - A.2.1.3. Illustration of the counter mechanism

Figures A2.1.1 to A2.1.3 give via three use-cases an illustration of the counter mechanism.

Illustration of the gas supply counter mechanism (Type 1A dual-fuel engine (HDDF)) - use-case 1

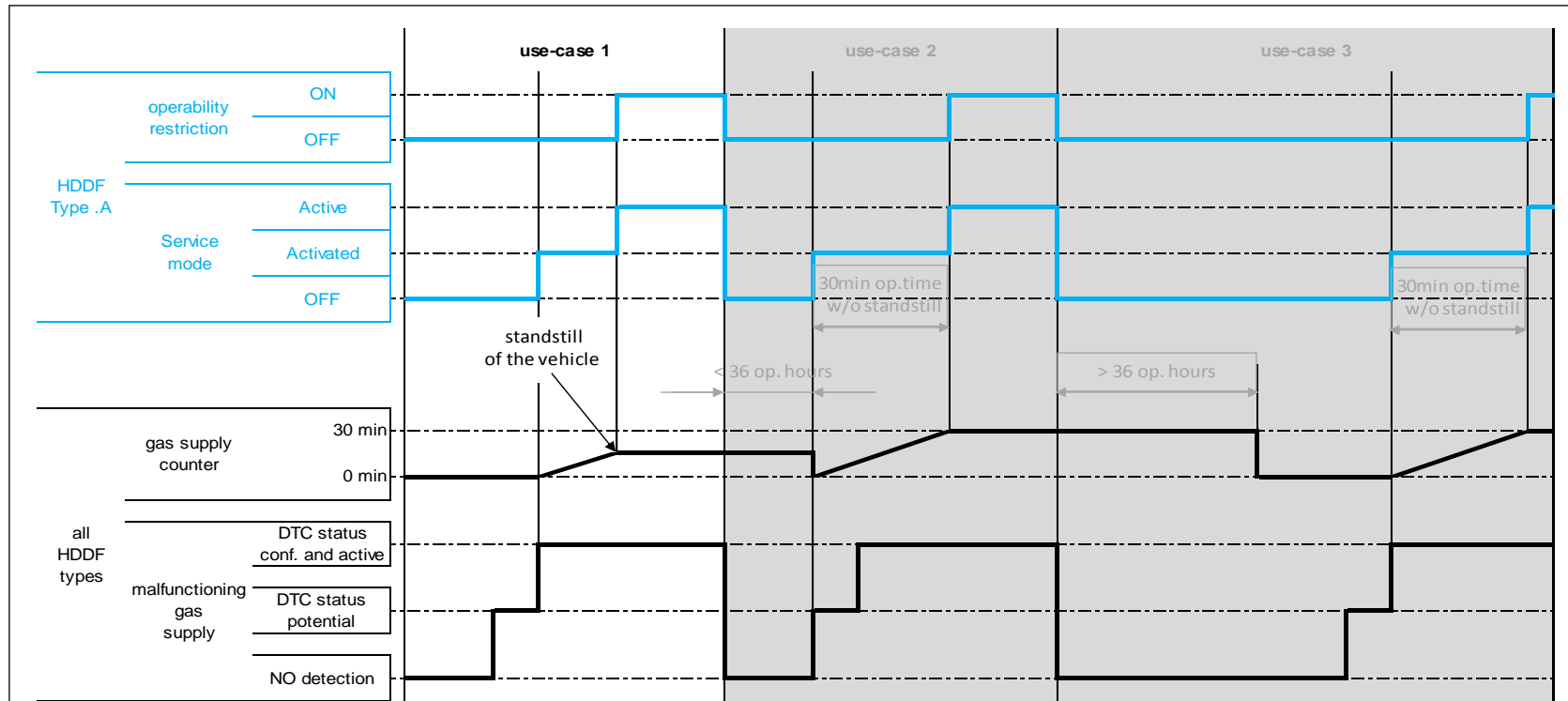

A malfunction of the gas supply is detected for the very first time.

The service mode is activated and the counter starts counting once the DTC gets the "confirmed and active" status (2nd detection).

The vehicle encounters a stand-still situation before reaching 30 minutes operating time after the service mode is activated.

The service mode becomes active and the vehicle speed is limited to 20 km/h (see paragraph 4.2.2.1. of this annex).

The counter freezes at its present value.

Figure A2.1.2

Illustration of the gas supply counter mechanism (Type 1A dual-fuel engine (HDDF)) - use-case 2

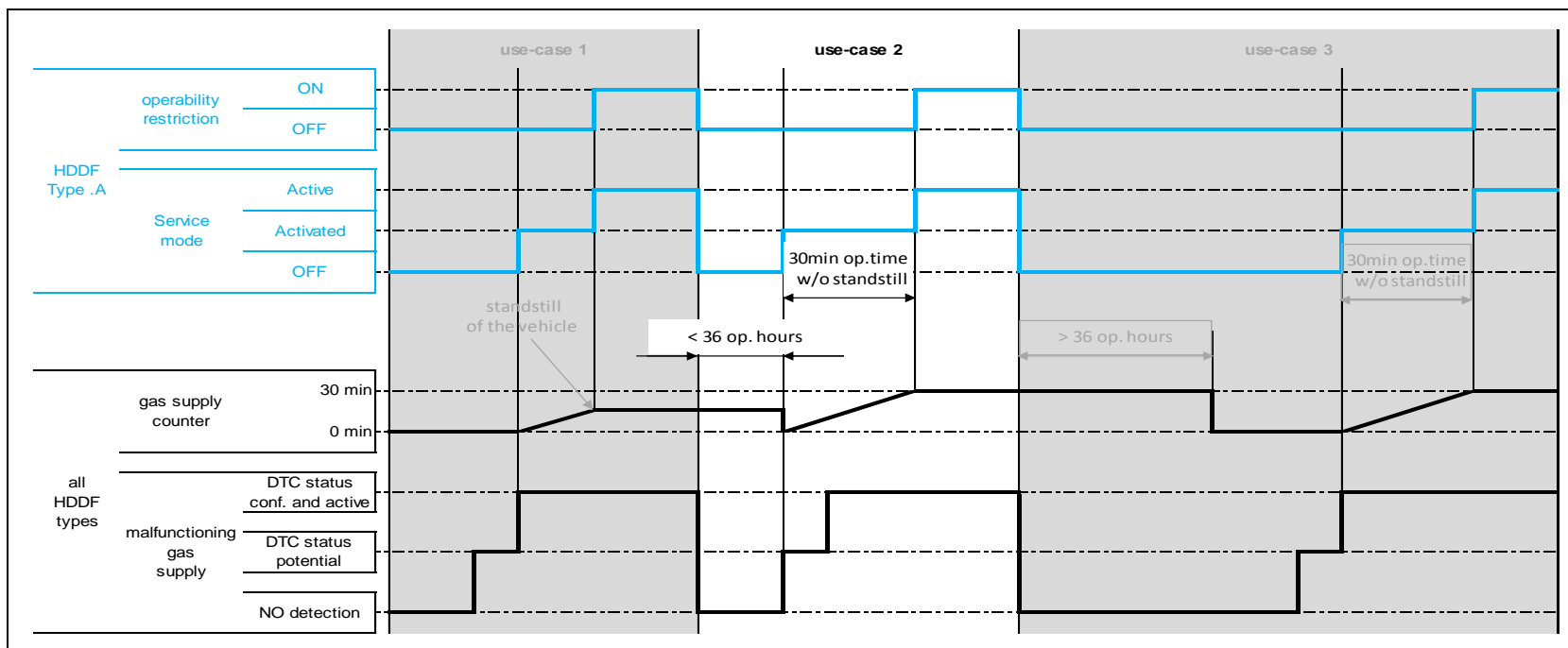

A malfunction of the gas supply is detected while the gas supply malfunction counter is not at zero (in this use-case it indicates the value it reached in use-case 1 when the vehicle became standstill).

The service mode is activated and the counter restarts counting from zero as soon as the DTC gets the "potential" status (1st detection: see paragraph 4.2.3.2.1. of this annex).

After 30 minutes of operation without a standstill situation, the service mode becomes active and the vehicle speed is limited to 20 km/h (see paragraph 4.2.2.1. of this annex).

The counter freezes at a value of 30 minutes operating time.

Figure A2.1.3

Illustration of the gas supply counter mechanism (Type 1A dual-fuel engine (HDDF)) - use-case 3

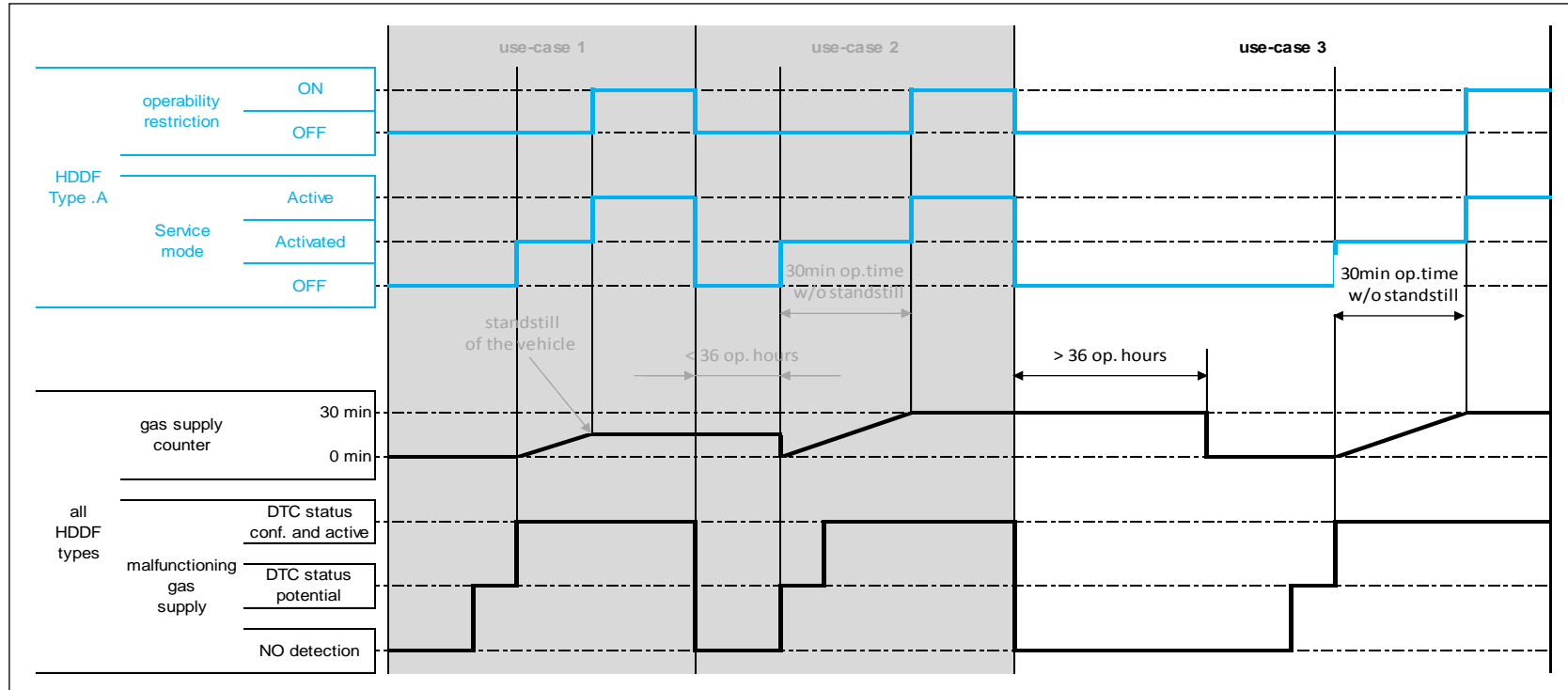

After 36 operating hours without detection of a malfunction of the gas supply, the counter is reset to zero (see paragraph A.2.1.2.3.2.1.).

A malfunction of the gas supply is again detected while the gas supply malfunction counter is at zero (1st detection).

The service mode is activated and the counter starts counting once the DTC gets the ""confirmed and active"" status (2nd detection).

After 30 minutes of operation without a standstill situation, the service mode becomes active and the vehicle speed is limited to 20 km/h (see paragraph 4.2.2.1. of this annex).

The counter freezes at a value of 30 minutes operating time.

A.2.2. Illustration of the other activation and deactivation mechanisms

A.2.2.1. Empty gas tank

Figure A2.2 gives an illustration of the events occurring in the case of a dual-fuel vehicle when a gas tank becomes empty through one typical use-case.

Figure A2.2

Illustration of the events occurring in case of an empty gas tank of a dual-fuel engine/vehicle (HDDF)

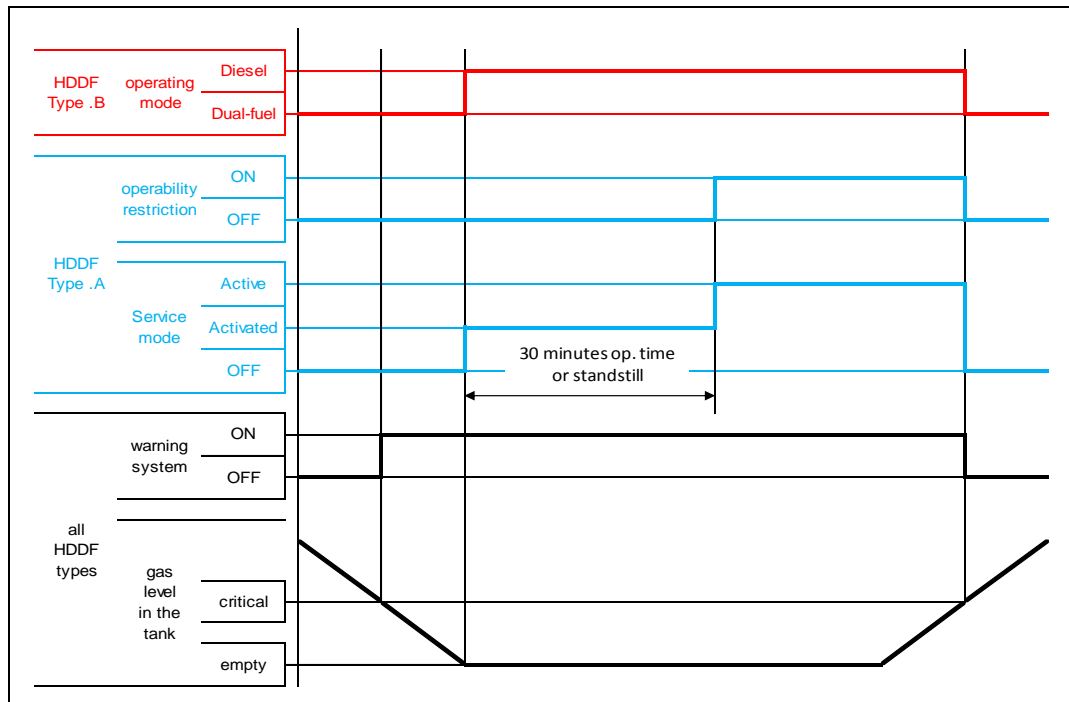

In that use case:

- (a) The warning system specified in paragraph 4.3.2. of this annex becomes active when the level of gas reaches the critical level defined by the manufacturer;
- (b) The service mode is activated (in the case of a Type 1A dual-fuel engine with service mode as operating restriction) or the engine switches to diesel mode (in the case of a Type B dual-fuel engine).

In the case of a Type 1A dual-fuel engine, the service mode becomes active and the vehicle speed is limited to 20 km/h after the next time the vehicle is stationary¹ or after 30 minutes operating time without standstill (see paragraph 4.2.2.1. of this annex).

The gas tank is refilled.

¹ A vehicle shall be considered as stationary at the latest 1 minute after the vehicle speed has been reduced to zero km/h. The engagement of any device such as a park-brake, a trailer-brake, or a hand-brake shall not be necessary for being stationary.

The vehicle operates again in dual-fuel mode as soon as the tank is refilled above the critical level.

A.2.2.2. Malfunctioning gas supply

Figure A2.3 gives via one typical use-case an illustration of the events occurring in the case of a malfunction of the gas supply system. This illustration should be understood as complementary to that given in paragraph A.2.1 and dealing with the counter mechanism.

Figure A2.3

Illustration of the events occurring in case of a malfunctioning gas supply system of a dual-fuel engine/vehicle (HDDF)

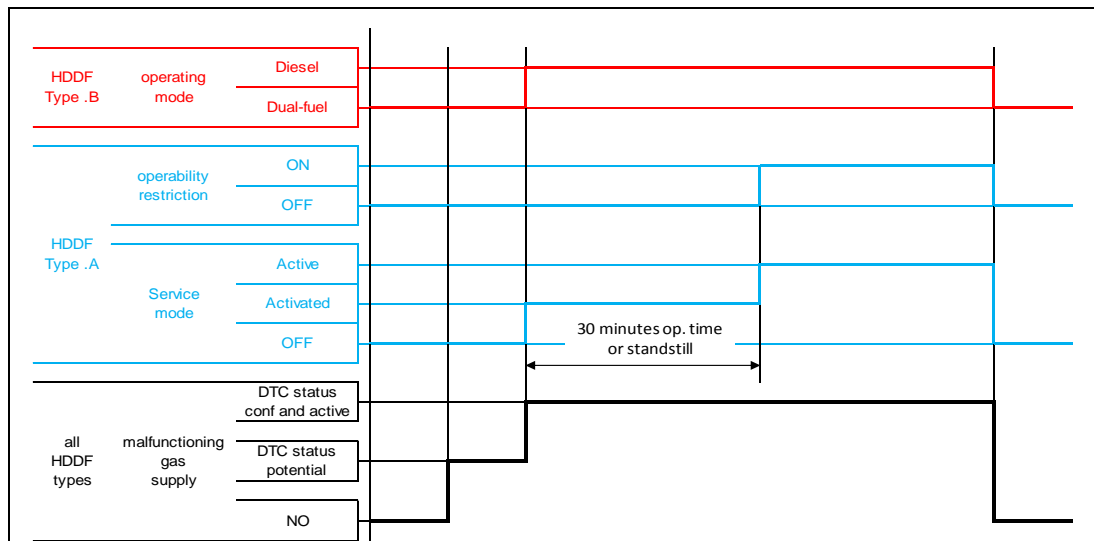

In that use case:

- (a) The failure of the gas supply system occurs for the very first time. The DTC gets the potential status (1st detection);
- (b) The service mode is activated (in the case of a Type 1A dual-fuel engines with a service mode as operability restriction) or the engine switches to diesel mode (in the case of a Type B dual-fuel engine) as soon as the DTC gets the "confirmed and active" status (2nd detection).

In the case of a Type 1A dual-fuel-engine, the service mode becomes active and the vehicle speed is limited to 20 km/h after the next time the vehicle is stationary² or after 30 minutes operating time without standstill (see paragraph 4.2.2.1. of this annex).

The vehicle operates again in dual-fuel mode as soon as the failure is repaired.

² A vehicle shall be considered as stationary at the latest 1 minute after the vehicle speed has been reduced to zero km/h. The engagement of any device such as a park-brake, a trailer-brake, or a hand-brake shall not be necessary for being stationary.

Annex 11 – Appendix 3

Dual-fuel indicators, warning system, operability restriction - Demonstration requirements

A.3.1. Dual-fuel indicators

A.3.1.1. Dual-fuel mode indicator

In the case where a dual-fuel engine is type approved as a separate technical unit, the ability of the engine system to command the activation of the dual-fuel mode indicator when operating in dual-fuel mode shall be demonstrated at type approval.

In the case where a dual-fuel vehicle is type approved in respect of its engine, the activation of the dual-fuel mode indicator when operating in dual-fuel mode shall be demonstrated at type approval.

Note: Demonstration requirements related to the dual-fuel mode indicator in the case of the installation of a type-approved dual-fuel engine in a vehicle are specified in paragraph 6.2. of this annex.

A.3.1.2. Diesel mode indicator

In the case where a dual-fuel engine of Type 1B, Type 2B, or Type 3B is type approved as a separate technical unit, the ability of the engine system to command the activation of the diesel mode indicator when operating in diesel mode shall be demonstrated at type approval.

In the case where a dual-fuel vehicle of Type 1B, Type 2B, or Type 3B is type approved in respect of its engine, the activation of the diesel mode indicator when operating in diesel mode shall be demonstrated at type approval.

Note: Demonstration requirements related to the diesel mode indicator in the case of the installation of a type approved Type 1B, Type 2B, or Type 3B dual-fuel engine in a vehicle are specified in paragraph 6.2. of this annex.

A.3.1.3. Service mode indicator

In the case where a dual-fuel engine is type approved as a separate technical unit, the ability of the engine system to command the activation of the service mode indicator when operating in service mode shall be demonstrated at type approval.

In the case where a dual-fuel vehicle is type approved with regard to its emissions, the activation of the service mode indicator when operating in service mode shall be demonstrated at type approval.

Note: Demonstration requirements related to the service mode indicator in the case of the installation of a type approved dual-fuel engine in a vehicle are specified in paragraph 6.2. of this annex.

- A.3.1.3.1. When so-equipped it is sufficient to perform the demonstration related to the service mode indicator by activating a service mode activation switch and to present the Type Approval Authority with evidence showing that the activation occurs when the service mode is commanded by the engine system itself (for example, through algorithms, simulations, result of in-house tests, etc.).

A.3.2. Dual-fuel warning system

In the case where a dual-fuel engine is type approved as a separate technical unit, the ability of the engine system to command the activation of the dual-fuel warning system in the case that the amount of gas in the tank is below the warning level, shall be demonstrated at type approval.

In the case where a dual-fuel vehicle is type-approved in respect of its engine the activation of the dual-fuel warning system in the case that the amount of gas in the tank is below the warning level, shall be demonstrated at type approval. For that purpose, at the request of the manufacturer and with the approval of the Type Approval Authority, the actual amount of gas may be simulated.

Note: Demonstration requirements related to the dual-fuel warning system in the case of the installation of a type-approved dual-fuel engine in a vehicle are specified in paragraph 6.2. of this annex.

A.3.3. Unavailability of gaseous fuel when operating in a dual-fuel mode

A.3.3.1. Operability restriction

In the case where a Type 1A dual-fuel engine is type approved as a separate technical unit, the ability of the engine system to command the activation of the operability restriction upon detection of an empty gaseous fuel tank, of a malfunctioning gas supply system in dual-fuel shall be demonstrated at type approval.

In the case where a Type 1A dual-fuel vehicle is type approved in respect of its engine, the activation of the operability restriction upon detection of an empty gaseous fuel tank and, of a malfunctioning gas supply system in dual-fuel mode shall be demonstrated at type approval.

Note: Demonstration requirements related to the operability restriction in the case of the installation of a type-approved Type 1A dual-fuel engine in a vehicle are specified in paragraph 6.2. of this annex.

A.3.3.2. Switch to diesel mode

In the case where a Type 1B, 2B, or 3B dual-fuel engine is type approved as a separate technical unit, the ability of the engine system to switch to diesel mode upon detection of an empty gaseous fuel tank and of a malfunctioning gas supply system in dual-fuel shall be demonstrated at type approval.

In the case where a Type 1B, 2B, or 3B dual-fuel vehicle is type approved in respect of its engine, the switch to diesel mode upon detection of an empty gaseous fuel tank and of a malfunctioning gas supply system in dual-fuel mode shall be demonstrated at type approval.

A.3.3.3. The malfunctioning of the gas supply may be simulated at the request of the manufacturer and with the approval of the Type Approval Authority.

A.3.3.4. It is sufficient to perform the demonstration in a typical use-case selected with the agreement of the Type Approval Authority and to present that authority with evidence showing that the operability restriction occurs in the other possible use-cases (for example, through algorithms, simulations, result of in-house tests, etc.

Annex 11 – Appendix 4

Additional emission test procedure requirements for dual-fuel engines

A.4.1. General

This appendix defines the additional requirements and exceptions to Annexes 4A and 4B of this Regulation to enable emission testing of dual-fuel engines.

Emission testing of a dual-fuel engine is complicated by the fact that the fuel used by the engine can vary between pure diesel fuel and a combination of mainly gaseous fuel with only a small amount of diesel fuel as an ignition source. The ratio between the fuels used by a dual-fuel engine can also change dynamically depending of the operating condition of the engine. As a result special precautions and restrictions are necessary to enable emission testing of these engines.

A.4.2. Test conditions (Annex 4B, paragraph 6.)

A.4.2.1. Laboratory test conditions (Annex 4A, paragraph 2.1. or Annex 4B, paragraph 6.1.)

The parameter f_a for dual-fuel engines shall be determined with formula (a)(2) in paragraph 6.1. of Annex 4B to this regulation.

A.4.3. Test procedures (annex 4A, paragraph 1. and Annex 4B, paragraph 7.)

A.4.3.1. Measurement procedures (Annex 4B, paragraph 7.1.3.)

The recommended measurement procedure for dual-fuel engines is procedure (b) listed in paragraph 7.1.3. of Annex 4B (CVS system).

This measurement procedure ensures that the variation of the fuel composition during the test will only influence the hydrocarbon measurement results. This shall be compensated via one of the methods described in paragraph A.4.4.4.

Other measurement methods such as method (a) listed in paragraph 7.1.3. of Annex 4B (raw gaseous/partial flow measurement) can be used with some precautions regarding exhaust mass flow determination and calculation methods. Fixed values for fuel parameters and u_{gas} -values shall be applied as described in Appendix 5.

A.4.4. Emission calculation (Annex 4B, paragraph 8.)

The emissions calculation on a molar basis, in accordance with Annex 7 of gtr No. 11 concerning the exhaust emission test protocol for Non-Road Mobile Machinery (NRMM), is not permitted.

A.4.4.1. Dry/wet correction (Annex 4A, Appendix 1, paragraph 5.2. and Annex 4B, paragraph 8.1.)

A.4.4.1.1. Raw exhaust gas (Annex 4B, paragraph 8.1.1.)

Equations 15 and 17 in Annex 4B, paragraph 8.1.1. shall be used to calculate the dry/wet correction.

The fuel specific parameters shall be determined according to paragraphs A.5.2. and A.5.3. of Appendix 5.

A.4.4.1.2. Diluted exhaust gas (Annex 4B, paragraph 8.1.2.)

Equations 19 and 20 in Annex 4B, paragraph 8.1.2. shall be used to calculate the wet/dry correction.

The molar hydrogen ratio α of the combination of the two fuels shall be used for the dry/wet correction. This molar hydrogen ratio shall be calculated from the fuel consumption measurement values of both fuels according to paragraph A.5.4. of Appendix 5.

A.4.4.2. NO_x correction for humidity (Annex 4B, paragraph 8.2.)

The NO_x humidity correction for compression ignition engines as specified in paragraph 8.2.1. of Annex 4B shall be used to determine the NO_x humidity correction for dual-fuel engines.

$$k_{h,D} = \frac{15,698 \times H_a}{1\,000} + 0,832 \quad (\text{A4.1})$$

Where:

H_a is the intake air humidity, g water per kg dry air

A.4.4.3. Partial flow dilution (PFS) and raw gaseous measurement (Annex 4B, paragraph 8.4.)

A.4.4.3.1. Determination of exhaust gas mass flow (Annex 4A, Appendix 2, paragraph 4.2. and Annex 4B, paragraph 8.4.1.)

The exhaust mass flow shall be determined according to the direct measurement method as described in paragraph 8.4.1.3. of Annex 4B.

Alternatively the airflow and air to fuel ratio measurement method according to paragraph 4.2.5. (equations 30, 31 and 32 of Annex 4B) may be used only if α , γ , δ and ε values are determined according to paragraph A.5.2. and A.5.3. of Appendix 5. The use of a zirconia-type sensor to determine the air fuel ratio is not allowed.

A.4.4.3.2. Determination of the gaseous components (Annex 4B, paragraph 8.4.2.)

The calculations shall be performed according to Annex 4B, paragraph 8. but the u_{gas} -values and molar ratios as described in paragraph A.5.2. and A.5.3. of Appendix 5 shall be used.

A.4.4.3.3. Particulate determination (Annex 4B, paragraph 8.4.3.)

For the determination of particulate emissions with the partial dilution measurement method the calculation shall be performed according to Annex 4B, paragraph 8.4.3.2.

For controlling the dilution ratio one of the following two methods may be used:

- (a) The direct mass flow measurement as described in paragraph 8.4.1.3.;

- (b) The airflow and air to fuel ratio measurement method according to paragraph 8.4.1.6. (equations 30, 31 and 32) may only be used when this is combined with the look ahead method described in paragraph 8.4.1.2. and if α , γ , δ and ε values are determined according to paragraphs A.5.2. and A.5.3. of Appendix 5.

The quality check according to paragraph 9.4.6.1. shall be performed for each measurement.

A.4.4.3.4. Additional requirements regarding the exhaust gas mass flow meter

The flow meter referred to in paragraphs A.4.4.3.1. and A.4.4.3.3. shall not be sensitive to the changes in exhaust gas composition and density. The small errors of e.g. pitot tube or orifice-type of measurement (equivalent with the square root of the exhaust density) may be neglected.

A.4.4.4. Full flow dilution measurement (CVS) (Annex 4B, paragraph 8.5.)

The possible variation of the fuel composition will only influence the hydrocarbons measurement results calculation. For all other components the appropriate equations from paragraph 8.5.2. of Annex 4B shall be used.

The exact equations shall be applied for the calculation of the hydrocarbon emissions using the molar component ratios determined from the fuel consumption measurements of both fuels according to paragraph A. 5.4. of Appendix 5.

A.4.4.4.1. Determination of the background corrected concentrations (Annex 4B, paragraph 8.5.2.3.2.)

To determine the stoichiometric factor, the molar hydrogen ratio α of the fuel shall be calculated as the average molar hydrogen ratio of the fuel mix during the test according to paragraph A.5.4. of Appendix 5.

Alternatively the F_s value of the gaseous fuel may be used in equation 59 or 60 of Annex 4B.

A.4.5. Equipment specification and verification (Annex 4B, paragraph 9.)

A.4.5.1. Oxygen interference check gases (Annex 4B, paragraph 9.3.3.4.)

The oxygen concentrations required for dual-fuel engines are equal to those required for compression ignition engines listed in table 8 in paragraph 9.3.3.4. of Annex 4B.

A.4.5.2. Oxygen interference check (Annex 4B, paragraph 9.3.7.3.)

Instruments used to measure dual-fuel engines shall be checked using the same procedures as those used to measure compression ignition engines. The 21 per cent oxygen blend shall be used under subparagraph (b) in paragraph 9.3.7.3. of Annex 4B.

A.4.5.3. Water quench check (Annex 4A, Appendix 5, paragraph 1.9.2.2. and Annex 4B, paragraph 9.3.9.2.2.)

The water quench check applies to wet NO_x concentration measurements only. For dual-fuel engines fuelled with natural gas this check should be performed with an assumed H/C ratio of 4 (Methane). In that case $H_m = 2 \times A$. For dual-fuel engines fuelled with LPG this check should be performed with an assumed H/C ratio of 2.525. In that case $H_m = 1.25 \times A$.

Annex 11 – Appendix 5

Determination of molar component ratios and u_{gas} values for dual-fuel engines

A.5.1. General

This appendix defines the determination of molar component ratios and u_{gas} values for the dry-wet factor and emissions calculations for emission testing of dual-fuel engines.

A.5.2. Operation in dual-fuel mode

A.5.2.1. For Type 1A or 1B dual-fuel engines operating in dual-fuel mode the molar component ratios and the u_{gas} values of the gaseous fuel shall be used.

A.5.2.2. For Type 2A or 2B dual-fuel engines operating in dual-fuel mode the molar component ratios and the u_{gas} values from tables A6.1 and A6.2 shall be used.

Table A6.1

Molar component ratios for a mixture of 50 per cent gaseous fuel and 50 per cent diesel fuel (mass per cent)

Gaseous Fuel	α	γ	δ	ε
CH ₄	2.8681	0	0	0.0040
G _R	2.7676	0	0	0.0040
G ₂₃	2.7986	0	0.0703	0.0043
G ₂₅	2.7377	0	0.1319	0.0045
Propane	2.2633	0	0	0.0039
Butane	2.1837	0	0	0.0038
LPG	2.1957	0	0	0.0038
LPG Fuel A	2.1740	0	0	0.0038
LPG Fuel B	2.2402	0	0	0.0039

Table A6.2

Raw exhaust gas u_{gas} values and component densities for a mixture of 50 per cent gaseous fuel and 50 per cent diesel fuel (mass per cent)

Gaseous fuel	ρ_e	Gas					
		NO_x	CO	HC	CO_2	O_2	CH_4
		$\rho_{gas} [kg/m^3]$					
		2.053	1.250	^a	1.9636	1.4277	0.716
u_{gas}^b							
CNG/LNG ^c	1.2786	0.001606	0.000978	0.000528 ^d	0.001536	0.001117	0.000560
Propane	1.2869	0.001596	0.000972	0.000510	0.001527	0.001110	0.000556
Butane	1.2883	0.001594	0.000971	0.000503	0.001525	0.001109	0.000556
LPG ^e	1.2881	0.001594	0.000971	0.000506	0.001525	0.001109	0.000556

a Depending on fuel

b At $\lambda = 2$, dry air, 273 K, 101.3 kPa

c u accurate within 0.2 % for mass composition of: C = 58 - 76 %; H = 19 - 25 %; N = 0 - 14 % (CH₄, G₂₀, G_R, G₂₃ and G₂₅)

d NMHC on the basis of CH_{2.93} (for total HC the u_{gas} coefficient of CH₄ shall be used)

e u accurate within 0.2 % for mass composition of: C3 = 27 - 90 %; C4 = 10 - 73 % (LPG Fuels A and B)

- A.5.2.3. For Type 3B dual-fuel engines operating in dual-fuel mode the molar component ratios and the u_{gas} values of diesel fuel shall be used.
- A.5.2.4. For the calculation of the hydrocarbon emissions of all types of dual-fuel engines operating in dual-fuel mode, the following shall apply:
- For the calculation of the THC emissions, the u_{gas} value of the gaseous fuel shall be used.
 - For the calculation of the NMHC emissions, the u_{gas} value on the basis of $CH_{2.93}$ shall be used.
 - For the calculation of the CH_4 emissions, the u_{gas} value of CH_4 shall be used.
- A.5.3. Operation in diesel mode
For Type 1B, 2B or 3B dual-fuel engines operating in diesel mode, the molar component ratios and the u_{gas} values of diesel fuel shall be used.
- A.5.4. Determination of the molar component ratios when the fuel mix is known
- A.5.4.1. Calculation of the fuel mixture components

$$w_{ALF} = \frac{w_{ALF1} \times q_{mf1} + w_{ALF2} \times q_{mf2}}{q_{mf1} + q_{mf2}} \quad (A6.1)$$

$$w_{BET} = \frac{w_{BET1} \times q_{mf1} + w_{BET2} \times q_{mf2}}{q_{mf1} + q_{mf2}} \quad (A6.2)$$

$$w_{GAM} = \frac{w_{GAM1} \times q_{mf1} + w_{GAM2} \times q_{mf2}}{q_{mf1} + q_{mf2}} \quad (A6.3)$$

$$w_{DEL} = \frac{w_{DEL1} \times q_{mf1} + w_{DEL2} \times q_{mf2}}{q_{mf1} + q_{mf2}} \quad (A6.4)$$

$$w_{EPS} = \frac{w_{EPS1} \times q_{mf1} + w_{EPS2} \times q_{mf2}}{q_{mf1} + q_{mf2}} \quad (A6.5)$$

Where:

q_{mf1}	fuel mass flow rate of fuel1, kg/s
q_{mf2}	fuel mass flow rate of fuel2, kg/s
w_{ALF}	hydrogen content of fuel, per cent mass
w_{BET}	carbon content of fuel, per cent mass
w_{GAM}	sulphur content of fuel, per cent mass
w_{DEL}	nitrogen content of fuel, per cent mass
w_{EPS}	oxygen content of fuel, per cent mass

A.5.4.2. Calculation of the molar ratios of H, C, S, N and O related to C for the fuel mixture (according to ISO8178-1, Annex A-A.2.2.2).

$$\alpha = 11.9164 \times \frac{w_{ALF}}{w_{BET}} \quad (\text{A6.6})$$

$$\gamma = 0.37464 \times \frac{w_{GAM}}{w_{BET}} \quad (\text{A6.7})$$

$$\delta = 0.85752 \times \frac{w_{DEL}}{w_{BET}} \quad (\text{A6.8})$$

$$\varepsilon = 0.75072 \times \frac{w_{EPS}}{w_{BET}} \quad (\text{A6.9})$$

Where:

w_{ALF}	hydrogen content of fuel, per cent mass
w_{BET}	carbon content of fuel, per cent mass
w_{GAM}	sulphur content of fuel, per cent mass
w_{DEL}	nitrogen content of fuel, per cent mass
w_{EPS}	oxygen content of fuel, per cent mass
α	molar hydrogen ratio (H/C)
γ	molar sulphur ratio (S/C)
δ	molar nitrogen ratio (N/C)
ε	molar oxygen ratio (O/C)

referring to a fuel $\text{CH}_\alpha\text{O}_\varepsilon\text{N}_\delta\text{S}_\gamma$

A.5.4.3. Calculation of the u_{gas} values for a fuel mixture

The raw exhaust gas u_{gas} values for a fuel mixture can be calculated with the exact equations in paragraph 8.4.2.4. of Annex 4B and the molar ratios calculated according to this paragraph.

For systems with constant mass flow, equation 57 in paragraph 8.5.2.3.1. of Annex 4B is needed to calculate the diluted exhaust gas u_{gas} values.