

9 November 2015

Agreement

Concerning the Adoption of Uniform Technical Prescriptions for Wheeled Vehicles, Equipment and Parts which can be Fitted and/or be Used on Wheeled Vehicles and the Conditions for Reciprocal Recognition of Approvals Granted on the Basis of these Prescriptions*

(Revision 2, including the amendments which entered into force on 16 October 1995)

Addendum 36 – Regulation No. 37

Revision 7 - Amendment 7

Supplement 44 to the 03 series of amendments – Date of entry into force: 8 October 2015

Uniform provisions concerning the approval of filament lamps for use in approved lamp units of power-driven vehicles and of their trailers

This document is meant purely as documentation tool. The authentic and legal binding text is: ECE/TRANS/WP.29/2015/18.



UNITED NATIONS

* Former title of the Agreement: Agreement Concerning the Adoption of Uniform Conditions of Approval and Reciprocal Recognition of Approval for Motor Vehicle Equipment and Parts, done at Geneva on 20 March 1958.

Paragraph 3.5.4., amend to read:

"3.5.4. The length of a line filament shall be determined by its ends, defined — unless otherwise specified on the relevant data sheet — as the apices of the first and the last filament turn as seen in projection perpendicular to the reference axis of the filament lamp. Such an apex shall comply with the requirement that the angle formed by the legs shall not exceed 90°. In the case of coiled-coil filaments the apices of the secondary turns shall be taken into account. Apices outside the point of connection to the current lead-in legs shall be disregarded for the determination of the filament length."

Annex I,

List of categories of filament lamps, grouped and their sheet numbers, amend to read:

"

Group 1		
Without general restrictions:		
Category		Sheet number(s)
...		
H17		H17/1 to 6
H18		H18/1 to 4
H19		H19/1 to 5
H20		H20/1 to 4
H21W	*2	H21W/1 to 2

..."

List of sheets for filament lamps and their sequence in this annex, amend to read:

"

Sheet number(s)
....
H17/1 to 6
H18/1 to 4
H19/1 to 5
H20/1 to 4
H6W/1

..."

Sheet H1/1, note ², amend to read:

² Both current lead-in legs shall be positioned in the bulb, the longer leg above the filament (the filament lamp being viewed as shown in the figure). The internal design should be then such that stray light images and reflections are reduced to the minimum, e.g. by fitting cooling jackets over the non-coiled parts of the filament."

Sheet H7/3, the table, amend to read:

" ...

Cap PX26d in accordance with IEC Publication 60061 (sheet 7004-5-7)

..."

Sheet H17/2, the table, amend to read:

" ...

Cap PU43t-4 in accordance with IEC Publication 60061 (sheet 7004-171-2)

..."

After sheet H17/6, add new sheets H18/1 to H18/4, H19/1 to H19/5 and H20/1 to H20/4, to read (see following pages; one page per sheet):

The drawings are intended only to illustrate the essential dimensions (in mm) of the filament lamp

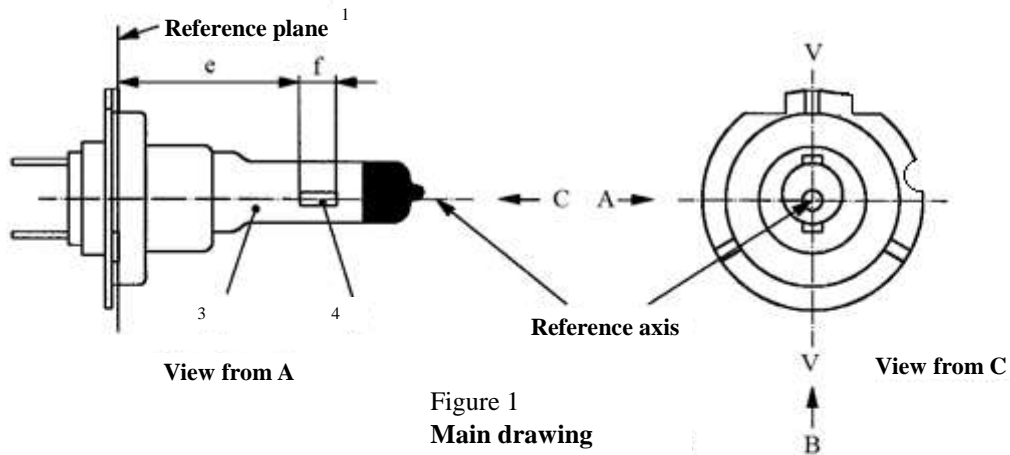

Figure 1
Main drawing

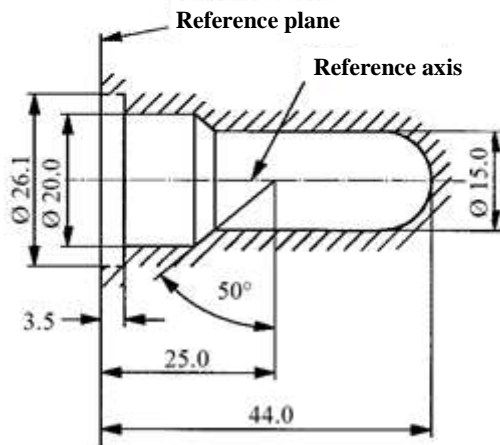

Figure 2
Maximum lamp outline⁵

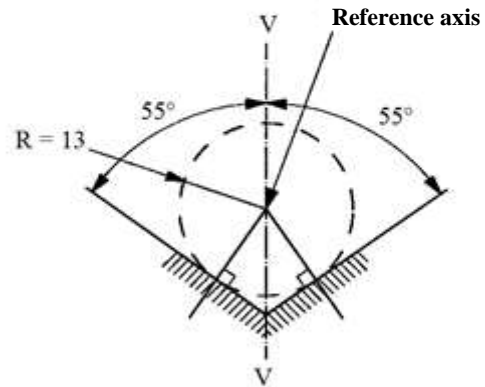

Figure 3
Definition of reference axis²

¹ The reference plane is defined by the points on the surfaces of the holder on which the three supporting bosses of the cap ring will rest.

² The reference axis is perpendicular to the reference plane and crosses the intersection of the two perpendiculars as indicated in Figure 3.

³ The colour of the light emitted shall be white or selective-yellow.

⁴ Notes concerning the filament diameter.

(a) No actual diameter restrictions apply but the design target is $d_{max} = 1.3$ mm.

(b) For the same manufacturer, the design diameter of standard (étalon) filament lamp and filament lamp of normal production shall be the same.

⁵ Glass bulb and supports shall not exceed the envelope as indicated in Figure 2. The envelope is concentric to the reference axis.

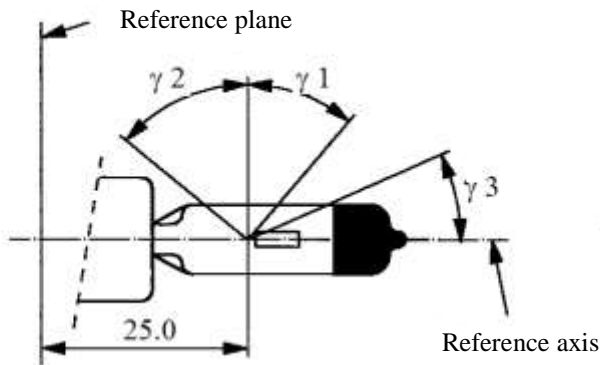

View from B

Figure 4
Distortion free area and black top^{6,7}

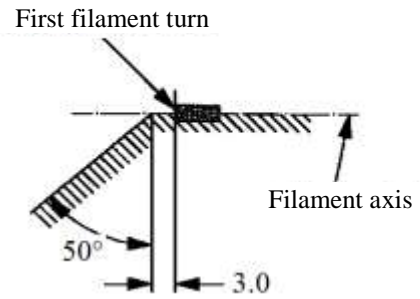

View from A

Figure 5
Metal free zone⁸

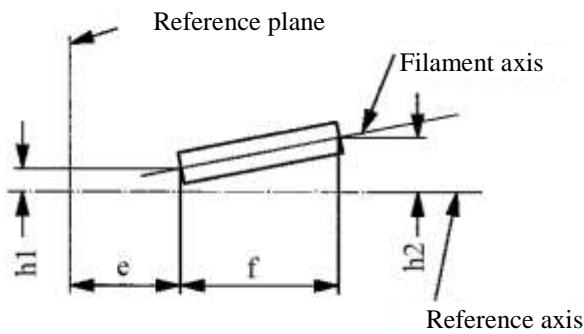

Figure 6
**Permissible offset of filament axis
 (for standard filament lamps only)**

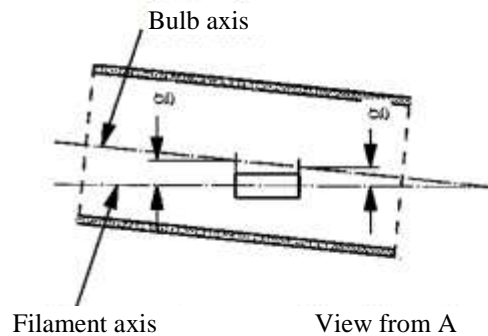

Figure 7
Bulb eccentricity

⁶ Glass bulb shall be optically distortion free within the angles γ_1 and γ_2 . This requirement applies to the whole bulb circumference within the angles γ_1 and γ_2 .

⁷ The obscuration shall extend at least to the cylindrical part of the bulb on the whole bulb top circumference. It shall moreover extend at least to a plane parallel to the reference plane where γ_3 crosses the outer bulb surface (view B as indicated on sheet H18/1).

⁸ The internal design of the lamp shall be such that stray light images and reflections are only located above the filament itself seen from the horizontal direction. (View A as indicated in Figure 1 on sheet H18 /1).

No metal parts other than filament turns shall be located in the shaded area as seen in Figure 5.

		<i>Filaments lamps of normal production</i>	<i>Standard filament lamp</i>
		<i>12 V</i>	<i>12 V</i>
e ⁹		25.0 ¹⁰	25.0 ± 0.1
f ⁹		4.8 ¹⁰	4.8 ± 0.1
g ¹²		0.5 min.	u.c.
h1 ¹¹		0 ¹⁰	0 ± 0.10
h2 ¹¹		0 ¹⁰	0 ± 0.15
γ1		40° min.	40° min.
γ2		50° min.	50° min.
γ3		30° min.	30° min.
Cap PY26d-1 in accordance with IEC Publication 60061 (sheet 7004-5-7)			
Electrical and photometric characteristics			
Rated values	Volts	12	12
	Watts	65	65
Test voltage	Volts	13.2	13.2
Objective values	Watts	69 max.	69 max.
	Luminous flux	1 700 ± 8 %	
Reference luminous flux at approximately		13.2 V	1 700

⁹ The ends of the filament are defined as the points where, when the viewing direction is direction A as shown in Figure 1 on sheet H18/1, the projection of the outside of the end turns crosses the filament axis.

¹⁰ To be checked by means of a "Box System", sheet H18/4.

¹¹ The offset of the filament with respect to the reference axis is measured only in viewing directions A and B as shown in Figure 1 in sheet H18/1. The points to be measured are those where the projection of the outside of the end turns nearest to or furthest from the reference plane crosses the filament axis.

¹² Offset of filament in relation to bulb axis measured in two planes parallel to the reference plane where the projection of the outside of the end turns nearest to or furthest from the reference plane crosses the filament axis.

Screen projection requirements

This test is used to determine, by checking whether the filament is correctly positioned relative to the reference axis and reference plane, whether a filament lamp complies with the requirements.

Dimensions in mm

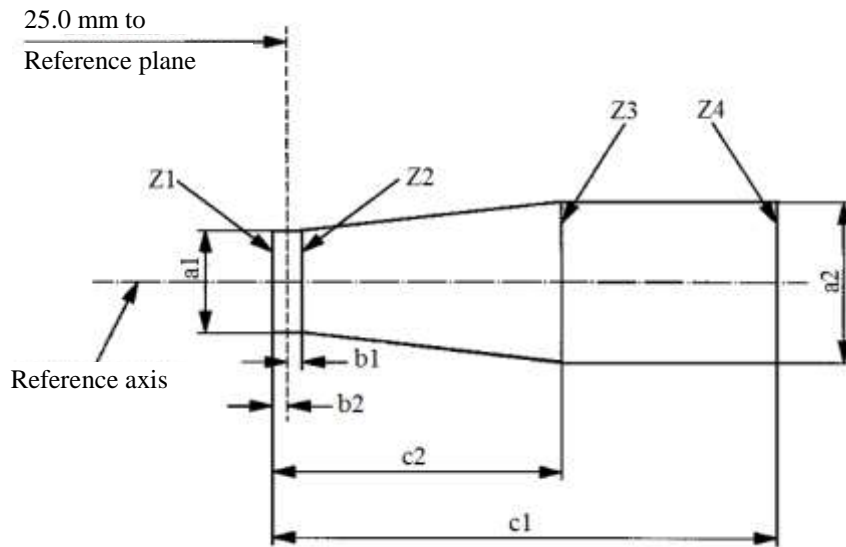

	$a1$	$a2$	$b1$	$b2$	$c1$	$c2$
12 V	$d + 0.30$	$d + 0.50$		0.2	5.3	4.7

d = diameter of filament

The filament position is checked solely in directions A and B as shown on sheet H18/1, Figure 1.

The filament shall lie entirely within the limits shown.

The ends of the filament as defined on sheet H18/3, note 9, shall lie between lines Z1 and Z2 and between Z3 and Z4.

The drawings are intended only to illustrate the essential dimensions (in mm) of the filament lamp.

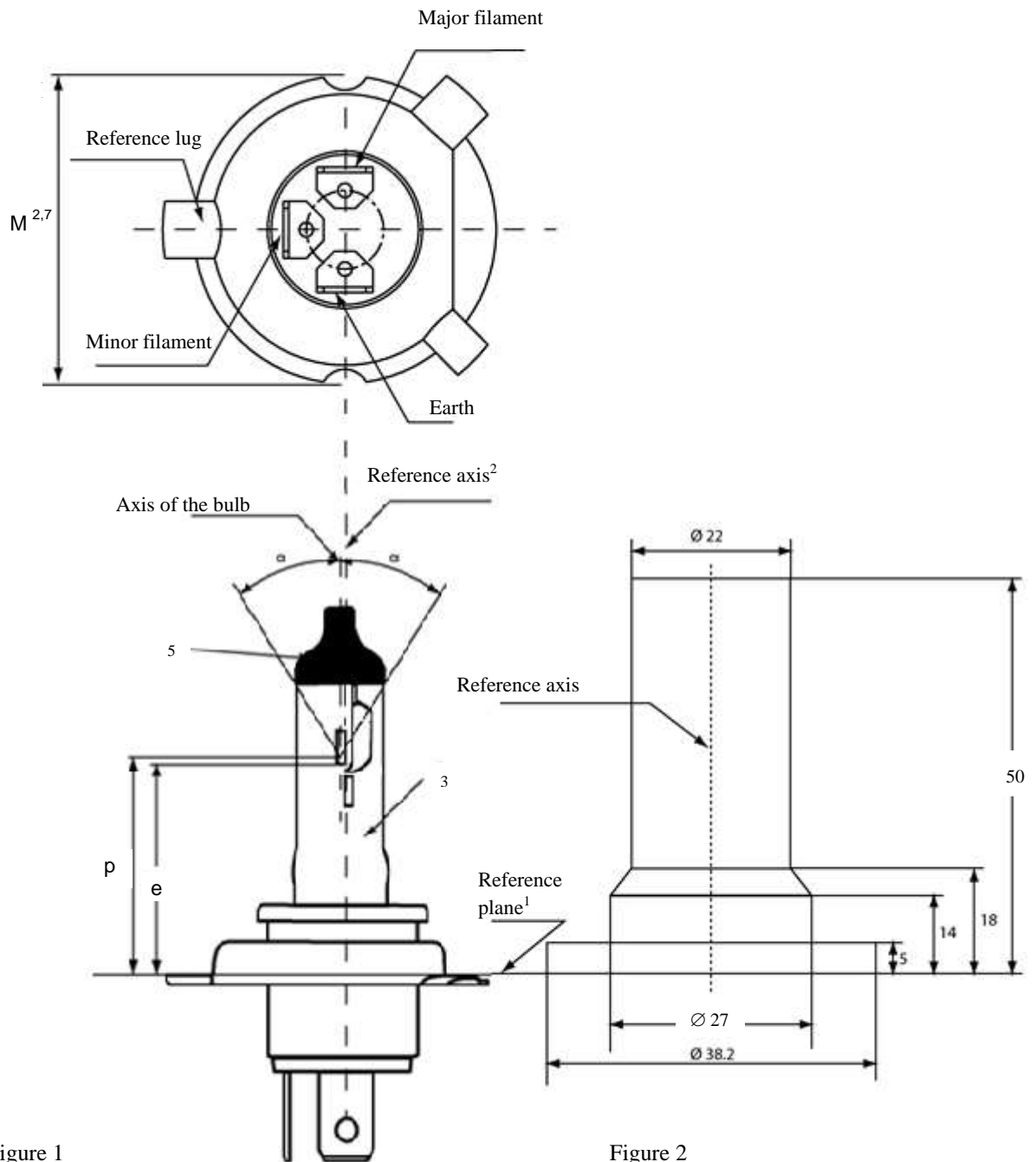

Figure 1
Main drawing

Figure 2
Maximum lamp outlines⁴

Category H19

Sheet H19/2

<i>Dimensions in mm</i>		<i>Filament lamps of normal production</i>		<i>Standard filament lamp</i>	
		<i>12 V</i>		<i>12 V</i>	
e		28.5 + 0.35 / - 0.15		28.5 + 0.20 / - 0.0	
p		28.95		28.95	
α		max. 45°		max. 45°	
Cap PU43t-3 in accordance with IEC Publication 60061 (sheet 7004-171-1)					
Electrical and photometric characteristics					
Rated values	Volts	12 ⁶		12 ⁶	
	Watts	60	55	60	55
Test values	Volts	13.2	13.2	13.2	13.2
Objective values	Watts	72 max.	68 max.	72 max.	68 max.
	Luminous flux	1 750 ± 10%	1 200 ± 10%		
Reference luminous flux at approximately			13.2 V	1 750	1 200

For note 6 see sheet H19/5.

Position of shield

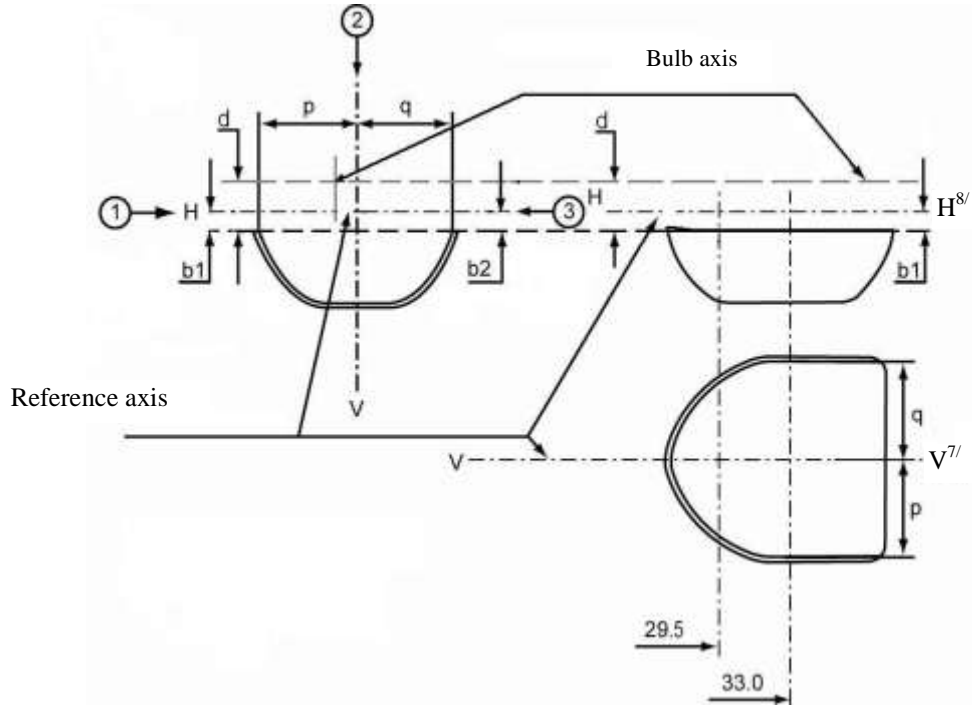

Position of filament

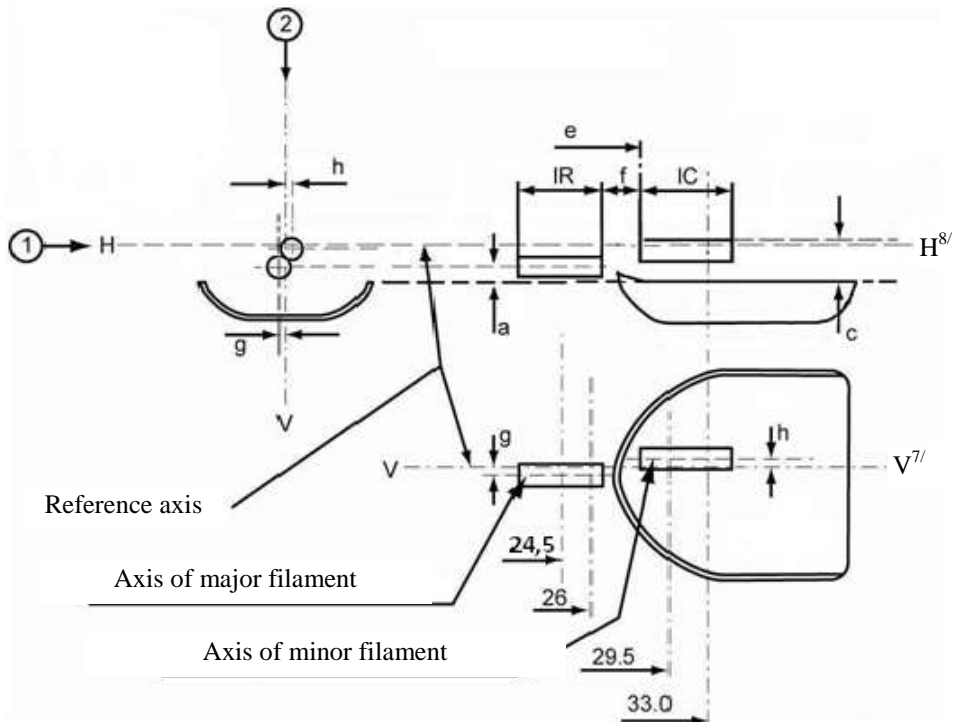

Category H19

Sheet H19/4

Table of the dimensions (in mm) referred to in the drawings on sheet H19/3

Reference*	Dimension**	Tolerance	
		Filament lamps of normal production	Standard filament lamp
a/26.0	0.7	±0.30	±0.20
a/24.5	0.7	±0.40	±0.20
b1/29.5	1.0	±0.30	±0.25
b1/33.0	b1/29.5 mv	±0.30	±0.15
b2/29.5	1.0	±0.30	±0.25
b2/33.0	b2/29.5 mv	±0.30	±0.15
c/29.5	1.7	±0.25	±0.15
c/33	c/29.5 mv	±0.25	±0.15
d	min. 1.1	-	-
e ¹¹	28.5	+0.35 / -0.15	+0.20 / -0.0
f ^{9, 10, 11}	1.4	±0.30	±0.15
g/26.0	0	±0.40	±0.30
g/24.5	0	±0.50	±0.25
h/29.5	0	±0.40	±0.25
h/33.0	h/29.5 mv	±0.30	±0.15
IR ^{9, 12}	4.0	±0.60	±0.30
IC ^{9, 10}	5.2	±0.60	±0.30
p/33.0	Depends on the shape of the shield	-	-
q/33.0	(p+q)/2	±0.60	±0.30

* ".../24.5" means dimension to be measured at the distance from the reference plane indicated in mm after the stroke.

** ".../29.5 mv" means the value measured at a distance of 29.5 mm from the reference plane.

For the notes see sheet H19/5.

- 1 The reference plane is the plane formed by the seating points of the three lugs of the cap ring.
- 2 The reference axis is perpendicular to the reference plane and passes through the centre of the circle of diameter "M".
- 3 The light emitted from standard filament lamps and from normal production lamps shall be white.
- 4 The bulb and supports shall not exceed the envelope as in Figure 2.
- 5 The obscuration shall extend at least as far as the cylindrical part of the bulb. It shall also overlap the internal shield when the latter is viewed in a direction perpendicular to the reference axis.
- 6 The value indicated in the left hand column relate to the major filament. Those indicated in the right-hand column relate to the minor filament.
- 7 Plane V-V is the plane perpendicular to the reference plane and passing through the reference axis and through the intersection of the circle of diameter "M" with the axis of the reference lug.
- 8 Plane H-H is the plane perpendicular to both the reference plane and plane V-V and passing through the reference axis.
- 9 The end turns of the filament are defined as being the first luminous turn and the last luminous turn that are at substantially the correct helix angle.
- 10 For the minor filament, the points to be measured are the intersections, seen in direction 1, of either the lateral edge of the shield or the filament axis with the outside of the end turns defined under note 9.
- 11 "e" denotes the distance from the reference plane to the beginning of the minor filament as defined above.
- 12 For the major filament the points to be measured are the intersections, seen in direction 1, of a plane, parallel to plane H-H and situated at a distance of 0.3 mm below it, with the end turns defined under note 9.

Additional explanations to sheet H19/3

The dimensions below are measured in three directions:

- 1 For dimensions b1, a, c, d, e, f, IR and IC.
- 2 For dimensions g, h, p and q.
- 3 For dimension b2.

Dimensions p and q are measured in planes parallel to and 33.0 mm away from the reference plane.

Dimensions b1, b2 are measured in planes parallel to and 29.5 mm and 33.0 mm away from the reference plane.

Dimensions c and h are measured in planes parallel to and 29.5 mm and 33.0 mm away from the reference plane.

Dimensions a and g are measured in planes parallel to and 24.5 mm and 26.0 mm away from the reference plane.

Note: For the method of measurement, reference is made to Appendix E of IEC Publication 60809.

The drawings are intended only to illustrate the essential dimensions (in mm) of the filament lamp

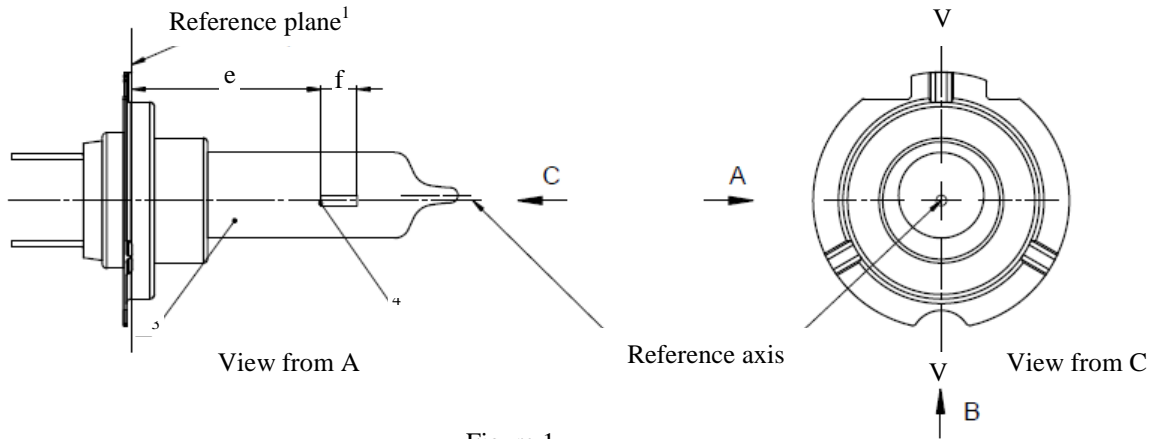

Figure 1
Main drawing

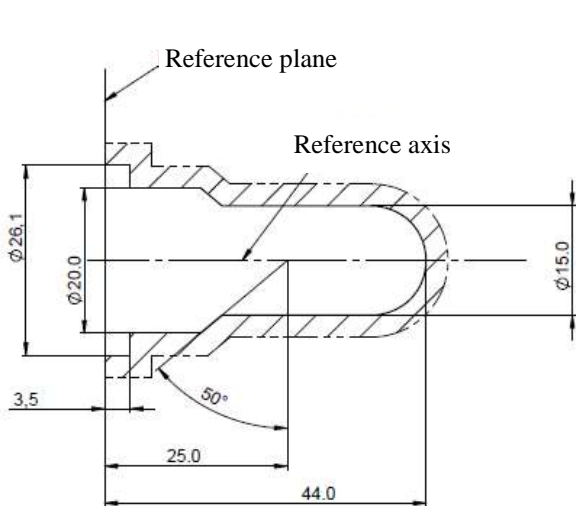

Figure 2
Maximum lamp outline⁵

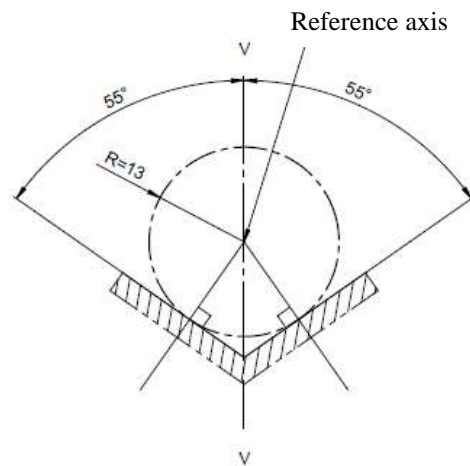

Figure 3
Definition of reference axis²

- ¹ The reference plane is defined by the points on the surfaces of the holder on which the three supporting bosses of the cap ring will rest.
- ² The reference axis is perpendicular to the reference plane and crosses the intersection of the two perpendiculars as indicated in Figure 3.
- ³ The colour of the light emitted shall be white with the restriction according to sheet H20/3.
- ⁴ Notes concerning the filament diameter:
 - (a) No actual diameter restrictions apply but the design target is to have $d_{max.} = 1.4$ mm.
 - (b) For the same manufacturer, the design diameter of standard (étalon) filament lamp and filament lamp of normal production shall be the same.
- ⁵ Glass bulb and supports shall not exceed the envelope as indicated in Figure 2. The envelope is concentric to the reference axis.

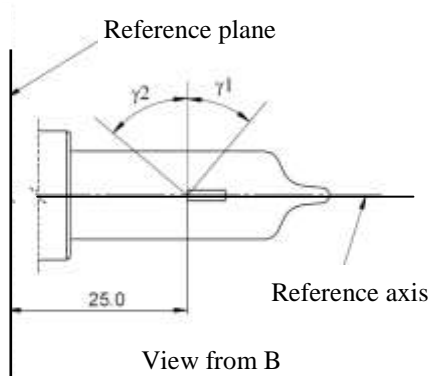

Figure 4
Distortion free area⁶

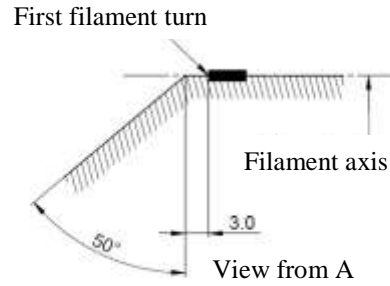

Figure 5
Metal free zone⁷

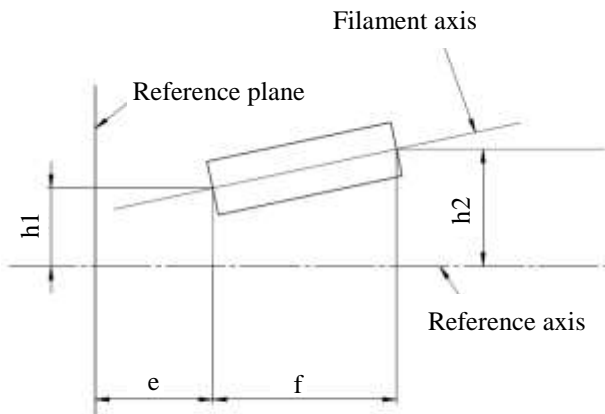

Figure 6
**Permissible offset of filament axis
 (for standard filament lamps only)**

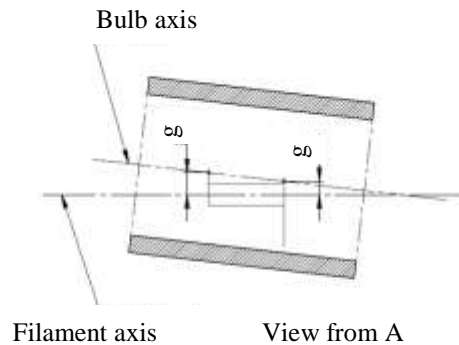

Figure 7
Bulb eccentricity

⁶ Glass bulb shall be optically distortion free within the angles γ_1 and γ_2 . This requirement applies to the whole bulb circumference within the angles γ_1 and γ_2 .

⁷ The internal design of the lamp shall be such that stray light images and reflections are only located above the filament itself seen from the horizontal direction. (View A as indicated in Figure 1 on sheet H20/1).

No metal parts other than filament turns shall be located in the shaded area as seen in Figure 5.

Category H20

Sheet H20/3

		<i>Filaments lamps of normal production</i>		<i>Standard filament lamp</i>	
		<i>Dimensions in mm</i>		<i>12 V</i>	<i>12 V</i>
e ⁸		25.0 ⁹		25.0 ± 0.1	
f ⁸		4.8 ⁹		4.8 ± 0.1	
g ¹¹		0.5 min.		0.5 min.	
h1 ¹⁰		0 ⁹		0 ± 0.10	
h2 ¹⁰		0 ⁹		0 ± 0.15	
γ1		40° min.		40° min.	
γ2		50° min.		50° min.	
Cap PY26d-6 in accordance with IEC Publication 60061 (sheet 7004-5-7)					
Electrical and photometric characteristics					
Rated values	Volts		12	12	
	Watts		70	70	
Test voltage	Volts		13.2	13.2	
Objective values	Watts		75 max.	75 max.	
	Luminous flux		1 250 ± 10 %		
Reference luminous flux at approximately			12 V	900	
			13.2 V	1250	
Chromaticity Coordinates ¹²	Objective		x=0.347	y=0.353	
	Tolerance area	Boundaries	x=0.330	y=0.150+0.640x	
			x=0.370	y=0.050+0.750x	
		Intersection points	x=0.330	y=0.298	
			x=0.370	y=0.327	
			x=0.370	y=0.387	
	x=0.330	y=0.361			

⁸ The ends of the filament are defined as the points where, when the viewing direction is direction A as shown in Figure 1 on sheet H20/1, the projection of the outside of the end turns crosses the filament axis. (Special instructions for coiled-coil filaments are under consideration).

⁹ To be checked by means of a "Box System", sheet H20/4.

¹⁰ The offset of the filament with respect to the reference axis is measured only in viewing directions A and B as shown in Figure 1 in sheet H20/1. The points to be measured are those where the projection of the outside of the end turns nearest to or furthest from the reference plane crosses the filament axis.

¹¹ Offset of filament in relation to bulb axis measured in two planes parallel to the reference plane where the projection of the outside of the end turns nearest to or furthest from the reference plane crosses the filament axis.

¹² See Annex 5.

Screen projection requirements

This test is used to determine, by checking whether the filament is correctly positioned relative to the reference axis and reference plane, whether a filament lamp complies with the requirements.

Dimensions in mm

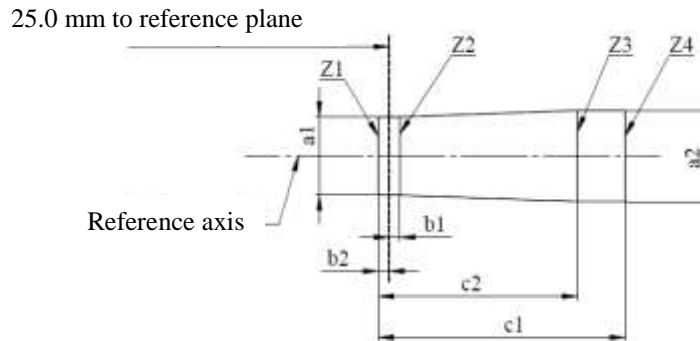

a_1	a_2	b_1	b_2	c_1	c_2
$d + 0.40$	$d + 0.70$	0.25		5.7	4.6

d = diameter of filament

The filament position is checked solely in directions A and B as shown on sheet H20/1, Figure 1.

The filament shall lie entirely within the limits shown.

The ends of the filament as defined on sheet H20/3, note 9, shall lie between lines Z1 and Z2 and between Z3 and Z4."

Sheet PC16W/2, the table, amend to read:

" ...

PC16W	Cap PU20d-1	
PCY16W	Cap PU20d-2	in accordance with IEC Publication 60061 (sheet 7004-158-1)
PCR16W	Cap PU20d-7	
PW16W	Cap WP3.3x14.5-8	
PWY16W	Cap WP3.3x14.5-9	in accordance with IEC Publication 60061 (sheet 7004-164-1)
PWR16W	Cap WP3.3x14.5-10	

..."

Sheet PR21/5W/1, the following drawing,

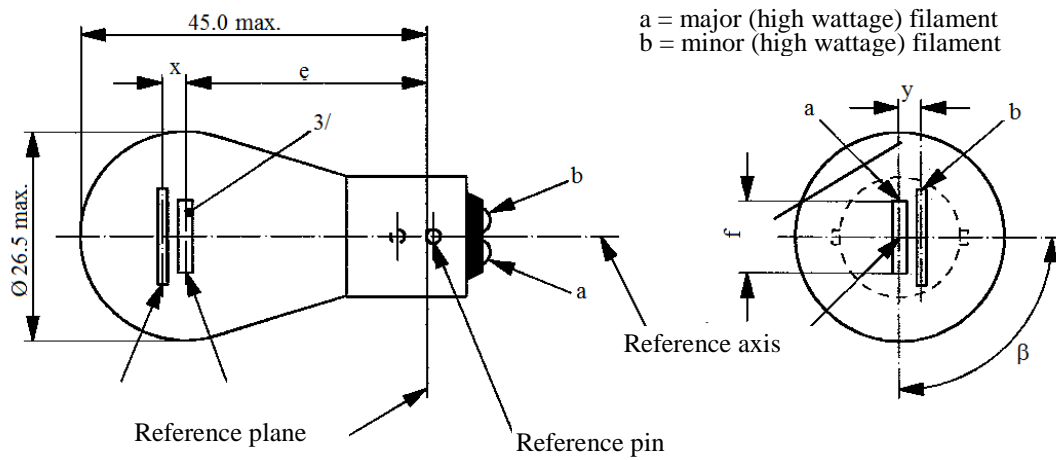

amend to read:

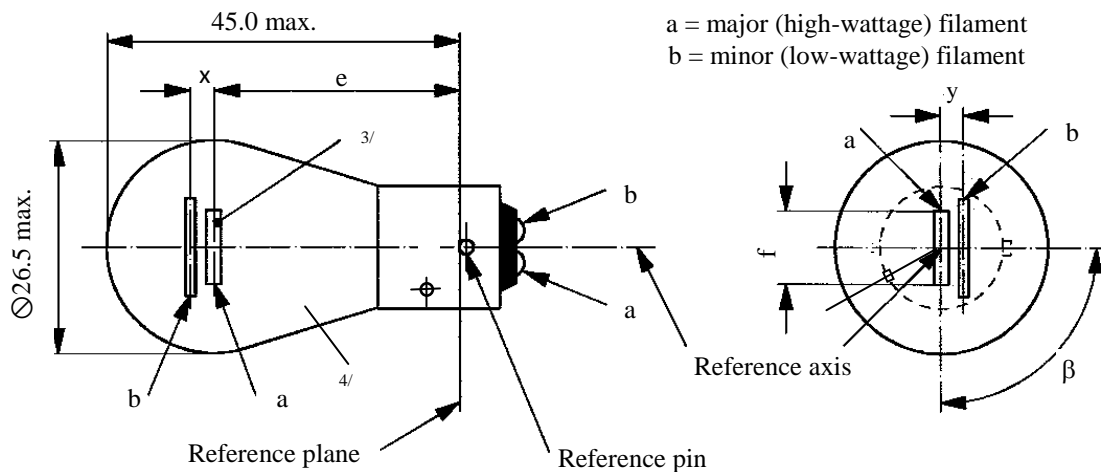

Sheet W15/5W/1, the table, amend to read:

" ...

Cap WZ3x16q in accordance with IEC Publication 60061 (sheet 7004-151-2)

 ..."

Sheet W21W/1, the table, amend to read:

" ...

Cap W3x16d in accordance with IEC Publication 60061 (sheet 7004-105-3)
--

 ..."

Sheet W21/5W/1, the table, amend to read:

" ...

Cap W3x16q in accordance with IEC Publication 60061 (sheet 7004-106-4)

Sheet WR21/5W/1, the table, amend to read:

" ...

Cap WY3x16q in accordance with IEC Publication 60061 (sheet 7004-106-4)

..."

Sheet WY21W/1, the table, amend to read:

" ...

Cap WX3x16d in accordance with IEC Publication 60061 (sheet 7004-105-3)

..."

Annex 5,

Insert a new paragraph 2.4., to read:

"2.4. Restricted colour boundaries.

The following figure shows the colour tolerance area for the colour white (within the dashed lines) and the restricted tolerance area for the filament light source H20 (shaded area within the solid lines) in the CIE chromaticity coordinate system (x, y).

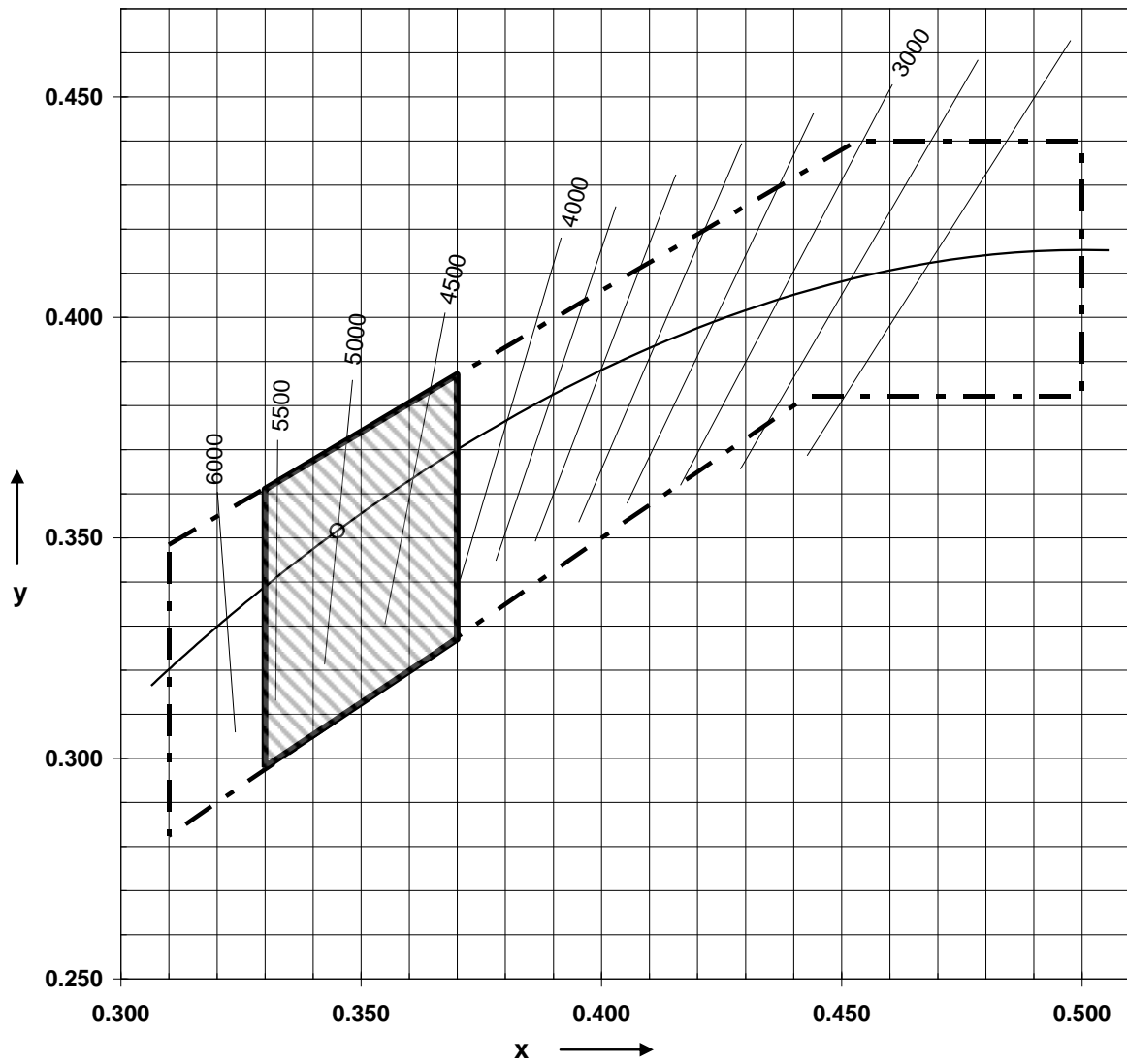

"