

18 February 2015

Original: English

English/Russian only

---

## Agreement

### **Concerning the Adoption of Uniform Technical Prescriptions for Wheeled Vehicles, Equipment and Parts which can be Fitted and/or be Used on Wheeled Vehicles and the Conditions for Reciprocal Recognition of Approvals Granted on the Basis of these Prescriptions\***

(Revision 2, including the amendments which entered into force on 16 October 1995)

---

#### **Addendum 13 – Regulation No. 14**

#### **Revision 5 - Corrigendum 1**

Corrigendum 1 to Revision 5 of the Regulation (*Erratum by the secretariat*)

#### **Uniform provisions concerning the approval of vehicles with regard to safety-belt anchorages, ISOFIX anchorages systems and ISOFIX top tether anchorages and i-Size seating positions**



UNITED NATIONS

---

\* Former title of the Agreement: Agreement Concerning the Adoption of Uniform Conditions of Approval and Reciprocal Recognition of Approval for Motor Vehicle Equipment and Parts, done at Geneva on 20 March 1958.

Annex 9,

Figure 2, correct to read:

" ...

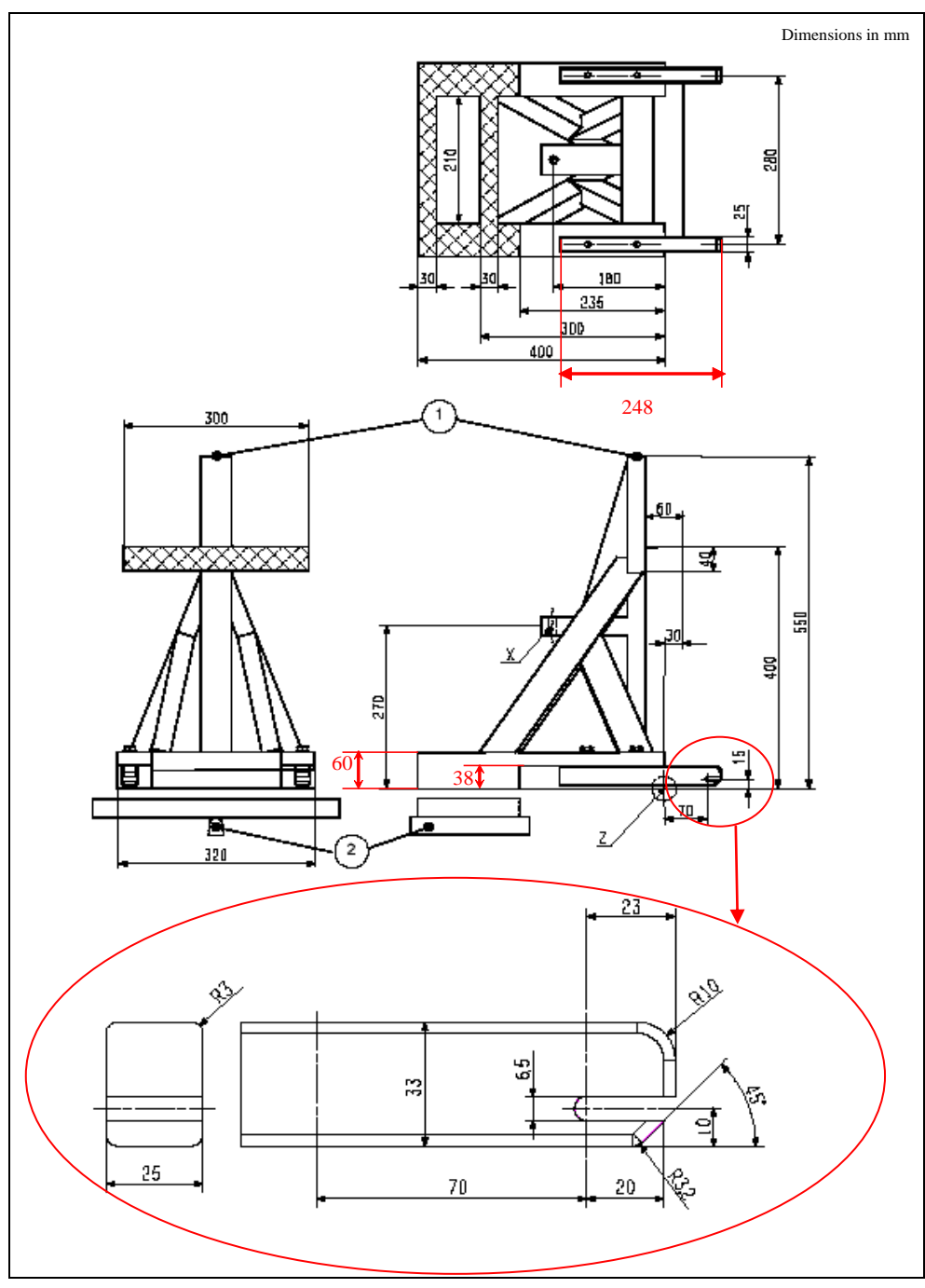

" ...